

# TSG61 HYDRAULIC STUMP GRINDER



## Operator's Manual

**MechMaxx**

[www.mechmaxx.com](http://www.mechmaxx.com)





---

## TABLE OF CONTENTS

---

<b>TABLE OF CONTENTS</b>	<b>1</b>	<b>MAINTENANCE</b>	<b>7</b>
<b>SPECIFICATIONS</b>	<b>2</b>	BEFORE EVERY USE	7
<b>SAFETY SIGNS</b>	<b>3</b>	EVERY WEEK	7
<b>SAFETY</b>	<b>4</b>	AFTER EVERY SEASON	7
YOUR SAFETY	4	CUTTING TEETH REMOVAL AND REPLACEMENT	7
GENERAL SAFETY	4	LUBRICATION	7
AVOID ROLLOVER	4	HYDRAULIC SYSTEM	8
PTO SHAFT	4	BOLT TORQUE	8
<b>OPERATION</b>	<b>5</b>	ENGLISH TORQUE SPECIFICATIONS	8
REQUIRED EQUIPMENT OF THE TRACTOR	5	METRIC TORQUE SPECIFICATIONS	9
PTO SHAFT ADJUSTMENT	5	<b>PARTS DIAGRAM</b>	<b>10</b>
TRACTOR MOUNTING	6	<b>PARTS LIST</b>	<b>11</b>
GRINDING OPERATION	6		

## SPECIFICATIONS

Model	TSG61
Power Required	35-60 HP
Hydraulic Flow Rate	5-13 GPM
Rotor Size	24 in
Carbide Steel Bolt-On Teeth	16 (Replaceable)
Required PTO Speed	540 RPM
Hydraulic Hose Length	6.6 ft
Hydraulic Fittings Size	G1/2 in
Cutting Height Above	18 in
Cutting Depth Below	12 in
Cutting Depth Per Pass	6 in
Swing Arc	40°
Cutting Direction	Horizontal and vertical
3-Point Hitch	Category 1 & 2
PTO Shaft	05B-LF-1600 With Slip Clutch 63-77 in
Dimensions (LxWxH)	69 x 34 x 32in
Finish	Powder Coat Paint Galvanized Steel
Warranty	1 year
Weight (N.W./G.W.)	684/750lbs

**SAFETY SIGNS**

The rating plate on your machine may show symbols. These represent important information about the product or instructions on its use.

**! WARNING !**

**To Prevent Serious Injury Or Death:**

- Read and understand Operator's manual before using.
- Do not permit riders on the tractor or mower. Never carry child on tractor seat.
- Operate with guards installed and in good condition.
- Operate only with tractor equipped with ROPS and seatbelts.
- Keep away from moving parts.
- Stop engine, set brake and wait for all moving parts to stop before dismounting.
- Be sure lights and reflectors required by law are clean and in good working order before transporting.
- Do not allow children to operate mower.
- Travel with SMV and lights that follow local codes.
- Clean debris from mowing area.
- Do not operate in the raised position.
- Support securely before working beneath unit.
- Review safety instructions annually.

**! DANGER**



**ROTATING DRIVELINE CONTACT CAN CAUSE DEATH KEEP AWAY! DO NOT OPERATE WITHOUT :**

- All driveline guards, tractor, and equipment shields in place.
- Drivelines securely attached at both ends.
- Driveline guards that turn freely on driveline.

**! WARNING**



**Read and understand operators manual before using this machine.**

**! DANGER !**



**ROTATING KNIVES HAZARD**

To prevent serious injury or death from rotating knives:

- DO NOT go under frame when rotor is turning or engine is running. Keep others away.
- Disconnect & lockout power source BEFORE adjusting or servicing.
- Keep hands, feet, hair, and clothing away from moving parts.

**! WARNING**

The PTO Driveline **MUST** be measured and cut (if required) as per the Owner's Manual. Failure to do so will result in damage to both the tractor and the implement.

**! DANGER**



**ROTATING BLADES KEEP HANDS AWAY**



## SAFETY

### YOUR SAFETY

YOU are responsible for the SAFE operation and maintenance of your MECHMAXX TSG61 Stump Grinder. YOU must ensure that you and anyone else who is going to use, maintain or work around the TSG61 Stump Grinder be familiar with the operating and maintenance procedures and related SAFETY information contained in this manual. This manual will take you step-by-step through your working day and alerts you to all good safety practices that should be used while followed the TSG61 Stump Grinder.

Remember, YOU are the key to safety. Good safety practices not only protect you but also the people around you. Make these practices a working part of your safety program. Be certain that EVERYONE using this equipment is familiar with the recommended using and maintenance procedures and follows all the safety precautions. Most accidents can be prevented. Do not risk injury or death by ignoring good safety practices.

In order to prevent accidents carefully read and observe the following instructions:



### GENERAL SAFETY

Prevent serious injury or death.

Read and understand this manual before operating stump grinder.

Always stop engine and remove key before leaving operator's seat.

Never allow anyone near the stump grinder during operation.

Prevent serious injury or death from moving parts.

Moving parts can crush and dismember. Do not operate without guards and shields in place.

Disconnect and lockout power source before adjusting or performing maintenance.

Use stump grinder only for the designed applications.

Any other use may result in personal injury, damage to equipment and may void the warranty.

Verify stump grinder is locked to quick attach hitch before operation or transport.

### AVOID ROLLOVER

The equipment may rollover, resulting in death or serious injury. To help prevent rollover:

Travel at a slow speed.

Avoid sharp turns & sudden movement on slopes.

Carry stump grinder close to the ground.

Avoid holes, ditches and other obstructions which may cause equipment to rollover.

Use caution when operating on slopes and do not operate on excessively steep slopes.

Do not exceed load capacity of equipment.

### PTO SHAFT

1. Only use PTO shafts recommended by the manufacturer by the manufacturer.
2. The PTO shaft shielding (including guards and cones) must be mounted on the machine and be in perfect condition.
3. Observe the recommended shielding position in transport and working position.
4. The cardan shaft can only be connected or disconnected, when the tractor PTO is disengaged, the engine has stopped and the ignition key has been removed.
5. The cardan shaft must always be properly mounted and protected.
6. When disconnected, secure the PTO shaft to its holder using the provided chain (or other means) to prevent rotation or dragging.
7. Before engaging the tractor PTO make sure that the chosen speed and direction of rotation match the speed and rotation direction specified in the Specifications section.
8. Before engaging the PTO make sure no person is standing in the danger area of the machine. This rule must also be observed during machine operation.
9. Put the disconnected cardan shaft on the intended holder.

## OPERATION



**Must add oil before first use.**

THE GEARBOX AND TRANSMISSION ARE SHIPPED WITHOUT OIL.

ADD OIL BEFORE FIRST USE!

Gear Oil SAE90 2200ml (approx. 2.3 US Quarts)

Check oil level in gearbox by removing the plug located on the right-hand side. Oil should be level with bottom of plug hole. Add oil if necessary, by removing top fill plug and side plug. Add oil until it flows from side plug hole.

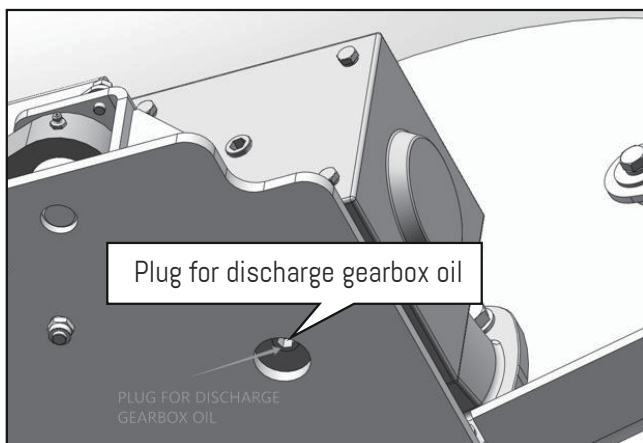
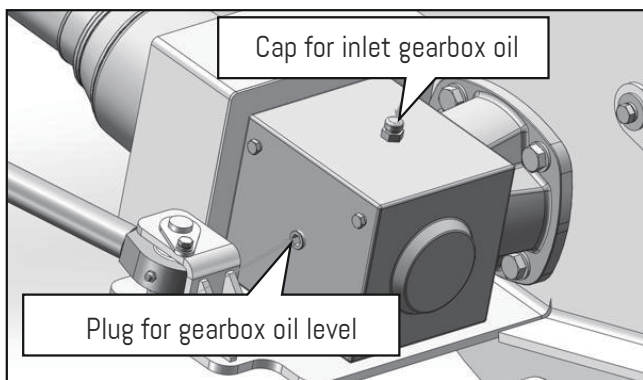

Do not overfill!

IMPORTANT: Implements should be level when checking oil in gearbox!

### REQUIRED EQUIPMENT OF THE TRACTOR

PTO shaft with chosen gear ratio, max. 540 RPM.

Three-point hitch of I category.

The model MECHMAXX TSG61 requires a tractor of at least 20 hp or up to a maximum of 60 hp.

Maximum number of revolutions and direction of tractor PTO shaft rotation is 540 rpm/min.

### PTO SHAFT ADJUSTMENT

Length of PTO shaft needs to be adjusted for different tractors (figure F1-F4).

Ascertain the accurate length in the following manner:

1. Shut down the tractor.
2. Connect the machine to the tractor.
3. Extract the PTO shaft apart and connect the individual shaft halves to the tractor and machine and compare them crosswise and mark them (figure F1).
4. Shorten external and internal plastic shield tubes (figure F2).
5. Shorten external and internal slide profiles by the same amount as plastic shield tubes (figure F3).
6. Deburr the cut ends of both the inner and outer profiles, remove any filings, and thoroughly grease the sliding surfaces (figure F4).

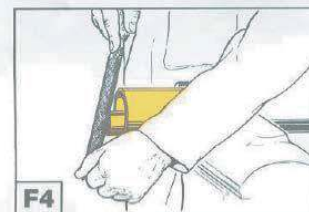
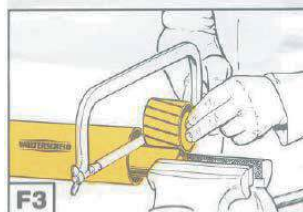
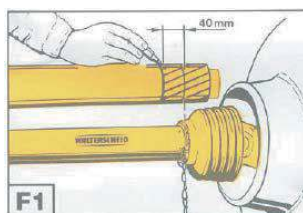

## TRACTOR MOUNTING

When connecting the winch, do not stand in the danger zone!

The forestry winch can be attached to every tractor with a three-point hitch with a category I coupling. Appropriate construction also enables easy connection to the tractor with automatic connection rods. Connect the prescribed PTO shaft and secure cardan protection with a hang chain.

Be careful that the cardan clicks into place on both connection points!

Once the winch is attached to the tractor, strengthen the stabilizers on the lower connection rods and level the winch with a hitch nut into position, so that the winch is tilted backwards for approximately 20 degrees.

## GRINDER

The cutting height should be 0.5"-1.25". we think the customer cutting more than 1.25", that makes grinder working slowly.

The grinder should work from right to left or left to right. grinder parallel not vertical.

When the attachment has completed a pass, move it rearward about 0.5"-1.25" and engage the control to cut back across in the opposite direction. Never directly up to down.

Operate the cutting wheel at 540 rpm (speed while under no load).

The cutting wheel feed is controlled by the hydraulic cylinder and the pressure control valve.

The rate of cut will depend on the type of tree, condition of the wood, and the condition of the carbide cutting teeth.

Excessive feed rates will either stall the engine or slip the clutch.

Too light a feed will produce sawdust.

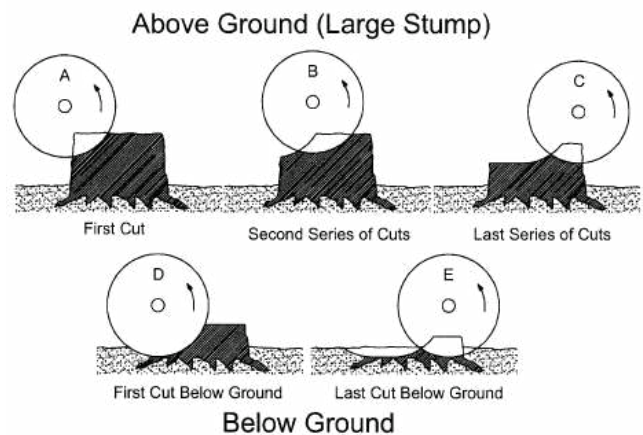

Please adjust the two speed flow valves in the cylinders by a suitable level depend on your tractor, ensure swing cylinder make the arm by smooth/ and slow moving from right to left. NEVER use high speed in cylinder /arm swing moving.

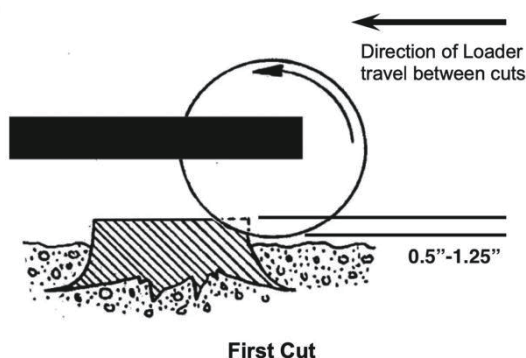
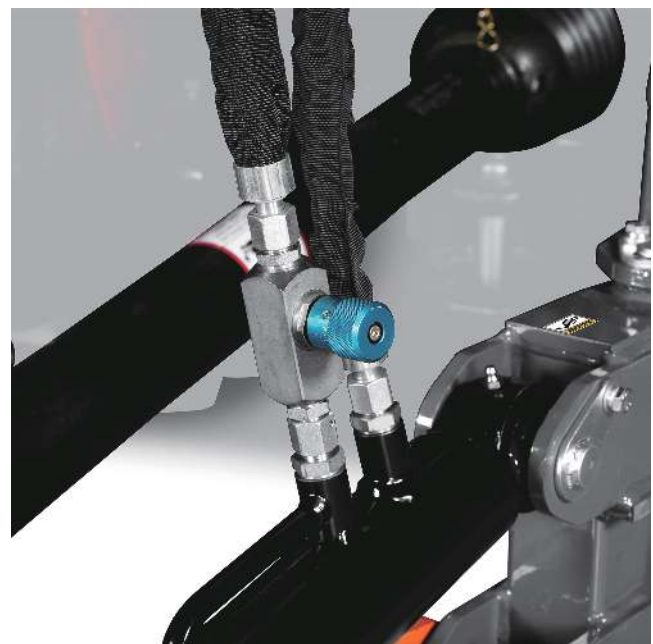

## MAINTENANCE

### BEFORE EVERY USE

Check hydraulic hoses and fittings daily for leaks. Replace hose if worn or damaged. Investigate the location of any oil leaks and repair. Lubricate all joints with lithium grease.

Inspect the unit for any buildup of contamination (dirt, stones, etc.).

Check cutting teeth every 2 hours of use. Keep cutting teeth in good condition. Unit will cut faster and remaining teeth will last longer if broken teeth are replaced.

Check that all fasteners (nuts, bolts, pins, keepers) are in their right place and are tight. Inspect and replace any worn, torn, or missing safety decals.

### EVERY WEEK

Check the condition of the teeth base and/or teeth. Order parts if the cutting edge or points are becoming worn and replace as soon as possible.

### AFTER EVERY SEASON

Inspect the implement for any loose or worn parts that may need to be replaced prior to the next season.

Visually inspect the teeth. Replace, if necessary.

Clean, sand & repaint any area that looks worn or scratched to prevent further rusting. Use an equipment-paint found at your local hardware store or building center.

Replace any warning decals that have been lost or damaged.

Store your implement in a shed or cover with a water-proof tarp to protect it from the weather. Store in an area not frequented by children.

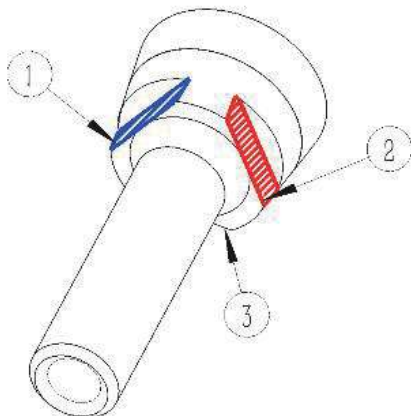

### CUTTING TEETH REMOVAL & REPLACEMENT

1. Support stump grinder to prevent falling.
2. Stop skid steer engine and remove key.
3. Inspect cutting teeth for damage. Rotated the tooth 3 times before replace it.
4. Replace individual teeth as needed.
5. Remove lock nut (1) and cutting tooth (2)
6. Rotated the tooth or install replacement tooth and lock nut. Tighten locknut (1) to 95 lb./ft. (129 Nm) of torque. Do not allow untrained or unqualified people to operate this equipment.

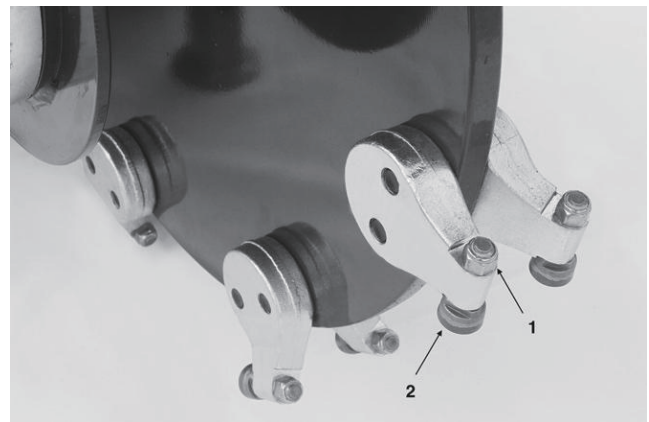

### LUBRICATION

Gearbox



Type of Lubrication: SAE 90W Gear Lube

Check oil level in gearbox by removing the plug located on the right hand side. Oil should be level with bottom of plug hole. Add oil if necessary by removing top fill plug and side plug. Add oil until it flows from side plug hole. Do not overfill!

**IMPORTANT:** Implements should be level when checking oil in gearbox!

**To avoid an accident that could result in Death or Serious Injury, never find yourself in a position where any body part is located under an unsupported blade or frame when servicing this attachment.**

**Hazardous dust can be generated if painted surfaces are heated or welded and could result in death or Serious Injury. Remove paint before welding and always make repairs in a well-ventilated area and wear an approved respirator.**

Cutting edges can be very heavy and could cause Minor or Serious Injury if mishandled. Always wear protective gloves and footwear.

1. Weld-on cutting edge replacement is not a task for most machinery operators and should be referred to a welding shop that possesses the proper equipment, knowledge, and experience.
2. Replacement cutting edges are available from your dealer.

### HYDRAULIC SYSTEM

**A small stream of oil from a pinhole leak could penetrate your skin if contacted. To avoid an accident that could result in Death or Serious Injury, never use your hand or other body parts in an attempt to locate a hydraulic leak.**

**Always release the hydraulic system pressure from the hydraulic circuits prior to removing the attachment or any hydraulic system service work.**

### BOLT TORQUE

#### CHECKING BOLT TORQUE

The tables shown below give correct torque values for various bolts and cap screws. Tighten all bolts to the torques specified in chart unless otherwise noted. Check tightness of bolts periodically, using bolt torque chart as a guide. Replace hardware with the same strength bolt.

Torque figures indicated above are valid for non-greased or non-oiled threads and heads unless otherwise specified. Therefore, do not grease or oil bolts or cap screws unless otherwise specified in this manual. When using locking elements, increase torque values by 5%.

\* Torque value for bolts and cap screws is identified by their head markings

### ENGLISH TORQUE SPECIFICATIONS

Bolt Diameter "A"	Bolt Torque					
	SAE 2		SAE 5		SAE 8	
	N.m	lb-ft	N.m	lb-ft	N.m	lb-ft
1/4"	8	6	12	9	17	12
5/16"	13	10	25	19	36	27
3/8"	27	20	45	33	63	45
7/16"	41	30	72	53	100	75
1/2"	61	45	110	80	155	115
9/16"	95	60	155	115	200	165
5/8"	128	95	215	160	305	220
3/4"	225	165	390	290	540	400
7/8"	230	170	570	420	880	650
1"	345	225	850	630	1320	970

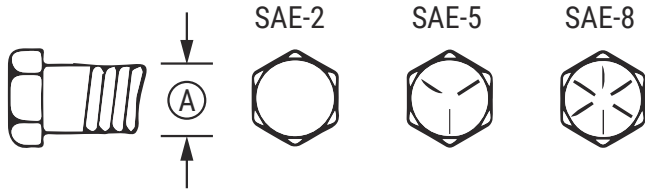

**METRIC TORQUE SPECIFICATIONS**

Bolt Diameter "A"	Bolt Torque			
	8.8		10.9	
	N.m	lb-ft	N.m	lb-ft
M3	0.5	0.4	1.8	1.3
M4	3	2.2	4.5	3.3
M5	6	4	9	7
M6	10	7	15	11
M8	25	18	35	26
M10	50	37	70	52
M12	90	66	125	92
M14	140	103	200	148
M16	225	166	310	229
M20	435	321	610	450
M24	750	553	1050	744
M30	1495	1103	2100	1550
M36	2600	1917	3675	2710

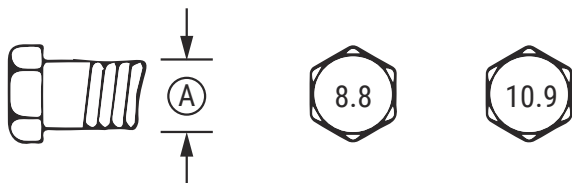

**LUBRICATION**

TSG61 grease fitting: Lubricate approximately once every 10 to 30 days.

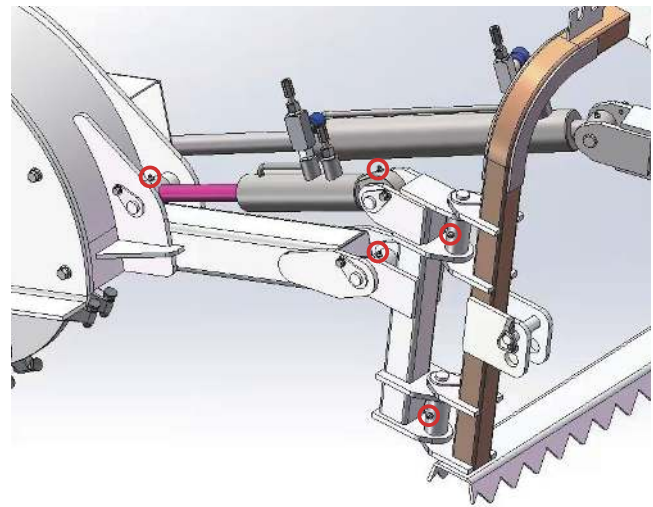

## PARTS DIAGRAM

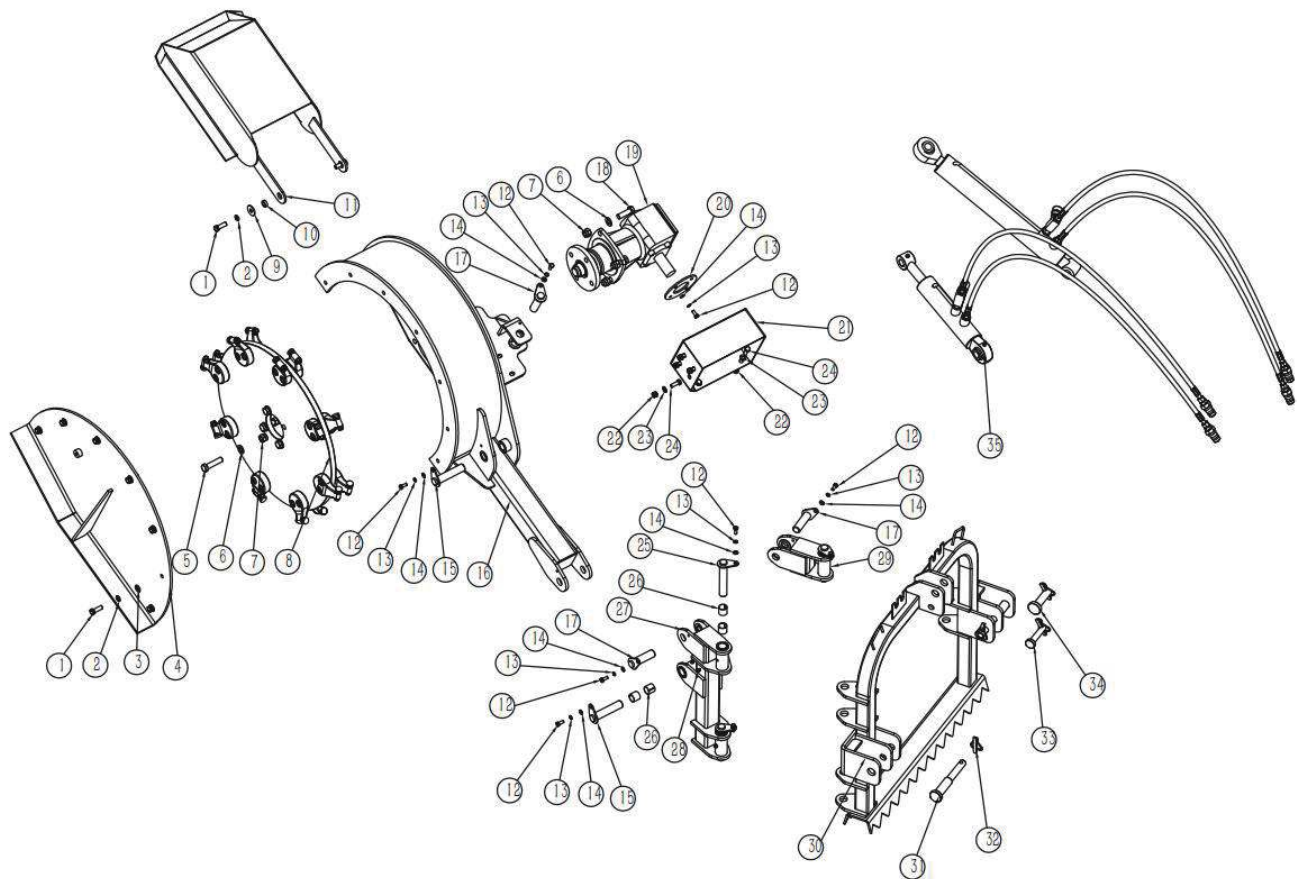

## PARTS LIST

REF	DESCRIPTION	QTY
1	Bolt M12X35	9
2	Spring Washer 12	9
3	Washer 12	7
4	Outer Plate Weldment	1
5	Bolt M16*65	4
6	Washer 16	8
7	Lock Nut M16	8
8	Cutting Wheel Assembly	1
9	Big Washer 12	2
10	Guard Spacer	2
11	Guard Weldment	1
12	Bolt M8X20	12
13	Spring Washer 8	12
14	Washer 8	12
15	Cylinder Pin 1	2
16	Frame Weldment	1
17	Cylinder Pin 2	3
18	Bolt M16X50	4
19	Gearbox Assembly	1
20	Gearbox Protection Plate	1
21	Gearbox Protection Cover	1
22	Lock Nut M10	8
23	Washer 10	8
24	Bolt M10X30	8
25	Rotary Linkage Weldment	3
26	Bearing 28X25X25	8
27	Rotary Weldment	1
28	Grease Nipple M8	4
29	Rotary Weldment 2	1

REF	DESCRIPTION	QTY
30	Supporting Weldment	1
31	Lower Pin	2
32	Lock Pin 10*45	4
33	Upper Pin 01	1
34	Upper Pin 02	1
35	Hydraulic Components	1

**PARTS DIAGRAM**

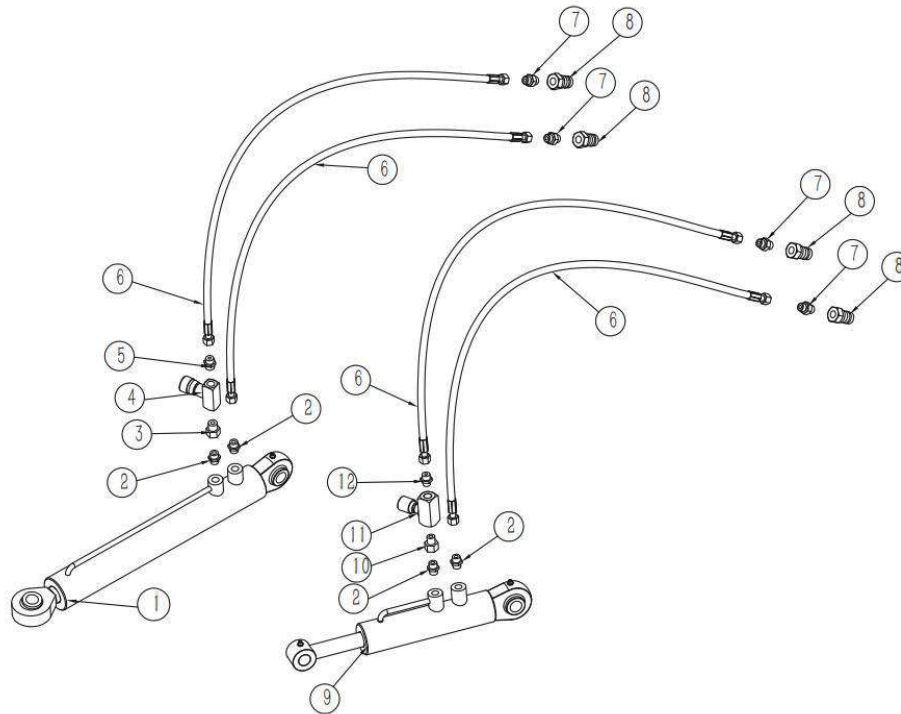

**PARTS LIST**

REF	DESCRIPTION	QTY
1	Swing Cylinder	1
2	End Straight Joint M16x1.5-M16x1.5	4
3	End Straight Joint M16x1.5-G3/8	1
4	Control Valve	1
5	End Straight Jointm16x1.5-G3/8	1
6	Oil Hose	4
7	End Straight Joint M16*1.5-G1/2"	4
8	Quick Change Connector G1/2	4
9	Lifting Cylinder	1
10	End Straight Joint M16x1.5-G1/4	1
11	One-Way Flow Control Valve	1
12	End Straight Joint M16x1.5-G1/4	1



**PARTS DIAGRAM**

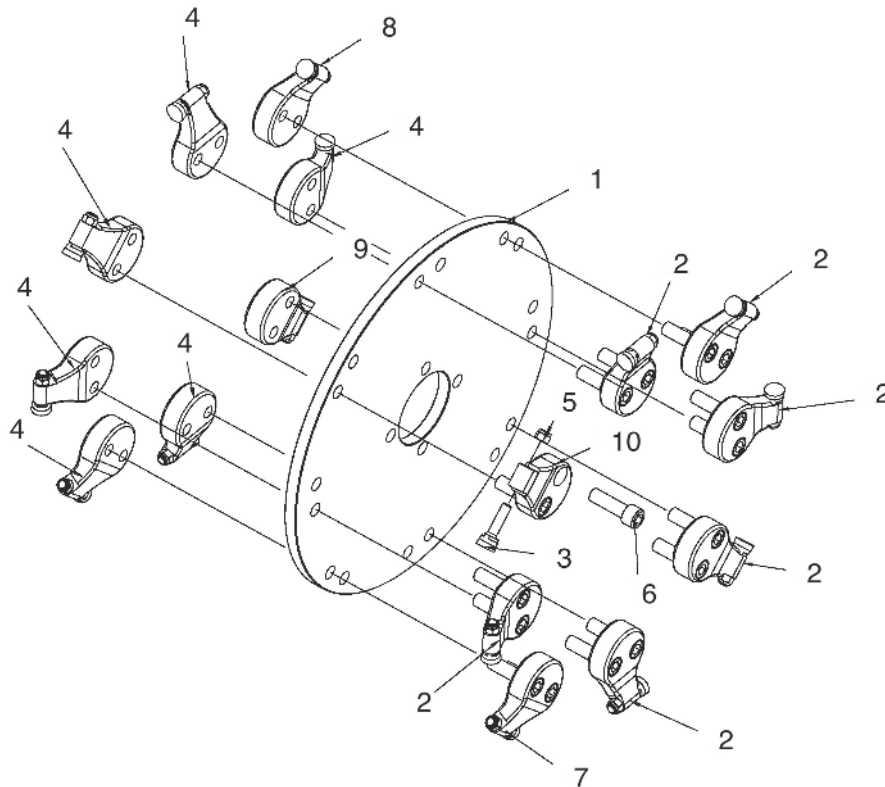

**PARTS LIST**

REF	DESCRIPTION	QTY
1	Cutting wheel	1
2	Teeth base900-2	6
3	Teeth 900	16
4	Teeth base900-3	6
5	Nylon Insert Lock Nuts	16
6	HEX SOCKET HEAD BOLT	16
7	Teeth base900-4	1
8	Teeth base900-5	1
9	Teeth base900-6	1
10	Teeth base900-1	1



# ***MechMaxx***

[info@mechmaxx.com](mailto:info@mechmaxx.com)

