

EN User Manual | Fridge Freezer



Welcome to our family

Thank you for bringing Frigidaire into your home! We see your purchase as the beginning of a long relationship together.

This manual is your resource for the use and care of your product. Please read it before using your appliance. Keep it handy for quick reference. If something doesn't seem right, the troubleshooting section will help you with common issues.

FAQ, helpful tips and videos, cleaning products, and kitchen and home accessories are available at <http://www.frigidaire.com>.

We are here for you! Visit our website, chat with an agent, or call us if you need help. We may be able to help you avoid a service visit. If you do need service, we can get that started for you.

Let's make it official! Be sure to register your product.

CONTENTS

1. IMPORTANT SAFETY INFORMATION.....	2
2. FEATURES.....	5
3. INSTALLATION.....	6
4. DOOR REMOVAL AND REVERSAL.....	9
5. DOOR HANDLE INSTALLATION.....	12
6. WATER SUPPLY CONNECTION.....	13
7. CONTROLS AND SETTINGS.....	14
8. AUTOMATIC WATER DISPENSER.....	16
9. ICE MAKER.....	17
10. STORAGE FEATURES.....	18
11. STORING FOOD AND SAVING ENERGY.....	20
12. NORMAL OPERATING SOUNDS.....	21
13. FILTER REPLACEMENT.....	21
14. CARE AND CLEANING.....	24
15. TROUBLESHOOTING.....	26
16. LIMITED WARRANTY.....	31
17. QUEBEC RIGHT TO REPAIR.....	32

1. IMPORTANT SAFETY INFORMATION

1.1 Keep a record for quick reference

Model number

.....

Serial number

.....

Purchase date

.....

1.2 Serial number location

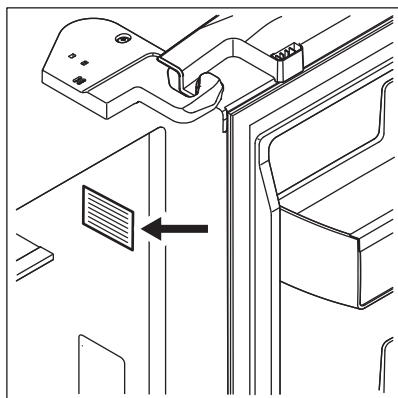

WARNING!

You must follow these guidelines to ensure that your appliance's safety mechanisms are operating correctly.

1.3 Safety definitions



This is the safety alert symbol. It is used to alert of potential personal injury hazards. Obey all safety messages that follow this symbol to avoid possible injury or death.

DANGER

DANGER indicates an imminently hazardous situation which, if not avoided, will result in death or serious injury.

WARNING!

WARNING indicates a potentially hazardous situation which, if not avoided, could result in death or serious injury.

CAUTION!

CAUTION indicates a potentially hazardous situation which, if not avoided, may result in minor or moderate injury.

IMPORTANT

IMPORTANT indicates installation, operation or maintenance information which is important but not hazard-related.

1.4 Child safety

This appliance is not intended for use by persons (including children) with reduced physical, sensory or mental capabilities, or lack of experience and knowledge, unless they have been given supervision or instruction concerning use of the appliance by a person responsible for their safety.

Destroy or recycle the carton, plastic bags, and any exterior wrapping material immediately after the appliance is unpacked. Children should never use these items to play. Cartons covered with rugs, bedspreads, plastic sheets or stretch wrap may become airtight chambers, and can quickly cause suffocation.



1.5 Important safety instructions

DANGER

  DANGER Risk of fire or explosion. Flammable refrigerant used. Do not use mechanical devices to defrost the appliance. Do not puncture refrigerant tubing.

DANGER Risk of fire or explosion. Flammable refrigerant used. To be repaired only by trained service personnel. Use only manufacturer-authorized service parts. Any repair equipment used must be designed for flammable refrigerants. Follow all manufacturer repair instructions. Do not puncture refrigerant tubing.

CAUTION!

  CAUTION Risk of fire or explosion due to puncture of refrigerant tubing. Follow handling instructions carefully. Flammable refrigerant used.

This appliance is for storage only and should not be used for any other purpose.

Do not store or use gasoline or other flammable vapors and liquids in the vicinity of this or any other appliance.

Do not store explosive substances such as aerosol cans with a flammable propellant in this appliance.

Do not operate the appliance in the presence of explosive fumes. Avoid contact with any moving parts of automatic ice maker.

Remove all staples from the carton. Staples can cause severe cuts, and also destroy finishes if they come in

contact with other appliances or furniture.

WARNING!



Do not use electrical appliances inside the food storage compartments of the appliance unless they are of the type recommended by the manufacturer.

WARNING!

CALIFORNIA RESIDENTS ONLY
WARNING! Cancer and Reproductive Harm <http://www.P65Warnings.ca.gov>

1.6 Proper disposal of your appliance

CAUTION!

  CAUTION Risk of fire or explosion. Dispose of the appliance properly in accordance with the applicable federal or local regulations. Flammable refrigerant used.

Risk of child entrapment

Child entrapment and suffocation are not problems of the past. Junked or abandoned appliances are still dangerous – even if they will sit for “just a few days”. If you are getting rid of your old appliance, follow the instructions below to help prevent accidents.

We strongly encourage responsible appliance recycling/disposal methods. Check with your utility company or visit <http://www.energystar.gov/recycle> for more information on recycling your old appliance.

Before you throw away your old appliance:

- Remove doors.
- Leave shelves in place so children may not easily climb inside.
- Have it removed by a qualified service technician.

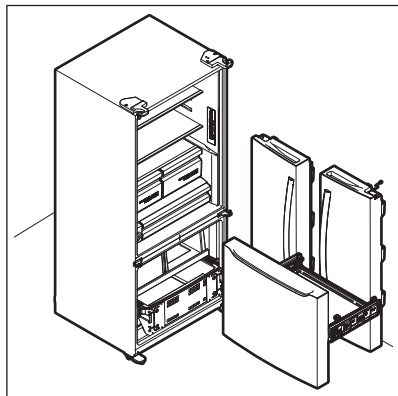

1.7 Electrical information

- The appliance must be plugged into its own dedicated 115 Volt, 60 Hz., 15 Amp, AC only electrical outlet. The power cord of the appliance is equipped with a three-prong grounding plug for your protection against electrical shock hazards. It must be plugged directly into a properly grounded three-prong receptacle. The receptacle must be installed in accordance with local codes and ordinances. Consult a qualified electrician. Do not use an extension cord or adapter plug.

WARNING!

Avoid fire hazard or electric shock.

- If the power cord is damaged, it should be replaced by an authorized service technician to prevent any risk.

- Never unplug the appliance by pulling on the power cord. Always grip the plug firmly, and pull straight out from the receptacle to prevent damaging the power cord.
- Unplug the appliance before cleaning and before replacing the light bulb to avoid electrical shock.
- Performance may be affected if the voltage varies by 10% or more. Operating the appliance with insufficient power can damage the compressor. Such damage is not covered under your warranty.
- Do not plug the unit into an electrical outlet controlled by a wall switch or pull cord to prevent the appliance from being turned off accidentally.
- Do not pinch, knot, or bend the power cord in any manner.

WARNING!

When positioning the appliance, ensure the supply cord is not trapped or damaged.

Do not locate multiple portable socket-outlets or portable power supplies at the rear of the appliance.

WARNING!

Do not, under any circumstances, cut, remove, or bypass the grounding prong (A). Always use the power cord with a three-prong grounded plug and grounding type wall receptacle.



2. FEATURES

IMPORTANT

Features may vary by model.

Accessories are available for your appliance and may be purchased at Frigidaire.com or by calling toll-free 1-800-374-4432.

2.1 Product overview

2-Door Model

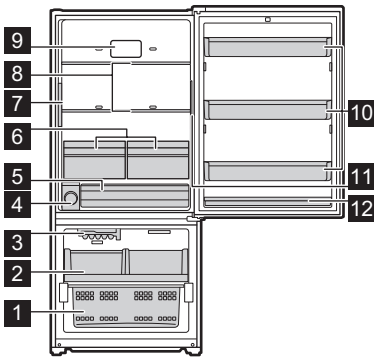

- 1 Lower Freezer Basket
- 2 Ice bin/Upper Freezer Basket
- 3 Ice Maker
- 4 Water Filter
- 5 Deli Drawer
- 6 Crispers
- 7 Internal Water Dispenser
- 8 Shelves
- 9 Air Filter
- 10 Door Bins
- 11 Appliance Control Display
- 12 Strap Bin

3-Door Model

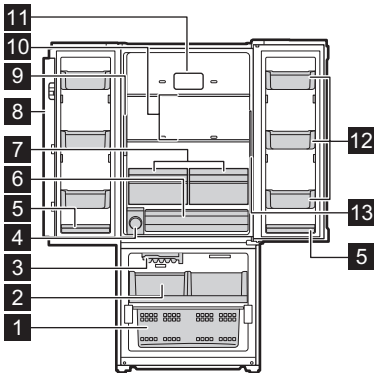

- 1 Lower Freezer Basket
- 2 Ice bin/Upper Freezer Basket
- 3 Ice Maker
- 4 Water Filter
- 5 Strap Bins
- 6 Deli Drawer
- 7 Crispers
- 8 Flipper Mullion
- 9 Internal Water Dispenser (some models)
- 10 Shelves
- 11 Air Filter
- 12 Door Bins
- 13 Appliance Control Display

3. INSTALLATION

This User Manual provides general installation and operating instructions for

your model. We recommend using a service or kitchen contracting professional

to install your appliance. Use the appliance only as instructed in this User Manual. Before starting the appliance, follow these important first steps.

3.1 ✓ Installation Checklist

Doors

- Handles are secure and tight
- Door seals completely the cabinet on all sides

Leveling

- Refrigerator is level side-to-side and slightly elevated in front to assist with door and drawer closing. Front should be higher than back.
- Cabinet is setting solid on all corners

Electrical Power

- House power is turned on
- Appliance is plugged in

Ice Maker

- House water supply is connected to the appliance

WARNING!

Potable water supply only.

- No water leaks present in any connections - recheck in 24 hours
- Ice maker is turned on
- Ice and water dispenser operates correctly

Final Checks

- Shipping material is removed
- Refrigerator and freezer temperatures are set
- Registration card is sent in

3.2 Tools necessary

These tools are necessary at different stages of the installation process:

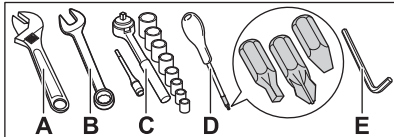

- A. Adjustable Wrench
- B. 3/8" Fixed Wrench
- C. 3/8" and 1/4" Socket Wrench
- D. Screwdriver: Phillips™ Head or Quadrex Head
- E. 6 mm Allen Wrench

Components Provided

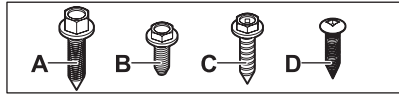

- A. Top hinge screw
- B. Top hinge cover front screw
- C. Top hinge cover rear screw
- D. Lower hinge screw

3.3 Location

- If possible, place the appliance out of direct sunlight and away from the range, dishwasher, or other heat sources.
- The appliance must be installed on a floor that is level and strong enough to support a fully loaded appliance.
- Consider water supply availability for models equipped with an automatic ice maker.

WARNING!

This appliance is intended for use in residential household and similar interior applications such as:

- Kitchen / kitchenette
- Pantry room
- Basement
- Enclosed garage
- Other interior residential type environments

WARNING!

Allow the following clearances for ease of installation, proper air circulation, plumbing, and electrical connections:

- Top 3/8" (9.5 mm)
- Sides 3/8" (9.5 mm)
- Back 1" (25.4 mm)

NOTE

If you place the appliance with the door hinge side against a wall, you may have to allow additional space so the door can be open wider.

3.4 Door opening

Position the appliance to allow easy access to a counter when removing food. Make sure the refrigerator drawers and freezer baskets can be fully open.

3.5 Cabinet leveling and door alignment

Guidelines for final positioning of appliance:

- All 4 corners of the cabinet must rest firmly on the floor.
- Slightly elevate the front to ensure that doors close and seal properly.
- Align the doors with each other and level them.

You can meet most of these conditions by raising or lowering the adjustable front feet.

3.6 Flipper mullion

Adjust the flipper mullion for proper connection with the mullion guide. Ensure the flipper mullion is folded and perpendicular to the fresh food door. If the mullion guide is not in the correct position, it could prevent the door from closing completely.

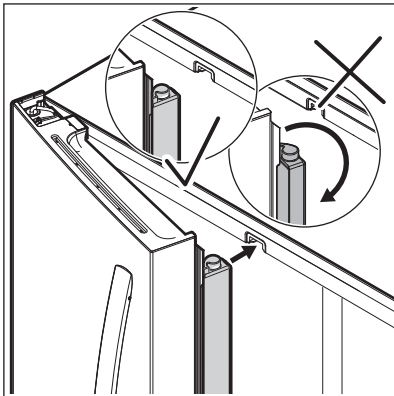

3.7 Leveling

Level the cabinet by raising or lowering the adjustable front rollers.

1. Slightly open freezer drawer to reveal adjustable rollers at bottom of cabinet.
2. Use the front roller height adjusting screws to make initial cabinet adjustments. Use a 3/8" socket wrench to turn the adjustment screws (1 per side).
 - Turn adjustment screw clockwise to raise the unit.

- Turn adjustment screw counterclockwise to lower the unit.

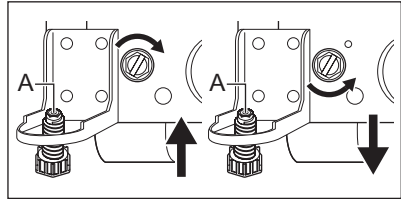

3. Ensure both doors are bind-free with their seals touching the cabinet on all 4 sides and that cabinet is stable.
4. After unit is leveled, lower the anti-tip leg (A) until it firmly contacts the floor. An adjustable wrench may be necessary for adjustment.

3.8 Door Alignment

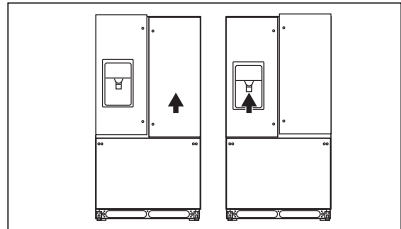

To align the door:

1. Take the washers from the plastic bag.
2. Lift the lower door up and insert the washer on the center hinge pin.
3. If necessary, repeat the steps on the other side of the appliance.

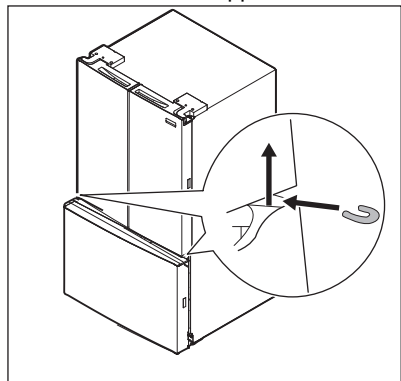

4. DOOR REMOVAL AND REVERSAL

4.1 Getting through narrow spaces

If your appliance does not fit through an entrance area, you can remove the doors. Check first by measuring the entrance.

4.2 Removing/Installing refrigerator doors

⚠ CAUTION!

The door is heavy. We recommend two people to remove or replace the door assembly from the cabinet.

🔩 NOTE

Do not use an electric tool to unscrew and screw parts.

To prepare for removing the doors:

1. Unplug the electrical power cord from the wall outlet.
2. Remove any food from the door shelves and close the doors.

⚠ WARNING!

Make sure the electrical power cord is unplugged from the wall outlet.

To remove refrigerator doors:

1. Trace lightly around the door top hinges with a pencil. This makes reinstallation easier. Remove the screw from the top hinge cover.

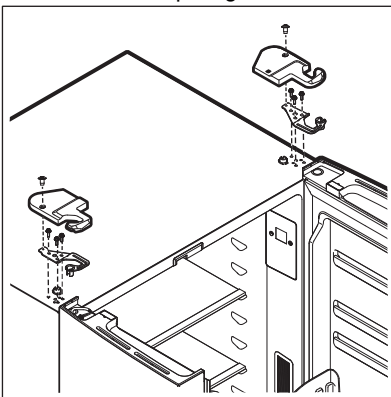

2. Disconnect electrical harness running from door to hinge cover.

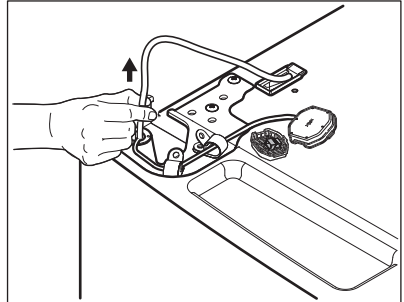

3. Remove three 8 mm bolts from both top hinges. Lift the doors up off lower hinges and carefully set aside.

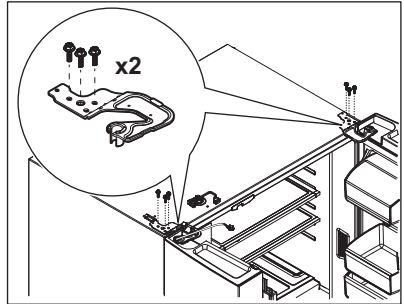

⚠ CAUTION!

Place the doors aside in a secure position where they cannot fall and cause personal injury or damage to the doors.

4. To gain access to the lower hinge, extend the drawer. Unscrew the lower hinge screws to remove the hinge.

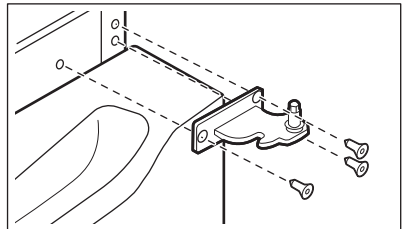

5. To reinstall doors, reverse the procedure.

Once both doors are in place, ensure they are aligned with each other and level and replace the top hinge cover. Refer to Installation.

Door Removal

For the 2-door models only:

1. With the door closed, use a plastic putty knife to remove the left hand top hinge cover. Then, unsnap the right hand top hinge cover and set both aside. Remove the three 8mm screws from the top hinge.

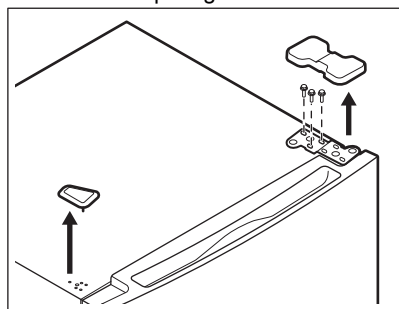

2. Open the refrigerator door, and lift the door off of center hinge pin. Set the door aside.
3. If the center hinge is still preventing access through the entryway, open the bottom drawer and remove the center hinge pin using an adjustable wrench and set aside. Remove the center hinge by unscrewing the three center hinge screws.
4. To reinstall the door, reverse the procedure.

4.3 Removing The Freezer Drawer

To remove the freezer drawer:

1. Open and fully extend the drawer.
2. Remove the freezer bins and basket.
3. Inside the cabinet, press the 2 tabs on both sides to release the sliders.
4. Remove the drawer with brackets and sliders.

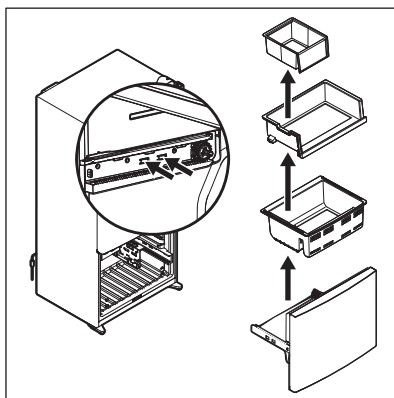

To reinstall the freezer drawer:

1. Place the drawer with brackets and sliders inside the cabinet and click into place.
2. Replace the basket and bins.

NOTE

Once the doors are in place, ensure they are aligned and level. Refer to Installation. Replace the top hinge cover.



For additional instructions, refer to Storage Features

4.4 Door Reversal

For the 2-door models only:

NOTE

For the following steps, find replacement parts in the plastic bags located in the crispers.

CAUTION!

The door is heavy. We recommend two people to remove or replace the door assembly from the cabinet.

NOTE

Place the doors on a padded surface to avoid damage where they cannot fall and cause personal injury.

1. With the door closed, use a plastic putty knife to remove the left top hinge

cover. Unsnap the right top hinge cover and set both aside. Remove the three 8 mm screws from the top hinge. Carefully remove the door from the appliance and set aside.

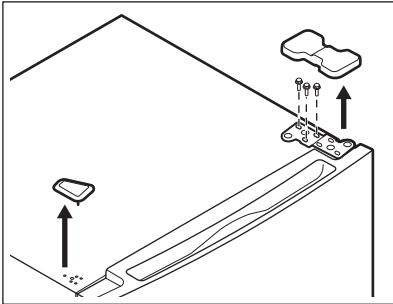

2. Unscrew the center hinge pin using an adjustable wrench and set it aside.

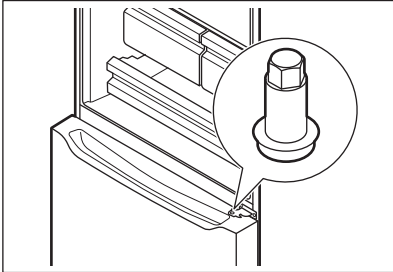

3. Using the putty knife remove the 3 plastic plugs on the left side.

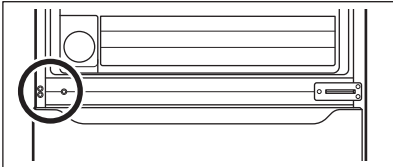

4. Open the freezer drawer to prevent damaging the appliance while you remove the center hinge. Using a T20 Torx driver, remove the 3 screws from the center hinge. Flip the center hinge over and install it on the left side of the appliance.

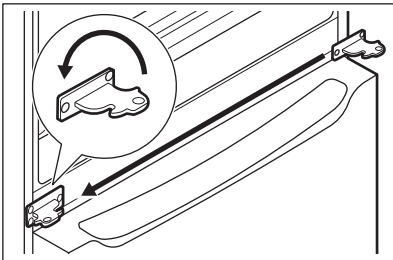

5. Screw in and fully tighten the center hinge pin on the left side using an adjustable wrench.
6. Take the 3 new plastic plugs from the door reversal kit located in the crisper, and install them on the right side.

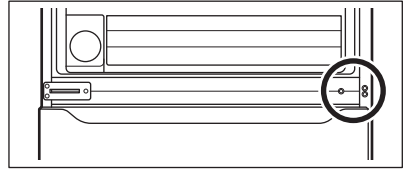

7. Flip the refrigerator door over.
- Remove the screw from the auto-closer hook using a Phillips head screwdriver and set it aside.
 - Pry out the hinge bearing from the door with a flat head screwdriver.
 - Install the bottom hinge bearing on the opposite side of the door. Flip the auto-closer hook over. Using the Phillips head screwdriver, screw in the auto-closer and fully tighten.

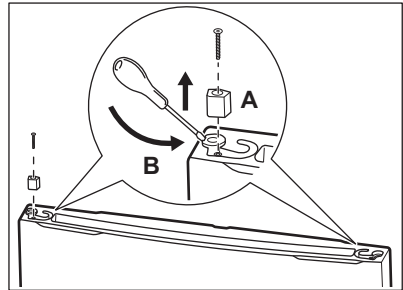

8. Take the left side top hinge from the door reversal kit located in the crisper.
9. Apply 1/4 of the grease packet, from the door reversal kit, inside the hole on the door for the top hinge to ensure proper door operation.

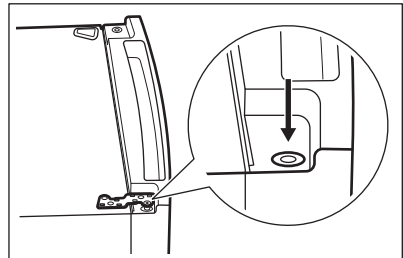

10. Lower the refrigerator door onto the center hinge pin at a 90° angle and close the door.

11. Align the holes of the top hinge with the cabinet holes and reinsert the three 8mm screws. Do not fully tighten the screws.

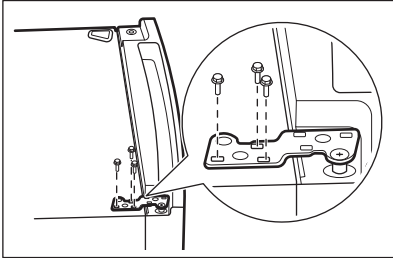

12. Ensure the door has approximately 0.68inch (17.5mm) between the refrigerator door and the freezer drawer. Once level, securely tighten

the hinge screws. Replace the top hinge covers.

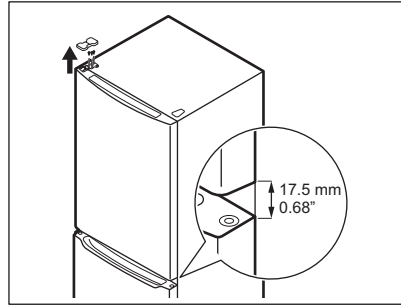

13. Reconnect the electrical power cord to the wall outlet.

5. DOOR HANDLE INSTALLATION

⚠ CAUTION!

Wear gloves and safety goggles. Use extreme caution when installing these handles.

The rounded end of the handles may be sharp (some models).

5.1 Door handle installation

🔩 NOTE

Part quantities vary per model.

To install the door handle:

1. Position the handle over the handle mounts.

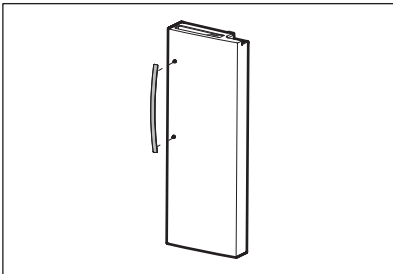

2. Turn the Allen set screw on the top of the handle clockwise using the Allen wrench. Tighten to secure the handle. Repeat for the bottom of the handle.

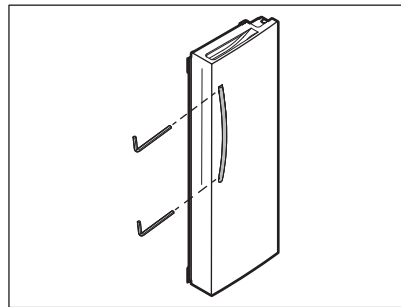

🚫 IMPORTANT

When tightening the Allen set screws, it is important to apply force to the longer arm of the Allen wrench.

Tighten all set screws so the screw is below the surface of the handle. Draw the handles tight to doors with no gaps.

🔩 NOTE

The door handle may loosen over time or if it was installed improperly. If this happens, tighten the set screws on the handles.

6. WATER SUPPLY CONNECTION

6.1 Before Installing The Water Supply Line

⚠ WARNING!

To avoid electric shock, which can cause death or severe personal injury, disconnect the appliance from the electrical power before connecting a water supply line to the appliance.

⚠ CAUTION!

To avoid property damage:

- Use copper or stainless steel braided tubing for the water supply line. Do not use water supply tubing made of 1/4" plastic. Plastic tubing greatly increases the potential for water leaks, and the manufacturer will not be responsible for any damage if you use plastic tubing for the supply line.
- Do not install water supply tubing in areas where temperatures fall below freezing.
- Chemicals from a malfunctioning softener can damage the ice maker. If the ice maker is connected to soft water, ensure that the softener is maintained and working properly.

🔑 IMPORTANT

Ensure your water supply line connections comply with all local plumbing codes.

6.2 You will need

- Basic tools: adjustable wrench, flat-blade screwdriver, and Phillips™ screwdriver.
- Access to a household cold water line with water pressure between 30 and 100 psi.
- A water supply line made of 1/4" (6.4 mm) OD, copper or stainless steel tubing. To determine the length of tubing needed, measure the distance from the ice maker inlet valve at the back of the appliance to your cold water pipe. Then add approximately 6 ft

(1.8 m) to ensure you can move the appliance for cleaning.

- A shutoff valve to connect the water supply line to your household water system. Do not use a self-piercing type shutoff valve.
- Do not reuse compression fitting or use thread seal tape.
- A compression nut and ferrule (sleeve) for connecting a copper water supply line to the ice maker inlet valve.

📌 NOTE

Check with your local building authority for recommendations on water lines and associated materials prior to installing your new refrigerator. Depending on your local/state building codes, Frigidaire recommends:

- for homes with existing valves Smart Choice® water line kit 5305513409 with a 6 ft (1.8 m) stainless steel water line.
- for homes without an existing valve Smart Choice® water line kit 5305510264 with a 20 ft (6 m) copper water line with self-tapping saddle valve.

Please refer to Frigidaire.com for more information.

6.3 Installing the Water Supply Line

To connect water tube to household water supply:

1. Disconnect refrigerator from electric power source.
2. Place end of water supply line into sink or bucket. Turn on water supply and flush supply line until water is clear. Turn off water supply at shutoff valve.

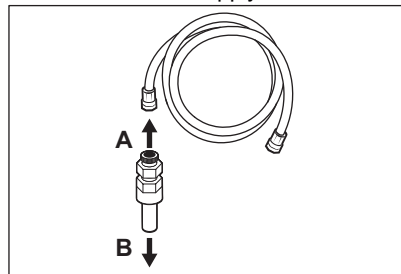

- A. To household water supply
 - B. To unit water valve
3. Open the locking clips and grab the water line coming from the refrigerator. Remove the plastic cap from the water inlet fitting and discard the cap.

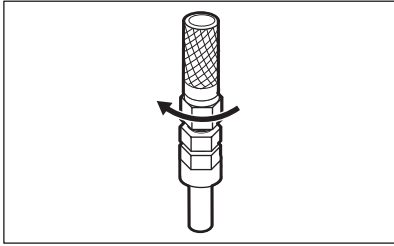

4. If using (recommended) stainless steel braided tubing - the nut and the ferrule are already assembled on the tubing. Slide the compression nut onto the water inlet fitting and finger tighten.
5. Using two 1/2" wrenches, one to hold the household water line nut (A) and the other to hold the water inlet fitting nut (B), tighten a half turn with the wrench (A). Do not over tighten.

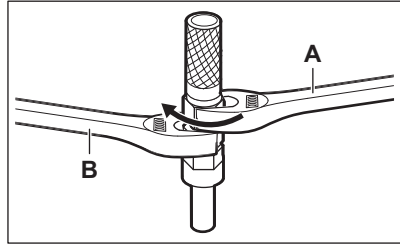

6. Replace the connected tubes into the clips and lock the clips back in place to keep the tubing in the right position.
7. Turn on water supply at shutoff valve and tighten any connections that leak.
8. Reconnect refrigerator to electrical power source.
9. Turn the ice maker on.
10. Purge air from the Ice and Water Dispenser System by operating the water dispenser for 3 - 4 minutes. This requires dispensing several glasses of water.

7. CONTROLS AND SETTINGS

7.1 Control Panel

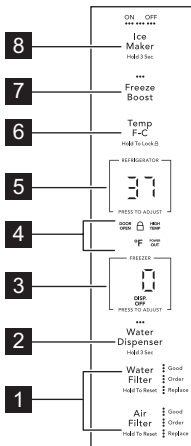

1. **Air/Water Filter** button
Replace the filter when the indicator illuminates Replace. To reset the filter status to Good, press the button for 3 seconds.
2. **Water Dispenser** button

The button illuminates when the internal water dispenser is on. Press the button for 3 seconds to turn the dispenser off.

3. **Freezer Temperature** indicator
Press to adjust the temperature. Temperatures vary from -6°F (-21°C) to 4°F (-15°C)
4. **Alarms** indicators
5. **Refrigerator Temperature** indicator
Press to adjust the temperature. Temperatures vary from 33°F (-1°C) to 43°F (6°C)
6. **Temp F-C** button
Press to toggle from Fahrenheit to Celsius.
7. **Freeze Boost** button
Prior to grocery shopping we recommend to activate the Freeze Boost to freeze your food faster. It remains active for up to 12 hours before automatically deactivating or after manual exit. Press the button to activate the function. This resets the freezer to the previous temperature setting.
8. **Ice Maker** button

Press and hold for 3 seconds to turn the ice maker on/off.

7.2 Air Vents

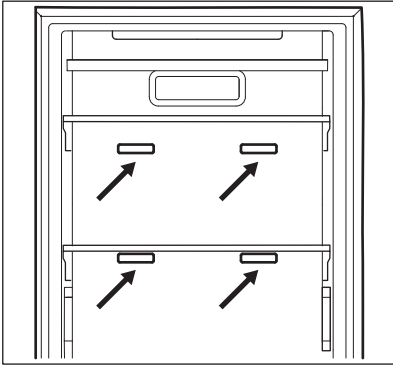

Do not place items in front of the air vents as this impacts the temperature performance.

7.3 Clear Alerts

Door Open

If you leave freezer or refrigerator doors open for 5 minutes or more, the alarm sounds and the Door Open indicator illuminates on the control display. Close the door and press any key to reset the alarm.

High Temp Alarm

HI flashes on the display. The alarm sounds every 10 seconds. Press any key to acknowledge the alarm. The highest temp value displays when you first acknowledge the alarm.

Power Outage

In the event of a power outage, POWER OUT illuminates. Once power is restored the tone sounds. Press any key to deactivate the tone.

7.4 Sabbath Mode

NOTE

While in Sabbath Mode, neither the lights, dispenser, nor the control panel will work until Sabbath Mode is deactivated. Refrigerator stays in Sabbath Mode after power failure recovery. It must be deactivated with the buttons on the control panel.

NOTE

Although you have entered the Sabbath Mode, the ice maker will complete the cycle it had already initiated. The ice cube compartment will remain cold and new ice cubes can be made with standard trays.

The Sabbath Mode is a feature that disables portions of the refrigerator and its controls in accordance with observance of the weekly Sabbath and religious holidays within the Orthodox Jewish community.

To activate/deactivate Sabbath Mode, simultaneously press and hold both: TEMP F-C, REFRIGERATOR for 5 seconds. The display shows Sb while in Sabbath mode.

In the Sabbath Mode, the High Temp is active for health reasons. For example, if you leave the door ajar High Temp activates. The refrigerator functions normally once you close the door, without any violation of the Sabbath/Holidays. The High Temp activates when the cabinet temperature is outside the safe zone.



For further assistance, guidelines for proper usage and a complete list of models with the Sabbath feature, visit the web at star-k.org.

8. AUTOMATIC WATER DISPENSER

8.1 Priming the Water Supply System

CAUTION!

For proper dispenser operation, the recommended water supply pressure should fall between 30 psi and 100 psi. Excessive pressure may cause the system to malfunction.

Before dispensing water for the first time, be sure to prime the water supply system. If you do not flush the system, the first glasses of water may have discolored water or have an odd flavor.

1. Ensure the dispenser is enabled. Refer to Controls and Settings.
2. Begin filling the system by pressing and holding a drinking glass against the water dispenser paddle.
3. Keep the glass in this position until water comes out of the dispenser. It may take about 4 minutes to purge air from the system.
4. Continue dispensing water for about 1 full gallon. Stop to empty the glass if necessary.



If you prefer to keep the internal water dispenser disabled, use the appliance control display to disable it.

Place a cup against the paddle and press to dispense water.

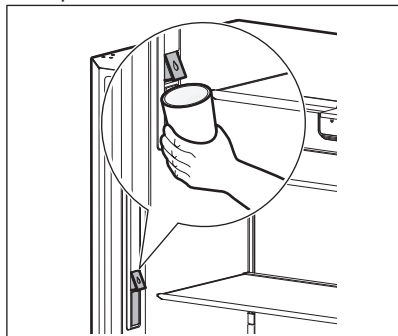

8.2 Using the dispenser

Your appliance arrives with the water dispenser already activated and ready to use.

1. Ensure the dispenser is on.
2. Place a cup against the paddle and press to dispense water.

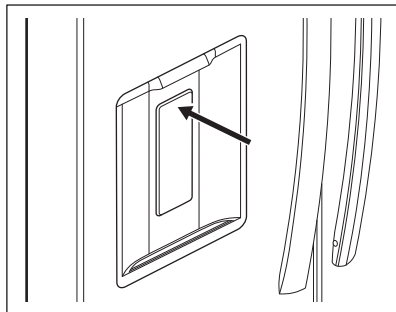

CAUTION!

Hold the door with one hand while dispensing water to keep the door from moving and possible dispensing water on floor.

NOTE

If you prefer to keep the internal water dispenser disabled, use the appliance display to disable it. The LEDs are not illuminated above Water Dispenser.

9. ICE MAKER

9.1 Ice Maker Tips

The following sounds are normal when the ice maker is operating:

- Motor running
- Ice dropping into ice bin
- Water valve opening or closing
- Running water
- Ice loosening from tray

Ice cubes stored too long may develop an odd flavor. Empty the ice bin.

If you turn the ice maker off for a long period of time, turn the water supply valve to the closed position.

Evenly distribute the ice in the container to avoid clumps.

Keep the ice maker off until the ice maker is connected to the water supply or whenever the water supply is turned off.

NOTE

Water quality determines the ice quality.

CAUTION!

If the water supply to your refrigerator is softened, properly maintain the softener. Chemicals from a water softener can damage the ice maker.

CAUTION!

- Do not place the ice bin in the dishwasher.
- Wash the ice bin with warm water and mild detergent. Rinse well and dry.
- Turn off the ice maker when cleaning the freezer and during vacations.

9.2 Turning Ice Maker On/Off

After connecting the plumbing, open the water supply valve.

The ice maker regulates the ice production. It stops making ice when full and resumes when ice is low in the ice bin.

To turn the Ice Maker on/off:

Press ICE MAKER on the control display to turn the ice maker on/off. The LEDs above the button illuminate.

When ice maker is turned off on the appliance control display, the ice maker does not produce ice.

Remove the Ice Bin if:

An extended power failure (1 hour or longer) cause ice cubes in the ice bin to melt and re-freeze together after power is restored.

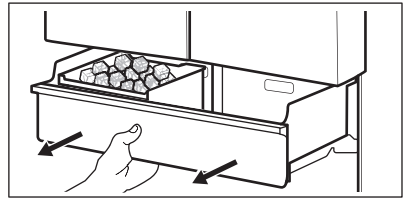

To remove ice bin lift it upward and pull straight out. Shake to loosen the cubes or clean.

CAUTION!

Never use an ice pick or similar sharp instrument to loosen the ice cubes. This could damage the ice bin. To loosen ice clumps, use warm water. Before replacing the ice bin, ensure it is completely dry.

9.3 Ice production

The ice maker produces about 3.5 lbs of ice every 24 hours depending on usage conditions. When completely full, the bins hold about 8 lbs of ice.

NOTE

Set the freezer to a colder setting to increase the output of the ice maker. Allow 24 hours for the temperature to stabilize.

NOTE

Do not place the ice container in a dishwasher.

10. STORAGE FEATURES

Equipment varies by model.

10.1 Shelves

⚠ CAUTION!

To avoid personal injury or property damage, handle tempered glass shelves carefully. Shelves may break suddenly if nicked, scratched, or exposed to sudden temperature change. Allow the glass shelves to stabilize to room temperature before cleaning. Do not wash in dishwasher.

You can easily adjust shelf positions in the refrigerator compartments to suit your needs. The shelves have mounting brackets that attach to slotted supports at the rear of each compartment.

1. Remove all the food from the shelf.
2. Lift the front edge up and pull the shelf out.

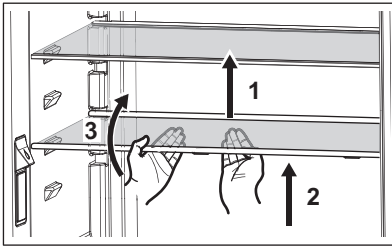

3. Replace by inserting the mounting bracket hooks into the desired support slots.
4. Lower the shelf and lock into position.

10.2 Removing/Installing crisper drawers with PureAir Produce Keeper™

You can remove the drawer for cleaning. To remove the drawer:

1. Pull the drawer out until it stops.
2. Lift the front slightly and remove the drawer.

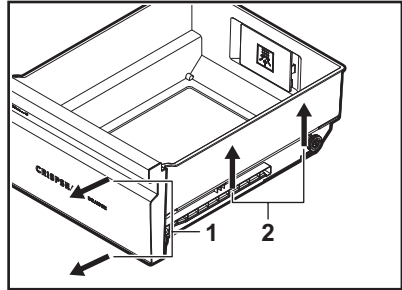

⚠ CAUTION!

Remove the produce keeper prior to washing the crisper.

To install the drawer:

1. Place the crisper on top of the deli cover and tilt upward slightly.

📌 NOTE

The gasket should be on the outside wall of the crisper after being removed and reinstalled into the unit.

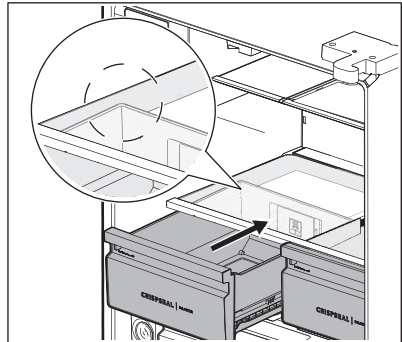

2. Push the crisper straight once the bottom rollers clear the front deli crisper support rollers.

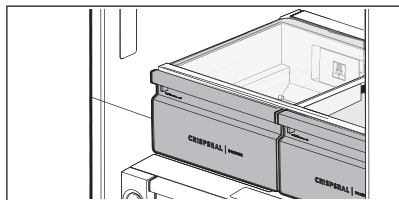

10.3 Auto-humidity Control Removal

To remove the auto humidity control membrane for cleaning:

1. Reach to the back of the humidity control cover.
2. Place your fingers between the humidity control and the back wall. Pull up on the cover.
3. Pull the cover toward the front of the cabinet and remove it.

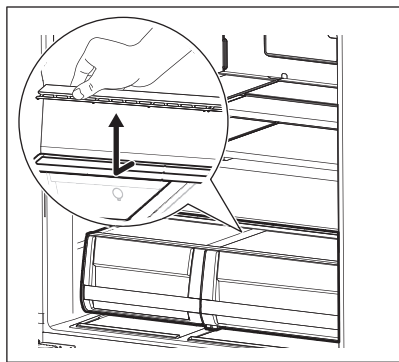

4. Remove the humidity membrane from the housing by lifting it up and sliding it over.

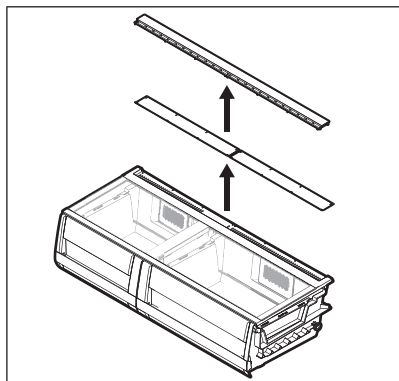

5. Clean the humidity membrane with hot, soapy water.

6. Replace the membrane in the housing by reversing the steps above.



We do not recommend replacing the auto-humidity membrane unless it becomes damaged or ruined. If the membrane becomes soiled, you can wash it with soap and water. Ensure the membrane is dry before replacing it in the housing.

10.4 Doors

Storage bins (varies by model)

The doors to your refrigerator compartment use a system of modular storage bins. All of these bins are removable for easy cleaning. Some of them have fixed positions, while others can be adjusted to your needs.

Door bins are ideal for storing jars, bottles, cans, and large drink containers. They also enable quick selection of frequently used items.

Adjustable door bins

Adjustable door bins are designed to hold containers, bottles or storage bags. Each bin can be removed or adjusted to suit individual needs.

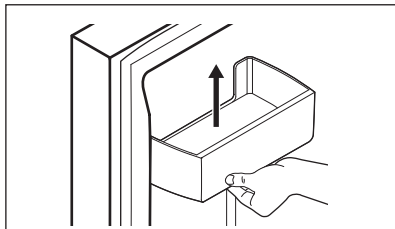

To move door bin side to side:

1. Tilt the bin up so the back is off the door but the hook is still engaged.
2. Slide the bin along the rail to the desired position.
3. Lower the bin back into place.

To move door bin up or down:

1. Lift the bin up to disengage the hook.
2. Move the bin to the desired rail location.
3. Push the bin hook into the rail to engage the hook.

11. STORING FOOD AND SAVING ENERGY

11.1 Ideas for storing food

Fresh food storage

- Keep the fresh food compartment between 34°F and 40°F, with an optimum temperature of 37°F.
- Avoid overcrowding the refrigerator shelves, which reduces air circulation and causes uneven cooling.
- Avoid placing food in front of air ports.

Fruits and vegetables

- Store fruits and vegetables in crisper drawers, where trapped moisture helps preserve food quality for longer time periods.
- Wash items and remove excess water.
- Wrap any items that have strong odors or high moisture content.

Meat

- Wrap raw meat and poultry separately and securely to prevent leaks and contamination of other foods or surfaces.
- Use the deli drawer to store meat/poultry for short-term storage. Any meat to be kept longer than two days should be frozen.

Frozen foods storage

- Keep the freezer compartment at 0°F or lower.
- A freezer operates most efficiently when it is at least 2/3 full.

Packaging foods for freezing

- To minimize food dehydration and quality deterioration, use aluminum foil, freezer wrap, freezer bags, or airtight containers. Force as much air out of the packages as possible and seal them tightly. Trapped air can cause food to dry out, change color, and develop an off-flavor (freezer burn).
- Wrap fresh meats and poultry with suitable freezer wrap prior to freezing.
- Do not refreeze meat that has completely thawed.

Loading the freezer

- Prior to grocery shopping, activate Freeze Boost so that on your return you can ensure your newly purchased food designated for the freezer will be preserved as quickly as possible.

- Activating Freeze Boost also will help your freezer more efficiently maintain the selected temperature after placing new purchases with pre-existing frozen foods.
- Avoid adding too much warm food to the freezer at one time. This overloads the freezer, slows the rate of freezing, and can raise the temperature of frozen foods.
- Leave a space between packages, so cold air can circulate freely, allowing food to freeze as quickly as possible.

11.2 Ideas for energy saving

Installation

- Locate the refrigerator in the coolest part of the room, out of direct sunlight, and away from heating ducts or registers.
- Do not place the refrigerator next to heat-producing appliances such as a range, oven, or dishwasher. If this is not possible, a section of cabinetry or an added layer of insulation between the two appliances will help the refrigerator operate more efficiently.
- Level the refrigerator so that the doors close tightly.

Temperature setting

- Refer to Controls and Settings for procedures on temperature settings.

Food storage

- Avoid overcrowding the refrigerator or blocking cold air vents. Doing so causes the refrigerator to run longer and use more energy.
- Cover foods and wipe containers dry before placing them in the refrigerator. This cuts down on moisture build-up inside the unit.
- Organize the refrigerator to reduce door openings. Remove as many items as needed at one time and close the door as soon as possible.
- Do not place a hot container directly on a cold shelf. Remember, such an extreme temperature change may damage the glass.

12. NORMAL OPERATING SOUNDS

12.1 Understanding the sounds you may hear

Your new, high-efficiency appliance may introduce unfamiliar sounds. These sounds normally indicate your appliance is operating correctly. Some surfaces on floors, walls, and kitchen cabinets may make these sounds more noticeable.

NOTE

Energy efficient foam in your appliance is not a sound insulator.

Following is a list of major components in your appliance and the sounds they can cause:

- A. Evaporator. Refrigerant through the evaporator may create a boiling or gurgling sound.
- B. Evaporator fan. You may hear air being forced through the refrigerator by the evaporator fan.
- C. Defrost heater. During defrost cycles, water dripping onto the defrost heater may cause a hissing or sizzling sound. After defrosting, a popping sound may occur.
- D. Automatic Ice maker. When ice has been produced, you will hear ice cubes falling into the ice bin.
- E. Electronic control & automatic defrost control. These parts can produce snapping or clicking sound when turning the cooling system on and off.
- F. Compressor. Modern, high-efficiency compressors run much faster than previous models. The compressor may have a noticeable hum or pulsating sound during operation.
- G. Water valve. Makes a buzzing sound each time it opens to fill the ice maker.
- H. Drain pan (not removable). You may hear water dripping into the drain pan during the defrost cycle.
- I. Motorized damper. May produce intermittent humming during operation.

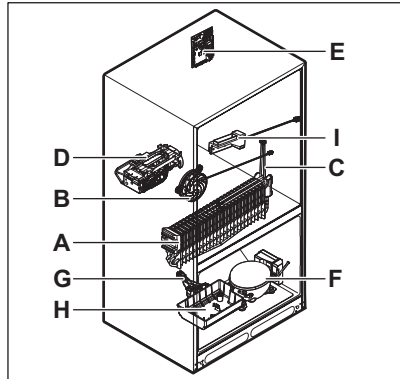

NOTE

During automatic defrost cycle, a red glow in the back wall vents of your freezer compartment is normal.

13. FILTER REPLACEMENT

13.1 PurePour Connect™ Water Filter

Keep safe, great-tasting water flowing with a PurePour Connect™ water filter. Using a PurePour Connect™ water filter:

- **Makes safe water second nature**
PurePour Connect™ water filters are certified to reduce contaminants* and keep great-tasting water flowing for you and your family.
- **Produces purity you can trust**
Know for certain your PurePour Connect™ water filter is a protector.

Counterfeits and knockoffs put your refrigerator and health at risk. Frigidaire Genuine Filters are the smarter, safer choice.

- **Every drop gives back**
Partnered on sustainability efforts the use of a PurePour Connect™ water filter helps cut back on the cost and use of plastic used to produce and package bottled water

*For the complete list, please see Performance Data Sheet on Frigidaire.com.

13.2 Ordering replacement filters

NOTE

When you order your replacement filter, please reorder the same filter type currently in your refrigerator.

To order your replacement filters, please call toll-free at 1-800-374-4432, or visit Frigidaire.com. Frigidaire recommends that you order extra filters when you first install your appliance, and that you replace your filters at least once every 6 months.

Here are the product numbers to request when ordering:

PurePour Connect™ Water Filter
PWF-1™ FPPWFO1

Find the [Performance Data Sheet](#) located in the Guides and Manuals section for your specific water filter on Frigidaire.

13.3 More about your advanced water filter



The PurePour Connect™ PWF-1™ FPPWFO1, PurePour Connect™ PWF-2™ FPPWFO2 ice and water filter system is tested and certified by IAPMO R&T against Standards 42, 53, 401 and NSF/ANSI/CAN 372CSA B483.1 in PurePour Connect™ PWF-1/PWF-2 for the reduction of claims specified on the Performance Data Sheet. Visit Frigidaire.com for more information.

Do not use with water that is microbiologically unsafe or of unknown quality without adequate disinfection before or after the system. Use systems certified for cyst reduction on disinfected waters that may contain filterable cysts.

Test & certification results

- Rated Capacity - 125 gal / 453 L for PurePour Connect™ and ice and water filter
- Rated service flow - .50 gal/min
- Operating Temperature: Minimum: 33°F, Maximum: 100°F
- Maximum rated pressure - 100 lbs/in²
- Recommended minimum operating pressure: 30 lbs/in²

13.4 Replacing your PurePour Connect™ water filter

The water filter is located at the bottom left of the refrigerator compartment next to the Deli Drawer.

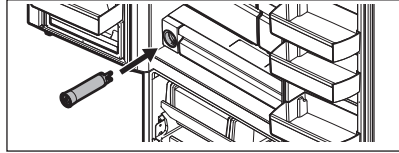

In general, you should change the water filter every 6 months to ensure the highest possible water quality. Water Filter Status on the user interface prompts you to replace the filter after a standard amount of water (125 gal / 453 L for PurePour Connect™) has flowed through the system.

If you have not used your appliance for a period of time (during moving for example), change the filter before reinstalling the appliance.

It is not necessary to turn the water supply off to change the filter. Small amounts of water may be released during the filter replacement.

1. Turn off the ice maker.
2. Remove the filter by pushing on the end/face of the filter.
3. Slide the old water filter cartridge straight out of the housing and discard it.
4. Unpack the new filter cartridge. Using the alignment guide, slide it gently into the filter housing until it stops against the snap-in connector at the back of the housing.
5. Push firmly until the cartridge snaps into place. There is a clicking sound as the cartridge engages with the snap-in connector.
6. Press a drinking glass against the water dispenser while checking for any leaks at the filter housing. Any spurts and sputters that occur as the system purges air out of the dispenser system are normal.
7. After filling one glass of water, continue flushing the system for about 4 minutes.
8. Turn on the ice maker.
9. Press and hold the Water Filter reset button on the Ice and Water Dispenser

control panel for 3 seconds. When the display changes from red to green, the status is reset.

13.5 PureAir™ RAF-1 Air Filter

The air filter is located at the top of the air tower.

To order replacement filters, please visit our online store at Frigidaire.com or call toll-free at 1-800-374-4432. Here are the product numbers to request when ordering:

- PureAir™ RAF-1 Air Filter FRGPAAF1

NOTE

We recommend you always use genuine Frigidaire replacement filters only.

13.6 Replacing your PureAir™ RAF-1

To ensure optimal filtering of refrigerator odors, you should change the air filter every 6 months. The filter status light on the main controls prompts you to replace the filter after 6 months.

To remove and replace the air filter:

1. Place fingers on top of air cover and gently pull towards front of unit releasing the top snaps on the cover from the air tower.
2. Lift bottom snaps up and out of air tower assembly to disengage and remove front cover.
3. Replace air filter by snapping filter into snaps on air filter cover.
4. Installation of front cover is reverse of removal.
5. To reset Air Filter status, refer to Controls and Settings.

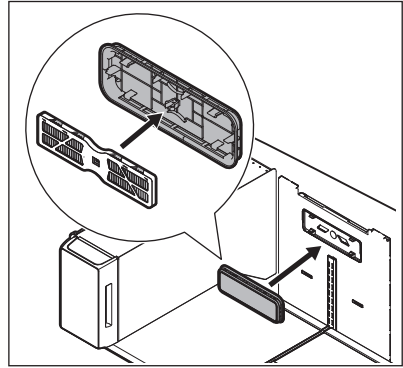

13.7 PureAir Produce Keeper Plus™

NOTE

PureAir Produce Keeper Plus™ accessories are optional and may be installed in most models at any time. Visit Frigidaire.com for information about PureAir Produce Keeper Plus™ PK-2 accessories. Part # FRPAPK2RF.

Keep fruits and vegetables fresher longer with PureAir Produce Keeper Plus™. Our produce keeper absorbs ethylene gas, the natural gas that causes produce to ripen quicker. Reduce food waste, save money and enjoy fresh-tasting produce with a longer storage life.

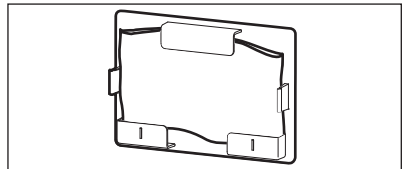

Ordering Base Starter Kit

To keep food fresh for longer, you can purchase PureAir Produce Keeper Plus™ Base Starter Kit, one for each crisper drawer.

Here are the product numbers to request when ordering:

Part #FRPAPK2SKT

Ordering Replacement Filters

To order your replacement filters, please visit our online store at Frigidaire.com, by calling toll-free at 1-800-374-4432, or by

visiting the dealer where you purchased your refrigerator. Frigidaire recommends that you replace your filters at least once every 6 months.

Here are the product numbers to request when ordering:

PureAir Produce Keeper Plus™ PK-2 Part #FRPAPK2RF

13.8 Installing the PureAir Produce Keeper Plus™

⚠ CAUTION!

- Do not open:
Contents may irritate eyes or skin. Keep out of reach of children.
- First aid:
Contains potassium permanganate. In case of contact with eyes or skin, rinse immediately with water.
- Do not eat:
If swallowed, seek medical treatment immediately.

1. Remove the plastic wrapper. Insert unopened packet into the holder in the crisper drawer.
2. For optimal results, replace the refill every 12 months along with your air filter.

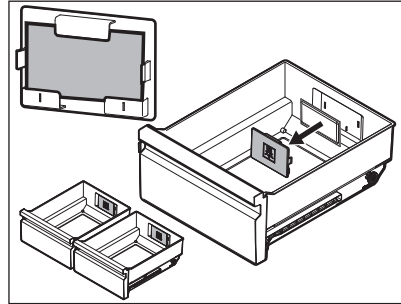

14. CARE AND CLEANING

14.1 Protecting your investment

Keeping your appliance clean maintains its appearance and prevents odor build-up. Wipe up any spills immediately and clean the freezer and fresh food compartments at least twice a year. When cleaning, take the following precautions:

- Never use metallic scouring pads, brushes, abrasive cleaners, or strong alkaline solutions on any surface.
- Never use chloride or cleaners with bleach to clean stainless steel.
- Do not wash any removable parts in a dishwasher.
- Always unplug the electrical power cord from the wall outlet before cleaning.
- Do not remove the serial plate.
Removal of your serial plate voids your warranty.
- Remove adhesive labels by hand. Do not use razor blades or other sharp instruments which can scratch the appliance surface.
- Before moving your appliance, raise the anti-tip brackets so the rollers will

work correctly. This will prevent the floor from being damaged.

Do not use abrasive cleaners such as window sprays, scouring cleansers, brushes, flammable fluids, cleaning waxes, concentrated detergents, bleaches or cleansers containing petroleum products on plastic parts, interior doors, gaskets or cabinet liners. Do not use paper towels, metallic scouring pads, or other abrasive cleaning materials or strong alkaline solutions.

Refer to the guide below for more details on caring and cleaning specific areas of your appliance.

🔪 NOTE

If you set your temperature controls to turn off cooling, power to lights and other electrical components will continue until you unplug the power cord from the wall outlet.

CAUTION!

Pull the appliance straight out to move it. Shifting it from side to side may damage flooring.

Be careful not to move the appliance beyond the plumbing connections.

CAUTION!

Damp objects stick to cold metal surfaces. Do not touch refrigerated surfaces with wet or damp hands.

IMPORTANT

If you store or move your appliance in freezing temperatures, be sure to completely drain the water supply system. Failure to do so could result in water leaks when the appliance is put back into service. Contact a service representative to perform this operation.

14.2 Vacation and moving tips

Occasion	Tips
Short vacations	<ul style="list-style-type: none">• Leave the appliance operating during vacations of three weeks or less.• Use all perishable items from the appliance compartment.• Turn automatic ice maker off and empty ice bucket, even if you will only be gone a few days.
Long vacations	<ul style="list-style-type: none">• Remove all food and ice if you will be gone one month or more.• Turn the cooling system off and disconnect power cord. Refer to Controls and Settings• Turn water supply valve to closed position.• Clean interior thoroughly.• Leave both doors open to prevent odors and mold build-up. Block doors open if necessary.
Moving	<ul style="list-style-type: none">• Unplug the appliance• Remove all food and ice.• Recommend use of a handcart, load from the side.• Adjust rollers all the way up to protect them during sliding or moving.• Pad cabinet to avoid scratching surface.

14.3 Care & Cleaning Tips

Part	What to use	Tips and precautions
Interior and door liners	<ul style="list-style-type: none">• Soap and water• Baking soda and water	Use 2 tablespoons of baking soda in 1 quart of warm water. Be sure to wring excess water out of sponge or cloth before cleaning around controls, light bulb or any electrical part.
Door gaskets	Soap and water	Wipe gaskets with a clean soft cloth.
Drawers and bins	Soap and water	Use a soft cloth to clean drawer runners and tracks.
Glass shelves	<ul style="list-style-type: none">• Soap and water• Glass cleaner• Mild liquid sprays	Allow glass to warm to room temperature before immersing in warm water.

Part	What to use	Tips and precautions
Exterior and handles	<ul style="list-style-type: none"> • Soap and water • Non abrasive glass cleaner 	Do not use commercial household cleaners containing ammonia, bleach or alcohol to clean handles. Use a soft cloth to clean smooth handles. Do not use a dry cloth to clean smooth doors.
Exterior and handles (Stainless steel models only)	<ul style="list-style-type: none"> • Soap and water • Stainless steel cleaners 	Never use chloride or cleaners with bleach to clean stainless steel. Clean stainless steel front and handles with non-abrasive soapy water and a dishcloth. Rinse with clean water and a soft cloth. Use a non-abrasive stainless steel cleaner. These cleaners can be purchased at most home improvement or major department stores. Always follow manufacturer's instructions. Do not use household cleaners containing ammonia or bleach. Always clean, wipe and dry with the grain to prevent scratching. Wash the rest of the cabinet with warm water and mild liquid detergent. Rinse well, and wipe dry with a clean soft cloth.

15. TROUBLESHOOTING

Let us help you troubleshoot your concern! This section will help you with common issues. If you need us, visit our website, chat with an agent, or call us. We may be able to help you avoid a service visit. If you do need service, we can get that started for you! Visit Frigidaire.com or call toll-free 1-800-374-4432.

Automatic Ice Maker

Concern	Potential Cause	Common solution
Ice maker is not making any ice.	Ice maker is turned off.	Refer to Ice Maker and Controls and Settings. Fresh Food Ice Maker: Press and hold the ice maker button on the appliance control for 3 seconds to turn the ice maker on. The LED indicator illuminates to indicate the ice maker is on. Freezer Ice Maker: Press or slide the power button to turn the ice maker on. The button and LED illuminate when active.
	Refrigerator is not connected to water line or water valve is not open.	Connect the unit to the household water supply and ensure the water valve is open.
	The water supply line is kinked.	Ensure that the supply line does not kink when the refrigerator is pushed into place against the wall.
	The water filter is not seated properly.	Remove and re-install the water filter. Be sure to seat it fully into the locked position.
	The water filter may be clogged with foreign material.	If water dispenses slowly or not at all, or if the filter is 6 months old or older, it should be replaced.

Concern	Potential Cause	Common solution
Ice maker is not making enough ice.	Ice maker is producing less ice than you expect.	
	The water filter may be clogged with foreign material.	If water dispenses slower than normal, or if the filter is six months old or older, it should be replaced.
	Saddle valve on cold water pipe is clogged or restricted by foreign material.	Ensure that the supply line does not kink when the refrigerator is pushed into place against the wall.
	Heavy traffic, opening or closing of the doors excessively.	Turn off household water line valve. Remove valve. Clean valve. Replace valve if necessary.
	Freezer control is set too warm (freezer ice maker).	Set freezer control to colder setting to improve performance of the ice maker (freezer ice maker). Allow 24 hours for temperature to stabilize.
	Water pressure is extremely low. Cut-off and cut-on pressures are too low (well systems only).	Have someone turn up the cut-off and cut-on pressure on the water pump system (well systems only).
Freezer ice maker will not stop making ice (some models).	Reverse osmosis system is in regenerative phase.	It is normal for a reverse osmosis system to be below 20 psi during the regenerative phase.
	Ice maker bail arm is being held down by a package in the freezer that has fallen against ice maker.	Move any item or frozen ice cubes that may block the bail arm from being in the off or upward position.
Ice cubes are freezing together.	Ice cubes are located in once spot inside the freezer ice bin.	Periodically move ice cubes around the ice bin so that ice maker will continue to make ice.
	Ice cubes are not being used frequently enough or interruption of power for prolonged time.	Remove ice container and discard ice. The ice maker will produce fresh supply. Ice should be used at least twice weekly to keep the cubes separated.
	Ice cubes are hollow (shells of ice with water inside). The hollow cubes break open in the bin and leak their water onto existing ice, which causes it to freeze together.	<ul style="list-style-type: none"> • This generally occurs when the ice maker does not get enough water. This is usually the result of a clogged water filter or restricted water supply. • Replace the water filter and if the condition still occurs check for a clogged saddle valve, water valve not turned on all the way or kinked water supply line.

Ice and water dispenser

Concern	Potential cause	Common solution
Dispenser does not dispense ice.	There is no ice in the bin to be dispensed.	See the section above: Ice maker is not making any ice.
	The refrigerator doors are not completely closed.	Completely close the refrigerator doors.
	Dispenser paddle has been pressed too long and the dispenser motor has overheated.	The motor overload protector will reset in about 3 minutes, and then ice can be dispensed.
	Not dispensing ice regularly may melt and re-freeze ice causing ice clumping. Dispensing clumps could damage the ice bucket.	Empty the ice bucket monthly or regularly dispense ice. For longer periods of time (vacation or vacant homes) turn off the ice maker. See tips in Automatic Ice and Water Dispenser.
Ice dispenser is jammed.	Ice has melted and frozen around auger due to infrequent use, temperature fluctuations, and/or power outages.	Remove ice container, thaw, and empty the contents. Clean container, wipe dry, and replace in proper position. When new ice is made, dispenser should operate. See tips on cleaning in Automatic Ice and Water Dispenser.
	Ice cubes are jammed between ice maker and back of ice container.	Remove ice cubes that are jamming the dispenser.
Dispenser does not dispense water.	Water filter not seated properly.	Remove and reinstall the water filter. For PurePour Connect™, be sure to push the filter in all the way until it clicks into place and is secured inside of the water filter housing.
	Water filter is clogged.	Replace filter cartridge. Be sure to push filter all the way in until it clicks into place and is secured inside of the water filter housing.
	Household water line valve is not open.	Open household water line valve.
Water not cold enough.	The water dispensing system is not designed to chill water.	Add ice to cup or container before dispensing water.
Water has an odd taste and/or odor.	Water has not been dispensed for an extended period of time.	Draw and discard 10-12 glasses of water to freshen the supply.
	The appliance not properly connected to cold water line.	Connect the appliance to cold water line that supplies water to the kitchen faucet.

Opening/Closing of Doors/Drawers

Concern	Potential cause	Common solution
Door(s) does not close.	Door was closed too hard, causing other door to open slightly.	Close both doors gently.
	Refrigerator is not level. It rocks on the floor when moved slightly.	Ensure floor is level and solid, and can adequately support the refrigerator. Contact a carpenter to correct a sagging or sloping floor.
	Refrigerator is touching a wall or cabinet.	Ensure floor is level and solid, and can adequately support the refrigerator. Contact a carpenter to correct a sagging or sloping floor.
	Food/package is obstructing the door from closing.	Make sure there is no food/package blocking the doorway.
Drawers are difficult to move.	Food is touching shelf on top of drawer.	Remove top layer of items in drawer.
	Track that drawers slide on is dirty.	<ul style="list-style-type: none"> • Ensure drawer is properly installed on track. • Clean drawer, rollers, and track. Refer to Care and Cleaning.

Running of appliance

Concern	Potential cause	Common solution
Compressor does not run.	The appliance is unplugged.	Ensure plug is tightly pushed into outlet.
	Refrigerator is in defrost cycle.	This is normal for a fully automatic defrost refrigerator. The defrost cycle occurs periodically, lasting about 30 minutes.
	House fuse blown or tripped circuit breaker.	Check/replace fuse with a 15 amp time-delay fuse. Reset circuit breaker.
	Power outage.	Check house lights. Call local electric company.
Refrigerator seems to run too much or too long.	The variable speed compressor is designed to run 100% of the time except during the defrost cycle. At times it will run faster, such as after a defrost cycle.	It is normal for the compressor to run continuously except during defrost mode.
Appliance seems to run continuously.	The appliances are designed with a variable speed compressor to be more energy efficient than previous models. This means your compressor reacts quickly to temperature fluctuations and circulates cold air based off your use and room temperature.	This is normal for a variable speed compressor refrigerator; however, if you have concerns, call toll-free 1-800-374-4432 or visit Frigidaire.com .

Digital temperature display

Concern	Potential cause	Common solution
Digital temperature displays an error.	Electronic control system has detected a performance problem.	Call your Frigidaire service representative, who can interpret any messages or number codes flashing on the digital displays.

Water/Moisture/Frost Inside Refrigerator

Concern	Potential cause	Common solution
Moisture collects on inside of refrigerator walls.	Weather is hot and humid.	The rate of frost buildup and internal sweating increases.
	Flipper mullion	Adjust flipper mullion. Refer to Flipper Mullion in Installation.
	Door is slightly open.	See the Opening/Closing of Doors/Drawers section above.
Water collects on bottom side of drawer cover.	Vegetables contain and give off moisture.	<ul style="list-style-type: none">• It is not unusual to have moisture on the bottom side of the cover.• Move humidity control (some models) to lower setting.
Water collects in bottom of drawer.	Washed vegetables and fruit drain while in the drawer.	Water collecting in bottom of drawer is normal. Dry items before putting them in the drawer or store produce in tightly sealed bags to help reduce condensation inside of the drawer.

Water/Moisture/Frost Outside Refrigerator

Concern	Potential cause	Common solution
Moisture collects on outside of refrigerator or between doors.	Weather is humid.	This is normal in humid weather. When humidity is lower, the moisture should disappear.
	Door is slightly open, causing cold air from inside refrigerator to meet warm air from outside.	See the Opening/Closing of Doors/Drawers section above.

Food in Fresh food compartment

Concern	Potential cause	Common solution
Food is freezing.	Temperature setting is too low.	Move the setting to a higher degree.
	Temperature sensor is covered by food (right side of fresh food area).	Allow space for air flow to the sensor.
	Food is covering the air ports.	Allow space between the air ports and the food.

16. LIMITED WARRANTY

Your appliance is covered by a one year limited warranty. For one year from your date of delivery, Electrolux will pay all costs for repairing or replacing any parts of this appliance that prove to be defective in materials or workmanship when such appliance is installed, used and maintained in accordance with the provided instructions.

Exclusions

This warranty does not cover the following:

1. Products with original serial numbers that have been removed, altered or cannot be readily determined.
2. Product that has been transferred from its original owner to another party or removed outside the USA, Puerto Rico, or Canada.
3. Rust on the interior or exterior of the unit.
4. Products purchased "as-is" are not covered by this warranty.
5. Food loss due to any refrigerator or freezer failures.
6. Products used in a commercial setting.
7. Service calls which do not involve malfunction or defects in materials or workmanship, or for appliances not in ordinary household use or used other than in accordance with the provided instructions.
8. Service calls to correct the installation of your appliance or to instruct you how to use your appliance.
9. Expenses for making the appliance accessible for servicing, such as removal of trim, cupboards, shelves, etc., which are not a part of the appliance when it is shipped from the factory.
10. Service calls to repair or replace appliance light bulbs, air filters, water filters, other consumables, or knobs, handles, or other cosmetic parts.
11. Surcharges including, but not limited to, any after hour, weekend, or holiday service calls, tolls, ferry trip charges, or mileage expense for service calls to remote areas, including the state of Alaska.
12. Damages to the finish of appliance or home incurred during transportation or

installation, including but not limited to floors, cabinets, walls, etc.

13. Damages caused by: services performed by unauthorized service companies; use of parts other than genuine Electrolux parts or parts obtained from persons other than authorized service companies; or external causes such as abuse, misuse, inadequate power supply, accidents, fires, or acts of God.

DISCLAIMER OF IMPLIED WARRANTIES; LIMITATION OF REMEDIES

CUSTOMER'S SOLE AND EXCLUSIVE REMEDY UNDER THIS LIMITED WARRANTY SHALL BE PRODUCT REPAIR OR REPLACEMENT AS PROVIDED HEREIN. CLAIMS BASED ON IMPLIED WARRANTIES, INCLUDING WARRANTIES OF MERCHANTABILITY OR FITNESS FOR A PARTICULAR PURPOSE, ARE LIMITED TO ONE YEAR OR THE SHORTEST PERIOD ALLOWED BY LAW, BUT NOT LESS THAN ONE YEAR. ELECTROLUX SHALL NOT BE LIABLE FOR CONSEQUENTIAL OR INCIDENTAL DAMAGES SUCH AS PROPERTY DAMAGE AND INCIDENTAL EXPENSES RESULTING FROM ANY BREACH OF THIS WRITTEN LIMITED WARRANTY OR ANY IMPLIED WARRANTY. SOME STATES AND PROVINCES DO NOT ALLOW THE EXCLUSION OR LIMITATION OF INCIDENTAL OR CONSEQUENTIAL DAMAGES, OR LIMITATIONS ON THE DURATION OF IMPLIED WARRANTIES, SO THESE LIMITATIONS OR EXCLUSIONS MAY NOT APPLY TO YOU. THIS WRITTEN WARRANTY GIVES YOU SPECIFIC LEGAL RIGHTS. YOU MAY ALSO HAVE OTHER RIGHTS THAT VARY FROM STATE TO STATE.

If You Need Service

Keep your receipt, delivery slip, or some other appropriate payment record to establish the warranty period should service be required. If service is performed, it is in your best interest to obtain and keep all receipts. Service under this warranty must be obtained by

contacting Electrolux at the addresses or phone numbers below.

This warranty only applies in the USA, Puerto Rico and Canada. In the USA and Puerto Rico, your appliance is warranted by Electrolux Consumer Products, Inc. In Canada, your appliance is warranted by Electrolux Canada Corp. Electrolux authorizes no person to change or add to any obligations under this warranty. Obligations for service and parts under this warranty must be performed by Electrolux or an authorized service company. Product features or specifications as described or illustrated are subject to change without notice.

USA

1-800-374-4432

Electrolux Consumer Products, Inc.

10200 David Taylor Drive

Charlotte, NC 28262

Canada

1-800-265-8352

Electrolux Canada Corp.

5855 Terry Fox Way

Mississauga, Ontario, Canada L5V 3E4

17. QUEBEC RIGHT TO REPAIR

Though Frigidaire makes every effort to make replacement parts, repair services and information necessary to maintain or repair our products available to consumers, parts, service and information are not guaranteed, pursuant to section 39 of the Consumer Protection Act, CQLR, c. P-40.1 and sections 79.18 to 79.20 of the Regulation respecting the application of the Consumer Protection Act, CQLR, c. P-40.1, r. 3. If you need replacement parts, you may call us at 1 (800) 265-8352 for service in French or English, or purchase online at **Frigidaire Parts | Shop Frigidaire Replacement Parts & Accessories - Frigidaire Appliance Parts.**

You may book repair services online at <https://www.frigidaire.ca/RIGHT-TO-REPAIR/>. Alternatively, our resource library is available at **Resource Library | Frigidaire** to help you diagnose and resolve issues which may arise during the lifetime of your appliance.

Though most parts are available for purchase, subject to short-term availability constraints, the following appliances and parts are not serviceable.

Legend

Availability of replacement parts, repair services, and information for maintenance or repair.



Partially Available



Not Available



Available

Refrigerators



Cabinet, 14cu ft and less no sealed system parts

Freezer



9 cu. ft and less no sealed system parts.

Beverage Centers



Only cosmetic parts available

A series of 20 horizontal dotted lines for writing.

A series of 20 horizontal dotted lines for writing.

