

# Flexmaster Overshelf For Hot Food Tables

## ASSEMBLY INSTRUCTIONS

### CAUTION

INSPECT CONTENTS IMMEDIATELY AND FILE CLAIM WITH DELIVERING CARRIER FOR ANY DAMAGE.

**SAVE YOUR BOX AND ALL PACKING MATERIALS.**

YOU ARE RESPONSIBLE FOR DAMAGE TO YOUR UNIT IF RETURNED IMPROPERLY PACKED.

### Parts Listings

#### 4-Post Kit

- Four (4) - Post (18", 30", or 48" height)
- Two (2) - Mounting Angles

#### 6-Post Kit

- Six (6) - Posts (18", 30" or 48" height)
- Two (2) - Mounting Angles
- One (1) - Mounting Plate

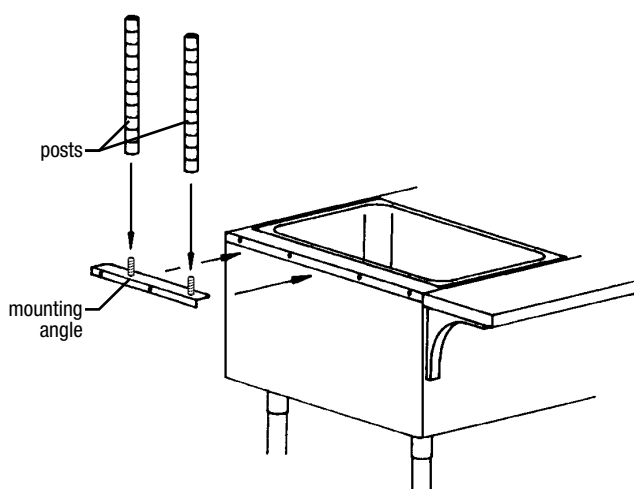

Figure 1

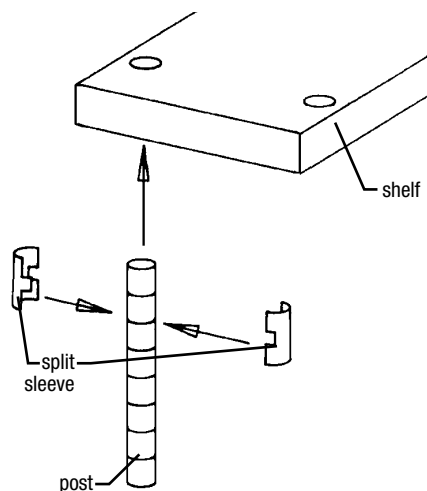

Figure 2

### 1 Mounting Plates

Remove 2 screws on end of table that secures top to side. Place the mounting angles on edge of tabletop and replace screws through angles and into table. Repeat on other side. Once the mounting angles are secure, screw posts to mounting angles. Hand tighten. Refer to *Figure 1*.

### 2 First Shelf

Referencing numbers on posts, snap plastic tapered split sleeves onto each post at desired location for shelf. Refer to *Figure 2*. The thicker part of the taper goes towards the bottom. Make sure the rib on the split sleeve is seated into the groove at the selected height. Place the first shelf over the posts until the split sleeves are seated snugly within the collars.

### 3 Additional Shelves

Snap split sleeves onto posts at the desired location for the second shelf. Lower shelf onto posts until split sleeves are snugly seated with corner collars. Repeat for additional shelves. Securely seat all shelves by placing a board across the corners of the shelves and gently tapping with a hammer. Shelf assembly is now ready for use.

EG9835 Revised 05/23



• 100 Industrial Boulevard, Clayton, Delaware 19938-8903 U.S.A.  
• Phone: 302/653-3000 • 800/441-8440 • Fax: 302/653-2065  
• www.eaglegrp.com • www.eaglegrpnews.com • www.eaglemhc.com

Eagle Foodservice Equipment, Eagle MHC, and SpecFAB® are divisions of Eagle Group. ©2023 by the Eagle Group