

MPPT Solar Charge Controller



User Manual

Guangdong Xindun Power Technology Co., Ltd

Guangdong Xindun Power Technology Co., Ltd

Web: www.xinduninverter.com



Official Website

Content

1. Description and Product Features -----	1
2. Description of System -----	2
3. Safety information -----	2
4. Connection and Application -----	2
5. Description of Panel -----	4
6. Application Instruction-----	4
7. Specification-----	12
8. Protection and Troubleshooting -----	13
9. Installation-----	15
10. Appendix: 485 Communication Port-----	16
11. Appendix(Maintenance Record&Certificate)-----	17



Warning

This is A class inverter. It might cause slightly radio interference in daily life. And practical measure is required to take under this condition.

1. Description and Product Features

Thank you for choosing MPPT solar charge controller. Based on advanced MPPT algorithm design, the controller adopts graphical LCD dynamic display to present its running status. With the MPPT algorithm, the controller can quickly track the maximum power point of the PV array; Promptly acquire the maximum energy of solar modules to improve power generation. Users are access to extended application with the adoption of standard modbus RS485 communication port.

Product Features:



- Advanced MPPT tracking technology ,increase power generation;
- With 12V/24V battery system setting function;
- With lithium battery activation function;
- With battery temperature compensation function;
- Multiple load working modes: pure light control, light control + timing, general mode, normally open mode;
- Scientific battery management method, three-stage charging: fast charging, boost/balance, floating charge, which greatly prolongs the service life of the battery;
- The LCD display visually displays the operating data and working status of the photovoltaic array, battery and load;
- The LCD displays the adjustment parameters, allowing users to understand the system's operating status in real time, and has rich parameter settings. Users can set corresponding working modes according to different usage environments;
- With overcharge, over discharge, overload protection, controller over temperature protection and unique electronic short circuit protection, all protections will not damage any parts piece, no insurance;
- With LCD display, all settings can be completed by simple button operation, which is convenient and intuitive to use.

2. Description of System

The controller is designed for solar DC power supply system, solar DC streetlamp system, and small solar power plant system by adopting special- purpose microprocessor to achieve intelligent control.

In addition, the controller protects systems from short circuit, overload, and reverse connection. And it shuts down (charged-full or overcharged) and recovers automatically based on the condition of battery. It also provides detailed indication of charging and errors, and shows the state of battery and loads. It realizes the control of battery by collecting and calculating data of battery and PV allay voltage, discharging and charging current as well as temperature of environment. Life of battery is greatly prolonged by three-stage charging control, which makes sure of the best working state of battery, Also, various needs can be fulfilled by the multiple working modes of controller.

3. Safety information

 	<p>CAUTION!</p> <p>Risk of electric shock. Each circuit must be individually disconnected and the service person must wait 5 minutes before servicing.</p>
---	---

4. Connection and Application

- 1) The controller should be installed firmly as close as possible to the battery.
- 2) Cable: please use cables matching with the charging current. Calculate the length and strip about 5mm length of insulated leather and connect the wire to the controller. The cable is supposed to be as short as it can to make sure of less wastage. The system cable is selected for the density of current ($\leq 5A/mm^2$).
- 3) Connect the battery: Determine the appropriate number of batteries according to the controller's rated battery voltage. Connect the battery cable to a circuit breaker that meets the breaking capacity, and then connect it to the BATTERY terminal of the controller. Please note that the positive and negative poles are not allowed. Reverse connection, otherwise the product may be damaged. If the connection is correct, the LCD display will light up and display the relevant status parameters, otherwise, you need to check whether the connection is correct.
- 4) Connect the solar panels: first connect the PV cable to a circuit breaker that meets the breaking capacity, and then connect it to the PV terminal of the controller. Please note that the positive and negative poles can not be reversed, otherwise the product may be damaged. If the connection is correct, when there is sunlight, the LCD display will display the relevant status parameters, otherwise, you need to check whether the connection is correct.
- 5) Connection of loads: connect load to the output of controller. Please connect the negative and positive poles are connected correctly.
- 6) Do not connect the inverter or other load with large inrush current to the DC load output of this controller. Connect the inverter directly to the battery.
- 7) Selection of circuit breaker
 - a. The circuit breakers on the PV side and the battery side should use DC circuit breakers, and the working voltage of the circuit breaker should be greater than the actual application voltage.
 - b. When the controller is working, the rated current of the circuit breaker should be approximately 1.5 times the maximum current.
- 8) Controller entry and exit line illustration:

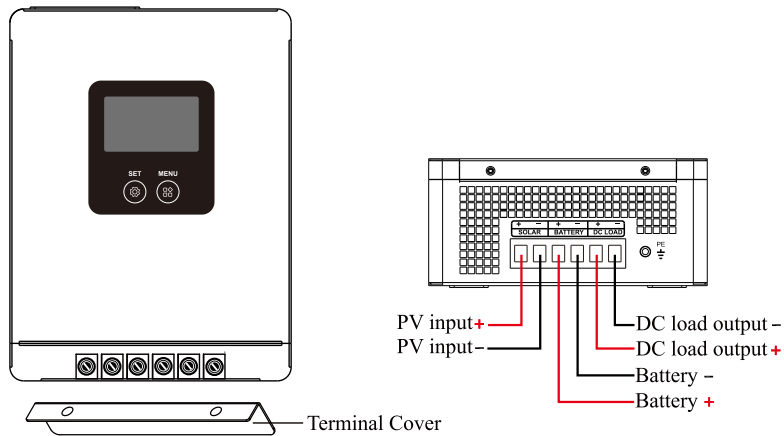

① Remove the terminal cover

② Connect solar panels, batteries and DC loads in the order indicated above

9) Wiring diagram:

(Remarks: Please refer to the technical parameter table for specific battery voltage and solar panel parameter. This diagram is only for wiring diagram. 12V system: 1 unit 12V battery; 24V system: 2 units 12V battery connect in series; 48V system: 4 units 12V battery connect in series.)

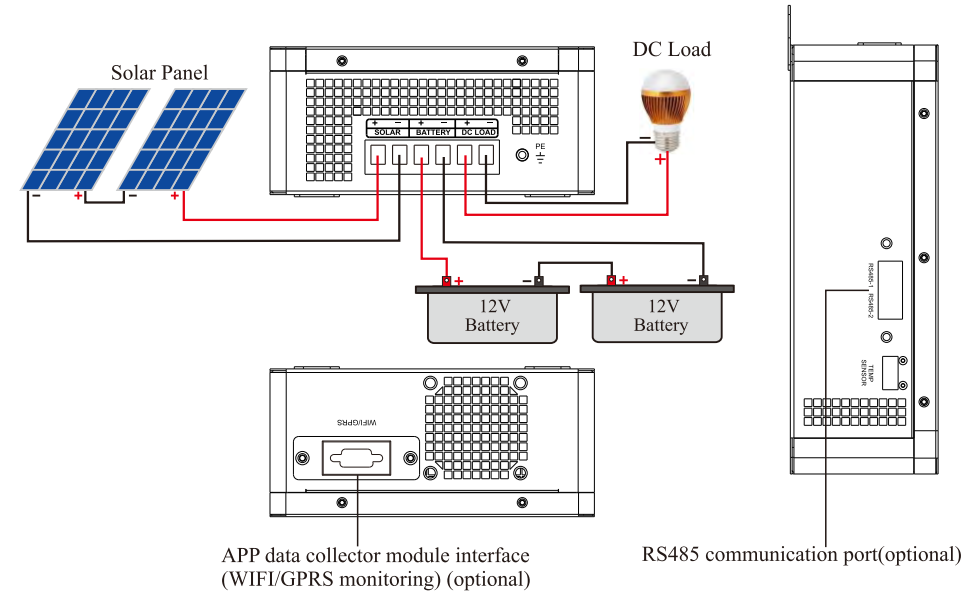

Note:

- The installation of the solar system components should be followed by battery--load--PV array;
- Please do not open the air switch or fuse during the connection, and make sure that the positive and negative poles of the parts are connected correctly;
- Sequence of disconnection is as follow: PV array--load--battery.

5. Description of Panel

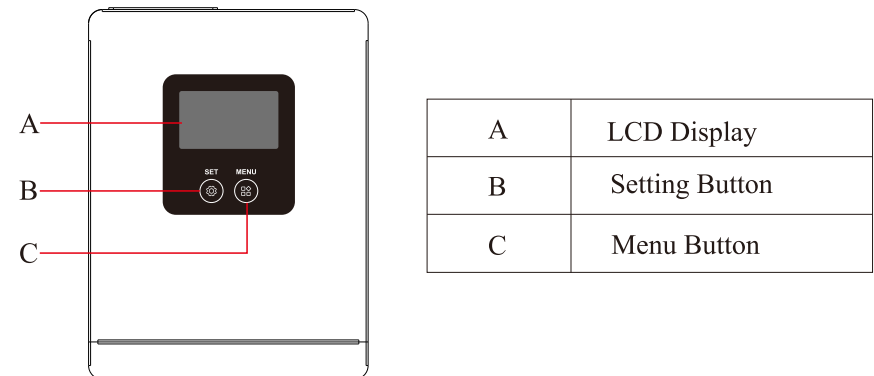

6. Application Instruction

1) Button and operation

Mode	Remark
Loads switch	When the load is set to general mode, press the menu key (MENU) to turn on or off the load
Browse mode	Press the SET key (SET) on the main display interface to view relevant operating data
Setting mode	In the state of the battery voltage display interface, press and hold the SET button (SET) to enter the setting mode

2) Main Interface

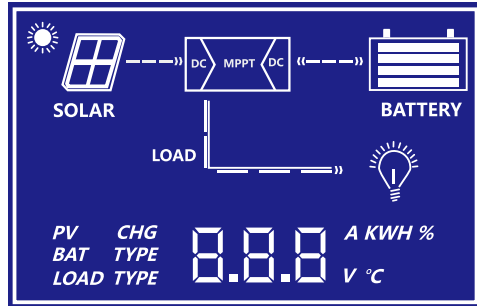

3) Description of State

Item	Icon	State
PV array		Day/sunshine
		Night/no sunshine
Battery		Power and voltage
		Over-discharge
Load		Turn on
		Shut down

4) Interface

Press the SET key (SET) on the main display interface to view relevant operating data

Display	Description	Display	Description
	Battery voltage		PV input voltage
	Charging current		The current of the loads
	Battery capacity percentage		PV power generation
	Number of batteries		Battery protocol selection
	Type of loads		The heat sink temperature of the controller
	The heat sink temperature of the controller		The rated charge and discharge current of the controller
	Controller communication address		

5) Setting modes Introduction

In the state of the battery voltage display interface, press and hold the SET button (SET) for 2 seconds to enter the setting mode. Press the menu key (MENU) for 1 second to select the setting item to be changed (there are 9 parameters that can be set in total, and the codes are 000 - 008). When the setting item is selected, press the SET button (SET) for 1 second again to enter the function parameter setting of this item. Press the SET button (SET) to decrease the value, and press the MENU button, the value is incremented. When the parameter is set, press and hold the SET button (SET) for 2 seconds to exit the setting mode. After the parameter is set, power on again to take effect.

1. The operation guide for the home screen to enter the function parameter setting screen

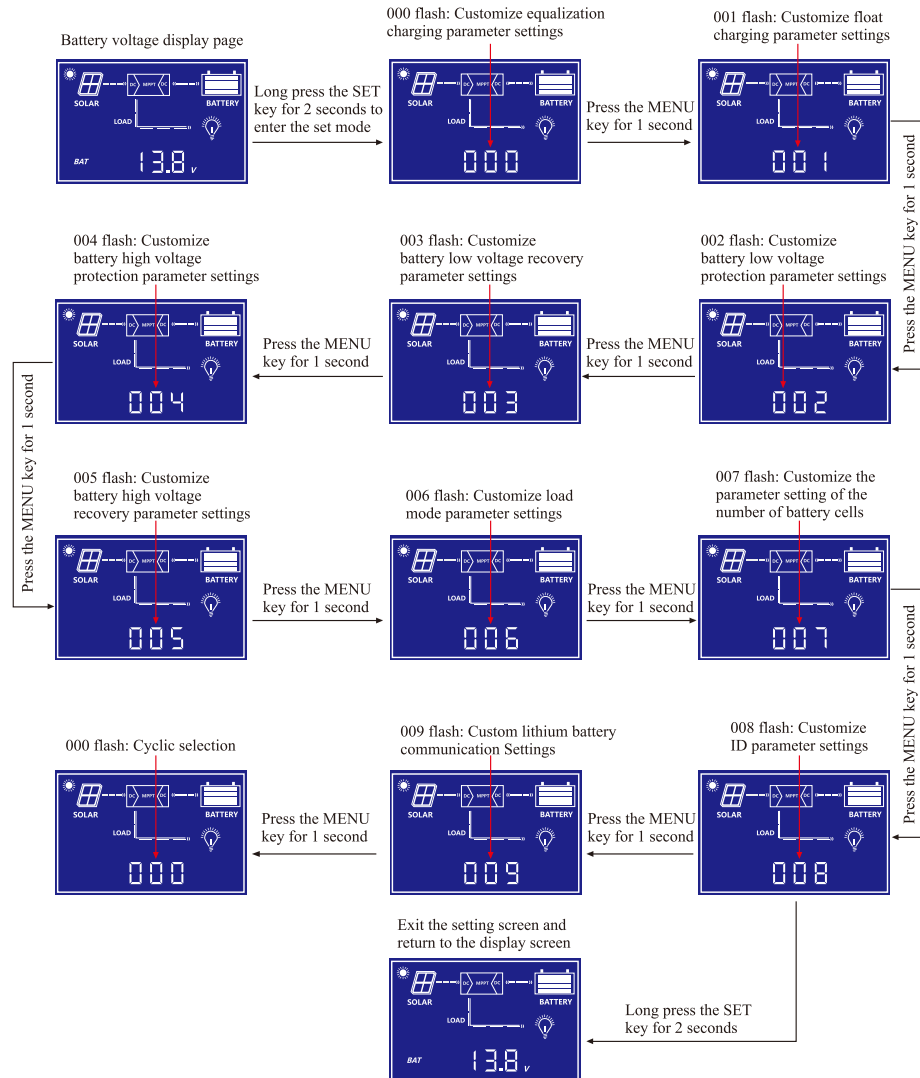

2. The operation guide for the parameter settings in the function settings screen

000) Customize equalization charging parameter settings

When the 000 option in the setting menu is flashing, press the SET button (SET) for 1 second, the word BAT CHG will flash, and then you can enter the function parameter to set parameter, press the SET button (SET) to decrement the value, When the menu key (MENU) is lightly pressed, the value is incremented. For example, the required charging voltage is 14.2V, that is, press the menu key and the set key to 14.2V, after selection, press and hold the set key (SET) to exit. (Settable range: 12V system: 12.0V~15.5V; 24V system: 24.0V~31.0V, 48V system: 48.0V~62.0V).

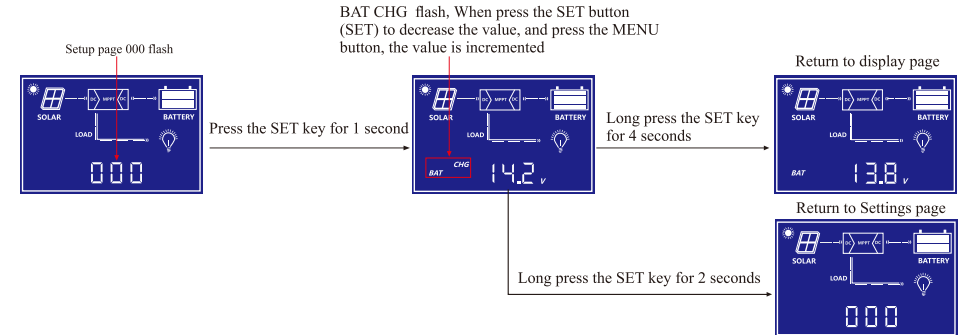

001) Customize float charging parameter settings

When the selected option 001 in the setting menu is flashing, press the SET button (SET) for 1 second, and the word BAT CHG will flash, and then you can enter the function parameter setting of this item. Press the SET button (SET) to decrement the value. When the menu key (MENU) is lightly pressed, the value is incremented. For example, the required charging voltage is 13.8V, that is, press the menu key and the set key to 13.8V, after selection, long press the set key (SET) to exit. (Settable range: 12V system: 12.0V~15.5V; 24V system : 24.0V~31.0V; 48V system: 48.0V~62V).

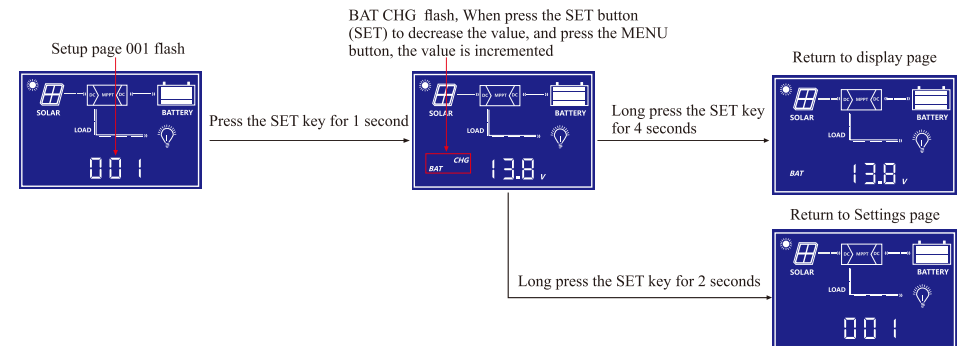

002) Customize battery low voltage protection parameter settings

When the selected option 002 in the setting menu is flashing, press the SET button (SET) for 1 second, and the word BAT CHG will flash, and then you can enter the function parameter setting of this item. Press the SET button (SET) to decrement the value. When the menu key (MENU) is lightly pressed, the value is incremented. For example, the required low voltage of the battery is 10.5V, that is, press the menu button and the set button to 10.5V, after selection, press and hold the set button (SET) to exit. (Settable range: 12V system: 7.0V~13.0V; 24V system: 14.0V~26.0V; 48V system: 28.0V~52.0V).

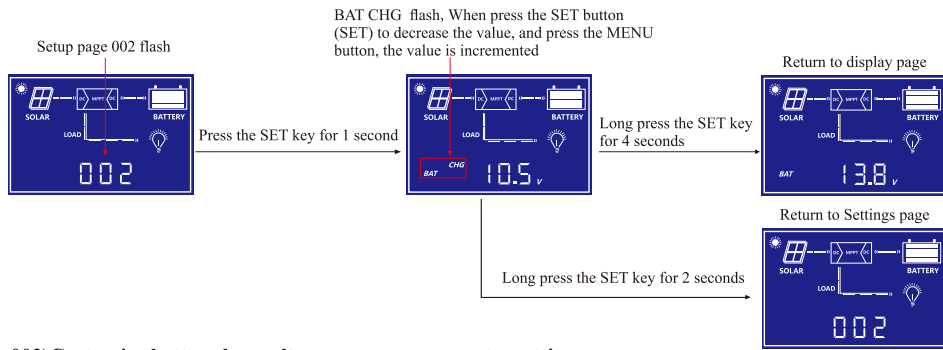

003)Customize battery low voltage recovery parameter settings

When the selected option 003 in the setting menu is flashing, press the SET button (SET) for 1 second, and the word BAT CHG will flash, and then you can enter the function parameter setting of this item. Press the SET button (SET) to decrease the value. When the menu key (MENU) is lightly pressed, the value is incremented. For example, the low voltage of the battery needs to be restored to 12.5V, that is, press the menu key and the set key to 12.5V, after selection, press and hold the set key (SET) to exit. (Settable range: 12V system: 8.0V~14.0V; 24V system: 16.0V~28.0V; 48V system: 32.0V~56.0V).

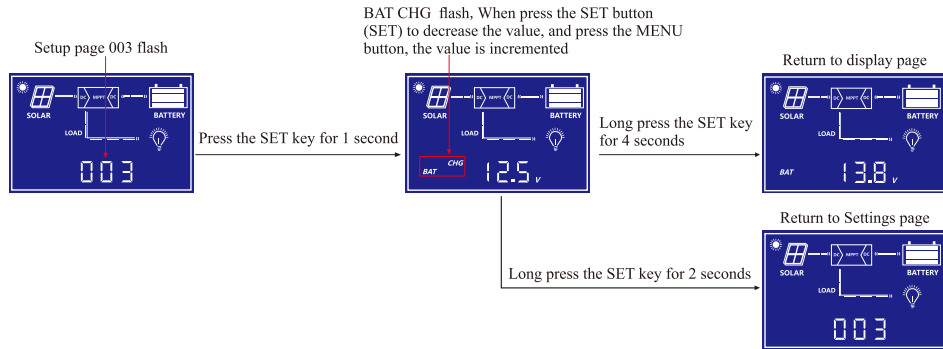

004)Customize battery high voltage protection parameter settings

When option 004 is selected in the setting menu and is flashing, press the SET button (SET) for 1 second, and the word BAT CHG will flash, and then you can enter the function parameter setting of this item. Press the SET button (SET) to decrease the value. When the menu key (MENU) is lightly pressed, the value is incremented. For example, the required battery high voltage protection is 15.5V, that is, press the menu key and the set key to 15.5V, after selection, long press the set key (SET) to exit. (Settable range: 12V system: 13.0V~17.0V; 24V system: 26.0V~34.0V; 48V system: 52.0V~68.0V).

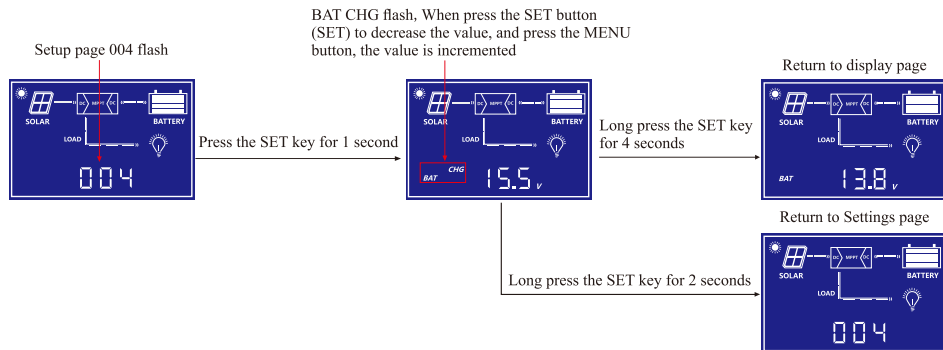

005) Customize battery high voltage recovery parameter settings.

When the selected option 005 in the setting menu is flashing, press the SET button (SET) for 1 second, and the word BAT CHG will flash, and then you can enter the function parameter setting of this item. Press the SET button (SET) to decrease the value. When the menu key (MENU) is lightly pressed, the value is incremented. For example, the high voltage of the battery needs to be restored to 14.5V, that is, press the menu button and the set button to 14.5V, after selection, press and hold the set button (SET) to exit. Re-power on to take effect (settable range: 12V system: 12.0V~16.5V; 24V system: 24.0V~33.0V; 48V system: 48.0V~66.0V).

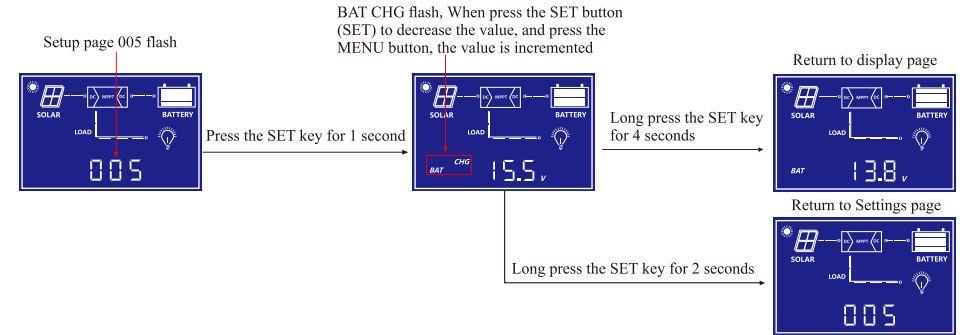

006) Customize load mode parameter settings

When the option 006 is selected in the setting menu and is flashing, press the SET button (SET) for 1 second, and the word LOAD TYPE will flash, and then you can enter the function parameter setting of this item. Press the SET button (SET) to decrease the value. When the menu key (MENU) is lightly pressed, the value is incremented. For example, When the required load mode is 001, press the menu key and the set key to 001, after selection, press and hold the set key (SET) to exit.

100 Pure light control: When there is no sunlight, the light intensity drops to the start point, the controller delays for 10 minutes to confirm the start signal, and then turns on the load according to the set parameters, and the load starts to work; when there is sunlight, the light intensity rises to the start point, The load stops working.

101~115 Light control and time control: The start-up process is the same as that of pure light control. When the load works to the set time, it will automatically shut down, and the set time is 1-15 hours.

001 General mode (default): In this mode, user can control the loads on and off through the panel buttons, no matter whether it is day or night, this mode is used for some special load occasions or for debugging.

000 Normally open mode: In this mode, the load switch is always kept on (the battery voltage is within the range).

The code for the load pattern is as follows:

Code	Mode
100	light control mode
101	Light control turns on the load and turns off the load after 1 hour
102	Light control turns on the load and turns off the load after 2 hour
103-113	Light control turns on the load, and turns off the load after 3-13 hours
114	Light control turns on the load and turns off the load after 14 hours
115	Light control turns on the load and turns off the load after 15 hours
001	General mode(default)
000	Normally open mode

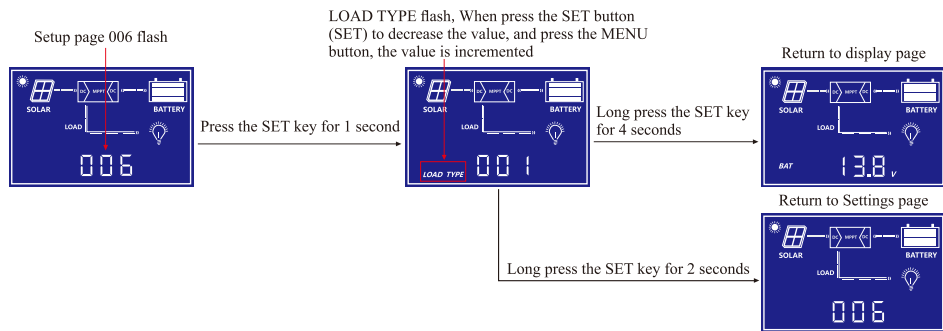

007) Customize the parameter setting of the number of battery cells

When the option 007 is selected in the setting menu and is flashing, press the SET button (SET) for 1 second, and the word BAT will flash, and then you can enter the function parameter setting of this item. Press the SET button (SET) to decrease the value. When the menu key (MENU) is lightly pressed, the value is incremented. For example, the required 12V battery system, that is, by pressing the menu key or the set key to 001, after selection, long press the set key (SET) to exit. The code for the number of battery cells is as follows:

Code	Battery voltage	Code	Battery voltage
001	12V	002	24V

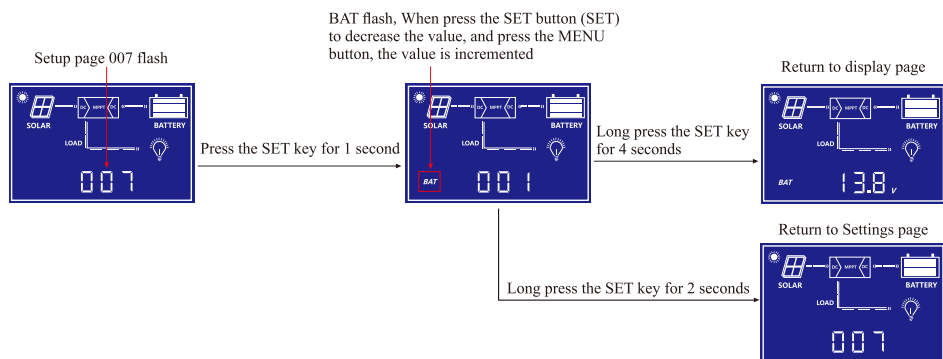

008) Customize ID parameter settings

When option 008 in the setting menu is flashing, press the SET button (SET) for 1 second, and then you can enter the function parameter setting of this item. Press the SET button (SET) to decrease the value, and press the MENU button (MENU) When the value is incremented. For example, when the desired ID is 001, press the menu key or set key to 001, after selection, long press the set key (SET) to exit. (Settable range: 001~250).

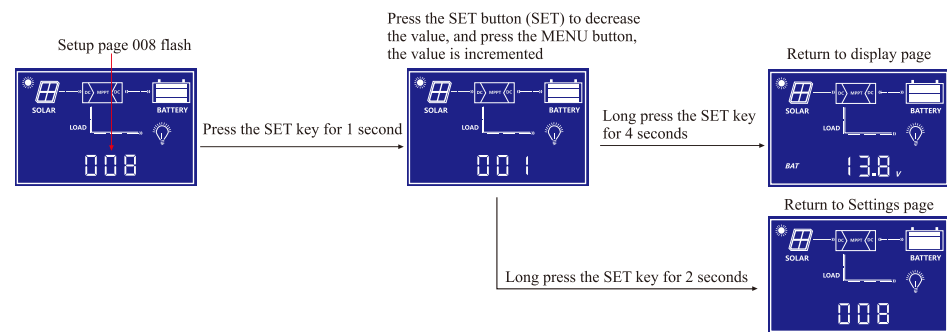

009) Custom lithium battery communication Settings

When the option 009 is selected in the setting menu and is flashing, press the SET button (SET) for 1 second, and the word BAT TYPE will flash, and then you can enter the function parameter setting of this item. Press the SET button (SET) to decrease the value. When the menu key (MENU) is lightly pressed, the value is incremented. For example, if the lead-acid battery is 000, press the menu key and the setting key to 000, after selection, long press the set key (SET) to exit.

The code for the battery protocol is as follows:

Code	Battery protocol	Code	Battery protocol
000	Lead-acid battery(No communication)	001	(GROWATT) lithium battery
002	(Voltronic) lithium battery	003	(PYLONTECH -1) lithium battery
004	(PACEEX) lithium battery	005	(PYLONTECH -2) lithium battery

Note: The BMS Module ID of the controller communicates with 001 address by default, and the lithium battery ID must also be set to 001 address. Otherwise, the addresses do not correspond, and the communication cannot proceed.

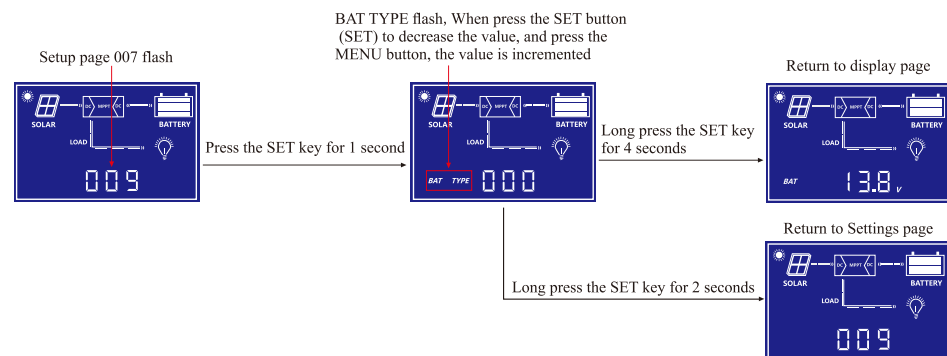

7. Specification

Model: Wonder2	10124, 20124, 30124	1048, 2048, 3048	40124, 50124, 60124	4048, 5048, 6048	80124, 100124	8048, 10048
Rated Current	10A/20A/30A		40A/50A/60A		80A/100A	
Rated System Voltage	12V/24V	48V	12V/24V	48V	12V/24V	48V
Max PV Input Voltage (At the lowest ambient temperature)	120V	180V	120V	180V	120V	180V
MPPT Tracking Voltage Range	12V system: 15V-80V; 24V system: 30V-100V; 48V system: 60V-140V					
Recommended operating voltage range	12V system: 15V-30V; 24V system: 30V-60V; 48V system: 60V-90V					
PV array Max power	12V system: 140W(10A)/280W(20A)/420W(30A)/560W(40A)/700W(50A)/840W(60A)/1120W(80A)/1400W(100A); 24V system: 280W(10A)/560W(20A)/840W(30A)/1120W(40A)/1400W(50A)/1680W(60A)/2240W(80A)/2800W(100A); 48V system: 560W(10A)/1120W(20A)/1680W(30A)/2240W(40A)/2800W(50A)/3360W(60A)/4480W(80A)/5600W(100A)					
Battery Type	Lead acid battery/Lithium battery(Users can customize charging parameters for other types of batteries)					
Floating Voltage	12V system: 13.8V; 24V system: 27.6V; 48V system: 55.2V					
Charge Voltage	12V system: 14.2V; 24V system: 28.4V; 48V system: 56.8V					
Charging Protection Voltage	12V system: 15.5V; 24V system: 31.0V; 48V system: 62.0V					
Increase Protection Voltage	12V system: 14.5V; 24V system: 29.0V; 48V system: 58.0V					
Low Voltage Recovery Point	12V system: 12.5V; 24V system: 25.0V; 48V system: 50.0V					
Discharge Limiting Voltage	12V system: 10.5V; 24V system: 21.0V; 48V system: 42.0V					
Temperature Compensation Coefficient	-3mV / °C / 2V (25°C is base line) (Optional)					
Charging Mode	MPPT maximum power point tracking					
Charging Method	Three stages: constant current(MPPT); constant voltage; floating charge					
Protection	Over-voltage/under-voltage/over-temperature/Anti-reverse connection protection					
Conversion Efficiency	>98%					
MPPT Tracking Efficiency	>99%					
Machine Size(L*W*Hmm)	214x155x72.8		238x180x82		315x210x106.5	
Package Size (L*W*Hmm)	243x184x115(1pc) 497x379x247(8pcs)		267x209x124(1pc) 639x278x265(6pcs)		344x239x149(1pc) 489x355x315(4pcs)	
N.W(kg)	1.6(1pc)		2.4(1pc)		4.2(1pc)	
G.W.(kg)	1.8(1pc)		2.7(1pc)		4.6(1pc)	
System Parameter						
Display	LCD					
Thermal Method	Cooling fan in intelligent control					
Type Of Mechanical Protection	IP20					
Operating Temperature	-15°C~+50°C					
Storage Temperature	-20°C~+60°C					
Elevation	2000m(Dreating above 2000m)					
Humidity	5%~95%(No condensation)					
Communication(Optional)	RS485/APP(WIFI monitoring or GPRS monitoring)					

Note: All specification is subject to change without prior notice

8. Protection and Troubleshooting

7-1: Protection

【PV array over-current】

If it exceeds the rated power of the controller, the controller will charge at rated power. Therefore when the PV array does not match the parameters, it may not work on the maximum power.

【PV array polarity reversal】

When the polarity of the PV array is reversed, the controller will not be damaged and the controller still works properly after wiring properly.

【Battery over-voltage】

When battery voltage reaches the over-voltage, the controller will automatically stop charging the battery to prevent the battery from overcharging and damage.

【Battery over discharge】

When battery voltage reaches the low voltage, the controller will automatically stop the battery discharge, to prevent the battery over discharge and damage.

【Battery over-temperature】

The controller detects the battery temperature through an external temperature sensor. When the battery temperature exceeds 65°C will stop working, less than 55°C to resume work.

【Load overload】

If the load current exceeds 1.2 times the rated current of the controller, the controller will turn off the load. When the overload occurs, you can reduce the electrical equipment and then press the menu button to turn on the load output again.

【Short circuit】

When the load side of the short circuit (≥ 2 times the rated current), the controller will automatically protect.

【Controller over-temperature】

The controller detects the internal temperature of the controller through the internal sensor. When the internal temperature exceeds 90°C will stop working, less than 75°C to resume work.

【Temperature sensor damage】

When the temperature sensor is short-circuited or damaged or is not connected, the controller will charge or discharge at 25°C by default to prevent overcharging or over-discharge of the battery.

【High voltage surge protection】

This product can protect high-voltage surges with low energy. In areas with frequent lightning, it is recommended to install large-capacity lightning arresters on the PV input terminals.

8-2: Troubleshooting

Code for alarm





Warning Code	Reason	Solution
A01	Over temperature protection	Please check whether the configuration of the photovoltaic array is too large, whether the ventilation holes of the controller chassis are blocked, and whether the cooling fan is faulty.
A02	Battery high voltage protection	Please check whether the number of battery cells in the controller is set incorrectly and whether the battery voltage is normal
A03	BUS high voltage	Wait for a period of time, if it cannot be restored, please contact the supplier
A04	BUS low voltage	Please contact the supplier
A05	DC output short circuit protection	Please check whether the user equipment is short-circuited or the starting current is too large
A11	DC output overload warning/protection	Please lighten the load
A14	Battery low voltage protection	Please turn off the electrical load, charge the battery, and restart the machine
A15	PV input high voltage	Please check whether the PV array voltage exceeds the controller specification requirements
A16	NTC failure	Please check whether the NTC temperature sensor is in poor contact
A19	Incorrect setting parameters	Please check whether the battery parameters are set correctly
A21	Lithium battery communication failure	Please check whether the communication cables between the controller and the lithium battery are properly connected and correspond to the manufacturer's agreement or ID

Note:

when setting voltage parameters, the following conditions shall be met, otherwise the controller will report A19 fault.

- 1). Voltage value: Battery high voltage > Battery high voltage recovery;
- 2). Voltage value: Battery high voltage \geq Battery equalizing voltage;
- 3). Voltage value: Battery equalizing voltage \geq Battery floating charge voltage;
- 4). Voltage value: Battery floating charge voltage > Battery low voltage recovery voltage;
- 5). Voltage value: Battery high voltage recovery > Low-voltage battery recovery;
- 6). Voltage value: Low-voltage battery recovery > Battery low;
- 7). If the controller keeps alarming A19 and cannot be used normally, the machine can be restarted manually as well not save the setting data and restore the factory default value (if the parameter setting is correct, i.e. no A19 fault report, the controller will automatically save the data).

Common troubleshooting

Problem	Possible cause	Solutions
Normal wiring but LCD is off	Battery voltage too low	Charge battery
 A02	Battery over-voltage	Disconnect solar arrays and use multi-meter to check battery voltage
 A14	Battery over-discharged	Controller turn off the output automatically and restore
 A11	Over load	Disconnect some loads
 A05	Short circuit	Check the output connection

9. Installation

1) Allow 150mm space around the equipment to make the air circulating.

(Only suitable for installation on concrete or other non-combustible surfaces)

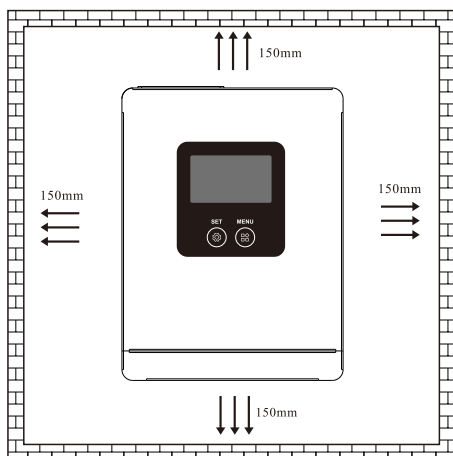

2) Installation size

a. 10A/20A/30A Series

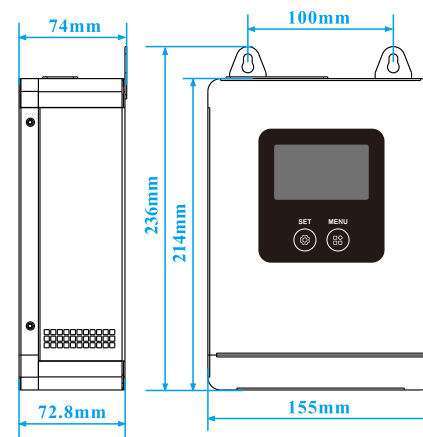

b. 40A/50A/60A Series

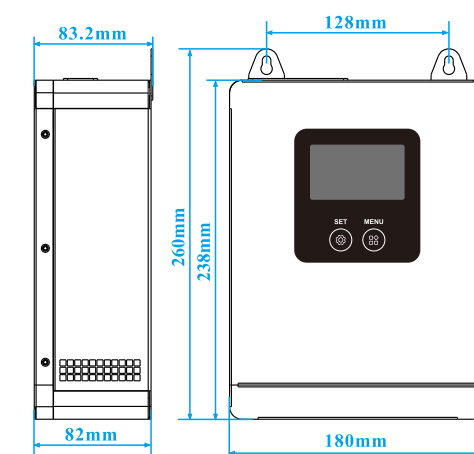

c. 80A/100A Series

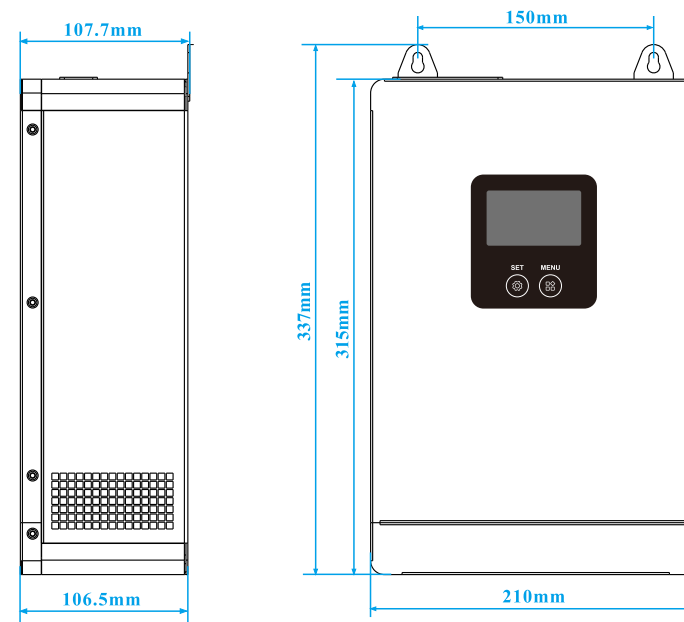

3) Wall mounted installation

a. Fix the wall Pendant on the solar inverter with M4*6 screws (the wall pendant and screws included in the package)

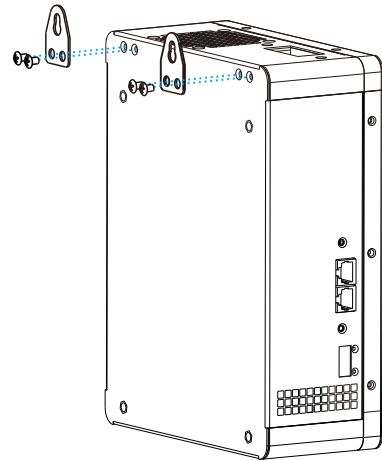

b. Tighten two screws to install the inverter, it is recommended to use M6 expansion screws (the screws need to be purchased by the user. Please refer to the mark on the machine size drawing for the distance between mounting holes.)

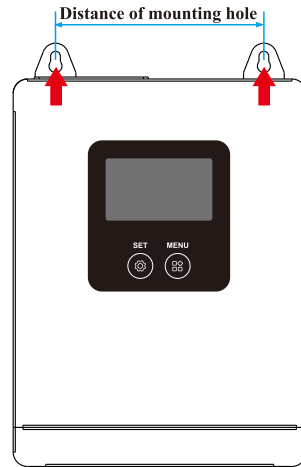

10. Appendix: 485 Communication Port(Optional)

Definition of pin

PIN1-----RS485-B	
PIN2-----RS485-A	
PIN3-----NC	
PIN4-----GND	
PIN5-----NC	
PIN6-----NC	
PIN7-----NC	
PIN8-----NC	

NC: Refer to as not connect.

Warranty Card

Customer Name: _____ Tel.: _____

Address: _____

Brand: _____ Model: _____

Serial No.: _____ Date of Purchase: _____

Bought From: _____

Invoice Number: _____ Invoice Price: _____

Warranty Instruction

- Please keep this warranty card as proof of maintenance.
- The warranty period is 1 year from the date of purchase.
- During the warranty period, under the condition of normal use and maintenance, if damage caused by the product's own quality, the company will provide free repair and replacement parts after verification.
- The company reserves the right to maintain and interpret all contents.

Free maintain won't be given under the following circumstance:

- The damage caused by the manipulation that hasn't follow the requests of the manual.
- The product has been repaired, modified by technicians other than our company's, and any internal parts of the product have been replaced by users.
- The product number has been altered or product is inconsistent with the warranty card.
- Damage caused by careless use, penetration of water or other substances into the product.
- Damage caused by accident or natural disaster.

Certificate

Name: _____

Model: _____

Inspectors: _____

Date: _____

Products have been tested qualified by standard and permitted to deliver.

