



APPLIANCES FOR LIVING

 **ARTUSI**
THE ART OF LIVING

ASO600RX & ASO900RX
OPERATION MANUAL

Congratulations, you are now the proud owner of an ARTUSI cooking appliance. Thank you for purchasing ARTUSI and welcome to the ARTUSI Family.

This instruction manual has been specially created to inform you of the full range of features your ARTUSI appliance has to offer and serves as an introduction to getting the very best out of your ARTUSI appliance.

We present detailed information on each of the features your ARTUSI appliance consists of. Once you have read this section you will be able to choose the most appropriate settings for your appliance when cooking different types of food.

We ask you to read the instructions in this booklet very carefully as this will allow you to get the best results from using your appliance. KEEP THE DOCUMENTATION OF THIS PRODUCT FOR FUTURE REFERENCE.

TO REGISTER YOUR PRODUCT WITH ARTUSI, PLEASE FILL OUT THE WARRANTY CARD AT THE END OF THIS BOOKLET AND POST IT TO: **REPLY PAID 83617**
LEICHHARDT NSW 2040

Dear Artusi Customer, please read this user manual carefully before using the product and, keep it permanently at your disposal.

Note: This user manual is prepared for more than one model. Some of the features specified in this Manual may not be available on your appliance.

All our appliances are only for domestic use, not for commercial use. Products marked with (*) are optional.

“THIS APPLIANCE SHALL BE INSTALLED IN ACCORDANCE WITH THE REGULATIONS FORCE AND ONLY USED IN A WELL VENTILATED SPACE. READ THE INSTRUCTIONS BEFORE INSTALLING OR USING THIS APPLIANCE”

“Conforms with the WEEE Regulations.”

HOOD DUCTING GUIDE

Here are some important points to consider when choosing and/or installing a range hood:

- An externally ducted range hood will generally outperform a recirculating range hood.
- We discourage the use of flexible ducting as this has a significant negative impact on airflow and noise due to turbulence
- caused by the ribs. Instead consider using semi-rigid or rigid duct.
- Avoid using a narrower duct than specified as this will reduce airflow; the best performance is obtained when the range hood is installed with a short duct with minimal bends.
- To determine the required clearance between the cooktop and the range hood always consult the installation manual for both the range hood and cooktop. The required clearance is the greater of the distance specified in either manual (and a minimum of 600mm between the highest point of the highest burner for gas cooktops).
- Five metres is the recommended maximum length for ducting (see diagram 1.). When the ducting exceeds five metres in length the installation of a TD500 or TD350 in-line motor is required, which must be placed one metre from the external vent (see diagram 2.).

Diagram 1.

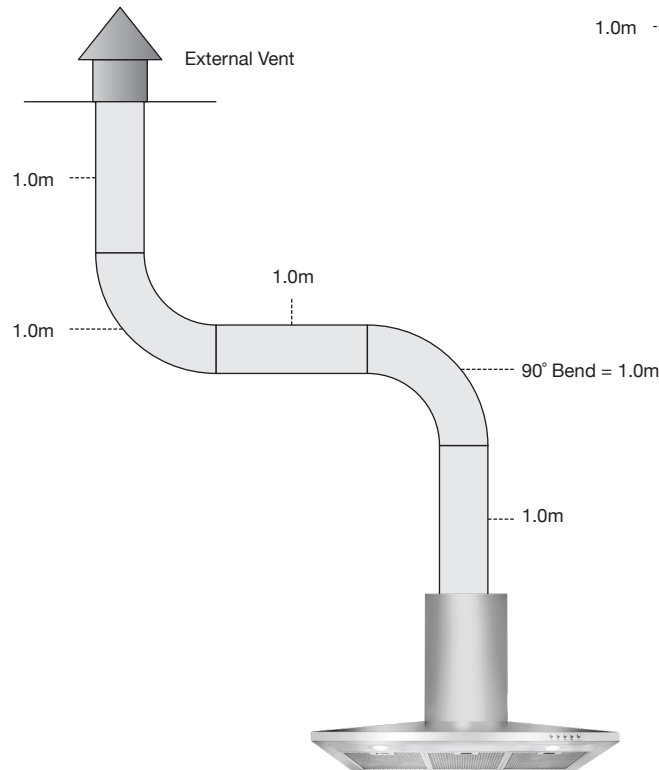
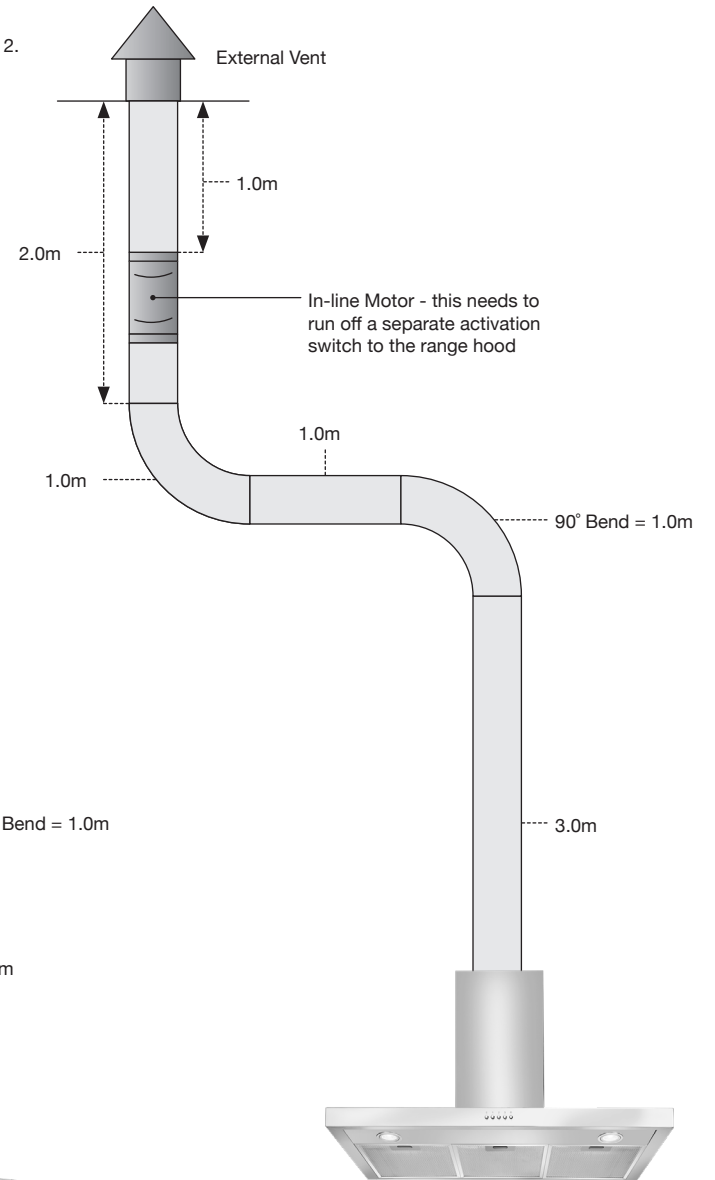
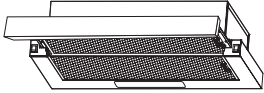

Diagram 2.





Information and advice

Caution: Take care when touching the hood as it may become hot due to high heat from steam and fats when cooking.

In certain circumstances electrical appliances may be a hazard.

Please pay attention to the following points:

- A. Always have air circulating through the room when the hood is in use especially if other appliances burning gas or other fuels are in use.
- B. Never open the filters to check their state while the hood is in use.
- C. Do not touch the lightbulb within 30 minutes of using the hood.
- D. Never flambé under the hood. The flames may cause the hood to catch on fire.
- E. Do not light gas burners on a gas hob without putting a pan or pot over the flame as the flames may damage the filters and are a fire hazard.
- F. Never leave frying food unattended as the oil may catch on fire.
- G. Disconnect the hood from the power supply before any maintenance.
- H. Never allow persons with reduced physical, sensory, mental capabilities or lack of experience and knowledge, including children under the age of 12, to use the hood without supervision and instruction concerning use of the hood.
- I. Supervise children to ensure they do not play with the hood.
- J. Only install this hood over a hob with a maximum of 4 burners/ hot plates.
- K. Immediately if it is damaged replace the power cord with one from the manufacturer, its service agent or similarly qualified to avoid electric shock / fire hazard.

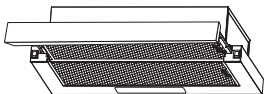

Information and advice

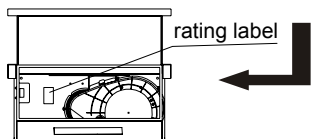
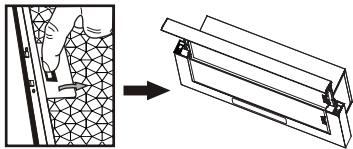

1

Remove the hood from the carton and remove all packaging materials.
Lay it on a padded / protected surface to prevent damage.
Check the voltage and frequency on the rating label inside the hood comply with local standards.

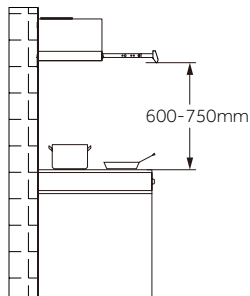

2

Install the hood no less than 600mm and no more than 750mm above the cooking surface.



Caution:
Turn the power off before starting installation.

Selection of venting or recirculation mode

Ducted mode. Insert the big block into the position as per Fig. 3. Keep the small handle rail installed on the hood.

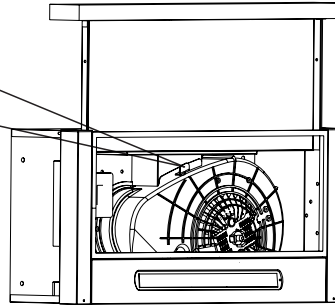

3

Recirculation mode. Insert the small block into the position as per Fig. 4. Remove the small handle rail and attach the larger handle rail.

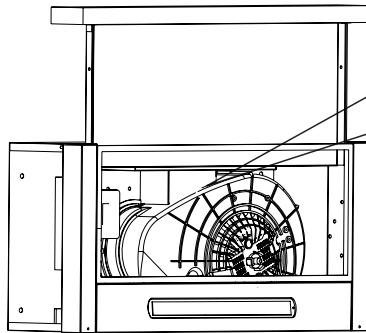

Big mode selection block

Small mode selection block

4

i

Caution:
The air must not be discharged into a duct/flue that is used for exhausting fumes from any other appliances.

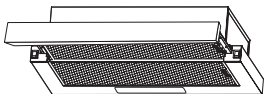

Installation

Ensure the power has been turned off before beginning this installation.

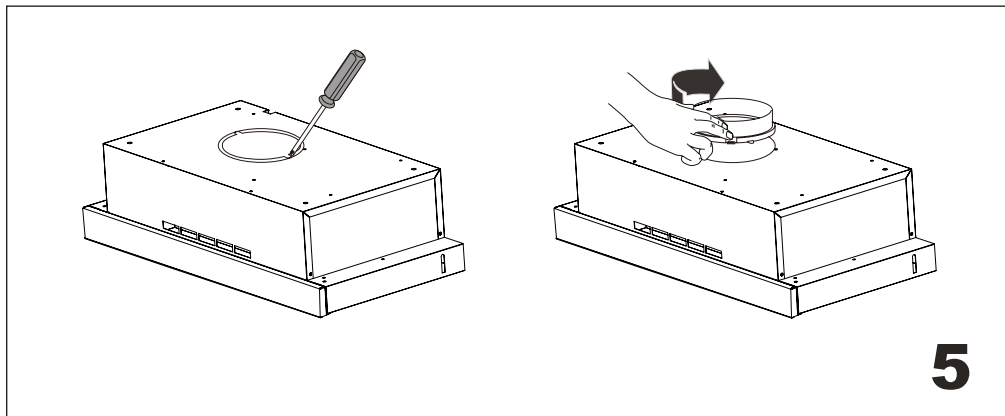

Ducted mode:

Remove the knockout (as per Fig 5) using a flat head screwdriver inserted under one end and gently lever it up.
Cut the attachment points using tin snips and remove.
Screw the damper flap onto the hood as shown.

Recirculation mode:

Leave the knockout in place
Remove the tape from the vents



Caution:
Know where the electrical wiring and other utilities are located behind walls before cutting or drilling into walls or ceilings.

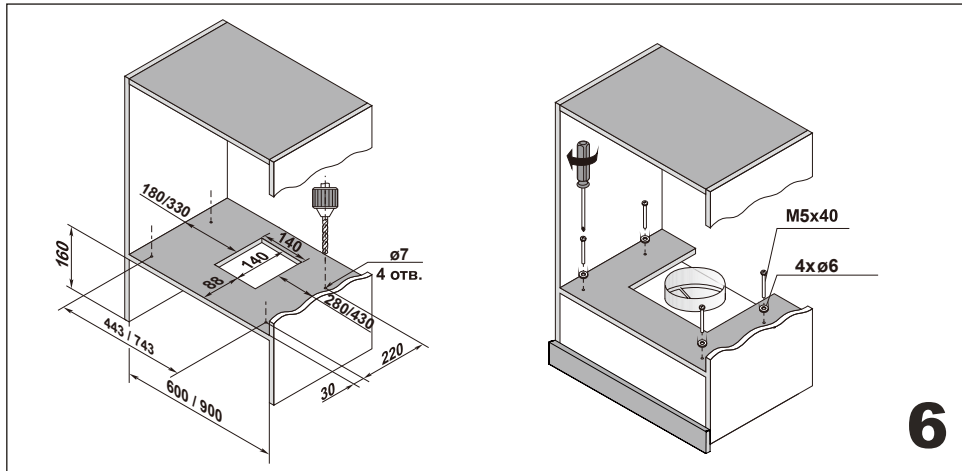

You will need 2 people to install the hood.

Keep the power cord and plug accessible for easy access to the power socket.

Ducting mode: Ensure the hole for the damper flap & duct has been cut in the cabinet.

1. Using the template supplied mark the screw locations in the cabinet. Note: the gap between the rear wall and the hood should not be more than 10mm.
2. Drill 4 x 7mm holes as marked using the template.
3. Make sure the opening in the hood aligns with the ductwork.
4. Put the screws into the expanding plugs (supplied) into the holes
5. Hold the hood in place and screw down until the hood is secured. Check there is no space between the top of the hood and the cabinet.



Caution
Installation work and electrical wiring must be done by qualified person(s) in accordance with all applicable laws, regulations and safety standards.

Caution:
The hood should be power OFF.

6

Ducted mode as per Fig. 7 and 8

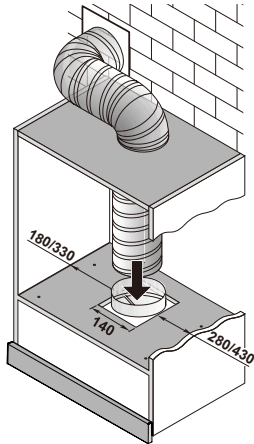

Note: The duct hole is off centre

Connect the hose (not supplied) to the damper flap and place the duct hose into position.

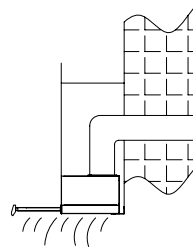

Plug in the appliance when it is fully installed.



Information

The air must not be discharged into a flue that is used for exhausting fumes from appliances burning gas or other fuels.

Controls:

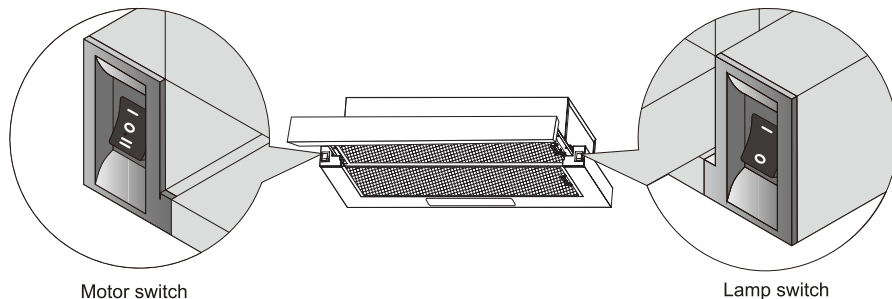

To use

Pull out the telescopic hood using the handle rail. You will hear a click when it is in place. No click, no power, this is the safety switch.

Select the motor speed as per Fig. 9 using the switch on the front of the hood. (0 is off, I is low speed and II is high speed)

Turn on the lamp as per Fig. 9 using the other switch on the front of the hood. (0 is off, I is on)

To turn off

Select motor speed 0

Turn off the light

Push the telescopic piece back into the hood.



Information

Do not touch the light bulb within half an hour after appliance use.

The lamp shall not be covered with thermal insulation or other material.

Cleaning and maintenance instructions

Caution: Turn off the hood before cleaning.

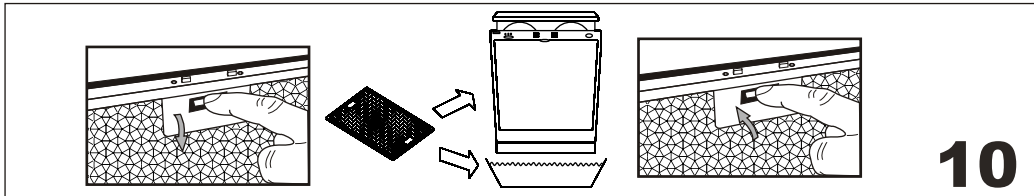

Replacing the
light bulb

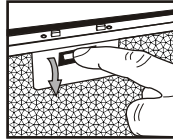

E14 Lamp Max 1x40W



Caution: Wait 30 minutes for the light bulb to cool down after using the hood.
It is hot and may burn!

Open the filter, Remove the old light bulb.
Replace with a new lightbulb (no more than 40W)

11

Information: Clean the filters at least once every 3 months.

Cleaning instructions

1. Clean the surface of the hood frequently using mild soap or detergent.
2. Avoid the use of harsh cleaning agents as it may spoil the hood's appearance.
3. Wash the filters using mild soap or detergent. The filters can be cleaned in a dishwasher.

Note that heavy grease build up may not be able to be cleaned and the filters should be replaced.

4. Never clean the charcoal filters. They must be replaced as necessary.



Information
Never let
water enter
the motor
or electrical
parts as this
may cause
an electric
shock
hazard.

Recycling	
	<p>Please contact your local recycling centre for information on how to correctly dispose of this appliance.</p> <p>The manufacturer shall decline all responsibility when the recommendations and instructions regarding installation, maintenance and use are not observed.</p>

The manufacturer shall decline all responsibility when the recommendations and instructions regarding installation, maintenance and use are not observed.



Worldwide Appliances Pty Limited

A.B.N. 45868077422

Office:

48-50 Moore Street, Leichhardt N.S.W 2040

Post:

Locked Bag 3000, Annandale, N.S.W 2038

P: 1300 694 583

WARRANTY REGISTRATION

Your ongoing satisfaction with your artusi product is important to us. We ask that you complete the enclosed Warranty Registration Card and return it to us so that we have a record of the artusi product purchased by you.

PRIVACY

Worldwide Appliances respects your privacy and is committed to handling your personal information in accordance with the National Privacy Principles and the Privacy Act 1988 (Cth). A copy of the Worldwide Appliances Privacy Policy is available at www.artusi.com.au. Worldwide Appliances will not disclose any personal information set out in the Warranty Registration Card ("Personal Information") without your consent unless required by:

1. law;
2. any Worldwide Appliances related company;
3. any service provider which provide services to artusi or assist artusi in providing services (including repair and warranty services) to customers. Our purpose in collecting the Personal Information is

to keep a record of the artusi product purchased by you, in order to provide a better warranty service to you in the unlikely event that there is a problem with your artusi product. Worldwide Appliances may contact you at any one or more of the address, email address or telephone numbers set out in the Warranty Registration

Card. Please contact artusi on 1300 694 583 should you not wish to be contacted by Worldwide Appliances.

WARRANTY

1. Warranty

Worldwide Appliances warrants that each artusi product will remain, for a period of either 12 months or 24 months of warranty. All Warranties are valid from the original date of purchase, And warranty claims must be accompanied by the proof of purchase.

24 months warranty products:

All Built-in Appliances – Limited to Ovens, Gas, Induction and Electric Cooktops, and All Rangehoods

Freestanding Cookers - Gas and Electric Models (900mm Width)

Dishwashers - Freestanding, Fully Integrated, Semi Integrated and built-in

12 months warranty products:

Freestanding Cookers - Gas and Electric Models in 50cm, 54cm and 60cm Widths

Portable Appliances* – Benchtop Models and Portable Gas Models

2. What is not Covered by the Warranty.

The Warranty does not apply if an artusi product is defective by a factor other than a defect arising in the manufacture of the artusi product, including but not limited to:

- (a) damage through misuse (including failure to maintain, service or use with proper care), neglect, accident or ordinary wear and tear (including deterioration of parts and accessories and glass breakage);
- (b) use for purpose for which the artusi product was not sold or designed;
- (c) use or installation which is not in accordance with any specified instructions for use or installation;
- (d) use or operation after a defect has occurred or been discovered;
- (e) damage through freight, transportation or

handling in transit (other than when Worldwide Appliances is responsible);

(f) damage through exposure to chemicals, dusts, residues, excessive voltage, heat, atmospheric conditions or other forces or environmental factors outside the control or Worldwide Appliances;

(g) repair, modification or tampering by the purchaser or any person other than Worldwide Appliances, an employee of Worldwide Appliances or an authorised artusi service contractor*;

(h) use of parts, components or accessories which have not been supplied or specifically approved by artusi.

(i) damage to surface coatings caused by cleaning or maintenance using products not recommended in the artusi product handbook provided to the purchaser upon purchase of the artusi product;

(j) damage to the base of an electric oven due to items having been placed on the base of the oven cavity or covering the base, such as aluminium foil (this impedes the transfer of heat from the element to the oven cavity and can result in irreparable damage); or

(k) damages, dents or other cosmetic imperfections not affecting the performance of the artusi in respect of an artusi product purchased as a "factory second" or from display. The Warranty does not extend to light globes used in artusi products.

3. Domestic Use

Each artusi product is made for domestic use. This Warranty may not extend to artusi products used for commercial purposes.

4. Time for Claim under the Warranty

You must make any claim under this Warranty within twenty eight (28) days after the occurrence of an event which gives rise to a claim pursuant to the Warranty, by booking a service call on the telephone number below.

Continued over...

5. Proof of Purchase

Customers must retain proof of purchase in order to be eligible to make a warranty claim in respect of an artusi product.

6. Claiming under the Warranty

Customers will bear the cost of claiming under this Warranty unless Worldwide Appliances determines the expenses are reasonable, in which case the customer must claim those expenses by providing written evidence of each expense to Worldwide Appliances at the address on the Warranty Registration Card.

7. Statutory Rights

(a) These terms and conditions do not affect your statutory rights.

(b) The limitations on the Warranty set out in this document do not exclude or limit the application of the consumer guarantees set out in the Act or any other equivalent or corresponding legislation in the relevant jurisdiction where to do so would:

- (i) contravene the law of the relevant jurisdiction; or
- (ii) cause any part of the Warranty to be void.

(c) Worldwide Appliances excludes indirect or consequential loss of any kind (including, without limitation, loss of use of the artusi product) and (other than expressly provided for in these terms and conditions) subject to all terms,

conditions and warranties implied by custom, the general law, the Act or other statute.

(d) The liability of Worldwide Appliances to you for a breach of any express or non-excludable implied term, condition or warranty is limited at the option of Worldwide Appliances to:

- (i) replacing or repairing the defective part of the artusi product;
- (ii) paying the cost of replacing or repairing the defective part of the artusi product;
- (iii) replacing the artusi product; or
- (iv) paying the cost of replacing the artusi product.

(e) Our goods come with guarantees that cannot be excluded under the Australian Consumer Law. You are entitled to a replacement or refund for a major failure and for compensation for any other reasonably foreseeable loss or damage. You are also entitled to have the goods repaired or replaced if the goods fail to be of acceptable quality and the failure does not amount to a

major failure.

8. Defects

Any part of an artusi product deemed to be defective and replaced by Worldwide Appliances is the property of Worldwide Appliances. Worldwide Appliances reserves the right to inspect and test artusi products in order to determine the extent of any defect and the validity of a claim under the Warranty.

*To locate your closest artusi authorised service agent please contact us on 1300 652 100 or visit www.artusi.com.au

ALL SERVICE CALLS MUST BE BOOKED THROUGH AN AUTHORISED DEALER OR WARRANTY DEPARTMENT ON 1300 652 100 OR stokesaps.com.au/artusi-service
01032014



Warranty Card tear off

WARRANTY REGISTRATION CARD 01052013

Please complete and send to ARTUSI at: REPLY PAID 83617
LEICHHARDT NSW 2040

Last Name:		First Name:	
Address:			
State:	Postcode:	Email:	
Home Phone:		Mobile:	
Purchase Date: / /		(Please attach proof of purchase to validate warranty)	

MODEL NUMBER	SERIAL NUMBER (if you cannot locate the serial number please call ARTUSI on 1300 694 583)
1	
2	
3	
4	

01032014





DISCLAIMER

Worldwide Appliances PTY LTD, trading as ARTUSI, is continually seeking ways to improve the design specifications, aesthetics and production techniques of its products. As a result alterations to our products and designs take place continually. Whilst every effort is made to produce information and literature that is up to date, this brochure should not be regarded as an infallible guide to the current specifications, nor does it constitute an offer for the sale of any particular product. Product dimensions indicated in our literature is indicative only. Actual product only should be used to define dimension cutouts. Distributors, and retailers are not agents of ARTUSI and are not authorised to bind ARTUSI by any express or implied undertaking or representation.

ARTUSI OFFICES ARE OPEN DAILY FROM 9AM-5PM AND SATURDAYS 10AM-4PM

NSW & ACT (HEAD OFFICE)
48-50 MOORE STREET
LEICHHARDT
F 02 8569 4699

VIC, TAS & SA
1211 TOORAK ROAD
CAMBERWELL
F 03 9809 2155

QLD
1/42 CAVENDISH ROAD
COORPAROO
F 07 3397 0850

WA & NT
UNIT 10/55 HOWE STREET
OSBORNE PARK
F 08 9201 9188

NZ
PO BOX 11160
SOCKBURN CHRISTCHURCH
F 03 344 5906

P: 1300 649 583

ARTUSI.COM.AU

