

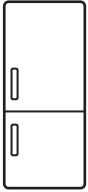

Electrolux



electrolux.com/register



EN User Manual | Fridge Freezer



CONTENTS

1. IMPORTANT SAFETY INFORMATION.....	2
2. FEATURES.....	5
3. INSTALLATION.....	5
4. CONTROLS AND SETTINGS.....	12
5. STORING FOOD AND SAVING ENERGY.....	13
6. NORMAL OPERATING SOUNDS.....	13
7. CARE AND CLEANING.....	14
8. TROUBLESHOOTING.....	15
9. LIMITED WARRANTY.....	15
10. QUEBEC RIGHT TO REPAIR.....	17

1. IMPORTANT SAFETY INFORMATION

1.1 Keep a record for quick reference

Model number

.....

Serial number

.....

Purchase date

.....

1.2 Serial number location

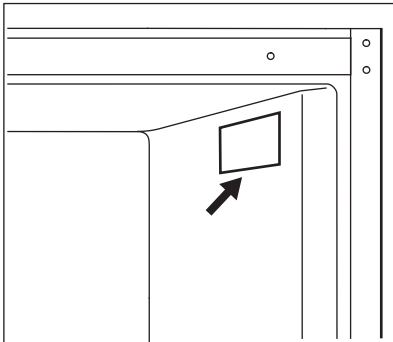

WARNING!

You must follow these guidelines to ensure that your appliance's safety mechanisms are operating correctly.

1.3 Safety definitions



This is the safety alert symbol. It is used to alert of potential personal injury hazards. Obey all safety messages that follow this symbol to avoid possible injury or death.

DANGER

DANGER indicates an imminently hazardous situation which, if not avoided, will result in death or serious injury.

WARNING!

WARNING indicates a potentially hazardous situation which, if not avoided, could result in death or serious injury.

CAUTION!

CAUTION indicates a potentially hazardous situation which, if not avoided, may result in minor or moderate injury.

IMPORTANT

IMPORTANT indicates installation, operation or maintenance information which is important but not hazard-related.

1.4 Child safety

This appliance is not intended for use by persons (including children) with reduced physical, sensory or mental capabilities, or lack of experience and knowledge, unless they have been given supervision or instruction concerning use of the appliance by a person responsible for their safety.

Destroy or recycle the carton, plastic bags, and any exterior wrapping material immediately after the appliance is unpacked. Children should never use these items to play. Cartons covered with rugs, bedspreads, plastic sheets or stretch wrap may become airtight chambers, and can quickly cause suffocation.

1.5 Important safety instructions

DANGER



Risk of fire or explosion.
Flammable refrigerant used.
Do not use mechanical devices to defrost the appliance. Do not puncture refrigerant tubing.
Risk of fire or explosion.
Flammable refrigerant used.
To be repaired only by trained service personnel. Use only manufacturer-authorized service parts. Any repair equipment used must be designed for flammable refrigerants. Follow all manufacturer repair instructions. Do not puncture refrigerant tubing.

WARNING!

Do not use the appliance before installing it in the built-in structure.

CAUTION!



Risk of fire or explosion due to puncture of refrigerant tubing. Follow handling instructions carefully. Flammable refrigerant used.

This appliance is for storage only and should not be used for any other purpose.
Do not store or use gasoline or other flammable vapors and liquids in the vicinity of this or any other appliance.
Do not store explosive substances such as aerosol cans with a flammable propellant in this appliance.
Do not operate the appliance in the presence of explosive fumes
Avoid contact with any moving parts of automatic ice maker.
Remove all staples from the carton. Staples can cause severe cuts, and

also destroy finishes if they come in contact with other appliances or furniture.

⚠ WARNING!

Do not use electrical appliances inside the food storage compartments of the appliance unless they are of the type recommended by the manufacturer.

⚠ WARNING!

CALIFORNIA RESIDENTS ONLY
WARNING! Cancer and Reproductive Harm <http://www.P65Warnings.ca.gov>

1.6 Proper disposal of your appliance

⚠ CAUTION!



Risk of fire or explosion. Dispose of the appliance properly in accordance with the applicable federal or local regulations. Flammable refrigerant used.

Risk of child entrapment

Child entrapment and suffocation are not problems of the past. Junked or abandoned appliances are still dangerous – even if they will sit for “just a few days”. If you are getting rid of your old appliance, follow the instructions below to help prevent accidents.

We strongly encourage responsible appliance recycling/disposal methods. Check with your utility company or visit <http://www.energystar.gov/recycle> for more information on recycling your old appliance.

Before you throw away your old appliance:

- Remove doors.
- Leave shelves in place so children may not easily climb inside.
- Have it removed by a qualified service technician.

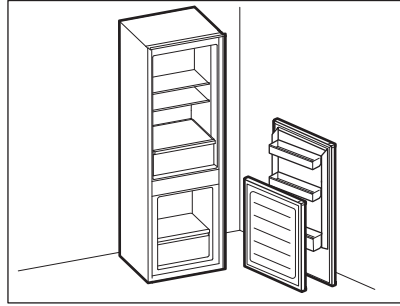

1.7 Electrical information

- The appliance must be plugged into its own dedicated 115 Volt, 60 Hz., 15 Amp, AC only electrical outlet. The power cord of the appliance is equipped with a three-prong grounding plug for your protection against electrical shock hazards. It must be plugged directly into a properly grounded three-prong receptacle. The receptacle must be installed in accordance with local codes and ordinances. Consult a qualified electrician. Do not use an extension cord or adapter plug.

⚠ WARNING!

Avoid fire hazard or electric shock.

- If the power cord is damaged, it should be replaced by an authorized service technician to prevent any risk.
- Never unplug the appliance by pulling on the power cord. Always grip the plug firmly, and pull straight out from the receptacle to prevent damaging the power cord.
- Unplug the appliance before cleaning and before replacing the light bulb to avoid electrical shock. Use only a 5-watt or less AC LED light bulb.
- Performance may be affected if the voltage varies by 10% or more. Operating the appliance with insufficient power can damage the compressor. Such damage is not covered under your warranty.
- Do not plug the unit into an electrical outlet controlled by a wall switch or pull cord to prevent the appliance from being turned off accidentally.

- Do not pinch, knot, or bend the power cord in any manner.

⚠ WARNING!

When positioning the appliance, ensure the supply cord is not trapped or damaged.
Do not locate multiple portable socket-outlets or portable power supplies at the rear of the appliance.

⚠ WARNING!

Do not, under any circumstances, cut, remove, or bypass the grounding prong (A). Always use the power cord with a three-prong grounded plug and grounding type wall receptacle.



2. FEATURES

➡ IMPORTANT

Features may vary by model.

Accessories are available for your appliance and may be purchased at Frigidaire.com or by calling toll-free 1-800-374-4432 or from an authorized seller.

2.1 Product overview

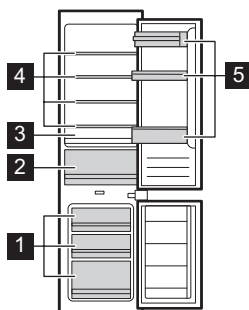

- 1 Freezer drawers
- 2 Crisper
- 3 Fruit and vegetables drawer
- 4 Glass shelves
- 5 Bins

3. INSTALLATION

This User Manual provides general installation and operating instructions for your model. We recommend using a service or kitchen contracting professional to install your appliance. Use the appliance only as instructed in this User Manual. Before starting the appliance, follow these important first steps.

3.1 Location

- If possible, place the appliance out of direct sunlight and away from the range, dishwasher, or other heat sources.
- The appliance must be installed on a floor that is level and strong enough to support a fully loaded appliance.

⚠ WARNING!

This appliance is intended for use in residential household and similar interior applications such as:

- Kitchen / kitchenette
- Pantry room
- Basement
- Enclosed garage
- Other interior residential type environments

CAUTION!

Do not install the appliance where the temperature will drop below 55°F (13°C) or rise above 110 °F (43 °C). The compressor will not be able to maintain proper temperatures inside the appliance.

NOTE

Do not block the lower front of the appliance.
Sufficient air circulation is essential for the proper operation of the appliance.

WARNING!

Risk of damage or injury due to the appliance tipping over. This appliance is very heavy and may tip forward when the door is open. Keep the door(s) closed until the appliance is fully installed. Secure the appliance in its installation niche in accordance with the operating and installation instructions.

WARNING!

Fire hazard and risk of damage from heat-emitting appliances and from open flames. Heat-emitting appliances can ignite and cause the appliance to catch fire. Open flames can set fire to the appliance. Keep open flames (such as a candle) away from the appliance.

3.2 Ventilation

CAUTION!

Fire hazard and risk of damage due to insufficient ventilation.

NOTE

If the appliance is not ventilated sufficiently, the compressor runs more frequently and for longer periods. This causes increased energy consumption and increased compressor operating temperature, which can result in damage to the compressor.
Ensure there is adequate ventilation around the appliance. It is essential to observe the required ventilation gaps. Do not obstruct them and clean them on a regular basis to remove dust.

Keep a gap of at least 1/2inch (13mm) between the back of the appliance and the rear wall. Not maintaining the gap results in increased energy consumption.

Air at the back of the appliance gets warm. To provide sufficient space for ventilation refer to Installation Dimensions and the Installation Instructions.

- To ensure ventilation provide an air channel of a minimum 1 1/2inch (40mm) depth at the back of the appliance.
- The ventilation openings in the toe-kick, inside the cabinet, and beneath the cabinet top must provide a combined airflow area of at least 31 in² (200 cm²) to ensure unobstructed heat dissipation.
- To fit a grille in the ventilation openings, the ventilation openings must be larger than 31"2 (200 cm²). The passage volume of 31"2 (200 cm²) is the total area of the opening slits in the grille.

IMPORTANT

The larger the ventilation slits, the more economically the appliance works.

3.3 Leveling

When positioning the appliance, ensure that it is level, with all bottom corners resting firmly on a solid floor. You can adjust this using the two leveling feet located at the front bottom of the appliance.

3.4 Dimensions

Dimensions below are for reference only and should not be used to order or make

wood panels. Use them only to help calculate the panel size.

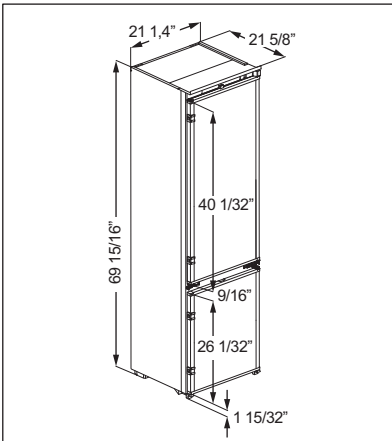
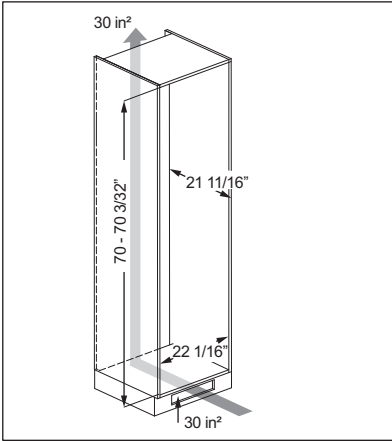

3.5 Cabinet Door Panels

Built-in installation of the appliance requires refrigerator and freezer cabinet door panels.

The cabinet door panel must be between 5/8" and 7/8" thick.

Cabinet Door Panel Weight

⚠ CAUTION!

If the door panel is too heavy, damage can occur. A door panel that is heavier than the maximum permitted weight can damage the hinges, causing functional problems.

IMPORTANT

Before you install the door panel, make sure that its weight does not exceed the maximum permitted weight.

The maximum permitted weights of the door panels are:

- Refrigerator door panel: 39.7 lb (18 kg)
- Freezer door panel: 26.5 lb (12 kg)

Cabinet Door Panel Size

The size of the cabinet door panel depends on your kitchen design and on the gap between the cabinet doors. When you choose the height of the door panel, make sure the top edge aligns with the doors of the surrounding cabinets. The door panel must fit correctly and must not be under tension.

Horizontal and Vertical Gaps

The required gaps around the door panel depend on the kitchen style, the thickness of the door panel, and the edge radius. Consider this when planning your kitchen or replacing the appliance to meet installation requirements.

- Horizontal gap
The gap between the door panel and the unit door above or below must be at least 1/8" (3 mm).
- Vertical gap
If the gap between the refrigeration appliance door panel and the adjacent unit door or wall on the hinge side is too small, the appliance door can hit the adjacent unit or wall when opened. You may need to adjust this gap to match the thickness and edge radius of the door panel.

Cabinet door panel installed next to the unit door

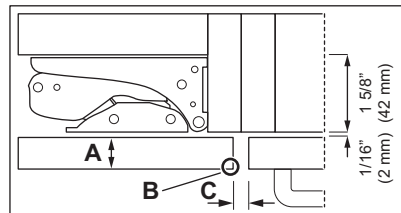

Cabinet door panel installed next to the wall

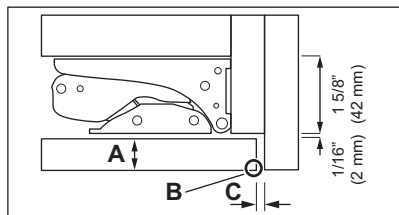

Dimensions (DIM):

- A. Cabinet door panel thickness
- B. Edge radius
- C. Gap

Door panel thickness "DIM A"	"DIM C" for different edge radii "B"			
	R 0	R 1.2	R 2	R 3
5/8" - 3/4" 16 - 19 mm			min. 1/8" min. 3 mm	
13/16" 20 mm	3/16" 5 mm	3/16" 4 mm	3/16" 4 mm	1/8" 3.5 mm
13/16" 21 mm	3/16" 5.5 mm	3/16" 5 mm	3/16" 4.5 mm	3/16" 4 mm
7/8" 22 mm	1/4" 6.5 mm	1/4" 6 mm	3/16" 5.5 mm	3/16" 5 mm

Door Panels

Appliance dimensions

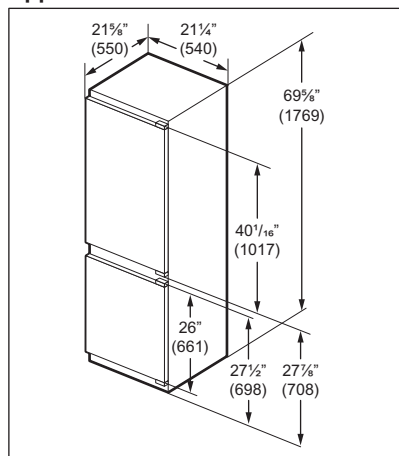

Custom Door Panel Dimensions

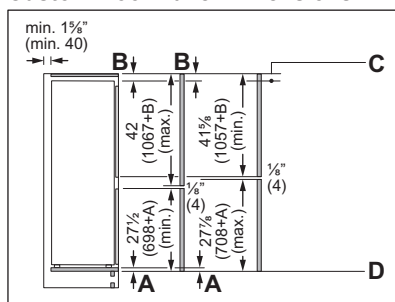

- A. Distance measured by the customer
 - B. Distance measured by the customer
 - C. Front panel overhang
 - D. Lower edge of front panel
- The specified appliance door dimensions are valid for a door gap of 1/8" (4mm).

3.6 Built-in Installation

Required tools:

- 13mm wrench
- T20 Screwdriver
- Screwdriver
- Level

To install the appliance:

1. Position the appliance in front of kitchen cabinet opening. Connect power cord. With doors still attached tilt the appliance forward and push into the cabinet opening..

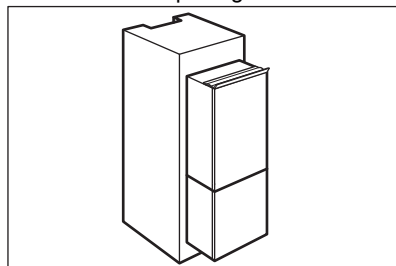

2. To level the appliance use a level and the provided hex wrench. Adjust the front 2 hex feet as needed.

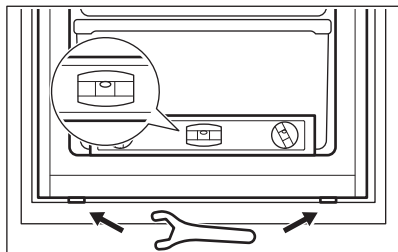

3. Loosely set the depth of the appliance. Use the doors to align the depth of appliance.
4. Remove top cover from both doors and set aside.

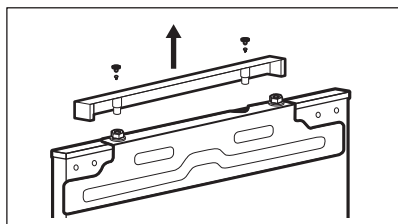

5. Remove lower freezer door and the hinges..

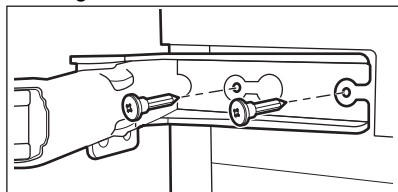

6. Using a clean flat surface place the wood freezer panel face down. Place the removed freezer door face down onto the wood panel.
7. Center the door onto wood panel right to left. Then align the door vertically where it needs to be in relation to adjoining kitchen cabinetry

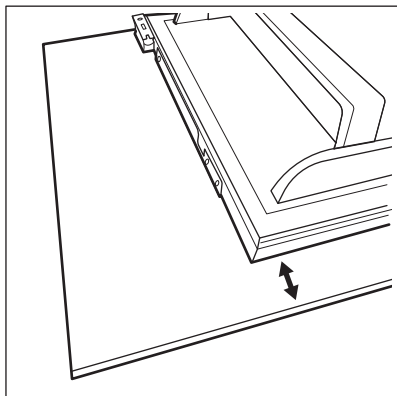

8. Mark a pencil line on the door using the top door mounting bracket as a template.

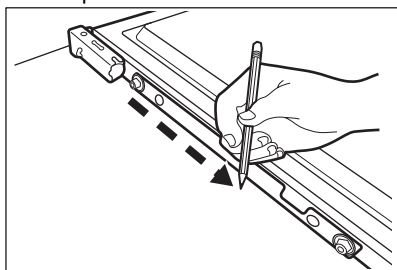

9. Remove the metal bracket from the door and align it to the pencil mark on the wood panel. Attach the bracket on the wood panel using screws..
10. Reattach the wood panel with metal bracket back onto the door.

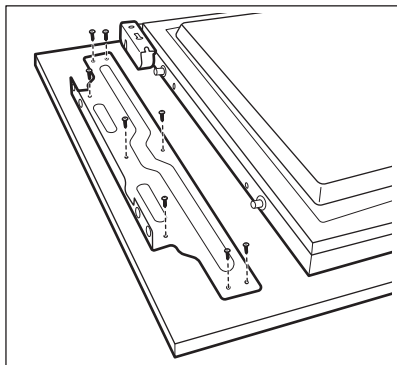

11. Put the appliance's doors onto the metal brackets on the cabinet's doors.
12. Attach the bottom of the door to the wood panel using the "L" brackets

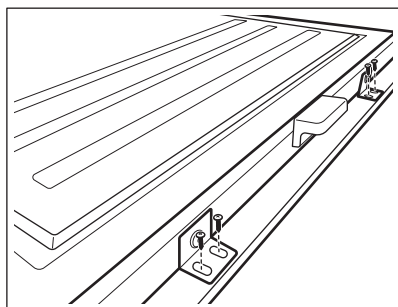

13. Reattach door and hinges to the appliance (step 5).
14. Reattach the top cover (step 4).
15. Repeat the steps for the refrigerator door.
16. With doors and panels installed on the appliance ensure the cabinet depth is positioned so doors close and door gaskets seal properly.
17. Secure the top flanged bracket against fixed shelf in the kitchen cabinet to set the depth of the appliance. Insert 2 screws through metal bracket into the kitchen cabinet. Install the screw covers provided in the installation kit.

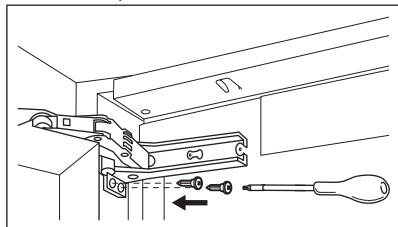

18. Insert screws through the 2 bottom braces to secure the appliance to the bottom of the kitchen cabinet. Snap the provided plastic covers from the installation kit.

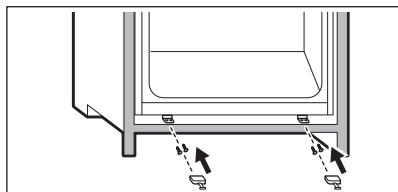

19. Secure sides of hinges to the side wall of the kitchen cabinet (8 screws).

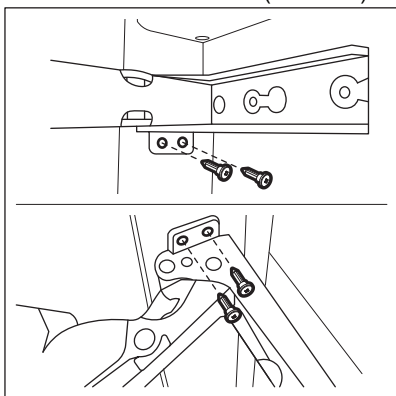

20. With the refrigerator door open, visually inspect the freezer gasket to ensure it is sealing on all sides
21. Open the freezer door and inspect the refrigerator door to make sure the gasket is sealing on all sides. Adjust as needed to ensure gaskets seal properly.

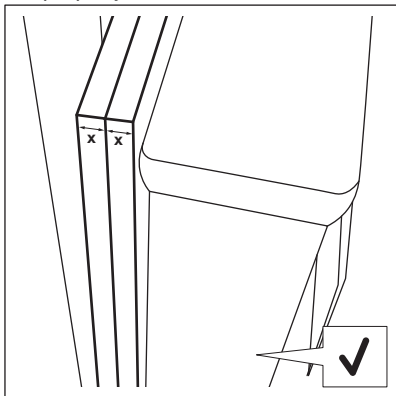

22. Install the cabinet seal on the opposite side of the door hinges.

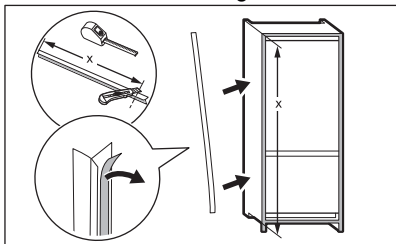

23. Use the #13 wrench to adjust the height of doors with the nuts. Use T20 screwdriver to tighten the bolts

and adjust the gaps between the wooden door and the cabinet.

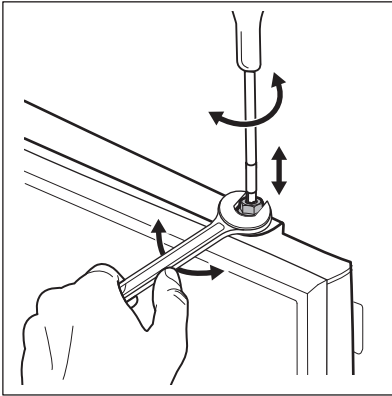

24. If further adjustments are required, use the hinge shims provided in the installation bag. Use these shims placed behind hinges to adjust doors forward and away from cabinet. Adjust as needed.

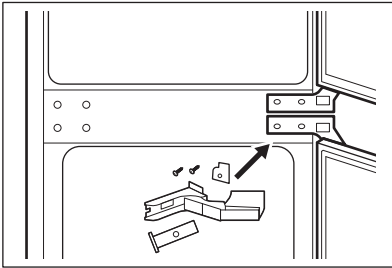

3.7 Door reversal

1. Remove both doors by removing the 8 screws. Set them aside.

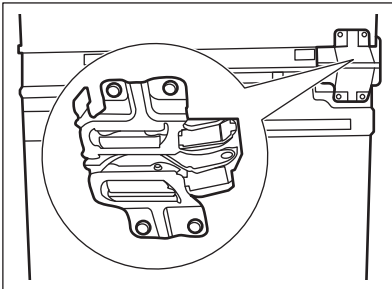

2. Remove the cover on the opposite side of the hinge next to user interface.

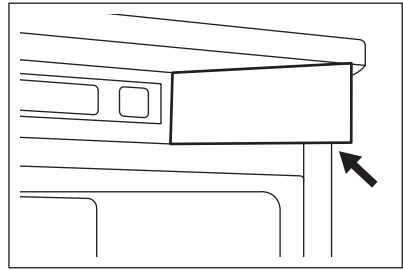

3. Remove the 6 plastic hole plug covers using a small flathead screwdriver. Set aside the hole plugs for the opposite side.



4. Remove the 4 hinges by removing the 8 mounting screws. Use hand force only. Criss-cross the hinges and install them on the opposite side of the appliance.

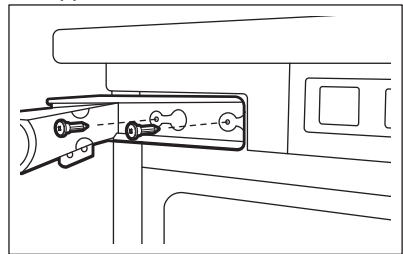

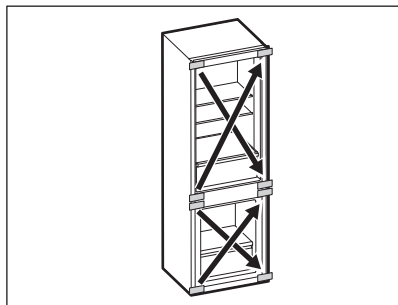

- Remove the "L" shaped cover and replace it with a new rectangular trim supplied in the door reversal bag.

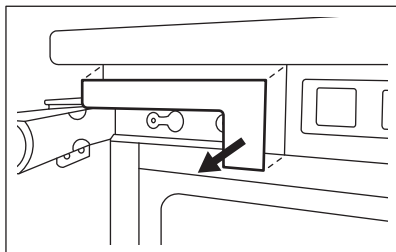

- On the refrigerator door top hinge install the new "L" trim provided in the door reversal bag.
- Reinstall the plastic plugs on the opposite side of the appliance.
- Reattach the doors. Tighten the 8 mounting screws by hand.

4. CONTROLS AND SETTINGS

4.1 Appliance Control

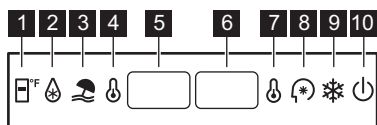

- Chiller Zone**
Press to adjust the temperature in the crisper. The temperature range varies between 37°F (3°C) and 27°F (-3°C).
- Fast Cooling**
Press to activate the function, the button lights up. The function sets the temperature in the refrigerator compartment to 36°F (2°C). It stops after 24h.
- Holiday**
Press to activate the function, the button lights up. The function sets the temperature in the refrigerator compartment to 63°F (17°C) and in the freezer compartment to 0°F (-18°C).
- Refrigerator temperature adjustment**
Press to adjust the refrigerator compartment temperature. The temperature range varies between 34°F (1°C) and 43°F (6°C).
- Refrigerator temperature display**
- Freezer temperature display**

- Freezer temperature adjustment**
Press to adjust the freezer compartment temperature. The temperature range varies between 5°F (-15°C) and -9°F (-23°C).
- Eco**
Press to activate the function, the button lights up. The function sets the temperature in the refrigerator compartment to 41°F (5°C) and in the freezer compartment to 0°F (-18°C). The temperature in the Chiller Zone is set to 37°F (3°C).
- Fast Freezing**
Press to activate the function, the button lights up. The function sets the temperature in the freezer compartment to -13°F (-25°C). It stops after 24h.
- On/Off**
Press the button for 3sec to turn the power on/off. The button lights up when turned on.

NOTE

No frost models are equipped with automatic defrosting function. Press **Freezer temperature adjustment** and **On/Off** for 5sec to activate/deactivate.

5. STORING FOOD AND SAVING ENERGY

5.1 Ideas for storing food

Fresh food storage

- Keep the fresh food compartment between 34°F and 40°F, with an optimum temperature of 37°F.
- Avoid overcrowding the refrigerator shelves, which reduces air circulation and causes uneven cooling.
- Avoid placing food in front of air ports.

Fruits and vegetables

- Store fruits and vegetables in crisper drawers, where trapped moisture helps preserve food quality for longer time periods.
- Wash items and remove excess water.
- Wrap any items that have strong odors or high moisture content.

Meat

- Wrap raw meat and poultry separately and securely to prevent leaks and contamination of other foods or surfaces.

Frozen foods storage

- Keep the freezer compartment at 0°F or lower.
- A freezer operates most efficiently when it is at least 2/3 full.

Packaging foods for freezing

- To minimize food dehydration and quality deterioration, use aluminum foil, freezer wrap, freezer bags, or airtight containers. Force as much air out of the packages as possible and seal them tightly. Trapped air can cause food to dry out, change color, and develop an off-flavor (freezer burn).
- Wrap fresh meats and poultry with suitable freezer wrap prior to freezing.
- Do not refreeze meat that has completely thawed.

Loading the freezer

- Avoid adding too much warm food to the freezer at one time. This overloads

the freezer, slows the rate of freezing, and can raise the temperature of frozen foods.

- Leave a space between packages, so cold air can circulate freely, allowing food to freeze as quickly as possible.

5.2 Ideas for energy saving

Installation

- Locate the refrigerator in the coolest part of the room, out of direct sunlight, and away from heating ducts or registers.
- Do not place the refrigerator next to heat-producing appliances such as a range, oven, or dishwasher. If this is not possible, a section of cabinetry or an added layer of insulation between the two appliances will help the refrigerator operate more efficiently.
- Level the refrigerator so that the doors close tightly.

Temperature setting

- Refer to Controls and Settings for procedures on temperature settings.

Food storage

- Avoid overcrowding the refrigerator or blocking cold air vents. Doing so causes the refrigerator to run longer and use more energy.
- Cover foods and wipe containers dry before placing them in the refrigerator. This cuts down on moisture build-up inside the unit.
- Organize the refrigerator to reduce door openings. Remove as many items as needed at one time and close the door as soon as possible.
- Do not place a hot container directly on a cold shelf. Remember, such an extreme temperature change may damage the glass.

6. NORMAL OPERATING SOUNDS

NOTE

The appliance can make various sounds. This is normal.

NOTE

During automatic defrost cycle, a red glow in the back wall vents for your freezer compartment is normal.

IMPORTANT

Ice maker models only: If the ice maker is not connected to the water supply, you may hear a chattering noise. Turn off the ice maker by pressing the green On/Off power switch until you install the water supply line.

6.1 Understanding the sounds you may hear

- **Evaporator:** Refrigerant flows through the evaporator, making a boiling or gurgling sound.
- **Evaporator fan:** Moves air through the appliance, creating a blowing sound.

- **Defrost heater:** During defrost cycles, water dripping onto the defrost heater causes a hissing or sizzling sound. After defrosting, a popping sound occurs.
- **Ice maker:** Ice cubes drop into the bin, making a sound during each cycle.
- **Compressor:** Runs with a humming or pulsating sound.
- **Water valve:** Opens to fill the ice maker, making a brief buzzing sound.
- **Drain pan (not removable):** Water drips into the drain pan during defrost, making a sound.
- **Condenser:** Air moves across the condenser, making an airflow sound.

7. CARE AND CLEANING

7.1 Vacation and moving tips

Short vacations

- Leave the appliance operating during vacations of three weeks or less.
- Use all perishable items from the appliance compartment.

Long vacation

- Remove all food and ice if you will be gone one month or more.
- Unplug the appliance.
- Clean interior thoroughly.
- Leave both doors open to prevent odors and mold build-up. Block doors open if necessary.

Moving

- Unplug the appliance
- Remove all food and ice.
- Recommend use of a handcart, load from the side.
- Adjust rollers all the way up to protect them during sliding or moving.
- Pad cabinet to avoid scratching surface.

7.2 Care & Cleaning Tips

Part	What to use	Tips and precautions
Interior and door liners	<ul style="list-style-type: none">• Soap and water• Baking soda and water	Use 2 tablespoons of baking soda in 1 quart of warm water. Be sure to wring excess water out of sponge or cloth before cleaning around controls, light bulb or any electrical part.
Door gaskets	Soap and water	Wipe gaskets with a clean soft cloth.
Glass shelves	<ul style="list-style-type: none">• Soap and water• Glass cleaner• Mild liquid sprays	Allow glass to warm to room temperature before immersing in warm water.
Exterior	<ul style="list-style-type: none">• Soap and water	Never use chloride or cleaners with bleach to clean stainless steel. Always clean, wipe and dry with the grain to prevent scratching. Wash the rest of the cabinet with warm water and mild liquid detergent. Rinse well, and wipe dry with a clean soft cloth.

8. TROUBLESHOOTING

Let us help you troubleshoot your concern! This section will help you with common issues. If you need us, visit our website, chat with an agent, or call us. We may be able to help you avoid a service visit. If you do need service, we can get that started for you! Visit Frigidaire.com or call toll-free 1-800-374-4432.

8.1 Common occurrences

The appliance does not run.	<ul style="list-style-type: none">• Ensure the plug is tightly pushed into an electrical outlet.• Check/replace the fuse with a 15amp time-delay fuse. Reset the circuit breaker.• The appliance may be in defrost cycle. Wait 20 minutes and check again.
The appliance temperature is unsatisfactory.	<ul style="list-style-type: none">• Set the appliance control to a warmer or colder setting until the temperature is satisfactory. Allow 24 hours for the temperature to stabilize.
The appliance is noisy or vibrates.	<ul style="list-style-type: none">• The cabinet is not level.• Floor is weak.
Odors in the appliance.	<ul style="list-style-type: none">• The interior needs to be cleaned.• Cover or wrap the foods that produce odors.
Cabinet light is not working.	<ul style="list-style-type: none">• Ensure the plug is tightly pushed into an electrical outlet.

8.2 Errors

The following error codes might appear on the display indicating the malfunction of the appliance. The refrigerator may operate despite the following errors.

Error Code	Description
F2	Issue in the chiller zone.
F3	Issue in the refrigerator compartment.
F4	Issue in the freezer compartment.
F5	Defrosting issue.

Error Code	Description
2E	Fan/motor malfunction in the freezer compartment.
CE	Appliance control issue.

NOTE

When the freezer compartment temperature rises above 77°F (-1°C), the alarm sounds and temperature digit flashes. Press any button to stop the alarm. The digit flashes until the freezer cools down.

9. LIMITED WARRANTY

Your appliance is covered by a one-year limited warranty. For one year from your date of delivery, Electrolux will pay all costs for repairing or replacing any parts of this appliance that prove to be defective in materials or workmanship when such appliance is installed, used and

maintained in accordance with the provided instructions.

Exclusions

This warranty does not cover the following:

1. Products with original serial numbers that have been removed, altered or cannot be readily determined.

2. Product that has been transferred from its original owner to another party or removed outside the USA, Puerto Rico, or Canada.
3. Rust on the interior or exterior of the unit.
4. Products purchased “as-is” are not covered by this warranty.
5. Food loss due to any refrigerator or freezer failures.
6. Products used in a commercial setting.
7. Service calls which do not involve malfunction or defects in materials or workmanship, or for appliances not in ordinary household use or used other than in accordance with the provided instructions.
8. Service calls to correct the installation of your appliance or to instruct you how to use your appliance.
9. Expenses for making the appliance accessible for servicing, such as removal of trim, cupboards, shelves, etc., which are not a part of the appliance when it is shipped from the factory.
10. Service calls to repair or replace appliance light bulbs, air filters, water filters, other consumables, or knobs, handles, or other cosmetic parts.
11. Surcharges including, but not limited to, any after hour, weekend, or holiday service calls, tolls, ferry trip charges, or mileage expense for service calls to remote areas, including the state of Alaska.
12. Damages to the finish of appliance or home incurred during transportation or installation, including but not limited to floors, cabinets, walls, etc.
13. Damages caused by: services performed by unauthorized service companies; use of parts other than genuine Electrolux parts or parts obtained from persons other than authorized service companies; or external causes such as abuse, misuse, inadequate power supply, accidents, fires, or acts of God.

DISCLAIMER OF IMPLIED WARRANTIES; LIMITATION OF REMEDIES

CUSTOMER’S SOLE AND EXCLUSIVE REMEDY UNDER THIS LIMITED WARRANTY SHALL BE PRODUCT REPAIR OR REPLACEMENT AS

PROVIDED HEREIN. CLAIMS BASED ON IMPLIED WARRANTIES, INCLUDING WARRANTIES OF MERCHANTABILITY OR FITNESS FOR A PARTICULAR PURPOSE, ARE LIMITED TO ONE YEAR OR THE SHORTEST PERIOD ALLOWED BY LAW, BUT NOT LESS THAN ONE YEAR. ELECTROLUX SHALL NOT BE LIABLE FOR CONSEQUENTIAL OR INCIDENTAL DAMAGES SUCH AS PROPERTY DAMAGE AND INCIDENTAL EXPENSES RESULTING FROM ANY BREACH OF THIS WRITTEN LIMITED WARRANTY OR ANY IMPLIED WARRANTY. SOME STATES AND PROVINCES DO NOT ALLOW THE EXCLUSION OR LIMITATION OF INCIDENTAL OR CONSEQUENTIAL DAMAGES, OR LIMITATIONS ON THE DURATION OF IMPLIED WARRANTIES, SO THESE LIMITATIONS OR EXCLUSIONS MAY NOT APPLY TO YOU. THIS WRITTEN WARRANTY GIVES YOU SPECIFIC LEGAL RIGHTS. YOU MAY ALSO HAVE OTHER RIGHTS THAT VARY FROM STATE TO STATE.

If You Need Service

Keep your receipt, delivery slip, or some other appropriate payment record to establish the warranty period should service be required. If service is performed, it is in your best interest to obtain and keep all receipts. Service under this warranty must be obtained by contacting Electrolux at the addresses or phone numbers below.

This warranty only applies in the USA, Puerto Rico and Canada. In the USA and Puerto Rico, your appliance is warranted by Electrolux Consumer Products, Inc. In Canada, your appliance is warranted by Electrolux Canada Corp. Electrolux authorizes no person to change or add to any obligations under this warranty. Obligations for service and parts under this warranty must be performed by Electrolux or an authorized service company. Product features or specifications as described or illustrated are subject to change without notice.

USA

1-877-435-3287

Electrolux Consumer Products, Inc.



North America
 10200 David Taylor Drive
 Charlotte, NC 28262
Canada
1-800-265-8352

Electrolux Canada Corp.
 5855 Terry Fox Way
 Mississauga, Ontario, Canada L5V 3E4

10. QUEBEC RIGHT TO REPAIR

Though Electrolux makes every effort to make replacement parts, repair services and information necessary to maintain or repair our products available to consumers, parts, service and information are not guaranteed, pursuant to section 39 of the Consumer Protection Act, CQLR, c. P-40.1 and sections 79.18 to 79.20 of the Regulation respecting the application of the Consumer Protection Act, CQLR, c. P-40.1, r. 3. If you need replacement parts, you may call us at 1 (800) 265-8352 for service in French or English.







You may book repair services online at [information](#) | [Book a service](#) | [Electrolux](#). Alternatively, our resource library is available at [Resource Library](#) | [Electrolux](#) to help you diagnose and resolve issues which may arise during the lifetime of your appliance.

Though most parts are available for purchase, subject to short-term availability

constraints, the following appliances and parts are not serviceable.

Legend

Availability of replacement parts, repair services, and information for maintenance or repair.

	Partially Available
	Not Available
	Available
Refrigerators	 Cabinet, 14cu ft and less no sealed system parts
Freezer	 9 cu. ft and less no sealed system parts.
Beverage Centers	 Only cosmetic parts available

A series of 20 horizontal dotted lines for writing.

A series of 20 horizontal dotted lines for writing.

