



USE & CARE MANUAL AND COOKING GUIDE

Kenmore®

MICROWAVE OVEN

STOCK NOS. 89247
89380
89381

Read these instructions carefully before use. If you follow the instructions, your microwave oven will provide you with many years of good service.

SAVE THESE INSTRUCTIONS

TABLE OF CONTENTS

Safety Instructions

■ PRECAUTIONS TO AVOID POSSIBLE EXPOSURE TO EXCESSIVE MICROWAVE ENERGY . . . inside cover	
■ Important Safety Instructions	1

Setting up & Getting to Know Your Oven

■ Electrical Grounding Instructions	2
■ Installation	2
■ Names of Oven Parts and Accessories	3
■ Control Panel and Features	4
■ Setting Clock	5
■ Child Lock-Out	5
■ Utensils	6

Operating Instructions

■ Automatic Popcorn	7
■ Quick-On Cooking	7
■ Automatic Defrost by Weight	8
■ Quick Touch Food Reheating	9
■ Quick Touch Frozen Food Cooking	10
■ Time Cooking	11
■ Hold Warm	12
■ Minute Timer	12
■ Multistage Cooking	12
■ Instrucciones de Operacion (Spanish)	13

Care of Your Microwave Oven

■ Questions and Answers	21
■ Cleaning	22
■ Before Calling for Service	22

Cooking Guide

■ Cooking Techniques	23
■ Appetizers	24
■ Soups and Sandwiches	25
■ Vegetables and Rice	26
■ Meats, Poultry and Fish	27
■ Eggs	29
■ Baked Goods and Desserts	30

Chart

■ Quick-On Cooking Chart	31
■ Automatic Defrost Chart	32
Sears Service	33
Warranty	33
Easy Use Chart	back cover



SPECIFICATIONS

	89247	89380/89381
Power Source	AC 120 V, 60 Hz	AC 120 V, 60 Hz
Power Consumption	1260W	1260W
Maximum Output	800W*	800W*
Oven Capacity	0.9 cu. ft.	0.9 cu. ft.
Turntable Diameter	13-3/8" (340 mm)	13-3/8" (340 mm)
Dimensions (w x h x d)	20-11/16" x 11-1/16" x 16-7/16" 525 mm x 281 mm x 417 mm	20-11/16" x 11-1/16" x 16-1/2" 525 mm x 281 mm x 419 mm
Weight (Approx.)	34.2 lbs. (15.5 kg)	34.2 lbs. (15.5 kg)

*According to IEC-705 test procedures.

Specifications subject to change without notice.

KENMORE is a registered trademark of Sears, Roebuck and Co..

PROPER AND SAFE USE OF YOUR OVEN

- The oven must be level.
- The turntable and turntable roller rest must be in the oven during cooking.
- Place the cookware gently on the turntable and handle it carefully to avoid possible breakage.
- Incorrect use of browning dish may cause the turntable to break. See page 6.
- Use only the specified bag size when using Automatic Popcorn.
- The oven has several built-in safety switches to ensure that the power remains off when the door is open. Do not tamper with these switches.
- Do not operate the microwave oven empty.
- Do not cook bacon directly on the turntable. Excessive local heating of the turntable may cause it to break.
- Do not heat baby bottles or baby food in the microwave oven. Uneven heating may occur and could cause physical injury.
- Do not heat narrow-necked containers, such as syrup bottles.
- Do not attempt to deep-fry in your microwave oven.
- Do not do home canning in this microwave oven as it is impossible to be sure all contents of the jar have reached boiling temperature.
- Do not use this microwave oven for commercial purposes. This microwave oven is made for household use only.

PRECAUTIONS TO AVOID POSSIBLE EXPOSURE TO EXCESSIVE MICROWAVE ENERGY

- Do not attempt to operate this oven with the door open since open-door operation can result in harmful exposure to microwave energy. It is important not to defeat or tamper with the safety interlocks.
- Do not place any object between the oven front face and the door or allow soil or cleaner residue to accumulate on sealing surfaces.
- Do not operate the oven if it is damaged. It is particularly important that the oven door closes properly and that there is no damage to the:
 - DOOR (bent)
 - HINGES AND LATCHES (broken or loosened)
 - DOOR SEALS AND SEALING SURFACES
- Do not adjust or repair microwave oven yourself. Microwave ovens should be repaired by properly qualified service technicians.

IMPORTANT SAFETY INSTRUCTIONS

When using electrical appliances, basic safety precautions should be followed, including the following:

WARNING – To reduce the risk of burns, electric shock, fire, injury to persons or exposure to excessive microwave energy:

1. Read all instructions before using.
 2. Read and follow the specific "PRECAUTIONS TO AVOID POSSIBLE EXPOSURE TO EXCESSIVE MICROWAVE ENERGY" on the previous page.
 3. As with most cooking appliances, close supervision is necessary to reduce the risk of a fire in the oven cavity.
- If a fire should start:**
- Keep the oven door closed
 - Turn the oven off, and
 - Disconnect the power cord or shut off power at the fuse or circuit breaker panel.
- Keep in mind the following rules at all times:**
- a. Do not grossly overcook foods, as they may cause a fire in the oven cavity. Always attend the oven. Be watchful, if paper, plastic, or other combustibles are placed inside the oven.
 - b. Do not use the cavity for storage purposes. Do not store combustible items such as bread, cookies, paper products, etc. inside the oven. If lightning strikes the power line, the oven may turn on by itself.
 - c. Do not use wire twist-ties in the oven. Be sure to inspect purchased items for wire twist-ties and remove before placing them in the oven.
 4. This oven must be grounded. Connect only to properly grounded outlet. See "GROUNDING INSTRUCTIONS" on page 2.
 5. Install or locate this oven only in accordance with the provided installation instructions.
 6. Some products such as eggs in the shell, water with oil or fat, sealed containers and closed glass jars may, for example, explode and therefore should not be heated in this oven.
 7. Use this oven only for its intended uses as described in the manual. This type of oven is specifically designed to heat or cook food. It is not designed for industrial or laboratory use. Never use corrosive chemicals or vapors in this oven.
 8. As with any appliance, children should use the oven only under adult supervision.
 9. Do not operate this oven if it has a damaged cord or plug, is not working properly or has been damaged or dropped.
 10. This appliance should be serviced only by qualified service technicians. Contact the nearest authorized service facility for examination, repair or adjustment.
 11. Do not cover or block any vents on the oven.
 12. Do not store or use this appliance outdoors.
 13. Do not use this oven near water, near a kitchen sink, in a wet basement or near a swimming pool.
 14. Do not immerse cord or plug in water.
 15. Keep cord away from heated surfaces.
 16. Do not let cord hang over edge of table or counter.
 17. When cleaning door and interior oven surfaces, use only mild non-abrasive soaps or detergents applied with a sponge or soft cloth. (See "Cleaning" instructions on page 22.)

SAVE THESE INSTRUCTIONS

ELECTRICAL GROUNDING INSTRUCTIONS

This appliance must be grounded. If there is an electrical short circuit, grounding reduces the risk of electric shock by providing an escape wire for the electric current. This appliance is equipped with a cord that has a grounding wire with a grounding plug. The plug must be plugged into an outlet that is properly installed and grounded.

Consult a qualified electrician if the grounding instructions are not completely understood as to whether the appliance is properly grounded.

Properly polarized and grounded outlet

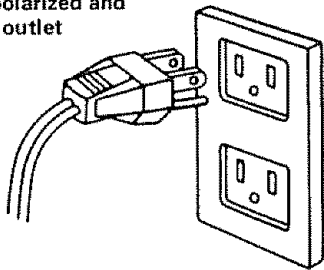

Three-pronged (grounding) plug

A short power supply cord is provided to reduce the risk of becoming entangled in or tripping over a longer cord.

Longer cord sets or extension cords may be used with following precautions:

- The marked electrical rating of the cord set or extension cord should be equal to or higher than the electrical rating of the appliance.
- The extension cord must be a grounding-type 3-wire cord.
- Longer cord should be arranged so that it will not drape over the countertop or tabletop where it can be pulled on by children or tripped over accidentally.

The electrical power cord must be kept dry and must not be pinched or crushed in any way.

WARNING - Improper use of the grounding plug can result in electric shock.

INSTALLATION

Remove all packing material and accessories. Examine the oven for any damage such as dents or broken door. Do not install if oven is damaged.

1. Select a level surface that provides enough open space (see illustration at right) for the inlet and/or outlet vents.
 - Leave a minimum clearance of 3 inches (7.5 cm) above the oven.
 - Do not remove the legs from the bottom of the oven.
 - Blocking the inlet and/or outlet openings can damage the oven.
 - Do not install oven over a range, cooktop or other heat-producing appliance.
 - Cabinet is covered with a protective film which should be removed to fully show the intended color and finish.
2. Plug your oven into a standard 120-volt / 60-Hz household outlet. Be sure the electrical circuit is at least 15 amperes and that your microwave oven is the only appliance on the circuit.

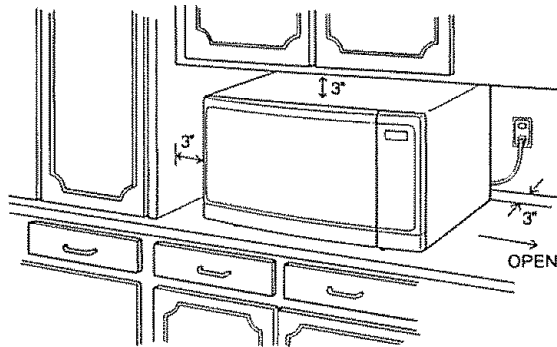

A minimum clearance of 3 inches (7.5 cm) is required between the oven and any adjacent wall. One side must be open.

NOTE:

This unit is not designed for 50 Hz or any circuit other than a 120-volt/60-Hz AC circuit. This oven is designed for countertop installation only. Insertion into a cabinet or wall will damage the product and void the warranty.

NAMES OF OVEN PARTS AND ACCESSORIES

Remove the oven and all materials from the carton.

Your oven comes with the following accessories:

Turntable	1
Turntable roller rest	1
Use & Care Manual	1

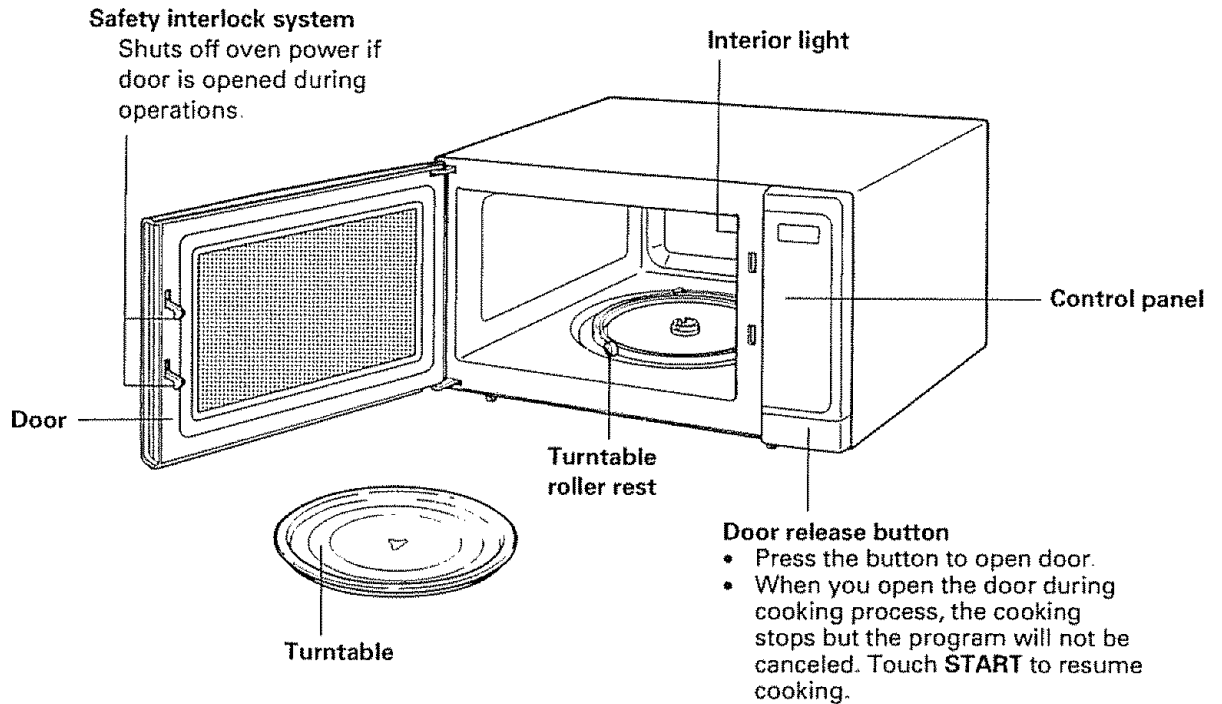

TURNTABLE INSTALLATION

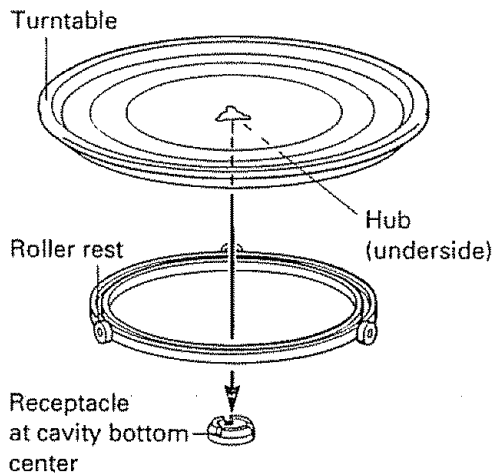

1. Place the roller rest on the cavity bottom.
 2. Place the turntable on top of the roller rest as shown in the diagram. Make sure the turntable hub is securely locked in the receptacle. **Never place the turntable upside down.**
- Both turntable and roller rest must always be used during cooking.
 - All food and containers of food are always placed on this turntable for cooking.
 - This turntable returns to its original starting position when cooking is finished.
 - This turntable rotates clockwise and counterclockwise; this is normal.

CONTROL PANEL AND FEATURES

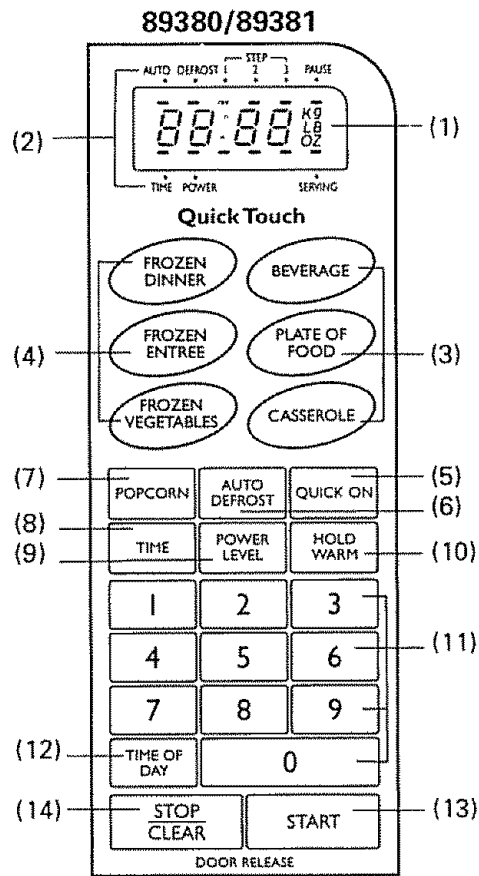
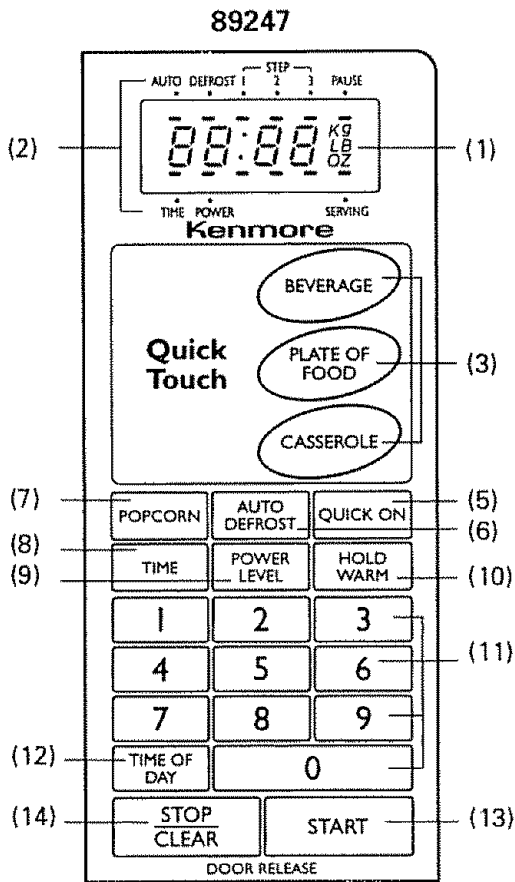

(1) Display Window

Counts down cooking time in seconds during cooking. Shows clock time when oven is not in use.

(2) Indicators

STEP1/ STEP2/ STEP3 :

Cooking stage indicators

AUTO/ DEFROST/ PAUSE :

Cooking mode indicators

TIME/ POWER/ SERVING/ LB/ oz : A flashing indicator prompts you to enter desired cooking time, power setting, food weight or number of servings.

Quick Touch menu keypads

(3) Reheating menu keypads (page 9)

(4) Frozen food menu keypads (page 10)
[89380/89381 only]

Auto menu keypads

(5) QUICK ON (page 7)

(6) AUTO DEFROST (page 8)

(7) POPCORN (page 7)

(8) TIME keypad (page 11)

(9) POWER LEVEL keypad (page 11)

(10) HOLD WARM keypad (page 12)

(11) Number keypad

(12) TIME OF DAY keypad (page 5)

(13) START keypad

(14) STOP/CLEAR keypad

Clears all previous setting if pressed before cooking starts. During cooking: touch once to stop oven; twice to stop and clear all entries.



Beep Sound

A beep tone sounds when a keypad on the control panel is touched to indicate a setting has been entered.

SETTING CLOCK

When your oven is plugged in for the first time or when power resumes after a power interruption, the numbers in the display reset to **0:00**. Set the clock.

Example: To set 3:15 :

1.  Touch **TIME OF DAY**.
2.  Touch number keypads **3**, **1** and **5**.
3.  Touch **TIME OF DAY**.
The clock starts counting.

Remember:

- If the clock (or display) shows any abnormality, unplug the oven from the AC outlet. Plug it in again and then reset the clock.

CHILD LOCK-OUT

Your oven has a safety feature to prevent a playful or accidental running of the oven by a child. Even if the oven is accidentally programmed to cook, no cooking takes place when this feature is set.

To set :

1. Touch **TIME OF DAY**.
2. Touch **9** four times.
3. Touch **START**.

Indicator **L** lights and clock display reappears.

To cancel :

1. Touch **TIME OF DAY**.
2. Touch **7** four times.
3. Touch **START**.

Indicator **L** disappears and clock display reappears.

UTENSILS

MATERIALS YOU CAN USE IN MICROWAVE OVEN

Utensils	Use	Remarks
Aluminum foil	Shielding	Small smooth pieces can be used to cover thin parts of meat or poultry to prevent overcooking. Arcing can occur if foil is too close to oven walls. Should be at least 1 inch (2.5 cm) away from oven walls.
Browning dish	Searing meats	Follow manufacturer's instructions. The bottom of browning dish must be at least 3/16 inch (5 mm) above the turntable. Incorrect usage may cause the turntable to break.
Dinnerware	Reheating and short-term cooking	Microwave-safe only. Follow manufacturer's instructions. Do not use cracked or chipped dishes.
Glass jars	Warming	Always remove lid. Use only to heat food until just warm. Most glass jars are not heat resistant and may break.
Glassware	Cooking	Heat-resistant oven glassware only. Make sure there is no metallic trim. Do not use cracked or chipped dishes.
Oven cooking bags	Cooking	Follow manufacturer's instructions. Do not close with metal tie. Make slits to allow steam to escape.
Paper plates and cups	Short-term warming and cooking	Use for short-term cooking/warming only. Do not leave oven unattended while cooking.
Paper towels	Reheating and short-term cooking	Use to cover food for reheating and absorbing fat. Use with supervision for a short-term cooking only.
Parchment paper	Cooking	Use as a cover to prevent spattering or a wrap for steaming.
Plastic	Reheating and short-term cooking	Microwave-safe only. Follow the manufacturer's instructions. Should be labeled "Microwave Safe." Some plastic containers soften as the food inside gets hot.
Plastic wrap	Cooking	Microwave-safe only. Use to cover food during cooking to retain moisture.
Thermometers	Cooking	Microwave-safe only (meat and candy thermometers).
Wax paper	Cooking	Use as a cover to prevent spattering and to retain moisture.

MATERIALS TO BE AVOIDED IN MICROWAVE OVEN

Utensils	Remarks
Aluminum tray	Aluminum tray may cause arcing. Transfer the frozen dinner into a microwave-safe dish before cooking. See page 10.
Food carton with metal handle	May cause arcing. Transfer food into microwave-safe dish.
Metal or metal-trimmed utensils	Metal shields the food from microwave energy. Metal trim may cause arcing.
Metal twist ties	They may cause arcing and could cause a fire in the oven.
Paper bags	May cause a fire in the oven.
Plastic foam cups	Plastic foam may melt or contaminate the liquid inside when exposed to high temperature.
Wood	Wood will dry out when used in the microwave oven and may split or crack.

UTENSIL TEST: Fill a microwave-safe container with 1 cup of cold water (250 mL) and place it in the oven along with the utensil in question. Cook on **HI** power for 1 minute. Carefully feel the utensil. If the empty utensil is warm, it should not be used for microwave cooking. **Do not exceed 1 minute testing time.** This test cannot be used for plastic containers.

CAUTION:

Make sure that closed containers are opened and plastic pouches pierced before cooking. Tightly-closed utensils could explode.

AUTOMATIC POPCORN

This feature lets you pop a 3.5 oz (100 g) prepackaged microwave popcorn quickly and easily.

Popcorn Popping Tips:

- Microwave popcorn bag should be at room temperature.
- Place only one bag in the oven at a time. Follow package instructions. Do not increase quantity.
- Popcorn popping devices are not recommended for use with this feature.

Example: To pop one bag of 3.5 oz (100 g) microwave popcorn:

1.



Touch **POPCORN**.
Display shows bag size.

2.

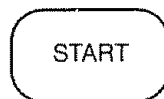

Touch **START**.
Popping begins, and the display shows the time counting down.

Remember:

- If popcorn bag size is not 3.5 oz (100 g), follow instructions on the package and do not use this feature.
- Do not leave the oven unattended while the corn is being popped.
- Remember to supervise children closely.

CAUTION:

- After popping, open bag carefully. Popcorn and steam are extremely hot.
- Do not reheat unpopped kernels or reuse bag. Overcooking can result in an oven fire.
- Never use brown paper bag for popping corn.

QUICK-ON COOKING (HI-POWER)

A time-saving feature, this simplified control lets you quickly set and start microwave cooking without the need to touch **START**.

You can choose from nine preset cooking time selections (1 to 9 minutes) to cook at highest power level (**HI**). Quick-On cooking chart appears on page 31.

Example: To set Quick-On cooking 2 minutes:

1.



Touch **QUICK ON**.

2.

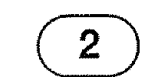

Touch **2**.
The oven begins cooking and display shows time counting down.

Remember:

- You may open the door to stop cooking before the selected time is over. To start again, close the door and touch **START**.

AUTOMATIC DEFROST BY WEIGHT

The Auto Defrost by Weight feature is an accurate defrosting method for frozen food up to 5.9 lb. The oven automatically selects 1 lb. If food weight is more or less than 1 lb, enter the weight using the number keypads.

Pause
This feature has a built-in pause mechanism to allow for checking, turning, separating or rearranging the food. The oven is programmed to stop at the end of the first defrost period (about ¼ of the total defrost time). If you do not open the door at the pause, the oven restarts after 5 minutes.







Auto Defrosting chart appears on page 32.

For manual defrosting using Time Cooking, see page 11.

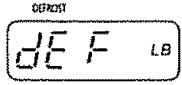
Defrosting Tips:

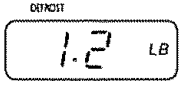
- Check the food during defrosting.
- Remove frozen food from its original paper or plastic package (wrapper). When it is difficult to remove the wrap, remove it at pause.
- Place foods in a flat microwave-safe baking dish or roasting rack to catch drippings.
- Food should still be somewhat icy in the center when removed from the oven.
- The Auto Defrost menu includes standing time.

Example: To defrost 1.2 lb of chicken pieces:

1.  Touch **AUTO DEFROST**.

2.   Enter the weight by touching **1** and then **2**.

3.  Touch **START**.
4. The oven stops automatically at pause. Separate, rearrange or turn food over.

5.  Touch **START**.

Remember:

- The oven automatically selects 1 lb if the weight is not entered.
- To enter a weight of less than 1 lb, always press **0** first. For example, to enter 0.2 lb, press **0** and then **2**.
- Only one digit can be entered after a decimal point. If in doubt, convert to the lower number.

Conversion Chart	
Ounces	Tenth of a Pound
1 - 2	0.1
3 - 4	0.2
5	0.3
6 - 7	0.4
8	0.5
9 - 10	0.6
11 - 12	0.7
13	0.8
14 - 15	0.9



QUICK TOUCH FOOD REHEATING

BEVERAGE, PLATE OF FOOD, CASSEROLE feature keypads are present on your oven control panel. These keypads allow you to reheat one to three servings of room temperature (or refrigerated, but not frozen) foods automatically. Simply touch the appropriate keypads, once for each serving and then touch **START**.

Food Reheating Tips:

- Foods must be room or refrigeration temperature.
- Follow the directions included in the chart.
- When reheating food, place larger and denser food near the outer edge of the plate.
- Stir food after reheating.

Example: To reheat 2 cups of soup:

1.



twice

Touch **BEVERAGE** twice.

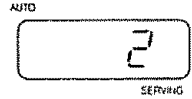

Enter the number of servings by touching a desired menu keypad:

Touch menu keypad	To reheat
once	1 serving
twice	2 servings
3 times	3 servings

2.



Touch **START**.
Reheating starts. The time counts down in the display.

Item	Amount	Directions
BEVERAGE Coffee/Tea Soup Hot Chocolate	1 cup (8 oz or 230 mL)	No cover. Stir after reheating. Cover. Stir after reheating. No Cover. Stir after reheating.
PLATE OF FOOD	1 serving (8 oz or 230 g)	Cover with wax paper. To reheat 2 to 3 servings, place on a large plate.
CASSEROLE	1 cup (6 oz or 170 g)	Cover. Let stand 5 minutes.

NOTE: Use microwave-safe cup, plate or casserole only.

QUICK TOUCH FROZEN FOOD COOKING [89380/89381 only]

FROZEN DINNER, FROZEN ENTREE, FROZEN VEGETABLES feature keypads are present on your oven control panel. Use these keypads to heat precooked frozen foods. The oven automatically determines required cooking time and power for each frozen food item according to your keypad entry.

Frozen Food Cooking Tips:

- Follow package directions for removing or venting cover, piercing pouch, replacing foil, covering with plastic wrap, etc.
- For best results, use this feature with foods that are packaged in single pouches rather than in two or more pouches.
- For best results, remove frozen food from aluminum or foil containers and place on microwave-safe plate or dish.
- Frozen foods with special packaging to "crisp" foods such as pizza, french fries and pocket-type sandwiches should be cooked according to manufacturer's directions. Place on a heat-safe /microwave -safe plate or dish.

Example: To heat 11 oz (310 g) of prepackaged Frozen Dinner:

1.



twice

Touch **FROZEN DINNER** twice.

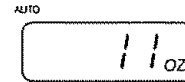

You can enter the food weight by touching desired menu keypad as shown in the chart below.

Recommended food weights

Touch menu keypad	once	twice	3 times
FROZEN DINNER	7 oz	11 oz	15 oz
FROZEN ENTREE	6 oz	9 oz	20 oz
FROZEN VEGETABLES	5 oz	10 oz	20 oz

2.



Touch **START**.
Cooking starts.
The display changes to cooking time countdown.

Remember

FROZEN DINNER with desserts

- Remove dessert if package directions recommend.

FROZEN ENTREE with side dish such as macaroni and cheese, mashed potatoes, rice, pasta:

- Place a microwave-safe plate underneath if the package contains a cheese sauce in the product (macaroni and cheese, for example) that could spill over during heating.

FROZEN VEGETABLES

- Follow package directions for adding water, piercing pouch, cooking in dish, venting package, etc.

TIME COOKING

This basic microwave cooking method allows you to cook food for a desired time. In addition to the **HI** (maximum) power level, you can select different microwave power from 9 levels, **1** (10% of total power) to **9** (90% power) for the foods that require slower cooking. The oven also provides power level **0** (no power).









Foods with high moisture content should be cooked on maximum power, as this is the fastest cooking method and best maintains the natural flavor and texture of the foods.

To check the power level during cooking, touch **POWER LEVEL**. The power level appears in the display window.

Manual Defrosting

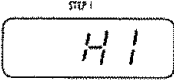
For manual defrosting (without using Auto Defrost features), use power level 3. To speed up the defrosting of dense foods over 1 lb (450 g), you may start on **HI** for **3 minutes**, then reduce to the level 3.

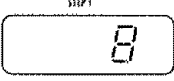
Example: To cook at power level 8 for 40 seconds:

1.  Touch **TIME**.
2.   Enter 40 seconds by touching **4** and then **0**.
3.  Touch **POWER LEVEL**.  STEP 1
POWER
4.  Touch **8** to select power level 8. The display shows **8**.  STEP 1
POWER
5.  Touch **START**.

Remember:

- Cooking time can be set up to 99 minutes 99 seconds.
- When you cook on HI power, skip steps 3 and 4.

MULTIPOWER SETTING GUIDE

Power Level	Cooking Examples
1	<ul style="list-style-type: none"> • Softening cream cheese • Keeping casseroles and main dishes warm.
2	<ul style="list-style-type: none"> • Softening chocolate and clarifying butter • Heating breads, rolls, pancakes, tacos, tortillas and French toast • Taking the chill out of fruit. Heating small amounts of food.
3	<ul style="list-style-type: none"> • Completing the cooking cycle of casseroles, stews and sauces • Manual defrosting • Thawing meat, poultry and seafood.
4	<ul style="list-style-type: none"> • Cooking less tender cuts of meat in liquid or slow-cooking dishes • Completing the cooking cycle of less tender roasts.
5	<ul style="list-style-type: none"> • Cooking stews and soups after bringing to a boil • Cooking custards and pasta • Cooking rump roast, ham, veal and lamb.
6	<ul style="list-style-type: none"> • Cooking scrambled eggs. Baking cakes.
7	<ul style="list-style-type: none"> • Cooking cheese dishes, eggs and milk.
8	<ul style="list-style-type: none"> • Reheating precooked or prepared food quickly.
9	<ul style="list-style-type: none"> • Cooking onions, celery and green peppers quickly • Reheating meat slices quickly.
HI	<ul style="list-style-type: none"> • Cooking poultry, fish, vegetables and most casseroles • Preheating a browning dish. Boiling water.

HOLD WARM

Hold Warm keeps food warm up to 100 minutes after a cooking program is completed or until the door is opened or **STOP/CLEAR** is pressed. **HOLD** appears in the display.

You can also use Hold Warm alone without setting a cooking program, or with any of the featured cooking programs.

1.



Touch **HOLD WARM**.

2.

Set the desired cooking program.

3.



Touch **START**.
After cooking program, **HOLD** appears in the display.

MINUTE TIMER

You can use the timer function of your oven for purposes other than cooking.

Example: To set 3 minutes for a telephone call:

1.



Touch **TIME**.

2.



Touch **3**, **0** and **0**.

3.



Touch **POWER LEVEL**.

4.



Touch **0** (power level 0).

5.

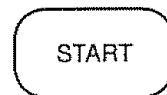

Touch **START**.

MULTISTAGE COOKING

You can program up to 3 stages of cooking in sequence. Auto Defrost by Weight can be programmed before the first stage to defrost first and then cook.

- To program 2-stage or 3-stage cooking, repeat the Time Cooking steps 1 to 4 on the previous page and touch **START**.
- Using the Minute Timer feature for the first stage, you can delay cooking start time by up to 99 minutes and 99 seconds.

INSTRUCCIONES DE OPERACION

PANEL DE CONTROLES Y FUNCIONES

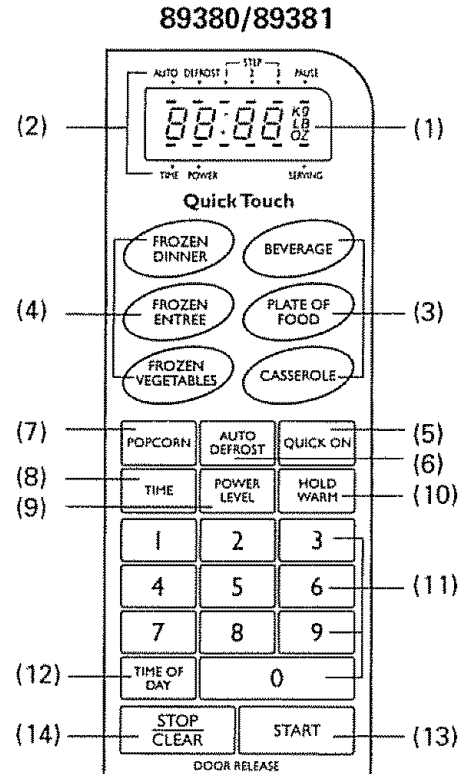
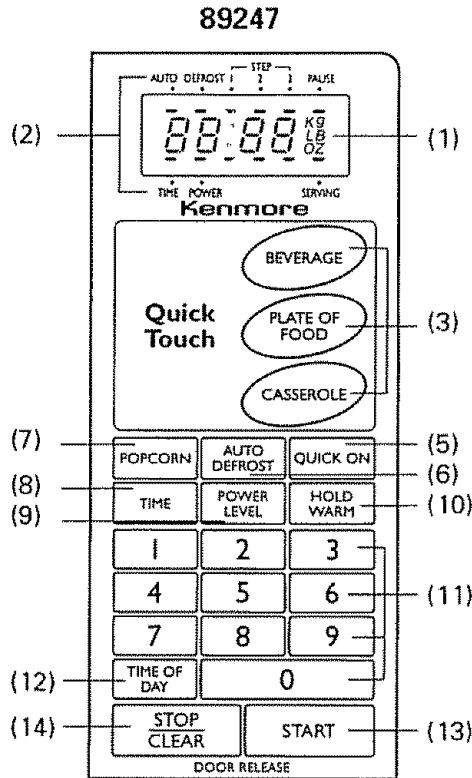

(1) Ventanilla de Indicaciones

Cuenta en segundos de forma regresiva el tiempo de cocinado programado mientras esta en uso. Enseña la hora cuando el horno no esta en uso.

(2) Indicadores

STEP1/ STEP2/ STEP3:

Indicadores de cocinado.

AUTO/ DEFROST/ PAUSE:

Modalidad de cocinado.

TIME/ POWER/ SERVING/ LB/ oz : Una luz destellante indica cuándo seleccionar el tiempo de cocinado, selección de potencia, el peso de la comida, o el número de porciones.

Botones del menú para acción rápida

(3) Botones del menú para recalentar (Página 17)

(4) Botones del menú para comidas congeladas (Página 18) [Sólo 89380/89381]

Botones del menú automatico

(5) QUICK ON (Cocinando rápidamente) (Página 15)

(6) AUTO DEFROST (Descongelador automático) (Página 16)

(7) POPCORN (Palomitas de maíz) (Página 15)

(8) TIME (Botón del tiempo) (Página 19)

(9) POWER LEVEL (Botón del nivel de poder) (Página 19)

(10) HOLD WARM (Botón para mantener el calor) (Página 20)

(11) Botones de números

(12) TIME OF DAY (Hora del día) (Página 14)

(13) START (Botón para iniciar)

(14) STOP/CLEAR (Botón para parar o borrar)

Borra todos los comandos previos si se presiona antes de comenzar a cocinar.

Mientras el horno este en uso presione una vez para parar, y dos para parar y borrar los comandos previos.

Sonido de zumbido



Habrà un sonido cuando algùn botòn del panel de controles sea presionado para indicar que una función ha sido programada.



AJUSTANDO EL RELOJ

Cuando el horno se enchufa por primera vez o cuando la electricidad vuelva después de ser desconectada, los números del reloj leerán **0:00**. Ajuste el reloj.

Ejemplo Para ajustar a 3:15 :

1.  Presione **TIME OF DAY**.
2.  Presione **3, 1, y 5**.
3.  presione **TIME OF DAY**.
El reloj empieza a contar.

Recuerde

- Si el reloj (o indicación) enseña alguna anomalía, desconecte el horno de la salida de corriente CA. Conéctelo nuevamente y reajuste el reloj.

SEGURO CONTRA NIÑOS

Su horno tiene una función de seguridad para prevenir el uso accidental del horno por un niño.

Si el horno es accidentalmente programado para cocinar, el horno no se conectará cuando esta función haya sido programada.

Para Programar:

1. Presione **TIME OF DAY**.
2. Presione **9** cuatro veces.
3. Presione **START**.

El indicador **L** se prenderá y la indicación del reloj reaparecerá

Para Cancelar:

1. Presione **TIME OF DAY**.
2. Presione **7** cuatro veces.
3. Presione **START**.

El indicador **L** desaparecerá y la indicación del reloj reaparecerá.

PALOMITAS DE MAÍZ AUTOMATICAMENTE

Esta función le permite cocinar una bolsa de palomitas de maíz de 3.5 oz (100g) preempacadas para el microondas de manera fácil y rápida.

Recomendaciones para cocinar Palomitas de maíz

- La bolsa de las palomitas de maíz debe de estar a temperatura ambiente.
- Coloque solamente una bolsa en el horno a la vez. Siga las instrucciones en el paquete. No incremente la cantidad.
- Artículos para felicitar el cocinado de las palomitas no son recomendables para usarse con esta función.

Ejemplo

Para cocinar una bolsa de palomitas para microondas de 3.5 oz (100 g) :

1.



Presione **POPCORN**.
La indicación enseña el tamaño de la bolsa.

2.



Presione **START**.
Las palomitas comenzarán a tronar, y la indicación contará el tiempo para cocinarse.

Recuerde

- Si el tamaño de la bolsa no es de 3.5 oz (100 g) siga las instrucciones del fabricante y no use esta función.
- No deje el horno desatendido mientras las palomitas se cocinan.
- Recuerde de supervisar a los niños cuidadosamente.

PRECAUCIÓN

- Después de cocinar abra la bolsa cuidadosamente. Las palomitas y el vapor están extremadamente calientes.
- No recaliente el maíz que no haya tronado, o reuse la bolsa. El sobrecalentamiento puede incendiar el horno.
- Nunca utilice una bolsa de papel café para cocinar las palomitas.

COCINANDO RÁPIDAMENTE (QUICK ON)

QUICK ON es un botón para ahorrar tiempo. Este control simplificado le permite una programación rápida y poder comenzar a cocinar sin tener que tocar el botón **START**.

Se puede escoger una de las nueve selecciones de tiempo de cocinado preprogramadas (1 a 9 minutos) para cocinar a la máxima potencia (**HI**) del microondas. Un diagrama para cocinar con Quick On aparece en la página 31.

Ejemplo

Para ajustar Quick on y cocinar en dos minutos:

1.



Presione **QUICK ON**.

2.



Presione **2**.
El horno comenzará a cocinar y la indicación contará el tiempo para cocinar.

Recuerde

- Puede abrir la puerta para dejar de cocinar antes de que el tiempo programado se acabe. Para comenzar otra vez, cierre la puerta y presione **START**.

DESCONGELADO AUTOMÁTICO POR PESO

La función para Descongelar Automáticamente por peso es un método preciso para descongelar comida congelada que pesa hasta 5.9 libras. El menú selecciona automáticamente 1 libra. Si la comida pesa más o menos de una libra, programe el horno de acuerdo al peso utilizando los botones de números.

Pausa
Esta función contiene un mecanismo preprogramado de pausa que permitir revisar, voltear o separar la comida. El horno está programado para parar al final del primer período de descongelado (aprox. 1/4 del tiempo total de descongelado). Si la puerta del horno no se abre durante la pausa, el horno volverá a conectarse después de 5 minutos.

Un diagrama del descongelador automático (Automatic Defrost Chart) aparece en la página 32.

Para la descongelación manual usando el Tiempo de Cocinado vea la página 19.

Recomendaciones para descongelar

- Revise la comida durante la descongelación.
- Remueva la comida congelada de su paquete de papel o plástico original. Cuando sea difícil separarla del empaque, sepárela cuando este en pausa.
- Coloque las comidas en un plato compatible con el microondas o una parrilla para rostizar para el goteo.
- La comida debe de estar algo congelada en el centro cuando sea removida del horno.
- El menú para el Descongelado Automático incluye el tiempo de pausa.

Ejemplo Para descongelar 1.2 libra de piezas de pollo:

1.  Presione **AUTO DEFROST**.

2.   Coloque el peso presionando 1 y 2.

3.  Presione **START**.
4. El horno se para automática durante la pausa. Separe, reorganize, o voltee la comida.

5.  Presione **START**.

Recuerde

- El menú automáticamente selecciona una libra si el peso no ha sido programado.
- Para programar un peso que sea menor de una libra siempre presione 0 primero. Por ejemplo, para programar 0.2 lb. presione 0 y después 2.
- Solamente un número puede ser programado después de un punto decimal. Si está en duda convierta el número mas bajo.

Onzas	Décimas de una libra
1 - 2	0.1
3 - 4	0.2
5	0.3
6 - 7	0.4
8	0.5
9 - 10	0.6
11 - 12	0.7
13	0.8
14 - 15	0.9

ACCION RAPIDA PARA RECALENTAR

Botones para las funciones de bebidas (BEVERAGE), platos de comida (PLATE OF FOOD), y cacerola (CASSEROLE) se encuentran en el tablero de controles del horno. Estos botones permiten recalentar de una a tres porciones de comidas a la temperatura del cuarto (o del refrigerador, pero no congeladas) de forma automática. Simplemente presione el botón apropiado, una vez para cada porción y después presione **START**.

Recomendaciones para recalentar:

- La comida debe de estar a la temperatura del cuarto o del refrigerador.
- Siga las intrucciones incluidas en el diagrama.
- Cuando recaliente comida, coloque la comida más grande y densa cerca de la orilla del plato.
- Después de recalentar mueva la comida.

Ejemplo Para recalentar dos tazas de sopa:

1.

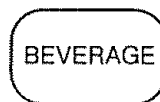

2 veces

Presione **BEVERAGE** dos veces.

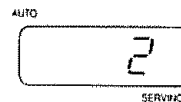

Programa el número de porciones

Presione el botón	Para recalentar
una vez	1 porción
dos veces	2 porciones
tres veces	3 porciones

2.



Presione **START**. El recalentamiento comienza. La indicación enseñará el tiempo restante para la recalentación.

Artículo	Cantidad	Direcciones
Bebidas Café/te Sopa Chocolate Caliente	1 taza (8 oz o 230 ml)	No lo cubra. Bata después de recalentar. Cúbrala. Bata después de recalentar. No lo cubra. Bata después de recalentar.
Platos de Comida	1 porción (8 oz o 230 g)	Cúbralo con papel de cera. Para recalentar de 2 a 3 porciones colóquelas en un plato grande.
Cacerolas	1 taza (6 oz o 170 g)	Cúbralo. Déjelo reposar por 5 minutos.

NOTA: Utilice sólo tazas, platos, o cacerolas hechos para su empleo en el microondas.

ACCION RAPIDA PARA COCINAR COMIDA CONGELADA

[Sólo 89380/89381]

Los botones FROZEN DINNER (cena congelada), FROZEN ENTREE (plato congelado), FROZEN VEGETABLES (vegetales congelados) están colocados en el tablero de controles en el horno de microondas. Utilice estos botones para descongelar y calentar comidas congeladas empacadas. El horno automáticamente determina el tiempo y nivel de poder requerido para cada artículo congelado según la programación que usted coloque.

Recomendaciones para la comida congelada

- Siga las instrucciones para remover o ventilar el empaque, perforar la bolsa, reemplazar el aluminio por plástico, etc.
- Para mejores resultados, use esta función con comidas que estén empacadas en bolsas individuales en lugar de dos o más.
- Para los mejores resultados, cambie las comidas congeladas de recipientes de aluminio a recipientes compatibles con el microondas.
- Comidas congeladas con empaques especiales para dorar como pizza, papitas, y sandwiches cerrados deben cocinarse según las direcciones del fabricante. Póngalos en un plato compatible con el microondas.

Ejemplo

Para calentar una comida congelada de 11 oz (310 g):

1.



2 veces

Presione FROZEN DINNER dos veces.

AUTO

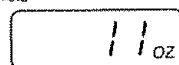

Se puede programar el peso de la comida por medio de presionar el botón del menú deseado, como es demostrado en el diagrama.

Peso recomendado de los alimentos

Toque el botón	una vez	2 veces	3 veces
FROZEN DINNER	7 oz	11 oz	15 oz
FROZEN ENTREE	6 oz	9 oz	20 oz
FROZEN VEGETABLES	5 oz	10 oz	20 oz

2.



Presione START.

Se iniciará el cocinado. La indicación contará el tiempo de cocinado.

Recuerde

FROZEN DINNER con postres

- Remueva el postre del empaque si las direcciones lo recomiendan

FROZEN ENTREE para entremeses como macaronies con queso, pure de papa, arroz o pasta:

- Coloque un plato compatible con el microondas debajo del paquete si el paquete contiene queso que podría derramarse durante el calentamiento (como, por ejemplo, macarrones con queso).

FROZEN VEGETABLES

- Siga las direcciones del paquete para añadir agua, perforar la bolsa, cocinar en un plato, ventilar el paquete, etc.

TIEMPO DE COCINADO

Este método básico para cocinar con el horno de microondas permite cocinar la comida por el tiempo deseado. Aparte del nivel de potencia máxima, **HI POWER** se puede seleccionar de 9 niveles de poder, 1 (10% de la potencia total) hasta 9 (90% de la potencia total) para las comidas que requieren ser cocinadas más lentamente. El horno también contiene 0 (nada de potencia).









Comidas con altas cantidades de humedad deben de ser cocinadas con la máxima poder, ya éste es el modo más rápido y mantiene mejor la textura y sabor de las comidas.

Para comprobar el nivel de potencia mientras el horno este en uso, simplemente oprima **POWER LEVEL**. El nivel de potencia aparece en la ventanilla de indicaciones

Descongelando Manualmente

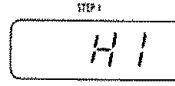
Para descongelar manualmente (sin usar las funciones del descongelador automático) utilice el nivel de potencia 3. Para apresurar el descongelamiento de comidas densas de más de 1 libra (450 g), se puede comenzar en **HI** por tres minutos y después reducir al nivel 3.

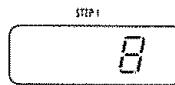
Ejemplo: Para cocinar en el nivel 8 por 40 segundos:

1.  Oprima **TIME**.
2.   Programe 40 segundos presionando el 4 y el 0.
3.  Oprima **POWER LEVEL**. 
4.  Oprima 8 para seleccionar el nivel 8. La indicación enseña 8. 
5.  Oprima **START**.

Recuerde

- El tiempo para cocinar puede ser programado hasta 99 minutos y 99 segundos.
- Cuando cocine en el nivel HI, no efectue los pasos 3 y 4.

GUIA PARA LOS NIVELES DE POTENCIA

Nivel de Potencia	Ejemplos de Cocinado
1	<ul style="list-style-type: none"> • Ablandar queso crema • Mantener cacerolas y guisados calientes.
2	<ul style="list-style-type: none"> • Ablandar chocolate y clarificar mantequilla • Calentar panes, tortas, tacos, tortillas y pan francés • Calentar poca comida. Descongelar carne, pollo o pescado.
3	<ul style="list-style-type: none"> • Completar el ciclo de cocinar de cacerolas, guisados y algunas salsas • Descongelar manualmente • Deshelar carne, aves y mariscos.
4	<ul style="list-style-type: none"> • Cocinar piezas de carne no tan suaves en líquidos. o platillos que se cocinen despacio • Completar el ciclo de cocinar de postres no tan suaves.
5	<ul style="list-style-type: none"> • Cocinar guisados y sopas después de hervir • Cocinar flan y pastas • Cocinar asados, jamón, ternera y cordero.
6	<ul style="list-style-type: none"> • Cocinar huevos revueltos. Cocinar pasteles.
7	<ul style="list-style-type: none"> • Cocinar platillos con queso, huevos y leche.
8	<ul style="list-style-type: none"> • Recalentar rápidamente comidas ya preparadas.
9	<ul style="list-style-type: none"> • Cocinar cebollas, apio, y pimientos rápidamente • Recalentar rebanadas de carne rápidamente.
HI	<ul style="list-style-type: none"> • Cocinar pollo, pescado, vegetales y la mayoría de guisos • Precalentar un platillo que debe de dorarse. Hervir agua.

CONSERVANDO EL CALOR

Hold Warm mantiene la comida caliente hasta por 100 minutos después de que un programa de cocinar se haya completado o hasta que la puerta se abra, o **STOP/CLEAR** se oprima. HOLD aparecerá en la indicación.

También se puede usar Hold Warm sin tener que usar un programa para cocinar.

1.



Oprima **HOLD WARM**.

2.

Programe el programa para cocinar deseado.

3.



Oprima **START**. Después del programa de cocinado, HOLD aparecerá en la indicación.

ALARMA POR MINUTO

La alarma se puede utilizar para otros propósitos aparte del de cocinar.

Ejemplo

Prográmelo por 3 minutos para llamar por teléfono:

1.



Oprima **TIME**.

2.



Oprima 3, 0, y 0.

3.



Oprima **POWER LEVEL**.

4.



Oprima 0 (nivel de poder 0).

5.

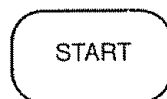

Oprima **START**.

COCINANDO EN ETAPAS MÚLTIPLES

Usted puede programar hasta 3 etapas de cocinado en secuencia. El descongelador automático se puede programar para la primera etapa para descongelar y después cocinar.

- Para programar 2 ó 3 etapas de cocinado, repita los pasos del 1 a 4 de la página anterior y oprima **START**.
- Utilizando la alarma para la primera etapa, se puede dilatar el tiempo para empezar a cocinar hasta por 99 minutos y 99 segundos.

Español

QUESTIONS AND ANSWERS

OPERATION

- Q. What is wrong when the oven light does not glow?
- A. There may be several reasons why the oven light does not glow. Perhaps:
- Door is not closed and locked. Push firmly to be sure that door is locked properly.
 - The light bulb has burned out.
- Q. Why is steam coming out of the air exhaust vent?
- A. Steam is normally produced during cooking. The microwave oven has been made to vent this steam.
- Q. Can the microwave oven be damaged if it operates empty?
- A. Yes. Never operate while empty or without the turntable positioned correctly on the roller rest.
- Q. When the oven is plugged into a wall outlet for the first time, it might not work properly. What is wrong?
- A. When the oven is plugged in for the first time or when power resumes after a power interruption, the microcomputer used in the oven control may temporarily become scrambled and fail to function as programmed. Unplug the oven from the wall outlet and then plug it back in. The microcomputer will then reset for proper functioning.
- Q. Why do I see light reflection around the outer case?
- A. This light is from the oven light located outside the oven cavity.
- Q. Why is there noise coming from the turntable when the oven is turned on?
- A. This noise occurs when the turntable roller rest and cavity bottom are dirty. Frequent cleaning of these parts should eliminate or reduce the noise.
- Q. Instructions for aluminum foil use are confusing. When should I use foil?
- A. It should be used to shield portions of food from becoming overcooked or overdefrosted. Use small flat pieces of foil for shielding.

FOODS

- Q. What is wrong when baked foods have a hard, dry brown spot?
- A. This is caused by overcooking. Shorten cooking or reheating time.
- Q. Why do eggs sometimes pop?
- A. The egg yolk may pop because of steam build-up inside the membrane. To prevent this, simply pierce the membrane with a toothpick before cooking it.
- CAUTION: Never microwave eggs in the shell since they may explode.**
- Q. Why are scrambled eggs sometimes a little dry after cooking?
- A. Eggs dry out if they are overcooked. You may need to vary the cooking time for one of these reasons:
- Eggs vary in size.
 - Eggs are at room temperature one time and at refrigerator temperature another time.
 - The shapes of utensils vary, which makes it necessary to vary cooking time.
 - Eggs continue cooking during standing time.
- Q. What is wrong when three potatoes bake thoroughly and the fourth one is still not cooked?
- A. The fourth potato may be slightly heavier than the others and should be cooked 30 to 60 seconds longer. Remember to allow one inch (2.5 cm) around each potato when baking. For more even cooking, place potatoes in a circle.
- Q. Why do baked apples sometimes burst during cooking?
- A. The peel has not been removed from the top half of each apple to allow for expansion of the interior of the apple during cooking. As in regular cooking methods, the interior of the apple expands during the cooking process.
- Q. How are boil-overs avoided?
- A. Use a larger utensil than usual for cooking. If you open the oven door or touch **STOP/CLEAR**, the food will stop boiling.
- Q. Why does the dish become hot when I microwave food in it?
- A. As the food becomes hot it will conduct the heat into the dish. Use hot pads to remove food after cooking.

CLEANING

Wipe the oven inside and outside with a soft cloth and a mild detergent solution. Then rinse and wipe dry. This should be done on a weekly basis - more often if needed. Never use cleaning powders or rough pads. Excessive oil splatters on the inside top will be difficult to remove if left for many days. Wipe splatters with a wet paper towel, especially after cooking chicken or bacon.

- The turntable may be cleaned at the sink. Be careful not to chip or scratch the edges as this may cause the turntable to break during use.
- The turntable roller rest should be cleaned regularly.

SPECIAL CARE

For best performance and safety, the inner door panel and the oven front frame should be free of food or grease buildup. Wipe them often with a mild detergent. Then rinse and wipe dry. Never use cleaning powders or rough pads.

After cleaning the control panel, touch **STOP/CLEAR** to clear any entries that might have been entered accidentally while cleaning the panel.

REMOVABLE PARTS

The following parts may be removed as described. They should be washed in warm (not hot) water with a mild detergent and a soft cloth. Once they are clean, rinse them well and dry with a soft cloth. Never use cleaning powders, steel wool or rough pads.

BEFORE CALLING FOR SERVICE

You can often correct operating problems yourself. If your microwave oven fails to work properly, locate the operating problem in the chart below and try the solutions marked for each problem.

If the microwave oven still does not work properly, contact the nearest authorized service center.

PROBLEMS

Oven will not start	X	X	X							
Err displays				X						
Arcing or sparking					X				X	
Incorrect time									X	
Unevenly cooked foods					X	X		X		X
Overcooked foods								X		
Undercooked foods					X	X	X	X		
Improper defrosting					X			X		X

POSSIBLE CAUSES

- Is power cord plugged in?
- Is door closed?
- Cooking time not set.
- Touch **STOP/CLEAR**.
- Use microwave-safe cookware only.
- Completely defrost food.
- Turn or stir food.
- Reset clock.
- Do not operate with oven empty.
- Use correct time/cooking power level.
- Check to see that oven ventilation ports are not restricted.

COOKING TECHNIQUES

Advantages of microwave cooking are speed and efficiency. For warming, heating, and defrosting, nothing compares. There are a few tips that will make microwaving easier and more enjoyable.

Microwave Cooking Principles

Because microwave cooking requires only one-quarter to one-third the time of conventional cooking, the same cooking principles become even more important.

Quantity

The more food being cooked, the longer you will have to cook it. As a general rule, when doubling a recipe, increase the cooking time by about 50 percent. When cutting a recipe in half, reduce the time by about 40 percent.

Density

Dense foods, such as potatoes, roasts and carrots, absorb microwave energy less quickly than porous foods such as ground beef or mashed potatoes. Therefore, denser foods take longer to cook.

Shape and Size

Small pieces cook faster than large ones. For even cooking, it is important to have all the pieces the same size. Evenly shaped pieces, round or doughnut shaped, microwave best. When cooking items of varying thickness, arrange the thick portion near the outer edge of the dish.

Moisture, Sugar and Fat

Food high in moisture, sugar or fat cook faster than foods that are low in these substances. Add a minimum of liquid to moist foods. An excess amount of water slows cooking.

Starting Temperature

Frozen or refrigerated foods take longer to microwave than food at room temperature.

Delicate Ingredients

Some foods require special attention when cooked in the microwave oven. Delicate foods such as eggs, cheese, mayonnaise, etc. cook so quickly, they should be watched carefully.

Microwave Cooking Techniques

Arranging: Arrange foods in a circular pattern, when possible.

Piercing: Pierce the membrane of foods such as eggs, oysters, snails, sausages, livers, clams and whole vegetables, so they do not burst.

Covering: Covering speeds heating and prevents spattering.

Stirring: To help food cook more quickly and evenly.

Turning Over: To help larger foods such as roasts or whole chickens cook more evenly.

Reheating: Place food that is denser/larger/thicker to the outer edge and the smaller/thinner or more porous food to the center.

Shielding: To prevent overcooking, thin or bony areas can be protected with small strips of aluminum foil.

Standing Time: Foods continue cooking even after removal from the oven. Standing time is necessary to allow foods to complete cooking.

Defrosting

The microwave's ability to defrost is one of its most appreciated features. Many of the same principles and techniques that apply to microwave cooking also apply to microwave defrosting.

Converting Recipes

Microwave recipes will likely call for less liquid and cooking time.

Microwave Thermometers

For best results, a microwave-safe thermometer can be carefully and properly inserted into the food. The guide to internal temperatures gives suggested thermometer readings for meat and poultry. Keep in mind that standing time is essential for most food to reach its proper serving temperature.

Guide to Internal Temperatures

130°F (54°C)	Rare beef
140°F (60°C)	Medium beef
150°F (66°C)	Vegetables, hot drinks, soups, casseroles
155°F (68°C)	Veal
160°F (71°C)	Fish steaks and fillets
165°F (74°C)	Well done lamb, pork
170°F (77°C)	Poultry parts, whole fish, Well done beef

APPETIZERS

CONVERTING RECIPES

Most hot appetizers adapt well to microwave cooking, the exception being those wrapped in pastry. Pastry requires the hot environment of the conventional oven to become crisp.

- Toppings for canapés can be made ahead and then placed on bread or crackers just before heating. This guarantees a crispness.
- Cover appetizers or dips only when called for by a recipe. Use casserole lids, wax paper, plastic wrap, or paper towel.
- Appetizers and dips that contain cheese, mayonnaise and other delicate ingredients are usually heated on power level 1. A higher setting might cause separation or drying.

Reheating Guide - Convenience Appetizers

Item	Amount	Power	Approx. Cooking Time	Special Notes
Meat spread	4 oz (115 g)	8	1 - 1½ min.	Transfer to small microwave-safe bowl.
Cocktail franks	4 servings	7	½ - 1 min.	Place on paper towel. Cover with wax paper.
Cooked pizza, 10 inches, cut into 8 portions	1 wedge	8	½ - 1 min.	Place on paper towel or paper plate or leave in uncovered cardboard box, points toward center.
	4 wedges	8	1½ - 2½ min.	
	Whole	8	3 - 4 min.	
Dips, cream	½ cup (125 mL)	1	2 - 3 min.	Cover with wax paper.
Egg rolls	12 (6 oz - 170 g)	7	1 - 1½ min.	Place on paper towel or paper plate.
Mini Tacos	4 - 6 (6 oz - 170 g)	5	1 - 1½ min.	Place on paper towel or paper plate.

Cooking Guide – Hot Drinks

Item	Amount	Power	Approx. Cooking Time	Special Notes
Water	6 oz (170 mL) cup, 1	HI	1¼ - 1¾ min.	For instant coffee, soup, tea, etc.
	6 oz (170 mL) cup, 2	HI	2 - 3 min.	
	8 oz (230 mL) cup, 1	HI	1½ - 2¼ min.	
	8 oz (230 mL) cup, 2	HI	3 - 4 min.	
Milk	6 oz (170 mL) cup, 1	7	1 - 2 min.	For hot chocolate, etc.
	6 oz (170 mL) cup, 2	7	2 - 3 min.	
	8 oz (230 mL) cup, 1	7	2 - 2½ min.	
	8 oz (230 mL) cup, 2	7	3 - 4 min.	

SOUPS AND SANDWICHES

A large variety of sandwich combinations can be made in your microwave oven. Because sandwiches heat quickly, be careful not to overcook them — the bread can become tough and chewy. Heat breads until warm, not hot, and cheese until it just begins to melt. Let the following tips guide you when adapting or creating your own sandwiches.

CONVERTING SANDWICH RECIPES

- Heat sandwiches on white paper towels or paper plates. To prevent splattering, as well as to absorb steam and prevent sogginess, you can wrap each sandwich in a paper towel. Remove wrapping immediately after warming. It takes less than 1 minute to heat most sandwiches. Heat on power level 8.

- Thinly sliced meat heats better than thickly sliced meat. The slower-cooking thick slices often cause the bread to overcook before the meat is hot.

CONVERTING SOUP RECIPES

- When cooking canned soups, remove from can. Use microwave-safe dish. Add milk or water as directed on can. Cover dish.
- Stir cream-style soup halfway through cooking time. Let stand, covered, 3 minutes before serving.

Cooking Guide – Canned Soups

Item	Amount	Power	Approx. Cooking Time
Broth	10¼ oz (290 mL)	8	3½ - 4 min.
Cream-style	10¼ oz (290 mL)	8	4 - 5 min.
Tomato	10¾ oz (300 mL)	8	5 - 8 min.
Bean, pea, or mushroom	10¾ oz (300 mL)	7	5½ - 7 min.
Undiluted chunk-style vegetable	10¾ oz (300 mL)	8	2 - 3½ min.
	19 oz (540 mL)	8	4 - 6 min.

Cooking Guide - Quick Soups

Item	Amount (number of envelopes)	Power	Approx. Cooking Time
Cup of Instant soup 1¼ oz (35 g) envelope	1	HI	1 - 1½ min.
	2	HI	2 - 2½ min.
	4	HI	4 - 5 min.

VEGETABLES AND RICE

Fresh Vegetables

Spread out cut vegetables in a shallow microwave-safe dish. Add water as recommended in chart. Add salt to water or salt after cooking. Whole vegetables such as potatoes, squash or eggplant should be pierced and arranged in a circular pattern with heavier ends pointing towards the outer edge of dish. Cook covered. Halfway through cooking, stir, rearrange and/or turn vegetables over. Let stand, covered. Whole vegetables should stand 10 minutes and cut vegetables 5 minutes.

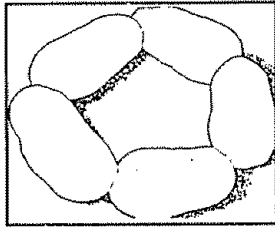

Frozen Vegetables

Remove frozen vegetables from package (10 oz / 280 g) and place them in a microwave-safe casserole.

Cook covered on **HIGH** 3 - 5 minutes. Stir once during cooking. Let stand covered a few minutes.

Add 2 tablespoons (30 mL) of water to frozen artichokes, brussels sprouts, okra and peas and $\frac{1}{2}$ cup (125 mL) water plus 1 tablespoon (15 mL) butter or margarine to frozen lima beans.

Frozen Vegetables in a Pouch

Remove pouch from package, and place on a microwave-safe plate. Pierce one hole in pouch.

Fresh Vegetables Cooking Chart

Cook on **HIGH** power. (All weights in the chart are the purchase weights before peeling and trimming.)

Vegetable	Amount	Water	Approx. Cooking Time
Asparagus, spears	1 lb (450 g)	2 tbsp (30 mL)	3 - 4 min.
Beans, green or wax, cut in pieces	1 lb (450 g)	$\frac{1}{4}$ cup (50 mL)	4 - 6 min.
Broccoli, cut in pieces	1 lb (450 g)	$\frac{1}{4}$ cup (50 mL)	3 - 4 min.
Brussels sprouts	10 oz (280 g)	$\frac{1}{4}$ cup (50 mL)	2 - 4 min.
Cabbage, shredded	1 lb (450 g)	$\frac{1}{4}$ cup (50 mL)	5 - 6 min.
Carrots, sliced or diced	1 lb (450 g)	2 tbsp (30 mL)	4 - 5 min.
Cauliflower, chopped	1 medium	$\frac{1}{4}$ cup (50 mL)	3 - 5 min.
Corn, on the cob	1 ear 2 ears 4 ears	none none none	2 - 4 min. 5 - 7 min. 10 - 12 min.
Mushrooms, sliced	$\frac{1}{2}$ lb (230 g)	2 tbsp (30 mL)	2 - 4 min.
Peas, green, shelled	1 lb (450 g)	$\frac{1}{4}$ cup (50 mL)	5 - 7 min.
Potatoes, white, baking, 6 - 8 oz (170 - 230 g) each. Pierce skin.	1 2 4	none none none	4 - 8 min. 7 - 11 min. 12 - 15 min.
Potatoes, red, boiling	3	$\frac{1}{4}$ cup (50 mL)	7 - 8 min.
Spinach, leaf	1 lb (450 g)	none	3 - 5 min.
Squash, pierce with fork	1 $\frac{1}{2}$ lb (680 g)	none	8 - 10 min.
Zucchini, sliced	1 lb (450 g)	$\frac{1}{4}$ cup (50 mL)	5 - 7 min.

Cooking Guide - Rice

Item	Water	Power	Approx. Cooking Time	Special Notes
Long grain. 1 cup (250 mL)	2 cups (500 mL)	3	20 - 25 min.	Use 3-quart (3 L) microwave-safe casserole. Heat water 4 to 7 min. to boil. Add rice, salt and butter or margarine. Cover tightly. Let stand 5 minutes.
Short grain. 1 cup (250 mL)	1 $\frac{1}{2}$ cups (375 mL)	3	22 - 27 min.	
Wild rice, brown rice, 1 cup (250 mL)	2 cups (500 mL)	3	35 - 45 min.	

MEATS, POULTRY AND FISH

PREPARATION

Use a microwave-safe baking dish, casserole, etc. to cook meat, poultry and fish.
 Frozen meat, poultry and fish should be completely thawed.
 Wash poultry and fish in cool water.
 Arrange small items in a single layer in dish and avoid overlapping edges of food.
 Place thick sections toward edge of the dish.
 Use a rack in the dish to elevate meat out of the juices.

Use spices and seasonings as desired.
 Add salt after cooking if necessary.
 Kitchen bouquet with butter may be used to obtain "cooked" color of meats and poultry.
 Aluminum foils can be used to cover thin parts of meat or poultry wings and legs to prevent overcooking. Foils should be applied toward the end of cooking time. Place meat fat side down.

COOKING

Use wax paper or plastic wrap to stop splattering.
 Turn over or rearrange meat, poultry and fish halfway through cooking time

CHECKING DONENESS

Beef: The color inside meat indicates doneness. Rare roast should be red inside. Medium is pink and gray indicates well done.
Pork: Cooked pork meat should be gray with clear juice.
Poultry: Juices should be clear yellow when cooked. Legs should move freely.
Fish and Seafood: Should be opaque in color and flake easily.

To check internal temperature of various meats and poultry, use a microwave or conventional meat thermometer after removing meat from the oven. Insert the thermometer avoiding bone or fat. Lower temperatures are found in the center of the roast or in the muscle close to a large bone.
Never use a conventional meat thermometer in the microwave oven.

Return undercooked food to oven for a short period of time at the recommended power level. Let stand as recommended in chart. Cover roasts and whole poultry during stand time.

Food	Power	Approx. Cooking Time	Stand Time	Special Notes
Beef				
Hamburgers, refrigerated 4 oz (115 g) each				Cook in a shallow dish. Cover loosely with wax paper. Turn over halfway through cooking
1	HI	1 - 1½ min.	2 min.	
2	HI	1½ - 2½ min.	2 min.	
4	HI	3 - 5 min.	2 min.	
Hamburgers, frozen 4 oz (115 g)				
1	HI	2 - 3 min.	2 min.	
2	HI	4 - 6 min.	3 min.	Turn over and separate halfway through cooking.
4	HI	7 - 9 min.	3 min.	
Meat loaf 1½ lb (680 g)	5	15 - 20 min.	5 min.	Arrange in loaf dish. Cover with wax paper.
Roasts, tender 1 lb (450 g)				Cover with wax paper. Shield halfway through cooking and turn roast over if necessary. Stand tented with foil. *Approx. temp. after stand Rare 130°F (54°C) Medium 140°F (60°C) Well done 170°F (77°C)
Rare	5	7 - 9 min.	10 to 15 min.	
Medium	5	9 - 11 min.	10 to 15 min.	
Well done	5	11 - 14 min.	10 to 15 min.	

*Check with conventional meat thermometer.

MEATS, POULTRY AND FISH (CONT.)

Food	Power	Approx. Cooking Time	Stand Time	Special Notes
Pork Chops, loin ½ inch (1 cm) thick, 7 oz (200 g) each				Place in a shallow dish. Cover loosely with wax paper. Turn over at halfway through cooking time.
1	HI	1½ - 2 min.	2 min.	
2	HI	3½ - 4½ min.	3 min.	
4	HI	6 - 8 min.	3 min.	
Pork roast, 1 lb (450 g)	5	12 - 14 min.	10 to 15 min.	Cover with wax paper. Shield halfway through cooking and turn roast over if necessary. *Approx. temp. after stand 170°F to 175°F (77°C to 79°C)
Ham, precooked canned 3 lb (1.4 kg)	5	10 - 14 min.	10 min.	Shield edge of ham with strip of foil. Place on roasting rack. Cover with wax paper. Turn over halfway through cooking. *Approx. temp. after stand 120°F to 130°F (50°C to 55°C)
Ham, slice 1 inch (2.5 cm) thick, 1 lb (450 g)	HI	6 - 8 min.	5 min.	Cover with wax paper. Turn over halfway through cooking.
Sausage links, fresh 1 - 2 oz (30 - 55 g) each				Pierce before cooking. Cover with wax paper. Turn over once.
2	HI	½ - 1½ min.	1 min.	
4	HI	1 - 2 min.	1 min.	
Sausage links, frozen, precooked brown and serve ¾ oz (20 g) each				
2	HI	½ - 1¼ min.	1 min.	
4	HI	1 - 2 min.	1 min.	
Wieners, 2 oz (55 g) each				Score before cooking.
1	HI	¼ - ¾ min.	1 min.	
2	HI	½ - 1 min.	1 min.	
4	HI	1 - 2 min.	1 min.	
Bacon, slices				Cook on bacon rack or line bottom of dish. Place bacon on paper towel. Cover loosely with another paper towel. Do not turn over bacon.
1	HI	1 - 1¾ min.	1 min.	
2	HI	1¼ - 2¼ min.	1 min.	
4	HI	2½ - 4 min.	1 min.	
Lamb Chops, shoulder ½ inch (1 cm) thick				Cover loosely with wax paper.
1	HI	1 - 2 min.	2 min.	
2	HI	3 - 4 min.	5 min.	

*Check with conventional meat thermometer.

MEATS, POULTRY AND FISH (CONT.)

Food	Power	Approx. Cooking Time	Stand Time	Special Notes
Poultry Chickens, whole, up to 4 lb (1.8 kg) 1 lb (450 g) Cornish hens 1 lb (450 g)	HI HI	5 - 8 min. 4 - 7 min.	10 min. 10 min.	Place breast-side down on a roasting rack in a dish. Cover with plastic wrap or wax paper. Turn over halfway through cooking. Stand tented with foil. When cooked, internal temperature should be 180°F (82°C) and juices should run clear.
Chicken pieces, up to 2 lb (900 g) 1 lb (450 g)	HI	6 - 8 min.	5 min.	Arrange skin-side up in a baking dish halfway through cooking. meatier portions toward edge of dish. Cover with plastic wrap or lid.
Fish and Seafood Fish fillets, ¾ lb (340 g) Fish steaks 2, 6 oz (170 g) each Scallops 1 lb (450 g) Shrimp, medium size, shelled and cleaned, 1 lb (450 g) Whole fish, stuffed or unstuffed 1½ to 1¾ lb (680 - 800 g)	HI 5 7 7 HI	3 - 5 min. 6 - 8 min. 4 - 6 min. 4 - 6 min. 6 - 9 min.	3 min. 5 min. 3 min. 3 min. 5 min.	Arrange in a single layer in dish. Cover with wax paper. Rearrange or stir shrimp or scallops halfway through cooking.

EGGS

SCRAMBLED EGGS

Break eggs into a microwave-safe glass measure.
 Add 1 tablespoon milk and 1 teaspoon butter for each egg. Beat with a fork.
 Cook at **Power Level 6** according to time in the chart. Stir at least once during cooking time. Let stand 1 minute.

Eggs	Time
1	1 - 1½ min.
2	2 - 2½ min.
3	3 - 4 min.
4	4 - 5½ min.

POACHED EGGS

Use 6-ounce (170 mL) microwave-safe custard cup with ¼ cup (50 mL) water for 1 to 3 eggs. Use 1-quart (1 L) microwave-safe dish with 1 cup (250 mL) water for 4 eggs.
 Heat at **HI POWER** to bring water to a boil with ½ teaspoon salt and up to ¼ teaspoon vinegar. Break egg carefully into hot water. Pierce egg several times lightly with toothpick. Cover with wax paper.
 Cook at **Power Level 5** according to time in the chart. Let stand, covered, 1 minute before serving.

Eggs	Time
1	1 - 1½ min.
2	1½ - 2½ min.
3	2½ - 4 min.
4	3½ - 5 min.

BAKED GOODS AND DESSERTS

Converting Recipes

When adapting quick bread recipes, you will find it necessary to reduce the amount of leavening (baking powder or soda) by about one-quarter the normal amount. A bitter aftertaste is apparent if too much leavening is used in biscuits or muffins. Since food rises higher in the microwave oven, you will not see a loss in volume from the reduction of soda or baking powder.

If a recipe contains buttermilk or sour cream, do not change the amount of soda, since it serves to counteract the sour taste and does not act only as a leavening agent.

When using a mix where leavening cannot be reduced, allow the dough to stand about 10 minutes before cooking in order for some of the gas to be lost.

Breads and rolls should be reheated only until they are warm to the touch. Overheating or overcooking makes bread tough and rubbery.

Cooking/Reheating Guide

Item	Power	Approx. Cooking or Reheating Time	Special Notes
Hamburger buns, hot dog rolls, frozen: 1 lb (450 g) Room temp.: 1 2 4	3 8 8 8	1½ - 3 min. 5 - 10 sec. 10 - 15 sec. 15 - 20 sec	Place on paper plate or wrap in paper towel.
Doughnuts, sweet rolls, muffins 1 2 4	8 8 8	10 - 15 sec. 15 - 20 sec. 30 - 40 sec.	Place on paper plate or towel. Add 15 seconds if frozen.
Whole coffee cake, Frozen: 10 - 13 oz (280 - 370 g) Room temp.: 10 - 13 oz (280 - 370 g)	8 8	1 - 1½ min. ½ - 1 min.	Place on paper plate or towel. Let stand 5 - 10 minutes before serving.
French bread, Frozen: 1 lb (450 g) Room temp.: 1 lb (450 g)	8 8	½ - 1½ min. 20 - 30 sec.	Place on paper plate or towel.
Butter cake 2¼ cups (550 mL) batter 1st stage 2nd stage	5 HI	8 min. 1 - 2 min.	Place on inverted pie plate.
Brownies 2 cups (500 mL) batter	5	11 - 13 min.	Cover with wax paper. Place on inverted pie plate.
Bar cookies 1½ cups (375 mL) batter	5	7 - 9 min.	Cover with wax paper.
Muffins, ¼ cup (50 mL) batter each 1 2 6	7 7 7	40 - 60 sec. 1 - 1½ min. 3 - 4 min.	

QUICK-ON COOKING CHART

Item	Amount	Time	Special Notes
Beverage			
Water-based	1 cup (250 mL)	1 - 2 min.	Heat uncovered.
	2 cups (500 mL)	2 - 3 min.	Stir after heating.
Milk-based	1 cup (250 mL)	1 - 2 min.	
	2 cups (500 mL)	2 - 3 min.	
Soups			
Broth-based	10¾ oz (300 mL) can	2 - 3 min.	Use microwave-safe casserole. Cover.
Cream-based	10¾ oz (300 mL) can	3 - 4 min.	Stir after heating.
Cooked pizza			
10 inches cut in 8 portions	2 wedges	1 - 2 min.	Place on paper towels or paper plate or leave in uncovered cardboard box. Points toward center.
	4 wedges	2 - 3 min.	
	whole	3 - 4 min.	
Meat			
Sliced thin	3 - 5 oz (85 - 140 g)	1 min.	Heat on microwave-safe plate, covered with wax paper.
Sliced thick, 1" (2.5 cm)	3 - 5 oz (85 - 140 g)	1 - 2 min.	
Chili, stews	2 cups (500 g)	3 - 4 min.	Place in microwave-safe dish. Cover. Stir halfway through cooking time.
Hamburgers, meat loaf slices, sausage patties	1 serving	1 min.	Place on microwave-safe plate. Cover with paper towel. Turn over once.
	2 servings	1 - 2 min.	
	4 servings	3 - 4 min.	
Poultry			
Chicken pieces	1	1 min.	Heat on microwave-safe plate. Cover with wax paper. If fried, cover with paper towel.
	2	1 - 2 min.	
	4	2 - 3 min.	
	6	3 - 5 min.	
Chicken, turkey, sliced	3 - 5 oz (85 - 140 g)	1 - 2 min.	Heat on microwave-safe plate. Cover with wax paper.
Seafood			
Shrimp, crab, or scallops in sauce, frozen	6½ oz (185 g)	3 - 5 min.	Slit pouch and place on microwave-safe plate. Flex pouch to mix halfway through cooking time.
Seafood or fish casserole, frozen	16 oz (450 g)	4 - 6 min.	Remove from package to a microwave-safe casserole. Cover. Stir once during cooking.
Cooked rice, pasta			
	¾ cup (175 mL)	1 min.	Heat in microwave-safe casserole, covered with plastic wrap.
	1 - 2 cups (250 - 500 mL)	2 min.	
Vegetable, frozen in pouch	10 - 12 oz (280 - 340 g)	3 - 5 min.	Slit pouch. Place on microwave-safe plate. Flex pouch to mix halfway through cooking time.
Mashed potatoes, instant	4 servings	3 - 5 min.	Follow package directions. Reduce liquid by 1 tbsp (15 mL).
Canned vegetable			
	8 oz (230 g)	1 - 2 min.	Use microwave-safe casserole, covered. Stir once.
	15 oz (425 g)	2 - 3 min.	
	18 oz (500 g)	2 - 4 min.	
Pudding and pie filling mix	3¼ oz (90 g)	4 - 6 min.	Follow package directions. Stir once.
Cereals			
Cream of wheat (regular)	¼ cup (50 mL)	1 - 2 min.	Add ¾ cup (175 mL) of water. Cook uncovered. Stir once. Let stand 1 minute. Add 1½ cup (375 mL) of water. Cook uncovered. Stir once. Let stand 1 minute.
	½ cup (125 mL)	3 - 4 min.	
Wheat-bran cereal	¼ cup (50 mL)	1 - 2 min.	Add ¾ cup (175 mL) of water. Cook uncovered. Stir once. Let stand 1 minute. Add 1½ cup (375 mL) of water. Cook uncovered. Stir once. Let stand 1 minute.
	½ cup (125 mL)	3 - 4 min.	

AUTOMATIC DEFROST CHART

- Set Auto Defrost by Weight according to instructions on page 8.
- Remove food from wrapper and place in a microwave-safe dish.
- Cover thin parts with aluminum foil.
- Use a microwave-safe roasting rack to hold small items, such as chicken pieces, fish, shrimp and scallops.
- Large roasts should be still icy in center. Allow to stand.
- Fish and seafood should also be slightly icy.

Item	Special Notes
Beef	
Ground beef	Turn over and remove defrosted portion at pause.
Liver	Drain liquid as it defrosts. Separate pieces.
Roasts	Turn over at pause. Cover ends with foil.
Sirloin steak	Turn over at pause.
Rib or T-bone	Turn over at pause.
Flank steak	Turn over at pause.
Stewing meat	Break apart at pause.
Pork	
Bacon	Defrost in original wrapper. Turn over at pause. Center should be slightly icy.
Chops	Separate and turn over at pause.
Ribs	Turn over at pause.
Roasts	Turn over at pause. Cover ends with foil.
Lamb	
Chops	Separate and turn over at pause.
Ribs	Turn over at pause.
Roasts	Turn over at pause. Cover ends with foil.
Poultry	
Chicken, whole, up to 3 lb - 2 oz (1.4 kg)	Turn over at pause. Cover ends with foil. Rinse under cold water.
Pieces	Separate halfway through defrost time.
Cornish hens	Turn over at pause. Rinse under cold water.
Fish and Seafood	
Crabmeat, shrimp	Break apart at pause.
Fish fillets	Turn over and rearrange at pause. Rinse under cold water to separate.
Fish whole, steaks	Turn over at pause. Cover head and tail with foil.
Scallops	Break apart at pause. Remove defrosted scallops.

SEARS SERVICE

"WE SERVICE WHAT WE SELL"

"We Service What We Sell" is our assurance to you that you can depend on Sears for service because Sears Service is nationwide.

Your Sears Kenmore Microwave Oven has added value when you consider that Sears has a service unit near you, staffed by Sears Trained Technicians-professional technicians specifically trained on Sears Kenmore Microwave Ovens, having the parts, tools and equipment to insure that we meet our pledge to you-"We Service What We Sell!"

TO FURTHER ADD TO THE VALUE OF YOUR MICROWAVE OVEN, BUY A SEARS MAINTENANCE AGREEMENT.

Sears Kenmore Microwave Ovens are designed, manufactured, and tested for years of dependable operation. Yet, any modern appliance may require service from time to time. A Sears Maintenance Agreement is more than an extension of the Warranty.

It provides complete protection from unexpected repair bills and undue inconvenience. It assures you of maximum efficiency from your Microwave Oven.

Here's a comparative warranty and Maintenance Agreement chart showing you the benefits of a Sears Microwave Oven Maintenance Agreement.

YEARS OF OWNERSHIP COVERAGE	1 st Yr.	2 nd Yr. thru 5 th Yr
1. Replacement of defective parts other than magnetron	W	MA
2. Replacement of magnetron	W	W
3 Annual preventive maintenance check at your request	MA	MA

W-WARRANTY

MA-MAINTENANCE AGREEMENT

Contact your Sears salesperson or local Sears Service Center today and purchase a Sears Maintenance Agreement.

WARRANTY

Kenmore® MICROWAVE OVEN

FULL ONE YEAR WARRANTY ON MICROWAVE OVEN

FOR ONE YEAR FROM THE DATE OF PURCHASE, IF THIS KENMORE MICROWAVE OVEN FAILS DUE TO A DEFECT IN MATERIAL OR WORKMANSHIP, SEARS WILL REPAIR IT, FREE OF CHARGE.

FULL FIVE YEAR WARRANTY OF THE MAGNETRON

FOR FIVE YEARS FROM THE DATE OF PURCHASE, IF THE MAGNETRON IN THIS KENMORE MICROWAVE OVEN FAILS DUE TO A DEFECT IN MATERIAL OR WORKMANSHIP, SEARS WILL REPAIR IT, FREE OF CHARGE.

THE ABOVE WARRANTY COVERAGE APPLIES ONLY TO MICROWAVE OVENS WHICH ARE USED FOR PRIVATE HOUSEHOLD PURPOSES.

WARRANTY SERVICE IS AVAILABLE BY SIMPLY RETURNING MICROWAVE TO SEARS SERVICE CENTER IN THE UNITED STATES.

THIS WARRANTY APPLIES ONLY WHILE THIS PRODUCT IS IN USE IN THE UNITED STATES.

THE WARRANTY GIVE YOU SPECIFIC LEGAL RIGHTS, AND YOU MAY ALSO HAVE OTHER RIGHTS WHICH VARY FROM STATE TO STATE.

SEARS, ROEBUCK AND CO., D/817 WA, HOFFMAN ESTATES, IL. 60179

EASY USE CHART

REHEAT BY QUICK TOUCH

1. Touch **BEVERAGE, PLATE OF FOOD or CASSEROLE**
1-3 times until desired serving number appears.
2. Touch **START**.

QUICK-ON COOKING

- (HI-power only)
1. Touch **QUICK ON**.
 2. Touch number (1-9) for cooking time (minutes).

TIME COOKING

1. Touch **TIME**.
2. Touch numbers for cooking time.
3. Touch **POWER LEVEL**.
4. Touch number (1-9) for power level.
5. Touch **START**.

NOTE: To set HI-Power cooking, skip steps 3 and 4.

FROZEN FOOD COOKING BY QUICK TOUCH

[89380/89381 only]

1. Touch **FROZEN DINNER, FROZEN ENTREE or FROZEN VEGETABLES**
1-3 times until desired weight appears.
2. Touch **START**.

POPCORN POPPING

1. Touch **POPCORN**.
(3.5 oz bag size only)
2. Touch **START**.

AUTOMATIC DEFROST

1. Touch **AUTO DEFROST**.
2. Enter the weight of food in lb.
3. Touch **START**.
4. At pause, rearrange food.
5. Touch **START** to restart.

HOLD WARM

1. Touch **HOLD WARM**.
2. Set desired cooking program.
3. Touch **START**.

MINUTE TIMER

1. Touch **TIME**.
2. Touch numbers for time.
3. Touch **POWER LEVEL**.
4. Touch **0** (power level 0).
5. Touch **START**.

CLOCK

1. Touch **TIME OF DAY**.
2. Touch numbers for time of day.
3. Touch **TIME OF DAY**.

SEARS

For your protection in the event of theft or loss of this product, please fill in the information below :

Model No.

(Located on the back of the unit)

Serial No.

(Located on the back of the unit)

Date of Purchase

Purchased Price

Where Purchased

Sears Roebuck and Co., Hoffman Estates, IL. 60179, U.S.A.