

Amana®

Top Freezer Refrigerator Use & Care Guide

CONSUMER INFORMATION LINE



TOLL FREE

1-800-843-0304

Amana
A **Raytheon** Company

Contents

Installation		Other Features	
Electrical Requirements	2	Decorator Doors	10
Model Identification	3	Normal Operating Sounds	11
Setting Controls	4	Care and Cleaning	
Refrigerator Features	5	Exterior	12
Installing and Using Specific Features	6	Adhesives	12
Adjustable Cantilever Shelves	6	Interior	12
Deli Fresh Chiller	6	Dairy Storage Door	12
Utility Rack	7	Second Serving Containers	12
Crispers	7	Shelf Removal	12
Egg Storage	7	Door Shelves	12
Adjustable Door Buckets	7	Crisper Drawer and Shelf Removal	13
Door Shelves	8	Odor Removal	14
Tall Package Retainer	8	Door Gaskets	14
Huggers	8	Mechanical	14
Dairy Storage	8	Condenser Coil	14
Food Storage Containers	9	Light Bulbs	14
Butter Dish	9	Energy Tips	15
Freezer Features		Vacation Tips	15
Free-O'-Frost™	9	Before Calling For Service	16
Ice Cube Trays	9	Amana Warranty	18
Ice Service Rack	9	Warranty Exclusions	
Automatic Ice maker	10	Temperatures	18
Freezer Door Shelves	10	Removing/Reversing Doors	18
Reversible Freezer Storage Rack	10	Amana Asure™ Extended Service Plan	20
Adjustable Cantilever Shelves	10	Amana Consumer Information Line	20

Electrical Requirements

RECOGNIZE THIS SYMBOL AS A SAFETY PRECAUTION

WARNING

Electrical Grounding Instructions—This appliance is equipped with a three-prong (grounding) plug for your protection against possible shock hazards. Where a two-prong wall receptacle is encountered, it is the personal responsibility and obligation of the customer to contact a qualified electrician and have it replaced with a properly grounded three-prong wall receptacle in accordance with the National Electrical Code.

Unit is designed to operate on a separate 103 to 126 volt, 15 amp., 60 cycle line.

DO NOT UNDER ANY CIRCUMSTANCES CUT OR REMOVE THE ROUND GROUNDING PRONG FROM THE PLUG. THE UNIT MUST BE GROUNDING AT ALL TIMES. DO NOT REMOVE WARNING TAG FROM THE SERVICE CORD.

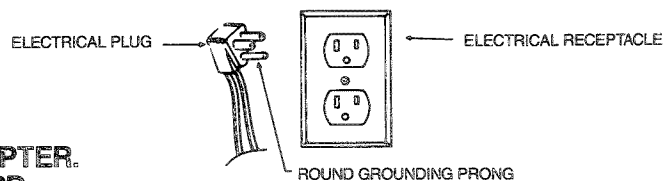

 **WARNING**
DO NOT USE A TWO-PRONG ADAPTER.
DO NOT USE AN EXTENSION CORD.

Amana Top Freezer Refrigerator

Thank you for buying an Amana refrigerator. Your satisfaction with this new product is very important to us. This Use and Care Guide will help you understand how your refrigerator operates...and how to get the most benefit from the features you selected.

Please read this Use and Care Guide thoroughly.

Complete the Registration Card in the packet with this guide and return to Amana's Product Registration Department promptly. If your registration card is missing, call 1-800-843-0304.

If you believe something is operating incorrectly, please read the "Before You Call for Service Section," on pages 16-17. If you still have questions, please call us at 1-800-843-0304. (Weekdays, during normal business hours.)

Any time you call or write us regarding your refrigerator, have the following information readily available. It is located on a nameplate, found in the upper left-hand front corner of the refrigerator section. Take a moment to fill in the information so you have it handy!

Serial No. _____
Model No. _____
Manufacturing No. _____

Please also record:

Date of purchase: _____
Selling dealer: _____
Dealer address: _____

Keep a copy of your sales receipt for future reference, in case warranty service is required.

Did you know Amana offers a complete line of kitchen and laundry appliances...freezers, ranges, cooktops, wall ovens, microwave ovens, dishwashers, washers, and dryers? We also manufacture a complete selection of high efficiency gas furnaces plus both central and room air conditioners. We hope you'll consider Amana the next time you need one of these products.

Enjoy your new refrigerator.

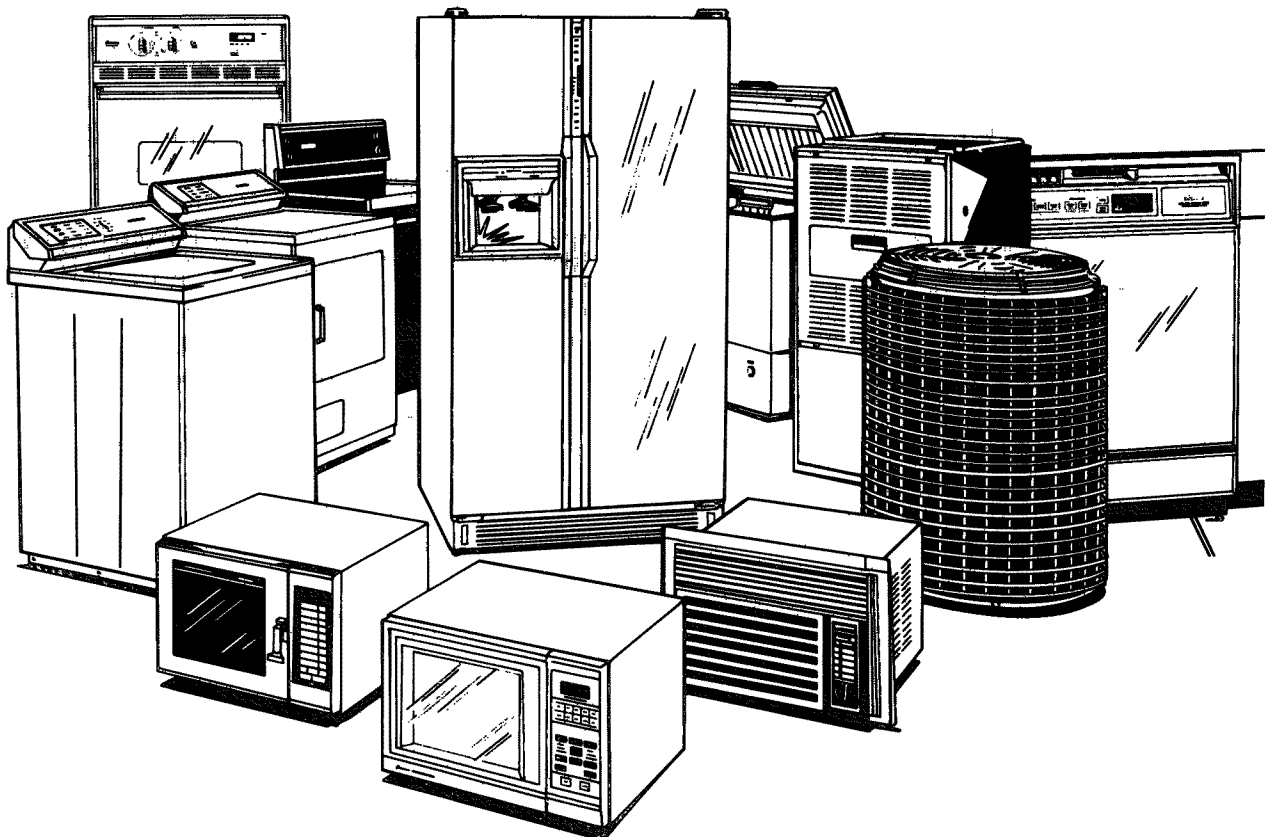

Setting The Controls

Temp-Assure™ thermostatic control

This control, located on center divider between freezer and refrigerator sections, operates independently of freezer control. A hidden thermostatic sensor measures refrigerator air temperature constantly, and automatically lets in more cold air if temperature rises as little as $1\frac{1}{2}^{\circ}\text{F}$ ($.8^{\circ}\text{C}$) from setting.

Refrigerator and freezer controls

- a. Locate refrigerator and freezer controls at center divider between freezer and refrigerator sections. See Figure 1.



Figure 1

- b. When freezer control is set to "OFF", neither refrigerator or freezer sections will cool.
- c. Start by setting both controls to "4". After 24 hours, adjust as desired. "1" is warmest setting. "7" is coldest.
- d. If you want to set temperatures more precisely, use a household thermometer that includes temperatures between -5° to $+50^{\circ}\text{F}$ (-20.5° to $+10^{\circ}\text{C}$). These can normally be purchased at a hardware store.
- e. In freezer section, put thermometer snugly between frozen food packages. See Figure 2.

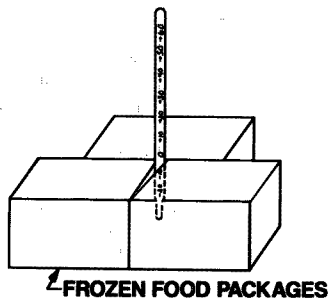

Figure 2

- f. Wait 5-8 hours. If temperature is not 0° to 2°F . (-18° to -17°C), adjust control, one number at a time. Check again after 5-8 hours.
- g. In refrigerator section, place thermometer in a glass of water and place in middle of refrigerator. Wait 5-8 hours. If temperature is not 38° to 40°F ($+3^{\circ}$ to $+4^{\circ}\text{C}$), adjust the control, one number at a time. Check again after 5-8 hours. See Figure 3.

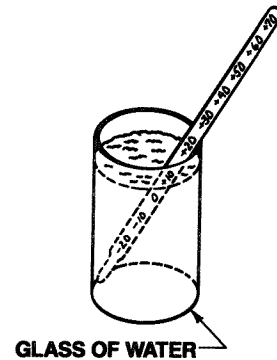

Figure 3

Exterior Cabinet Moisture Control

During hot, humid weather, any refrigerator will form moisture around doors, similar to condensation that forms on a glass of ice water. Special heaters in the refrigerator cabinet help minimize condensation.

- a. If refrigerator is in a warm, humid area, set control to "ON" position.
- b. If refrigerator is in a cooler, less humid area, set control to "OFF" position.
- c. As weather conditions change, this setting may need to be adjusted. At any time moisture forms on refrigerator cabinet, move control to the "ON" position. See Figures 4 & 5.

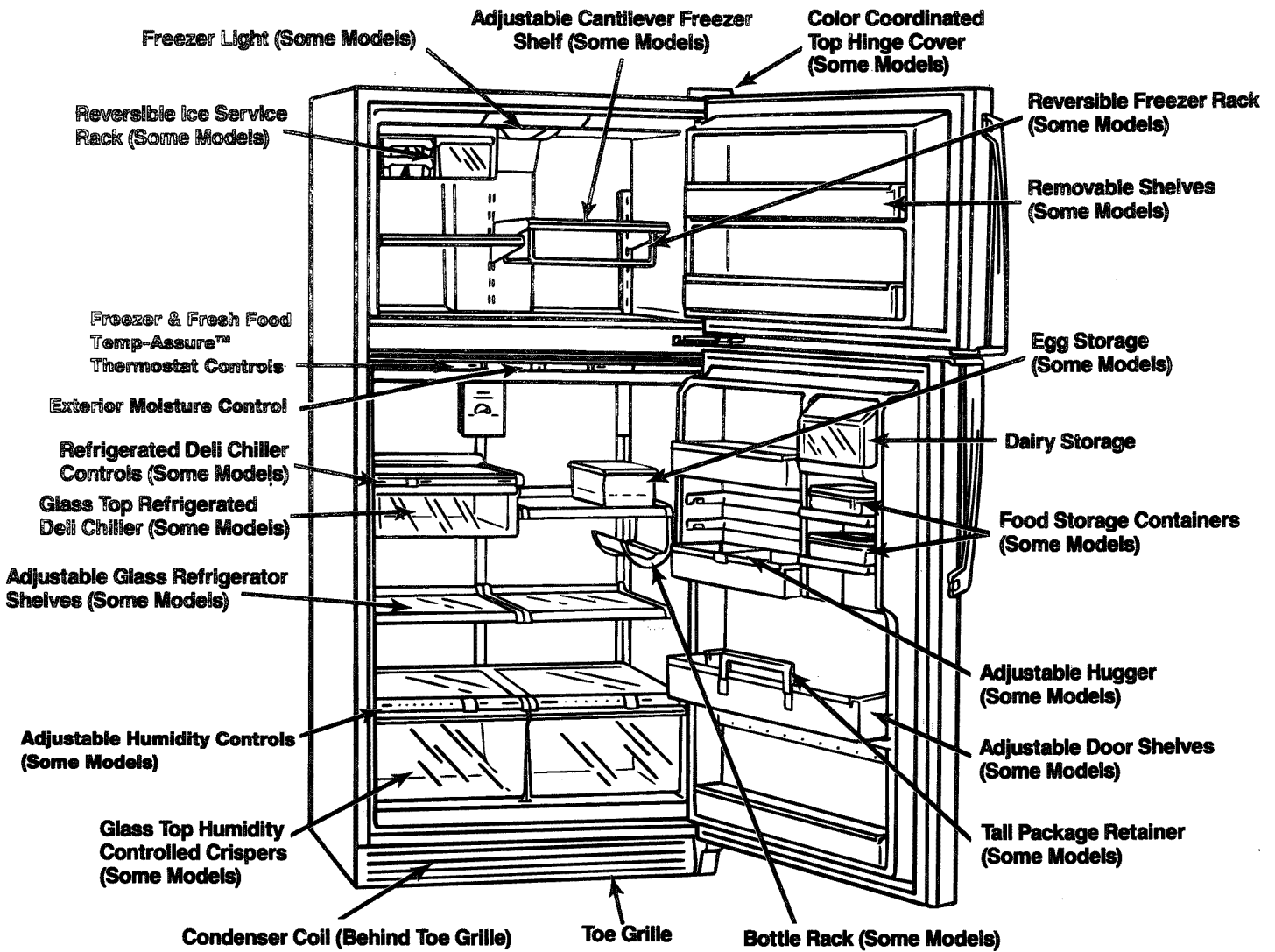

Figure 4



Figure 5

Refrigerator Features



IMPORTANT NOTE:

*FEATURES MAY VARY FROM MODEL TO MODEL. YOUR REFRIGERATOR MAY NOT HAVE ALL OF THE FEATURES SHOWN.

Figure 6



Installing and Using Specific Features

Refrigerator

Adjustable cantilever shelves (some models)

Shelves can be adjusted to best match size of items stored in refrigerator. These shelves are supported by metal tracks in back of the refrigerator.

- To remove "cantilever" shelves, tap upward at back of shelf, near the metal track. See Figure 7. This will loosen shelf hooks. Lift shelf and pull out.

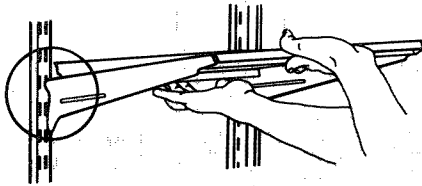

Figure 7

- To install, tilt shelf so that front is higher than back.
- Insert metal hooks at back of shelf into desired slot in metal track on back wall of refrigerator. See Figure 8.

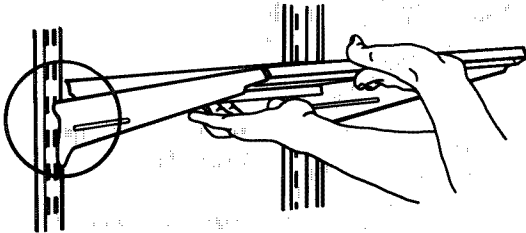

Figure 8

CAUTION:
Apply pressure to front edge of shelf to insure proper installation.

Deli Fresh Chiller (some models)

The Deli Fresh Chiller features a drawer inside an outer sleeve. A control, located on front trim, allows you to adjust amount of freezer air circulating between Deli Fresh Chiller and sleeve to keep meat, fish or poultry fresh without drying it out.

- Slide control to left for coldest temperatures (ice crystals may form) and to right for warmer temperatures. See Figure 9.



Figure 9

- Additional cold air can affect refrigerator compartment so Temp-Assure™ control may need to be adjusted once the Deli Fresh Chiller control is set. See page 4.

To move Deli Fresh Chiller to new location (some models)

- Remove Deli Fresh Chiller drawer.
- Tap upward on back of shelf, near metal track. This will loosen shelf hooks.
- Lift shelf and Deli Fresh Chiller sleeve and pull out.
- To reinsert, lift the shelf and sleeve so front is higher than back.
- Insert metal hooks at back of shelf into desired slot in metal track on back wall of refrigerator. (Any of top three slots will work.)
- Gently lower shelf front. Tap downward near track until shelf hooks are securely seated and shelf is level.
- Reinsert Deli Fresh Chiller drawer.

If you choose to move Deli Fresh Chiller to opposite side of refrigerator, be sure to move reversible Deli Fresh Chiller control (located on center back wall of refrigerator section) to match the same side as you place the Deli Fresh Chiller. See Figure 10.

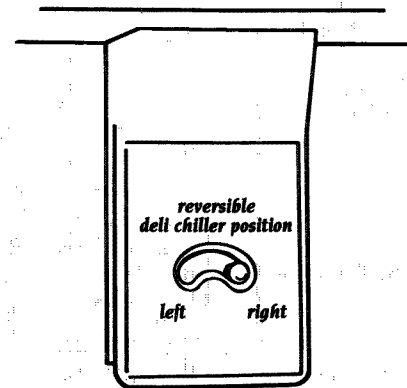

Figure 10

Crisper drawers

Crisper drawers are used to store fresh fruits and vegetables. It is normal for some moisture to accumulate inside drawers. Some models have humidity controls on one or both drawers.

- Slide control to high humidity setting for leafy vegetables such as lettuce, spinach or cabbage. See Figure 14.



Figure 14

- Slide control to low humidity setting for produce with skins, such as apples, oranges or tomatoes. See Figure 14.

Installing and Using Specific Features (Cont.)

Utility rack (some models)

This rack can be hung from edge of any shelf, to hold a large bottle, eggs, cheese, etc., within easy reach.

- Locate utility rack shipped inside crisper drawer.
- Locate tabs on flat edge of utility rack. Hook these tabs over metal frame on side of any shelf. Shelf may need to be moved, depending on location.
- If bottle is used, be sure bottle cap is on tightly before placing bottle in rack. See Figures 11, 12 and 13.

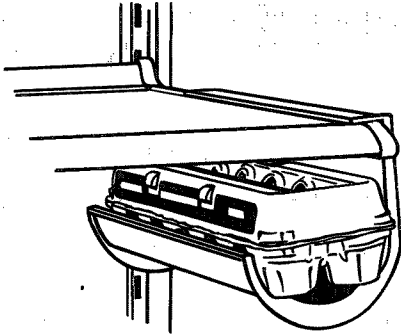

Figure 11

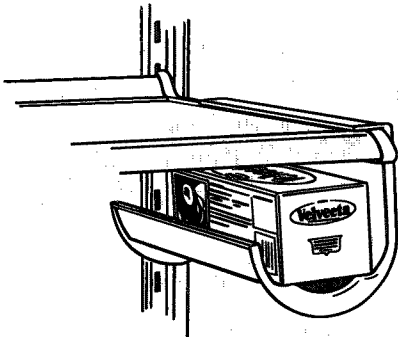

Figure 12

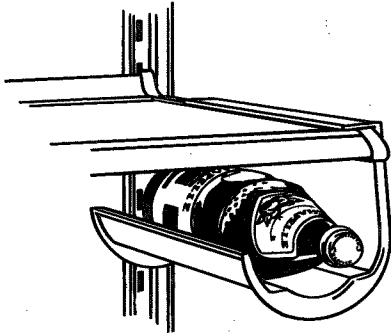

Figure 13

Egg storage

- Some models have a take-to-the-counter egg bucket with a removable tray. See Figure 15.

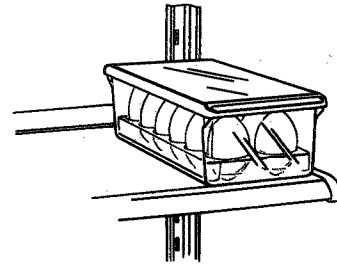

Figure 15

Adjustable door buckets (some models)

Some models feature door buckets that can be moved up or down to fit storage needs.

- To remove door buckets, remove food from all buckets.
- Push lock tabs toward center with your thumbs and forefingers. See Figure 16.

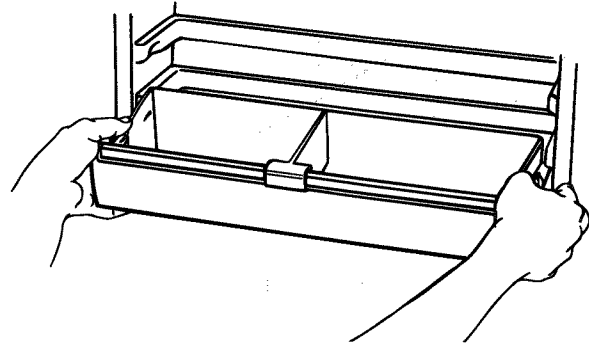

Figure 16

- Pull bucket straight out. See Figure 17.

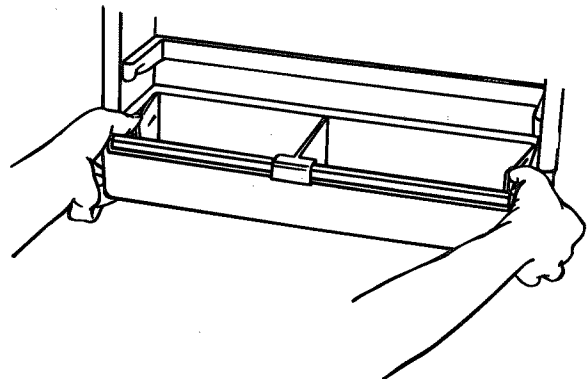

Figure 17

Installing and Using Specific Features (Cont.)

- d. To install, slide bucket into grooved area until tabs lock into place. See Figure 18.

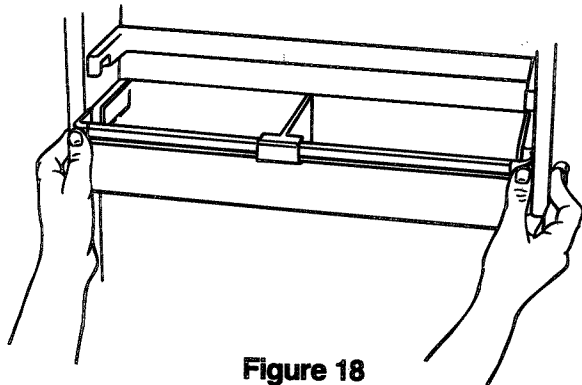

Figure 18

Door Shelves

There are two door shelves on refrigerator door that allow for easy access of food.

- To remove door shelves, remove food from all shelves.
- Grasp each side of retainer.
- Pull shelf straight up. See Figure 19.

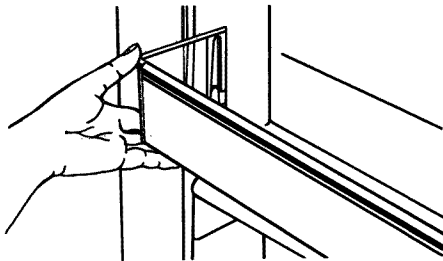

Figure 19

- d. Then pull out to remove. See Figure 20.

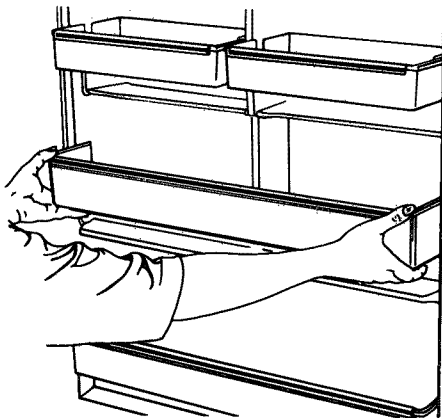

Figure 20

Tall package retainer

Allows you to place tall packages or containers in door buckets or door shelves. Retainer keeps packages securely in place.

- To remove, rotate retainer away from you, and lift up. See Figure 21.

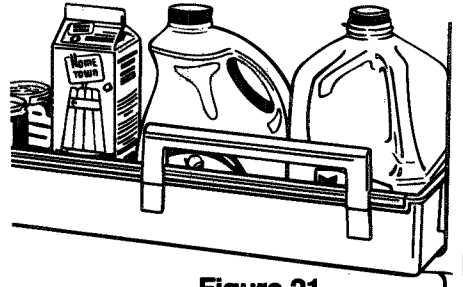

Figure 21

Door shelf "huggers" (some models)

Huggers are dividers which fit into door shelf to keep bottles, etc. in place.

- Hook hugger over edge of door shelf. See Figure 22.



Figure 22

- Slide side to side as needed.

Dairy storage

Store butter and cheese in this compartment. See Figure 23.

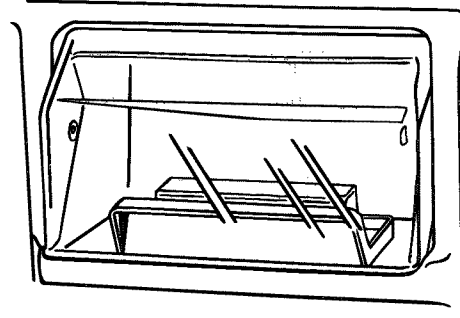

Figure 23

- Tilt door up for easy access.
- Butter dish can be taken to table and is dishwasher and microwave safe. Place dish in top rack of dishwasher.

Installing and Using Specific Features (Cont.)

Food storage containers (some models)

Some models feature two sealable leftover containers.

- They store conveniently in this compartment and slide out for easy access. See Figure 24.
- Containers are microwave and dishwasher safe. Place in top rack of dishwasher.
- If containers stain, follow manufacturer's instructions for cleaning.
- Follow manufacturer's instructions when using containers to reheat foods in a microwave oven.

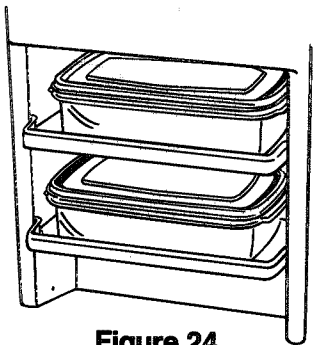

Figure 24

Butter Dish

Allows you the convenience of tablespoon portions. See Figure 25.

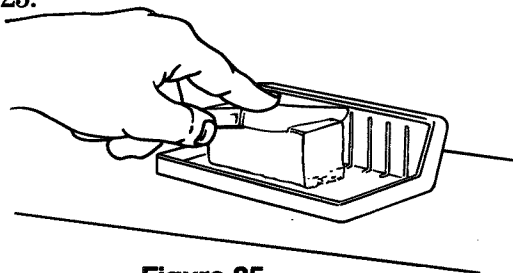

Figure 25

Freezer

Free-O'-Frost™ system

Freezer and refrigerator sections are completely frost free. The Amana Frost-Magnet® evaporator coil in back wall stops frost before it starts. Under normal operating conditions, you'll never have to defrost refrigerator or freezer, because it's automatic.

Ice cube trays (some models)

- To release ice cubes, grasp both ends of tray.
- Twist in opposite directions until ice pops out. See Figure 26.

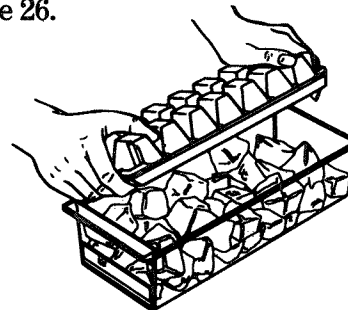

Figure 26

- Some models have a portable ice bucket to store ice.

Ice service rack (some models)

Some models have an ice service rack. Rack has a drawer to store ice.

- To move ice service rack to right of freezer, first remove ice trays and drawer.
- Slide rack about $\frac{3}{8}$ " (9.5 mm) toward front of freezer, until screws are in middle mounting holes.
- Gently pull rack away from ceiling of freezer to remove from screws.
- Remove screws from ceiling of freezer.
- Using a flat screwdriver covered with tape (to keep from scratching ceiling), gently pry plastic plugs from opposite side of ceiling of freezer.
- Replace plastic plugs with screws and vice versa.
- Line up middle mounting holes in top of ice service rack with screws on ceiling of freezer. Gently slide ice service rack back about $\frac{3}{8}$ " (9.5 mm).
- Replace ice cube trays and drawer.

Automatic icemaker (some models)

Some models have an automatic icemaker already installed. Other models have a connection in the freezer back wall for installation of an optional icemaker, available at extra cost from your Amana dealer.

- Top left cantilever shelf must be in the slot with label marked bottom when using an automatic icemaker. Refer to label on interior of freezer.
- Models with full width shelf place shelf in the bottom position.
- Put the ice bin under the icemaker.
- Lower wire "arm" to start ice production.
- First batch of ice will normally be produced within 12 hours of installation.
- Discard first several batches of ice so that any impurities in water line of icemaker will not be consumed.
- To stop ice production, raise "arm" of icemaker until it locks in position.

Installing and Using Specific Features (Cont.)

Freezer door shelves

There are two full-width door shelves located on freezer door for convenient storage.

- a. Shelves can be removed for easy cleaning. To remove, follow directions in step A-C on page 8.

Reversible freezer storage rack (some models)

Reversible freezer storage rack may be placed on top of or underneath freezer shelf to be used to organize and separate frozen foods. See Figure 27.

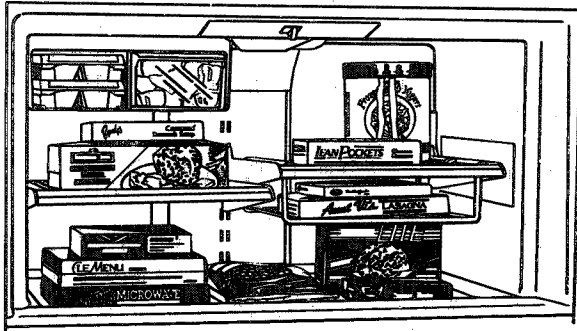

Figure 27

- a. To remove storage rack, first remove food from rack.
- b. Hold each end of rack and push rack to right to release rack slot from wire shelf.
- c. Pull down if located under freezer shelf. Lift up if located above freezer shelf.
- d. To replace storage rack, position rack on top of or underneath freezer shelf between shelf wires.
- e. Center slot of rack should be positioned on top of or underneath center wire of freezer shelf.
- f. Lock into place by pushing rack to left. Be sure round knobs are securely in place. See Figure 28.

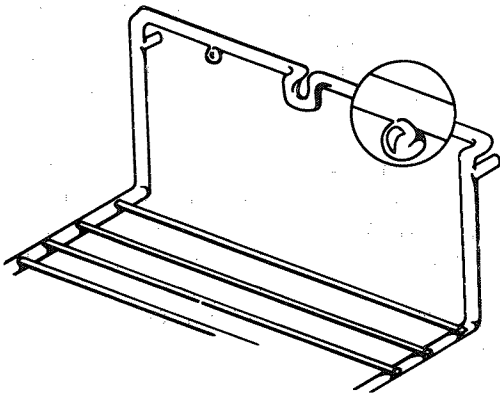

Figure 28

Adjustable freezer cantilever shelves (some models)

Shelves can be adjusted to best match size of items stored in freezer. These shelves are supported by metal tracks in back of the refrigerator.

- a. To remove "cantilever" shelves, tap upward at back of shelf, near the metal track. See Figure 29. This will loosen shelf hooks. Lift shelf and pull out.

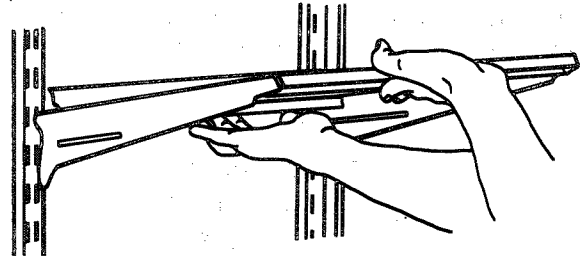

Figure 29

- b. To install, tilt shelf so that front is higher than back.
- c. Insert metal hooks at back of shelf into desired slot in metal track on back wall of freezer. See Figure 30.

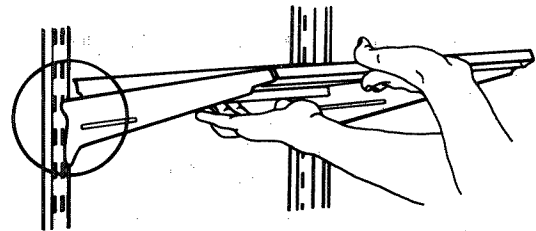

Figure 30

CAUTION:

Apply pressure to front edge of shelf to insure proper installation.

Other Features

Decorator doors

Door fronts of most refrigerators can be decorated with panels to accent your kitchen decor. Trim kits can be purchased separately from your Amana dealer.

- a. Basic $\frac{1}{16}$ " (1.6 mm) trim kit attaches to door edges and can accommodate $\frac{1}{16}$ " (1.6 mm) thick panels.
- b. For panels that are $\frac{1}{4}$ " (6.4 mm) thick, an additional trim kit is required. $\frac{1}{4}$ " (6.4 mm) kit attaches to panels and slides tongue-in-groove fashion into $\frac{1}{16}$ " (1.6 mm) trim, which must be installed on doors first.
- c. Ask your Amana dealer about panel availability on special models or you may supply your own panels.
- d. Amana does not supply custom panels.

Normal Operating Sounds Of Today's Refrigerators

Your new refrigerator may be replacing a differently designed, smaller refrigerator or a product which operated less efficiently. Today's refrigerators have new features such as automatic icemakers and automatic defrost. They also are designed to be more

energy efficient and operate as economically as possible. With this new design, you may hear sounds which are unfamiliar to you, yet they are quite normal and do NOT require a service call.

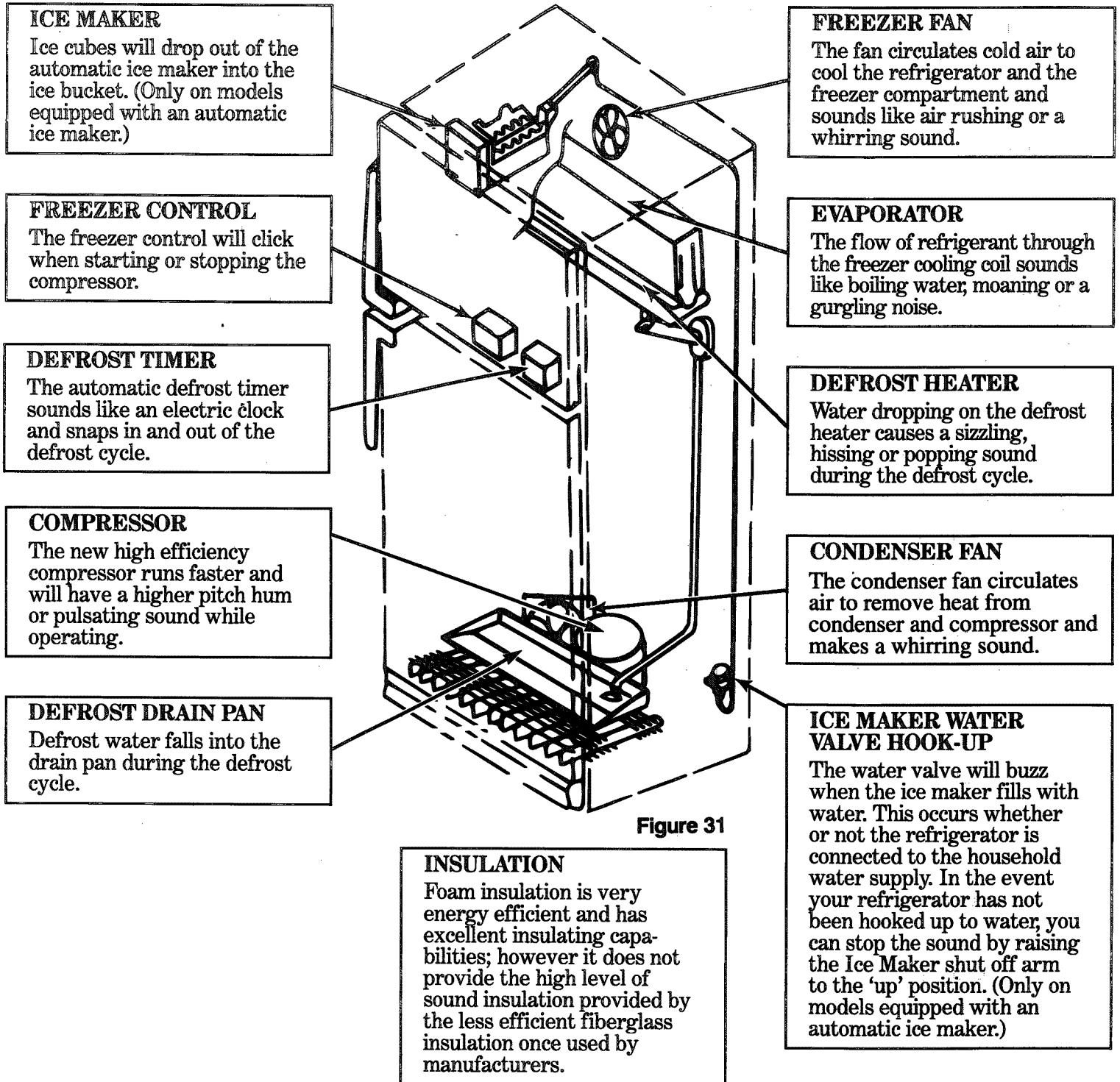

Figure 31

All of these sounds are normal and will soon become familiar. They indicate the unit is operating and performing as designed.

Care and Cleaning Of Your Refrigerator

Exterior

- Wash refrigerator cabinet with warm, soapy water as needed.
- Do not use:
 - Concentrated liquid dishwashing detergent (Dilute with warm water before using.)
 - Abrasive cleaners such as COMET, AJAX, etc.
 - Solvents
 - Metal scouring padsThese can cause surfaces to scratch, crack and discolor.

Adhesives

- To remove glue from stickers, labels and strapping tape, dab non-abrasive toothpaste over adhesive.
- Rub adhesive with fingers and rinse.

Interior

CAUTION:
TO AVOID ELECTRICAL SHOCK: Unplug power cord or open household circuit breaker to refrigerator before replacing a burned out light bulb or before cleaning. After cleaning or changing light bulb, reconnect power.

- Wash with warm, soapy water.
- Rinse and dry.
- Do not use abrasive heavy-duty powders such as AJAX or COMET.
- Avoid metal or abrasive cleaning pads.
- Do not use concentrated liquid detergent. These cleaners may cause scratching, cracking or discoloration.
- Butter dish, and "second serving" leftover containers can be washed in top rack of an automatic dishwasher. Other parts should be hand washed.

Dairy storage door

- Lift door up.
- Place forefingers on either side of door near the hinge where the dairy door and refrigerator liner connect.
- Flex in slightly.
- Pull out.

Second serving containers (some models)

- Containers are microwave safe.
- Follow manufacturer's instructions when using containers to REHEAT food in a microwave oven.
- Containers are dishwasher safe. Always place in top rack of dishwasher.
- If containers should stain, follow manufacturer's instructions for cleaning.

Shelf removal

- Remove second servers from shelf. Remove floor of shelf by lifting up from bottom of top shelf, lift floor up and out. See Figure 32.

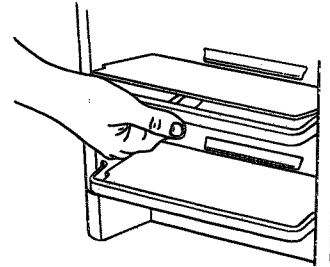

Figure 32

- Press ends of retainer bar towards center and pull retainer bar straight out. See Figure 33.

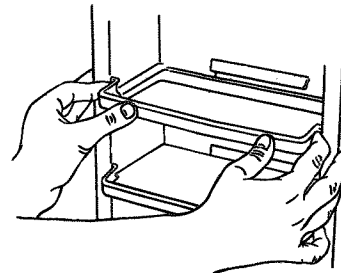

Figure 33

Door shelves

There are two door shelves on refrigerator door that remove for easy cleaning.

- Grasp each side of retainer.
- Pull shelf straight up. See Figure 34.

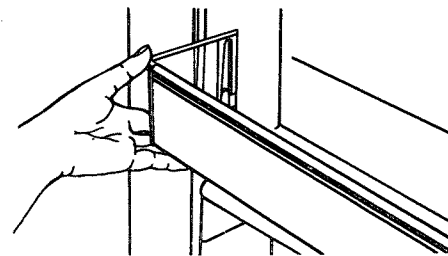

Figure 34

- Then pull out to remove. See Figure 35.

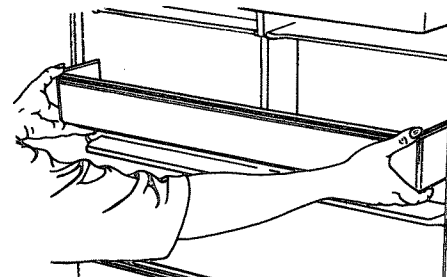

Figure 35

Care and Cleaning Of Your Refrigerator (Cont.)

Crisper drawer and shelf removal

Crisper drawers can be removed, even when door is opened at a 90° angle, for easy cleaning.

- a. Remove food from crisper drawer.
- b. Remove food from shelves located above crisper drawer and below meat keeper.
- c. **NOTE:** It may be necessary to remove cantilever shelves located above crisper drawers in order to remove bottom glass shelf.
- d. Open drawer of left* hand crisper.

CAUTION:
Handle Tempered Glass shelves with care. Chipping and scratching may cause them to break suddenly. Do not expose shelves to rapid temperature changes. Replace immediately if scratched or chipped.

- e. Place one hand underneath glass shelf and push up.
- *For refrigerators hinged on left use crisper on right.
- f. Grasp shelf with other hand and tilt glass upward at one end and remove from refrigerator. See Figure 36.

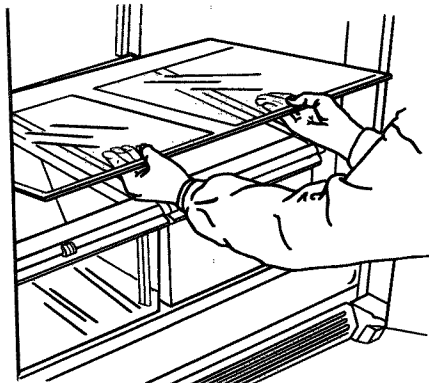

Figure 36

- g. Place shelf on a soft surface. Wash shelf with warm soapy water. Rinse and dry thoroughly.
- h. Reverse procedure to replace bottom glass shelf.
- i. Remove crisper system on left* side by grasping and lifting up top front with one hand while reaching underneath drawer and pushing up with other hand. See Figure 37.

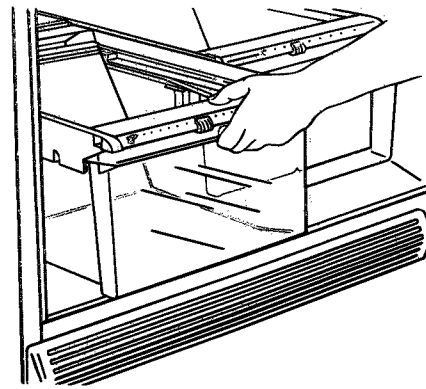

Figure 37

- *For refrigerators hinged on left use crisper on right.
- j. Remove crisper from support which fits into recess at bottom center of refrigerator. See Figure 38.

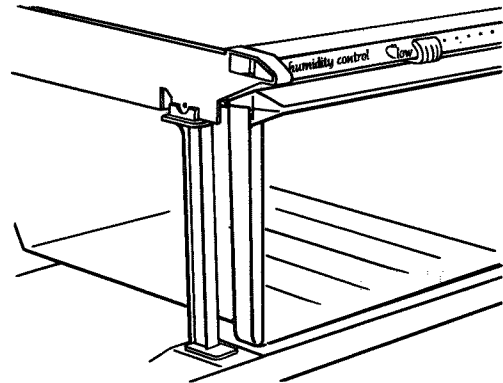

Figure 38

- k. Slide other crisper system to left* and slide out. See Figure 39.

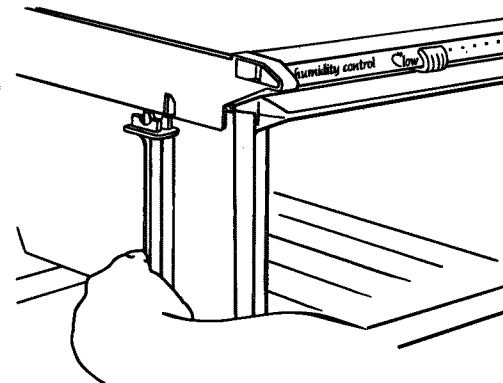

Figure 39

- *For refrigerators hinged on left use crisper on right.
- l. Reverse procedure to replace crisper drawers.

Care and Cleaning Of Your Refrigerator (Cont.)

Odor removal

- a. Disconnect electrical power plug.
- b. Remove all food.
- c. Thoroughly wash inside of unit, including all shelves, drawers, accessories and gaskets, with a mixture of 4 tablespoons of baking soda dissolved in a quart of warm water. Pay special attention to any corners, crevices or grooves into which odor-causing liquids may have seeped.
- d. Dry thoroughly.
- e. Return food to refrigerator; washing off all bottles, jars and containers before placing them into refrigerator and freezer.
- f. Plug in refrigerator. Wait 24 hours before checking to see if odor has been eliminated. If odor is still present, please call the Amana Consumer Information Line toll free (1-800-843-0304) for additional cleaning methods.

Door gaskets

- a. Clean refrigerator and freezer gaskets at least twice a year with a mild detergent diluted in water.
- b. **Do not** clean with cleaners which contain ammonia or chlorine bleach.
- c. Rinse and dry.
- d. Apply a light film of petroleum jelly to gaskets to help keep them soft and pliable.

Mechanical

Condenser coil

It is important to clean condenser coil of any refrigerator every three months. Dust and lint will:

- reduce cooling performance.
 - cause refrigerator to waste energy.
 - shorten life of the compressor and other components.
- a. Grasp toe grille at each end. Pull forward to remove. See page 5 for location of coil.
 - b. Use a long handled bottle brush and a vacuum cleaner hose nozzle to remove dust and lint from condenser coil at bottom of refrigerator. A special brush can be purchased from your Amana dealer — part no. R1930-4.
 - c. Snap toe grille into place.
 - d. Additional cleaning may be done if refrigerator is pulled away from wall. Run a vacuum brush across condenser fan outlet grille on lower back of refrigerator.

Light bulb

You will need a 40 watt appliance bulb such as:
Amana #A0282803
GE or Westinghouse #40A15/1
Sylvania #40A15

These can usually be purchased from your appliance dealer or a hardware store.

CAUTION:
TO AVOID ELECTRICAL SHOCK: Unplug power cord or open household circuit breaker to refrigerator before replacing a burned out light bulb or before cleaning. After cleaning or changing light bulb, reconnect power.

- a. Disconnect power to unit.
- b. Allow bulb to cool if hot.
- c. Wear gloves to protect your hand should the bulb break.
- d. Unscrew screw at back center of light cover and pull light cover straight down. (There are small supports one each side to hold cover in place that need to release.) See Figure 40.

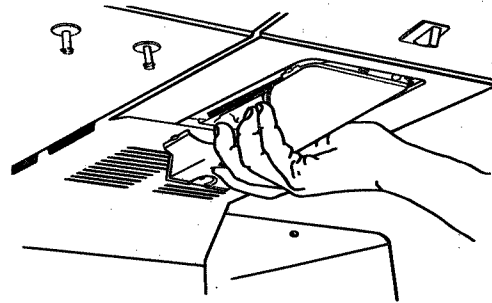

Figure 40

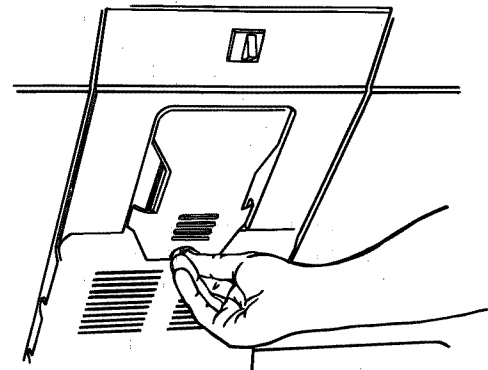

Figure 41

- e. Unscrew light bulb by rotating bulb counterclockwise.
- f. Screw the new bulb in place, rotating bulb clockwise.
- g. Snap light cover back in place and return screw back to center back of light cover. See Figure 41.
- h. Plug in refrigerator.

Energy Tips

Your Amana refrigerator is designed to be one of the most energy efficient refrigerators available. You can help reduce energy use by following these suggestions:

- a. Set freezer, refrigerator and meat keeper controls so compartments are no colder than necessary. See page 4 for details.
- b. Your refrigerator will use less energy if freezer section is kept full. A full freezer helps maintain frozen temperatures when door is opened.
- c. Keep door gaskets clean and lightly lubricated with petroleum jelly. Replace worn door gaskets. If door gaskets become dirty and worn,
 - d. Block heat and sunlight. Install your refrigerator away from heat sources and direct sunlight.
 - e. Clean condenser coil. A dirty condenser will cause refrigerator to use more energy. See instructions on page 14 for cleaning instructions.
 - f. Use the Cabinet Moisture Control when humidity is high. This control regulates a heater which reduces condensation during periods of high humidity. In periods of low humidity this control can be set to "Off" position. See page 4.

Vacation Tips

- a. Remove perishable foods from refrigerator.
- b. If you have an icemaker, shut it off. Move wire "arm" to upper position. Turn water supply to refrigerator off at saddle valve (valve controlling water supply to refrigerator).
 - c. If leaving for an extended period —
 - empty refrigerator
 - unplug it
 - clean it
 - prop door open, so air can circulate inside

Before Calling For Service:

You may save time and expense of a service call by checking for these common problems before you call for service.

<p>Refrigerator does not operate</p>	<ul style="list-style-type: none"> • Does the light work? A dim light indicates low voltage or a weak bulb. • Is the electrical power cord plugged in? • Is a fuse or circuit breaker open? Check by plugging in another appliance or lamp at the same wall outlet. • If the lights work and the freezer control is on, but the two fans and compressor are not operating, the refrigerator is most likely in the defrost cycle. Wait 40 minutes to see if the refrigerator will restart.
<p>If the refrigerator still won't operate</p>	<ul style="list-style-type: none"> • Unplug the refrigerator and take the steps necessary to preserve the food stored in the refrigerator. Dry ice may be placed in the freezer section of the refrigerator to preserve food until the refrigerator can be serviced. Doors should be left closed until the refrigerator has been repaired. Your product warranty does not cover food loss. • If you have questions regarding the steps above, call Amana's Consumer Information Line Toll Free 1-800-843-0304. • Call your nearest Amana dealer or authorized service center listed in the Yellow Pages.
<p>If food temperature appears too warm</p>	<ul style="list-style-type: none"> • See section 1 above. • Have you recently added a large supply of food? Allow adequate time for the food to reach refrigerated freezing temperature. • Is the condenser coil area clean? (See page 14) • Adjust refrigerator and/or freezer control. (See page 4)
<p>If the refrigerator has an odor</p>	<ul style="list-style-type: none"> • Clean the inside of your refrigerator/freezer. (See page 12)
<p>If the Deli Fresh Chiller is too warm</p>	<ul style="list-style-type: none"> • Is the Deli Fresh Chiller positioned in the proper place? (See page 6) • Slide Deli Fresh Chiller control to a colder setting. • Adjust freezer control to colder setting.
<p>If the refrigerator food temperature is too cold</p>	<ul style="list-style-type: none"> • Is condenser coil area clean? (See page 14) • Adjust refrigerator control. (See page 4) • Adjust freezer control to warmer setting. Allow several hours for temperature to adjust.
<p>If the refrigerator runs too much or too frequently</p>	<ul style="list-style-type: none"> • It may be normal to maintain an even temperature. • Is condenser area clean? (See page 14) • Have doors been opened frequently or for an extended period of time? • Is freezer running too cold? Adjust freezer control. (See page 4) • Check door alignment and gasket seal for proper closure.
<p>If the refrigerator makes unfamiliar sounds or seems too noisy</p>	<ul style="list-style-type: none"> • These may be normal operating sounds. Refer to page 11 for information on sounds the unit may make.

If water droplets (condensate) form on the inside of the refrigerator	<ul style="list-style-type: none"> • This is normal during periods of high humidity or during heavy usage.
If water droplets (condensate) form on the outside of the refrigerator	<ul style="list-style-type: none"> • Is Exterior Cabinet Moisture Control “ON”? This will help reduce condensate. • Check door alignment and gasket seal for proper closure.
If the crisper or Deli Fresh Chiller drawers do not close freely	<ul style="list-style-type: none"> • Check for a package which may be keeping it from closing properly. • Check to confirm drawer is in proper position in the assembly. • Clean drawer channels with warm, soapy water. • Apply a thin layer of petroleum jelly to slide channels. • Make sure refrigerator is level.
If there is an odor in the refrigerator or ice cubes	<ul style="list-style-type: none"> • Clean refrigerator and freezer. (See page 12) • Cover all foods tightly. • Use freezer containers or freezer wrap.
If ice cubes stick together or shrink	<ul style="list-style-type: none"> • Ice cubes may stick together or shrink if used infrequently. This is caused by air movement in the freezer, and does not indicate a malfunction. • Empty ice cube bucket or trays more frequently.
If ice forms in the fill tube to the icemaker	<ul style="list-style-type: none"> • This indicates sediment is in the valve, which kept the valve from closing. An in-line water filter should be added. If the problem persists, the valve will need to be cleaned or changed. • Low water pressure will cause valve to leak. Line piercing saddle valve should never be used as it can cause lower water pressure.
If the light bulb needs replacing	<ul style="list-style-type: none"> • See instructions for changing on page 14.

If you have any questions regarding the above, or need help in locating your nearest servicer, call Amana's Consumer Information Line Toll Free 1-800-843-0304.

Your Amana Refrigerator Warranty

Owner's Responsibility

- Secure proper installation of the refrigerator through an authorized Amana installer.
- Provide normal care and maintenance.
- Provide proof of purchase (sales receipt or canceled check) upon request.
- Replace light bulbs, shelves, drawers or other owner replaceable items, following instructions in use and care manual.
- Have appliance reasonably accessible for service.

What Is Covered

Full One-Year Warranty

For one year from date of original purchase we will provide, free of charge, parts and service labor in your home to repair or replace any part of the refrigerator that fails because of a defect.

Full Five-Year Warranty

For five years from date of original purchase, we will provide, free of charge, parts and service labor in your home to repair or replace any part of the sealed refrigerating system (the compressor, condenser, evaporator and all connecting tubing) that fails because of a defect.

We will also repair, free of charge, any defective food compartment liner. The door liner is covered only in the first year.

An automatic icemaker will be considered part of the refrigerator for warranty purposes when purchased with the refrigerator and installed at the factory or by the dealer.

This warranty is for products purchased for ordinary home use in the U.S. and Canada.

However, in Alaska, U.S. territories and Canada, the warranty in the second thru fifth years is LIMITED because you must pay to ship the product to the service shop or for the service technician's travel costs to your home.

All warranted service must be performed by an authorized Amana servicer. Service will be provided during normal business hours.

Look in the White or Yellow Pages of your telephone directory for authorized Amana servicers.

What Is Not Covered

- Service trips to your home to teach you how to use the product.

Read your Use and Care Guide. If you then have any questions about operating the product, please contact your dealer or our Consumer Affairs office at:

Amana Refrigeration, Inc.
Amana, Iowa 52204

or call, toll free:

1-800-843-0304

8:00 a.m.-4:30 p.m. CST

Weekdays

(Note: Toll free number is only available in the U.S.)

- Improper installation.

If you have an installation problem, contact your dealer or installer. Your dealer or installer is responsible for the correct installation of your refrigerator. You are responsible for providing adequate electrical, and plumbing hookups.

- Replacement of house fuses or resetting of circuit breakers.
- Failure of the product if it is used for other than its intended purpose or if used for other than normal home use.
- Damage to product caused by accident, fire, floods or acts of God.

AMANA REFRIGERATION, INC. IS NOT RESPONSIBLE FOR INCIDENTAL OR CONSEQUENTIAL DAMAGES*.

*Some states do not allow the exclusion or limitation of incidental or consequential damages, so the above limitation or exclusion may not apply to you. This warranty gives you specific legal rights, and you may also have other rights which vary from state to state. To know what your legal rights are in your state, consult your local or state consumer affairs office or your state's Attorney General.

Warranty Exclusions

Temperatures

This refrigerator/freezer is designed to operate in room temperatures no lower than 55°F (13°C). In lower room temperatures the compressor will not run enough to maintain proper refrigerator temperatures. Do not install in an area where room temperatures drop below 55°F (13°C).

Amana Refrigeration, Inc. will not pay warranty claims caused by improper installation.

Removing and Reversing Doors

Contact an authorized professional installer, trained by Amana to:

- Remove refrigerator and freezer doors.
- Reverse doors to change door swing.
- Install ice maker.



Rest assured against unexpected repair bills!

EXTENDED SERVICE PLAN

Amana is pleased to offer longer-term service protection on your new Amana refrigerator. The Amana Asure Extended Service Plan is specially designed to supplement the strong warranty described above. It combines with this standard warranty to provide budget-protecting coverage on your refrigerator for up to five full years, covering parts, labor and travel charges.

Your participating Amana dealer has details. Or contact us:

**Amana Refrigeration, Inc.
Customer Service Department
Amana, IA 52204**

CONSUMER INFORMATION LINE



**TOLL FREE
1-800-843-0304**