

ASSEMBLY & OPERATING INSTRUCTIONS

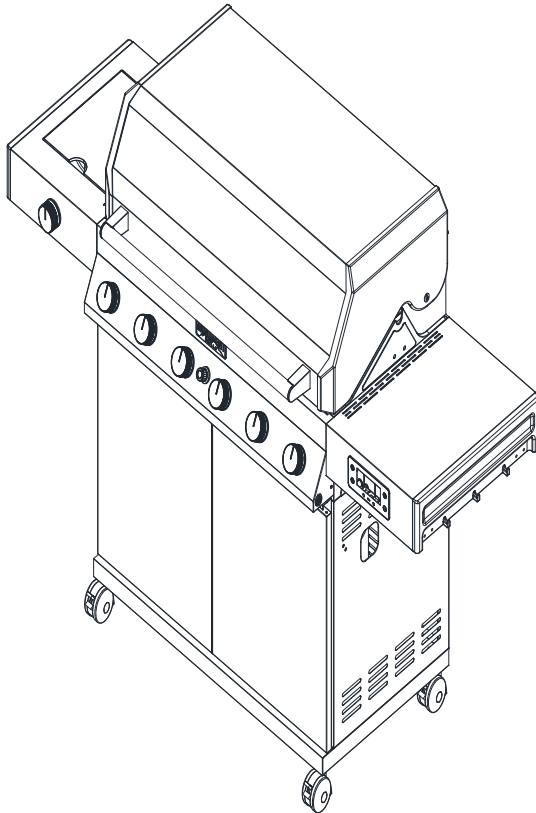

Denali 605

Liquid Propane Gas Grill



- Parts
- Assembly
- Safety Rules
- Use and Care
- Troubleshooting

WARNING:

Read this Owner's manual carefully and be sure your gas grill is properly assembled, installed and maintained. Failure to follow these instructions could result in serious injury and/or property damage. This gas grill is intended for outdoor use only and is not intended to be installed in or on recreational vehicles or boats.

Note to Installer

Leave this Owner's Manual with the customer after delivery and/or installation.

Note to Consumer

Leave this Owner's Manual in a convenient place for future reference.

Customer Service Helpline:

For parts ordering, call:
1-800-530-9133

MFG No.: D605

Please make sure the cylinder valve connection device shall properly and safely mate with the connection device attached to the inlet of the pressure regulator.

C045257-A3

Table of Contents

Warranty-----	2
Safety Precautions-----	3~4
Hardware List-----	5
Assembly Diagram -----	6
Assembly List-----	7
Assembly Instructions -----	8~20
Lighting Instructions -----	21~22
Digitemp Display&APP Instructions -----	23~25
Cleaning and Maintenance -----	26~27
Troubleshooting-----	27
Part Diagram-----	28
Part List-----	29
Cooking Instruction-----	30
Cooking Chart-----	31
Natural Gas Conversion-----	32~39

Grill Warranty

One-Year Full Warranty on Grill

If this grill fails due to defective material or workmanship within one year from the date of purchase, contact us to arrange for a free repair (or replacement if repair proves impossible).

8-Year Limited Warranty on Stainless Steel Burners

For eight years from the date of purchase, any stainless steel burner that rusts through will be replaced free of charge. After the first year from the date of purchase, you pay for labor if you wish to have it installed.

All warranty coverage excludes ignitor batteries and grill part paint loss, discoloration or rusting, which are either expendable parts that can wear out from normal use within the warranty period, or are conditions that can be the result or normal use, accident or improper maintenance.

All warranty coverage is void if this grill is ever used for commercial or rental purposes.

All warranty coverage applies only if this grill is used in the North America.

This warranty gives you specific legal rights, and you may have other right which vary from state to state.

The warranty is only valid for original purchasers with proof of purchase from authorized retailers. Any product bought second hand or through an unauthorized retailer, will not be covered by warranty. It is the duty of the purchaser to verify that a retailer is authorized. A purchase on Amazon or other marketplace internet retailer from any entity other than Monument Grills is not an original purchase and will not qualify for a warranty

Safety Precautions

WARNING

Combustion by products produced when using this product contain chemicals known to the State of California to cause cancer, birth defects, or other reproductive harm.

WARNING

Failure to comply with these instructions could result in a fire or explosion that could cause serious bodily injury, death, or property damage.

WARNING

Your grill will get very hot. Never lean over the cooking area while using your grill. Do not touch cooking surfaces, grill housing, lid or any other grill parts while the grill is in operation, or until the gas grill has cooled down after use.

Failure to comply with these instructions may result in serious bodily injury.

WARNING

- 1. Do not store or use gasoline or other flammable liquids or vapors in the vicinity of this or any other appliance.**
- 2. An LP cylinder not connected for use shall not be stored in the vicinity of this or any other appliance.**

DANGER

If you smell gas:

- 1. Shut off gas to the appliance.**
- 2. Extinguish any open flame.**
- 3. Open lid.**
- 4. If odor continues, keep away from the appliance and immediately call your gas supplier or your fire department.**

Grill Installation Codes

The installation must conform with local codes or, in the absence of local codes, with either the national fuel gas code, ANSI Z 223.1/NFPA S4, Natural gas and propane installation code, CSA B149.1, or propane storage and handling code, B149.2, or the standard for Recreational vehicles, ANSI A 119.2, and CSA Z240 RV series recreational vehicle code, as applicable.

LP gas grill models are designed for use with a standard 20 lb. Liquid Propane Gas tank, not included with grill. Never connect your gas grill to an LP gas tank that exceeds this capacity.

Safety Precautions

A tank of approximately 12 inches in diameter by 18-1/2 inches high is the maximum size LP gas tank to use. **You must use an OPD gas tank which offers an Overfill Prevention Device.**

This safety feature prevents the tank from being overfilled which can cause malfunction of the LP gas tank, regulator and/or grill.

The LP gas tank must be constructed and marked in accordance with specifications of the U.S. Dept. of Transportation (DOT). In Canada, the LP gas tank must meet the National Standard of Canada, Can CSA –B339, Cylinders, spheres and Tubes for Transportation of Dangerous Goods and Commission.

1. The LP gas tank must have a shutoff valve, terminating in an LP gas supply tank valve outlet, that is compatible with a Type 1 tank connection device. The LP gas tank must also have a safety relief device that has a direct connection with the vapor space of the tank.
2. Always keep LP gas tanks in an upright position. The tank supply system must be arranged for vapor withdraw.
3. The LP gas tank used must have a collar to protect the tank valve.

Proper Placement and Clearance of Grill

Never use your gas grill in a garage, porch, shed, breezeway or any other enclosed area. Your gas grill is to be used **outdoors only**, at least 24 inches from the back and side of any combustible surface. Your gas grill should not be used under overhead combustible construction. Do not obstruct the flow of ventilation air around the gas grill housing.

- Do not install this outdoor gas grill in or on recreational vehicles or boats
- Keep outdoor gas grill area clear and free from combustible materials, gasoline and other flammable vapors and liquids
- Do not obstruct the flow of combustion and ventilation air. Check for this each time prior to using grill.
- **Never** connect an unregulated LP gas tank to your gas grill. The gas regulator assembly supplied with your gas grill is adjusted to have an outlet pressure of 11" water column (W.C.) for connection to an LP gas tank.
- Only use the regulator and the hose assembly supplied with your gas grill. Replacement regulators and hose assemblies must be those specified in this manual.

- Have your LP gas tank filled by a reputable propane gas dealer and visually inspected and re-qualified at each filling.
- Do not store a spare LP gas tank under or
- Never fill the tank beyond 80 percent full. If this information is not followed exactly a fire causing death or serious injury may occur.
- Always keep LP gas tanks in an upright position.
- Do not store (or) or use gasoline or other flammable vapors and liquids in the vicinity of this gas grill.
- Do not subject the LP gas tank to excessive heat.
- Never store an LP gas tank indoors. If you store your gas grill in the garage or other indoor location, **always** disconnect the LP gas tank first and store it safely outside.



- Place dust cap on cylinder valve outlet whenever the cylinder is not in use. Only install the type of dust cap on the cylinder valve outlet that is provided with the cylinder valve. Other types of caps or plugs may result in leakage of propane.
- LP gas tanks must be stored outdoors in a well-ventilated area and out of reach of children. Disconnected LP gas tanks must not be stored in a building, garage or any other enclosed area.
- When your gas grill is not in use the gas must be turned off at the LP gas tank.
- The pressure regulator and hose assembly must be inspected before each use of the grill. If there is excessive abrasion or wear or if the hose is cut, it must be replaced prior to the grill being used again.
- Keep the gas regulator hose away from hot grill surfaces and dripping grease. Avoid unnecessary twisting of hose. Visually inspect the hose prior to each use for cuts, cracks, excessive wear or other damage.
- **Never** light your gas grill with the lid closed or before checking to ensure the burner tubes are fully seated over the gas valve orifices.
- **Never** allow children to operate your grill.

⚠ WARNING

A strong gas smell, or the hissing sound of gas indicates a serious problem with your gas grill or the LP gas tank. Failure to immediately follow the steps listed below could result in a fire or explosion that could cause serious bodily injury, death, or property damage.

- Shut off gas supply to the gas grill.
- Turn the control knobs to OFF position.
- Put out any flame with a proper fire extinguisher.
- Open Grill Lid.
- Get away from the LP gas tank.
- Do not try to fix the problem yourself.
- If odor continues or you have a fire you can not extinguish, call your fire department. Do not call near the LP gas tank because your telephone is a form of electrical device and could create a spark resulting in fire and/or explosion.

NOTE: The normal flow of gas through the regulator and hose assembly can create a humming noise. A low volume of noise is perfectly normal and will not interfere with operation of the grill. If humming noise is loud and excessive you may need to purge air from the gas line or reset the regulator excess gas flow device. This purging procedure should be done every time a new LP gas tank is connected to your grill. For help with this procedure refer to page 22, Item 4 of “If Grill Still Fails To Light”.

CAUTION: Beware of Flash-Back

CAUTION: Spiders and small insects occasionally spin webs or make nests in the grill burner tubes during transit and warehousing. These webs can lead to gas flow obstruction which could result in a fire in and around burner tubes. This type of fire is known as “FLASH-BACK” and can cause serious damage to your grill and create an unsafe operating condition for the user.

Although an obstructed burner tube is not the only cause of “FLASH-BACK”, it is the most common cause.

To reduce the chance of “FLASH-BACK”, you must clean the burner tubes before assembling your grill, and at least once a month in late summer or early fall when spiders are most active. Also perform this burner tube cleaning procedure if your grill has not been used for an extended period of time.

See Cleaning Burner Tubes and Burner Ports on page # 26

Burner Flame Check

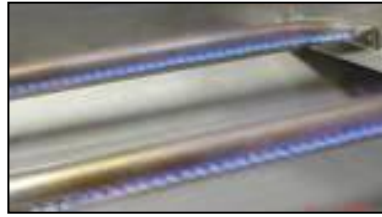







Visually check the burner flames prior to each use. The flames should look like picture, if they do not, refer to the cleaning Burner Tubes and Burner Ports, see page 26 of this manual.

⚠ WARNING

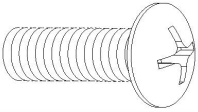
Pls ensure cleaning the flame tamer/cooking grid/grease pan/tray after each use. Failure to comply this could result in a fire or explosion that could cause serious bodily injury, death, or property damage.

Contents for Hardware Pack

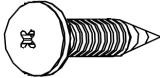
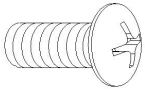
The following table illustrates a breakdown of the hardware pack. It highlights what components are used in the various stages of assembly.

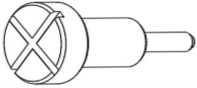
A		1/4"×15mm	12 pcs
B			5 pcs
C			2 pcs
D		1/4"	4 pcs
E		ST4.2×9.0	15 pcs
F		5/32"×12mm	13 pcs
G			2 pcs
H		1/4"-20UNC	2 pcs

Tools required for assembly

Phillips Head Screwdriver (not included).

Note: The left and right sides of the grill are on your left and right as you face the front of the grill.

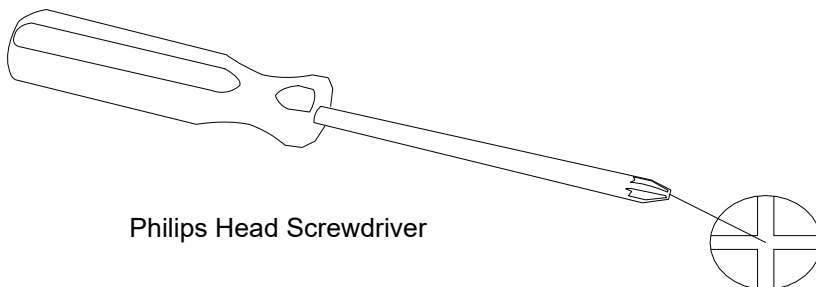

Model Denali 605 Assembly Diagram

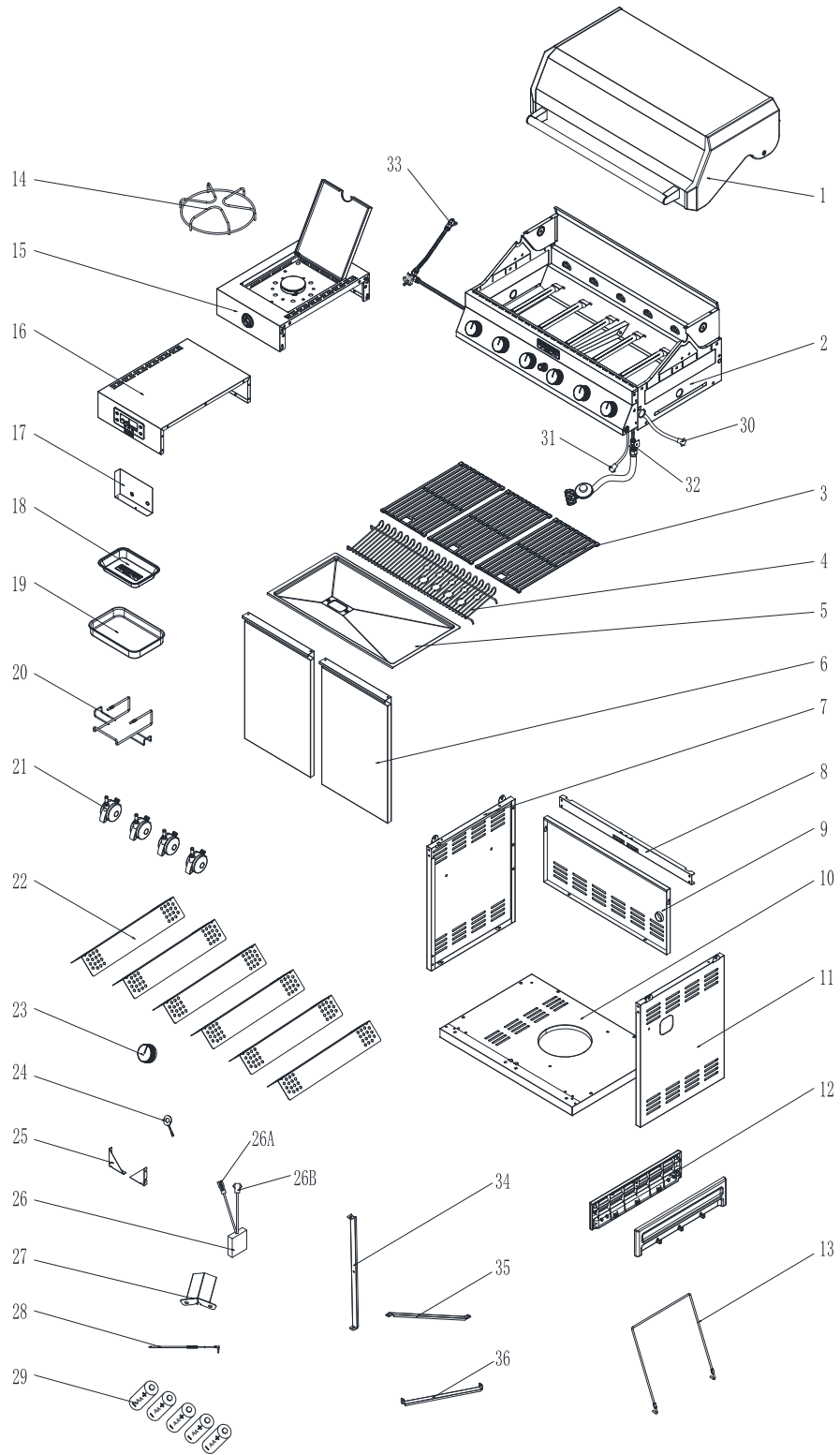

Model Denali 605 Assembly List

seq. NO.	appellation	seq. NO.	appellation
1	Main Lid	20	Grease Box Bracket
2	Fire Box	21	Locking Caster
3	Cooking Grid With Hole	22	Flame Tamer
4	Warming Rack	23	Control Knob
5	Grease Tray	24	LED knob light Panel
6	Cabinet Door	25	Triangle Bracket
7	Cabinet Side Panel,Left	26	Battery Box
8	Cart Frame, Front	26A	Battery Box female
9	Back Panel, Bottom	26B	Battery Box male
10	Cart Bottom Shelf	27	Temperature Sensor Cover
11	Cabinet Side Panel,Right	28	Meat Probe
12	Side Shelf End Cap	29	Battery
13	Gas-jar Fixing Line	30	Fire Box Temperature Sensor Wire
14	Side Burner Cooking Grid	31	Knob Light Panel Wire
15	Side Shelf,Left	32	Valve Converter Bracket
16	Side Shelf,Right	33	Side Burner Nozzel Seat
17	Display Screen Baffle	34	Gas Cylinder Heat Shield,Post
18	Foil Tray	35	Gas Cylinder Heat Shield,Above
19	Grease Box	36	Gas Cylinder Heat Shield,Middle

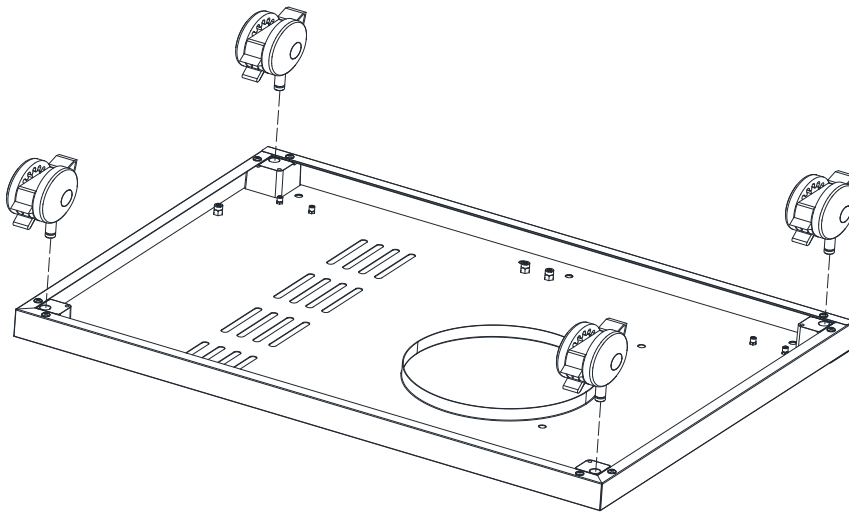

Please insert Locking Caster(No.21) into the bottom plate(No.10).

Figure 1

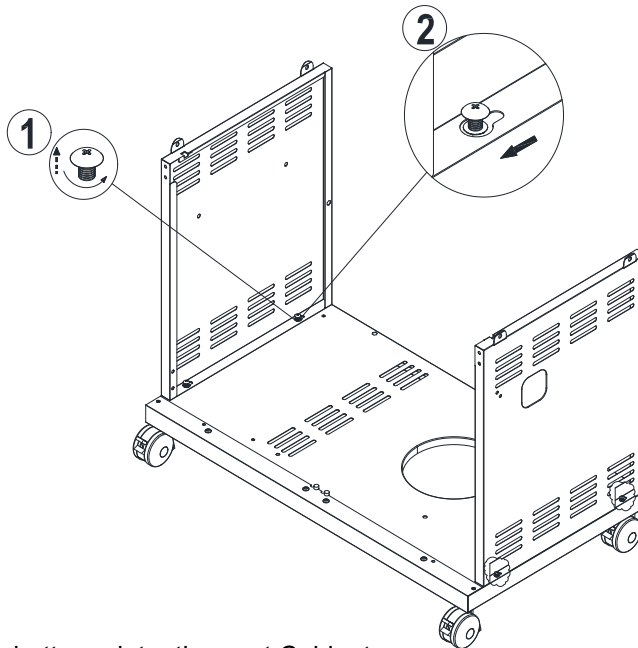

Half screw out the screws in the bottom plate, then put Cabinet Side Panel,Left(No.7) and Cabinet Side Panel,Right(No.11) onto the relevant screw holes and screw tightly.

Figure 2

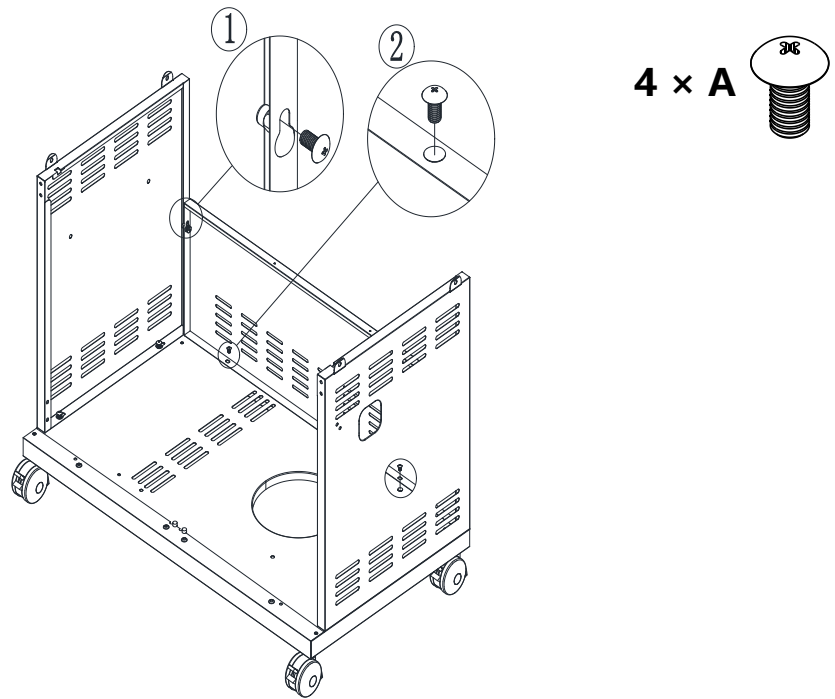

Install Back Panel, Bottom(No.9) onto the relevant place with four A screws.

Figure 3

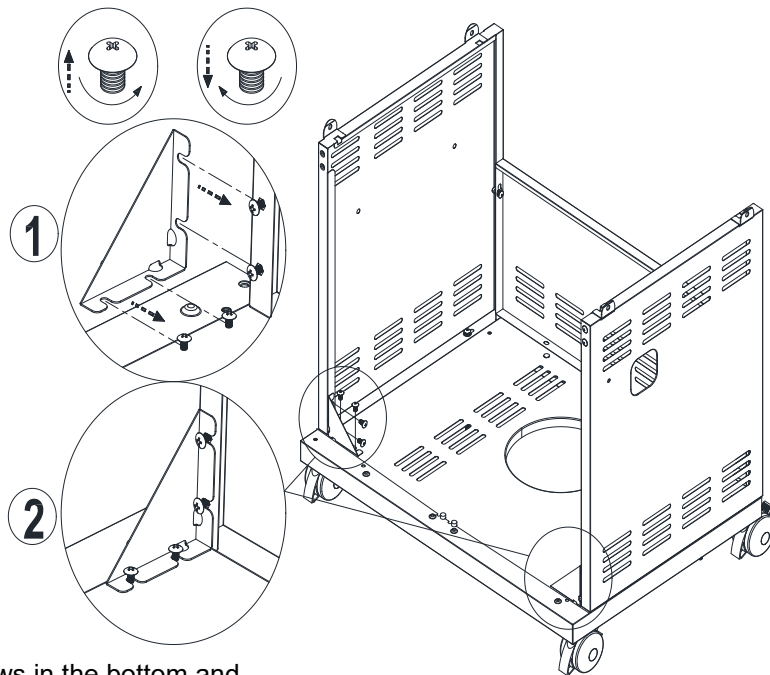

Half screw out the screws in the bottom and side plates, then put Triangle Bracket(No.25) onto the relevant screw holes and screw tightly.

Figure 4

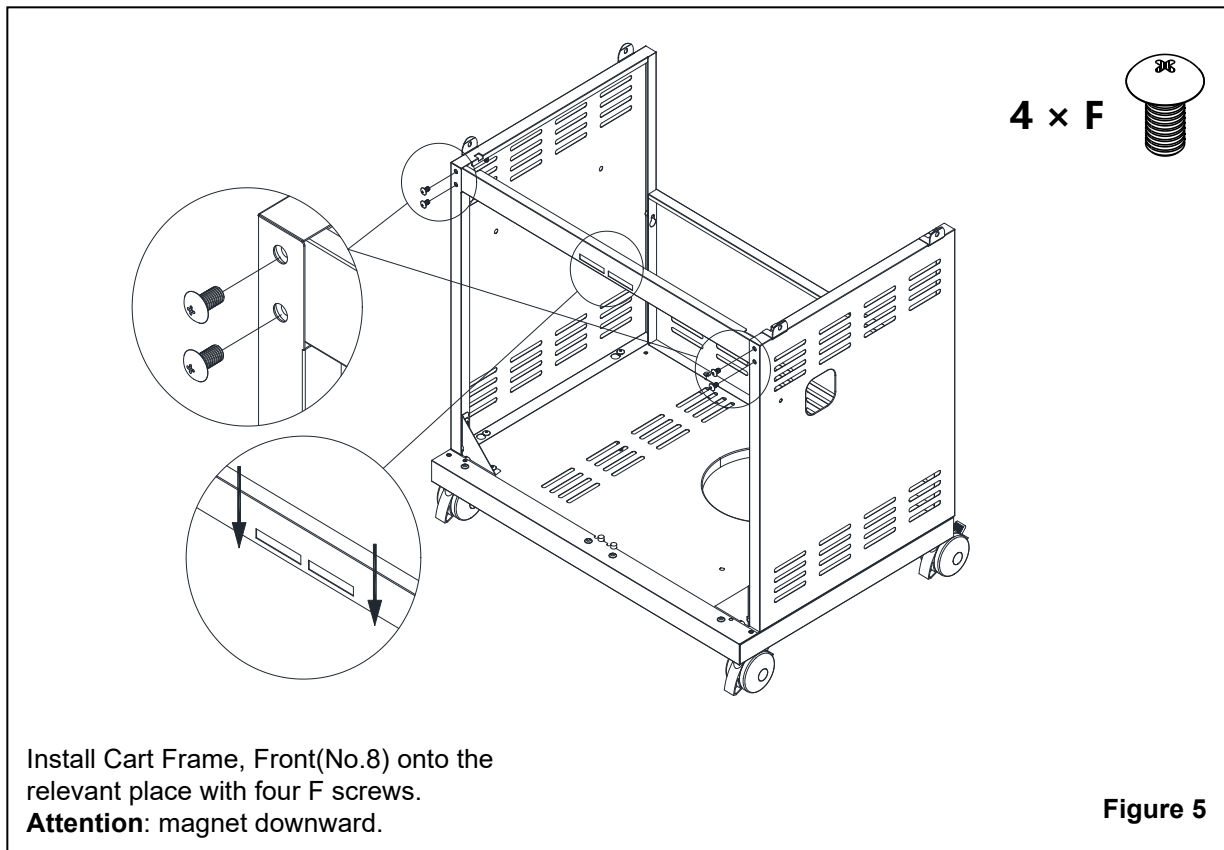

Figure 5

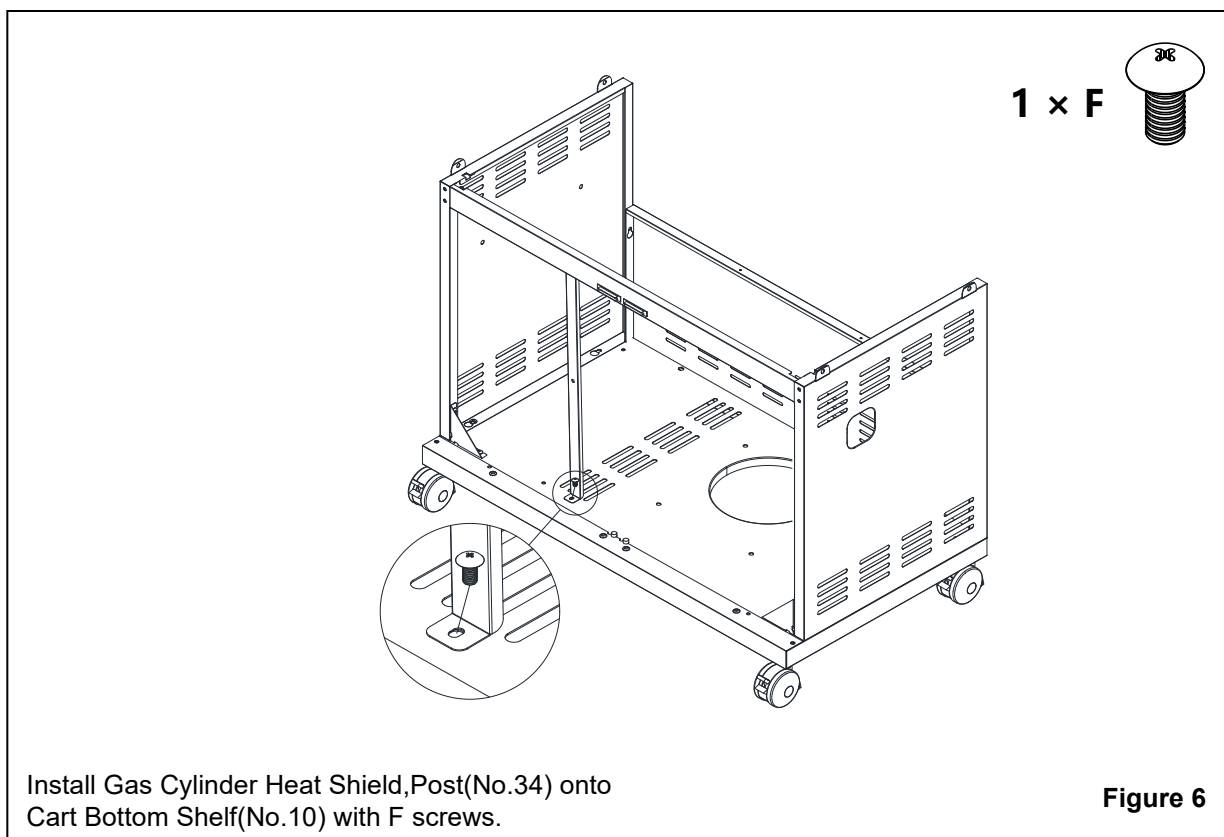
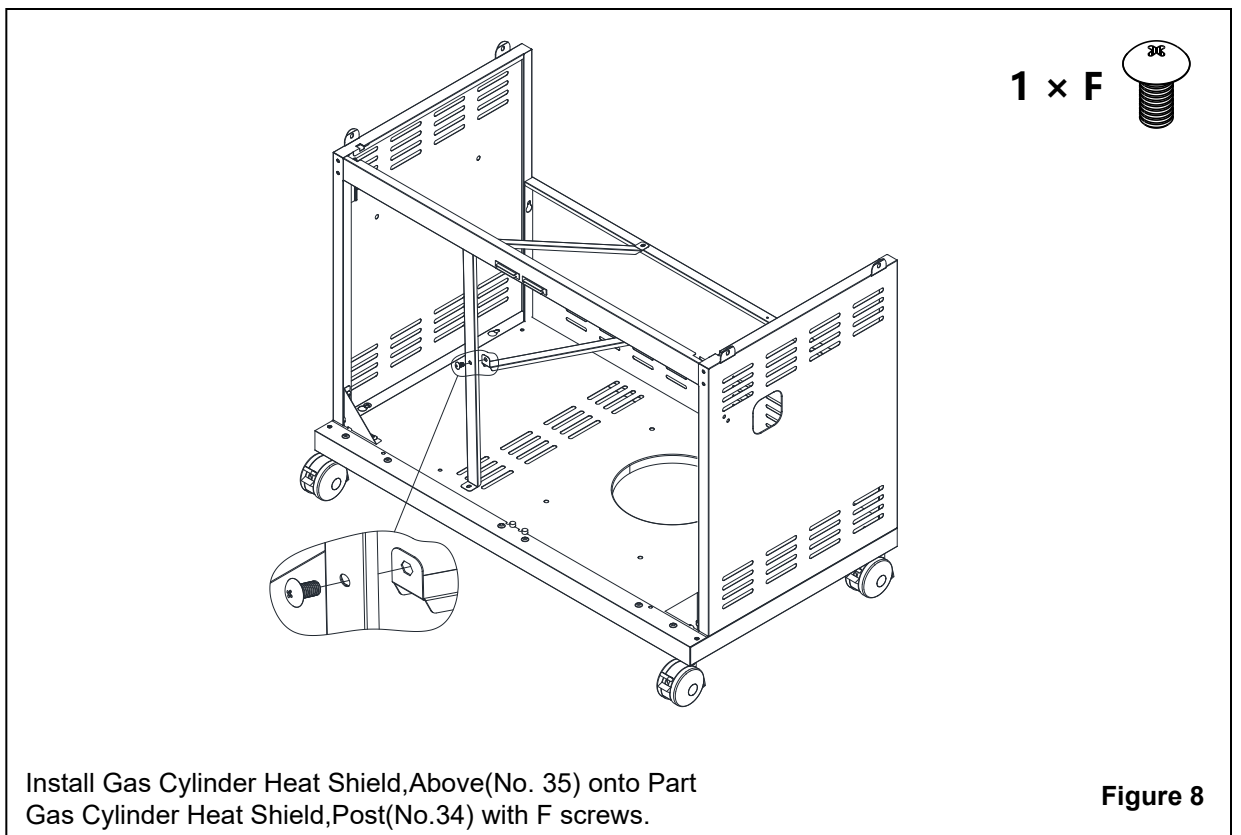
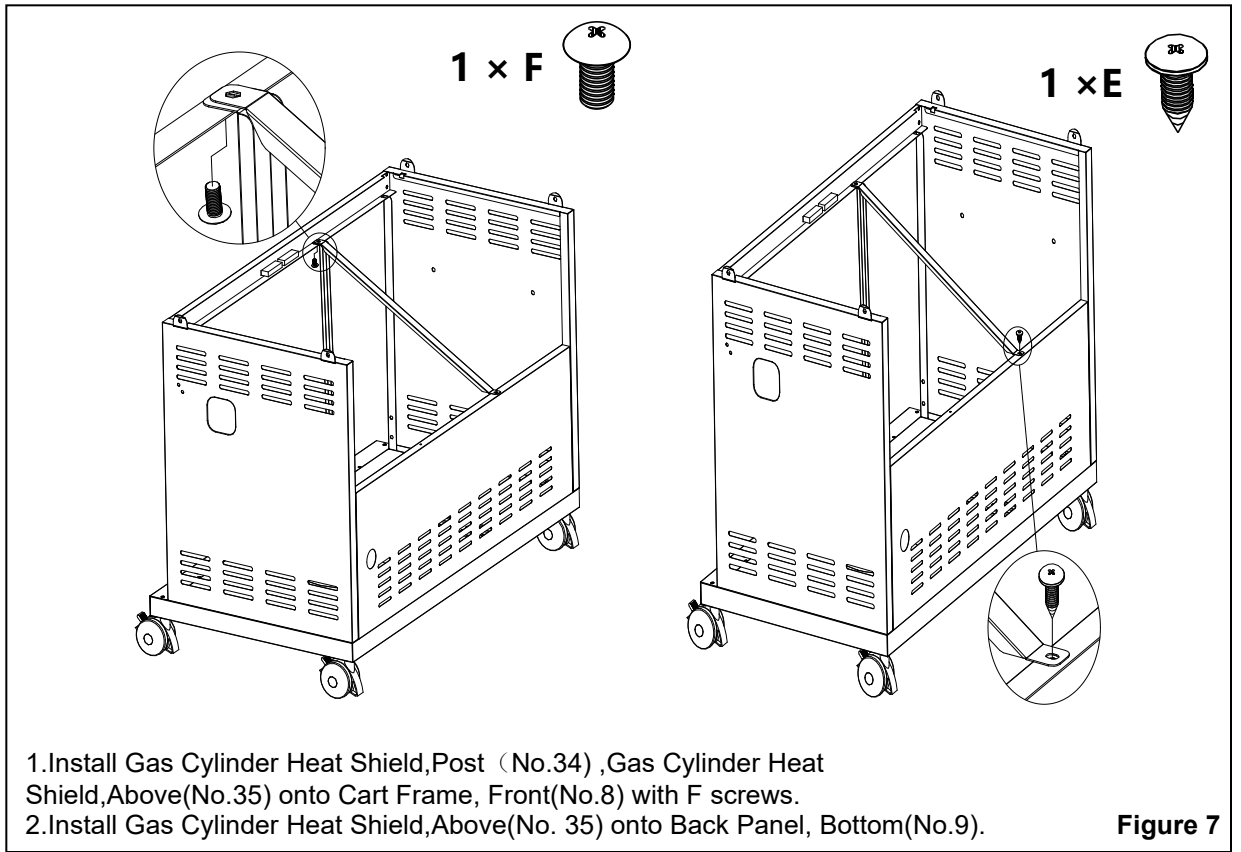
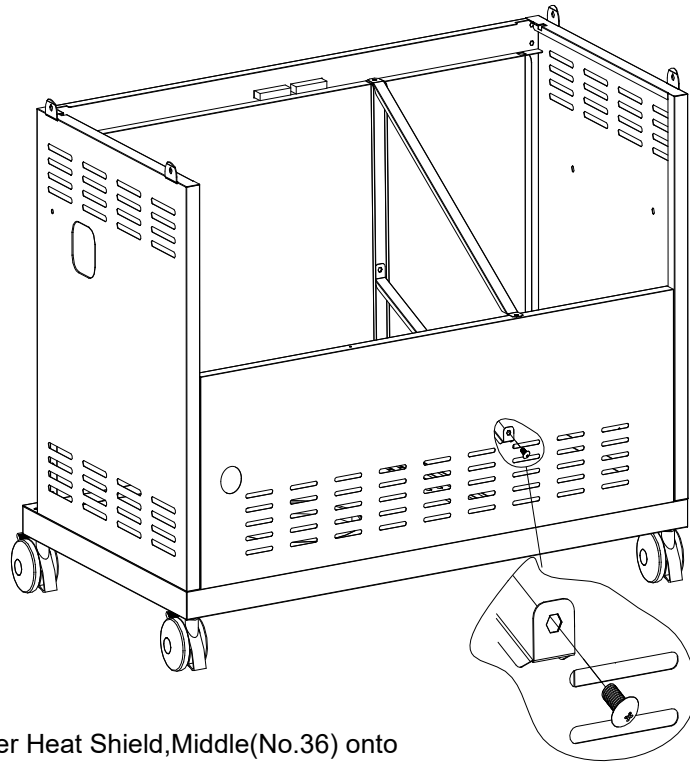

Figure 6





Install Gas Cylinder Heat Shield, Middle (No.36) onto Back Panel, Bottom (No.9) with F screws.

Figure 9

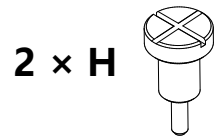
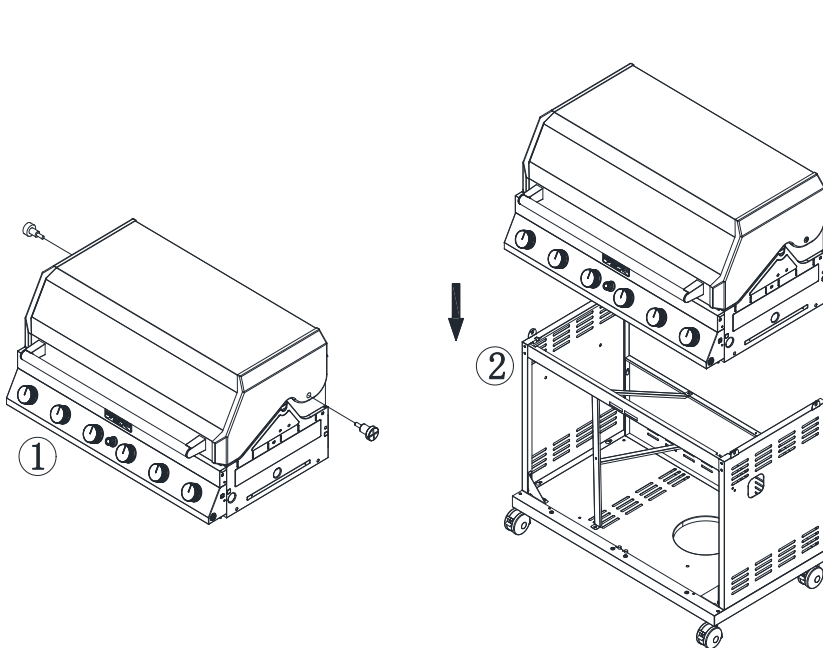

1: Install main lid to firebox with Fire Box (No.2).
2: Put the assembly of firebox & main lid onto the grill cart.

Figure 10

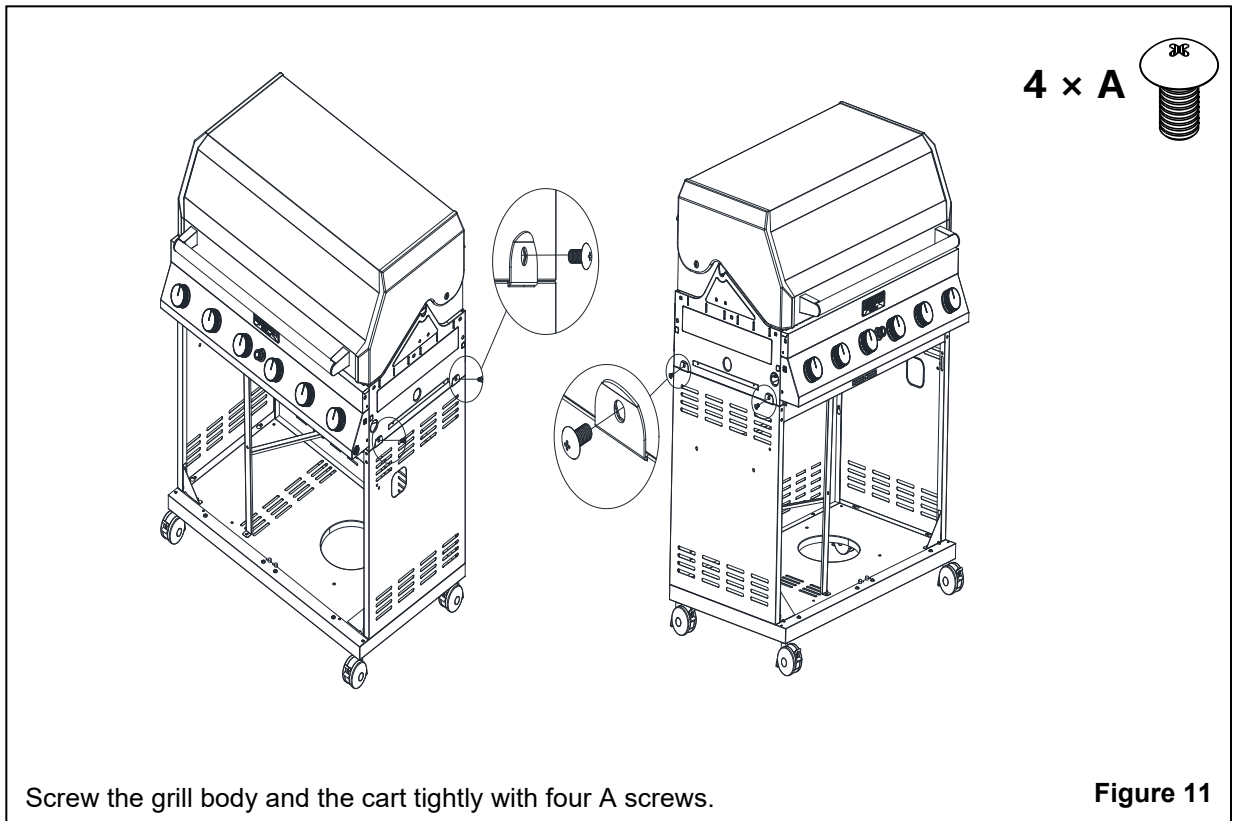

Screw the grill body and the cart tightly with four A screws.

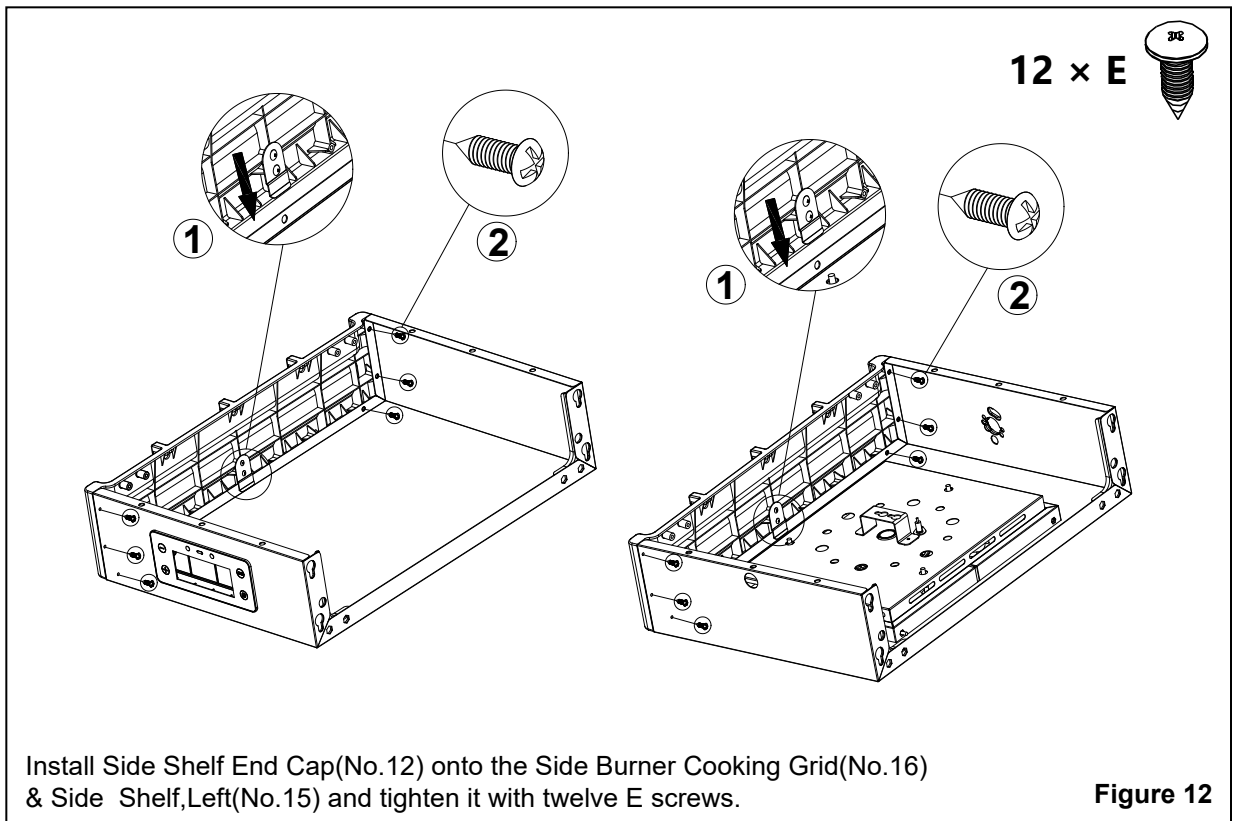

Install Side Shelf End Cap(No.12) onto the Side Burner Cooking Grid(No.16) & Side Shelf,Left(No.15) and tighten it with twelve E screws.

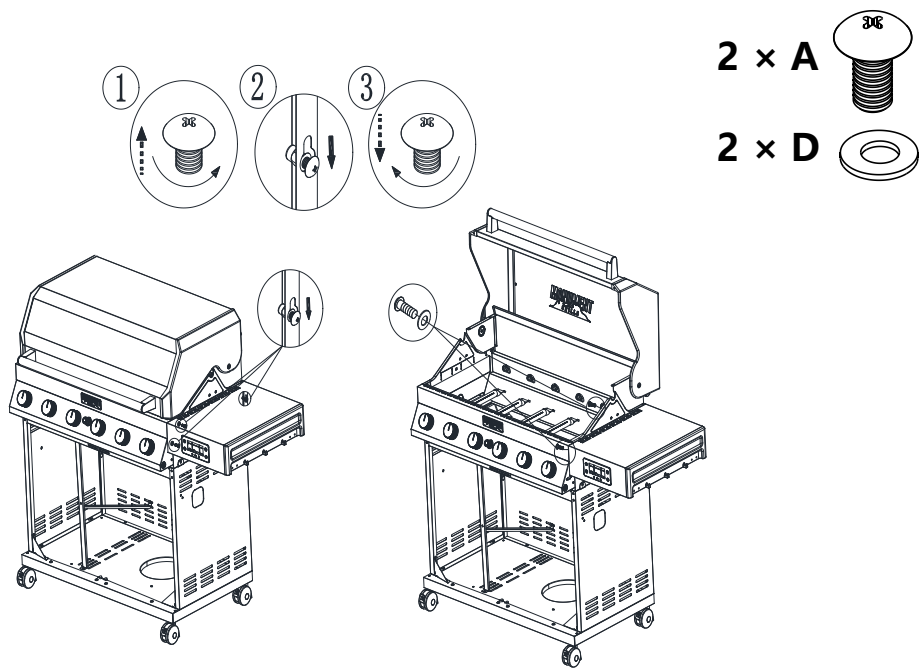

1. Half screw out the three big screws on the grill body, then put Side Shelf,Right(No.16) onto the relevant screw holes and screw tightly.
2. Screw Side Shelf,Right(No.16) tightly with A screw and D spacer inside the grill body.

Figure 13

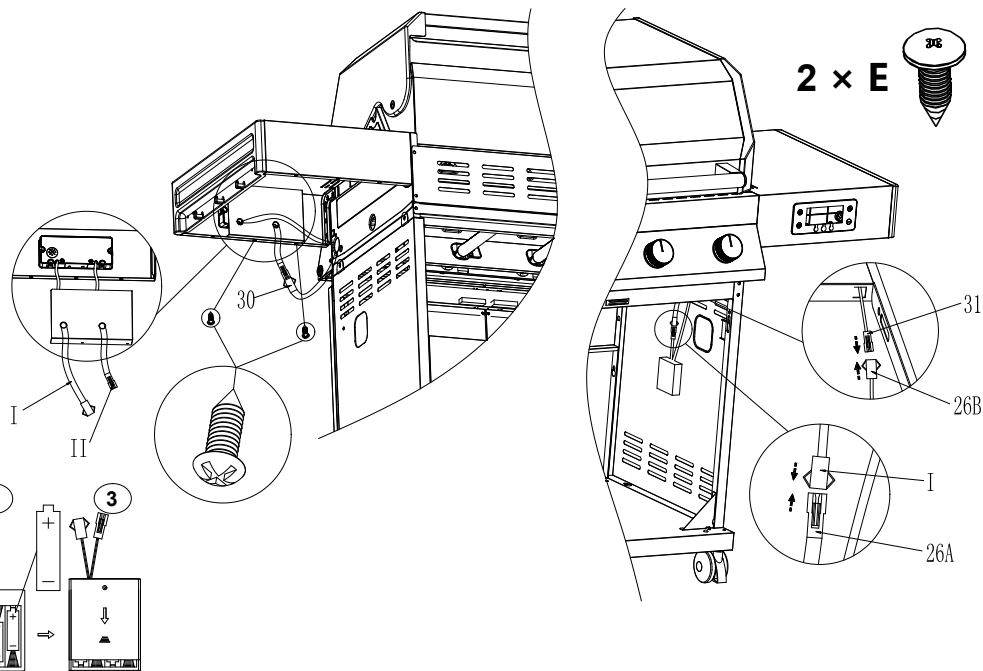

1. Install Display Screen Baffle(No.17) onto Side Shelf,Right(No.16) and tighten it with two E screws.
2. Connect Battery Box female(No.26A) with I, Battery Box male(No.26B) with Knob Light Panel Wire(No.31) and Fire Box Temperature Sensor Wire(No.30) with II.

Figure 14

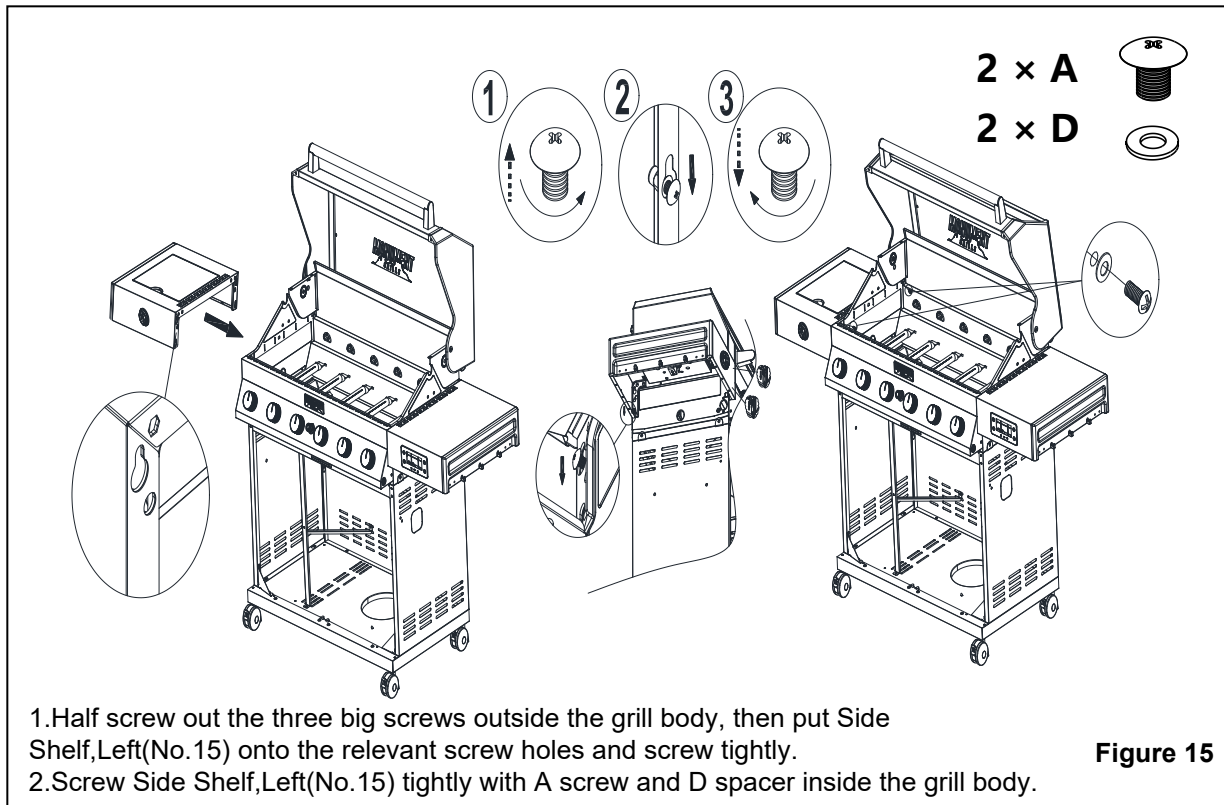

Figure 15

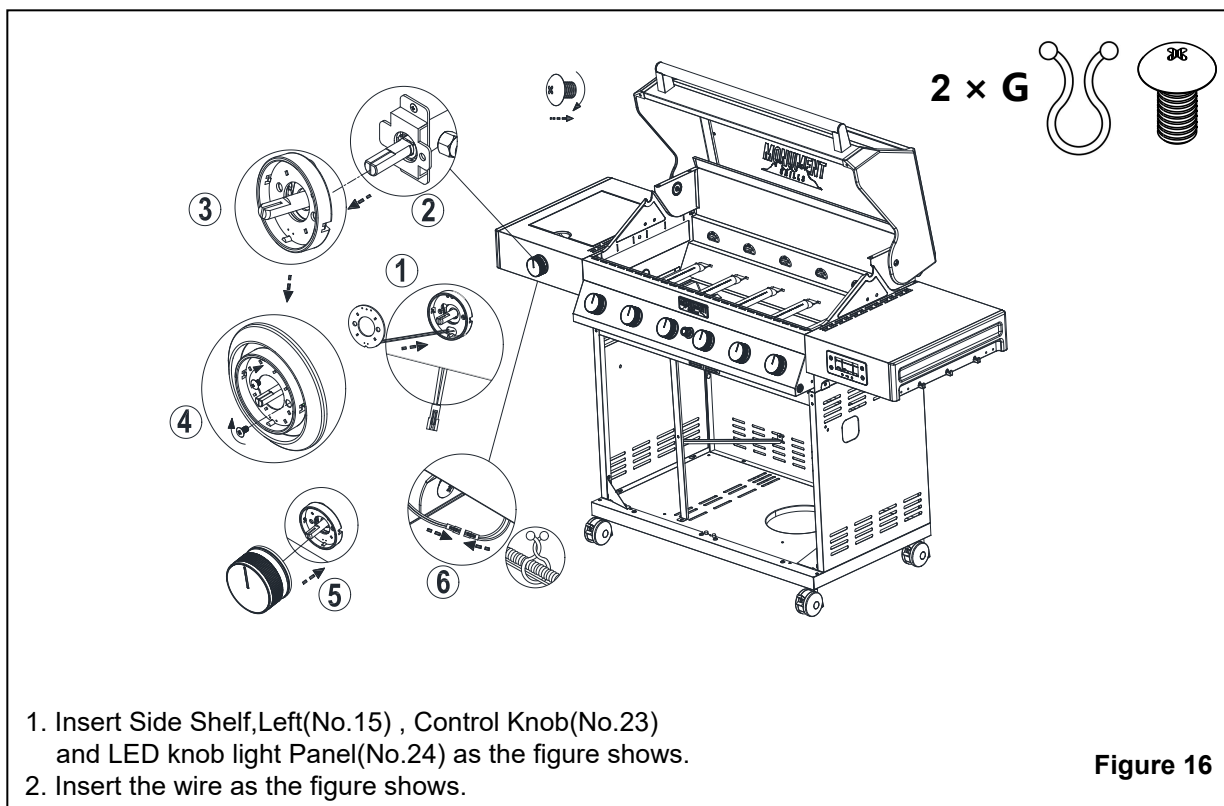
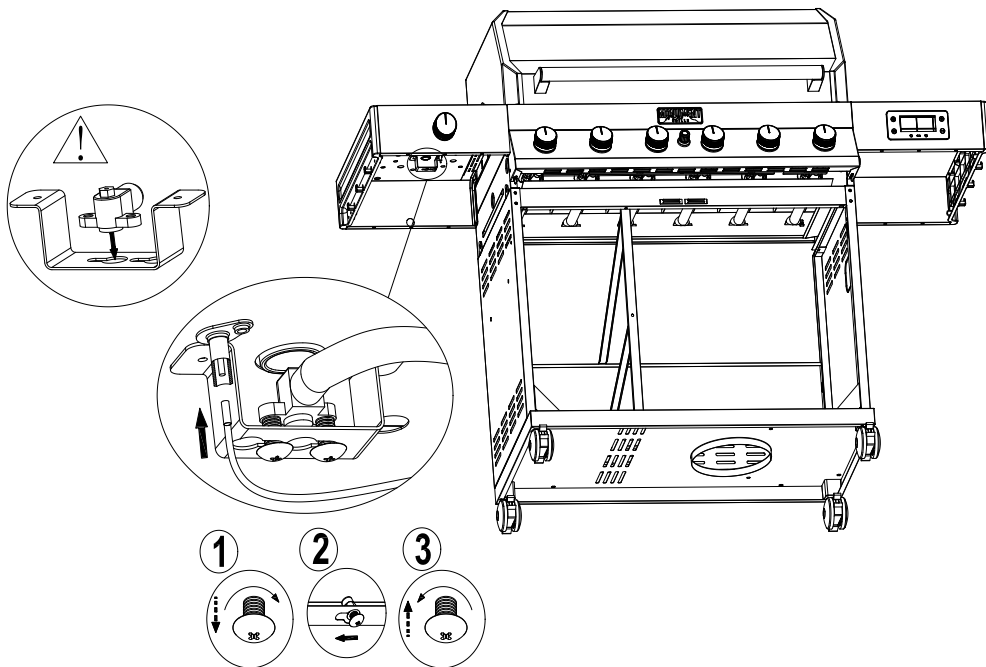
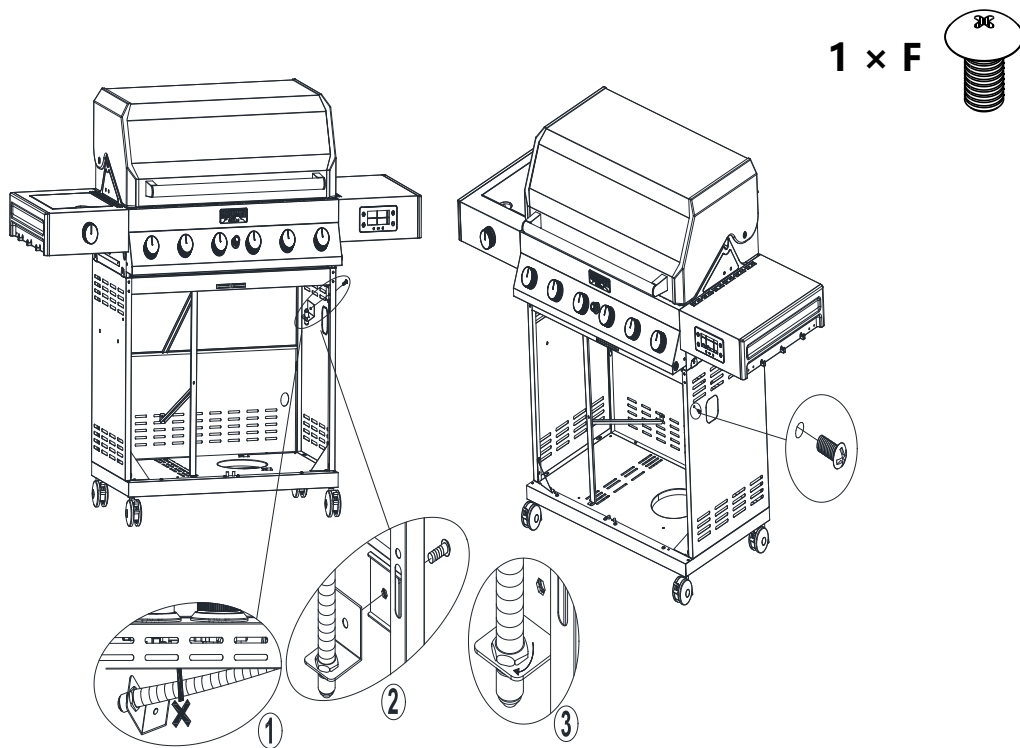

Figure 16



Half screw out the screw in Side Burner Nozzel Seat(No.33), then put it into the hole of Side Shelf,Left(No.15) and screw tightly.

Figure 17



Fixed Valve Converter Bracket(No.32) onto the right plate with one F screw.

Figure 18

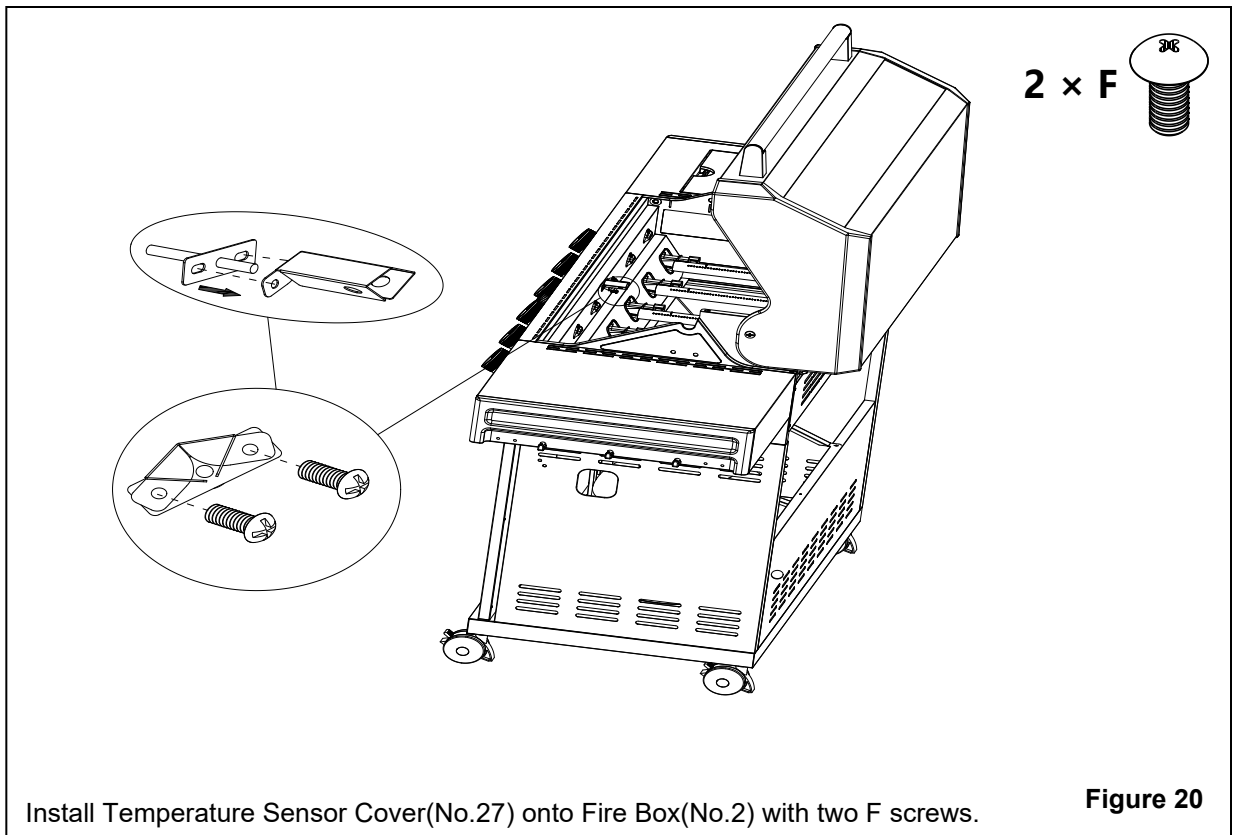
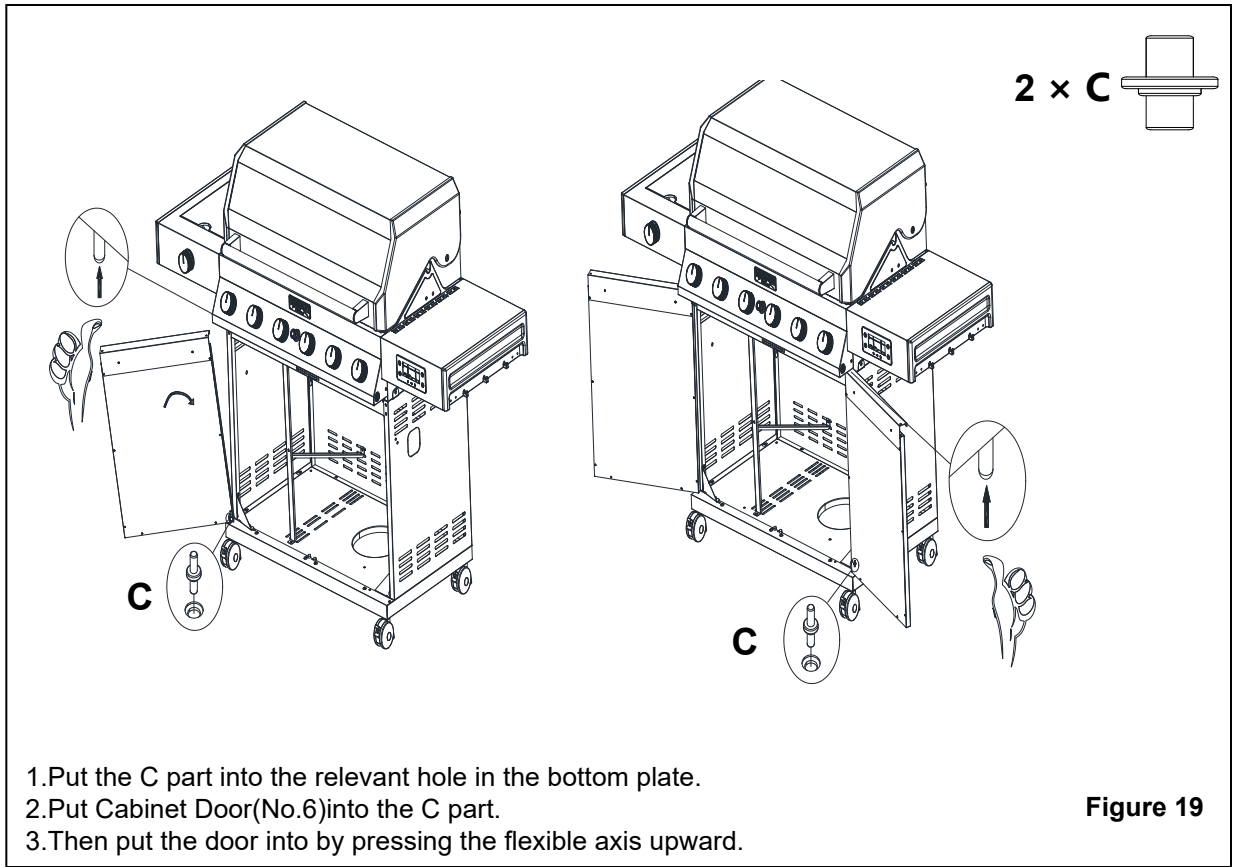

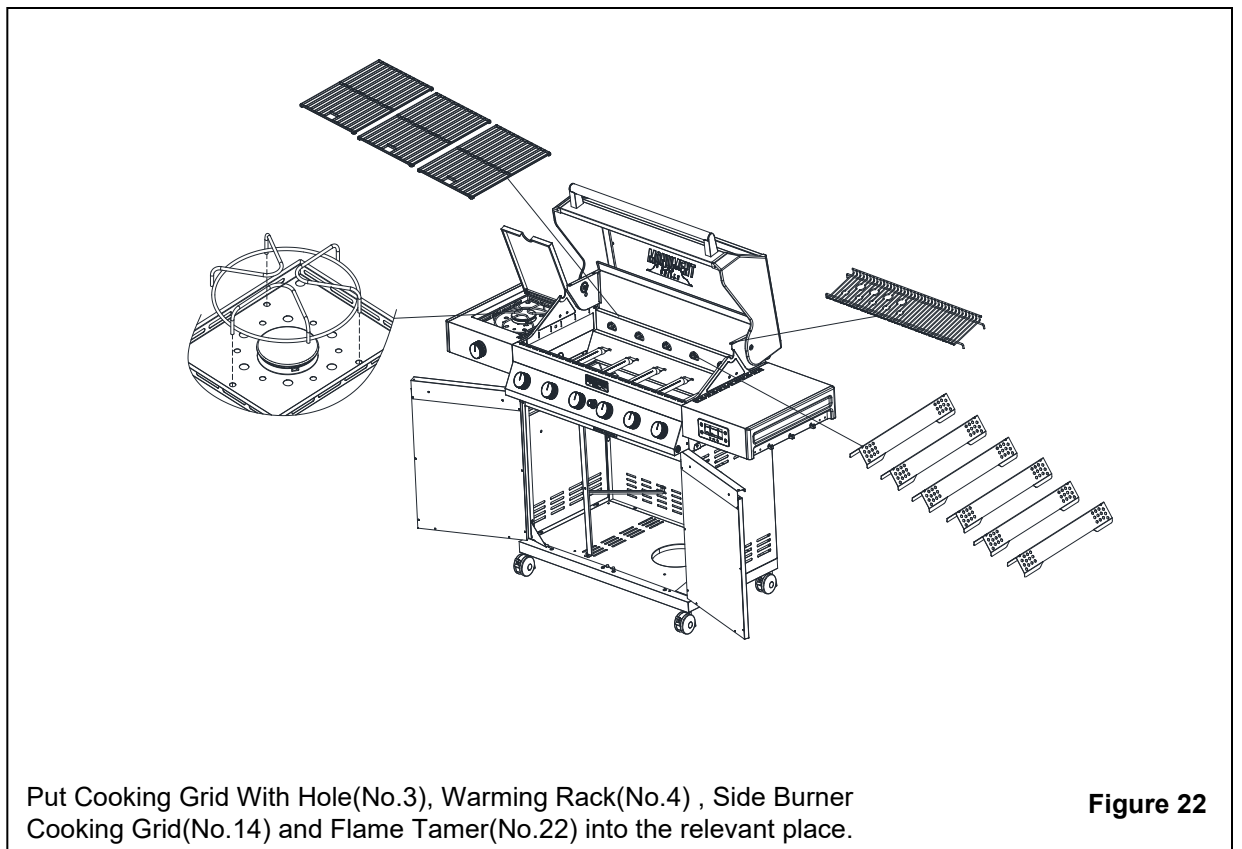
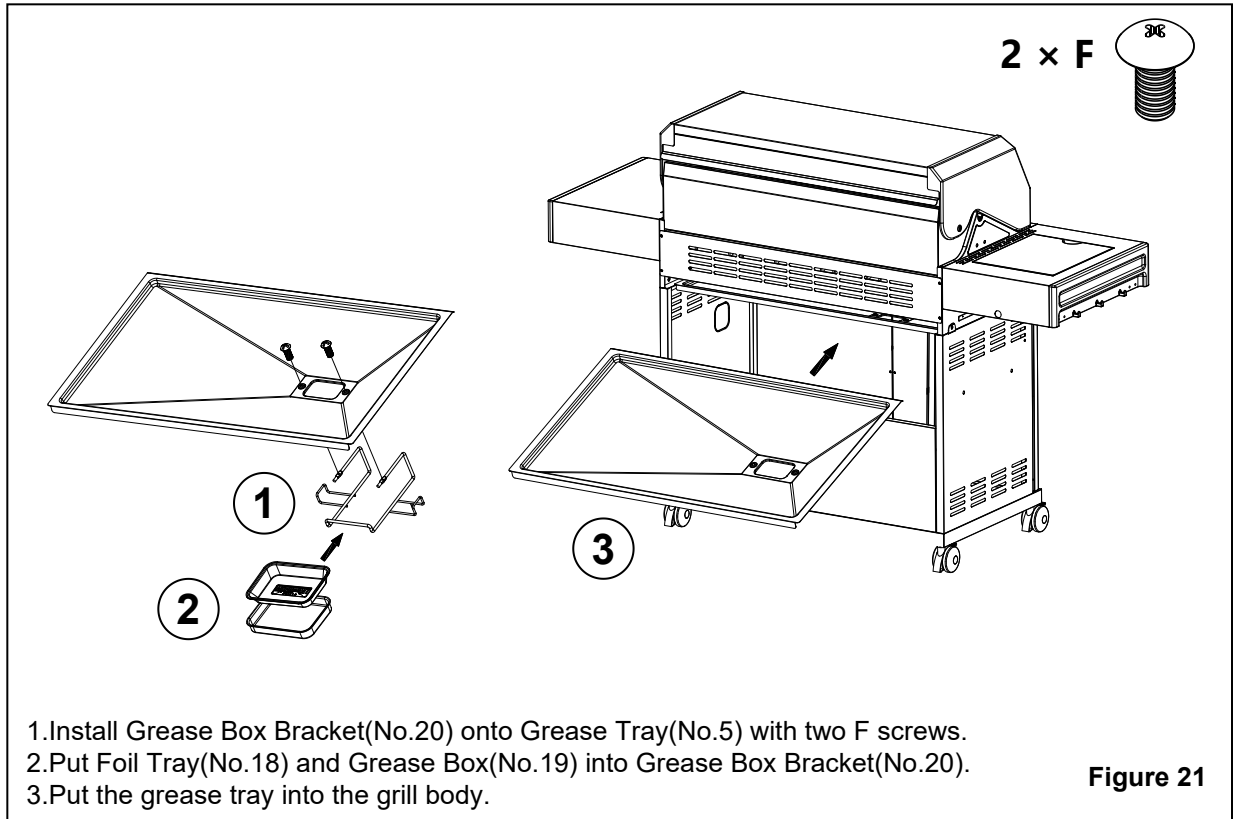

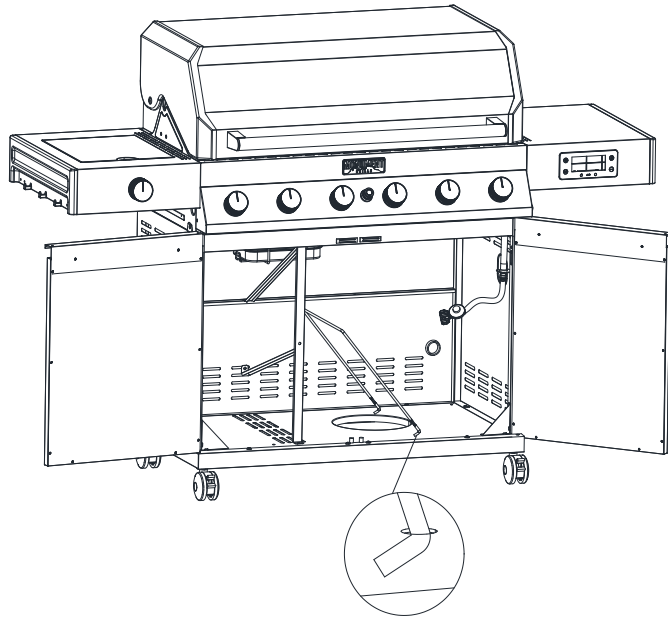

Install Gas-jar Fixing Line(No. 13) onto the bottom plate.

Figure 23

Connecting LP Gas Tank to LP Grill

1. Place foot ring of 20 lb tank into the hole in bottom panel. Make sure the tank valve is in OFF position.(Fig.25).
2. Check the tank valve to ensure it has proper external mating threads to fit the hose and regulator assembly provided.
3. Make sure all burner valves are in OFF position.
4. Inspect the valve connection port and regulator assembly. Look for damage or debris. Remove any debris. Inspect hose for damage. Never use damaged or plugged equipment.
5. When connecting regulator and hose assembly to tank valve hand tighten quick coupling nut clockwise to a full stop (Fig.24) Do not use a wrench to tighten because it could damage the quick coupling nut and result in a hazardous condition.
6. Open tank valve fully (counterclockwise). Use a soapy water solution to check all connections for leaks before attempting to light your grill. If a leak is found, turn tank valve off and do not use your grill until the leak is repaired.

CAUTION: When the appliance is not in use, gas must be turned off at the supply tank.

Regulator Connection

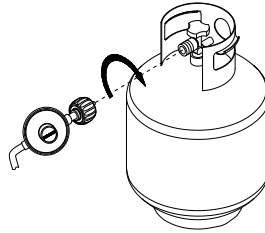

Figure 24

Congratulations

Your gas grill is now ready for use. Before the first use and at the beginning of each season (and whenever the LP gas tank has been changed):

1. Read all safety, lighting and operating instructions.
2. Check gas valve orifices, burner tubes and burner ports for any obstructions.
3. Perform gas leak check according to instructions found on next page of the manual.

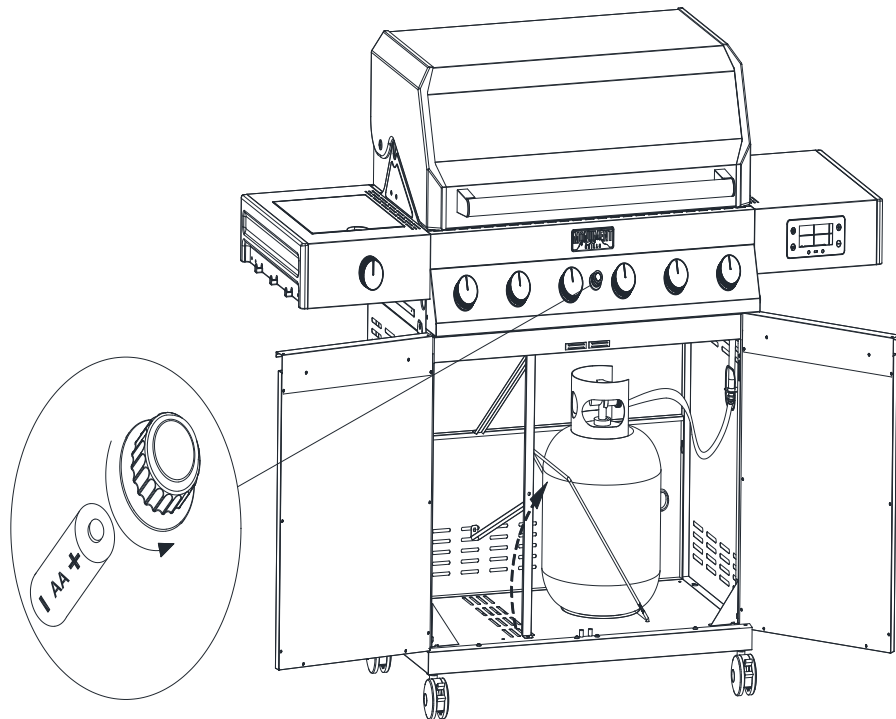

Figure 25

Checking for LP gas leaks

Never test for leaks with a flame. Prior to first use, at the beginning of each season, or every time your LP gas tank is changed, you must check for gas leaks.

1. Make a 50/50 (soap/water) mild soap solution.
2. Turn the control knobs to full OFF position. then turn gas ON at supply tank.
3. Apply the soap solution with a clean brush to all gas connections. See below. If growing bubbles appear in the solution the connections are not properly sealed. Check each fitting and tighten or repair as necessary.

Gas Connection Leak Check

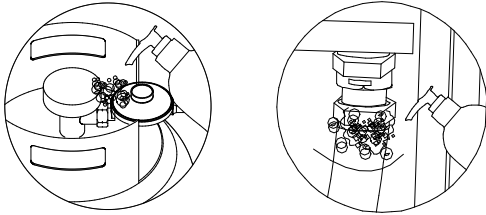

4. If you have a gas connection leak you cannot repair, turn gas OFF at supply tank, disconnect fuel line from your grill or contact your gas supplier for repair assistance.
5. Also apply soapy solution to the tank seams. See below. If growing bubbles appear, shut tank OFF and do not use or move it! Contact an LP gas supplier or your fire department for assistance.

Gas Tank Leak Check

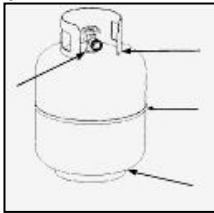

Grill Lighting Instruction

Grill Lighting Instructions for Main Burners

1. Do not smoke while lighting grill or checking gas supply connections.
2. Be sure that LP gas tank is sufficiently full.
3. Be sure all gas connections are securely tightened.
4. Turn on gas supply
5. Open the grill main lid and side burner lid.
6. Push and turn any main burner knob to MAX.



WARNING

Failure to open grill lid during the lighting procedure could result in a fire or explosion that could cause serious bodily injury, death, or property damage.

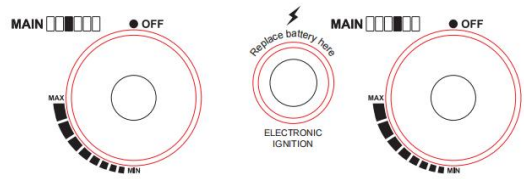

7. If the burner does not light after 5 seconds, turn knob to OFF. Turn gas OFF at LP tank and wait 5 minutes for gas to clear. Then turn gas ON at tank and repeat step 6.
8. If burner still does not light, see Match Lighting section and If Grill Still Fails to Light section on following page.

USING THE SIDE BURNER

Inspect the gas supply hose prior to turning the gas "ON". If there is evidence of cuts, wear or abrasion, it must be replaced prior to use. Do not use the side burner if the odor of gas is present.

WARNING: Always keep your face and body as far away from the burner as possible when lighting.

LIGHTING INSTRUCTIONS FOR SIDE BURNER

1. Open side burner lid fully.
2. Push and turn side burner knob to IGNITE/HI position. At the same time, press and hold electronic ignition button for 3 to 5 seconds to light burner.
3. If the side burner does not light after 5 seconds, turn knob to OFF. Turn gas OFF at LP tank and wait 5 minutes for gas to clear. Then turn gas ON at tank and repeat step 2.
4. If burner still does not light, see Match Lighting section and If Grill Still Fails to Light section on following page.



⚠ WARNING

Never lean over the grill cooking area while lighting your gas grill. Keep your face and body a safe distance (at least 18 inches) from the cooking grid surface when lighting your grill by match.

Manually Lighting Your Grill by Match

1. Take the manual lighting stick.
2. Insert a match into the lighting stick.
3. Follow steps 1 through 5 of the Basic Lighting Procedure.
4. Light the match and extend the lighting stick to cooking grid surface.
5. Turn the desired control knob to the HI/position setting to release gas. The burner should light immediately.



⚠ WARNING

Should a “FLASH-BACK” fire occur in/or around the burner tubes, follow the instructions below. Failure to comply with these instructions could result in a fire or explosion that could cause serious bodily injury, death, or property damage.

- Shut off gas supply to the gas grill.
- Turn the control knobs to OFF position.
- Put out any flame with a proper fire extinguisher.
- Open grill lid.
- Once the grill has cooled down, clean the burner tubes and burners according to the cleaning instructions found on page 26.

If Grill Still Fails To Light

1. Check gas supply and connections for leaks. Check that all wire connections are secure.

2. Repeat basic lighting procedure. If your grill still fails to operate, turn the gas off at source, turn the control knobs to OFF, then check the following:

- Misalignment of burner tubes over orifices.
Correction: Reposition burner tubes over orifices.
- Obstruction in gas line.
Correction: Remove fuel line from grill. Do not smoke! Open gas supply for 1 second to clear any obstruction from fuel line. Close off gas supply at source and reconnect fuel line to grill.
- Plugged orifice.
Correction: Remove burners from grill, carefully lift each burner up and away from gas valve orifice. Remove the orifice from gas valve and gently clear any obstruction with a fine wire. Then reinstall all orifices, burners, and cooking components.

3. If an obstruction is suspected in gas valves, please contact us.

4. If the grill still does not light you may need to purge air from the gas line or reset the regulator excess gas flow device. **Note:** This procedure should be done every time a new LP gas tank is connected to your grill.

To purge air from your gas line and/or reset the regulator excess gas flow device:

- Turn the control knob to OFF position.
- Turn off the gas at the tank valve.
- Disconnect regulator from LP gas tank.
- Let unit stand for 5 minutes.
- Reconnect regulator to the LP gas tank.
- Turn the tank valve on slowly until ¼ to ½ open.
- Open the grill lid.
- Set control knobs to OFF. Push and turn any control knob to HIGH.
- Turn control knobs to HIGH until all the burners are lit
- You may start to use the grill.

Monument Digitemp Display Instructions

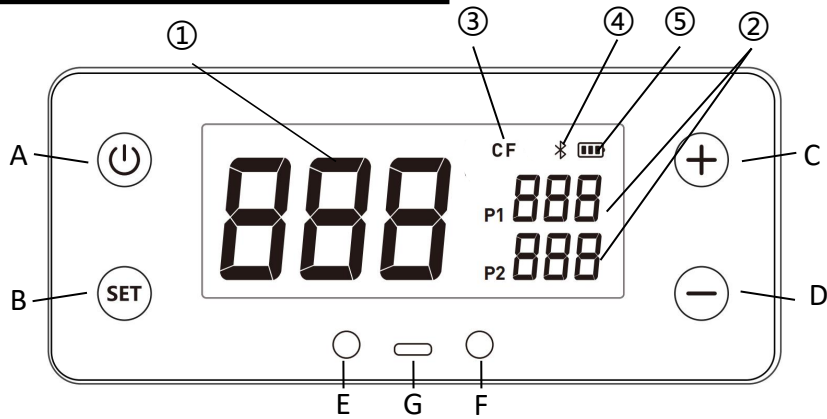

Power Button

Short Press power button  to turn on and turn off the Digitemp Display.





Setup Button

- Short press **SET** to shift meat probe 1 and 2.
- Press **SET** for 2 seconds to shift °C or °F.





Temperature Increase Button

- Short press  to increase the target temperature of meat probe, each press adds 1.8°F.
- Long press  to increase the target temperature continuously.



Temperature Decrease Button

- Short press  to decrease the target temperature of meat probe, each press subtracts 1.8°F.
- Long press  to decrease the target temperature continuously.



Meat Probes Plug

Monument Digitemp can handle up to two separate meat temperature probes (one probe included) to gain superior control of your grill for perfect results every time.



Type-C USB Socket

The Type-C USB Socket allows you to connect mobile charging power bank for power supply.

Display Icons

① Firebox Temperature Display

This area displays real-time firebox temperature .

② Meat Probe Temperature Display

This area displays real-time meat probe temperature while the probe is inserted. Without probe inserted, the display will be shown as “---”.

③ CF

Celcius and Fahrenheit Dgree

Press **SET** for 2 seconds to shift °C or °F display.



Bluetooth Connection Status

Bluetooth icon  is flashing while not connected to the APP, and will be stable after connect to the APP.



Battery Gauge

Battery gauge will show the battery level with the three bars, Without any bar and the frame will flash to remind you to replace battery.

Monument Digitemp Display Instructions

1. Turn on the Display

Short press power button  to turn on Digitemp Display while Display is off.

2. Shift Temperature in Celsius or Fahrenheit

Press setup button **SET** for 2 seconds to choose the temperature mode in Celsius or Fahrenheit. Once it is setup, the temperature mode will be fixed in one mode until you setup again.

3. Setup Meat Probe Temperature

Insert the meat probe into the plug, and short press setup button **SET** to set the target temperature.

- After the first press, the temperature icon for P1 $P1 \ 888$ will be flashing.
- After the second press, the temperature icon for P2 .
- Increase or decrease the target temperature by press $P2 \ 888$ or \oplus button: each short press adds or deducts 1.8°F, while long press \ominus to increase or decrease the target temperature continuously. The temperature range of meat probe is 104°F-212°F.
- The third press will confirm all the setup.
- There will be a beep when the meat temperature is reached to the target temperature.

4. Screen Saver

The screen will sleep after 120 seconds without any operation. The screen will be waken up by press any button.

5. Turn off the Display

Short Press power button  to turn off Digitemp Display while Display is on.

6. Bluetooth and App Connection

- Scan the QR code below and download the APP (Monument Grills) ,or search "Monument Grills" in APP store.
- After download the APP, initiate Bluetooth function of your phone, meanwhile turn on the Digitemp Display on the grill.
- Open the APP, click orange "Add Device" button, the APP will search Monument smart Grills nearby (Step 1).
- A grill icon will be shown below "Discovering devices" after the smart grill is detected by the APP, click the orange "Add" button to the next step(step 2).
- Click the blue icon \oplus to confirm adding the grill (step 3).
- There will be a green tick above the grill to indicate the grill is adding successfully, and click Done" on the upright corner to go to next step. You can rename the grill in this page with the grey pen icon at the right side of the grill (step 4).
- The real-time temperature is shown in this page, and you can adjust probe temperature or select the recipe you would like to use, detail in next page(step 5).

***Bluetooth range:** in empty flat area without any obstacle, the bluetooth range is 115 feet. and the range will be 10 feet with a wall or other similar obstacle. However, maximum communication range will vary depending on obstacles(person, metal, wall, etc.) or electro-magnetic environment.



<https://a.smart321.com/commobunent>

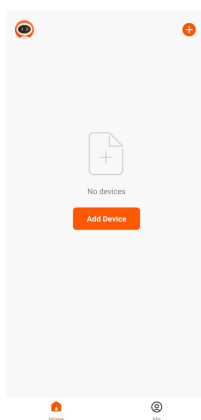

Step 1

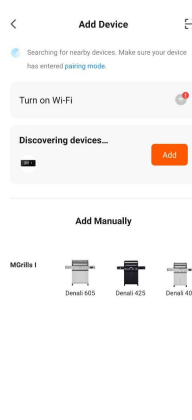

Step 2

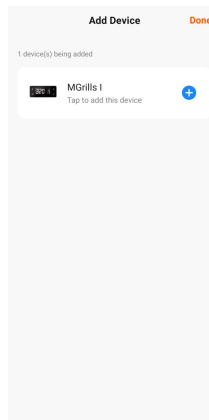

Step 3

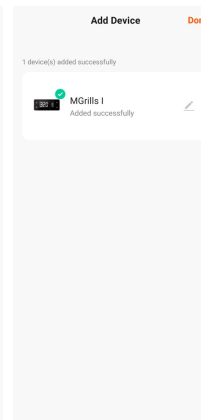

Step 4

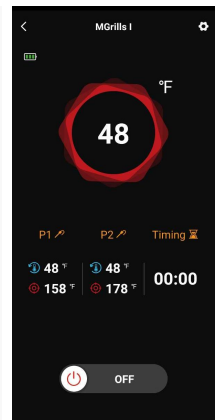

Step 5

Monument App Instructions

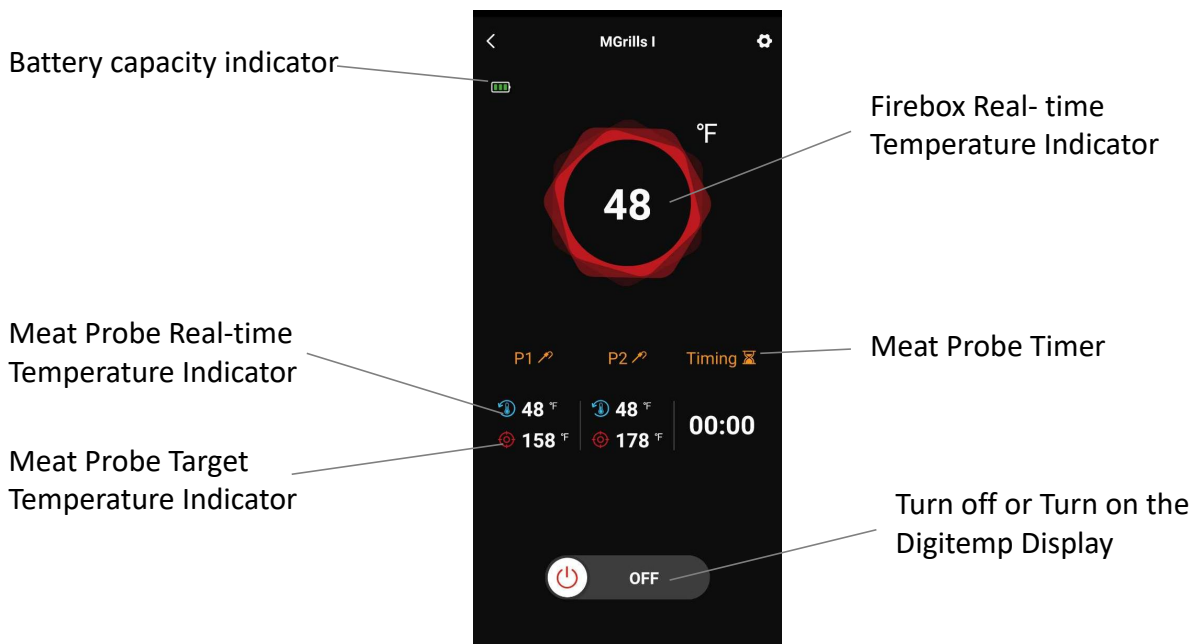

1. Firebox Temperature Indicator

You can monitor the real-time fire box temperature in Firebox Temperature Indicator. This temperature data is not adjustable by the APP or Digitemp Display.

2. Generate temperature curve

The APP will keep monitoring the firebox temperature and generate the temperature curve, click Firebox Temperature Indicator on the screen to view the temperature curve. You can back to previous page by clicking return icon "<" on the upleft corner.

3. Meat Probe Temperature Indicator

You can monitor the meat probe temperature and setup target temperature for two meat probes in Meat Probe Indicator. Click P1 or P2 indicator area to setup the target temperature or you can choose type of meat and select your preferred donness. There will be a beep from the phone to remind you when the target temperature is reached.

4. Battery Capacity Indicator

You can monitor the battery capacity indicator, while the battery icon is flashing without any bars in the frame, please replace the batteries with new.

Cleaning and Maintenance

To ensure a proper working unit the following proper care and maintenance is suggested.

Cleaning Cooking Grids

We suggest you wash your cooking grids in a mild soap and warm water solution. You can use a wash cloth or soft brush to clean your cooking grids.

Cleaning Heat Diffusers

Periodically you should wash the heat diffusers in a soap and warm water solution. Use a soft brush to remove stubborn burnt-on cooking residue. The heat diffusers should be dry before you reinstall them.

Cleaning Grease Tray

The grease tray should be emptied and wiped down periodically and washed in a mild detergent and warm water solution. A small amount of sand or cat litter may be placed in bottom of grease tray to absorb the grease. Check the grease tray frequently, don't allow excess grease to accumulate and overflow out of the grease tray.

Annual Cleaning of Grill Interior

Burning-off the grill after every use will keep it ready for your next use. However, once a year you should give the entire grill a thorough cleaning to keep it in top operating condition. Follow these steps.

1. Turn all burner valves to full OFF position.
2. Turn LP gas tank valve to full OFF position.
3. Detach LP gas hose and regulator assembly from your gas grill. Inspect for any damage and replace as necessary with manufacturer replacement part number found on parts list.
4. Remove and clean heat diffusers, cooking grids and grill burners.
5. Cover each gas valve orifice with aluminum foil.
6. Brush inside and bottom of grill with a nylon brush, and wash with a mild soap and warm water solution. Rinse thoroughly and let dry.
7. Remove the aluminum foil, then reinstall heat diffusers, and cooking grids.
8. Reconnect gas source and observe burner flame for correct operation.

Cleaning Exterior Surface

•We suggest you wash your grill using a mild soap and warm water solution. You can use a wash cloth or sponge for this process. Do not use abrasives or a brush that might remove finish during the cleaning process.

Cleaning Exterior Stainless Steel Surfaces

•Weathering and extreme heat can cause exterior stainless steel surfaces to turn tan in color. Machine oils used in manufacturing process of stainless steel can also cause this tanning color. Use a stainless steel cleaner to polish stainless steel surfaces of your grill. Never use abrasive cleaners or scrubbers because they will scratch and damage your grill.

Cleaning Burner Tubes and Burner Ports

To reduce the chance of "FLASH-BACK" the procedure below should be followed at least once a month in late summer or early fall when spiders are most active or when your grill has not been used for a period of time.

1. Turn all burner valves and gas tank valve to off position.
2. Detach the LP gas regulator assembly from your gas grill.
3. Remove cooking grids, heat diffusers, and grease tray from the grill.
4. Remove the screws from the underside of each burner and lift the burners up and away from the gas valve orifice.
5. Using a bent stiff wire in the shape of a hook, air hose or a bottle brush, run it through the burner tube and inside several times to remove any debris.
6. Replace burners, see illustration below.

Step 1

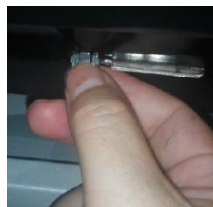

Step 2



Step 3



WARNING

The location of the burner tube with respect to the orifice is vital for safe operation. Check to ensure the orifice is inside the burner tube before using the gas grill. If the burner tube does not fit over the valve orifice, lighting the burner may cause explosion and/or fire.

Regardless of which burner cleaning procedure you use, we recommend you also complete the following steps to help prolong burner life.

1. Use a fiber pad or nylon brush to clean the entire outer surface of each burner until free of food residue and dirt.
2. Clean any clogged ports with a stiff wire, such as an open paper clip.

3. Inspect each burner for damage (cracks or holes) and if such damage is found, order and install a new burner. After installation check to ensure that gas valve orifices are correctly placed inside the ends of the burner tubes.

 **WARNING**

Spiders and insects can nest inside the burners of the grill and disrupt gas flow. This very dangerous condition could cause a fire behind the valve panel, thereby damaging the grill and making it unsafe for operation. Inspect the grill at least twice a year.

Troubleshooting

BEFORE CALLING FOR SERVICE

If the grill does not function properly, use the following check list before calling for service.

You should inspect the burners at least once a year or immediately after any of the following conditions occur:

PROBLEMS	WHAT TO DO
Grill won't light when the control knob is rotated.	<ul style="list-style-type: none"> ● Check to see if LP tank is empty. ● Clean wires and/or electrode by rubbing with alcohol and clean swab. ● Wipe with dry cloth. ● Make sure the wire is connected to electrode assembly. ● Check to see if other burners operate. If so, check the gas orifice on the malfunctioning burner for an obstruction.
Burner flame is yellow or orange, in combination with the odor of gas.	<ul style="list-style-type: none"> ● Refer to Clean Burner Tubes and Burner Ports on page 26. If problem still exists, please contact us.
Low heat with knob in "HI" position.	<ul style="list-style-type: none"> ● Is the fuel hose bent or kinked? ● Is the grill in a dusty area? ● Is there adequate gas supply available? ● If it is only one burner that appears low, does the orifice or burner need cleaning? ● Is the gas supply or gas pressure low?
Error Code "ERP"	<ul style="list-style-type: none"> ● Dis-connect the probe wire and connect again. ● If re-connect is not work, please contact our service center.

Model Denali 605 Parts Diagram

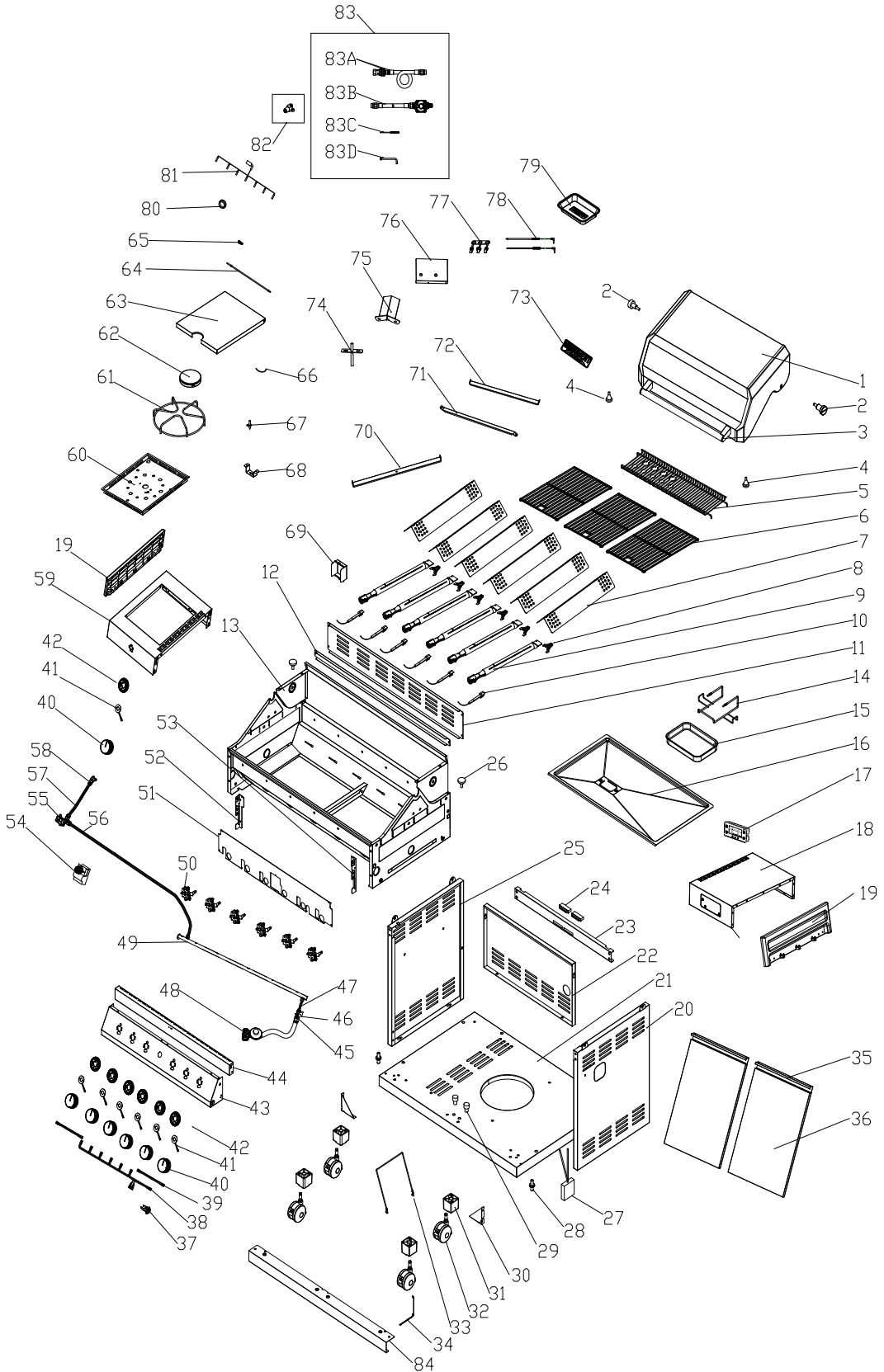

Model Denali 605 Parts List

seq. NO.	appellation	qty	Material code	seq. NO.	appellation	qty	Material code
1	Main Lid	1	D1100400188A	46	Valve Converter Bracket	1	D010012298
2	Main Lid Screw	2	A0407141	47	Corrugated Pipe	1	A0212829
3	Main Lid Handle	1	A02120572	48	Regulator	1	A0212831
4	Hood Buffer	2	A0201340	49	Gas Valve	1	A02120206
5	Warming Rack	1	A02122504	50	Main Gas Valve	6	A02120914
6	Cooking Grid With Hole	3	A02122455	51	Front Baffle	1	D010012052
7	Flame Tamer	6	D0100121112	52	Control Panel Fixing Panel, Left	1	D010012050
8	Clamp Spring	6	A0211012	53	Control Panel Fixing Panel, Right	1	D010012051
9	Main Burner	6	A02121327	54	Ignitor	1	A02120840
10	Main Burner Igniter Wire	6	A0212865	55	Side Burner Gas Valve	1	A02122630
11	Back Panel, Top	1	D010013984	56	Side Burner Bellows	1	A02120090
12	Back Panel, A	1	D30P000050	57	Side Burner Bellows	1	A020021
13	Fire Box	1	D30P000586	58	Side Burner Nozzel Seat	1	A0212828
14	Grease Box Bracket	1	A02120196	59	Side Burner Shelf Kit	1	D30H000321
15	Grease Box	1	D010024507	60	Side Burner Tray	1	D30M000815
16	Grease Tray	1	D010021003	61	Side Burner Cooking Grid	1	A02122176
17	Digitemp Display Kit	1	A02122428	62	Side Burner	1	A0212533
18	Side Shelf, Right	1	D30M001096	63	Side Burner Lid	1	D010007598
19	Side Shelf End Cap	2	A02121802	64	Side Burner Lid Hinge Rod	1	A0212534
20	Cabinet Side Panel,Right	1	D010012661	65	Side Burner Lid Spring	1	A0212617
21	Cart Bottom Shelf	1	D010026038	66	Side Burner Igniter Wire	1	A0212890
22	Back Panel, Bottom	1	D010026037	67	Side Burner Igniter	1	A0212436
23	Cart Frame, Front	1	D010015794	68	Side Burner Orifice Bracket	1	D019706920
24	Door Magnet	2	A0201249	69	Heat Insulation Box	1	D010014628
25	Cabinet Side Panel,Left	1	D010012660	70	Gas Cylinder Heat Shield,Post	1	D010022390
26	Hood Buffer	2	A0212666	71	Gas Cylinder Heat Shield,Above	1	D010022388
27	Battery Box	1	A02122561	72	Gas Cylinder Heat Shield,Middle	1	D010022389
28	Spindle Below Door Panel	2	A0212557	73	Logo	1	A0212808
29	Spacing Screw Below Door Panel	2	A02120079	74	Temperature Sensor	1	A02122305
30	Triangle Bracket	2	D010012746	75	Temperature Sensor Cover	1	A02122226
31	Swivel Caster Fixing Plug	4	A0212805	76	Display Screen Baffle	1	D30M001244
32	Swivel Caster	4	A0211004	77	Plug	1	A02122505
33	Gas-jar Fixing Line	1	A0212837	78	Meat Probe	2	A02121224
34	Lighting Rod	1	A02121323	79	Foil Tray	1	A02122520
35	Door Handle	2	D010015001	80	Rubber ring	1	A020064
36	Cabinet Door	2	D010012228	81	Ignition line	1	A02121311
37	LED Lamp Switch	1	A0212627	82	NG Side Burner Orifice	1	A02120889
38	LED Lamp Circuit	1	A0212840	83	NG Assembly	1	D010026109
39	Side Burner LED Lamp Circuit	1	A02120085		(Not Included & Sold Separately)		
40	Control Knob	7	A02122219	83A	NG Hose	1	A02120849
41	LED Knob Lamp Panel	7	A02122511	83B	NG Regulator	1	A02120848
42	Control Knob Base	7	A02121102	83C	Slot Screwdriver	1	A02120843
43	Main Control Panel	1	D30M001112	83D	Orifice Sockets	1	A02120844
44	Main Control Panel Frame	1	D010013593	84	Bottom board front cover	1	D010013610
45	Gas Connector	1	A0212830				

To make sure you obtain the correct replacement parts for your gas grill, please refer to the part numbers on this page.

Important: Keep this Owner's Manual for convenient reference and for part replacement.

Important: Use only parts listed above. When ordering parts, providing the following information:

1. Model #
2. Part Number (see PART# in chart)
3. Part Description
4. Quantity of parts needed

Cooking Instructions



WARNING

**Do not leave the grill unattended.
Your grill will get very hot.**

Never lean over the cooking area while using your grill. Do not touch cooking surfaces, grill housing, Grill Lid or any other grill parts while the grill is in operation, or until the grill has cooled down after use. Failure to comply with these instructions may result in serious bodily injury.

Burn-off

Before cooking on your gas grill for the first time, you will want to "burn off" the grill to eliminate any odor or foreign matter. Just ignite the burners, lower the Lid, and operate grill on the HIGH setting for 3 to 5 minutes.

Cooking Temperatures

High setting: Only use this setting for fast warm-up, searing steaks or chops and for burning food residue off the grill after cooking is complete.

Never use the HIGH setting for extended cooking.

Medium to Low Settings: Most recipes specify medium to low settings, including all smoking, rotisserie cooking and for cooking lean cuts such as fish.

NOTE: Temperature settings will vary with the temperature and the amount of wind outside your home.

Direct Cooking

The direct cooking method can be used with the supplied cooking grids and food placed directly over the lit grill Burners. **Direct cooking requires the grill lid to be up.** The method is ideal for searing and whenever you want meat, poultry or fish to have an open-flame barbecued taste. Deep frying and smoking are also best cooked in this manner because they require direct heat.



WARNING

Do not line the bottom of the grill housing with aluminum foil, sand or any substance that will restrict the flow of grease into the grease tray. Failure to comply with these instructions could result in a fire or explosion which could cause serious bodily injury, death, or property damage.

Indirect Cooking

To cook **indirectly**, the food should be placed on the left or right side of your grill with the burner lit on the opposite side. **Indirect cooking must be done with the Lid down.**

Flare-ups

The fats and juices dripping from grilled food can cause flare-ups. Since flare-ups impart a favorably, distinctive taste and color to food cooked over an open flame, they should be accepted up to a point. Nevertheless, uncontrolled flaring can result in a ruined meal.

Replacing the Battery

If the LED do not light, the battery should be replaced. Change the led battery.

1. Find the battery box, open the lid.
2. Put 4pcs "AA" size battery, the positive and negative pole of the battery should keep the same as the pole in box.
3. Close the lid.

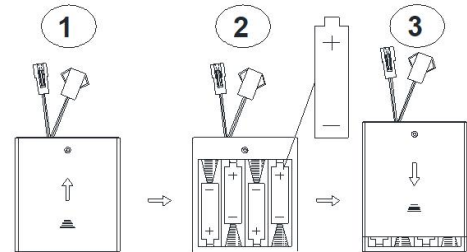

Correct Disposal of this product

This marking indicates that this product should not be disposed with other household wastes throughout the EU. To prevent possible harm to the environment or human health from uncontrolled waste disposal, recycle it responsibly to promote the sustainable reuse of material resources. To return your used device, please use the return and collection systems or contact the retailer where the product was purchased. They can take this product for environmental safe recycling.



Grill Cooking Chart

WARNING: To ensure that it is safe to eat, food must be cooked to the minimum internal temperatures listed in the table below.

USDA *Safe Minimum Internal Temperatures	
Fish	145°F
Pork	160°F
Egg Dishes	160°F
Steaks and Roasts of Beef, Veal or Lamb	145°F
Ground Beef, Veal or Lamb	160°F
Whole Poultry (Turkey, Chicken, Duck, etc.)	165°F
Ground or Pieces Poultry (Chicken Breast, etc.)	165°F

*United States Department of Agriculture

FOOD	Weight or thickness	Temperature	Time	Special instructions and tips
Vegetables	NA	Medium	8 to 20 minutes	Slice or chop vegetables and dot with butter or margarine. Wrap tightly in heavy duty foil. Grill turning occasionally.
Potatoes	Whole	Medium	40 to 60 minutes	Wrap individually in heavy duty foil. Cook rotating occasionally.
Meat/Steaks	1/2 to 3/4 inches	High-Medium	4 to 15 minutes	Pre heat grill for 15-20 minutes then sear steaks on each side for two minutes. Next grill 3 to 5 minutes on each side or until desired doneness.
Ground Meats	1/2 to 3/4 inches	Medium	8 to 15 minutes	Grill turning once when juices rise to the surface or until desired amount of doneness. Do not leave hamburgers unattended since a flare-up could occur quickly.
Ribs	1/2 or full rack	Medium	20 to 40 minutes	Grill turning occasionally. During last few minutes brush with barbecue sauce, turn several times.
Hot dogs	NA	Medium	5 to 10 minutes	Grill turning four times. 2-4 minutes on each of four sides.
Poultry-Cut	1/4 to 1/2 pounds	Low or Medium	20 to 40 minutes	Grill turning occasionally. During last few minutes brush with barbecue sauce if desired, turn several times.
Poultry Whole	2 to 3 pounds	Low or	1 to 1-1/2 hours	Use poultry stand and brush frequently as desired
		Medium	40 to 60 minutes	Use poultry stand and brush frequently as desired
Fish	3/4 to 1 inch	Medium	8 to 15 minutes	Grill turning once to desired doneness. Brush with melted butter, margarine or oil.

Natural Gas Conversion

Natural Gas Conversion Kit

(Not Included & Sold Separately)

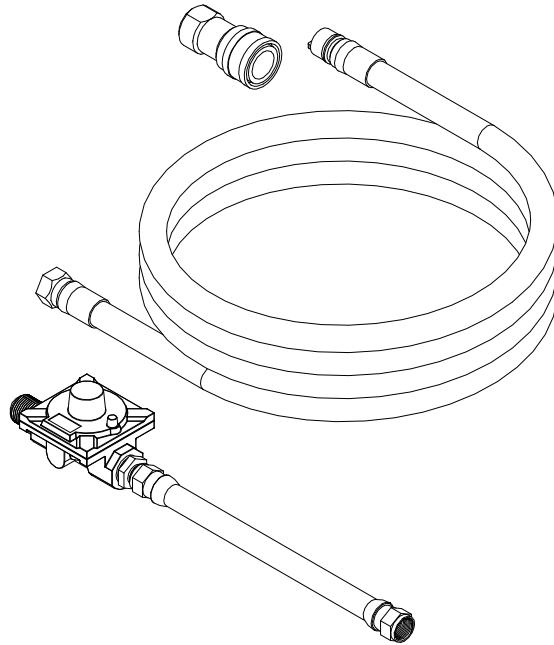

Warranty

One-Year Full Warranty on Part

If this part fails due to defective material or workmanship within one year from the date of purchase, please contact us to arrange for a free repair (or replacement if repair proves impossible)

Parts List

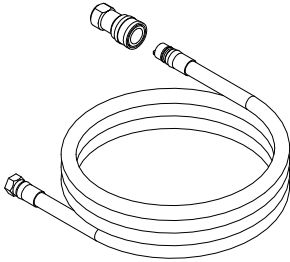

**NG Hose +Quick Connector
A02120849**

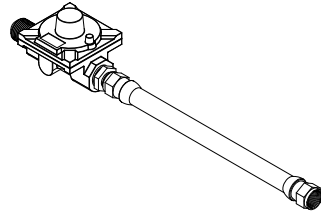

**NG Regulator
A02120848**

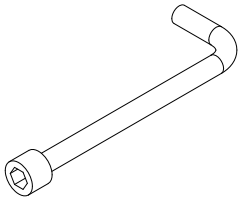

**6mm
Orifice Sockets
A02120844**

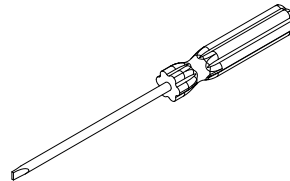

**Slot Screwdriver
A02120843**

Reminder:

Please keep the main burner brass LP orifices ,Side Burner Orifice and original LP regulator. Just in case you want to change back from Natural Gas(NG) to Liquid Propane(LP)

Natural Gas Conversion

WARNING! FAILURE TO READ THESE WARNINGS COULD RESULT IN A FIRE OR EXPLOSION THAT COULD CAUSE SERIOUS BODILY INJURY, DEATH OR PROPERTY DAMAGE.

Natural Gas Conversion must be performed by a **QUALIFIED GAS TECHNICIAN ONLY**. The **QUALIFIED GAS TECHNICIAN** should ensure compliance of local codes, including but not limited to, requirements and installation of grill regulator.

DO NOT ATTEMPT TO CONVERT YOURSELF. Improper conversion could result in a gas leak which could cause a fire or explosion and cause serious bodily injury, death or property damage. Leaks due to improper conversion could occur immediately or slowly over time. If you hear any unusual noises or leaks, smell gas or unusual odors, or notice anything unusual with the operation of your gas appliance after the installation immediately shut off the gas supply and discontinue use until the appliance is repaired by a **QUALIFIED GASTECHNICIAN**.

Below parts are needed for natural gas conversion:

INCLUDED

- § Natural gas orifices(Preinstalled In Grill)
- § Quick Connector
- § 10 ft (3.0m) Natural Gas Hose
- § 4" Water Column Regulator with Hose
- § Orifice Sockets
- § Slot screwdriver

NOT INCLUDED

- § House Supply Line
- § Wrench
- § Philips screwdriver

Tools will be needed for gas conversion

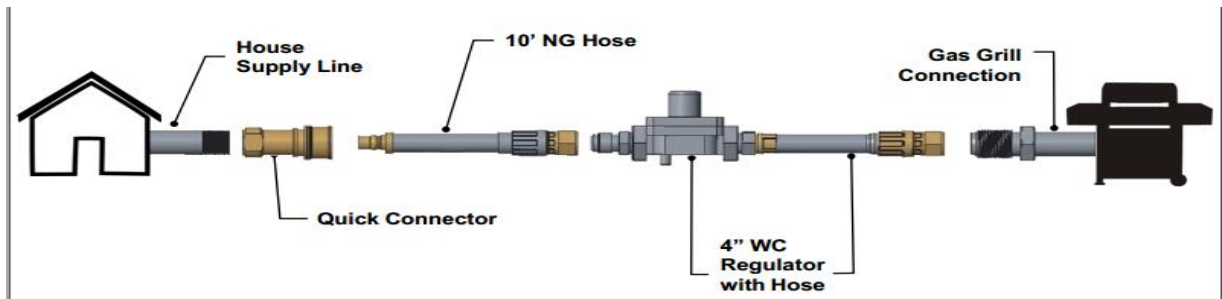
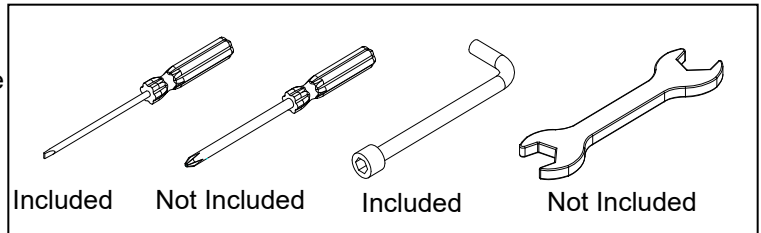

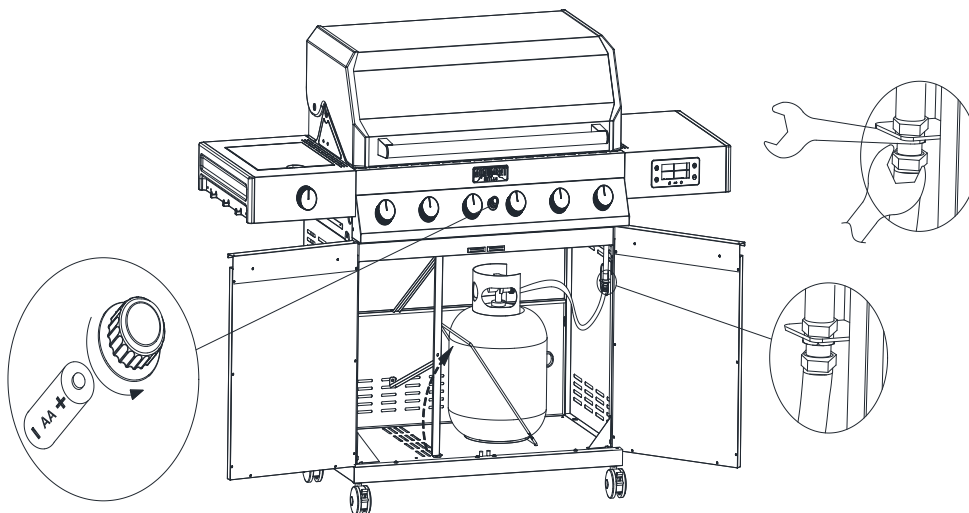

1. Turn off the main gas supply valve.
2. Disconnect LP gas fuel tank (if present).
3. Turn off all burner control valves.
4. Remove the LP gas fuel tank (if present) from the grill cart.
5. Use an adjustable wrench to remove the LP regulator from the manifold.

Reminder:

Please keep the original LP regulator.

Just in case you want to change back from NG to Propane.

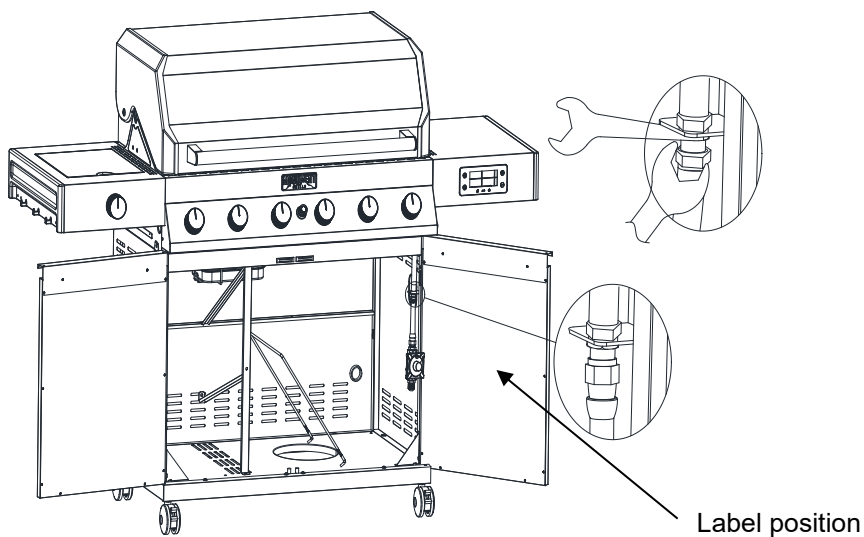

6. Use an adjustable wrench to install the Natural gas regulator hose to the manifold and secure

7. After LP is converted to NG, you need to put a label on the location shown below.

Make Gas Connection

1. Pass the NG hose to grill cart through the back panel

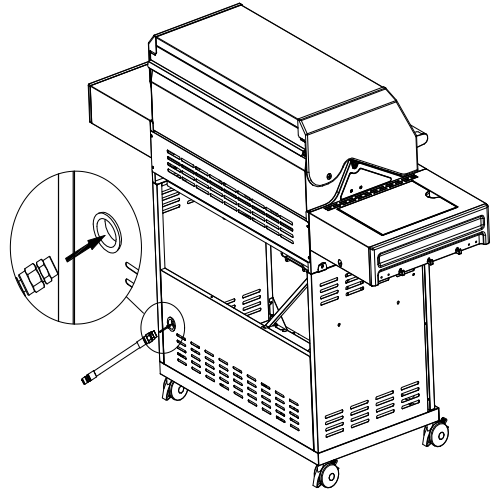

2. Connect the brass connector on one end of the 10 ft (3.0m) PVC flexible gas supply hose to the Natural gas pressure regulator

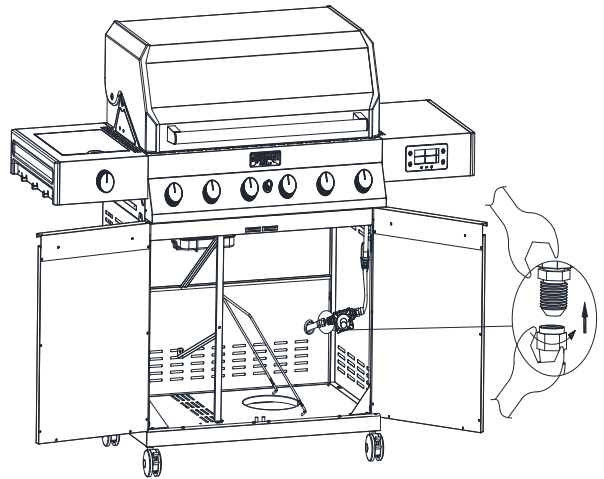

3. Connect the quick connector on the other end of the 10 ft (3.0 m) PVC flexible gas supply hose to the rigid Natural gas supply pipe.

4. Please do leak test after conversion

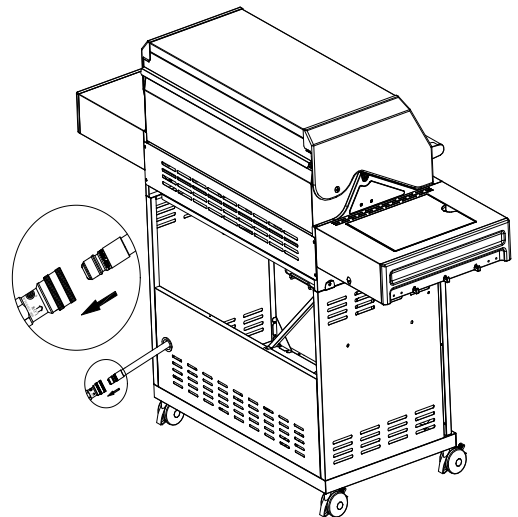

Change the Side Burner Orifice

The NG Side Burner Orifice is packed in grill with individual bag marked for NG gas conversion only.

Remove the LP Side Burner Orifice, and install the NG Side Burner Orifice

Reminder:

Please keep the LP Side Burner Orifice.

Just in case you want to change back from NG to Propane.

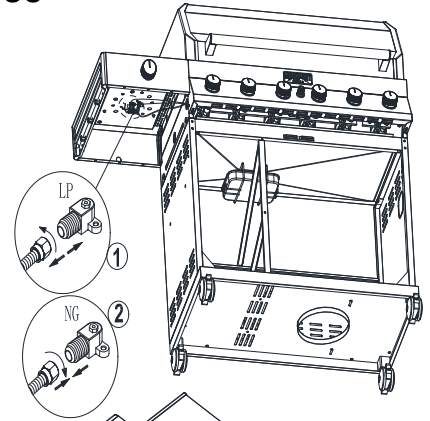

Adjust High/Low Flame Setting Screw

1: Remove all the control knobs

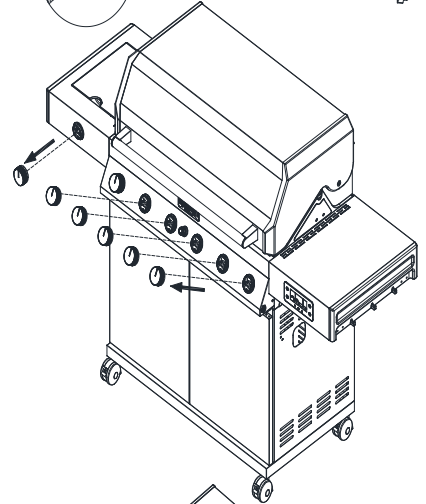

2: Use a flat-blade screwdriver to turn the high flame setscrew clockwise approximately 90°

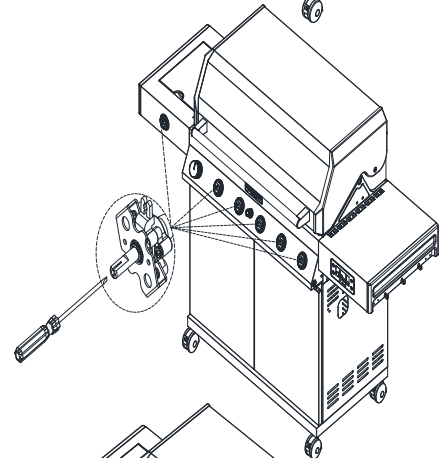

3: Check that burner operates at the new high flame setting. It may be necessary to adjust the screw setting slightly more to get the ideal burner flame height

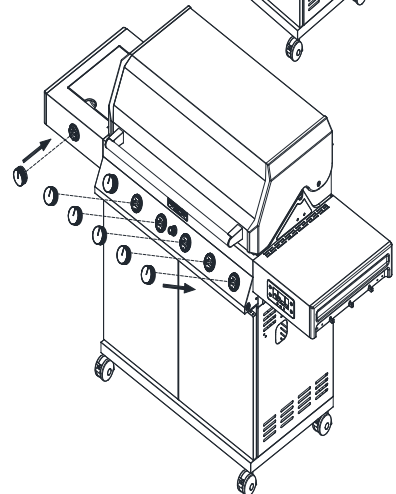

4: Replace the control knob and turn off the burner

Gas oven connection quick connector

1. Inspect the valve to ensure that the external mating threads are correct to fit the hose and regulator assembly provided.
 2. Make sure all burner valves are in the closed position.
 3. Check valve connection port and regulator assembly. Look for damage or debris. Remove all debris. Inspect the hose for damage. Never use damaged or blocked equipment.
 4. Remove the plug from the quick connector.
 5. Pull the snap ring back and plug in the connector.
 6. Loosen the quick snap ring and confirm whether the connection is secure.
 7. Open the natural gas valve fully (counterclockwise). Before attempting to ignite the grill, use a soapy water solution to check all connections for leaks. If a leak is found, close the valve and do not use the grille before repairing the leak.
- Note: When not using the product, the air supply valve must be closed.

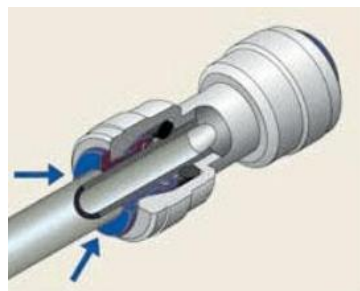

Gas oven disassembly quick connector

1. Make sure the gas pipeline valve is in the closed position.
2. Make sure all burner valves are in the closed position.
3. Pull the quick snap ring backwards and simultaneously pull the connected trachea backwards.
4. Use a plug to plug the port of the quick connector to prevent foreign objects from entering the air pipe.

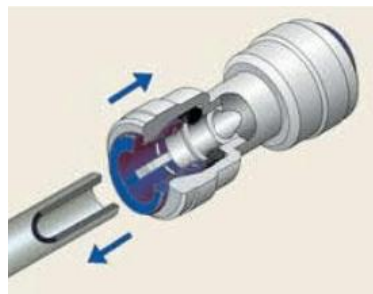

Check for gas leaks

Check the hose before using the outdoor cooking gas appliance. If there is a significant excessive wear or wear, or if the hose is cut, it must be replaced before the outdoor cooking gas appliance is put into operation. Replace the hose assembly as specified by the manufacturer.

1. Make a 50/50 (soap / water) mild soap solution.
2. open the door
3. Turn the control knob to the fully closed position; then open the valve of the natural gas pipeline.
4. Apply soap solution to all gas connections with a clean brush. as follows. If air bubbles appear in the solution, the connection is not properly sealed. Inspect each accessory and tighten or repair as needed.



5. If your gas connection leaks and you will not be able to repair it, turn off the gas in the gas supply tank, disconnect the fuel pipe from the grill, and call your gas supplier for repair assistance.

Congratulations

Your gas grill is now ready for use. Before first use and before the beginning of each season (and when the pressure regulator is replaced or installed):

1. Read all safety, lighting and operating instructions.
2. Check the gas valve hole, burner tube and burner port for obstructions.
3. Perform a gas leak check according to the instructions in the manual.

Burner Flame Check

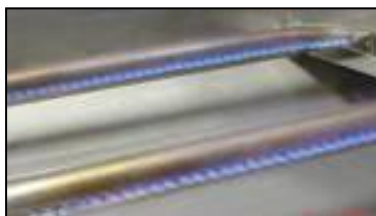

Visually check the burner flames prior to each use. The flames should look like picture, if they do not, refer to the cleaning burner tubes and ports, see page 26 of this manual.

Requiring the grill can be connected to the gas supply by means of a flexible hose connector complying with the current Standard for Elastomeric Composite Hose and Couplings for Conducting Propane and Natural Gas, CAN/CGA-8.1 or with the Standard for Thermoplastic Hose and Hose Couplings for Conducting Propane and Natural Gas, CAN1-8.3