

Warm Tips:

1. Module default output voltage and current is about 18V/7A, because the module is a step-down module, you need to adjust the output voltage lower than the input voltage, then it will work.
2. If you received the module and found that the output voltage cannot be adjusted, counter-clockwise adjust the CV voltage regulator potentiometer 20 laps or more, and then the module can adjust the voltage; the module is DC-DC buck module, cannot be used for AC.
3. Module default output is about 18V / 7A, if direct short-circuit the output terminal, adjust the current value, it will have great spark, which is dangerous, it is recommended to lower the output voltage below 10V, then counter-clockwise adjust CC current potentiometer more than 10 laps to the end, and then short-circuit the output terminal, adjust the CC potentiometer clockwise to slowly increase the current value you need.

Module Description:

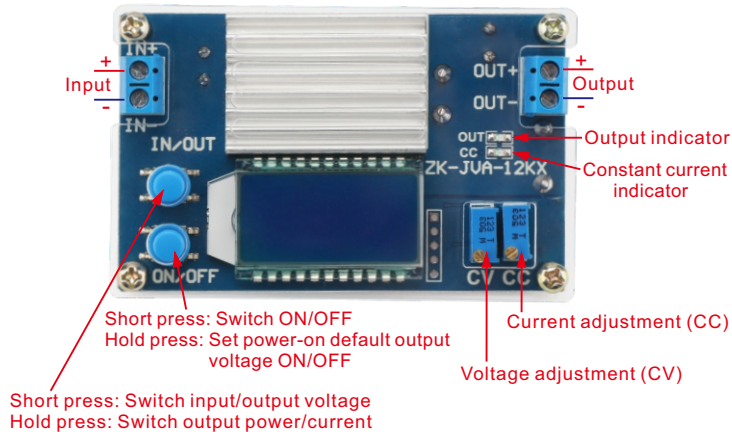

Parameters:

Input voltage range: DC 5.3-32V (limit 35V; the lowest input 4V can achieve buck, but less than 5.3V input voltage, current measurement is inaccurate)

Output voltage range: DC 1.2-32V (must ensure that the input voltage is higher than the output voltage, the minimum voltage difference is 0.8V)

Output current: 8A for long-term stable work, strengthen the heat dissipation can reach 12A

Output power: natural cooling 120W (within 8A), enhance cooling can reach 160W

Voltage display: resolution 0.05V, range 0-32V

Current display: resolution 0.01A, range 0-12A

Conversion efficiency: about 96%

Working current: 25mA or so

Soft start: Yes (high power with load module may fail to start)

Input reverse connection protection: yes

Output stop current from feeding back: none (if you charge the battery, first power the module then connect to the battery, and ensure that the battery voltage is lower than the output voltage)

Short circuit protection: yes

Dimension: 82x 52x 32mm

Function Description:

1. There are **IN/OUT**, **ON/OFF** two buttons on the module, **IN/OUT** button is to switch the input voltage and output voltage display, hold press to switch the output current and output power display; **ON/OFF** button control output ON or OFF, hold press set the power-on default output state is ON or OFF the next time.
2. CC is the current setting potentiometer, clockwise rotation can increase the set current, when the load current reaches the set current, enter the constant current state, CC constant current indicator (red) lights up; the right CV is the voltage setting potentiometer, clockwise rotation can increase the output voltage. OUT indicator is the output status indicator, when there is voltage output, it is on, otherwise it is off.

Input voltage/output current



Output voltage/output current



Input voltage/output power



Output voltage/output power

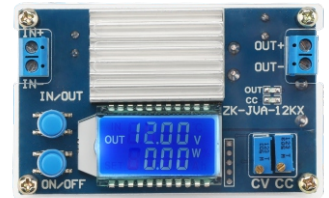

Default power-on output

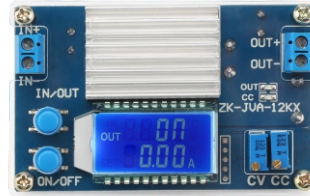

Default power-on no output



Application:

1. Used as an ordinary buck-boost module with over-current protection

- (1) Adjust the CV constant voltage potentiometer to adjust output voltage to reach the voltage you want.
- (2) Adjust CC potentiometer more than 10 laps counter-clockwise to the end, measure the output short circuit current with 10A or 20A multimeter (connect the two test leads directly to the output end), and adjust the CC constant current potentiometer clockwise to make the output current reaches the over-current protection value you want to set. (For example, if the current value displayed by the multimeter is 2A, the maximum current will only reach 2A when you use the module. When the current reaches 2A, the red constant current indicator is on, otherwise the indicator is off)

2. Used as a battery charger

Without constant current function of the module cannot be used to charge the battery, due to the power of the battery and the charger pressure drop is large, resulting in charging current is too large, which will cause damage to the battery, therefore, should use constant current charging the battery at the beginning, when charge to a certain extent automatically switch back to constant voltage charging.

- (1) Confirm the float voltage and charging current for the rechargeable battery you need (if the lithium battery parameter is 3.7V/2200mAh, then the float voltage is 4.2V and the maximum charging current is 1C, ie 2200mA).
 - (2) Under no-load condition, use multimeter to measure the output voltage and adjust the CV potentiometer to make the output voltage reaches the float voltage. (If charge the 3.7V lithium battery, adjust the output voltage to 4.2V).
 - (3) Adjust CC potentiometer more than 10 laps counter-clockwise to the end, measure the output short-circuit current with 10A or 20A multimeter (directly connect the two test leads to the output terminal), and adjust the CC potentiometer so that the output current reaches the preset charge current value.
 - (4) Connect the battery, charging.
- (Steps 1, 2 and 3 are as follows: input terminal connect to power supply, the output is not connected to the battery load)

3. As a high-power LED constant current drive module

- (1) Confirm the operating current and the maximum operating voltage of the LED you need to drive;
- (2) Under no-load condition, use the multimeter to measure the output voltage, and adjust the CV potentiometer to make the output voltage reach the maximum operating voltage of the LED;
- (3) Adjust CC potentiometer more than 10 laps counter-clockwise to the end, then use a 10A or 20A multimeter to measure the output short-circuit current, and adjust the CC potentiometer clockwise to make the output current reach the preset LED operating current;
- (4) Connect to the LED, test module.

(Steps 1, 2 and 3 are as follows: input terminal connect to power supply, the output is not connected to the battery, no load)

Attentions:

1. Module input IN- cannot short circuit with output OUT-, otherwise constant current function will be invalid.
2. Please make sure that the power of the power supply is greater than the power required by the output load. Please reduce the power when the module is extremely hot.

Package Including:

1x Step-down Converter