

Product Model 产品型号	MQ02	Brand 品牌	POWERQI	Product Type 产品类	User Manual	Description 描述	
Part Number 物料编号		Job No. 图档编码	(MQ02)	Membrane 表面工艺		Color 颜色	four color printing
Material 材质	128g black powder paper	Dimension 尺寸	90*65mm	Scale 比例	1:1	Tolerance 公差	
Revision 版本号		Original Designer 原设计师		Verifying 审核		Date 日期	2026.5.11
Remark 备注		Change Description 版本变更描述					

90.0 mm

Cooling Magnetic Wireless Car Charger
User Manual

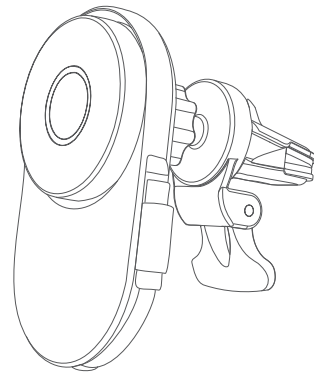

Thank you for purchasing this product!

This product is a cooling magnetic wireless car charger with built-in cable. It can serve as a vehicle-mounted mobile phone holder and extend the battery life of the phone, allowing you to enjoy the unlimited fun of digital products with ease.

Before using this product, please read this manual carefully and keep it properly for future reference.

List of Accessories

Wireless car charger x1

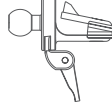
Air vent bracket x1



Nutsert x1

Car adapter x1

Specification

Input: 5V-3A, 9V-3A, 12V-2.92A, 15V-2.33A
Output: 25W MAX
Frequency: 115-205kHz, 360kHz
Charging distance: <=3mm
Conversion: >=70%
Size: 66x43x115mm
N.W.: 120g

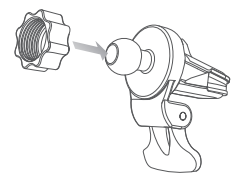
Installation steps



① Remove the fixing nutsert and insert the outlet bracket into place.

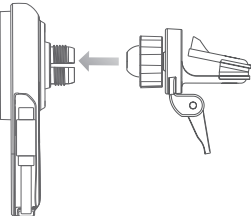

② Push the ball head into the circular hole at the back of the vehicle-mounted bracket. Tighten the screw cap clockwise to secure it properly. Then, you can adjust the vehicle-mounted wireless charger to the desired angle.

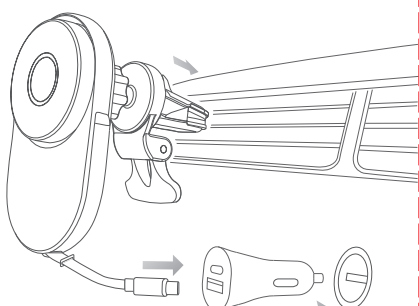

③ Insert the nozzle clamp of the vehicle-mounted wireless charger into the car nozzle clamp piece to the appropriate position, and then move the fixing lever to fix the wireless charger onto the car nozzle clamp piece.

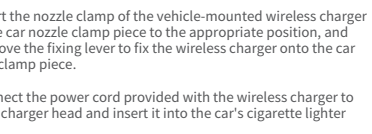

④ Connect the power cord provided with the wireless charger to the car charger head and insert it into the car's cigarette lighter socket.

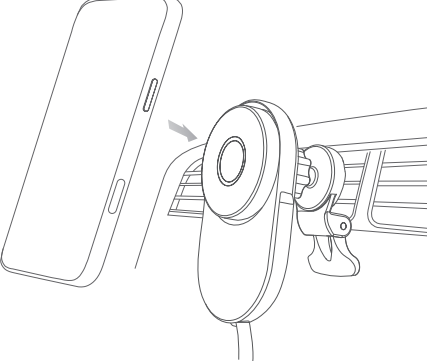

⑤ Place the mobile phone with magnetic wireless charging function on the in-car wireless charger. The charging plate will automatically align and start charging simultaneously.

* This product also supports charging wireless charging devices that do not have magnetic suction function.

FCC Warning

This device complies with part 15 of the FCC Rules. Operation is subject to the following two conditions: (1) This device may not cause harmful interference, and (2) this device must accept any interference received, including interference that may cause undesired operation.

Any changes or modifications not expressly approved by the party responsible for compliance could void the user's authority to operate the equipment.

NOTE: This equipment has been tested and found to comply with the limits for a Class B digital device, pursuant to Part 15 of the FCC Rules. These limits are designed to provide reasonable protection against harmful interference in a residential installation. This equipment generates, uses and can radiate radio frequency energy and, if not installed and used in accordance with the instructions, may cause harmful interference to radio communications. However, there is no guarantee that interference will not occur in a particular installation.

If this equipment does cause harmful interference to radio or television reception, which can be determined by turning the equipment off and on, the user is encouraged to try to correct the interference by one or more of the following measures:

- Reorient or relocate the receiving antenna.
- Increase the separation between the equipment and receiver.
- Connect the equipment into an outlet on a circuit different from that to which the receiver is connected.
- Consult the dealer or an experienced radio/TV technician for help.

FCC Radiation Exposure Statement

This equipment complies with FCC radiation exposure limits set forth for an uncontrolled environment. This equipment should be installed and operated with a minimum distance of 20 cm between the radiator and your body.

Notes

- Do not squeeze or collisions.
- Do not disassemble or throw into fire or water, to avoid causing a short circuit leakage.
- Do not use wireless charger in severely hot, humid or corrosive environments, to avoid circuit damage and occurs leakage phenomenon.
- Do not place too close with magnetic stripe or chip card (ID card, bank cards, etc.) to avoid magnetic failure.
- Please keep the distance at least 20cm between implantable medical devices (pacemakers, implantable cochlear, etc.) and the wireless chargers, to avoid potential interference with the medical device.
- To take care of the children, to ensure that they won't play the wireless charger as a toy, to avoid unnecessary accidents.

* All the pictures involved in the manual are schematic diagrams. The final product shall be subject to the actual item.
Included: wireless charger, air vent bracket, nutsert, car adapter, user manual.

65.0 mm

90.0 mm

风冷车载磁吸无线充电器
用户手册

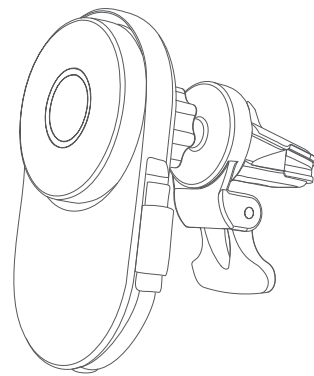

感谢您购买本产品!

本产品是一款风冷自带线车载手机无线充电器,可充当车载手机支架并延长手机的续航时间,让您轻松体验数码产品的无限乐趣。

使用本产品前请认真阅读本手册并妥善保存,以备查阅。

配件清单

车载无线充电器 x1

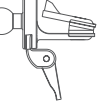
出风口支架 x1



固定螺母 x1

车充头 x1

规格参数

输入: 5V-3A, 9V-3A, 12V-2.92A, 15V-2.33A
输出: 25W MAX
工作频率: 115-205kHz, 360kHz
接收距离: <=3mm
电力转换: >=70%
规格尺寸: 66x43x115mm
产品重量: 120g

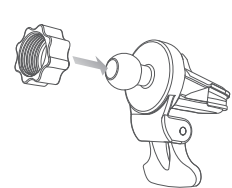
安装步骤



① 取下固定螺母,将出风口支架套入。

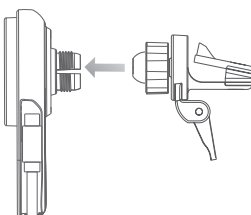

② 将球头推进车载支架背面圆孔处,顺时针拧紧螺母固定好后,可调整车载无线充电器到合适的角度。

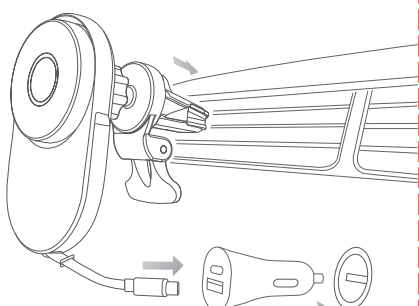

③ 将车载无线充电器的出风口夹头插入汽车出风口夹片到合适的位置,拨动固定杠杆,将无线充电器固定在汽车出风口夹片上。

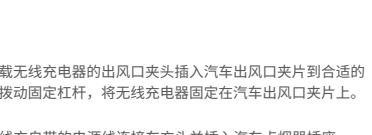

④ 将无线自带的电源线连接车充头并插入汽车点烟器插座。

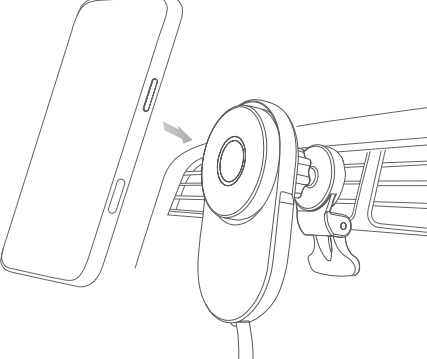

⑤ 将带有磁吸无线充电功能的手机放置在车载无线充电器上,充电板会自动吸附到位置同时开始充电。

* 本产品同时支持不带磁吸功能的无线充电设备进行充电。

FCC警告

本设备符合FCC规则第15部分。操作受以下两个条件的约束:

- 本设备不得造成有害干扰;
- 本设备必须接受接收到的任何干扰,包括可能导致意外操作的干扰。

任何未经过责任方明确批准的更改或修改都可能导致用户操作设备的权力失效。

注意: 根据FCC规则第15部分,本设备已经过测试,发现符合B类数字设备的限制。这些限制旨在提供合理的保护,防止住宅安装中的有害干扰。本设备产生、使用并可辐射射频能量,如果未按照说明安装和使用,可能会对无线电通信造成有害干扰。但是不能保证在特定安装中不会发生干扰。

如果本设备确实对无线电或电视接收造成有害干扰,这可以通过关闭和打开设备来确定,鼓励用户尝试通过以下一个或多个措施来纠正干扰:

- 重新定向或重新定位接收天线。
- 增加设备和接收器之间的分离。
- 将设备连接到与接收器连接的电路不同的电路上的出口。
- 咨询经销商或经验丰富的广播/电视技术人员寻求帮助。

FCC辐射暴露声明

该设备符合针对不受控制环境规定的FCC辐射暴露限值。本设备应在散热器和您的身体之间的最小距离为20cm的情况下安装和操作。

注意事项

- 请勿挤压或碰撞。
- 请勿自行拆卸或投入火中、水中,避免造成短路漏电。
- 请勿在严重高温、潮湿或腐蚀性环境下使用无线充电器,避免损坏电路出现漏电现象。
- 请勿与带磁条或者芯片的磁卡(身份证、银行卡等)放置太近,避免造成磁卡失效。
- 请保持植入医疗设备(心脏起搏器、植入性耳蜗等)与无线充电器之间的距离至少为20cm,以避免对医疗设备造成潜在干扰。
- 应看管好儿童,以确保他们不将无线充电器当成玩具来玩,以避免不必要的意外。

* 说明书涉及图片均为示意图,最终产品以实物为准。
内容: 无线充电器、出风口支架、螺母、车充头、用户手册。