

Save This Manual
For Future Reference

Sears

*owners
manual*

**MODEL NO.
113.290600**

SAW WITH
MOTOR ONLY

113.290650

SAW WITH MOTOR,
LEGS AND
TWO TABLE EXTENSIONS

Serial
Number _____

Model and serial
numbers may be found
at the left-hand side
of the base.

You should record both
model and serial number
in a safe place for future
use.

CAUTION:

Read **GENERAL**
and **ADDITIONAL**
SAFETY
INSTRUCTIONS
carefully

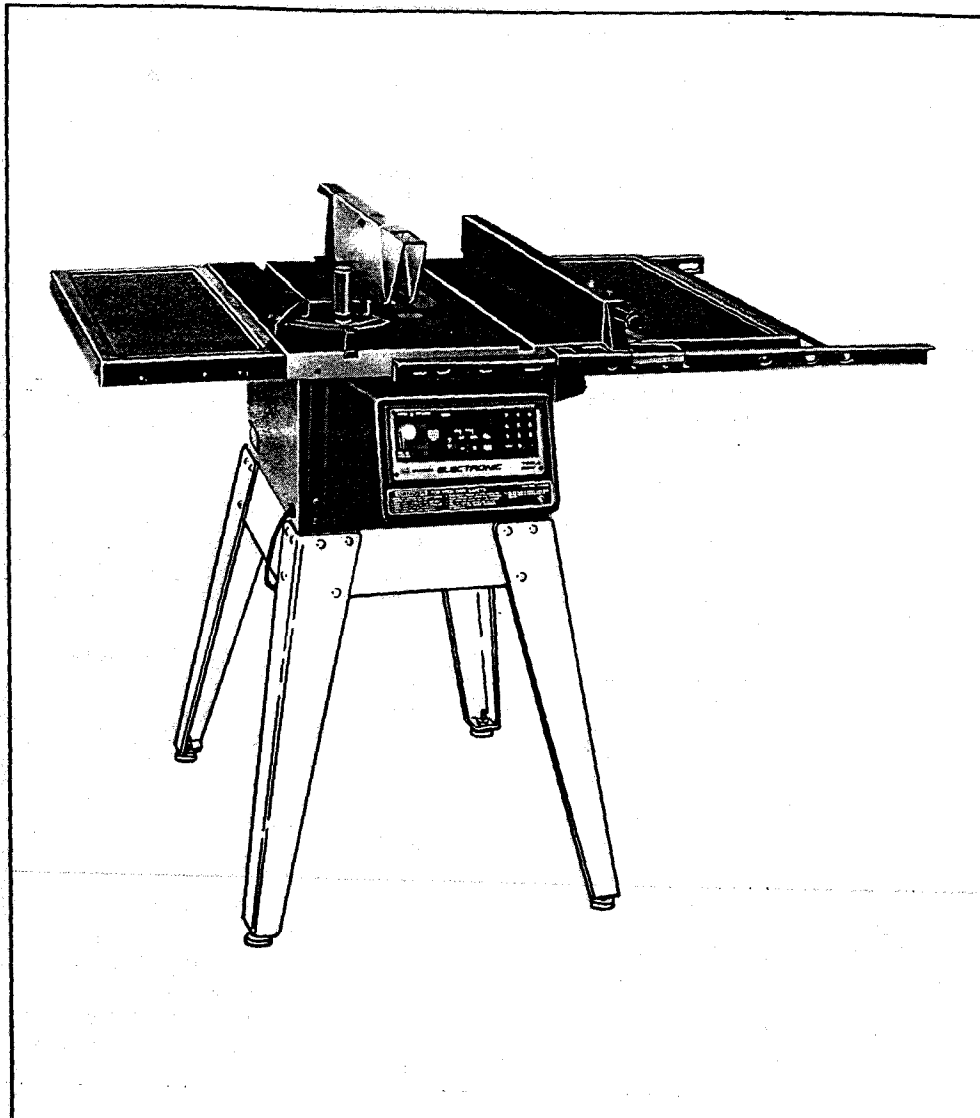

Sears

CRAFTSMAN

**ELECTRONIC
10-INCH TABLE SAW**

- *assembly*
- *operating*
- *repair parts*

Sold by SEARS, ROEBUCK AND CO., Chicago, IL. 60684 U.S.A.

FULL ONE YEAR WARRANTY ON CRAFTSMAN TABLE SAW

If within one year from the date of purchase, this Craftsman Table Saw falls due to a defect in material or workmanship, Sears will repair it, free of charge.

WARRANTY SERVICE IS AVAILABLE BY SIMPLY CONTACTING THE NEAREST SEARS SERVICE CENTER/DEPARTMENT THROUGHOUT THE UNITED STATES.

This warranty applies only while this product is used in the United States.

This warranty gives you specific legal rights, and you may also have other rights which vary from state to state.

SEARS, ROEBUCK AND CO., DEPT. 698/731A Sears Tower, Chicago, IL 60684

GENERAL SAFETY INSTRUCTIONS FOR POWER TOOLS

- 1. KNOW YOUR POWER TOOL**
Read and understand the owner's manual and labels affixed to the tool. Learn its application and limitations as well as the specific potential hazards peculiar to this tool.
- 2. GROUND ALL TOOLS**
This tool is equipped with an approved 3-conductor cord and a 3-prong grounding type plug to fit the proper grounding type receptacle. The green conductor in the cord is the grounding wire. Never connect the green wire to a live terminal.
- 3. KEEP GUARDS IN PLACE,**
in working order, and in proper adjustment and alignment.
- 4. REMOVE ADJUSTING KEYS AND WRENCHES**
Form habit of checking to see that keys and adjusting wrenches are removed from tool before turning it on.
- 5. KEEP WORK AREA CLEAN**
Cluttered areas and benches invite accidents. Floor must not be slippery due to wax or sawdust.
- 6. AVOID DANGEROUS ENVIRONMENT**
Don't use power tools in damp or wet locations or expose them to rain. Keep work area well lighted. Provide adequate surrounding work space.
- 7. KEEP CHILDREN AWAY**
All visitors should be kept a safe distance from work area.
- 8. MAKE WORKSHOP KID-PROOF**
— with padlocks, master switches, or by removing starter keys.
- 9. DON'T FORCE TOOL**
It will do the job better and safer at the rate for which it was designed.
- 10. USE RIGHT TOOL**
Don't force tool or attachment to do a job it was not designed for.
- 11. WEAR PROPER APPAREL**
Do not wear loose clothing, gloves, neckties or jewelry (rings, wrist watches) to get caught in moving parts. Non-slip footwear is recommended. Wear protective hair covering to contain long hair. Roll long sleeves above the elbow.
- 12. USE SAFETY GOGGLES (Head Protection)**
Wear Safety goggles (must comply with ANSI Z87.1) at all times. Everyday eyeglasses only have impact resistant lenses, they are NOT safety glasses. Also, use face or dust mask if cutting operation is dusty, and ear protectors (plugs or muffs) during extended periods of operation.
- 13. SECURE WORK**
Use clamps or a vise to hold work when practical. It's safer than using your hand, frees both hands to operate tool.
- 14. DON'T OVERREACH**
Keep proper footing and balance at all times.
- 15. MAINTAIN TOOLS WITH CARE**
Keep tools sharp and clean for best and safest performances. Follow instructions for lubricating and changing accessories.
- 16. DISCONNECT TOOLS**
before servicing; when changing accessories such as blades, bits, cutters, etc.
- 17. AVOID ACCIDENTAL STARTING**
Make sure switch is in "OFF" position before plugging in.
- 18. USE RECOMMENDED ACCESSORIES**
Consult the owner's manual for recommended accessories. Follow the instructions that accompany the accessories. The use of improper accessories may cause hazards.
- 19. NEVER STAND ON TOOL**
Serious injury could occur if the tool is tipped or if the cutting tool is accidentally contacted.
Do not store materials above or near the tool such that it is necessary to stand on the tool to reach them.
- 20. CHECK DAMAGED PARTS**
Before further use of the tool, a guard or other part that is damaged should be carefully checked to ensure that it will operate properly and perform its intended function. Check for alignment of moving parts, binding of moving parts, breakage of parts, mounting, and any other conditions that may affect its operation. A guard or other part that is damaged should be properly repaired or replaced.
- 21. DIRECTION OF FEED**
Feed work into a blade or cutter against the direction of rotation of the blade or cutter only.
- 22. NEVER LEAVE TOOL RUNNING UNATTENDED**
Turn power off. Don't leave tool until it comes to a complete stop.

ADDITIONAL SAFETY INSTRUCTIONS FOR TABLE SAWS

WARNING: FOR YOUR OWN SAFETY, DO NOT OPERATE YOUR SAW UNTIL IT IS COMPLETELY ASSEMBLED AND INSTALLED ACCORDING TO THE INSTRUCTIONS . . . AND UNTIL YOU HAVE READ AND UNDERSTAND THE FOLLOWING:

1. **GENERAL SAFETY INSTRUCTIONS FOR POWER TOOLS . . . SEE PAGE 2**
2. **GETTING TO KNOW YOUR SAW . . . SEE PAGE 22**
3. **BASIC SAW OPERATION SEE PAGE 27**
4. **MAINTENANCE SEE PAGE 41**
5. **STABILITY OF SAW**

If there is any tendency for the saw to tip over or move during certain cutting operations such as cutting extremely large heavy panels or long heavy boards, the saw should be bolted down. If you attach any kind of table extensions over 24" wide to either end of the saw, make sure you either bolt the saw to the bench or floor as appropriate, or support the outer end of the extension from the bench or floor, as appropriate.

6. LOCATION

The saw should be positioned so neither the operator nor a casual observer is forced to stand in line with the saw blade.

7. KICKBACKS

A "KICKBACK" occurs during a rip-type operation when a part or all of the workpiece is thrown back violently toward the operator.

Keep your face and body to one side of the sawblade, out of line with a possible "Kickback."

Kickbacks — and possible injury from them — can usually be avoided by:

- A. Maintaining the rip fence parallel to the sawblade.
- B. Keeping the sawblade sharp. Replace or sharpen antikickback pawls when points become dull.
- C. Keeping sawblade guard, spreader, and antikickback pawls in place and operating properly. The spreader must be in alignment with the sawblade and the pawls must stop a kickback once it has started. Check their action before ripping.
- D. NOT ripping work that is twisted or warped or does not have a straight edge to guide along the rip fence.
- E. NOT releasing work until you have pushed it all the way past the sawblade.
- F. Using a push stick for ripping widths of 2 to 6 in., and an auxiliary fence and push block for ripping widths narrower than 2 in. (See "Basic Saw Operation Using The Rip Fence" section.)
- G. NOT confining the cut-off piece when ripping or cross-cutting.

8. PROTECTION: EYES, HANDS, FACE, EARS, BODY

A. If any part of your saw is missing, malfunctioning, or has been damaged or broken . . . such as the motor switch, electronic controls, or other operating control, a safety device or the power cord . . . cease operating immediately until the particular part is properly repaired or replaced.

- B. Wear safety goggles that comply with ANSI Z87.1, and a face shield or dust mask if operation is dusty. Wear ear plugs or muffs during extended periods of operation.
- C. Small loose pieces of wood or other objects that contact the rear of the revolving blade can be thrown back at the operator at excessive speed. This can usually be avoided by keeping the guard and spreader in place for all thru-sawing operations (sawing entirely thru the work) AND by removing all loose pieces from the table with a long stick of wood IMMEDIATELY after they are cut off.
- D. Use extra caution when the guard assembly is removed for resawing, dadoing, rabbeting, or molding — replace the guard as soon as that operation is completed.
- E. For rip or rip-type cuts, the following end of a workpiece to which a push stick or push board is applied must be square (perpendicular to the fence) in order that feed pressure applied to the workpiece by the push stick or block does not cause the workpiece to come away from the fence, and possibly cause a kickback.
- F. During rip and rip type cuts, the workpiece must be held down on the table and against the fence with a push stick, push block, and featherboards, as required. A featherboard is made of solid lumber (at least 3/4" thick) per sketch.

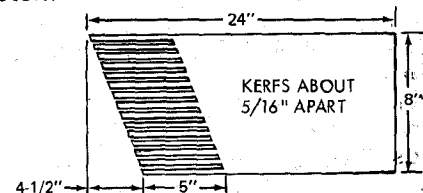

- G. NEVER turn the saw "ON" before clearing the table of all tools, wood scraps, etc., except the workpiece and related feed or support devices for the operation planned.
- H. NEVER place your face or body in line with the cutting tool.
- I. NEVER place your fingers or hands in the path of the sawblade or other cutting tool.
- J. NEVER reach in back of the cutting tool with either hand to hold down, or support the workpiece, remove wood scraps, or for any other reason. Avoid awkward operations and hand positions where a sudden slip could cause fingers or hand to move into a sawblade or other cutting tool.
- K. DO NOT perform layout, assembly, or setup work on the table while the cutting tool is rotating.
- L. DO NOT perform any operation "FREEHAND" — always use either the rip fence or the miter gauge to position and guide the work.
- M. NEVER use the rip fence when crosscutting or the miter gauge when ripping. DO NOT use the rip fence as a length stop. Never hold onto or touch the "free end" of the workpiece or a "free piece" that is cut off, while power is "ON" and/or the sawblade is rotating.

N. Shut "OFF" the saw and disconnect the power cord when removing the table insert, changing the cutting tool, removing or replacing the blade guard, or making adjustments.

O. Provide adequate support to the rear and sides of the saw table for wider or long workpieces.

P. Plastic and composition (like hardboard) materials may be cut on your saw. However, since these are usually quite hard and slippery, the antikickback pawls may not stop a kickback.

Therefore, be especially attentive to following proper set-up and cutting procedures for ripping. Do not stand, or permit anyone else to stand, in line with a potential kickback.

Q. If you stall or jam the sawblade in the workpiece turn saw "OFF" and remove the workpiece from the sawblade. Check to see if the sawblade is parallel to the miter gauge grooves and if the spreader is in proper alignment with the sawblade. If ripping at the time, check to see if the rip fence is parallel with the sawblade. Readjust as indicated.

R. DO NOT remove small pieces of cut-off material that may become trapped inside the blade guard while the saw is running. This could endanger your hands or cause a kickback. Turn saw "OFF" and wait until blade stops.

S. Use extra care when ripping wood that has a twisted grain or is twisted or bowed — it may rock on the table and/or pinch the sawblade.

9. KNOW YOUR CUTTING TOOLS

A. Dull, gummy, or improperly sharpened or set cutting tools can cause material to stick, jam, stall the saw, or kickback at the operator.

Minimize potential injury by proper cutting tool and machine maintenance.

NEVER ATTEMPT TO FREE A STALLED SAWBLADE WITHOUT FIRST TURNING THE SAW OFF.

B. Never use grinding wheels, abrasive cut-off wheels, friction wheels (metal slitting blades) wire wheels or buffing wheels.

10. USE ONLY ACCESSORIES DESIGNED FOR THIS SAW

11. Crosscutting operations are worked more conveniently and with greater safety if an auxiliary wood facing is attached to the miter gauge using the holes provided. However, the facing must not interfere with the proper functioning of the sawblade guard.

12. Make sure the top of the arbor or cutting tool rotates toward you when standing in normal operating position. Also make sure the cutting tool, arbor collars and arbor nut are installed properly. Keep the cutting tool as low as possible for the operation being performed. Keep all guards in place whenever possible.

13. Do not use any blade or other cutting tool marked for an operating speed less than 3450 RPM. Never use a cutting tool larger in diameter than the diameter for which the saw was

designed. For greatest safety and efficiency when ripping, use the maximum diameter blade for which the saw is designed, since under these conditions the spreader is nearest the blade.

14. Adjust table inserts flush with the table top. NEVER operate the saw unless the proper insert is installed.

15. NEVER feed material into the cutting tool from the rear of the saw. An accident and serious injury could result.

16. THINK SAFETY.

Safety is a combination of operator common sense and alertness at all times when the saw is being used.

17. NEVER use another person as a substitute for a table extension, or as additional support for a workpiece that is longer or wider than the basic saw table, or to assist in feeding or supporting or pulling the workpiece.

DO NOT pull the workpiece through the sawblade - position your body at the nose (in-feed) side of the guard: start and complete the cut from that same side. This will require added table support for long or wide workpieces that extend beyond the length or width of the saw table.

18. NOTE AND FOLLOW SAFETY INSTRUCTIONS THAT APPEAR ON THE FRONT OF YOUR SAW.

⚠ DANGER FOR YOUR OWN SAFETY:			120V, 60HZ, 14.5AMPS
1. READ AND UNDERSTAND OWNER'S MANUAL BEFORE OPERATING MACHINE.	6. NEVER REACH AROUND OR OVER SAWBLADE.	10. DO NOT PLUG IN POWER CORD UNTIL MOTOR CORD IS CONNECTED TO MOTOR.	
2. WEAR SAFETY GOGGLES PER ANSI Z87.1.	7. NEVER PERFORM ANY OPERATION "FREEHAND".	9. USE SAWBLADE GUARD FOR "THRU-SAWING".	
3. KEEP HANDS OUT OF PATH OF SAWBLADE.	8. USE SAWBLADE GUARD FOR "THRU-SAWING".	9. SHUT OFF MASTER SWITCH AND ALLOW SAWBLADE TO STOP BEFORE ADJUSTING OR SERVICING.	
4. KNOW HOW TO AVOID "KICKBACKS".	9. SHUT OFF MASTER SWITCH AND ALLOW SAWBLADE TO STOP BEFORE ADJUSTING OR SERVICING.		
5. USE "PUSH STICK" WHEN REQUIRED.			

19. **WARNING: DO NOT ALLOW FAMILIARITY (GAINED FROM FREQUENT USE OF YOUR SAW) TO BECOME COMMONPLACE. ALWAYS REMEMBER THAT A CARELESS FRACTION OF A SECOND IS SUFFICIENT TO INFLICT SEVERE INJURY.**

20. **WARNING: THE 2-1/2" SAW PULLEY AND THE 2-1/2" MOTOR PULLEY FURNISHED, WILL RUN THE BLADE AT APPROXIMATELY 3450 RPM WHEN USED WITH A 3450 RPM MOTOR. NEVER SUBSTITUTE THESE PULLEYS TO INCREASE THIS SPEED BECAUSE IT COULD BE DANGEROUS.**

NOTE: Do not overtighten arbor nut. Use the arbor wrench to just "snug" it.



The operation of any power tool can result in foreign objects being thrown into the eyes, which can result in severe eye damage. Always wear safety goggles complying with ANSI Z87.1 (shown on Package) before commencing power tool operation. Safety Goggles are available at Sears retail or catalog stores.

WARNING: DO NOT UNDER ANY CIRCUMSTANCES ATTEMPT TO SERVICE, REPAIR, DISMANTLE, OR DISASSEMBLE ANY OF THE ELECTRICAL OR ELECTRONIC (COMPUTER ETC.) PARTS. REPAIRS ARE TO BE PERFORMED BY SEARS SERVICE PERSONNEL ONLY.

MOTOR SPECIFICATIONS AND ELECTRICAL REQUIREMENTS

This saw is designed to use a 3450 RPM motor only. Do not use any motor that runs faster than 3450 RPM. It is wired for operation on 110-120 volts, 60 Hz., alternating current. **IT MUST NOT BE CONVERTED TO OPERATE ON 230 VOLTS.**

CONNECTING TO POWER SOURCE OUTLET

This saw must be grounded while in use to protect the operator from electrical shock.

If power cord is worn or cut, or damaged in any way, have it replaced immediately.

Your saw has a plug that looks like the one below.

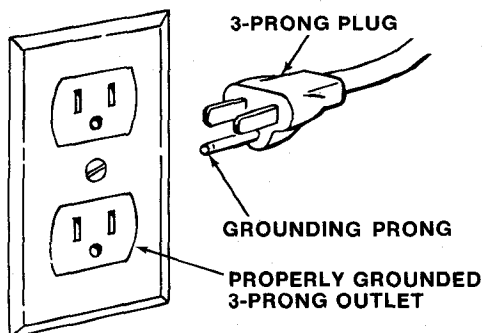

Plug power cord into 110-120V properly grounded type outlet protected by a 15-amp. time delay or Circuit-Saver fuse or circuit breaker.

IF YOU ARE NOT SURE THAT YOUR OUTLET IS PROPERLY GROUNDED, HAVE IT CHECKED BY A QUALIFIED ELECTRICIAN.

WARNING: DO NOT PERMIT FINGERS TO TOUCH THE TERMINALS OF PLUG WHEN INSTALLING OR REMOVING THE PLUG TO OR FROM THE OUTLET.

WARNING: IF NOT PROPERLY GROUNDED THIS POWER TOOL CAN HAVE THE POTENTIAL HAZARD OF ELECTRICAL SHOCK, PARTICULARLY WHEN USED IN DAMP LOCATIONS, AROUND PLUMBING, OR OUT OF DOORS. IF AN ELECTRICAL SHOCK OCCURS THERE IS THE POTENTIAL OF A SECONDARY HAZARD SUCH AS YOUR HANDS CONTACTING THE SAWBLADE.

This saw is equipped with a 3-conductor cord and grounding type plug which has a grounding prong, approved by Underwriter's Laboratories and the Canadian Standards Association. The ground

conductor has a green lug and is attached to the tool housing at one end and to the ground prong in the attachment plug at the other end.

This plug requires a mating 3-conductor grounded type outlet as shown.

If the outlet you are planning to use for this saw is of the two prong type **DO NOT REMOVE OR ALTER THE GROUNDING PRONG IN ANY MANNER.** Use an adapter as shown and always connect the grounding lug to a known ground.

It is recommended that you have a qualified electrician replace the TWO prong outlet with a properly grounded THREE prong outlet.

An adapter as shown below is available for connecting plugs to 2-prong receptacles. The green grounding lug extended from the adapter must be connected to a permanent ground such as to a properly grounded outlet box.

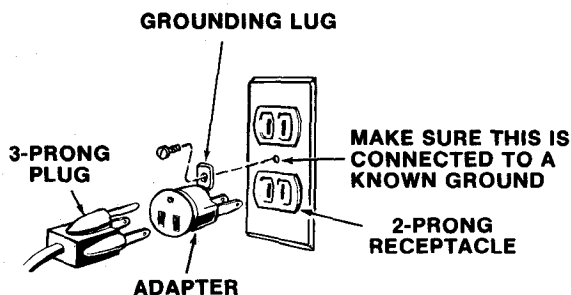

NOTE: The adapter illustrated is for use only if you already have a properly grounded 2-prong receptacle.

The use of any extension cord will cause some loss of power. To keep this to a minimum and to prevent over-heating and motor burn-out, use the table below to determine the minimum wire size (A.W.G.) extension cord. Use only 3 wire extension cords which have 3 prong grounding type plugs and 3-pole receptacles which will accept the plug on the saw.

1 H.P. MOTOR 110-120V

Extension Cord Length	Wire Size A.W.G.
Up to 50 Ft.	14
50 to 100 Ft.	12
100 - 200 Ft.	10
200 - 400 Ft.	8

CONTENTS

Warranty	2
General Safety Instructions	
For Power Tools	2
Additional Safety Instructions	
For Table Saw	3
Motor Specifications And	
Electrical Requirements	5
Unpacking And Checking Contents	6
Assembly	8
Getting To Know Your Saw	22
Location And Function of	
Electronic Controls	22

Location And Function of	
Mechanical Controls	23
Basic Saw Operation	27
Calibrating The Saw For	
Electronic Operations	29
Recommended Accessories	40
Maintenance	41
Lubrication	41
Trouble Shooting	42
Repair Parts	46

UNPACKING AND CHECKING CONTENTS

TOOLS NEEDED

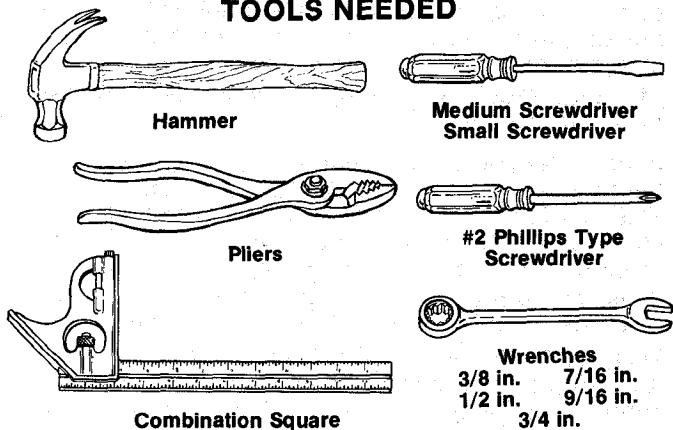

COMBINATION SQUARE MUST BE TRUE.

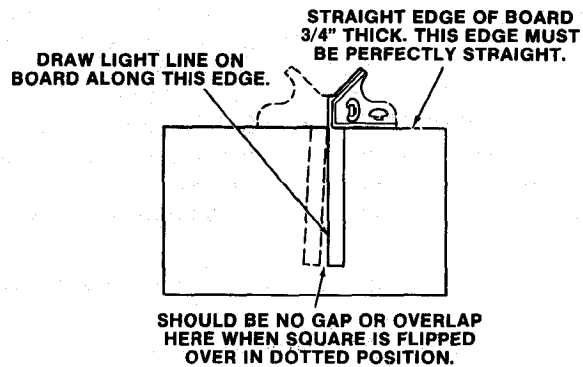

MODEL 113.290600
SUPPLIED LOOSE IN CARTON

Model 113.290600 Table Saw is shipped complete in one carton with motor but DOES NOT INCLUDE Table Extensions or Steel Legs.

Model 113.290650 Table Saw is shipped complete in one carton and INCLUDES Motor, Two Table Extensions and Steel Legs.

Separate all parts from packing materials and check each one with the illustration and the list of Loose Parts to make certain all items are accounted for before discarding any packing material.

If any parts are missing, do not attempt to assemble the table saw, plug in the power cord or turn the switch on until the missing parts are obtained and are installed correctly.

Remove the protective oil that is applied to the table top and edges of the table. Use any ordinary household type grease and spot remover.

CAUTION: Never use gasoline, naphtha or similar highly volatile solvents.

Apply a coat of automobile wax to the table.

Wipe all parts thoroughly with a clean, dry cloth.

WARNING: FOR YOUR OWN SAFETY, NEVER CONNECT PLUG TO POWER SOURCE OUTLET UNTIL ALL ASSEMBLY STEPS ARE COMPLETE, AND YOU READ AND UNDERSTAND THE SAFETY AND OPERATIONAL INSTRUCTIONS.

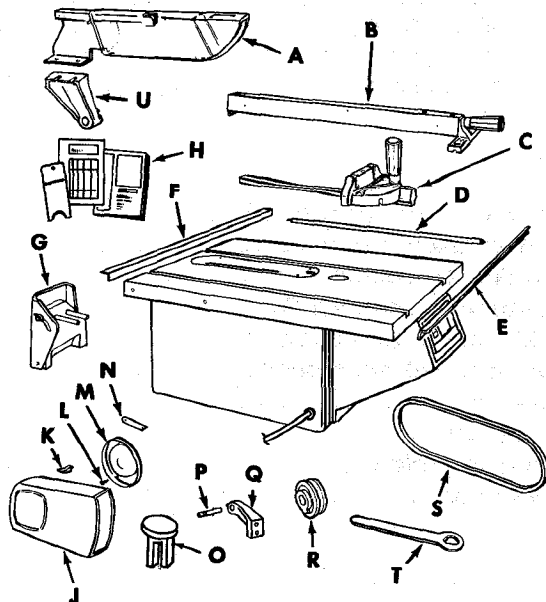

Item	Part Name	Qty.
A	Blade Guard and Spreader	1
B	Rip Fence	1
C	Miter Gauge	1
D	Rip Fence Guide Bar Rod	1
E	Rip Fence Guide Bar with Rip Scale (Front)	1
F	Rip Fence Guide Bar (Rear)	1
G	Motor Base	1
H	Bag Containing	1
	Owner's Manual	1
	Calibration Gauge	1
	Owner's Information Card	1
J	Guard, Belt	1
K	Clip, "S"	3
L	Screw, Pan Hd. Type "T" 10-32 x 1/2	3
M	Support, Belt Guard	1
N	Bracket Support	1
	Loose Parts Bag No. 62844 (Containing the Following Items):	
O	Key, Switch	1
	Loose Parts Bag No. 62836	1
	Loose Parts Bag No. 62836 (Containing the Following Items):	
P	Rod Assembly, Spreader	1
Q	Support, Spreader	1
R	Pulley	1
S	Belt, "V" 1/2 x 41	1
T	Wrench, Arbor	1
U	Support, Guard	1
	Loose Parts Bag No. 62835	1

MODEL 113.290600 and 113.290650

Item	Part Name	Qty.
	Loose Parts Bag. No 62835 (Containing the Following Items):	
V	Bolt, Carriage 5/16-18 x 3/4	4
W	Nut, Hex 5/16-18	8
W	Nut, Hex 1/4-20	2
X	Lockwasher, External 5/16	10
X	Lockwasher, External 1/4	2
Y	Screw, Hex Hd. 5/16-18 x 5/8	3
Y	Screw, Hex Hd. 5/16-18 x 1	4
Y	Screw, Hex Hd. 5/16-18 x 1-3/4	2
Y	Screw, Hex Hd. 1/4-20 x 5/8	2

Z	Spacer, Fence Guide Bar	2
AA	Nut, Self Threading	2
BB	Screw, Thumb 5/16-18 x 1	1
CC	Wrench, Hex L 1/8	1
CC	Wrench, Hex L 3/32	1
CC	Wrench, Hex L 5/32	1
DD	Key, Square 3/16	1

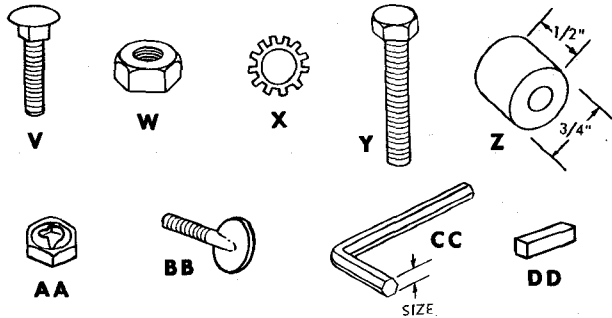

**MODEL 113.290650
SUPPLIED LOOSE IN CARTON**

Item	Part Name	Qty.
A	Blade Guard and Spreader	1
B	Rip Fence	1
C	Miter Gauge	1
D	Rip Fence Guide Bar Rod	1
E	Rip Fence Guide Bar with Rip Scale (Front)	1
F	Rip Fence Guide Bar (Rear)	1
G	Motor Base	1
H	Bag Containing Owner's Manual Calibration Gauge Owner's Information Card	1 1 1 1
J	Leg	4
K	Stiffener, Side	2
L	Stiffener, End	2
M	Extension, 10 x 27	2
N	Motor	1
O	Guard, Belt	1
P	Clip, "S"	3
Q	Screw, Pan Hd. Type "T" 10-32 x 1/2	3
R	Support, Belt Guard	1
S	Bracket, Support	1
Loose Parts Bag No. 62834 (Containing the Following Items):		
T	Switch Key	1
Loose Parts Bag No. 62836		
Loose Parts Bag No. 62752		
Loose Parts Bag No. 62745		
Loose Parts Bag No. 62836 (Containing the Following Items):		
U	Rod Assembly, Spreader	1
V	Support, Guard	1
W	Belt, Vee 1/2 x 41	1
X	Pulley	1
Y	Wrench, Arbor	1
Z	Support, Spreader	1
Loose Parts Bag No. 62835		

MODEL 113.290650

Item	Part Name	Qty.
Loose Parts Bag No. 62745		
(Containing the Following Items):		
AA	Bracket, Corner Support	2

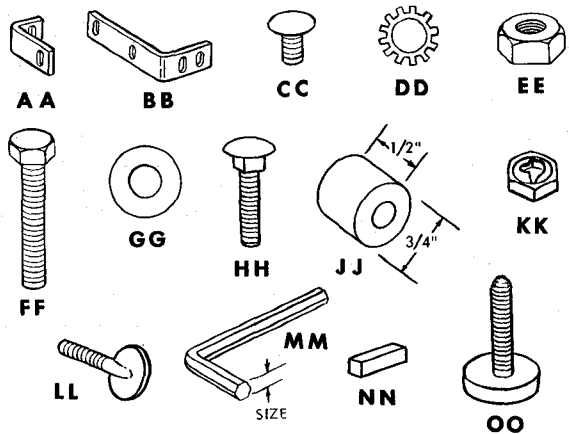
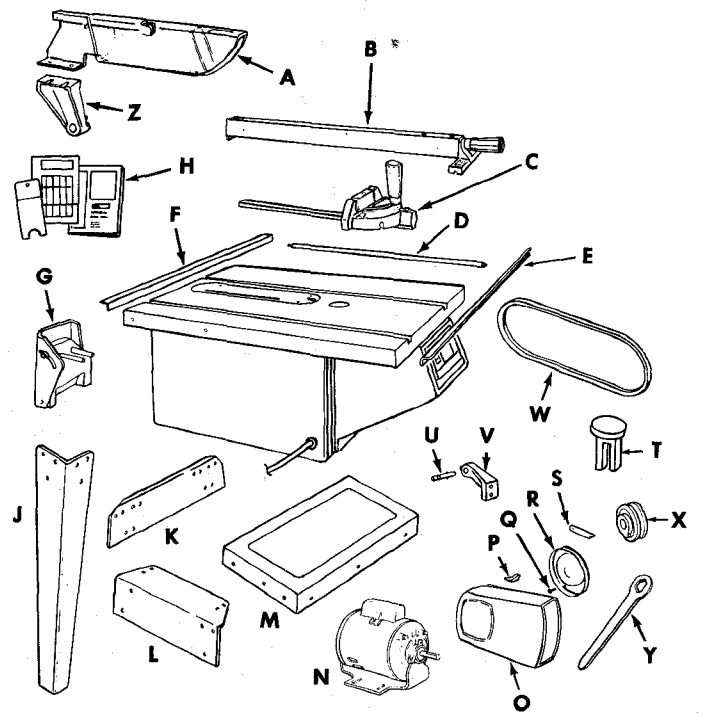

BB	Bracket, Corner Stiffener	2
Loose Parts Bag No. 62837		

**Loose Parts Bag No. 62837
(Containing the Following Items):**

CC	Screw, Truss Hd. 1/4-20 x 1	8
DD	Lockwasher, External 1/4	8
DD	Lockwasher, External 5/16	4
EE	Nut, Hex 1/4-20	8
FF	Nut, Hex 5/16-18	4
FF	Screw, Hex Hd. 5/16-18 x 1-1/4	4
GG	Washer, 11/32 x 11/16 x 1/16	4
GG	Washer, 17/64 x 3/4 x 1/16	2

**Loose Parts Bag No. 62835
(Containing the Following Items):**

DD	Lockwasher, External 5/16	10
DD	Lockwasher, External 1/4	2
EE	Nut, Hex 5/16-18	8
EE	Nut, Hex 1/4-20	2
FF	Screw, Hex Hd. 5/16-18 x 5/8	3
FF	Screw, Hex Hd. 5/16-18 x 1	4
FF	Screw, Hex Hd. 5/16-18 x 1-3/4	2
FF	Screw, Hex Hd. 1/4-20 x 5/8	2

HH Bolt, Carriage 5/16-18 x 3/4	4
JJ Spacer, Fence Guide Bar	2
KK Nut, Self Threading	2
LL Screw, Thumb 5/16-18 x 1	1
MM Wrench, Hex "L" 1/8	1
MM Wrench, Hex "L" 3/32	1
MM Wrench, Hex "L" 5/32	1
NN Key, Square 3/16	1

Loose Parts Bag No. 62752 for Legs	
(Containing the Following Items):	
CC Screw, Truss Hd. 1/4-20 x 5/8	24
DD Lockwasher, External 1/4	24
DD Lockwasher, External 5/16	4
EE Nut, Hex 1/2-13	8
EE Nut, Hex 1/4-20	24
EE Nut, Hex 5/16-18	4
FF Screw, Hex 5/16-18 x 1-1/4	4
GG Washer, 11/32 x 11/16 x 1/16	8
00 Foot, Leveling	4

ASSEMBLY

ASSEMBLING STEEL LEGS

NOTE: Steel Legs are furnished with Model 113.290650.

From among the loose parts, find the following Hardware:

- 24 Truss Head Screws, 1/4-20 x 5/8 in. long (top of screw is rounded)
- 24 Lockwashers, 1/4 in. External Type (approx. dia. of hole 1/4 in.)
- 24 Hex nuts, 1/4-20 (approx. dia. of hole 1/4 in.)
- 8 Hex Nuts, 1/2-13 (approx. dia. of hole 1/2 in.)
- 4 Leveling feet.

Assemble the legs as shown . . .

1. Insert the Truss Head Screws through the holes in the legs, then through the holes in the stiffeners. **MAKE SURE THE SCREWS GO THROUGH THE HOLES IN THE SIDE STIFFENERS MARKED "X"**.
2. Install the lockwashers . . . screw on the nuts but do not tighten until completely assembled.
3. Install leveling feet.

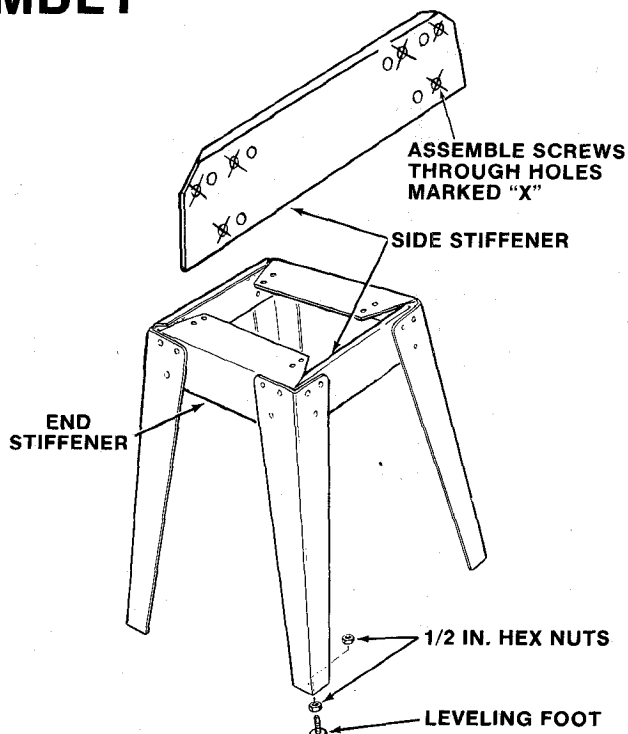

MOUNTING SAW

1. From among the loose parts, find the following hardware:
 - 4 Hex Head Screws, 5/16-18 x 1-1/4 in. long.
 - 4 Hex Nuts, 5/16-18 (approx. dia. of hole 5/16 in.)
 - 4 Lockwashers, 5/16 in. External Type (approx. dia. of hole, 5/16 in.)
 - 8 Flat Washers, (dia. of hole 11/32 in.)

NOTE: Do not lift saw by plastic housing.

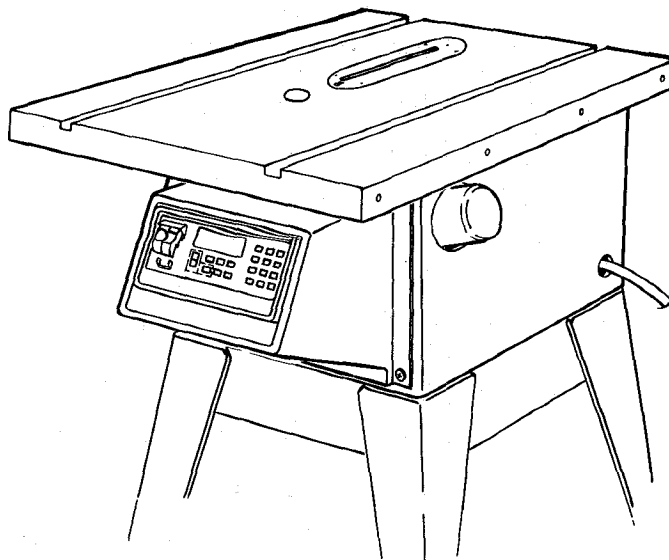

2. Place saw on legs so that holes in bottom of saw line up with holes in top of legs.
3. Install screws, washers, lockwashers and nuts as shown.

If you mount the saw on any other bench, make sure that there is an opening in the top of the bench the same size as the opening in the bottom of the saw so that the sawdust can drop through. Recommended working height is 33 to 37 inches from the top of the saw table to the floor.

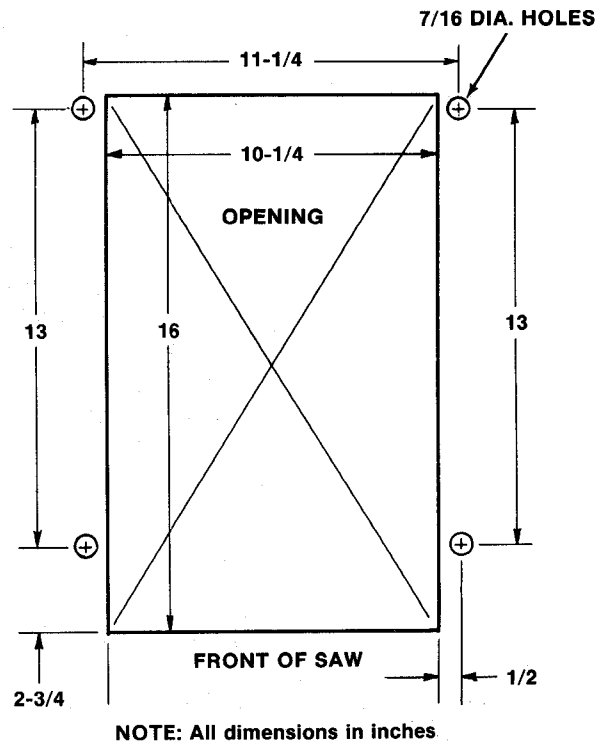
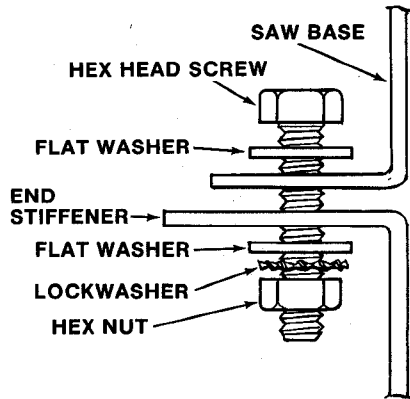

CHECKING TABLE INSERT

1. Insert should be flush with table top along its entire length. Check as shown. Loosen flat head screw that holds insert and adjust the four set screws as necessary. Tighten flat head screw. Do not tighten screw to the point where it deflects the insert.

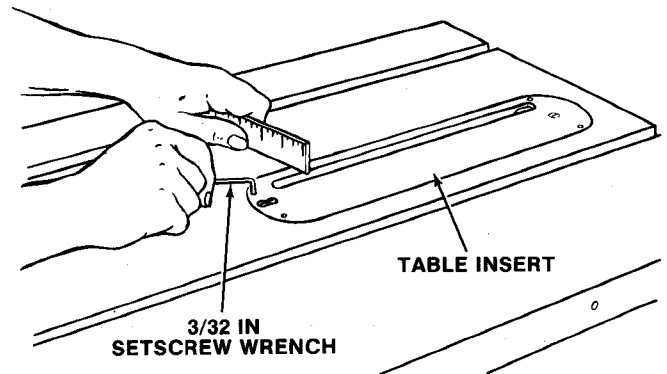

2. To remove insert.
 - A) Loosen Screw
 - B) Lift insert from end, and pull toward front of saw.
3. To replace insert.
 - Place insert into insert opening in table and push toward rear of saw to engage spring clip and until keyslot in insert will drop over screw. Tighten screw.
 - Do not tighten screw to the point where it will deflect the insert.

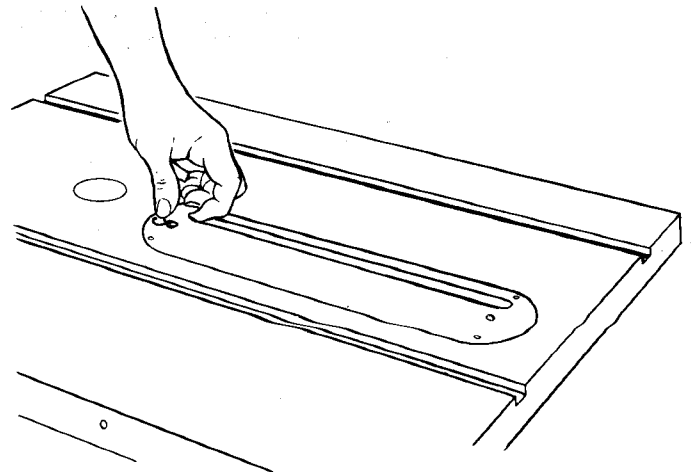

MOUNTING THE MOTOR

- From among the loose parts, find the following hardware:
 - 2 Hex Head Screws 5/16-18 x 5/8 in. long
 - 4 Carriage Bolts, 5/16-18 x 3/4 in. long
 - 4 Hex Nuts, 5/16-18 (approx. dia. of hole 5/16 in.)
 - 4 Lockwashers, 5/16 in. External Type (approx. dia. of hole 5/16 in.)
- Place motor on MOTOR BASE . . . insert bolts through holes in base . . . then through the motor. Install lockwashers, and nuts.
- Position motor so that edge of MOTOR FOOT and MOTOR BASE are even . . . slide motor all the way to the RIGHT . . . tighten the four nuts.

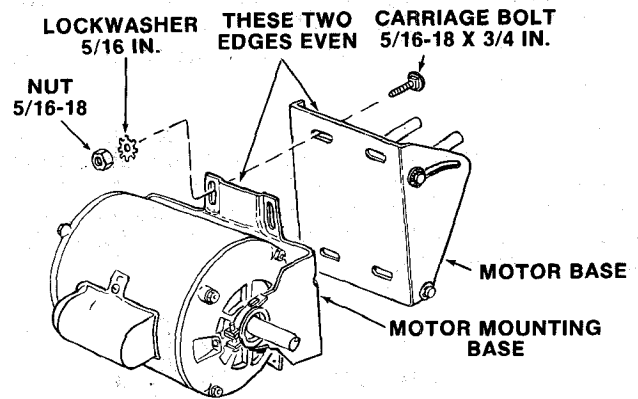

- Screw the two 5/16-18 x 5/8 in. motor base clamp screws part way into tapped holes in cradle.
- Lift motor and insert the TWO PINS on motor base into HOLES in cradle . . . push motor in as far as it will go.
- Tighten the two motor base clamp screws.

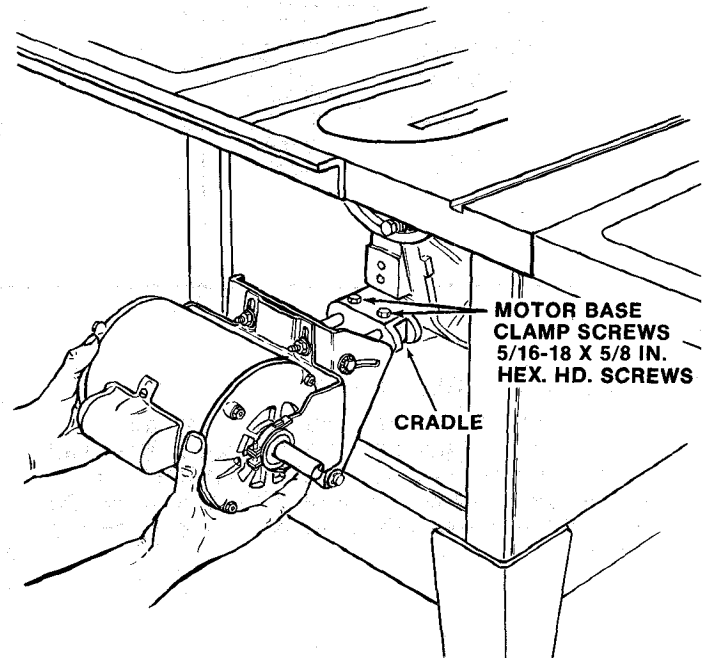

- Loosen the two MOTOR CLAMP SCREWS on each end of motor. Rotate the motor so that the CAPACITOR COVER is on top . . . tighten the screws. The ventilation holes are now facing downward which will help prevent sawdust from entering motor.

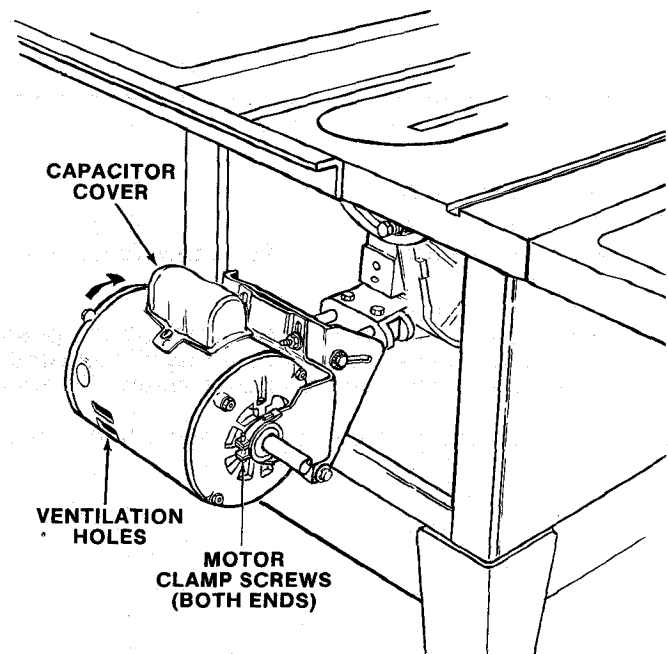

MOTOR CONNECTIONS

WARNING: FOR YOUR OWN SAFETY, NEVER CONNECT PLUG TO POWER SOURCE OUTLET UNTIL ALL ASSEMBLY STEPS ARE COMPLETED

1. Open motor connector box cover located on left end of motor (viewed from rear of saw) using a flat blade screwdriver.
2. Remove GREEN SCREW and lockwasher and insert screw through round metal terminal on the end of the GREEN wire of power cord with lockwasher between terminal and motor frame. (See illus.)
3. Reinsert GREEN SCREW in the threaded hole. Tighten securely.
4. Insert terminal end of WHITE wire on spade terminal marked T4 on the motor. Push terminal firmly until seated.
5. Insert terminal end of BLACK wire on spade terminal marked T1 on the motor. Push terminal firmly until seated.
6. Close motor connector box being sure that power cord is seated in the largest strain relief groove, and tighten box cover screws.

WARNING: Do not plug in power cord.

7. Do not install pulley or belt at this time.

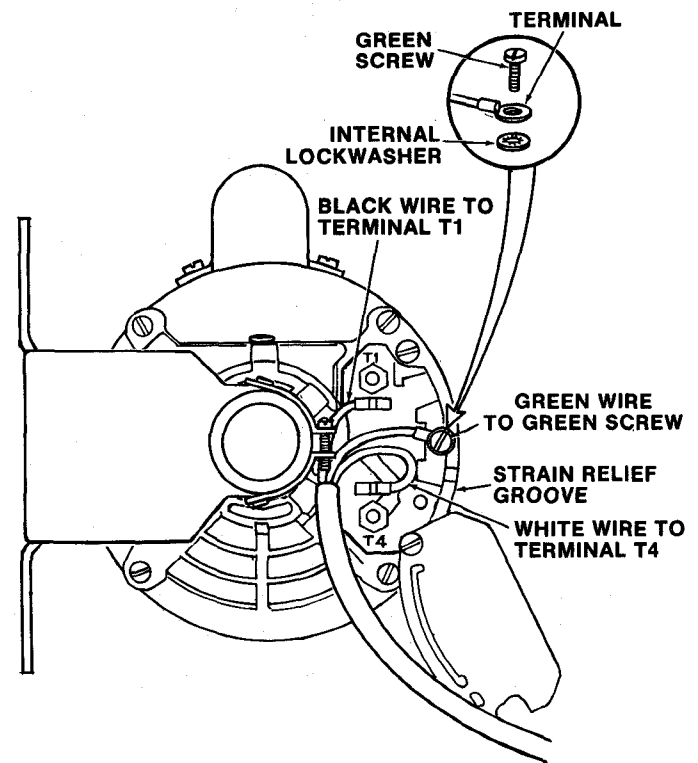

ATTACHING AND ASSEMBLING TABLE EXTENSIONS

If you received Table Extensions with your saw attach them at this time.

From among the loose parts find the following hardware: (Quantity indicated is for 2 extensions)

Ref. No.	Description	Qty.
1	Corner Support Bracket	4
2	Corner Stiffener Bracket	4
3	Truss Hd. Screw, 1/4-20 x 1	16
4	External Lockwasher, 1/4	16
5	Hex Nut, 1/4-20	16
6	Flat Washer (Dia. of Hole 17/64)	4

HARDWARE FOR INSTALLING EXTENSIONS TO SAW TABLE

7	Hex Hd. Screw, 5/16-18 x 1-1/4	8
8	External Lockwasher, 5/16	8
9	Hex Nut, 5/16-18	8
10	Flat Washer (Dia. of Hole 11/32)	8

Assemble brackets with hardware as listed.

Insert eight (8) 5/16-18 x 1-1/4 in. long screws through holes in EXTENSION then through table. Install flat washer, lockwashers, and screw on the nuts . . . DO NOT TIGHTEN.

Align front edge of extension with front edge of saw table. Pull Extension UPWARDS above table surface . . . SLIGHTLY TIGHTEN SCREWS using 1/2 in. wrench.

Using small block of hardwood and hammer, tap extension DOWNWARDS at front, center and rear, until it is EVEN with table surface . . . TIGHTEN SCREWS.

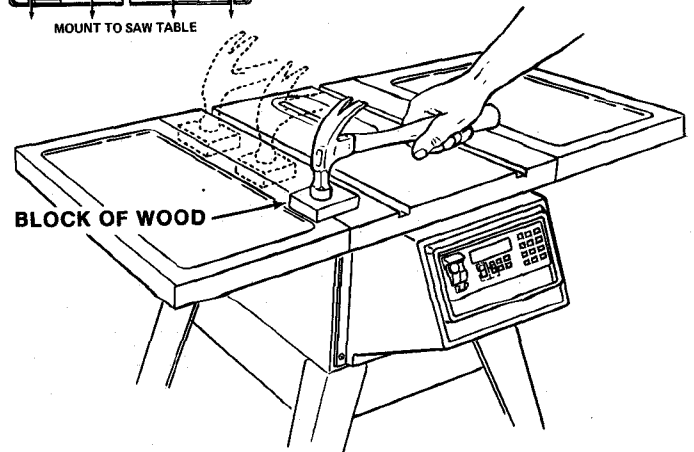
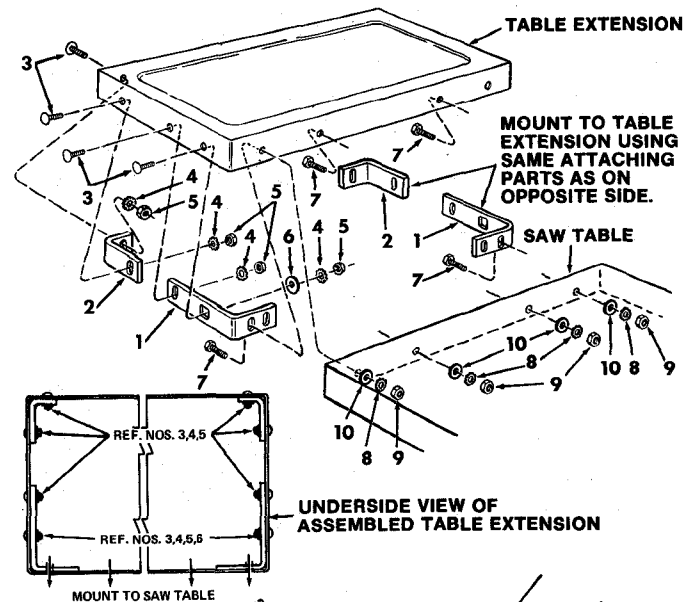

Lay REAR FENCE GUIDE BAR on table to act as a straightedge. If outer edge of extension is higher or lower than table surface:

- Slightly loosen nut holding the corner support bracket to extension using 7/16 in. wrench.
- Move end of extension up or down until outer edge is even with table surface . . . check with GUIDE BAR . . . tighten nuts.
- Recheck INNER edge of extension to make sure it has not moved . . . readjust, if necessary.

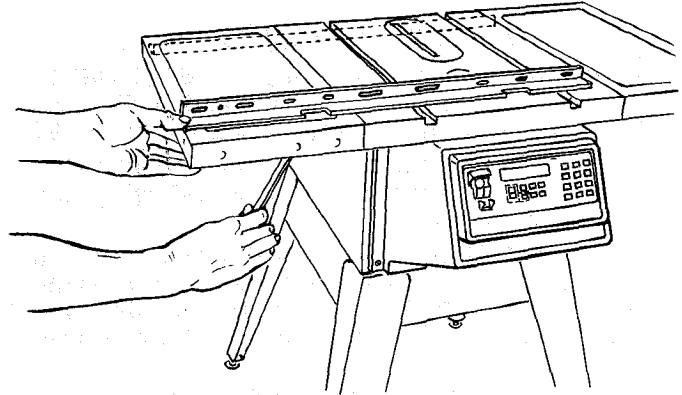

INSTALLING RIP FENCE GUIDE BARS

- From among the loose parts find the following hardware:

- 2 Hex Head Screws, 5/16-18 x 1-3/4 in. long
- 2 Hex Head Screws, 5/16-18 x 1 in. long
- 4 External Lockwashers, 5/16 in. (approx. dia. of hole 5/16 in.)
- 4 Hex Nuts, 5/16-18 (approx. dia. of hole 5/16 in.)
- 2 Spacers, 3/4 in. dia. x 1/2 in. long
- 2 Self-threading nuts
- 1 Fence Guide Bar Rod

- Lay guide bars on saw table.

NOTE: The various holes in the bar allow them to be positioned on this saw and also makes them adaptable to other models.

- Insert a 1-3/4 inch long screw through the THIRD hole from LEFT IN THE FRONT BAR . . . Insert another 1-3/4 inch long screw through the SEVENTH hole in bar.
- Place spacers on screws.

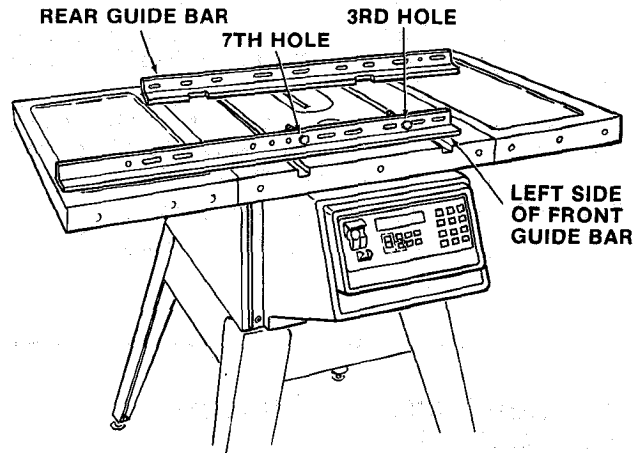

- Turn front bar end for end and insert bolts through holes in middle and on right side of front of saw table as illustrated . . . install lockwashers and nuts. **DON'T SCREW NUTS ON ALL THE WAY**, just get them started on the screws.

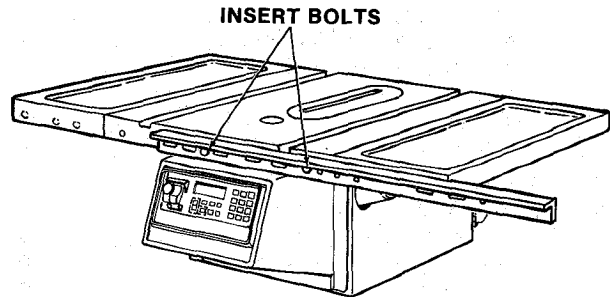

- Remove the 3 screws from rear of right table extension.
- Insert 1 in. long screws in SECOND and FOURTH holes of rear bar and attach to table the same way as front bar.
- Insert ends of FENCE GUIDE BAR ROD through holes in bars as illustrated.

NOTE: The ends of the ROD are not threaded . . . the SELF THREADING NUTS will cut threads on the rod as they are screwed on.

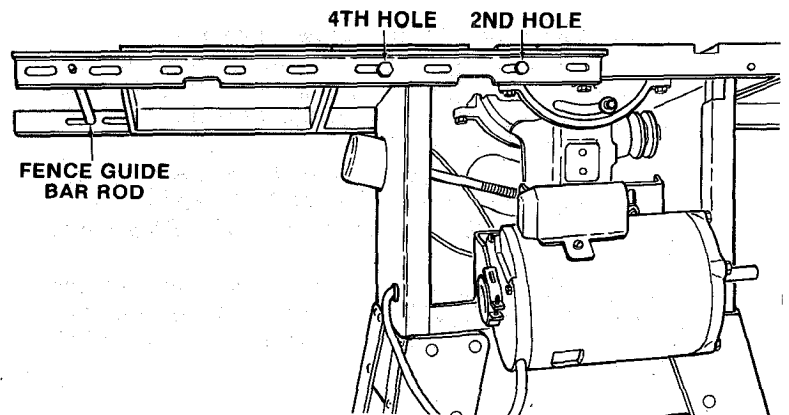

9. Hold rod with one hand and with a 1/2 in. wrench or pliers start screwing on ONE of the nuts only A TURN OR TWO . . . screw on other nut the same way.
10. Using TWO 1/2 in. wrenches or pliers tighten both of the nuts.

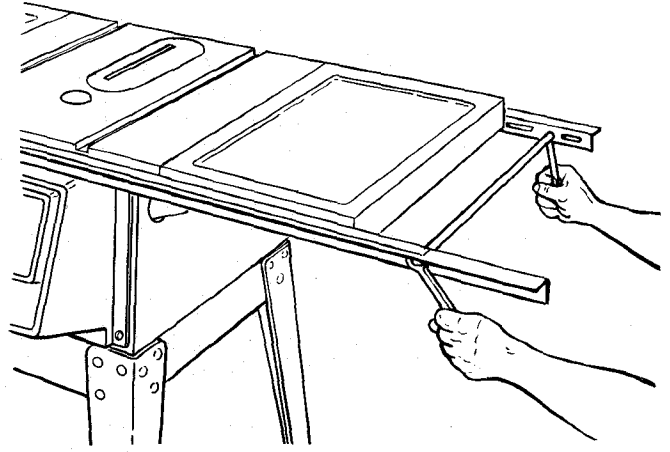

11. Slide the bars so that screws are in the MIDDLE of the slotted holes.
12. Position rip fence over miter gauge groove, holding up the rear end while engaging front end with bar . . . lower fence onto table.

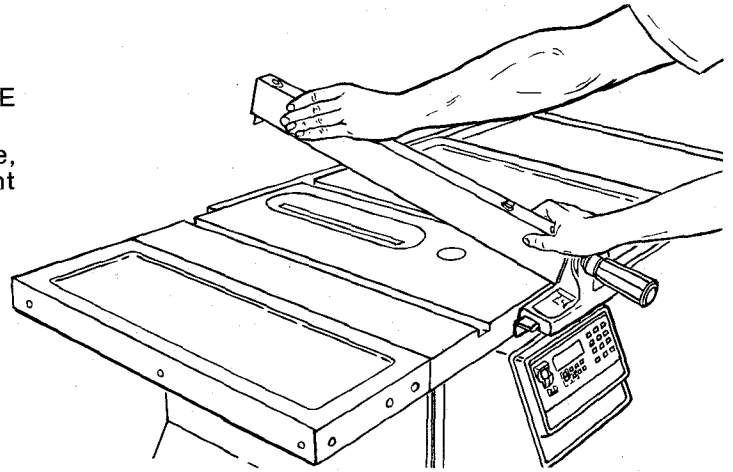

13. Plug saw into power outlet.
14. Insert yellow key into MASTER switch and turn on.
15. Press **ELEV** key. A "E" will be displayed.
16. Press and hold jog key **JOG** to raise sawblade about 3 inches above table surface. Release key.

NOTE: Display will not show elevation or angle until saw is "calibrated". This is described after assembly is complete.

17. Press **BEVEL** key.

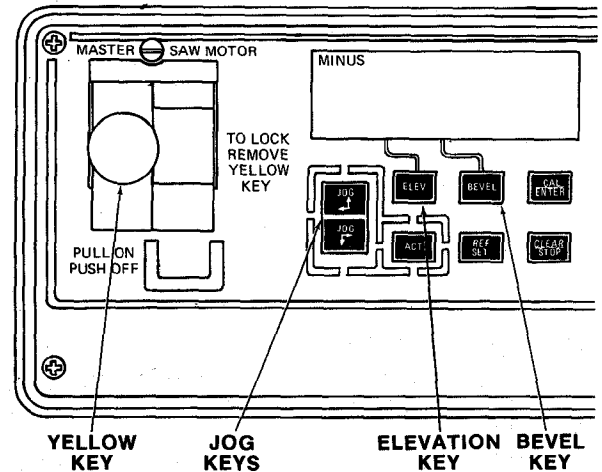

18. Place a square against the blade. Make sure square is not touching the TIP of one of the saw TEETH.
19. Press and release **JOG** and **JOG** keys to bring blade square with table.
20. Turn switch off and remove yellow key.
21. Remove plug from power source.

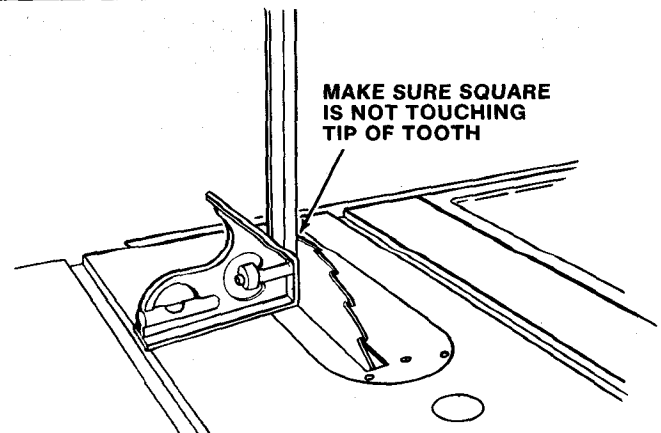

22. Carefully move fence against blade.
23. Move front bar until "0" mark on rip scale is approximately inline with indicator.
Move FRONT bar upwards until fence is approximately 1/32 in. above table . . . tighten screw at left end of bar.

NOTE: Fold a piece of newspaper making 8 thicknesses and place between rip fence and table to act as a spacer. This will hold the fence off of the table approx. 1/32 in.

24. Adjust rear bar so that the fence is approximately 1/32 in. above table. Make sure it is square with fence guide bar rod . . . tighten screw at end of bar.
25. Replace 3 screws in rear of table extension . . . be sure top surface of extension is PARALLEL to top surface of rear guide bar.

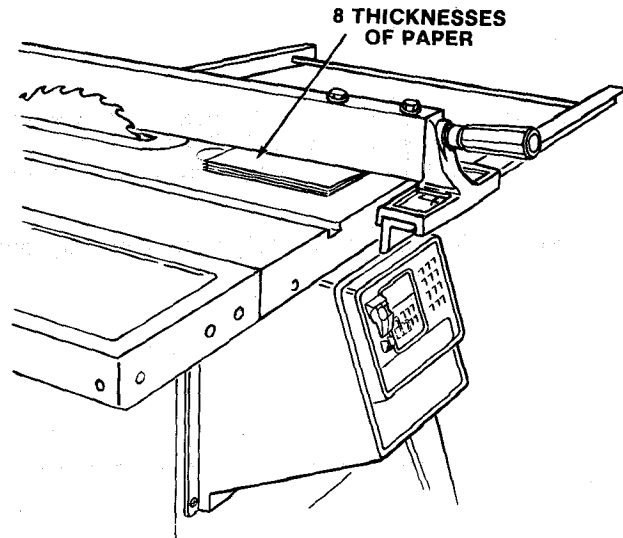

26. Move fence to RIGHT edge of saw table . . . make sure it is approx. 1/32 in. above table at front and rear and tighten screws in front and rear guide bars.

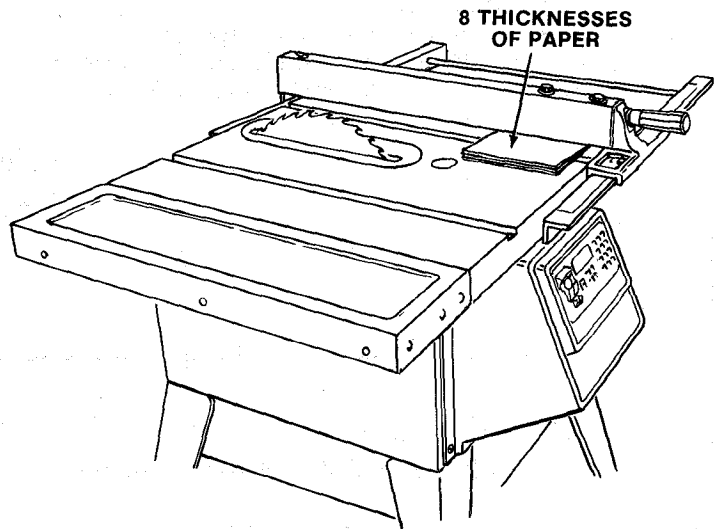

ALIGNING RIP FENCE

The fence should slide easily along the bars and always remain in alignment (parallel to sawblade and miter gauge grooves).

The alignment is maintained by a spring underneath the fence which bears against the front guide bar. To move the fence, loosen the lock handle and grasp the fence with one hand at the front.

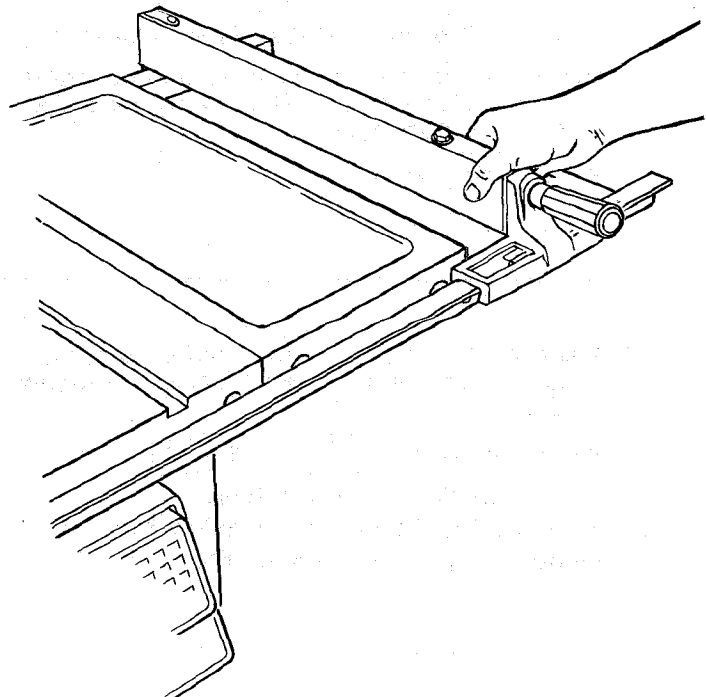

For very close adjustments, grasp the guide bar with both hands and move the fence with your thumbs.

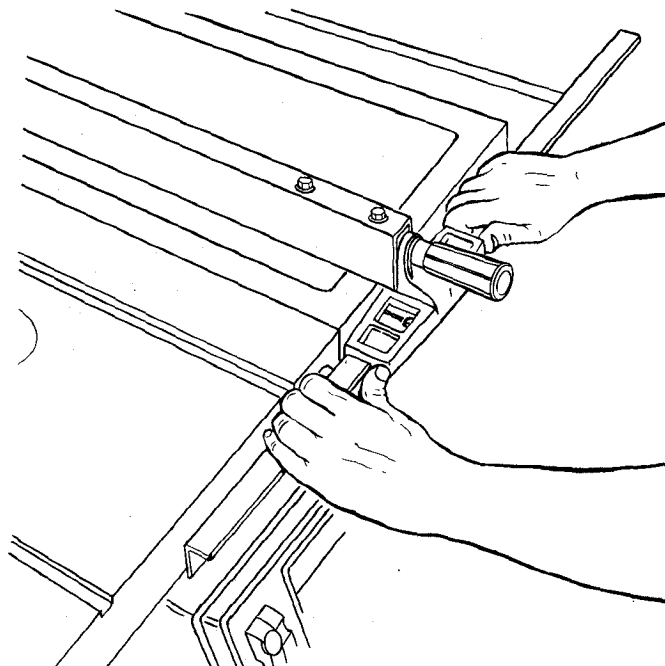

With fence on saw but NOT LOCKED move the REAR END of the fence slightly to the right or left ... when you release it, the fence should "spring" back to its original position.

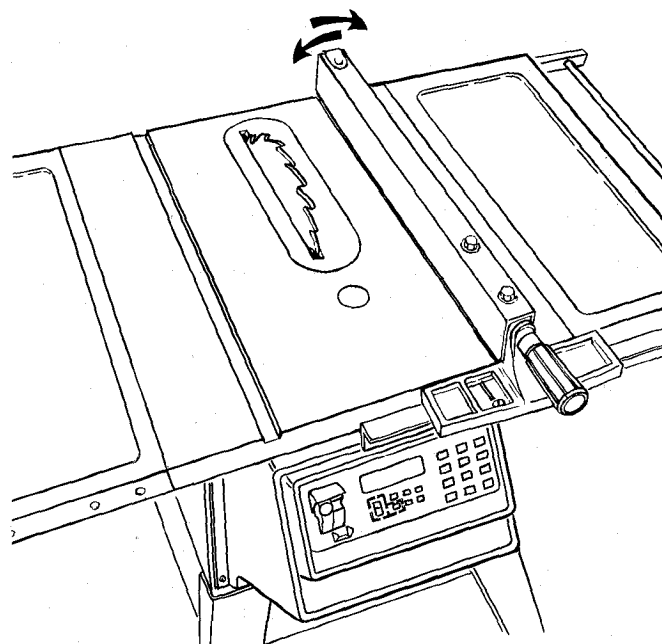

If it does not, the spring pressure must be INCREASED.

1. Loosen the screws.
2. Move Spring slightly toward front of fence ... tighten screws.

If the fence does not slide easily along the bars, the pressure of the spring can be REDUCED.

1. Loosen the screws.
2. Move spring slightly toward rear of fence ... tighten screws.

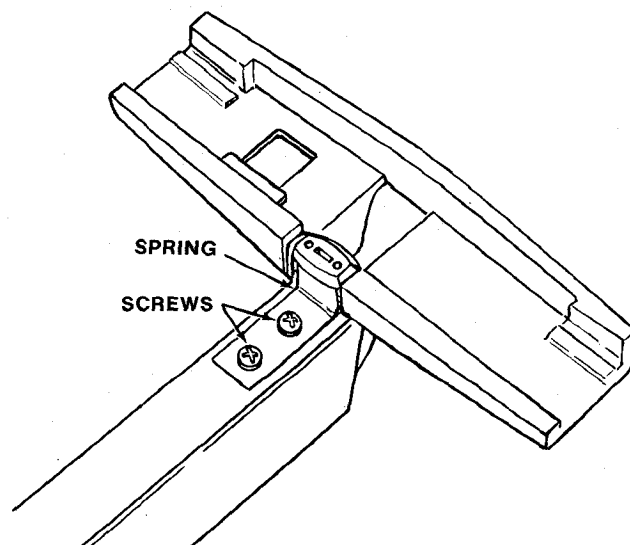

3. The rip fence must be PARALLEL with the sawblade and miter Gauge grooves . . . Move fence until it is along side of groove. DO NOT LOCK IT. It should be parallel to groove. If it is not:

- A. Loosen the two "Hex Head Screws."
- B. Hold fence head tightly against bar . . . move end of fence so that it is parallel with groove.
- C. Alternately tighten the screws.

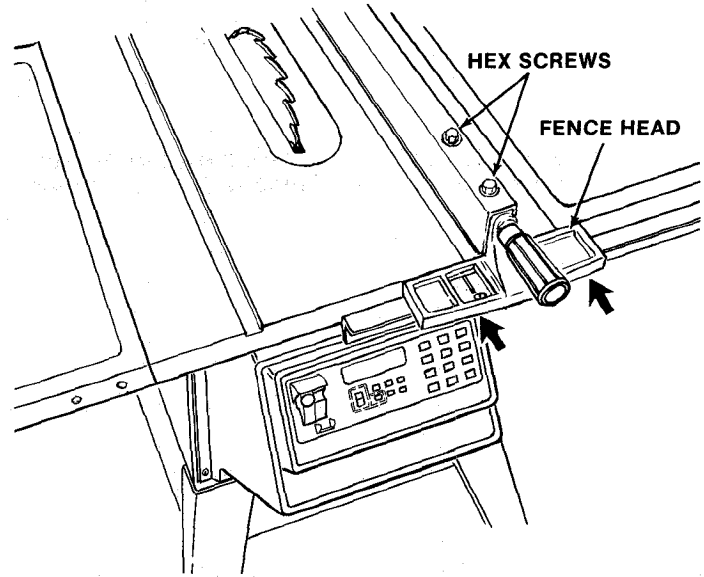

HEELING ADJUSTMENT or PARALLELISM OF SAWBLADE TO MITER GAUGE GROOVE

While cutting, the material must move in a straight line PARALLEL to the SAWBLADE . . . therefore the sawblade must be parallel to both the miter gauge GROOVE and the RIP FENCE.

If the sawblade IS NOT parallel to the miter gauge groove, the blade will bind at one end of the cut. (This is known as "HEELING"). Check the sawblade as follows.

WARNING — FOR YOUR OWN SAFETY MAKE CERTAIN THAT SWITCH IS "OFF" AND POWER CORD IS REMOVED FROM POWER SOURCE OUTLET BEFORE CHECKING OR ADJUSTING SAW.

1. Mark an "x" on one of the teeth which is SET (bent) to the LEFT.
2. Place the head of a combination square in the GROOVE . . . adjust blade of square so that it just touches the tip of the MARKED tooth. Lock the blade of the square.
3. Move square to REAR, rotate blade to see if MARKED tooth again touches blade of square.
4. If tooth touches square at FRONT and REAR . . . sawblade is PARALLEL to MITER GAUGE GROOVE.

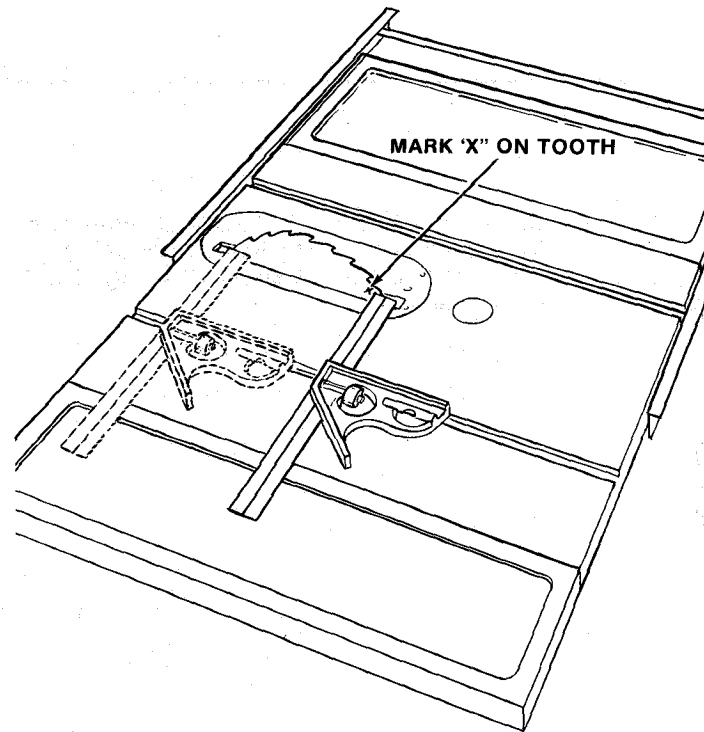

5. If tooth does not touch the same amount . . . the mechanism underneath must be adjusted to make the blade PARALLEL to GROOVE.

- A. Rear trunnion must be moved TOWARD the combination square if there is a space between marked tooth and end of square in step 4.
- B. Rear trunnion must be moved AWAY from the square if marked tooth pushes square out of position in the groove.

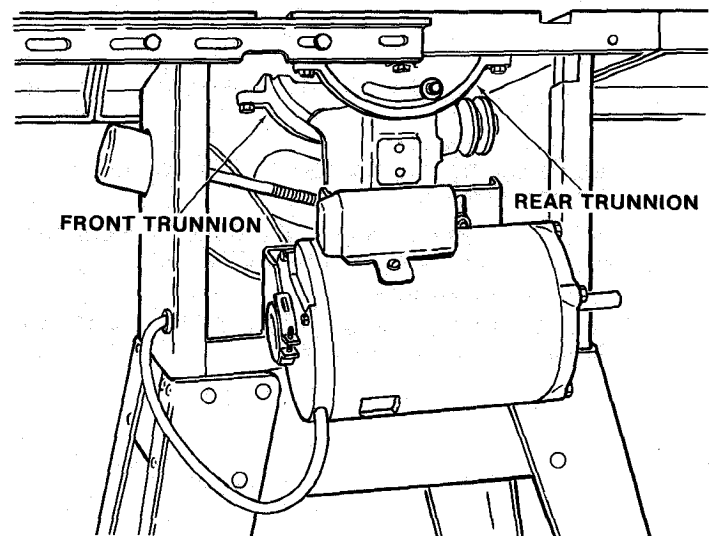

NOTE: All six screws can be reached through back of saw. Use a 9/16-in. wrench. To reach left-hand front trunnion screws, tilt blade to approximately 25°. After loosening screws reposition blade at 90°.

To make this adjustment:

- a. Plug saw into power outlet.
- b. Insert yellow key into MASTER switch and turn on.
- c. Press **BEVEL** key.
- d. Press and hold **JOG** key to tilt sawblade to approximately 25° to obtain clearance for wrench.
- e. Turn switch off. Remove yellow key.
- f. Loosen all three screws that hold the rear trunnion and all three screws that hold the front trunnion.
- g. Insert yellow key into MASTER switch and turn on.
- h. Press **BEVEL** key.
- i. Press and hold **JOG** key to reposition blade at 90° using a square.
- j. Turn switch "OFF", remove yellow key and unplug saw.

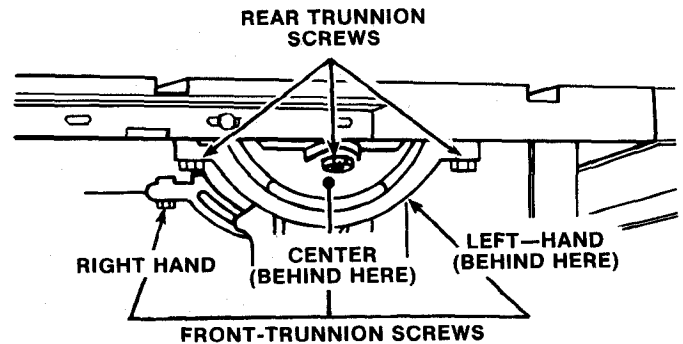

6. Using a wood block and mallet as shown, move rear trunnion to right or left as required to realign the blade. If necessary, shift front trunnion in similar manner; but do NOT move front trunnion unless necessary. Recheck the alignment with the square.
7. Securely tighten all six trunnion screws following previous steps to tilt blade to obtain clearance for wrench.
8. Recheck alignment after tightening screws. Readjust as needed.

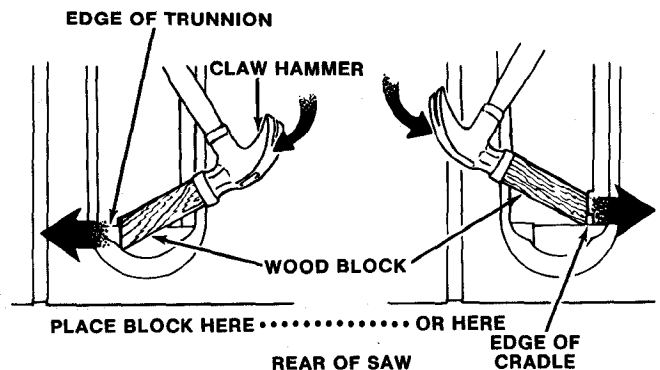

ADJUSTING RIP SCALE INDICATOR

IMPORTANT: BLADE must be SQUARE (90°) to TABLE, in order to ALIGN rip fence.

1. Using a rule, position fence on right side of sawblade 2 in. from the sides of the teeth . . . tighten lock handle.
2. Loosen screw holding the indicator . . . adjust so that it points to "2" on the rip scale . . . tighten screw.

NOTE: If you cannot adjust indicator so that it points to "2", loosen the screws holding the front guide bar and move the guide bar.

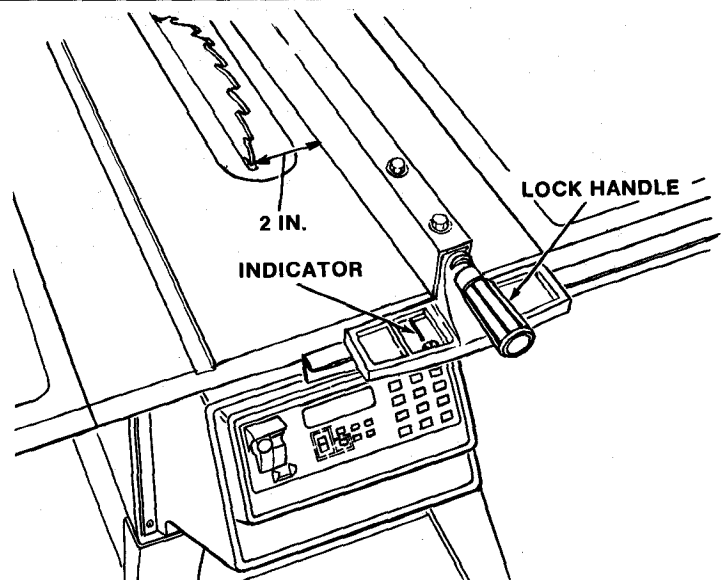

INSTALLING BLADE GUARD

- From among the loose parts, find
 - 2 Hex Head Screws, 1/4-20 x 5/8 in. long
 - 1 Hex Head Screw, 5/16-18 x 5/8 in. long
 - 2 Hex Head Screws, 5/16-18 x 1 in. long
 - 2 Hex Nuts, 1/4-20
(approx. dia. of hole 1/4 in.)
 - 2 Lockwashers, 1/4 in. External Type
(approx. dia. of hole 1/4 in.)
 - 2 Lockwashers, 5/16 in. External Type
(approx. dia. of hole 5/16 in.)
 - 1 Thumbscrew
 - Guard Support
 - Spreader Support
 - Spreader Rod

- Attach **GUARD SUPPORT** . . . **DO NOT TIGHTEN** screws.
- Assemble 5/16-18 x 5/8 hex head screw into **GUARD SUPPORT**.

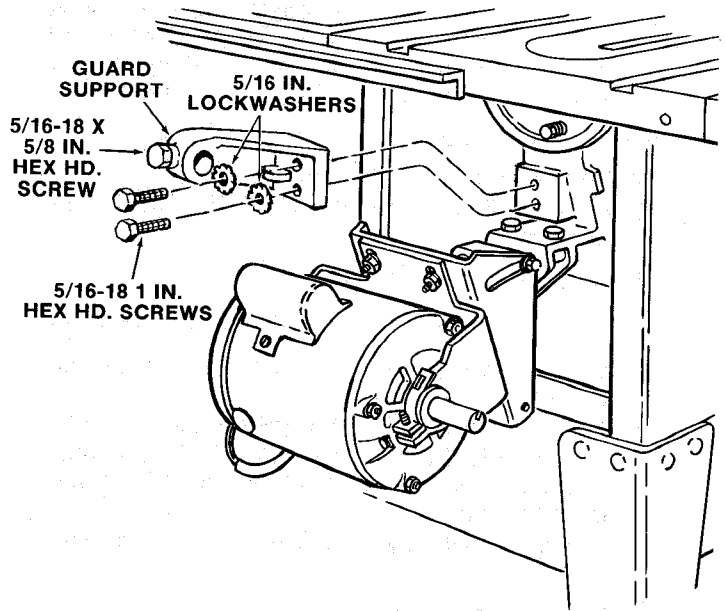

- Insert **SPREADER ROD** into **SPREADER SUPPORT** until pin fits into notch. Insert Thumbscrew and tighten it.

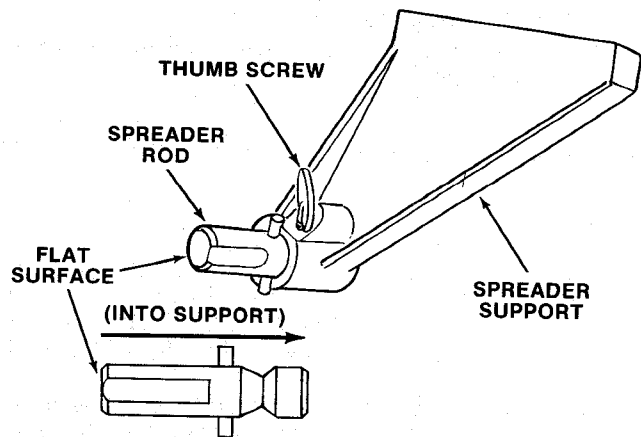

- Slide **SPREADER ROD** into **GUARD SUPPORT** until left end of **ROD** extends approximately 1/4 inch beyond edge of **SUPPORT** . . . Snug up Hex Head Screw in **SUPPORT**.
- Attach **SPREADER** to **SPREADER SUPPORT** so that screws are all the way back in the **SLOTS** of **SUPPORT** . . . tighten screws.
- Raise **ANTIKICKBACK PAWLS** (hold in place with a setscrew wrench. See next illustration). Align spreader **SQUARE** to table (be sure insert is properly adjusted).

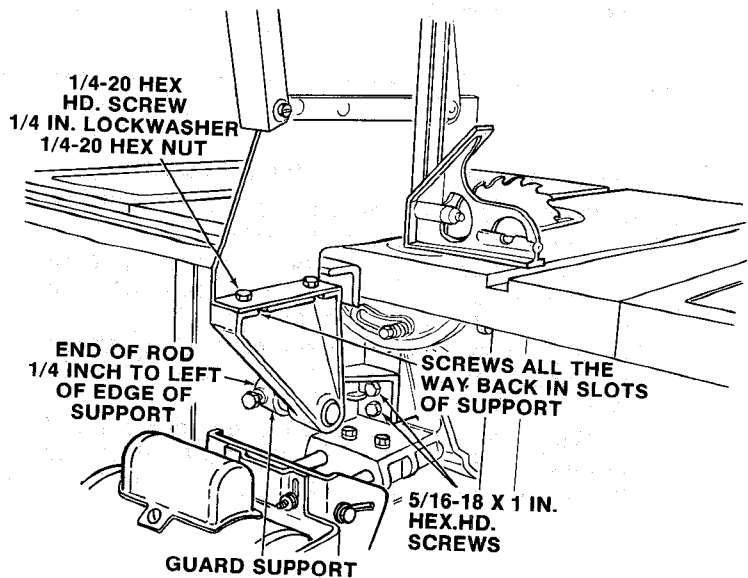

8. Raise Blade Guard . . . lift up both ANTIKICKBACK PAWLS . . . insert one of the SETSCREW WRENCHES in the notches to hold the pawls out of the way.
9. Lay blade of square or other straightedge alongside of blade.
10. Loosen Hex Head Screw in GUARD SUPPORT and move spreader so that it touches blade of square . . . tighten screw.
11. **NOTE:** The spreader is now square with the table and approximately in line with the sawblade. The spreader requires further adjustment to align it PARALLEL to the blade and in the MIDDLE of the cut (KERF) made by the sawblade.

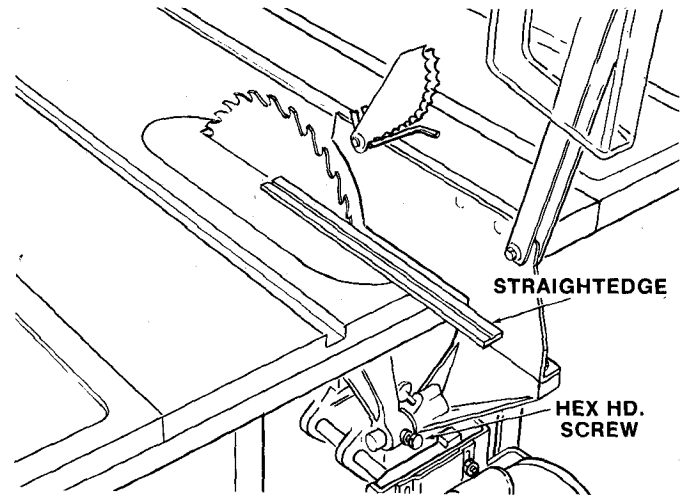

12. **IMPORTANT:** The SPREADER must always be PARALLEL to the sawblade in the MIDDLE of the cut (KERF) made by the sawblade.
NOTE: The spreader is thinner than the width of the KERF by approximately six thicknesses of paper.

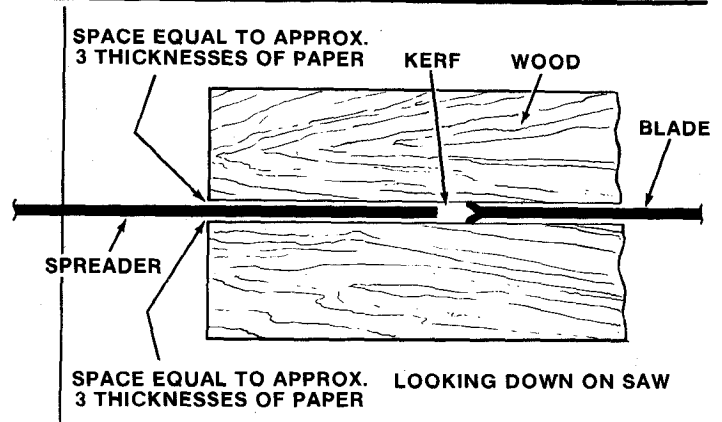

13. Make two folds in a small piece (6 x 6 in.) of ordinary NEWSPAPER making three thicknesses.
The folded paper will be used as a "spacing gauge".

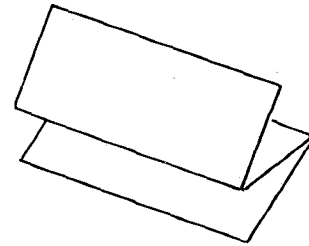

14. Place RIP FENCE on table . . . CAREFULLY move it against blade so that it is parallel to the blade, and just TOUCHES tips of saw teeth . . . tighten RIP FENCE LOCK KNOB HANDLE.
15. Insert folded paper between SPREADER and FENCE . . . hold spreader flat against fence . . . tighten screws using 7/16 in. wrench. Now tighten Hex Hd. Screws in Support.
16. To remove BLADE GUARD AND SPREADER, loosen THUMBSCREW . . . DO NOT LOOSEN OTHER SCREWS.

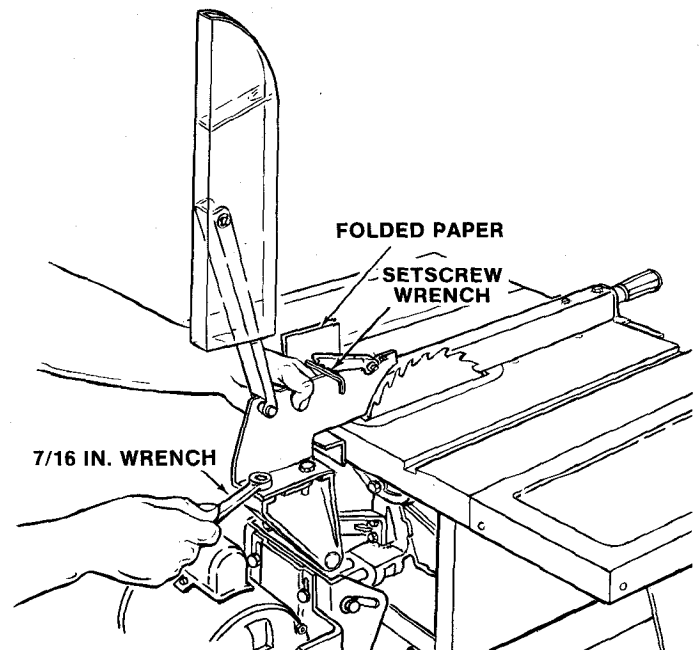

INSTALLING BELT GUARD SUPPORT

1. Screws furnished with guard are "self threading" . . . screw them into holes in BELT GUARD SUPPORT BRACKET, then remove them.
2. Position BELT GUARD SUPPORT BRACKET and BELT GUARD SUPPORT as shown and install the screws . . . make sure motor shaft is in CENTER of hole in SUPPORT.

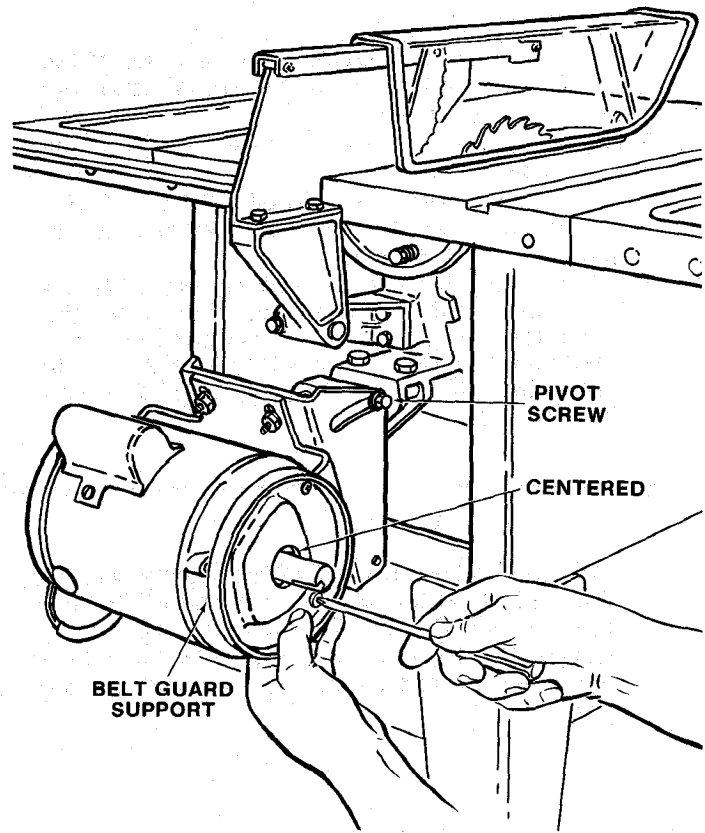
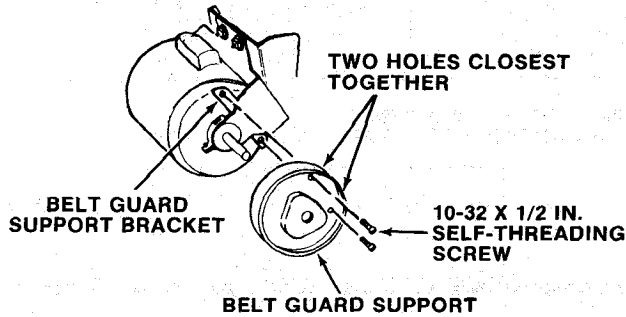



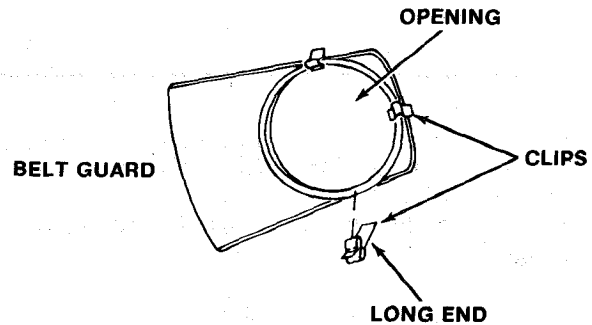

3. Install three CLIPS (furnished with guard) 90° apart starting with one clip at the end of the guard as shown . . . LONG END of clip facing AWAY from you.
4. Do not assemble belt guard to belt guard support at this time.

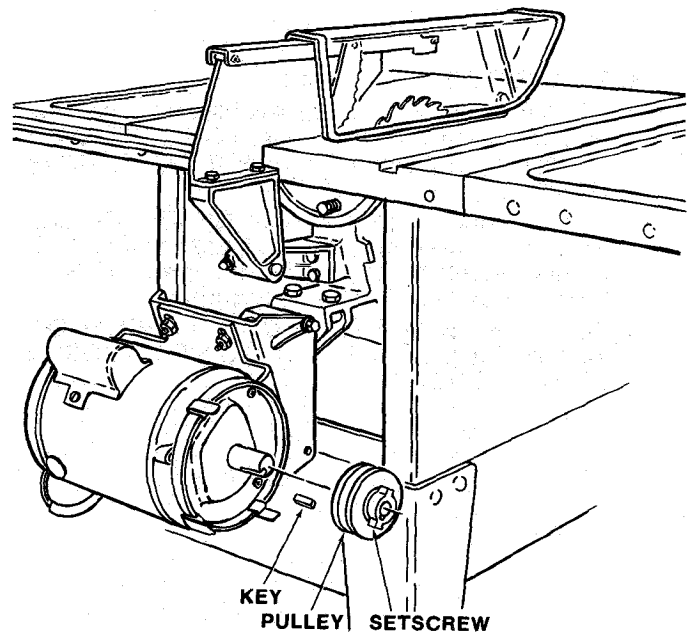

INSTALLING MOTOR PULLEY AND BELT

1. Loosen set screw in motor pulley using 5/32 in. setscrew wrench. Slide pulley on shaft with HUB away from motor. DO NOT TIGHTEN SETSCREW.
2. Install 3/16" in. square key (in loose parts) in grooves in pulley and motor shaft. DO NOT TIGHTEN SETSCREW at this time.



3. Loosen two motor base clamp screws . . . push motor in as far as it will go.
4. a. Plug in saw, turn MASTER switch "ON".
b. Press  key.
c. Press and hold  key to lower blade even with table top.
- d. Turn MASTER switch "OFF", remove yellow key and unplug saw.
5. Install belt on motor pulley and saw pulley.
6. Sight along edges of both pulleys and move motor pulley so that belt is parallel to the edges of both pulleys . . . tighten the setscrew in the motor pulley.
7. Make sure blade is 90° to table . . . raise it all the way up using procedure in Step 4 except holding the  key.
8. Lift motor until edge of washer is even with end of slot . . . tighten pivot screw. In this position, pull motor toward you (pins will slide out of cradle) until belt is TIGHT . . . tighten the two MOTOR BASE CLAMP SCREWS.
9. Loosen Pivot Screw slightly.
10. Lower the saw blade all the way down following procedure in Step 4 above.
11. **IMPORTANT:** Motor should pivot freely

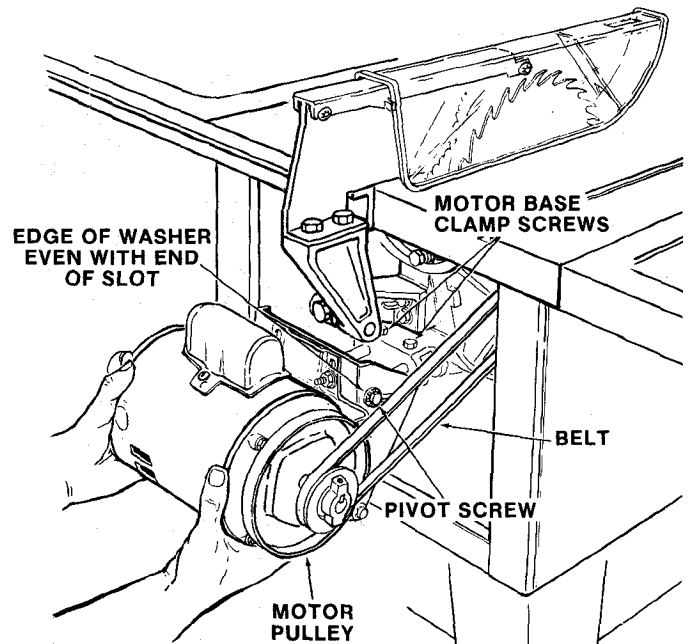

downward as blade is lowered. If it does not, LOOSEN the PIVOT SCREW some more.

12. Pivot screw must be adjusted only tight enough to allow motor to pivot FREELY as blade is raised or lowered. This will maintain constant tension on belt.

13. Remove belt from motor pulley. Insert end of belt through opening in end of belt guard and install belt on pulley.

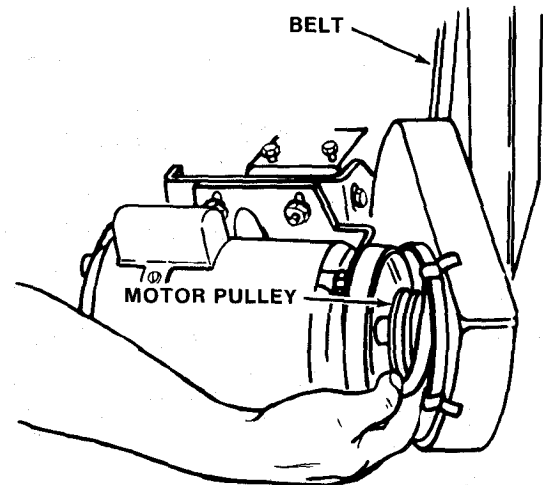

14. Press guard onto support so that bottom of guard is approximately 3/4 in. away from belt with blade all the way down.

NOTE: To remove guard, lift up on LONG TABS of clips . . . pull guard outward. The clips should remain on the BELT GUARD SUPPORT.

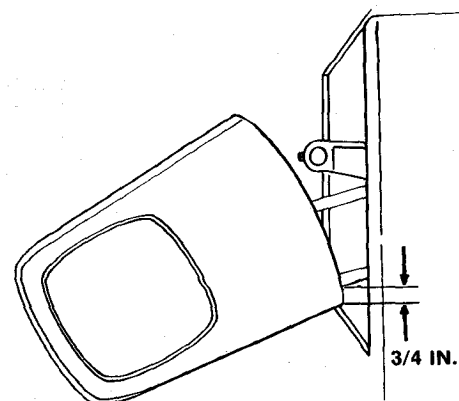

MITER GAUGE

NOTE: The slots for the Stop Pin and the angle graduations are manufactured to close tolerances which provide accuracy for most woodworking projects. In cases where greater accuracy is required, it is recommended that a trial cut be made and checked before cutting the actual workpiece.

Before using the miter gauge, check that the head of the miter gauge is square to its bar when the Stop Pin is indexed at 0° and the Lock Knob tightened. If the head is not square with the bar, an adjustment will be required.

To adjust the squareness of the Miter Gauge:

1. Loosen the two screws that hold the Indicator Block 1/2 turn.
2. Loosen the Lock Knob.
3. Holding the Miter Gauge Bar and Head firmly against a square, tighten the Lock Knob. Recheck the squareness.
4. If the Head is square to the Bar, tighten the two screws for the Indicator Block while pushing the Stop Pin firmly into the 0° notch.
5. Align pointer with "0" mark on the head.

Looseness in the Miter Gauge Head can be removed by adjusting the set screw located on the underside of the Head. Rotate the Head to a 60° position and turn Miter Gauge upside down to reach the set screw. Use a 1/8" Hex L wrench to adjust. There should be no up and down movement in the Head when the Lock knob is loosened, yet it must swivel freely.

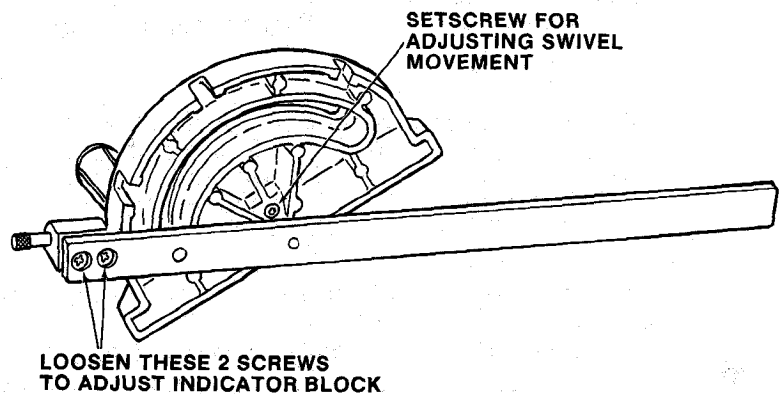
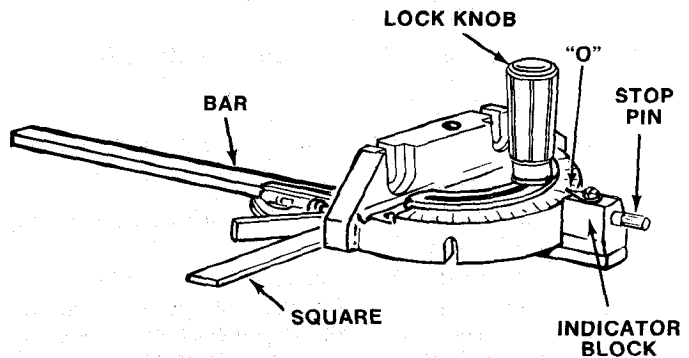

GETTING TO KNOW YOUR SAW

LOCATION AND FUNCTION OF ELECTRONIC CONTROLS

1. MASTER SWITCH

2. SAW MOTOR SWITCH

3. DISPLAY

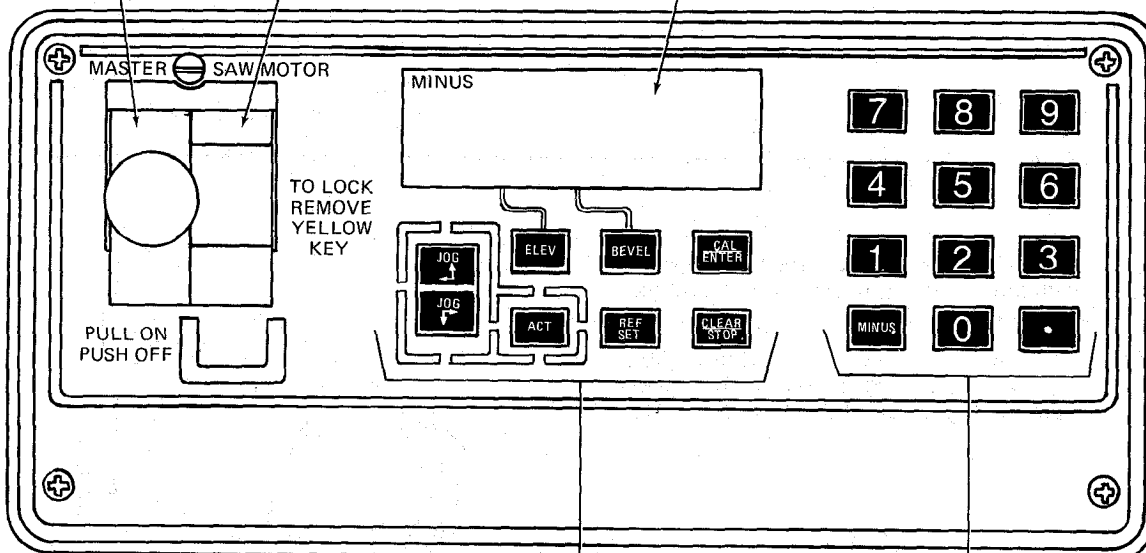

4. CONTROL KEYS

5. NUMBER KEYS

LOCATION AND FUNCTION OF MECHANICAL CONTROLS

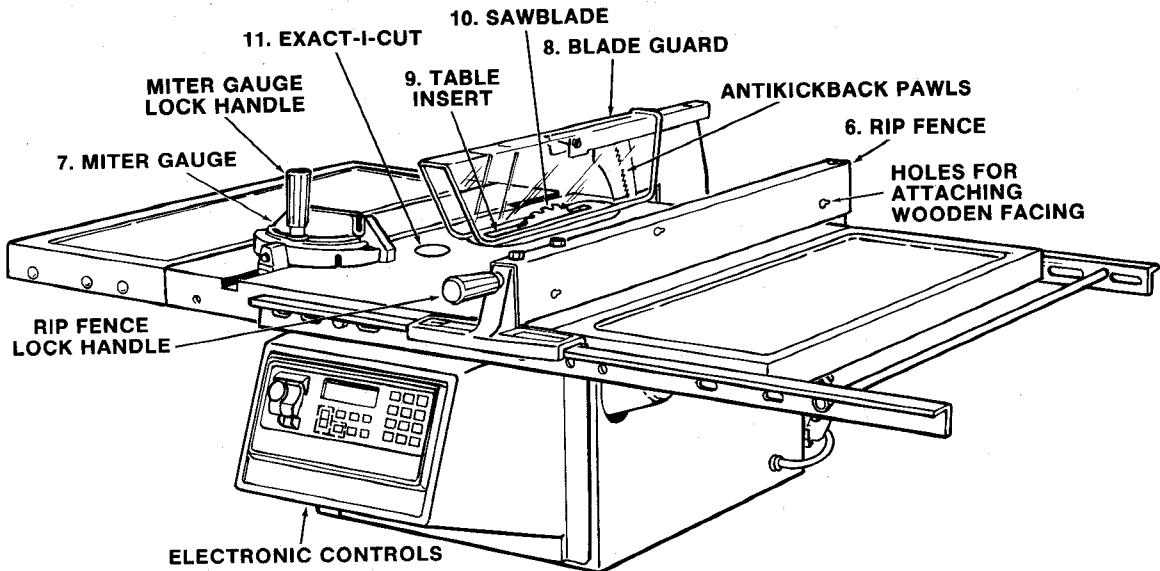

CAUTION: Before turning switch on, make sure the blade guard is correctly installed and operating properly.

1. MASTER SWITCH:

This is the power on-off switch for the computer's display and keyboard functions. (The computer's memory has constant power as long as saw is plugged into a 120v live power supply.) Turning this switch off will shut off power to the saw motor as well as the computer functions.



2. Insert finger under bottom of lever and pull out.

To turn switch off:
 Push lever in.

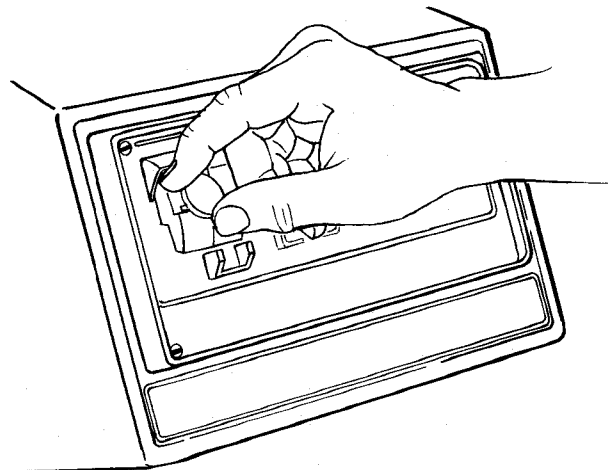

To turn switch on:
 1. Insert yellow key.

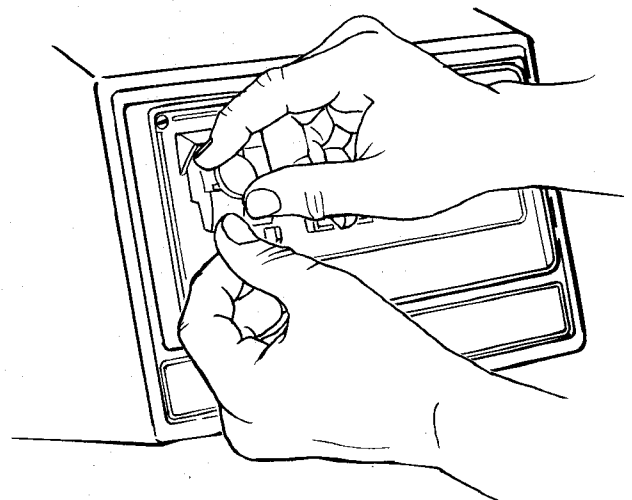

To lock switch:
 Hold lever in with one hand while removing yellow key with the other hand.

2. SAW MOTOR SWITCH:

This switch is used to turn the saw motor on and off.

NOTE: Pushing off either the Saw Motor Switch or the Master Switch will shut off power to the saw motor.

NOTE: Only the and JOG keys will work when the Saw Motor Switch is "ON". The elevation only is displayed as long as this switch is "ON".

Operation of this switch is the same as the Master Switch except for the yellow key.

WARNING: Do not stand in line with blade when turning switch on.

Do not cycle motor switch "ON" and "OFF" rapidly, as this may cause the sawblade to loosen. In the event this should occur, allow the sawblade to come to a complete stop and retighten the arbor nut normally, not excessively.

Never leave the saw with power "ON".

WARNING: FOR YOUR OWN SAFETY, LOWER BLADE OR OTHER CUTTING TOOL BELOW TABLE SURFACE. (IF BLADE IS TILTED, RETURN IT TO VERTICAL (0°) POSITION). ALWAYS LOCK THE SWITCH "OFF". WHEN SAW IS NOT IN USE... REMOVE KEY AND KEEP IT IN A SAFE PLACE... ALSO... IN THE EVENT OF A POWER FAILURE (ALL OF YOUR LIGHTS GO OUT) TURN SWITCH OFF... LOCK IT AND REMOVE THE KEY. THIS WILL PREVENT THE SAW FROM STARTING UP AGAIN WHEN THE POWER COMES BACK ON.

3. DISPLAY:

NOTE: Readout on display is in decimals. There is a conversion chart for converting fractions to decimals on page 55 of this manual.

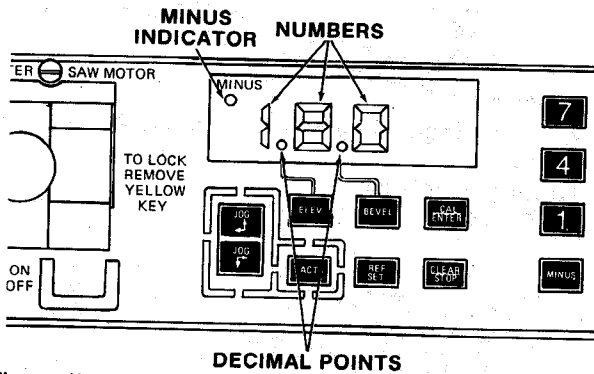

The display gives the user four pieces of information.

1. The **decimal point** shows what function, either ELEV OR BEVEL, is being displayed.
2. The **numbers** show either the present position of the blade or the entered destination for programmed operation.
3. The minus indicator in the upper left hand corner lights when the displayed number is negative (less than the "zero" position) or when the key is pressed after a number.
4. The flashing indicates that the saw needs calibrating. The flashing "E" will only be displayed when the saw requires calibrating

due to either a power interruption or the saw has been unplugged.

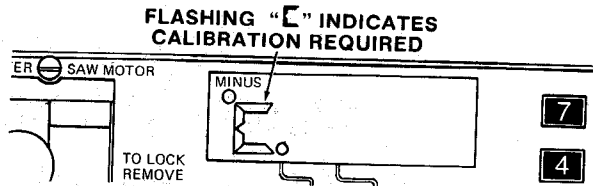

4. CONTROL KEYS:

The two rows of keys directly under the display are the control keys. They are how you tell the computer what you want it to do.

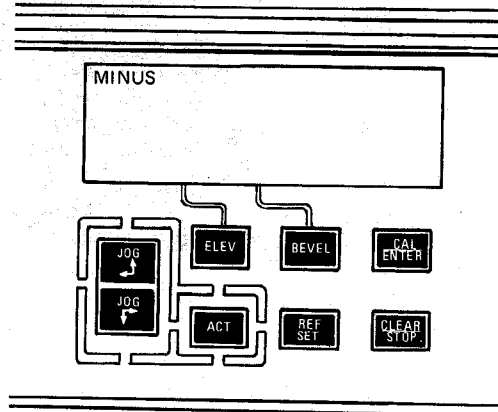

- A. Jog key is a rocker type switch that when pushed up and held in causes the blade to elevate when in or to bevel to the left when in . The motions are the opposite when the key is pushed down. When the jog key is pressed and immediately released it will cause the blade to change elevation by 0.005" or bevel by 0.1° depending on the function selected. This "tapping" of the jog key can be repeated as many times as desired to move blade into position.
- B. and keys are used to select the desired function. Pressing will display current blade elevation. Saw must be in elevation mode before any programmed or jogging elevation operation can be performed. A lighted decimal above key indicates that the elevation function is active. In the same way, pressing will display the current angle of the blade and allow any programmed or jogging bevel operation to be performed. A lighted decimal above indicates that the bevel mode is active.
- C. key is a dual purpose key. When the saw is first plugged in or if there has been a power interruption the key operates as a "Calibration" key. Pressing the key, with the

blade at 90° to the table and at zero elevation accurately sets the program that computes the elevation and bevel angle of the blade. Once the calibration has been set the key becomes an "Enter" key used for entering both a bevel and an elevation programmed motion.

D. The **ACT** key, when pressed, will start a programmed motion.

It becomes inactive while the saw motor is "ON".

E. The **REF SET** key will set the display to a "zero"

point other than at the table top, or when using a cutting tool less than 10 inches in diameter. See "Calibrating the Saw for Electronic Operations" Page 29.

F. The **CLEAR STOP** key will clear the display if an

error is made in a programmed entry and will return the display to the current position of the chosen function. This key will also stop a programmed motion once begun and clear the original destination.

5. NUMBER KEYS:

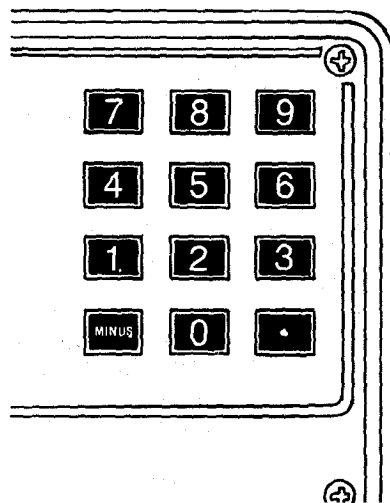

These keys include the number keys **0** through **9**, the decimal point **.** and **MINUS** keys. The number keys are used to enter a destination for programmed motion. The decimal point is used when entering the decimal part of the number.

The **MINUS** key is pressed after the numbers are entered if a destination is desired below the "zero" location.

A lighted dot in the upper left hand corner of the display indicates "minus."

6. RIP FENCE . . . is locked in place by tightening the lock knob. To move the fence, loosen the knob and grasp the fence with one hand at the front.

Holes are provided in the rip fence for attaching a wood facing when using the dado head, or molding head.

Select a piece of smooth straight wood approx. 3/4" thick, at least as long as the rip fence, and at least 7-1/2" wide (high) to permit clamping of featherboards.

Attach it to the fence with three Round Head #10 Wood Screws 2 in. long. To remove the facing, loosen the screws, slide the facing backward and pull the screws through the round holes.

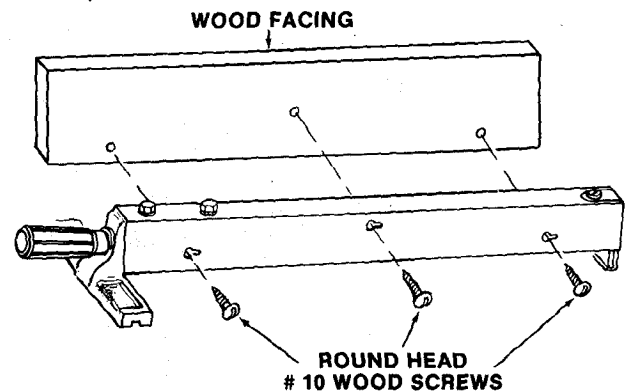

If you are making a rip type cut in material thinner than 3/16 in. while the fence is positioned over the depressed area of table extension, the facing should be attached to the fence so that the bottom edge touches the top surface of the extension. In this case, the facing must be shorter than the fence. This will prevent thin material from sliding under the rip fence.

7. MITER GAUGE . . . head is locked in position for crosscutting or mitering by tightening the lock knob. ALWAYS LOCK IT SECURELY WHEN IN USE.

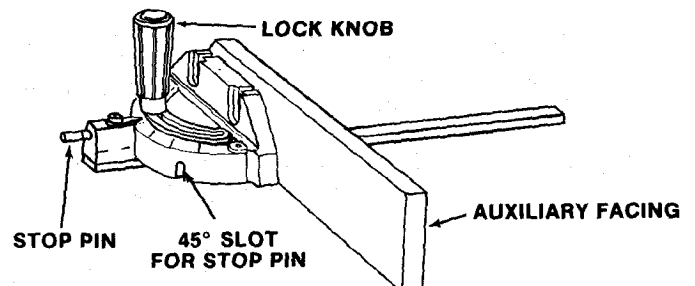

There are slots for the stop pin at the 45 degree right and left positions for conveniently setting the Miter Gauge to cut miters.

NOTE: The slots for the stop pin and the graduations are manufactured to very close tolerances which provide accuracy for average woodworking. In some cases where extreme accuracy is required, make a trial cut and then recheck it.

If necessary, the miter gauge head can then be swiveled slightly to compensate and then locked.

Slots are provided in the miter gauge for attaching AUXILIARY FACING to make it easier to cut long pieces. Be positive facing does not interfere with the proper operation of the sawblade guard.

Select a suitable piece of smooth straight wood . . . drill two holes through it and attach it with screws.

NOTE: When bevel crosscutting, attach facing so that it extends to the right of the miter gauge and use the miter gauge in the groove to the right of the blade.

8. BLADEGUARD must always be in place and working properly for all thru-sawing cuts. That is, all cuts where the blade cuts completely through the workpiece.

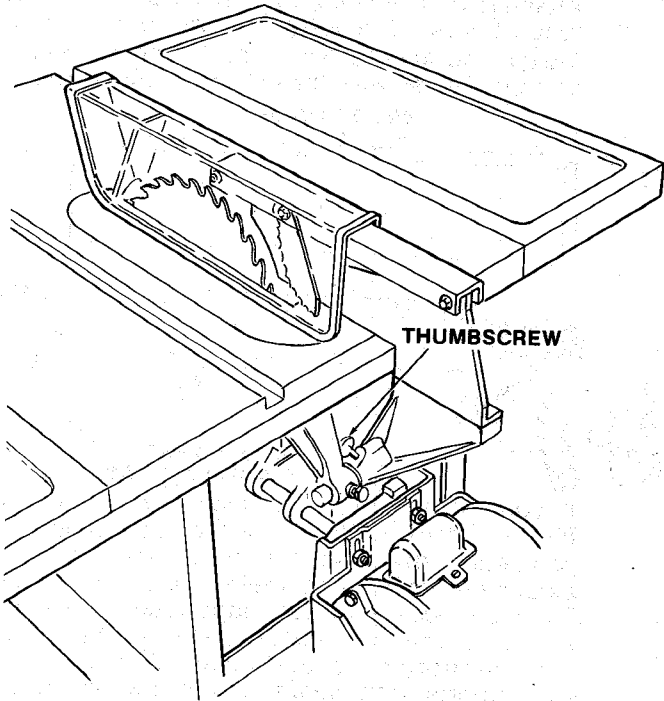

To remove the guard for special operations, loosen the thumbscrew and slide the guard off of the rod. **DO NOT DISTURB THE SETTING OF THE ROD.**

When replacing the guard, make sure the PIN in the rod engages with the NOTCH in the spreader support. Make sure thumbscrew is tightened securely.

9. TABLE INSERT is removable for removing or installing blades or other cutting tools.

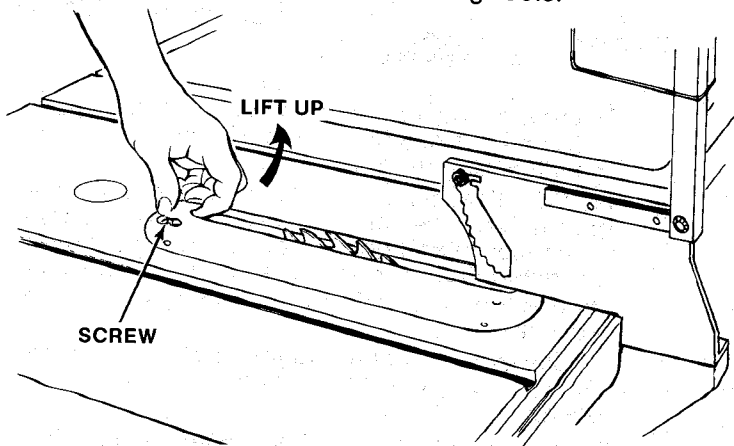

WARNING: FOR YOUR OWN SAFETY, TURN SWITCH "OFF" AND REMOVE PLUG FROM POWER SOURCE OUTLET BEFORE REMOVING INSERT

- A. Use "Shut Down Procedure" Page 30, to retain calibration.
- B. Raise blade guard.
- C. Loosen Screw.
- D. Lift insert from front end, and pull toward front of saw.

NEVER OPERATE THE SAW WITHOUT THE PROPER INSERT IN PLACE. USE THE SAW BLADE INSERT WHEN SAWING . . . USE THE COMBINATION DADO-MOLDING INSERT WHEN DADOING OR MOLDING.

10. REMOVING AND INSTALLING SAWBLADE
WARNING: FOR YOUR OWN SAFETY, TURN SWITCH "OFF" AND REMOVE PLUG FROM POWER SOURCE OUTLET BEFORE REMOVING OR INSTALLING SAWBLADE.

NOTE: If blade is above table when plug is removed from power source, it will be necessary to recalibrate the electronic function. See page 28.

- A. Raise Blade Guard . . . remove insert.
- B. To REMOVE blade, place a block of wood against front of blade . . . PULL arbor wrench toward you to LOOSEN arbor nut.

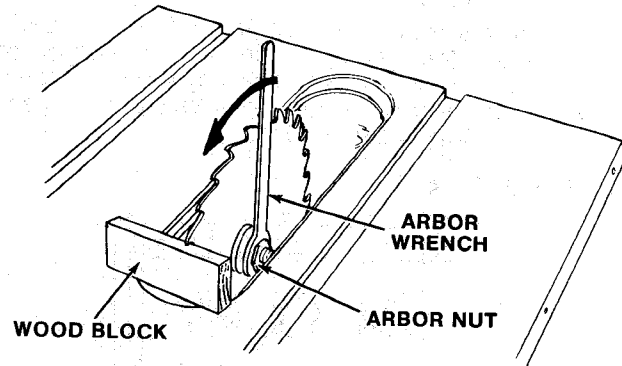

BLADE GUARD NOT SHOWN FOR PICTURE CLARITY

- C. To TIGHTEN arbor nut, place a block of wood against rear of blade . . . PUSH wrench away from you.

When installing the blade . . . make sure the teeth are pointing toward the front of the saw . . . and that the blade and collars are clean, and free from any burrs.

The HOLLOW side of the collar must be against the blade.

Always tighten the arbor nut securely.

BLADE GUARD NOT SHOWN FOR PICTURE CLARITY

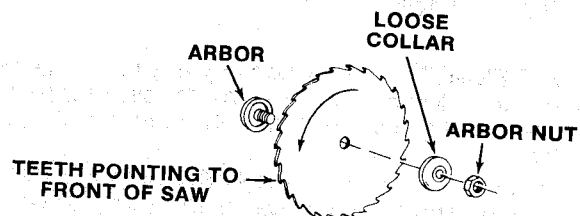
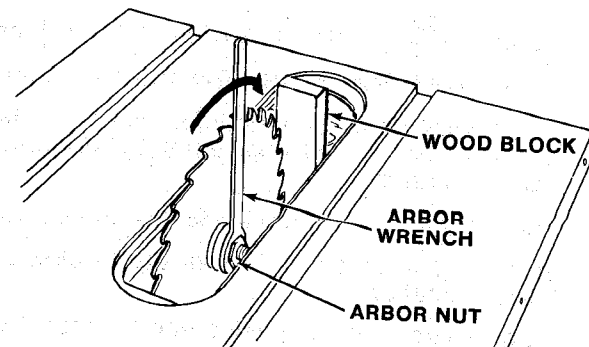

NOTE: When using the Dado or Molding Head, it is not necessary to install the loose collar. Refer to instruction sheet packed with dado or molding head.

To replace insert.

Place insert into insert opening in table and push toward rear of saw to engage spring clip and until keyslot in insert will drop over screw. Tighten screw.

Do not tighten screw to the point where it will deflect the insert.

11. EXACT-I-CUT

The "yellow" plastic disc imbedded in the table in front of the sawblade, is provided for marking the location of the "sawcut" on the workpiece.

SHOWN WITH HOLD-DOWN CLAMP (OPTIONAL ACCESSORY)

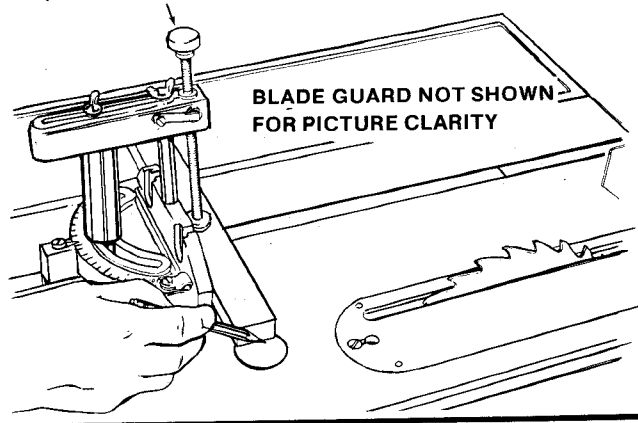

- Check disc . . . if it is above table surface, place a piece of hardwood on top of it and tap it down.
- With blade 90° (square to table) cut off a piece of wood.
- Pull miter gauge back until wood is over disc. Using very sharp pencil, mark a line on disc.
- With miter gauge in right hand groove, follow same procedure and mark another line on disc.
- These lines indicate the "path" of the cut (kerf) made by the sawblade.
- When cutting the workpiece, line up mark on workpiece with line on disc.

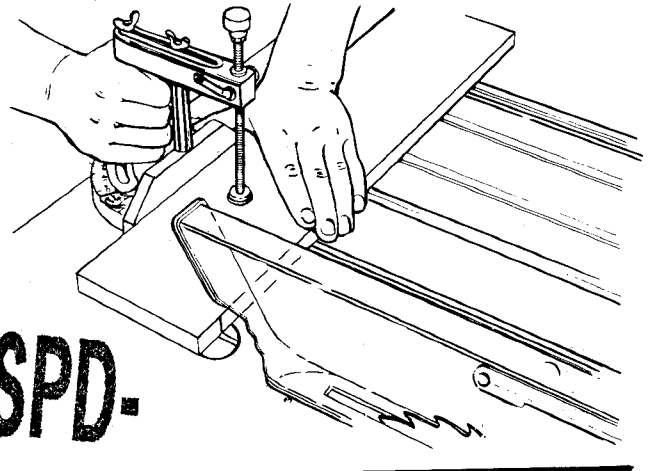

BASIC SAW OPERATION

WORK HELPERS

Before cutting any wood on your saw, study all of the "Basic Saw Operations".

Notice that in order to make some of the cuts, it is necessary to use certain devices called "Work Helpers" like the Push Stick, the Push Block and the Auxiliary Fence/Work Support, which you can make yourself.

After you have made a few practice cuts, make up these "helpers" before starting any projects. Make the "Push Stick" first.

PUSH STICK AND PUSH BLOCK

Make the Push Stick using a piece of 1 x 2, or rip one from a wide board, say 11-1/2 in. wide, and set the rip fence 9-7/8 in. from the sawblade.

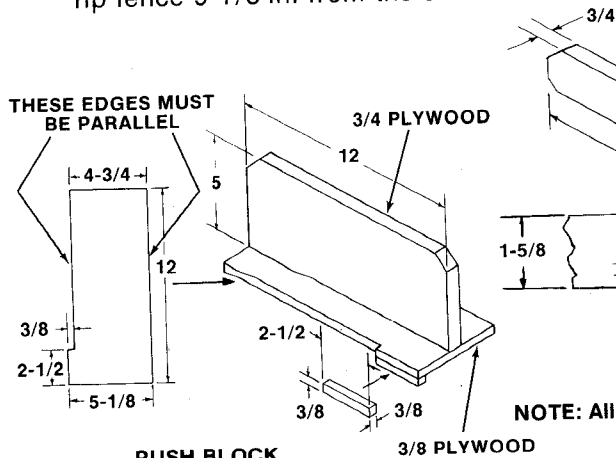

PUSH BLOCK
NOTE: All dimensions in inches

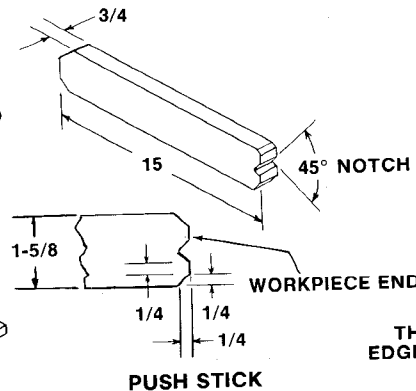

PUSH STICK
NOTE: All dimensions in inches.

Make the Push Block using a piece of 3/8 in. and 3/4 in. plywood.

The small piece of wood 3/8 in. x 3-1/2 in. should be GLUED to the plywood . . . DO NOT USE NAILS. This is to prevent dulling the sawblade in the event you mistakenly cut into the push block.

Position the handle in the center of the plywood and fasten together with glue and woodscrews.

AUXILIARY FENCE/WORK SUPPORT

Make one using a piece of 3/8 in. and 3/4 in. plywood. Fasten together with glue and woodscrews.

NOTE: Since the Push Block is used with the Auxiliary Fence, the 4-3/4 in. dimensions must be held identical on both the pieces.

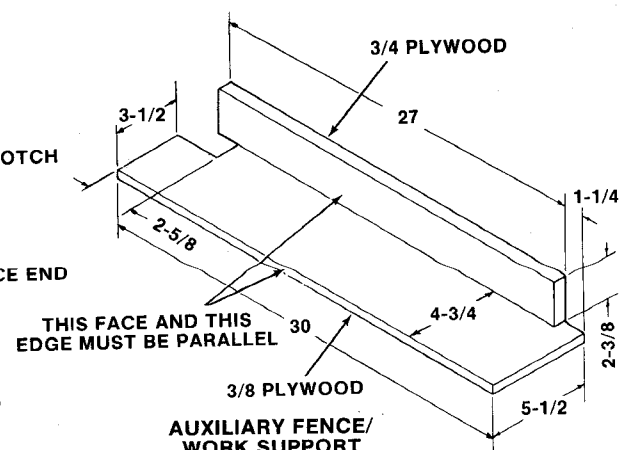

AUXILIARY FENCE/WORK SUPPORT
NOTE: All dimensions in inches

USING THE MITER GAUGE

FOR CROSSCUTTING, MITER CUTTING, BEVEL CUTTING, COMPOUND MITER CUTTING, DADOING and when RABBETTING AND MOLDING across the end of a narrow workpiece, THE MITER GAUGE IS USED.

WARNING: FOR YOUR OWN SAFETY, ALWAYS OBSERVE THE FOLLOWING SAFETY PRECAUTIONS IN ADDITION TO THE SAFETY INSTRUCTIONS ON PAGES 2, 3, and 4.

1. Never make these cuts freehand (without using the miter gauge or other auxiliary devices) because the blade could bind in the cut and cause a KICKBACK or cause your fingers or hand to slip into the blade.
2. Always lock the miter gauge securely when in use.
3. Remove rip fence from table.
4. Make sure blade guard is installed for all "thru-sawing" operations (when sawblade cuts entirely through the thickness of the workpiece.) Replace guard IMMEDIATELY after completion of dadoing, molding or rabbeting cuts.
5. Have blade extend approximately 1/8 in. above top of workpiece. Additional blade exposure would increase the hazard potential.
6. Do not stand directly in front of the blade in case of a THROWBACK (Small cut-off piece caught by the back of the blade and thrown toward the operator). Stand to either side of the blade.
7. Keep your hands clear of the blade and out of the path of the blade.
8. If blade stalls or stops while cutting, TURN SWITCH OFF before attempting to free the blade.
9. Do not reach over or behind the blade to pull the workpiece through the cut . . . to support long or heavy workpieces . . . to remove cut-off pieces of material or FOR ANY OTHER REASON.
10. Do not pick up small pieces of cut-off material from the table. REMOVE them by pushing them OFF the table with a long stick. Otherwise they could be thrown back at you by the rear of the blade.
11. Do not remove small pieces of cut-off material that may become TRAPPED inside the blade guard while the saw is RUNNING. THIS COULD ENDANGER YOUR HANDS or cause a KICKBACK.
Turn the saw OFF. After the blade has stopped turning, lift the guard and remove the piece.

CALIBRATING THE SAW FOR ELECTRONIC OPERATIONS

Whenever the saw has been unplugged or there has been an interruption in power, it will be necessary to calibrate the "zero" points for the elevation and bevel operations. To do this, perform the steps listed below.

NOTE: For calibrating the saw with a sawblade or other cutting tool that is less than 10" in diameter refer to the section headed "Calibration Procedure for Cutting Tools Less than 10" Diameter" page 30.

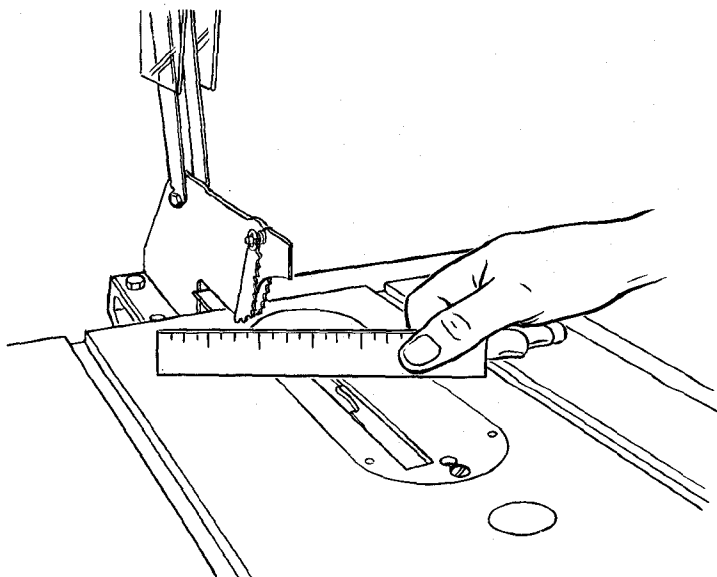
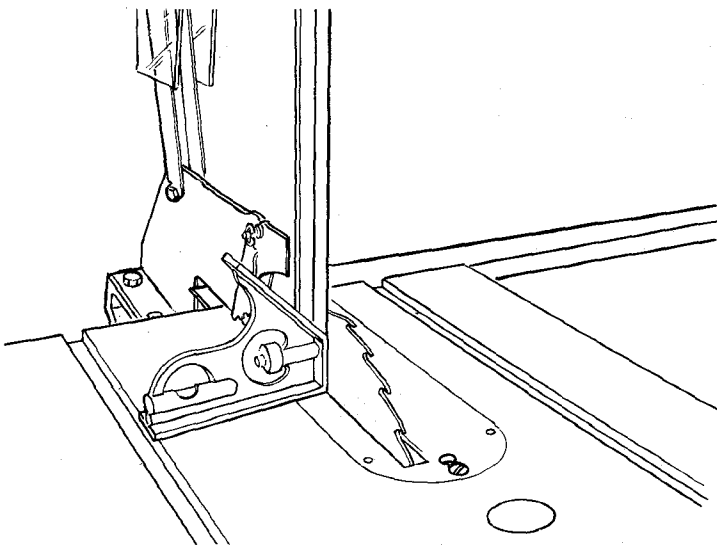
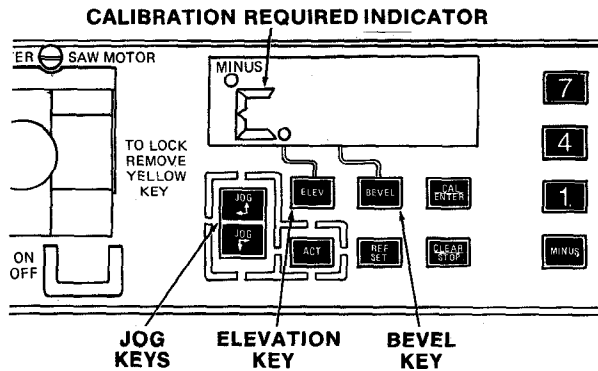

Calibration Procedure Using 10" Diameter Sawblade.

1. Plug in the saw and insert yellow key into MASTER switch and turn "ON." Display will show flashing C.
2. Press ELEV key.
3. Press and hold in the JOG key to raise blade until the maximum elevation is reached (indicated by a distinct change in pitch of the motor.) Press and hold the JOG key to just pull blade away from the stop.
4. Press BEVEL key.
5. Place a square against table top and the left side of the sawblade (be sure that the square is not resting against a saw tooth).
6. Press and release the JOG and JOG keys until blade is square to the table.
NOTE: For greater accuracy make the final adjustment into square from the right using the jog key marked JOG
7. Press the ELEV key.
8. Press and hold JOG key to lower blade until the blade is completely below the table top.
9. Repeatedly press and release the JOG key to jog blade up until the tip of a saw tooth is just even with the table top.
NOTE: Final adjustment should be made with the blade coming up to the level of the table top rather than down, for greatest accuracy.
10. Now press the CAL ENTER key. The display will read 0.000 which is zero elevation. Pressing the BEVEL key will display 0.0. The elevation and bevel operation will now be calibrated until the saw is either unplugged or there is a power interruption. When the work session is over, return the blade to the 0° bevel position and the tip of the 10" sawblade even with the table top before unplugging saw. Refer to "Shut Down Procedure to Retain Calibration." With the saw at this setting, it will only be necessary to plug the saw in, turn the MASTER switch "ON" and press the CAL ENTER key to calibrate the saw, next time it is used.

NOTE: The saw will remain calibrated even if the Master Switch is "off" and "locked", as long as the saw is plugged in and there is no power interruption.

SHUT DOWN PROCEDURE TO RETAIN CALIBRATION

By following the procedure below when the work session is over, recalibration is done by simply pressing the **CAL ENTER** key after the saw is plugged in and the MASTER switch is turned "ON".

1. Press **BEVEL** key.
2. Press **0** key.
3. Press **CAL ENTER** key.
4. Press **ELEV** key.
5. Press **0** key.
6. Press **ACT** key.

Saw blade will automatically return to the "0" bevel and "0" elevation where it was calibrated.

(Note: This operation will not work if **REF SET** key has been used and a new "zero" location set.)

7. Turn MASTER switch "OFF" and remove yellow key.

CALIBRATION OF SAW WHEN USING A CUTTING TOOL SMALLER THAN 10" DIAMETER.

When a cutting tool smaller than 10" diameter, such as a dado head or molding head, is to be used, it will be necessary to use the "calibration gauge" included with the saw to calibrate the saw after changing cutting tools.

WARNING: Unplug the saw whenever changing the cutting tool.

Keep fingers away from and out of line with the cutting tool when calibrating the saw.

Along with this manual came a plastic gauge titled "CALIBRATION GAUGE". This gauge fits over the fixed blade flange on the saw arbor (see illustration) and sticks up above the table.

A full size reproduction has been printed in this manual, on page 45.

1. After cutting tool is securely mounted, plug in saw and turn on MASTER switch. Press the **ELEV** key.

2. Place the notch of the Gauge down into the insert opening on the left side of the cutting tool. Place the notch over the fixed blade collar of the arbor.

3. Holding the Gauge by the top edge, jog the arbor down or up until the heavy line lies even with the table with the notch still firmly against the arbor flange.

4. Press the **CAL ENTER** key. This will set the "zero" point for both elevation and bevel.

NOTE: Other "zero" reference points can now be set using **REF SET** key without affecting the calibration settings as long as the power to the saw is not interrupted.

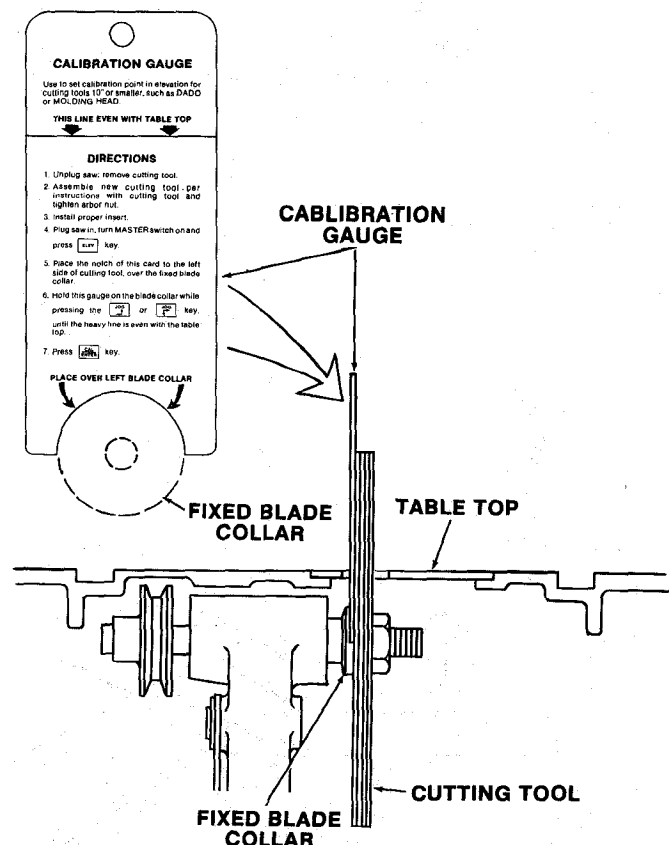

CROSSCUTTING

CROSSCUTTING is cutting wood across the grain, at 90°, or square with both the edge and the flat side of the wood. This is done with miter gauge set at "0". The graduations on the miter gauge provide accuracy for average woodworking. In some cases where extreme accuracy is required, make a trial cut and then recheck it with an accurate square, or protractor.

If necessary, the miter gauge head can be swiveled slightly to achieve the desired angle.

NOTE: The space between the miter gauge bar and the groove in the table is held to minimum during manufacturing.

For maximum accuracy when using the miter gauge, always "favor" one side of the groove in the table. In other words, don't move the miter gauge from side to side while cutting, but keep one side of the bar riding against one side of the groove.

NOTE: Glue a piece of sandpaper to the face of the miter gauge head. This will help prevent the workpiece from "creeping" while it is being cut.

The Hold-Down Clamp (Optional Accessory) should be used on the miter gauge for greater accuracy.

The miter gauge may be used in either of the grooves in the table. Make sure it is locked.

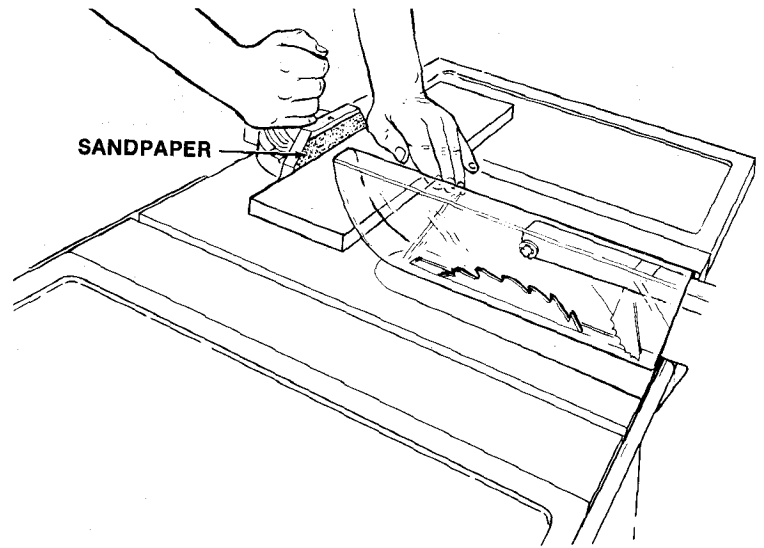

When using the miter gauge in the LEFT hand groove, hold the workpiece firmly against the miter gauge head with your left hand, and grip the lock handle with your right.

When using the RIGHT Hand groove, hold the workpiece with your right hand and the lockhandle with your left hand.

In this example a 1" x 6" board will be cut on a 90° angle to its edge.

NOTE: A 1" thick board is actually 3/4 of an inch thick.

Have saw calibrated, with tip of blade even with table top. Have guard in place.

STEP 1- Set the miter gauge to the zero position.

STEP 2- Turn MASTER switch on and press **ELEV**

key. Press number keys **7** **5** (the decimal equivalent of 7/8 inches). Press **ACT** key. The blade will automatically raise to the programmed height. Blade elevation will be displayed.

STEP 3- Draw a line on the board at the cut-off point — long enough for sighting, position the board against the miter gauge face. Align cut-off point with Exact-I-Cut indicator.

STEP 4- Firmly hold the board in this position. (A hold down clamp is recommended for greater accuracy). Turn on the saw motor.

STEP 5 Guide the board through the blade.

STEP 6 Turn the motor "OFF". Wait for the blade to stop before removing the boards and returning the miter gauge to the starting position.

STEP 7- Press **ELEV** key. Press number key **0** . Press **ACT** . The blade will lower automatically until it is even with the table.

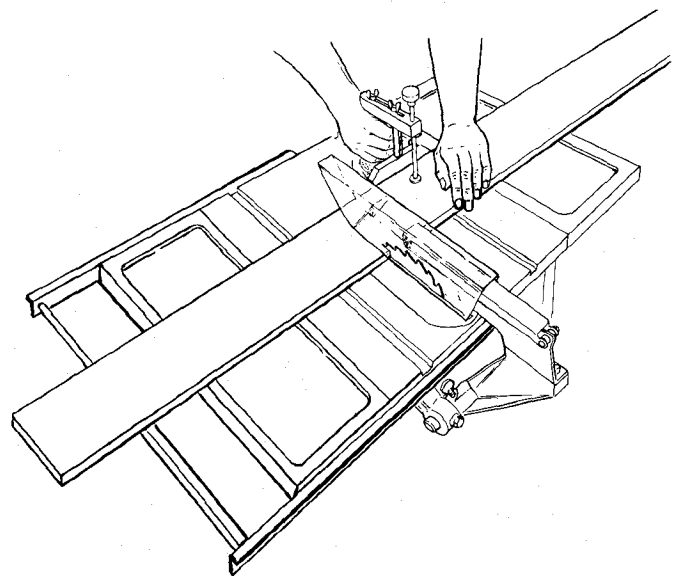
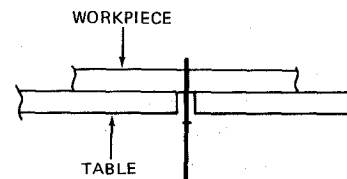

When cutting long workpieces, invert AUXILIARY FENCE/WORK SUPPORT and position it on top of the guide bars to support the workpiece as near to the end as possible. If this does not adequately support the workpiece, you can make a simple support by clamping a piece of plywood to a sawhorse.

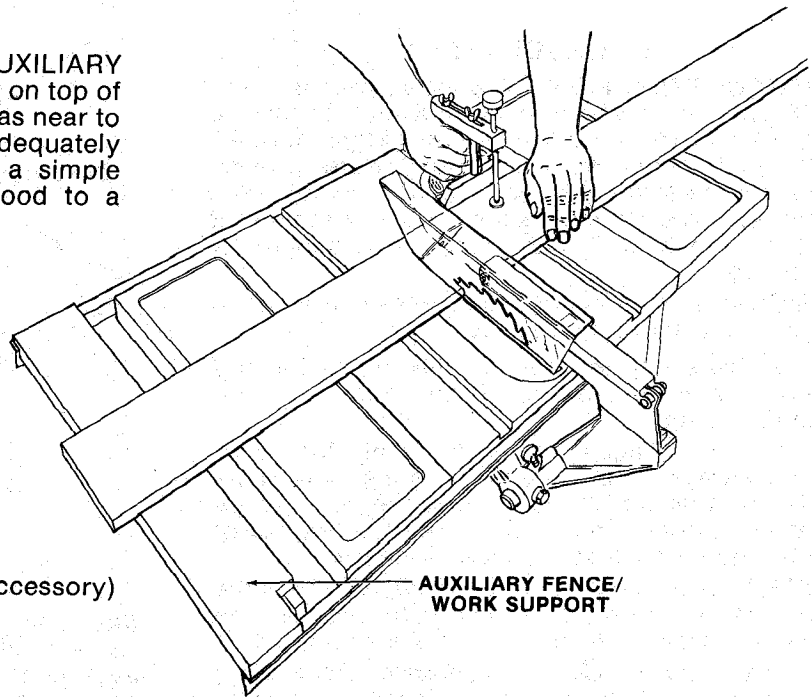

Use the Hold-Down Clamp (Optional Accessory) on the miter gauge for greater accuracy.

REPETITIVE CUTTING

REPETITIVE CUTTING is cutting a quantity of pieces the same length without having to mark each piece.

1. Use the Stop Rods (optional accessory) only for cutting duplicate pieces 6 in. long and longer.
2. DO NOT FEED workpiece with RIGHT HAND, merely guide it, making sure that it does not bind or pinch the sawblade.

When making repetitive cuts from a long workpiece, make sure it is adequately supported.

Use the Hold-Down Clamp (Optional Accessory) on the miter gauge for greater accuracy.

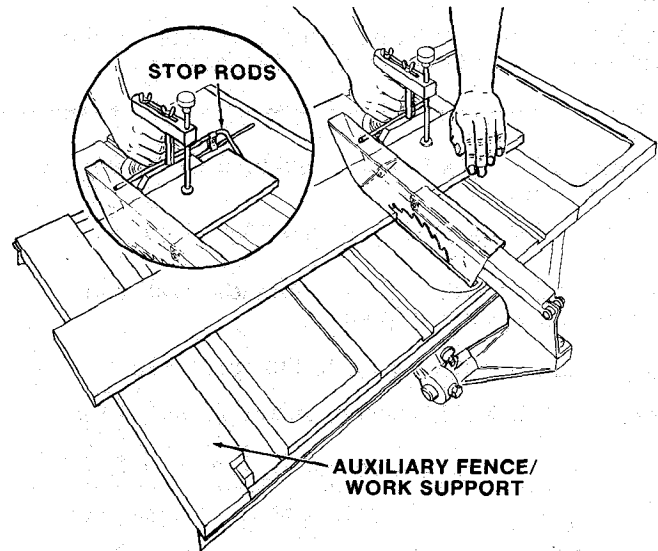

1. NEVER USE THE RIP FENCE AS A LENGTH STOP BECAUSE THE CUTOFF PIECE COULD BIND BETWEEN THE FENCE AND THE BLADE CAUSING A KICKBACK.

2. When making repetitive cuts shorter than 6 in., clamp a block of wood 2 in. long to the table to act as a length stop. Do not clamp directly to the bottom edge of the table because the "swivel" of the clamp will not grip properly. Place a small block of wood between the bottom edge of the table and the "C" clamp.

CAUTION: When clamping the block, make sure that the end of the block is well in front of the sawblade. Be sure it is clamped securely.

3. Slide the workpiece along the miter gauge until it touches the block . . . hold it securely or clamp it with the Hold-Down Clamp (Optional Accessory).

4. Make the cut . . . pull the workpiece back . . . push the cut off piece off the table with a long push stick . . . DO NOT ATTEMPT TO PICK IT UP AS THIS COULD ENDANGER YOUR HANDS.

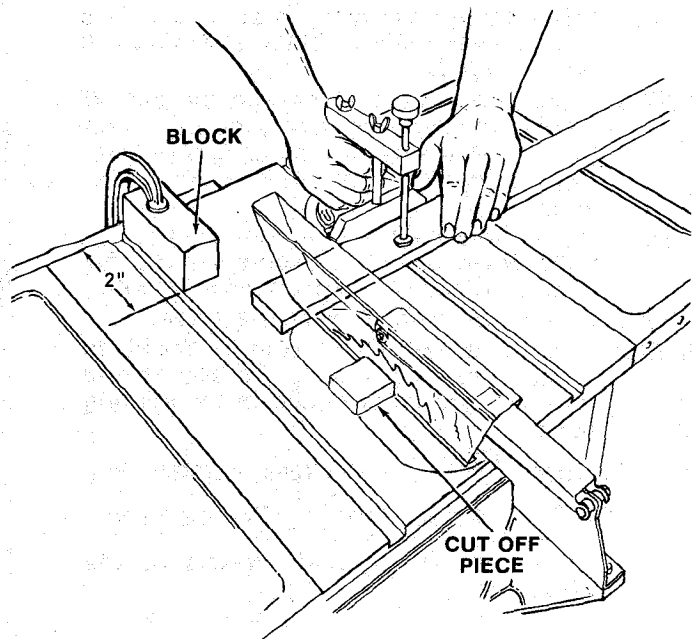

MITER CUTTING

MITER CUTTING is cutting wood at an angle other than 90° with the edge of the wood. Follow the same procedure as you would for crosscutting.

Adjust the miter gauge to the desired angle, and lock it.

The miter gauge may be used in either of the grooves in the table.

When using the miter gauge in the LEFT Hand groove, hold the workpiece firmly against the miter gauge head with your left hand, and grip the lock knob with your right.

When using the RIGHT hand groove, hold the workpiece with your right hand and the knob with your left hand.

Use the Hold-Down Clamp (Optional Accessory) in the miter gauge for greater accuracy.

In this example a 1" x 6" board will be cut on a 30° miter angle.

Have saw calibrated with tip of blade even with table top. Have guard in place.

STEP 1- Set the miter gauge to 30°. Mark the start of the cut on the board.

STEP 2- Turn on MASTER switch and press

key. Press number keys

(the decimal equivalent to 7/8 inches). Press button. The

blade will automatically raise to the correct height. Blade elevation will be displayed.

STEP 3- Position the board against the miter gauge face. Align cut mark with Exact-I-Cut indicator.

STEP 4- Firmly hold the board in this position. (A hold down clamp is recommended for greater accuracy.) Turn on the saw motor.

STEP 5- Guide the board through the blade.

STEP 6- Turn the motor "OFF". Wait for the blade to stop before removing the boards and returning the miter gauge to the starting position.

STEP 7- Press key. Press number key

. Press key. The blade will

lower automatically until it is even with the table.

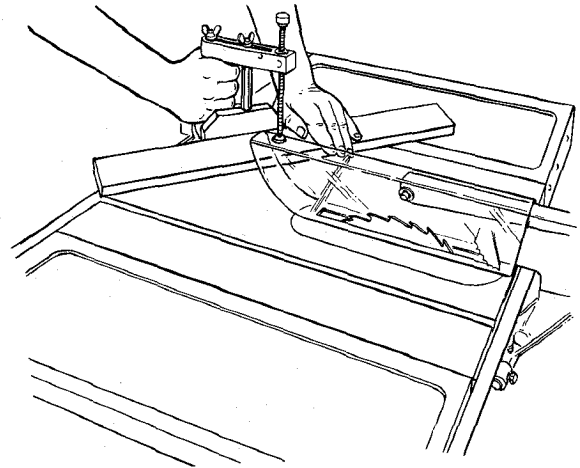
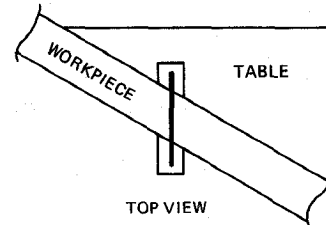

BEVEL CROSSCUTTING

BEVEL CROSSCUTTING is the same as crosscutting except that the wood is cut at an angle other than 90° with the flat side of the wood.

Adjust the blade to the desired angle.

Set blade elevation to clear top of workpiece by 1/8". Verify this clearance by placing the work next to the blade.

Use the Miter Gauge in the groove to the RIGHT of the blade. It cannot be used in the groove to the LEFT because the blade guard will interfere. Hold the workpiece with your right hand and the lockhandle with your left.

Use the AUXILIARY FENCE/WORK SUPPORT for additional support of long workpieces.

Lay it across the guide bars to support the workpiece as near to the end as possible.

Use the Hold-Down Clamp (Optional Accessory) on the miter gauge for greater accuracy.

In this example a 1" x 6" board will be cut on a 30° bevel angle.

Have saw calibrated with tip of blade even with table top. Have guard in place.

STEP 1- Turn MASTER switch on and press **BEVEL**

key. Press number keys **3** **0**.

Press **CAL** key. Press **ELEV** key. Press

number keys, **1** **.** **2**

5 (the decimal equivalent of 1-1/4 inches). Press **ACT** key. The blade will automatically raise and tilt to the correct angle.

STEP 2- Set the miter gauge to the zero position.

STEP 3- Draw a line to the board at the cut-off point — long enough for sighting. Use the miter gauge in the right side groove. Position the board against the miter gauge face. Align the cut-off point with the Exact-I-Cut indicator.

STEP 4- Firmly hold the board in this position. Turn "ON" the saw motor.

STEP 5- Guide the board through the blade.

STEP 6- Turn the motor "OFF". Wait for the blade to stop before removing the boards and returning the miter gauge to the starting position.

STEP 7- Press **BEVEL**. Press number key **0**.

Press **CAL** key. Press **ELEV** key. Press

number key **0**. Press **ACT** key. The

blade will lower automatically until it is even with the table and return to 0° bevel.

NOTE: If saw blade is tilted more than 45° from vertical, the electronic function must be recalibrated. See page 29.

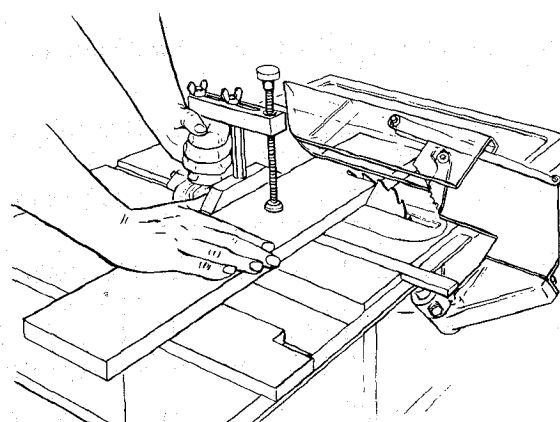
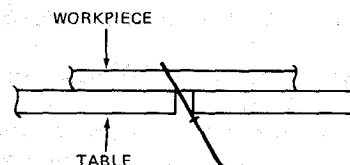

COMPOUND MITER CUTTING

COMPOUND MITER CUTTING, is a combination of miter cutting and bevel crosscutting. The cut is made at an angle other than 90° to both the edge and the flat side of the wood.

Adjust the miter gauge and the blade to the desired angle . . . Make sure miter gauge is locked.

USING THE RIP FENCE

RIPPING, BEVEL RIPPING, PLOUGHING, MOLDING, RESAWING AND RABBETING are performed using the RIP FENCE together with the AUXILIARY FENCE/WORK SUPPORT, PUSH STICK OR PUSH BLOCK.

WARNING: FOR YOUR OWN SAFETY, ALWAYS OBSERVE THE FOLLOWING SAFETY PRECAUTIONS IN ADDITION TO THE SAFETY INSTRUCTIONS ON PAGES 2, 3, and 4.

1. Never make these cuts FREEHAND (without using the rip fence or auxiliary devices when required) because the blade could bind in the cut and cause a KICKBACK.
2. Always lock the rip fence securely when in use.
3. Remove miter gauge from table.
4. Make sure blade guard is installed for all thru-sawing type cuts. Replace the guard IMMEDIATELY following completion of resawing, rabbeting, dadoing, or molding operations.

Frequently check the action of the ANTIKICKBACK PAWLS by passing the workpiece alongside of the spreader while saw is OFF.

Pull the workpiece TOWARD you. If the PAWLS do not DIG into the workpiece and HOLD it . . . the pawls must be SHARPENED. See "Maintenance" section.

5. Have blade extend approximately 1/8 in. above top of workpiece. Additional blade exposure would increase the hazard potential.
6. Do not stand directly in front of the blade in case of a KICKBACK. Stand to either side of the blade.
7. Keep your hands clear of the blade and out of the path of the blade.
8. If the blade stalls or stops while cutting, TURN SWITCH OFF before attempting to free the workpiece.
9. Do not reach over or behind the blade to pull the workpiece through the cut . . . to support long or heavy workpieces . . . to remove small cut-off pieces of material or FOR ANY OTHER REASON.
10. Do not pick up small pieces of cut-off material from the table. REMOVE them by pushing them OFF the table with a long stick. Otherwise they could be thrown back at you by the rear of the blade.
11. Do not remove small pieces of cut-off material that may become TRAPPED inside the blade guard while the saw is RUNNING. THIS COULD ENDANGER YOUR HANDS or cause a THROWBACK.
Turn the saw OFF. After the blade has stopped turning, lift the guard and remove the piece.

RIPPING

RIPPING is cutting a piece of wood with the grain, or lengthwise. This is done using the rip fence as a guide.

Position the fence to the desired WIDTH OF RIP and lock in place.

Before starting to rip, be sure:

- A. Rip Fence is parallel to sawblade.
- B. Spreader is properly aligned with sawblade.
- C. Antikickback pawls are functioning properly.

When ripping LONG BOARDS or LARGE PANELS, always use a work support.

A simple one can be made by clamping a piece of plywood to a sawhorse.

BEVEL RIPPING

When bevel ripping material 6 in. or narrower, use fence on the right side of the blade ONLY. This will provide more space between the fence and the sawblade for use of a push stick. If the fence is mounted to the left, the sawblade guard may interfere with proper use of a push stick.

ALWAYS SUPPORT LONG WORKPIECES

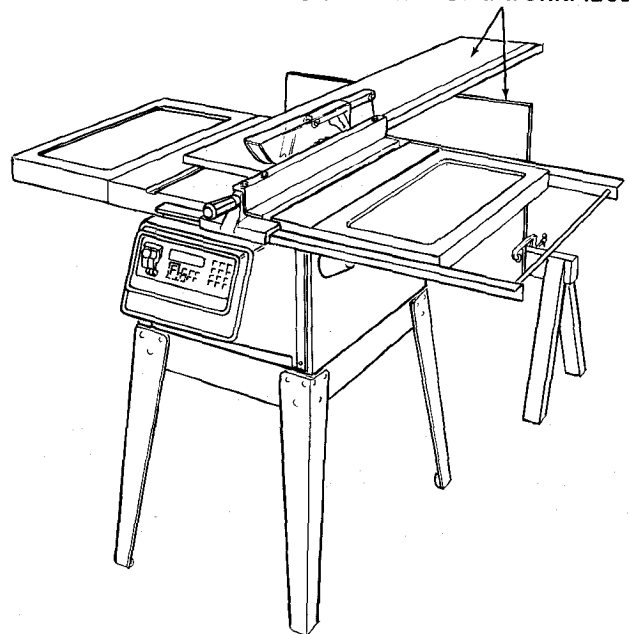

When "WIDTH OF RIP" is 6 in. and WIDER use your RIGHT Hand to feed the workpiece until it is clear of the table.

Use LEFT hand ONLY to guide the workpiece . . . do not FEED the workpiece with the left hand.

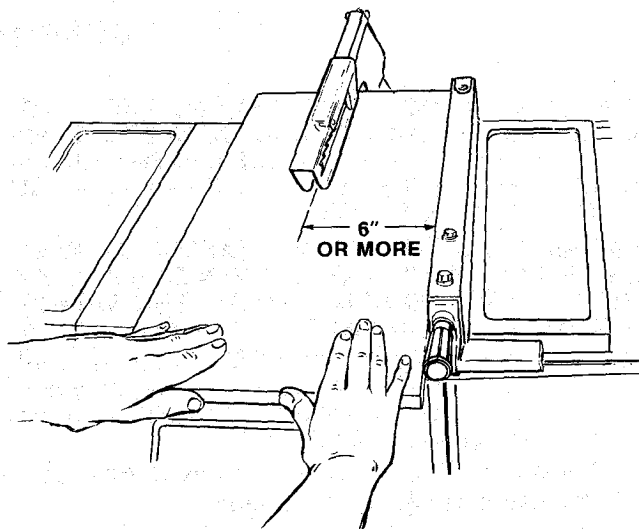

When "WIDTH OF RIP" is 2 in. to 6 in. wide USE THE PUSH STICK to feed the work.

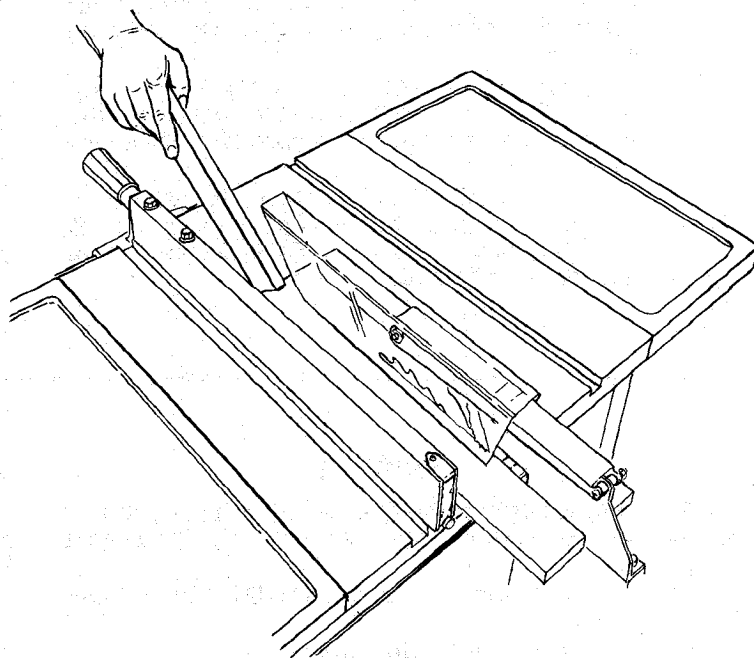

When WIDTH OF RIP is NARROWER than 2 in., the push stick CANNOT be used because the guard will interfere . . . USE the AUXILIARY FENCE/WORK SUPPORT and PUSH BLOCK.

Attach Auxiliary Fence/Work Support to rip fence with two "C" clamps.

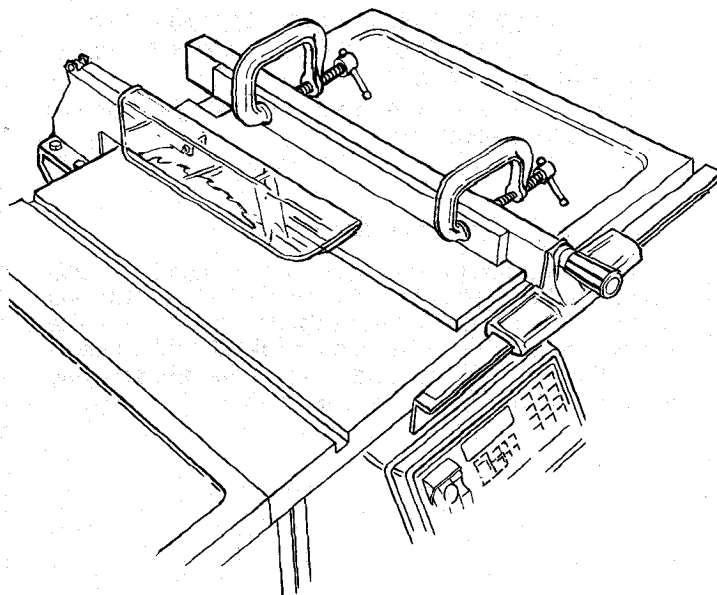

Feed the workpiece by hand along the AUXILIARY FENCE until the end is approx. 1 in. past the front edge of the table. Continue to feed using the PUSH BLOCK.

Hold the workpiece in position and install the PUSH BLOCK by sliding it on top of the AUXILIARY FENCE/WORK SUPPORT (This May Raise Guard).

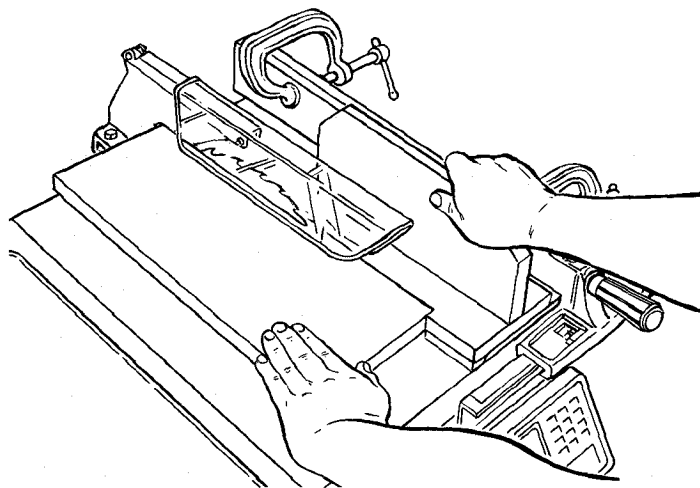

Narrow strips thicker than the Auxiliary Fence/Work Support may enter the guard and strike the baffle. CAREFULLY raise guard only enough to clear the workpiece. Use PUSH BLOCK to complete cut.

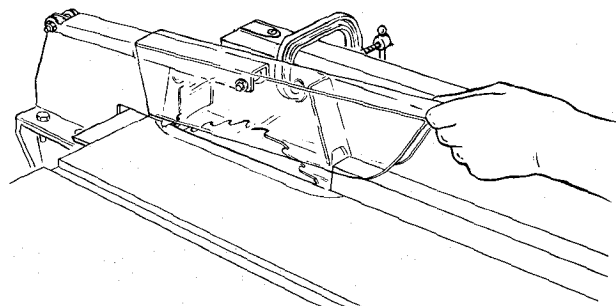
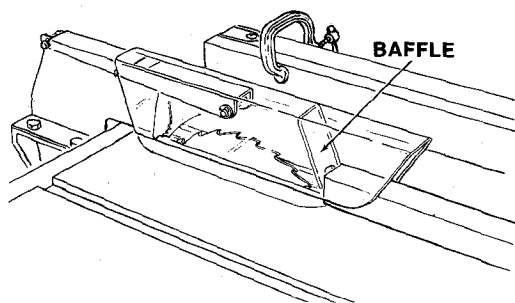

In this example a 14" wide board will be cut down the center.

Have saw calibrated. Have guard in position.

STEP 1- Position the board so the usable piece will be 7 inches between the blade and the fence.

STEP 2- Adjust the fence against the board so it is parallel to the saw blade. Lock the fence in position.

STEP 3- Turn MASTER switch "ON" and press

key. Press number keys

(decimal equivalent of 7/8

inches.) Press key. The blade will automatically raise to the programmed height. Blade elevation will be displayed.

STEP 4- Firmly hold the board in cutting position. Turn on the saw motor.

STEP 5- Guide the board through the blade. Pushing only on the piece between blade and the fence.

STEP 6- Turn the motor "OFF". Wait for the blade to stop before removing the boards.

STEP 7- Press key. Press number key

. Press key. The blade will

lower automatically until it is even with the table.

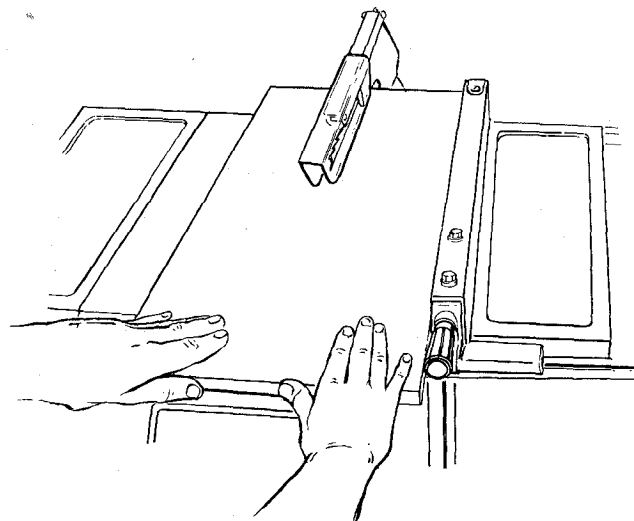
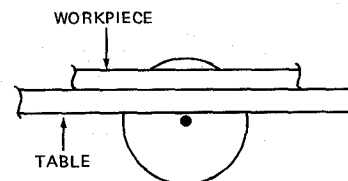

PLOUGHING AND MOLDING

PLOUGHING is grooving with the grain the long way of the workpiece, using the fence. Use proper holddowns and feed devices.

MOLDING is shaping the workpiece with the grain the long way of the workpiece, using the fence. Use proper holddowns and feed devices.

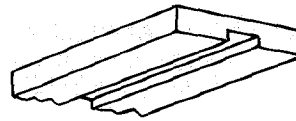

PLOUGHING

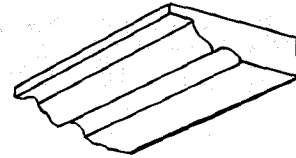

SURFACE MOLDING

RESAWING

RESAWING is known as ripping a piece of wood through its thickness. Do not attempt to resaw BOWED or WARPED material. NOTE: To RESAW a piece of wood wider than 3-3/8 in. . . it will be necessary to remove the blade guard . . . and use the AUXILIARY FENCE/WORK SUPPORT. (See "Work Helpers").

Clamp it to the table so that the workpiece will SLIDE EASILY, but not TILT or MOVE SIDEWAYS, without BINDING between the two fences.

Do not clamp directly to the bottom edge of the table because the "swivel" of the clamp will not grip properly. Place a small block of wood between the bottom edge of the table and the "C" clamp.

WARNING: FOR YOUR OWN SAFETY . . .

1. DO NOT "BACK-UP" (REVERSE FEEDING) WHILE RESAWING BECAUSE THIS COULD CAUSE A KICKBACK.
2. MAKE FIRST PASS TO A DEPTH SLIGHTLY LESS THAN ONE-HALF THE WIDTH OF THE BOARD; KEEP SAME FACE OF BOARD AGAINST FENCE FOR SECOND PASS AS THE FIRST PASS.
3. INSTALL BLADE GUARD IMMEDIATELY UPON COMPLETION OF THE RESAWING OPERATION.

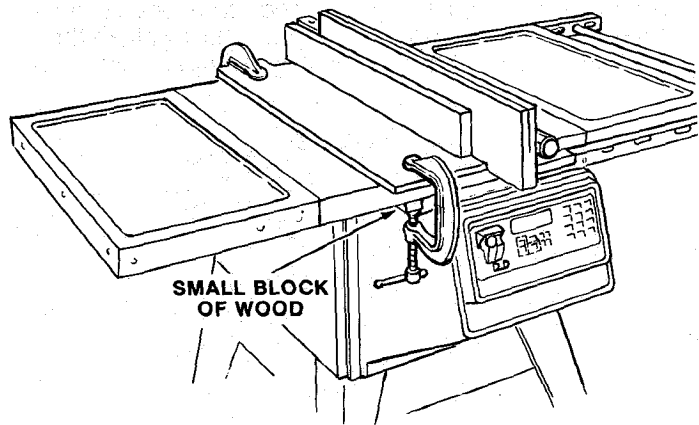

CUTTING PANELS

When cutting panels (whenever fence is positioned outside of table surface), ALWAYS use the AUXILIARY FENCE/WORK SUPPORT.

1. Unlock fence and raise rear end.
2. Position AUXILIARY FENCE/WORK SUPPORT as shown and attach it with two "C" clamps.

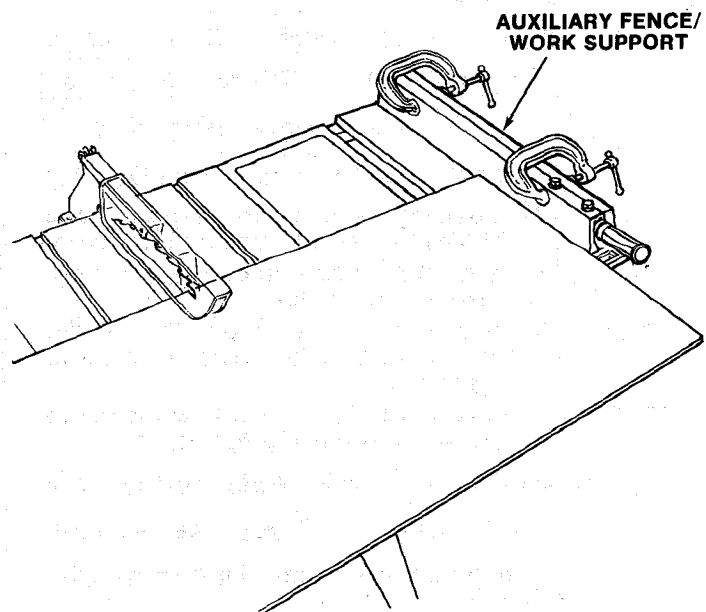

RABBETING

RABBETING is known as cutting out a section of the corner of a piece of material, across an end or along an edge.

To make a RABBET requires cuts which do not go all the way through the material. Therefore the blade guard must be removed.

1. Remove blade guard.

For rabbeting along an edge (long way of workpiece) as shown, add facing to rip fence (see 6, RIP FENCE, p. 25) approximately as high as the workpiece is wide. Adjust rip fence and blade to required dimensions; then make first cut with board flat on table as any rip (type) cut; make second cut with workpiece on edge. Follow all precautions, safety instructions, and operational instructions as for ripping, or rip type operations, including feather boards and push stick, etc.

3. For rabbeting across an end, for workpiece 10-1/2" and narrower make the rabbet cut with the board flat on the table using the miter gauge fitted with a facing (per "7, MITER GAUGE p. 25) DO NOT use the rip fence.

4. **INSTALL BLADE GUARD IMMEDIATELY UPON COMPLETION OF RABBETING OPERATION.**

Rabbet cuts can also be made using the dado head or molding head.

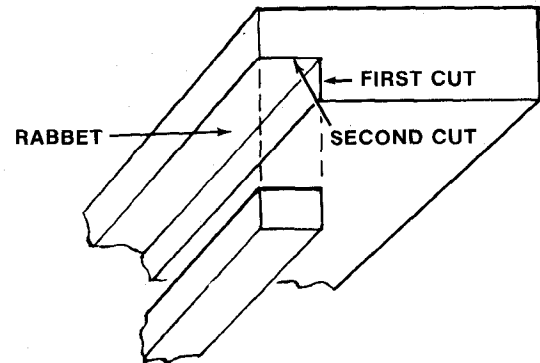

DADOING

Instructions for operating the Dado Head are contained in a booklet furnished with the Dado Head.

The Recommended Dado Head is listed under Recommended Accessories in this manual.

The arbor on the saw, is only long enough so that the widest cut that can be made is 13/16" wide.

It is not necessary to install the outside loose collar before screwing on the arbor nut. Make sure the arbor nut is tight.

ALWAYS USE DADO INSERT LISTED UNDER RECOMMENDED ACCESSORIES.

When using the dado head it will be necessary to remove the Blade Guard and Spreader. **USE CAUTION. USE FEATHERBOARDS AND PUSH STICKS AS REQUIRED.**

ALWAYS REPLACE THE BLADE, GUARD AND SPREADER WHEN YOU ARE FINISHED DADOING.

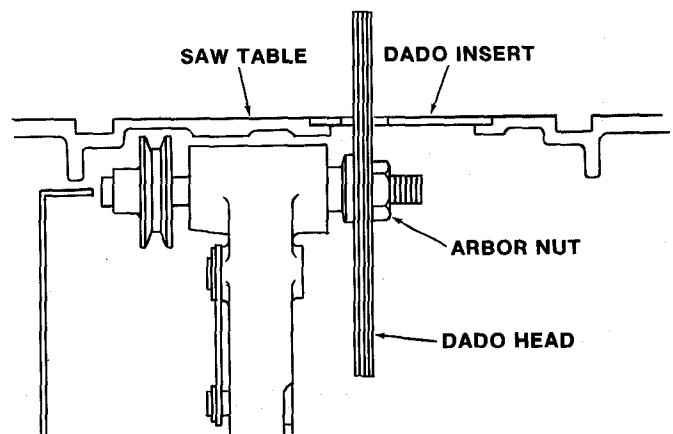

MOLDING CUTTING

Instructions for operating the Molding Head are contained in a booklet furnished with the Molding Head.

The recommended molding head is listed under "Recommended Accessories" in this manual.

Always use Molding Insert Listed Under "Recommended Accessories."

When using the molding head it will be necessary to remove the Blade Guard and Spreader. **USE CAUTION. USE FEATHERBOARDS AND PUSH STICKS, etc. AS REQUIRED.**

ALWAYS REPLACE THE BLADE GUARD AND SPREADER WHEN YOU ARE FINISHED MOLDING.

USING FEATHERBOARDS

Add 8 inch high flat facing board to the fence, the full length of the fence.

Use featherboards for all non "thru-sawing" operations (when sawblade guard must be removed). Featherboards are used to keep the work in contact with the fence and the table as shown, and to stop kickbacks.

Mount featherboards to fence and table as shown, so that leading edges of featherboards will support workpiece until cut is complete, and the workpiece has been pushed completely past the cutter

(sawblade, dado head, molding head, etc.) with a pushstick, as in ripping.

Before starting the operation (switch 'OFF' and cutter below table surface):

- (a) Install featherboards so they exert pressure on the workpiece; be positive they are secure, and
- (b) Make sure by trial that the featherboards will stop a kickback if one should occur.

Featherboards are not employed during non thru-sawing operations when using the miter gauge.

Replace the sawblade guard as soon as the non thru-sawing operation is complete.

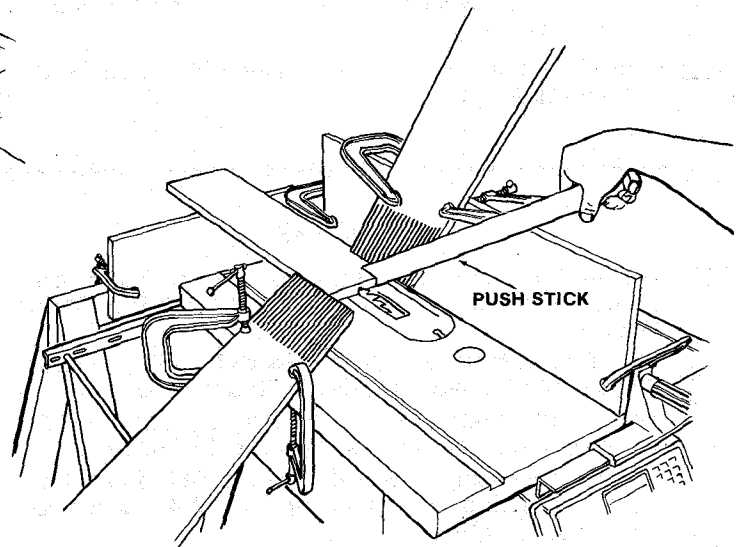
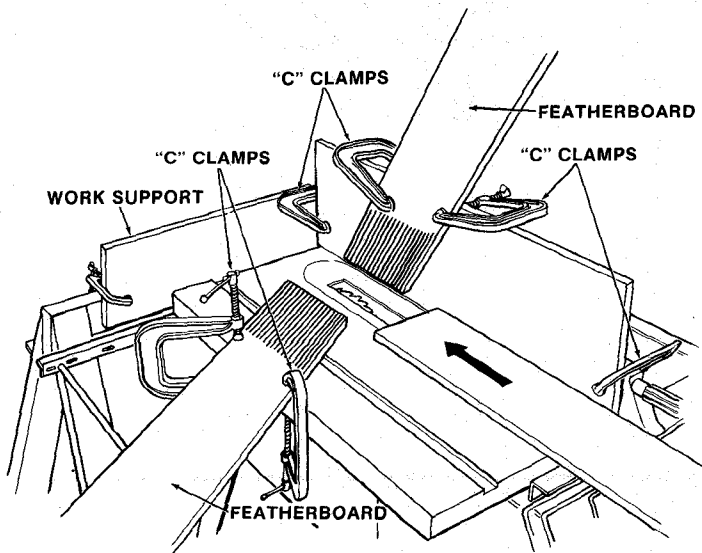

RECOMMENDED ACCESSORIES

ITEM	CAT. NO.
Steel Legs	9-22235
Steel Stand	9-22214
Caster Sets	9-22222 or 9-22221
Solid Table Extension	9-29957
7 in. Molding Head Set	9-3217
7 in. Molding Head Set	9-3218
7 in. Molding Head	9-3214
Molding/Dado Insert for 7 in.	
Dia. Molding or Dado Head	9-29997
Work Light	9-2480
Work Light	9-2481
7 in. Dia. Adjustable Dado Head	
9-3261 — 9-3262 — 9-3263	

ITEM	CAT. NO.
7 in. Dia. Dado Head	9-3257
Sanding Wheel	9-22723
Miter-Gauge Stop Rods	9-29924
Miter-Gauge Hold-Down Clamp	9-29928
Taper Jig	9-3233
Universal Jig	9-3235
Power Tool Know How Handbook	
Table Saw	9-2918
Sawdust Collector	9-29966
Rip Fence Bar	9-29969
Table Extension	9-29968
10" Dia. Sawblades with 5/8 bore ...	see Catalog

MAINTENANCE

WARNING: FOR YOUR OWN SAFETY, TURN SWITCH "OFF" AND REMOVE PLUG FROM POWER SOURCE OUTLET BEFORE MAINTAINING OR LUBRICATING YOUR SAW.

Do not allow sawdust to accumulate inside the saw. Frequently blow out any dust that may accumulate inside the saw cabinet and the motor.

Frequently clean you cutting tools with Craftsman Gum and Pitch Remover.

A coat of automobile-type wax applied to the table will help to keep the surface clean and allow workpieces to slide more freely.

If the power cord or motor cord is worn or cut, or damaged in any way, have it replaced immediately.

Make sure the teeth of the ANTIKICKBACK pawls are always sharp. To sharpen:

1. Remove blade guard.
2. Rotate pawl toward rear of spreader so that teeth are above top of spreader.
3. Hold spreader with left hand and place pawl over corner of workbench.
4. Using a small round file (Smooth Cut) sharpen the teeth.

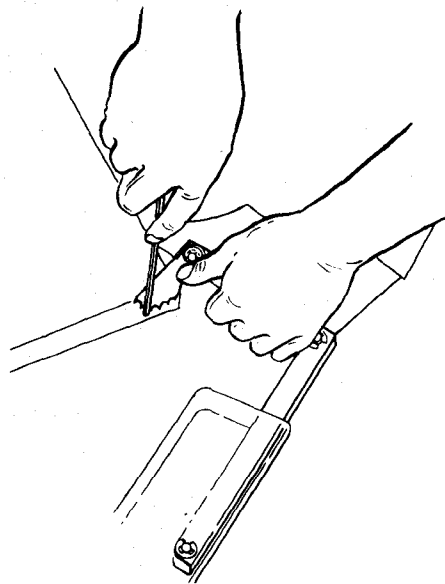

LUBRICATION

The following parts should be oiled occasionally with SAE No. 20 or No. 30 engine oil.

1. Tilt screw threads and pivot nut. (First Clean with Craftsman Gum & Pitch Remover.)
2. Elevation screw threads and pivot nut. (First Clean with Craftsman Gum & Pitch Remover.)
3. Cradle bearing points.
4. Bearing points in guard assembly, miter gauge and rip fence.

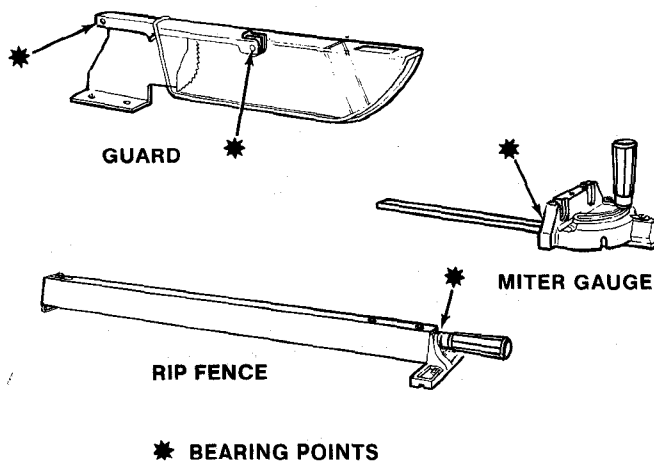
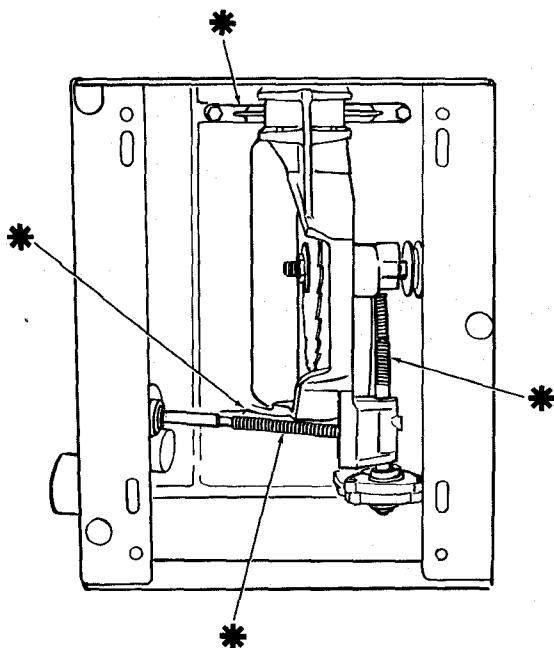

TROUBLE SHOOTING

WARNING: FOR YOUR OWN SAFETY, TURN SWITCH "OFF" AND ALWAYS REMOVE PLUG FROM POWER SOURCE OUTLET BEFORE TROUBLE SHOOTING.

TROUBLE SHOOTING — GENERAL

TROUBLE	PROBABLE CAUSE	REMEDY
Excessive vibration.	<ol style="list-style-type: none"> 1. Blade out of balance. 2. Damaged V-Belt Pulleys or poor belt. 	<ol style="list-style-type: none"> 1. Discard Blade and use a different blade. 2. Replace as Indicated.
Cannot make square cut when crosscutting.	<ol style="list-style-type: none"> 1. Miter gauge not adjusted properly. 	<ol style="list-style-type: none"> 1. See "Assembly" section "Miter Gauge."
Cut binds, burns or stalls motor when ripping.	<ol style="list-style-type: none"> 1. Dull blade with improper tooth set. 2. Blade is Heeling. 3. Warped board 4. Rip fence not parallel to blade. 5. Spreader out of alignment 	<ol style="list-style-type: none"> 1. Sharpen or replace blade. 2. See "Assembly" section, "Heeling Adjustment..." 3. Make sure concave or hollow side is facing "down," feed slowly. 4. See "Assembly" section, "Aligning Rip Fence" 5. See "Assembly" section, "Installing Blade Guard."
Cut not true at 90° or 45° positions.	<ol style="list-style-type: none"> 1. Not calibrated. 	<ol style="list-style-type: none"> 1. See "Calibrating the Electronic Function"
Tilt and elevating noisy or slow.	<ol style="list-style-type: none"> 1. Sawdust on threads of tilt screw or elevating screw. 	<ol style="list-style-type: none"> 1. See "Maintenance and Lubrication" section.

TROUBLE SHOOTING — SAW MOTOR



NOTE: Motors used on wood-working tools are particularly susceptible to the accumulation of sawdust and wood chips and should be blown out or "vacuumed" frequently to prevent interference with normal motor ventilation.

TROUBLE	PROBABLE CAUSE	REMEDY
Excessive noise.	<ol style="list-style-type: none"> 1. Motor. 	<ol style="list-style-type: none"> 1. Have motor checked by qualified service technician. Repair service is available at your nearest Sears store.
Motor fails to develop full power. NOTE: LOW VOLTAGE: (Power output of motor decreases rapidly with decrease in voltage at motor terminals. For example, a reduction of 10% in voltage causes a reduction of 19% in maximum power output of which the motor is capable, and a reduction of 20% in voltage causes a reduction of 36% in maximum power output.)	<ol style="list-style-type: none"> 1. Circuit overloaded with lights, appliances and other motors. 2. Undersize wires or circuit too long. 3. General overloading of power company facilities. 	<ol style="list-style-type: none"> 1. Do not use other appliances or motors on same circuit when using the saw. 2. Increase wire sizes, or reduce length of wiring. See "Motor Specifications and Electrical Requirements" section. 3. Request a voltage check from the power company.

TROUBLE SHOOTING — SAW MOTOR (Continued)

TROUBLE	PROBABLE CAUSE	REMEDY
Motor starts slowly or fails to come up to full speed.	<ol style="list-style-type: none"> 1. Low voltage will not trip relay. 2. Windings burned out or open. 3. Sawdust inside motor. 	<ol style="list-style-type: none"> 1. Request voltage check from the power company. 2. Have motor repaired or replaced. 3. Blow or vacuum sawdust from motor.
Motor overheats.	<ol style="list-style-type: none"> 1. Motor overloaded. 2. Improper cooling. (Air circulation restricted through motor due to sawdust, accumulating inside of saw). 	<ol style="list-style-type: none"> 1. Feed work slower into blade. 2. Clean out sawdust to provide normal air circulation through motor. See "Maintenance and Lubrication" section.
Starting switch in motor will not operate.	<ol style="list-style-type: none"> 1. Burned switch contacts (due to extended hold-in periods caused by low line voltage, etc.) 2. Shorted capacitor 3. Loose or broken connections. 	<ol style="list-style-type: none"> 1. Have switch replaced and request a voltage check from the power company. 2. Have capacitor tested and replace if defective. 3. Have wiring checked and repaired.
Motor stalls (resulting in blown fuses or tripped circuit breakers).	<ol style="list-style-type: none"> 1. Starting switch not operating. 2. Voltage too low to permit motor to reach operating speed. 3. Fuses or circuit breakers do not have sufficient capacity. 	<ol style="list-style-type: none"> 1. Have switch replaced. 2. Request voltage check from the power company. 3. Install proper size fuses or circuit breakers.
Frequent opening of fuses or circuit breakers.	<ol style="list-style-type: none"> 1. Motor overloaded. 2. Fuses or circuit breakers do not have sufficient capacity. 3. Starting switch not operating (motor does not reach speed). 	<ol style="list-style-type: none"> 1. Feed work slower into blade. 2. Install proper size fuses or circuit breakers. 3. Have switch replaced.

TROUBLE SHOOTING — ELECTRONICS

TROUBLE	CAUSE	REMEDY
Flashing "C" in display when Master Switch is turned "ON".	<ol style="list-style-type: none"> 1. Power Interruption 2. Saw just plugged in and not calibrated 	<ol style="list-style-type: none"> 1. See "Calibrating The Saw For Electronic Operations" p. 29.
No display or failure of electronic function	<ol style="list-style-type: none"> 1. No power to unit. 2. Master Switch "OFF". 3. Electronics failure 	<ol style="list-style-type: none"> 1. Check plug, fuse, or circuit breakers. Inspect line, cord and plug for damaged insulation and shorted wires. 2. Turn Master Switch "ON". 3. Have electronics checked by qualified service technician, repair service is available at your nearest Sears store.
Steady "C" in display.	<ol style="list-style-type: none"> 1. A function key has been pressed but saw has not been calibrated. 	<ol style="list-style-type: none"> 1. See "Calibrating The Saw For Electronic Operations" p. 29.
Flashing display. Elevation or bevel motor tries to run but stops.	<ol style="list-style-type: none"> 1. Elevation or bevel positioning motor jammed against stop. 	<ol style="list-style-type: none"> 1. Press Jog keys to pull away from stop.
 key does not function.	<ol style="list-style-type: none"> 1. No elevation or bevel keyed in or saw is already at desired elevation or bevel. 2. Elevation greater than plus or minus 4.095 inches. 	<ol style="list-style-type: none"> 1. Key in correct elevation or bevel. 2. Press  key and key in correct elevation.
Elevation motor runs slow or noisily	<ol style="list-style-type: none"> 1. Elevation screw threads filled with pitch & sawdust. 	<ol style="list-style-type: none"> 1. Clean threads & lubricate
Bevel motor runs slow or is noisy.	<ol style="list-style-type: none"> 1. Tilt Screw threads filled with pitch & sawdust. 	<ol style="list-style-type: none"> 1. Clean threads & lubricate
Elevation or bevel motor stops before reaching target number or will not run. Saw is not jammed.	<ol style="list-style-type: none"> 1. Positioning motor overheated. 	<ol style="list-style-type: none"> 1. Allow to cool for at least 10 minutes.
Depth of cut or blade angle incorrect.	<ol style="list-style-type: none"> 1. Saw not properly calibrated. 	<ol style="list-style-type: none"> 1. See "Calibrating The Saw For Electronic Operations" p. 29
Display does not respond correctly to keys.	<ol style="list-style-type: none"> 1. Static Electricity 	<ol style="list-style-type: none"> 1. Turn master switch "OFF" then "ON". If still not right unplug saw from power supply momentarily. Recalibrate saw p. 29.

If you require further help on operating your new Craftsman Electronic Table Saw call 800-325-1184. In Missouri call 314-595-2500.







CALIBRATION GAUGE

Use to set calibration point in elevation for cutting tools 10" or smaller, such as DADO or MOLDING HEAD.

THIS LINE EVEN WITH TABLE TOP



DIRECTIONS

1. Unplug saw; remove cutting tool.
2. Assemble new cutting tool per instructions with cutting tool and tighten arbor nut.
3. Install proper insert.
4. Plug saw in, turn MASTER switch on and press  key.
5. Place the notch of this card to the left side of cutting tool, over the fixed blade collar.
6. Hold this gauge on the blade collar while pressing the  or  key, until the heavy line is even with the table top.
7. Press  key.

PLACE OVER LEFT BLADE COLLAR

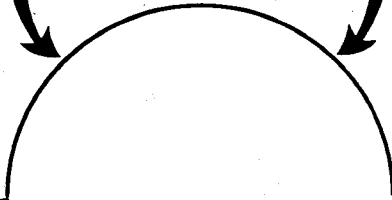

**PARTS LIST FOR CRAFTSMAN 10 INCH TABLE SAW
MODEL NO. 113.290600 & 113.290650**

REPAIR PARTS

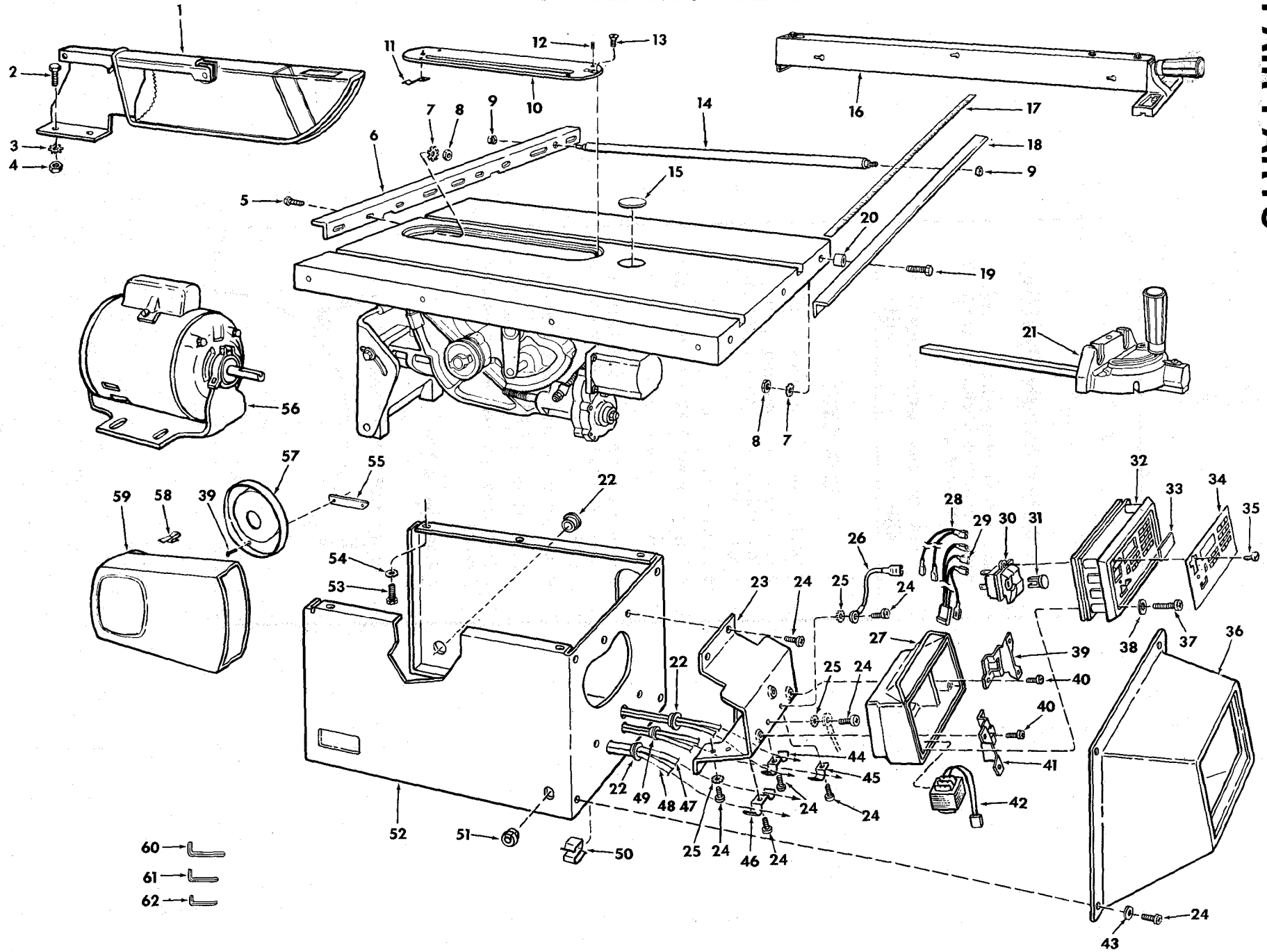

**FIGURE 1 PARTS LIST FOR CRAFTSMAN 10 INCH TABLE SAW
MODEL No. 113.290600 & 113.290650**

Always Order by Part Number - not by Key Number

Key No.	Part No.	Description
1	62579	Guard Assembly (See Fig. 5)
2	STD522506	*Screw, Hex Hd. 1/4-20 x 5/8
3	STD551225	*Lockwasher, External 1/4
4	STD541025	*Nut, Hex 1/4-20
5	STD523110	*Screw, Hex 5/16-18 x 1
6	62541	Bar, Fence Rear
7	STD551231	*Lockwasher, External 5/16
8	STD541231	*Nut, Hex 5/16-18
9	60388	Nut, Self-threading
10	62703	Insert Assembly, (Includes Key No. 11 & 12)
11	62718	Clip, Retaining
12	STD501102	*Screw, Locking Set 10-32 x 3/16
13	133645	Screw, Flat Hd. 10-32 x 1
14	62748	Rod, Separation (Includes Key No. 9)
15	62493	Insert, Exact-I-Cut
16	62773	Fence Assembly, Rip (See Fig. 3)
17	62710	Tape, Fence
18	62709	Bar Assembly, Fence Guide (Includes Key No. 17)
19	STD523117	*Screw, Hex Hd. 5/16-18 x 1-3/4
20	62539	Spacer, Fence Guide Bar
21	62704	Gauge Assembly, Miter (See Fig. 4)
22	60470	Bushing
23	62820	Bracket, Housing
24	STD610805	*Screw, Pan Cross Type "AB" No. 8 x 1/2
25	STD551208	*Lockwasher, External No. 8
26	75080	Lead, Grounding
27	75086	Housing, Bezel
28	75081	Lead
29	75082	Lead with terminals
30	62830	Switch, Locking
31	60256	Key, Switch
32	62842	Controls, Electronic T.S.
33	62826	Lens, Display
34	62827	Panel, Trim
35	STD510605	*Screw, Pan Hd. No. 6-32 x 1/2

Key No.	Part No.	Description
36	62825	Housing, Support
37	75084	Screw, Pan Hd. Plastite No. 6 x 2-1/4
38	STD551206	*Lockwasher, Internal #6
39	75088	Bracket, Grounding R.H.
40	STD601105	*Screw, Pan Cross Type "AB" No. 10-32 x 1/2
41	75087	Bracket, Grounding L.H.
42	62832	Transformer
43	9416712	Washer, 3/16 x 1/2 x 1/32
44	62847	Clamp, Cord
45	63418	Clamp, Cord
46	73151	Clamp, Cord
47	62823	Cord, Motor
48	62822	Cord, Power
49	60469	Bushing
50	62204	Clip, Cord
51	61086	Relief, Strain
52	62838	Base Assembly
53	454896	Screw, Hex Hd. 3/8-16 x 1/2
54	STD551237	*Lockwasher, External 3/8
55	60254	Bracket, Support
56	62817	Motor
57	60253	Support, Belt Guard
58	60255	Clip "S"
59	60252	Guard, Belt
60	37837	Wrench, Hex L 5/32
61	37887	Wrench, Hex L 1/8
62	37836	Wrench, Hex L 3/32
	62824	Owners' Manual (Not Illustrated)
	62834	Bag of Loose Parts (Not Illustrated)
	62835	Bag of Loose Parts (Not Illustrated)
	62836	Bag of Loose Parts (Not Illustrated)
	62837	Bag of Loose Parts (Not Illustrated)
	62844	Bag of Loose Parts (Not Illustrated)
	62845	Operation Information Card (Not Illustrated)
	62846	Gauge, Calibration (Not Illustrated)

*Standard Hardware Item - May be purchased locally.

NOTE: Shipping and handling charges for standard hardware items (identified by *) such as nuts, screws, washers, etc., make buying these items by mail uneconomical. To avoid shipping and handling charges, you may obtain most of these locally.

†Stock Item - May be secured through the hardware department of most Sears Retail Stores or Catalog Order Houses.



**PARTS LIST FOR CRAFTSMAN 10 INCH TABLE SAW
MODEL NO. 113.290600 & 113.290650**

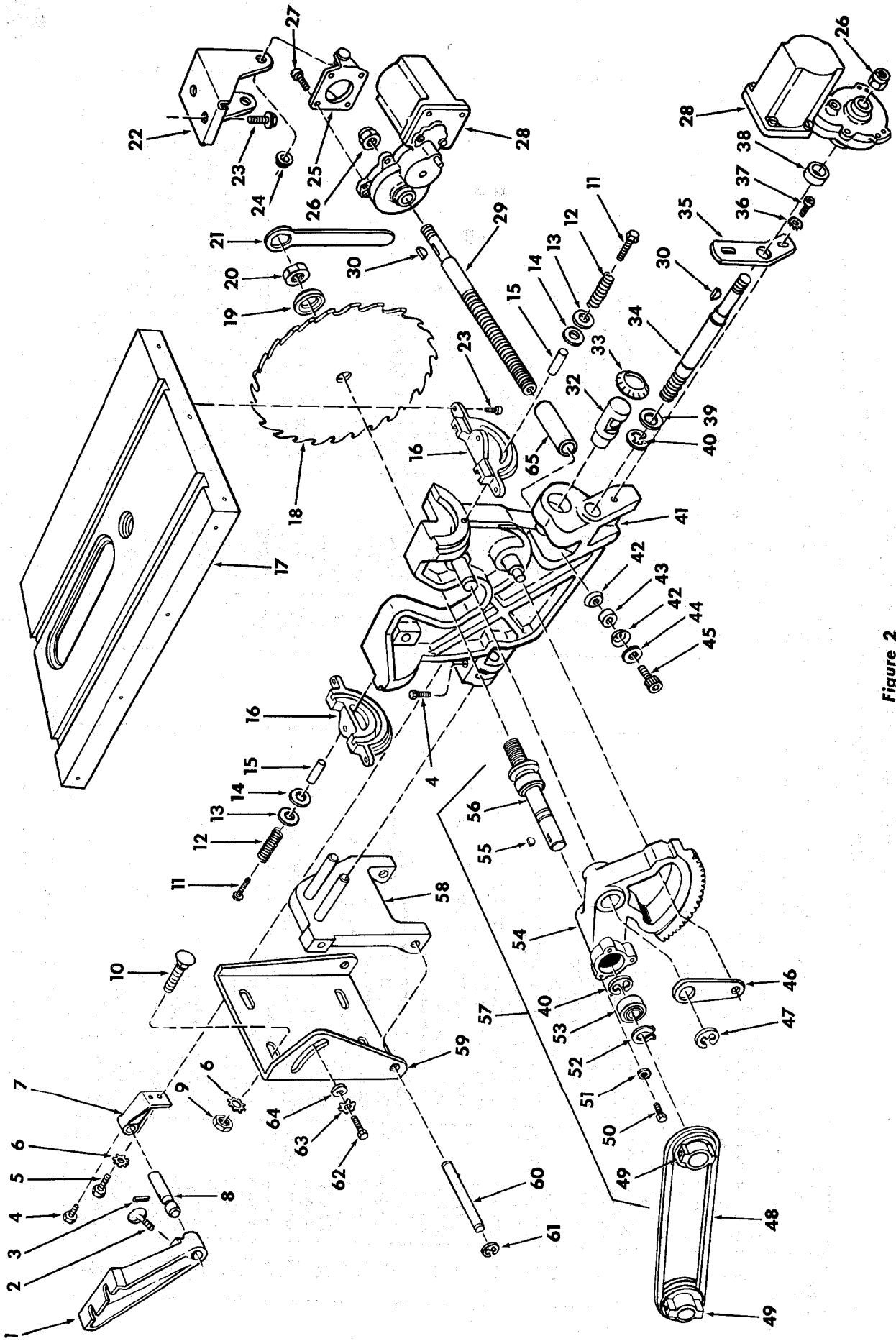

Figure 2



**PARTS LIST FOR CRAFTSMAN 10 INCH TABLE SAW
MODEL NO. 113.290600 & 113.290650**

Key No.	Part No.	Description
34	62828	Shaft, Elevation
35	62819	Bracket, Elevation
36	STD551210	*Lockwasher, External No. 10
37	STD601103	*Screw, Pan Cross Type "T" 10-32 x 3/8
38	60472	Spacer
39	37838	Washer, .629 x 7/8 x 1/64
40	STD581062	*Ring, Retaining 5/8
41	62843	Cradle, (Includes Key #31, 32, 43, & 44)
42	60473	Washer, Spring
43	60468	Spacer, Bushing
44	9414920	Washer, 17/64 x 9/16 x 1/16
45	60471	Screw, Hex Soc. Cap L.H. 1/4-20 x 7/8
46	62312	Link
47	6527	Ring, Retaining 3/4
48	STD304410	*Belt, V 1/2 x 41
49	STD328022	*Pulley, 5/8 Bore (Includes Set Screw)
50	STD600803	*Screw, Pan. Hd. Type "T" 8-32 x 3/8
51	9416712	Washer, 3/16 x 5/8 x 1/16
52	37158	Ring, Retaining 5/8
53	3509	Bearing, Saw Arbor
54	30420	Housing, Arbor
55	STD580025	*Key, Woodruff
56	6532	Arbor, (Includes Key Nos. 40, 52, 55)
57	30419	Housing, Arbor Assembly (Includes Key #40, 49, 50, 51, 52, 53, 54, 55 & 56)
58	37825	Support, Motor Base
59	37824	Base, Motor
60	37823	Pin, Hinge
61	STD581037	*Ring, Retaining
62	30628	Screw, Pivot Arm
63	6423	Washer, Spring
64	STD551025	*Washer, 17/64 x 47/64 x 1/16
65	62857	Spacer, 1/2" x 2-1/2"

Key No.	Part No.	Description
1	62587	Support, Spreader
2	60204	Screw, thumb 5/16-18 x 1
3	STD571812	*Pin, Roll 3/16 x 1-1/4
4	STD523106	*Screw, Hex Hd. 5/16-18 x 5/8
5	STD523110	*Screw, Hex Hd. 5/16-18 x 1
6	STD551231	*Lockwasher, External 5/16
7	62292	Support, Guard
8	62585	Spreader Rod
9	STD541231	*Nut, Hex 5/16-18
10	STD532507	*Bolt, Carriage 5/16-18 x 3/4
11	60206	*Screw, Hex Ind. Wash. Hd. 1/4-20 x 1-1/2
12	60205	Spring
13	STD551037	*Washer, .380 x 47/64 x 3/32
14	63011	Washer, Knob Clamp
15	62295	Spacer
16	62833	Trunnion, Table
17	62831	Table, 10 In. Saw
18	60175	†Blade, Saw 10 In.
19	62498	Collar, Blade
20	6362	Nut, Arbor
21	3540	Wrench, Arbor
22	62821	Bracket, Bevel
23	STD551237	*Screw, Sems 3/8-16 x 1
24	60208	Nut, Push
25	62840	Support, Transmission
26	STD541437	*Nut, Lock 3/8-16
27	STD601105	*Screw, Pan Cross Type "T" 10-32 x 1/2
28	62839	Transmission Assembly
29	62829	Shaft, Bevel
30	STD580013	*Key, Woodruff #2
32	62841	Nut, Bevel
33	63054	Ring, Retaining

*Standard Hardware Item - May be Purchased Locally.

†Stock Item - May be secured through the Hardware Department of most Sears Retail Stores or Catalog Order Houses.

**PARTS LIST FOR CRAFTSMAN 10 INCH TABLE SAW
MODEL NO. 113.290600 & 113.290650**

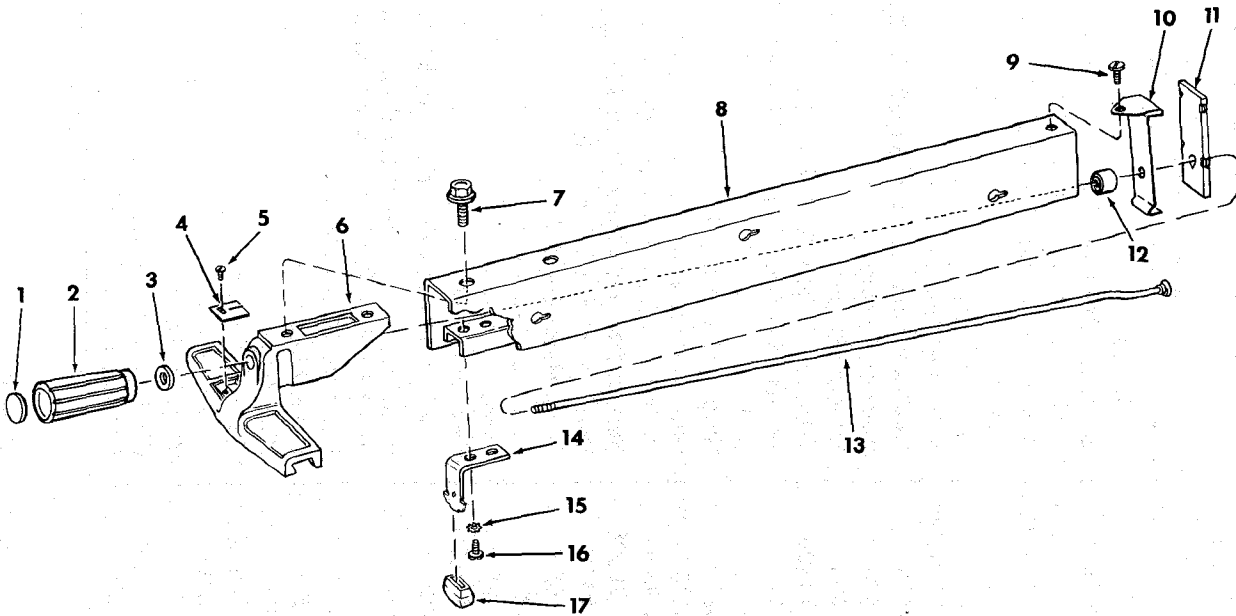

FIGURE 3 - 62773 FENCE ASSEMBLY

Key No.	Part No.	Description
-	62773	Fence Assembly, Rip
1	62693	Plug, Button
2	62692	Knob (Includes Key No. 1)
3	STD551031	*Washer, 21/64 I.D.
4	62775	Indicator, Fence
5	9404336	*Screw, Pan Hd. Type "T" 4-40 x 1/4
6	62774	Head, Fence Includes Key #4
7	423350	Screw, Sems 3/8-16 x 1/2
8	62582	Channel, Fence
9	STD600805	*Screw, Pan Hd. Type "T" 8-32 x 1/2
10	62528	Spring, Fence Lock
11	62529	Lock, Rear Fence
12	62531	Roller, Rear Fence
13	62583	Rod, Fence Lock
14	62533	Spring, Head Alignment (Includes Key No. 17)
15	STD551210	*Lockwasher, External No. 10
16	STD611005	*Screw, Type "A", Hex Ind. Sl. Wash. Hd. No. 10 x 1/2
17	62532	Pad, Alignment

*Standard Hardware Item - May Be Purchased Locally.

**PARTS LIST FOR CRAFTSMAN 10 INCH TABLE SAW
MODEL NO. 113.290600 & 113.290650**

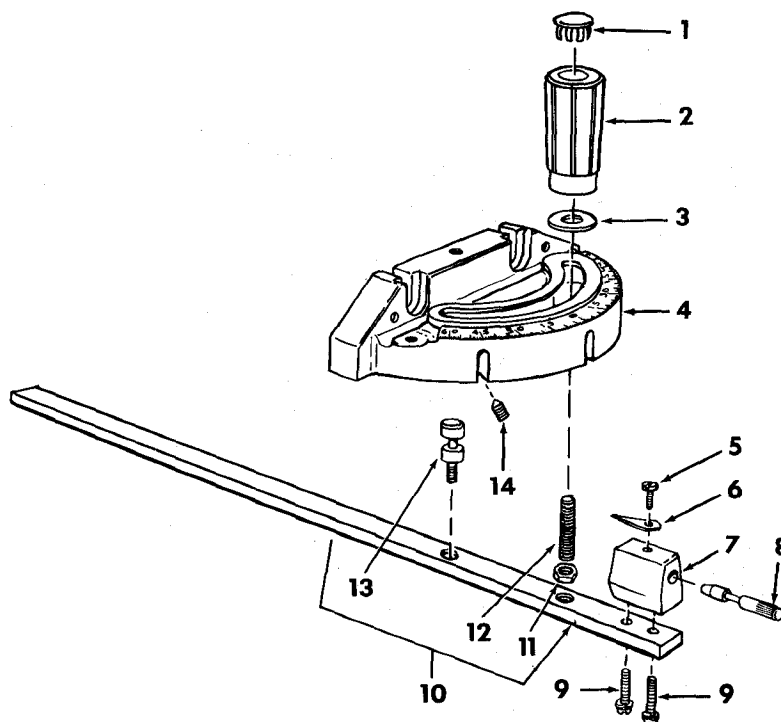

FIGURE 4 - 62704 MITER GAUGE ASSEMBLY

Key No.	Part No.	Description
-	62704	†Gauge Assembly, Miter
1	62693	Plug, Button
2	62692	Knob, Miter Gauge (Includes Key No. 1)
3	STD551237	*Washer, Plain 21/64 x 1 x 1/16"
4	37893	Gauge, Miter
5	STD510803	*Screw, Pan Hd. 8-32 x 5/16"
6	135	Indicator
7	37895	Block, Miter Gauge Indicator
8	37896 9417295	Pin, Miter Gauge Stop *Screw, Pan Hd., w/ Lockwasher, 8-32 x 5/8"
10	62230	Rod Assembly, Miter Gauge, Consisting of Items 11, 12, 13
11	STD541231	*Nut, Hex., 5/16-18
12	62225	Stud, Clamp
13	62383	Stud, Pivot
14	60288	Screw, Locking Set, 1/4 -20 x 3/8"

*Standard Hardware Item - May be Purchased Locally.

†Stock Item - May be secured through the Hardware Departments of most Sears Retail Stores or Catalog Order Houses.

**PARTS LIST FOR CRAFTSMAN 10 INCH TABLE SAW
MODEL NO. 113.290600 & 113.290650**

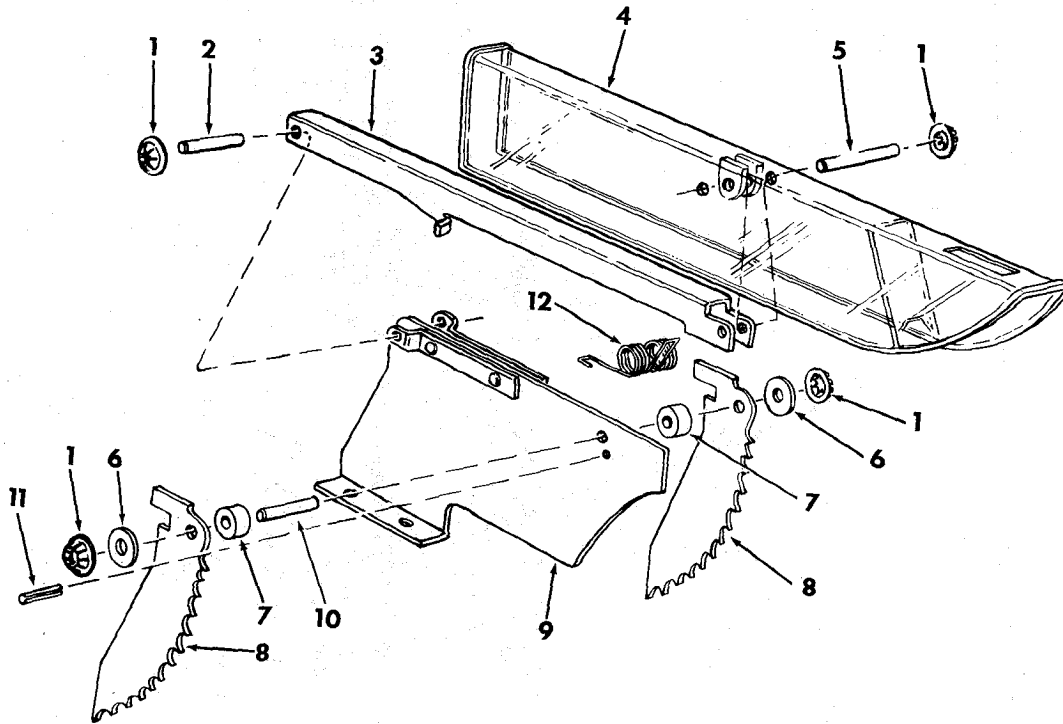

FIGURE 5 - 62579 GUARD ASSEMBLY

Key No.	Part No.	Description
	62579	Guard Assembly, Saw
1	60297	Nut, Push
2	62391	Pin 1/4 x 1-1/2"
3	62395	Support, Guard
4	62389	Guard, Saw
5	62390	Pin, 1/4 x 1-3/4"
6	STD551025	*Washer, 17/64 x 5/8 x x 1/16"
7	62520	Spacer, Pawl
8	62396	Pawl
9	62580	Spreader, Assembly Blade
10	62410	Pin, 1/4 x 1"
11	STD571810	*Pin, Roll, 3/16 x 15/16"
12	62519	Spring, Pawl

*Standard Hardware Item - May Be Purchased Locally

†Stock Item - May be secured through the Hardware Department of most Sears Retail Stores or Catalog Order Houses.

**PARTS LIST FOR CRAFTSMAN 10 INCH TABLE SAW
MODEL No. 113.290600 & 113.290650**

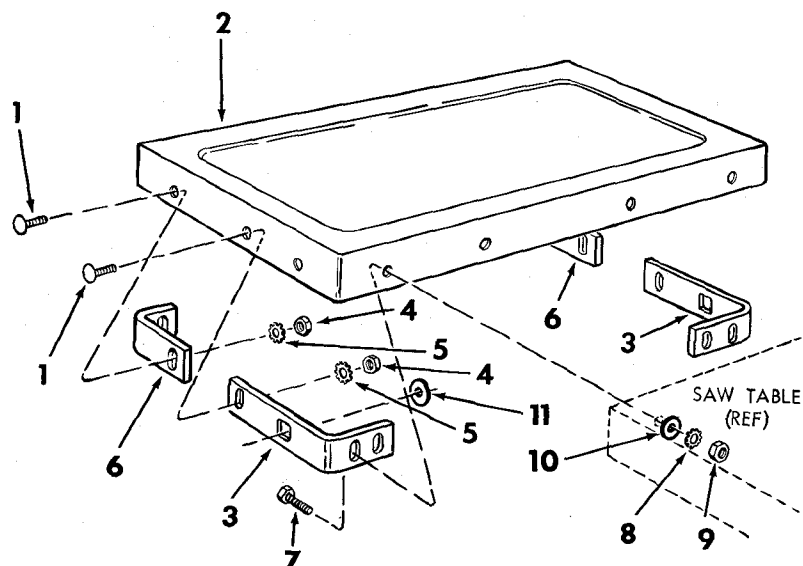

**FIGURE 6 - TABLE EXTENSION
SUPPLIED WITH MODEL 290650 ONLY**

Key No.	Part No.	Description
-	62589	†Extension Assembly, Complete
1	60323	Screw, Serrated Truss Hd., 1/4-20 x 1"
2	62590	Extension
3	62549	Bracket, Corner Support
4	STD541025	*Nut, Hex 1/4-20
5	STD551225	*Lockwasher, Ext. 1/4
6	62550	Bracket, Corner Stiffener
7	STD523112	*Screw, Hex Hd., 5/16-18 x 1-1/4
8	STD551131	*Lockwasher, Ext. 5/16
9	STD541031	*Nut, Hex 5/6-18
	62745	•Bag of Loose Parts (not illustrated)
10	STD551031	*Flat Washer, 11/32 I.D.
11	STD551025	*Flat Washer, 17/64 I.D.

*Standard Hardware Items - May be Purchased Locally.

•Bag contains all Loose Parts for Extensions.

†Stock Item - May be secured through the Hardware Department of most Sears retail stores or catalog order houses.



**PARTS LIST FOR CRAFTSMAN 10 INCH TABLE SAW
MODEL NO. 113.290600 & 113.290650**

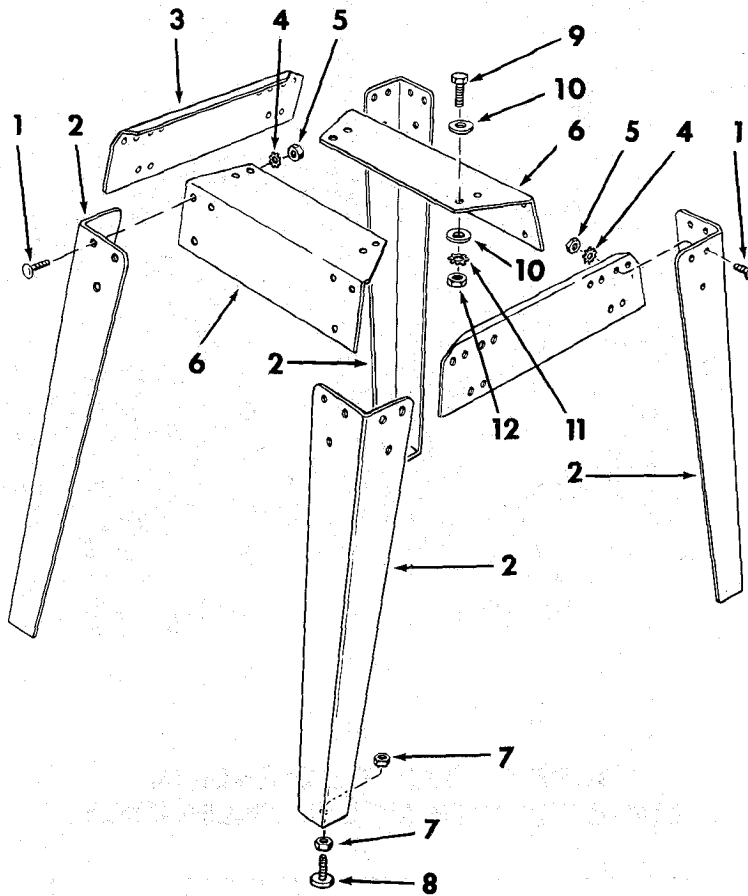

**FIGURE 7 - LEGS SUPPLIED WITH
MODEL 290650 ONLY**



















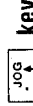

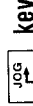
Key No.	Part No.	Description
1	60314	Screw, Serrated Truss Hd. 1/4-20 x 5/8
2	62552	Leg
3	62554	Stiffener, Side
4	STD551225	*Lockwasher, Ext. 1/4
5	STD541025	*Nut, Hex 1/4-20
6	62553	Stiffener, End
7	STD541250	*Nut, Hex 1/2-13
8	803835	Foot, Leveling
HARDWARE FOR ATTACHING LEGS TO SAW		
9	STD523112	*Screw, Hex Hd. 5/16-18 x 1-1/4
10	STD551031	Washer, 11/32 I.D.
11	STD551131	*Lockwasher, Ext. 5/16
12	STD541031	*Nut, Hex 5/16-18
	62752	•Bag of Loose Parts For Legs (not illustrated)

*Standard Hardware Items - May be Purchased Locally.
•Bag contains all Loose Parts for Leg Set.

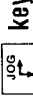































ELECTRONIC TABLE SAW CONTROL PANEL OPERATIONS

DO NOT OPERATE SAW WITHOUT FIRST READING AND UNDERSTANDING OWNER'S MANUAL. YOUR MANUAL CONTAINS SAFETY INSTRUCTIONS AND DETAILED EXPLANATIONS OF KEYBOARD FUNCTIONS AND BASIC SAW OPERATIONS.

DANGER

RESULT DESIRED	ACTION REQUIRED	DISPLAY
1. To turn on display	Plug in saw; Turn Master Switch "ON"	Flashing 
2. To "Calibrate" saw's computer	Press  key. "JOG" blade to measure square to table Press  key. "JOG" blade so tip of blade is even with top of table Press  key	  
3. To "JOG" blade up	Press  key. Press  key	Read current position
4. To "JOG" blade down	Press  key. Press  key	Read current position
5. To program to a Desired elevation	Press  key Press number keys for desired position Press  key	Current position Desired position Current position
6. To "JOG" to a bevel angle	Press  key. Press either  or  key	Read current position
7. To program to a Desired bevel angle	Press  key Press number keys for desired angle Press  key	Current angle Desired angle Current angle
8. To program to a desired elev. and bevel angle	Press  key Press number keys for desired position Press  key Press  key Press number keys for desired angle Press  key	Current position Desired position Desired position Current angle Desired angle Current angle/then current position

NOTE: To stop a programmed motion press  key or push MASTER switch "OFF".

DECIMAL EQUIVALENTS
 .030
 .060
 .095
 .125
 .155
 .185
 .220
 .250
 .280
 .310
 .345
 .375
 .405
 .435
 .470
 .500
 .530
 .560
 .595
 .625
 .655
 .685
 .720
 .750
 .780
 .810
 .845
 .875
 .905
 .935
 .970
 1.000

NOTE: All decimals are rounded to the nearest .005 inch.

Sears

*owners
manual*

SERVICE

**MODEL NO.
113.290600**

SAW WITH
MOTOR ONLY

113.290650

SAW WITH MOTOR,
LEGS AND
TWO TABLE EXTENSIONS

**HOW TO ORDER
REPAIR PARTS**

10 INCH ELECTRONIC TABLE SAW

Now that you have purchased your 10-inch electronic table saw should a need ever exist for repair parts or service, simply contact any Sears Service Center and most Sears, Roebuck and Co. stores. Be sure to provide all pertinent facts when you call or visit.

The model number of your 10-inch electronic table saw will be found on a plate attached to your saw, at the left-hand side of the base.

WHEN ORDERING REPAIR PARTS, ALWAYS GIVE THE FOLLOWING INFORMATION:

PART NUMBER	PART DESCRIPTION
MODEL NUMBER	NAME OF ITEM
113.290600	10-INCH ELECTRONIC
113.290650	TABLE SAW

All parts listed may be ordered from any Sears Service Center and most Sears stores. If the parts you need are not stocked locally, your order will be electronically transmitted to a Sears Repair Parts Distribution Center for handling.

Sold by SEARS, ROEBUCK AND CO., Chicago, IL. 60684 U.S.A.