

Operating and installation instructions

Ceramic cooktops



To prevent the risk of accidents or damage to the appliance, it is **essential** to read these instructions before it is installed and used for the first time.

Contents

Warning and Safety instructions	4
Caring for the environment	14
Overview	15
Cooktop	15
KM 6520 FR, KM 6520 FL	15
KM 6522 FR	16
KM 6527 FR	17
Controls and display	18
Cooking zone data	20
Before using for the first time	21
Cleaning the cooktop for the first time	21
Switching on the cooktop for the first time	21
How the cooking zones work	22
Pans	23
Tips on saving energy	24
Power level range	25
Operation	26
Operating principles	26
Switching on the cooktop	27
Setting the power level	27
Changing the power level	27
Switching off a cooking zone/the cooktop	27
Residual heat indicator	28
Setting the power level - extended setting range	28
Extension	29
Auto heat-up	30
Timer	31
Minute minder	31
Switching off a cooking zone automatically	32
Using both timer functions at the same time	33
Additional functions	34
Stop & Go	34
Recall	34
Demonstration mode	35
Displaying cooktop data	35

Safety features	36
System lock / Safety lock.....	36
Safety switch-off	38
Overheating protection.....	39
Programming	40
Cleaning and care	43
Problem solving guide	45
Optional accessories	48
Safety instructions for installation	49
Safety distances	50
Installation notes	52
Installation of surface-mounted appliances	52
Flush-mounted installation	53
Installation dimensions – Surface-mounted	54
KM 6520 FR	54
KM 6522 FR	55
KM 6527 FR	56
Installation dimensions – Flush	57
KM 6520 FL.....	57
Installation	58
Installation of surface-mounted appliances	58
Flush-mounted installation	60
Electrical connection	61
Disconnecting devices	61
Service	63
Contact in case of fault	63
Data plate	63
Warranty	63

Warning and Safety instructions

This appliance conforms to current safety requirements. Inappropriate use can, however, lead to personal injury and damage to property.

To avoid the risk of accidents and damage to the appliance, please read these instructions carefully before using it for the first time. They contain important notes on installation, safety, use and maintenance.

Miele cannot be held liable for non-compliance with these instructions.

Keep these instructions in a safe place and ensure that new users are familiar with the contents. Pass them on to any future owner.

Correct application

- ▶ This cooktop is designed for domestic use and for use in similar environments by guests in hotel or motel rooms, bed & breakfasts and other typical living quarters. This does not include common/shared facilities or commercial facilities within hotels, motels or bed & breakfasts.
- ▶ This cooktop is not suitable for outdoor use.
- ▶ It is intended only to cook food and keep it warm. Any other use is not supported by Miele and could be dangerous.
- ▶ This cooktop is not intended for use by people (including children) with reduced physical, sensory or mental capabilities or lack of experience and knowledge, unless they have been given supervision and instruction concerning its use by a person responsible for their safety. They may only use the cooktop unsupervised if they have been shown how to use it in a safe way. They must be able to recognise and understand the potential dangers of improper use.

Warning and Safety instructions

Safety with children

- ▶ Young children must not be allowed to use this appliance.
- ▶ Older children may use the appliance without supervision if its operation has been clearly explained to them and they are able to use it safely. Children must be able to recognise and understand the potential dangers of improper use.
- ▶ Cleaning may only be carried out by older children under the supervision of an adult.
- ▶ Please supervise children in the vicinity of the cooktop and do not let them play with it.
- ▶ The cooktop gets hot when in use and remains hot for a while after being switched off. Keep children well away from the cooktop until it has cooled down and there is no danger of burning.
- ▶ **Danger of burning!**
Do not store anything which might arouse a child's interest in storage areas above or behind the cooktop. Otherwise children could be tempted to climb onto the cooktop.
- ▶ **Danger of burning and scalding!**
Turn the handles of pots and pans on the cooking zone to the side or the rear so that children cannot pull them down and burn themselves.
- ▶ **Danger of suffocation!**
Whilst playing, children may become entangled in packaging material (such as plastic wrapping) or pull it over their head with the risk of suffocation. Keep packaging material away from children.
- ▶ Activate the system lock to ensure that children cannot switch on the cooktop inadvertently. Use the safety lock when the cooktop is in use to prevent children from altering the settings selected.

Technical safety

- ▶ Unauthorised installation, maintenance and repairs can cause considerable danger for the user. Installation, maintenance and repairs must only be carried out by a Miele authorised technician.
- ▶ Damage to the cooktop can compromise your safety. Check the appliance for visible signs of damage. Do not use the cooktop if it is damaged.
- ▶ Reliable and safe operation of this cooktop can only be assured if it has been connected to the mains electricity supply.
- ▶ The electrical safety of this appliance can only be guaranteed when continuity is complete between it and an effective earthing system which complies with local and national safety regulations. It is most important that this basic safety requirement is present and tested regularly and, where there is any doubt, the household wiring system should be inspected by a qualified electrician.
- ▶ Before connecting the appliance to the mains supply, ensure that the connection data on the data plate (voltage and frequency) matches the mains electricity supply. This data must correspond in order to avoid the risk of damage to the appliance.
- ▶ Do not connect the cooktop to the mains electricity supply by a multi-socket adapter or extension lead. These are a fire hazard and do not guarantee the required safety of the appliance.
- ▶ For safety reasons, this cooktop may only be used after it has been built in.
- ▶ This appliance must not be installed and operated in mobile installations (e.g. on a ship).
- ▶ Never open the casing of the cooktop.
Touching or tampering with electrical connections or components and mechanical parts is highly dangerous to the user and can cause operational faults.

Warning and Safety instructions

- ▶ The manufacturer's warranty will be invalidated if the appliance is not repaired by a Miele approved service technician.
- ▶ Faulty components must only be replaced by genuine Miele spare parts. The manufacturer can only guarantee the safety of the appliance when Miele replacement parts are used.
- ▶ The cooktop is not intended for use with an external timer switch or a remote control system.
- ▶ The cooktop must be connected to the electricity supply by a qualified electrician (see “Electrical connection”).
- ▶ If the mains connection cable is damaged, it must be replaced with a special connection cable by an electrician in order to avoid a hazard (see “Electrical connection”).
- ▶ During installation, maintenance and repair work, the appliance must be disconnected from the mains electricity supply. It is only completely isolated from the electricity supply when:
 - the mains circuit breaker is switched off, or
 - it is switched off at the wall socket and the plug is withdrawn from the socket. Do not pull the mains connection cable but the mains plug to disconnect your appliance from the mains electricity supply.
- ▶ **Danger of electric shock!**
If the ceramic surface is faulty, cracked, chipped or damaged in any way, switch off the cooktop immediately. Disconnect the cooktop from the mains electricity supply. Contact Miele.
- ▶ If the cooktop is installed behind a furniture door, do not close the door while the cooktop is in operation. Heat and moisture can build up behind the closed door. This can result in damage to the cooktop, the housing unit and the floor. Do not close the door until the residual heat indicators have gone out.

Warning and Safety instructions

- ▶ In areas which may be subject to infestation by cockroaches or other vermin, pay particular attention to keeping the appliance and its surroundings clean at all times. Any damage caused by cockroaches or other vermin will not be covered by the warranty.
- ▶ DO NOT MODIFY THIS APPLIANCE.

Warning and Safety instructions

Correct use

- ▶ The cooktop gets hot when in use and remains hot for a while after being switched off. There is a danger of burning until the residual heat indicators go out.
- ▶ Do not use the appliance to heat up the room. Due to the high temperatures radiated, objects left near the appliance could catch fire.
- ▶ Oil and fat can overheat and catch fire. Do not leave the cooktop unattended when cooking with oil and fat. If it does ignite, do not attempt to put the flames out with water. Switch off the cooktop and use a suitable fire blanket, saucepan lid, damp towel or similar to smother the flames.
- ▶ The cooking process has to be supervised. A short term cooking process has to be supervised continuously.
- ▶ Flames could set the grease filters of a rangehood on fire. Do not flambé under a rangehood.
- ▶ Spray canisters, aerosols and other inflammable substances can ignite when heated. Therefore do not store such items or substances in a drawer under the cooktop. Cutlery inserts must be heat-resistant.
- ▶ Do not heat an empty pan.
- ▶ Do not heat up food in closed containers e.g. tins or sealed jars on the cooktop, as pressure can build up in the containers, causing them to explode.
- ▶ Do not cover the cooktop, e.g. with a cooktop cover, a cloth or protective foil. The material could catch fire, shatter or melt if the cooktop is switched on by mistake or if residual heat is still present.

Warning and Safety instructions

- ▶ When the appliance is switched on either deliberately or by mistake, or when there is residual heat present, there is the risk of any metal items left on the cooktop heating up, with the danger of burning. Depending on the material, other items left on the cooktop could also melt or catch fire. Damp pan lids might adhere to the ceramic surface and be difficult to dislodge. Do not use the appliance as a resting place. Switch the cooking zones off after use and do not rely on the pan detector.
- ▶ You could burn yourself on the hot cooktop. Protect your hands with heat-resistant pot holders or gloves when handling hot pots and pans. Do not let them get wet or damp, as this causes heat to transfer through the material more quickly with the risk of scalding or burning yourself.
- ▶ When using an electrical appliance, e.g. a hand-held food mixer, near the cooktop, ensure that the cable of the electrical appliance cannot come into contact with the hot cooktop. The insulation on the cable could become damaged.
- ▶ Grains of salt, sugar and sand (e.g. from cleaning vegetables) can cause scratches if they get under pan bases. Make sure that the ceramic surface is clean before placing pans on it.
- ▶ Even a light object can cause damage in certain circumstances. Do not drop anything on the ceramic surface.
- ▶ Placing hot pans on the sensors and indicators could damage the electronics underneath. Do not place hot pans on the sensors or indicators.

Warning and Safety instructions

- ▶ Do not allow solid or liquid sugar, or pieces of plastic or aluminium foil to get onto the cooktop when it is hot, as they can damage the ceramic surface when it cools down. If this should occur, switch off the appliance and scrape off all the sugar, plastic or aluminium residues whilst still hot, using a shielded scraper blade suitable for use on glass. Wear oven gloves when doing this. Allow the ceramic surface to cool down and then clean it with a suitable ceramic cooktop cleaning agent.
- ▶ Pans which boil dry can cause damage to the ceramic glass. Do not leave the cooktop unattended whilst it is being used.
- ▶ Only use pots and pans with smooth bases. Rough bases will scratch the ceramic glass.
- ▶ Lift pans into position on the cooktop. Sliding them into place can cause scuffs and scratches.
- ▶ Plastic and aluminium foil containers melt at high temperatures. Do not use plastic or aluminium foil containers on the cooktop.
- ▶ The cooktop frame or cooktop edges (on cooktops with bevelled edges) and the controls can become hot due to the influence of the following factors: operating duration, high power level(s), large pans and the number of cooking zones being used.
- ▶ Cookware that is made of aluminium or has an aluminium base can leave behind shiny metallic spots. These can be removed with the ceramic and stainless steel cooktop cleaner (see “Cleaning and care”).
- ▶ If spills remain on the cooktop for any length of time they can burn on and in certain circumstances become impossible to remove. Remove any soiling as quickly as possible and ensure that pan bases are clean, dry and free of grease.
- ▶ Do not use the ceramic surface for preparing food. Always use suitable pots and pans.

Cleaning and care

- ▶ Do not use a steam cleaning appliance to clean this appliance. The steam could reach the electrical components and cause a short circuit.

Caring for the environment

Disposal of the packing material

The transport and protective packaging has been selected from materials which are environmentally friendly for disposal, and can normally be recycled.

Recycling the packaging reduces the use of raw materials in the manufacturing process and also reduces the amount of waste in landfill sites. Ensure that any plastic wrappings, bags etc. are disposed of safely and kept out of the reach of babies and young children. Danger of suffocation.

Disposing of your old appliance

Electrical and electronic appliances often contain valuable materials. They also contain specific materials, compounds and components, which were essential for their correct function and safety. These could be hazardous to human health and to the environment if disposed of with your domestic waste or if handled incorrectly. Please do not, therefore, dispose of your old appliance with your household waste.



Please dispose of it at your local community waste collection / recycling centre for electrical and electronic appliances. You are also responsible for deleting any personal data that may be stored on the appliance prior to disposal. Please ensure that your old appliance poses no risk to children while being stored prior to disposal.

Cooktop

KM 6520 FR, KM 6520 FL

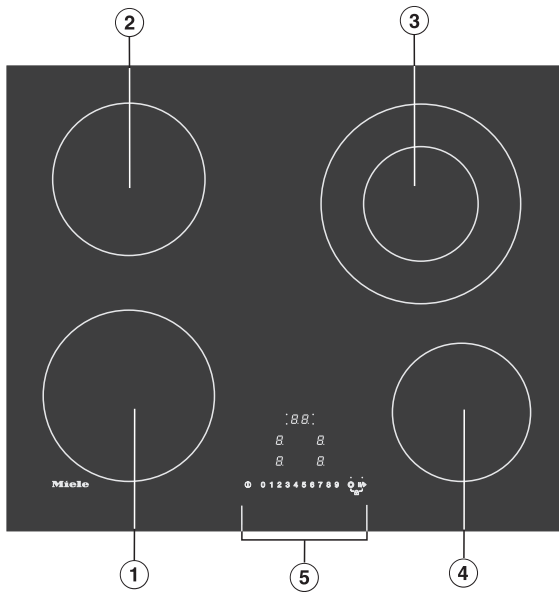

- ① Single circle zone
- ② Single circle zone
- ③ Double circle zone
- ④ Single circle zone
- ⑤ Controls and indicators

Overview

KM 6522 FR

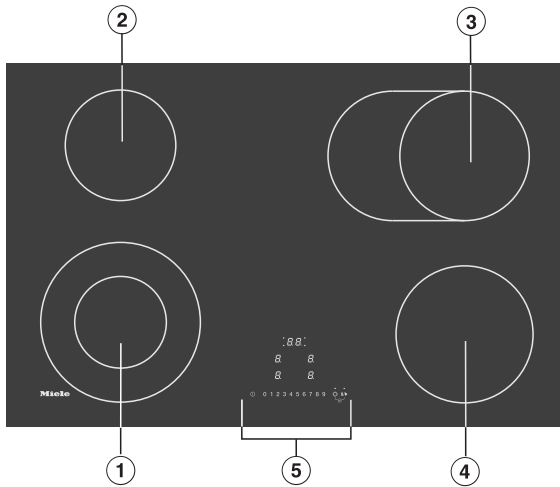

- ① Double circle zone
- ② Single circle zone
- ③ Extended cooking zone
- ④ Single circle zone
- ⑤ Controls and indicators

KM 6527 FR

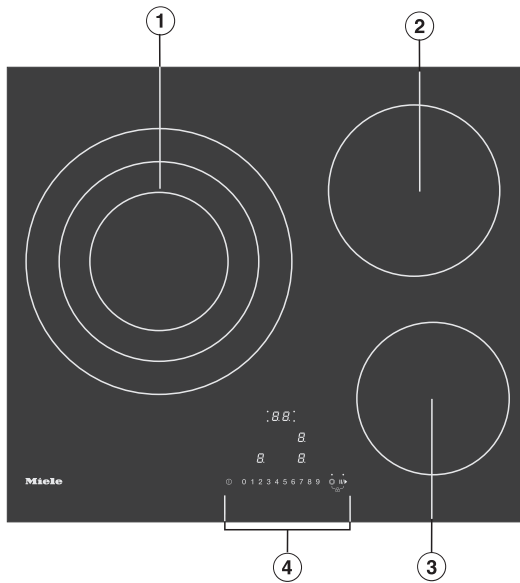

- ① Triple circle zone
- ② Single circle zone
- ③ Single circle zone
- ④ Controls and indicators

Overview

Controls and display

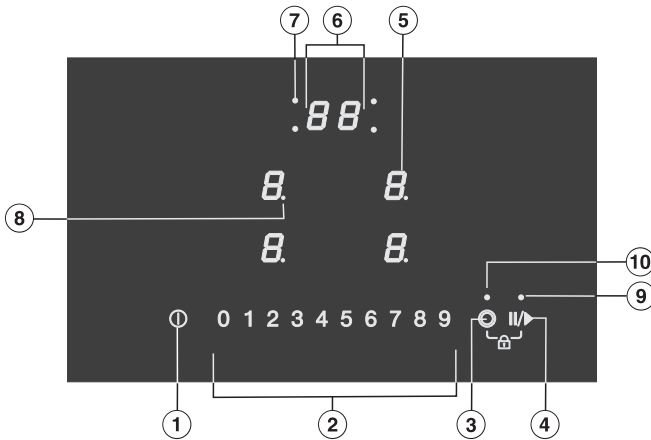

Sensor controls

- ① For switching the cooktop on/off
- ② Numerical keybank
 - For setting the power level
 - For setting the timer
- ③ For switching on an extended cooking zone
- ④ Stop & Go
- ⑤ Cooking zone selection and display

<i>0</i>	Cooking zone ready for use
<i>h</i>	Keep warm setting
<i>1 to 9</i>	Power level
<i>≡</i>	Residual heat
<i>R</i>	Auto heat-up

Display / Indicator lights

- ⑥ Timer display
 - 00 to 99* Duration in minutes
 - LC* System lock/Safety lock activated
 - dE* Demonstration mode activated
- ⑦ Automatic switch-off allocation of cooking zones

- ⑧ Extended power level range setting
- ⑨ Stop & Go activated
- ⑩ Extension

Overview

Cooking zone data

KM 6520 FR, KM 6520 FL		
Cooking zone	Ø in cm	Rating in watts for 230 V
①	18.0	1800
②	16.0	1500
③	12.0/21.0	750/2200
④	14.5	1200
		Total: 6700

KM 6522 FR		
Cooking zone	Ø in cm	Rating in watts for 230 V
①	12.0/21.0	750/2200
②	14.5	1200
③	17.0 / 17.0 x 29.0	1500/2400
④	18.0	1800
		Total: 7600

KM 6527 FR		
Cooking zone	Ø in cm	Rating in watts for 230 V
①	14.5/21.0/27.0	1200/2300/3400
②	18.0	1800
④	16.0	1500
		Total: 6700

Before using for the first time

- Please stick the extra data plate for the appliance supplied with this documentation in the space provided in the “Service” section of this booklet. Alternatively, the additional label can be stuck near the appliance if the appliance markings are not visible after installation.
- Remove any protective wrapping and stickers.

Cleaning the cooktop for the first time

- Before using for the first time, clean the cooktop with a damp cloth only and then wipe dry.

Switching on the cooktop for the first time

The metal components have a protective coating which when heated for the first time will give off a slight smell and possibly some vapours.

The smell and any vapours given off do not indicate a faulty connection or appliance and they are not hazardous to health.

How the cooking zones work

Single circle cooking zones have one heating element, whilst double circle cooking zones and extended zones have two. Depending on the model, the heating elements may be separated by an insulating ring.

Each cooking zone has overheating protection (a temperature limiter), which stops the ceramic surface from becoming too hot (see “Safety features - Overheating protection”).

When a power level is selected, the heating switches on and the element can be seen through the ceramic surface. The temperature of the cooking zones depends on the power level selected and is electronically regulated. This controls the “timing” of a cooking zone, switching the element on and off.

Single circle zone

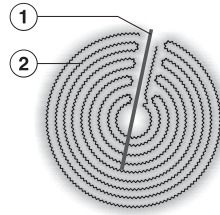

- ① Overheating protection
- ② Heating element

Double circle zone

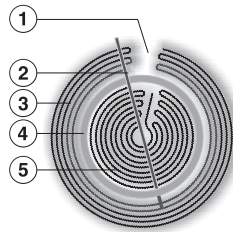

- ① Technical requirement, not a defect
- ② Overheating protection
- ③ Outer heating element
- ④ Insulating ring
- ⑤ Inner heating element

The most suitable cookware is metal pots and pans with thick bases that, when cold, bulge inwards slightly. On warming, the base flattens and sits level on the cooking zone. This optimises the conduction of heat.

- Please note that the maximum diameter quoted by manufacturers often refers to the diameter of the top rim of the pot or pan. The diameter of the base (generally smaller) is more important.

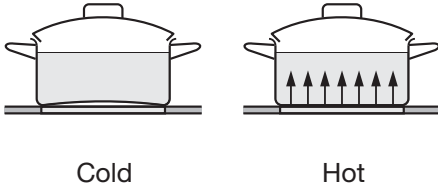

Glass, ceramic, or stoneware is **less suitable**. These materials do not conduct the heat well.

Cookware made of synthetic material or aluminium is **not suitable**. These melt at high temperatures.

Cookware that is made of aluminium or has an aluminium base can leave behind shiny metallic spots. These can be removed with the ceramic and stainless steel cooktop cleaner (see “Cleaning and care”).

Please be aware that the properties of the pan base can affect the evenness with which the food heats up (e.g. when making pancakes).

- To make optimum use of the cooking zones, choose pans with a suitable base diameter (see chapter “Cooking zones”).
- Use only pots and pans with smooth bases. Rough bases can scratch the ceramic glass.
- Always lift the pans to move them. This will help prevent scratching.

Tips on saving energy

- Check that the diameter of the pan base is wide enough for the cooking zone so that heat is not lost unnecessarily.

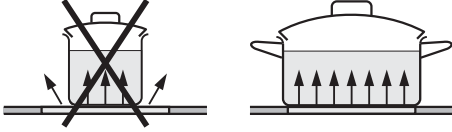

- Use a pan lid whenever possible to minimise heat loss.
- Select a smaller pan when cooking small quantities. A small pan on a small cooking zone uses less energy than a large, partially filled pan on a large cooking zone.
- Cook with as little water as possible.
- Once food has come to the boil or the oil in the pan is hot enough for frying, reduce the heat to a lower setting.
- When cooking for a long time, switch the cooking zone off about 5 to 10 minutes before the end of the cooking time. In this way, use is made of the residual heat.
- Use a pressure cooker to reduce cooking times.

Power level range

The cooktop is programmed with 9 power levels at the factory. If you wish to fine-tune a setting, you can extend the power level range to 17 power levels (see “Programming”).

	Power level range	
	Default setting (9 power levels)	Extended settings (17 power levels)
Melting butter, chocolate etc. Dissolving gelatine	1–2	1–2.
Warming small quantities of food/liquids Keeping warm food which sticks easily Cooking rice	1–3	1–3.
Warming liquid and semi-solid foods Thickening sauces, e.g. Hollandaise Making porridge Preparing omelettes, lightly fried eggs Steaming fruit	2–4	2–4.
Defrosting deep frozen food Steaming vegetables, fish Cooking pasta, pulses Cooking broths, pulse soups	3–6	3–5.
Bringing to the boil and continued cooking of large quantities of food	4–6	4.–5.
Gently frying meat, schnitzel, fish, sausages, eggs etc. (without overheating the fat)	6–7	6–7.
Cooking potato fritters, pancakes etc.	7–8	7–8.
Boiling large quantities of water Searing large amounts of meat Bringing to the boil	8–9	8.–9

These settings should only be taken as a guide. They apply to 4 normal servings. With deep pans, large quantities or when cooking without the lid, a higher setting is required. For smaller quantities, select a lower setting.

Operation

Operating principles

This ceramic cooktop is equipped with electronic sensor controls which react to finger contact. For safety reasons, when switching the appliance on, the On/Off ① sensor needs to be touched for a little longer than the other sensors. Each time you touch a sensor, an acoustic signal sounds.

When the cooktop is switched off, only the printed sensor control symbols and numbers on the keybank for setting the power levels are visible. More sensor controls light up when the cooktop is switched on.

In order to set or alter a power level, the cooking zones must be “active”. To activate a cooking zone, touch the indicator of the relevant cooking zone. The relevant cooking zone indicator will begin to flash when touched. While the indicator is flashing, you can set or adjust the power level or the duration.

Exception: If only one of the cooking zones is in operation, you can alter the power level without activating the cooking zone.

 Malfunction due to dirty and/or covered sensor controls.

If the sensor controls are dirty or covered this could cause them to fail to react, to activate a function inadvertently or even to switch the appliance off automatically (see “Safety switch-off”). Placing hot pans on the sensor controls/ indicators can damage the electronic unit underneath.

Keep the sensor controls and indicators clean.

Do not place anything over the sensor control or indicators.

Do not place hot pans over the sensor controls or indicators.

 Risk of fire with overheated food. Unattended food can overheat and ignite. Do not leave the cooktop unattended whilst it is being used.

Switching on the cooktop

- Touch the ① sensor.

Further sensor controls will light up.

If no further entry is made, the cooktop will switch itself off after a few seconds for safety reasons.

Setting the power level

- Place a pan on the cooking zone you want to use.
- Touch the relevant cooking zone indicator.

The cooking zone indicator control will begin to flash.

- Touch the appropriate sensor control on the numerical keybank for the power level you want.

The power level selected will flash in the display for a few seconds and then light up constantly.

Changing the power level

- Touch the relevant cooking zone indicator.

The cooking zone indicator control will begin to flash.

- Touch the appropriate sensor control on the numerical keybank for the power level you want.

Switching off a cooking zone/ the cooktop

- To switch off a cooking zone, touch the relevant cooking zone indicator.

The cooking zone indicator control will begin to flash.

- Touch the 0 sensor control on the numerical keybank.
- To switch off the cooktop and all the cooking zones, touch the ① sensor.

Operation

Residual heat indicator

If a cooking zone is still hot, the residual heat indicator will light up after it has been switched off.

The lines of the residual heat indicator go out one after another as the cooking zone cools down. The last horizontal line only goes out when the cooking zone is safe to touch.

The residual heat indicators will flash in the event of a power cut either during operation or whilst there is still danger from residual heat.



Risk of burning on hot cooking zones!

The cooking zones will be hot after use.

Do not touch the cooking zones while the residual heat indicators are on.

Setting the power level - extended setting range

- Touch one of the number sensors.

The power level selected flashes in the display for a few seconds to start with and then lights up constantly. The intermediate setting will be represented by an illuminated dot next to the number.

Extension

If you switch a double or triple cooking zone on, the second heating element is always switched on automatically. The second heating element of an extended cooking zone and the third heating element of a triple zone must be manually switched on.

On cooktops with a multi-circle cooking zone/extended zone, the indicator light to show that it is switched on lights up constantly. On cooktops with two or more multi-circle cooking zones/extended zones the indicator light to show that these are switched on only lights up whilst the cooking zone display is flashing. There is no difference in the display between the second and the third heating zone of a three circle cooking zone.

Switching a heating element off

- Briefly touch the cooking zone indicator for the required cooking zone.

The cooking zone indicator starts to flash and the indicator for the extended outer zone lights up.

- While the cooking zone indicator is flashing, touch the  sensor repeatedly until the indicator light for the extended outer zone goes out.

Switching the extended heating zone on

- Briefly touch the indicator for the required cooking zone.

The cooking zone indicator will begin to flash.

- Touch the  sensor whilst the cooking zone indicator is flashing.

The indicator light for the extended outer zone will light up.

- Set the required power level.

Operation

Auto heat-up

When Auto heat-up has been activated, the cooking zone switches on automatically at the highest setting and then switches to the continued cooking setting which you have previously selected. The heat-up time depends on which continued cooking setting has been chosen (see chart).

Activating Auto heat-up

- Briefly touch the indicator for the required cooking zone.
- Touch the sensor control for the continued cooking setting you want until a tone sounds and *H* lights up in the cooking zone display.

The *H* symbol flashes alternately with the selected power level in the cooking zone display during the heat-up time (see chart).

Changing the continued cooking setting while the cooking zone is heating up deactivates Auto heat-up.

Deactivating Auto heat-up

- Briefly touch the indicator of the required cooking zone.
- Touch the continued cooking setting you have set until *H* goes out.

Or

- Set a different power level.

Continued cooking level*	Heat-up time [min:sec]
1	1:20
1.	2:00
2	2:45
2.	3:25
3	4:05
3.	4:45
4	5:30
4.	6:10
5	6:50
5.	7:10
6	1:20
6.	2:00
7	2:45
7.	2:45
8	2:45
8.	2:45
9	–

* The continued cooking settings with a dot after the number are only available if the power level range has been extended (see "Programming"). As the higher continued cooking settings are generally used for frying food, only a relatively short heat-up time is needed to heat up the pan initially.

The cooktop has to be switched on if you wish to use the timer.
You can set a time up to a maximum of 99 minutes.

The timer can be used for the following 2 functions:

- For setting the minute minder
- For automatically switching a cooking zone off

Minute minder

Setting the minute minder

Example: You want to set a time of 15 minutes.

- Make sure the cooktop is switched on.

- Touch the timer display.

00 will flash in the timer display.

First the tens digit is set, then the units digit.

- Touch the number sensor which corresponds to the tens position (1 in this case).

The timer display then changes and 1 appears on the right.

- Touch the number sensor which corresponds to the units position (5 in this case).

The timer display will change. The 1 moves to the left and 5 appears on the right.

The minute minder will begin to count down.

Changing the time set for the minute minder

- Touch the timer display.
- Set a new minute minder time, as described above.

Cancelling the minute minder duration

- Touch the timer display until 00 appears.

Timer

Switching off a cooking zone automatically

You can set a time after which the cooking zone will switch off automatically. This function can be used on all zones at the same time.

If the time programmed is longer than the maximum operational time allowed, the safety switch-off will switch off the cooking zone after the maximum permitted safety time has elapsed (see “Safety switch-off”).

- Select a power level for the zone you require.
- Touch the timer display repeatedly until the indicator light for this zone starts flashing.

If several cooking zones are on, the indicator lights flash in a clockwise direction, starting with the front left.

- Set the required time.
- If you want to set another cooking zone to switch off automatically, follow the same steps as described above.

If more than one switch-off time is programmed, the shortest time remaining will be displayed, and the corresponding indicator light will flash. The other indicator lights will light up constantly.

- If you want to show the time remaining for another zone which is counting down in the background, touch the timer display repeatedly until the indicator light for the zone you require flashes.

Changing the switch-off time

- Touch the timer display repeatedly until the indicator light for the required zone starts flashing.
- Set the required time.

Deleting the switch-off time

- Touch the timer display repeatedly until the indicator light for the required zone starts flashing.
- Touch $\cancel{}$ on the numerical keybank.

Using both timer functions at the same time

The minute minder and automatic switch-off functions can be used at the same time.

If you have programmed one or more switch-off times, and would like to use the minute minder as well:

- Touch the timer display repeatedly until the indicator lights of the programmed cooking zones light up constantly and **00** starts flashing in the timer display.
- Set the time as described above.

If you have set the minute minder and would like to programme one or more switch-off times as well:

- Touch the timer display repeatedly until the indicator light for the required zone starts flashing.
- Set the time as described above.

Shortly after the last entry, the timer display switches to the function with the shortest remaining time.

If you want to show the times counting down in the background:

- Touch the timer display repeatedly until
 - the indicator light for the required cooking zone flashes (automatic switch-off).
 - the timer display flashes (minute minder).

Starting with the shortest time remaining which is shown in the display, all cooking zones which are switched on and the minute minder are selected clockwise.

Additional functions

Stop & Go

When Stop & Go is activated, the power of all cooking zones in use is reduced to power level 1.

The power levels set for the cooking zones and the timer settings cannot be changed, the cooktop can only be switched off. The minute minder, switch-off times, and the Auto heat-up times continue to run.

When Stop & Go is deactivated, the cooking zones will operate at the power level previously selected.

If the function is not deactivated within 1 hour, the cooktop will switch off.

Activating/Deactivating

- Touch the II/▶ sensor.

Use this function when the sensors need to be cleaned quickly.

Recall

If the cooktop is switched off inadvertently during operation, this function can be used to reset all settings. For this to work, the cooktop must be switched on again within 10 seconds of being switched off.

- Switch the cooktop on again.
- Immediately after switching the cooktop on, touch one of the flashing cooking zone indicators.

Demonstration mode

This function enables the cooktop to be demonstrated in showrooms without heating up.

Activating/deactivating the demonstration mode

- Switch the cooktop on.
- Touch and hold the 0 and 2 sensor controls on the numerical keybank at the same time for 6 seconds.

In the timer display, *dE* flashes alternately with *Dn* (demonstration mode activated) or *DF* (demonstration mode deactivated) for a few seconds.

Displaying cooktop data

The model designation and software version can be displayed. There must not be any pots or pans on the cooktop.

Model number/Serial number

- Switch the cooktop on.
- Touch and hold the 0 and 4 sensor controls on the numerical keybank at the same time for 6 seconds.

Numbers appear in the timer display separated by a dash.

Example: *12 34* (Model number KM 1234) – *1 23 45 67 89* (Serial number)

Software version

- Switch the cooktop on.
- Touch and hold the 0 and 3 sensor controls on the numerical keybank at the same time for 6 seconds.

Numbers will flash on and off in the timer display:

Example: *12* flashing alternately with *3* = Software version 123.

Safety features

System lock / Safety lock

Your cooktop is equipped with a system lock and a safety lock to prevent the cooktop and the cooking zones being switched on or any settings being altered unintentionally.

The **system lock** is activated when the cooktop is switched off. If the system lock is activated, the cooktop cannot be switched on and the timer cannot be used. A set minute minder time continues to count down. The cooktop is programmed so that the system lock must be activated manually. It can be programmed to be activated automatically 5 minutes after the cooktop has been switched off (see “Programming”).

The **safety lock** is activated while the cooktop is switched on. When the safety lock is activated, the cooktop can only be operated to a limited extent:

- The cooking zones and the cooktop can only be switched off.
- A set minute minder time can be modified.

If an unavailable sensor is touched whilst the system lock or safety lock is activated *LL* will appear in the timer display for few seconds and a tone will sound.

Activating the system lock

- Touch the ⓘ sensor for 6 seconds.



The seconds can be seen counting down in the timer display. When this time has elapsed *LL* will appear in the timer display. The system lock has been activated.

Deactivating the system lock

- Touch the ⓘ sensor for 6 seconds.



LL will appear briefly in the timer display and then the seconds will count down. The system lock is deactivated once the time has elapsed.

Activating the safety lock

- Touch and hold the  and  sensors at the same time for 6 seconds.

The seconds can be seen counting down in the timer display. When this time has elapsed LL will appear in the timer display. The safety lock is activated.

Deactivating the safety lock

- Touch and hold the  and  sensors at the same time for 6 seconds.

LL will appear briefly in the timer display and then the seconds will count down. Once the time has elapsed, the safety lock is deactivated.

Safety features

Safety switch-off

Safety switch-off if the sensors are covered

Your cooktop will switch off automatically if one or several of the sensors remain covered for longer than 10 seconds, for example, by finger contact, food boiling over or by an object such as an oven glove or a tea towel. *F* will appear in the timer display for a few seconds. If the  sensor is affected, *F* will light up until the object or soiling has been removed. *F* will go out once you have removed the object or cleaned the cooktop and the cooktop will be ready to use again.

Excessive operating time

The safety switch-off mechanism is triggered automatically if a cooking zone is heated for an unusually long period of time. This time depends on the power level selected. If it has been exceeded, the cooking zone switches off and the residual heat indicator appears. If you switch the cooking zone on and off again, it is ready for operation again.

The cooktop is programmed to safety setting 0 at the factory. If required you can set a higher safety setting with a shorter maximum operating time (see chart).

Power level*	Maximum operating time [h:min]		
	Safety setting		
	0**	1	2
1	10:00	8:00	5:00
1.	10:00	7:00	4:00
2/2.	5:00	4:00	3:00
3/3.	5:00	3:30	2:00
4/4.	4:00	2:00	1:30
5/5.	4:00	1:30	1:00
6/6.	4:00	1:00	00:30
7/7.	4:00	00:42	00:24
8	4:00	00:30	00:20
8.	4:00	00:30	00:18
9	1:00	00:24	00:10

* The power levels with a dot after the number are only available if the power level range has been extended (see “Power level range”).

** Factory default setting

Overheating protection

Each zone is equipped with overheating protection (internal temperature limiter). This switches off the heating element automatically before the ceramic surface overheats. As soon as the cooking zone temperature has cooled sufficiently, heating is switched on again automatically.

The overheating protection may be triggered under the following circumstances:

- There is no cookware on the cooking zone that is switched on.
- The pot or pan being used is empty.
- The base of a pan is not sitting evenly on the cooking zone.
- The pan is not conducting heat properly.

You can tell that the overheating protection has activated because the heating element switches on and off even when the highest power level is selected.

Programming

You can adapt the programming of the cooktop to your personal needs. Several settings can be altered in succession.

After accessing programming mode, *P* (Programme) and *C* (Code) and 2 cooking zone indicators will appear in the timer display.

The programme is shown in the left hand cooking zone display, and the code in the right hand cooking zone display. From programme stage 10 the numbers appear alternately: 1 flashes alternately with 0.

Changing the programming

Calling up programming mode

- With the **cooktop switched off** press both the $\text{\textcircled{1}}$ and **II/▶** sensor controls until *PC* appears in the timer display and 2 cooking zone indicators light up.

Setting a programme

- First touch the **left-hand** cooking zone display and then touch the relevant number on the numerical keybank.

A dot will start to flash next to the number.

- While the dot is flashing, press the relevant number(s) on the numerical keybank for the programme number.

Setting the code

- First touch the **right-hand** cooking zone display and then touch the relevant number on the numerical keybank.

A dot will start to flash next to the number.

- While the dot is flashing, press the relevant number(s) on the numerical keybank for the code.

Saving the settings

- Touch the $\text{\textcircled{1}}$ sensor until the indicators go out.

Programming

Programme ¹⁾		Code ²⁾	Settings
1	Demonstration mode	0	Demonstration mode off
		1	Demonstration mode on ³⁾
3	Factory settings	0	Factory default settings not restored
		1	Factory default settings restored
4	Number of power levels	0	9 power levels
		1	17 power levels ⁴⁾
6	Confirmation tone when a sensor control is touched	0	Off ⁵⁾
		1	Quiet
		2	Medium
		3	Loud
7	Acoustic signal of the timer	0	Off ⁵⁾
		1	Quiet
		2	Medium
		3	Loud
8	System lock	0	System lock can only be activated manually
		1	System lock activated automatically
9	Maximum operating time	0	Safety setting 0
		1	Safety setting 1
		2	Safety setting 2

Programming

Programme ¹⁾		Code ²⁾	Settings
12	Sensor controls reaction speed	0	Slow
		1	Normal
		2	Fast

1) Programmes not shown here have no allocation.

2) The factory setting is shown in bold.

3) After the cooktop has been switched on *dE* appears in the timer display for a few seconds.

4) The extended power levels are shown with a dot after the number.

5) The confirmation tone of the On/Off sensor control cannot be switched off.

 Risk of burning on hot cooking zones!

The cooking zones will be hot after use.

Switch the cooktop off.

Allow the cooking zones to cool down before cleaning the cooktop.

 Risk of damage due to moisture ingress.

The steam from a steam cleaner could reach electrical components and cause a short circuit.

Do not use a steam cleaner to clean the cooktop.

The use of unsuitable cleaning agents can cause the surfaces to discolour or alter. All surfaces are susceptible to scratching.

Remove any residual cleaning agent immediately.

Never use abrasive sponges or cleaning agents.

- Clean the cooktop after every use.
- Dry the cooktop thoroughly after every cleaning to avoid limescale residue.

Unsuitable cleaning agents

To avoid damaging the surfaces of the appliance, do not use:

- washing-up liquid,
- cleaning agents containing soda, alkalines, ammonia, acids or chlorides,
- cleaning agents containing descaling agents,
- stain and rust removers,
- abrasive cleaning agents, e.g. powder cleaners and cream cleaners,
- solvent-based cleaning agents,
- dishwasher cleaner,
- oven sprays,
- glass cleaning agents,
- hard, abrasive brushes or sponges (e.g. pot scourers), or sponges which have been previously used and still contain abrasive cleaning agents,
- dirt erasers.

Cleaning and care

Cleaning the ceramic surface

 Risk of damage by pointed objects.

The seal between the cooktop and the worktop could be damaged.

The seal between the ceramic surface and the frame could be damaged.

Do not use pointed objects for cleaning.

Do not use washing-up liquid to clean the appliance. Using washing-up liquid will not remove all soiling and residues. An invisible film can develop that can lead to discolouration of the ceramic glass surface. This discolouration cannot be removed.

Clean the ceramic surface regularly with a proprietary ceramic glass cleaning agent.

- Remove any coarse soiling with a damp cloth and more stubborn soiling with a glass scraper.
- Then clean the ceramic glass surface with the Miele ceramic and stainless steel cooktop cleaner (see “Optional accessories”) or with a proprietary ceramic glass cleaner applied with paper towel or a clean cloth. Do not apply the cleaner while the cooktop is still hot, as this can result in marking. Please follow the cleaning agent manufacturer's instructions.
- Finally wipe the cooktop with a damp cloth and dry it with a soft, dry cloth.

Residues can burn onto the cooktop the next time it is used and cause damage to the glass ceramic surface. Ensure that all cleaner residues are removed.

- **Spots** caused by limescale, water and aluminium residues (spots with a metallic appearance) can be removed using the Miele ceramic and stainless steel cooktop cleaner.

 Risk of burning on hot cooking zones!

The cooking zones are hot during use.

Wear oven gloves when removing residues of sugar, plastic or aluminium foil from a hot cooktop with a glass scraper.

- Should any **sugar, plastic or aluminium foil** spill or fall onto a hot cooking zone while it is in use, first switch off the appliance.
- Then carefully scrape off these residues **immediately** whilst they are still hot, using a shielded scraper blade suitable for use on glass.
- Afterwards, clean the ceramic surface in its cooled state, as described above.

Problem solving guide

With the help of the following guide, minor faults in the performance of the appliance, some of which may result from incorrect operation, can be remedied without contacting Miele. This will save you time and money because you will not need a service call.

Please note that a call-out charge will be applied to unnecessary service visits where the problem could have been rectified as described in these operating instructions.

Problem	Possible cause and remedy
<p>The cooktop or cooking zones do not switch on.</p>	<p>There is no power to the cooktop.</p> <ul style="list-style-type: none"> ■ Check if the circuit breaker has tripped. Contact an electrician or Miele (for the minimum fuse rating, see data plate). <p>There may be a technical fault.</p> <ul style="list-style-type: none"> ■ Disconnect the appliance from the mains electricity supply for approx. 1 minute. To do this: <ul style="list-style-type: none"> – switch off at the wall socket and withdraw the plug, or – switch off at the residual current device. ■ If, after switching the circuit breaker or residual current device back on, the appliance will still not switch on, contact a qualified electrician or Miele.
<p>A smell and vapours are given off when the new appliance is being used.</p>	<p>The metal components have a protective coating which when heated for the first time will give off a slight smell and possibly some vapours. The smell and any vapours given off do not indicate a faulty connection or appliance and they are not harmful to health.</p>
<p>After the cooktop has been switched on <i>LC</i> appears in the timer display for a few seconds.</p>	<p>The system lock or safety lock is activated.</p> <ul style="list-style-type: none"> ■ Deactivate the system lock or safety lock (see “Safety features - System lock /Safety lock”).
<p><i>F</i> flashes in the timer display and the cooktop switches off automatically.</p>	<p>One or more of the sensor controls are covered, e.g. by finger contact, food boiling over or an object.</p> <ul style="list-style-type: none"> ■ Clean off any dirt and/or remove the object (see “Safety switch-off”).

Problem solving guide

Problem	Possible cause and remedy
<p>After the cooktop has been switched on dE appears in the timer display for a few seconds. The cooking zones do not heat up.</p>	<p>The cooktop is in Demonstration mode.</p> <ul style="list-style-type: none"> ■ Touch the 0 and 2 sensor controls at the same time until dE flashes alternately with OFF in the timer display.
<p>A cooking zone switches itself off automatically.</p>	<p>It has been operated for too long.</p> <ul style="list-style-type: none"> ■ You can use the cooking zone again by switching it back on (see “Safety features - Safety switch-off”).
<p>The food in the pan hardly heats up or does not heat up at all when the Auto heat-up function is switched on.</p>	<p>There is too much food in the pan.</p> <ul style="list-style-type: none"> ■ Start cooking at the highest power level and then turn down to a lower one manually later on.
	<p>The pan is not conducting heat properly.</p> <ul style="list-style-type: none"> ■ Use a different pan which is better able to conduct heat.
<p>The food in the pan is barely heating up or is not heating up at all.</p>	<p>The pan is not conducting heat properly.</p> <ul style="list-style-type: none"> ■ Use a different pan which is better able to conduct heat.
	<p>The pan is too large for the cooking zone.</p> <ul style="list-style-type: none"> ■ Use a smaller pan.
	<p>The outer ring of a double or extended cooking zone is not switched on.</p> <ul style="list-style-type: none"> ■ Switch the outer ring on.
<p>The heating element for one of the cooking zones switches on and off.</p>	<p>This “timing” of the element is normal. It is caused by the electronic temperature control (see “How the cooking zones work”).</p> <p>If the heating switches on and off at the highest power level, the overheating protection has been triggered (see “Overheating protection”).</p>
<p>One or several residual heat indicators is flashing.</p>	<p>There was a power failure during operation or when residual heat was present.</p>

Problem solving guide

Problem	Possible cause and remedy
The sensor switches show increased sensitivity or fail to react.	<p>The sensitivity level of the sensor switches has changed.</p> <ul style="list-style-type: none">■ Make sure that there is no direct light (from the sun or from an artificial source) falling onto the cooktop. The area surrounding the cooktop must not be too dark.■ Make sure that there is nothing covering the sensors or the cooktop. Take any pans off the cooktop and wipe away any food deposits.■ Interrupt the power supply to the cooktop for approx. 1 minute.■ If the problem persists after power is restored, please contact Miele.

Optional accessories

Miele offers a range of useful accessories, as well as cleaning and conditioning products for your appliance.

These products can be ordered from the Miele online shop.

They can also be ordered directly from Miele (see end of this booklet for contact details).

Cleaning and care products

Original Miele ceramic and stainless steel cooktop cleaner 250 ml



Removes heavy soiling, limescale deposits and aluminium residues.

Original Miele all purpose microfibre cloth

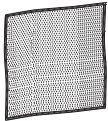

Removes finger marks and light soiling.

Safety instructions for installation

 Risk of damage from incorrect installation.
Incorrect installation can cause damage to the cooktop.
The cooktop must only be installed by a qualified person.

 Danger of electric shock!
Incorrect connection to the power supply may result in an electric shock.
The cooktop must be connected to the power supply by a qualified electrician.

 Damage from falling objects.
Take care not to damage the cooktop when fitting wall units or a rangehood above it.
Fit the wall units and the rangehood before the cooktop.

- ▶ The veneer or laminate coatings of worktops (or adjacent kitchen units) must be treated with 100 °C heat-resistant adhesive which will not dissolve or distort. Any splashbacks must be of heat-resistant material as well.
- ▶ The cooktop must not be installed over a fridge, fridge-freezer, freezer, dishwasher, washing machine, washer-dryer or tumble dryer.
- ▶ After installation, ensure that nothing can come into contact with the connection cable and that it is without hindrance.
- ▶ The connection cable may not come into contact with any moving kitchen component (e.g. a drawer) or be subject to mechanical obstruction which could damage it.
- ▶ Carefully observe the safety clearances listed on the following pages.

Safety distances

Safety distance above the cooktop

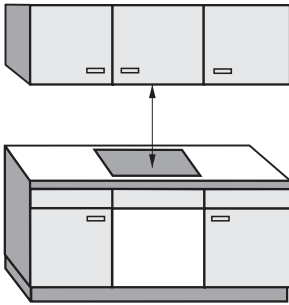

The safety distance specified by the manufacturer of the rangehood must be maintained between the cooktop and the rangehood above it.

For any flammable objects, e.g. utensil rails, wall units etc., a minimum safety distance of 600 mm must be maintained between these objects and the highest part of the cooktop below.

When two or more appliances which have different safety distances are installed together below a rangehood, observe the greatest specified safety distance.

Safety distances to the sides and back of the appliance

The minimum distance shown below must be maintained between the back edge of the cooktop and a tall unit or wall.

Ideally the cooktop should be installed with plenty of space on either side. There may be a wall at the rear or a tall unit or wall on one side (right or left), taking into account the distances below. On the other side, however, no tall unit or wall should stand closer than 300 mm to the edge of the cooktop. Before installing the cooktop, check that the below clearance requirements are met.

Minimum horizontal distance from the **back edge** of the cooktop to a combustible surface:
50 mm.

Minimum distance on the **right** side between the worktop cut-out and the closest adjacent piece of furniture (e.g. tall unit) or a room wall:

50 mm KM 6522/6527

70 mm KM 6520/6521

Minimum horizontal distance from the **left edge** of the cooktop to a vertical surface:

50 mm KM 6520/6521/6522

70 mm KM 6527

Interim shelf

It is not necessary to fit an interim shelf underneath the cooktop but one may be fitted if you wish.

If an interim shelf is fitted under the cooktop, there must be a minimum gap of 110 mm between the top of the worktop and the top of the shelf.

Leave a gap of 10 mm at the back of the shelf to accommodate the cable. If the cooktop has an external mains connection box, the minimum gap is 30 mm.

Installation notes

Installation of surface-mounted appliances

Seal between the cooktop and the worktop

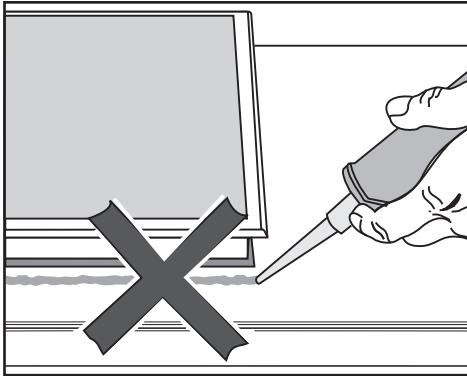

 Damage caused by incorrect installation.

Using sealant under the cooktop could result in damage to the cooktop and the worktop if the cooktop ever needs to be removed for servicing.

Do not use sealant between the cooktop and the worktop.

The sealing strip under the edge of the cooktop provides a sufficient seal for the worktop.

Tiled worktop

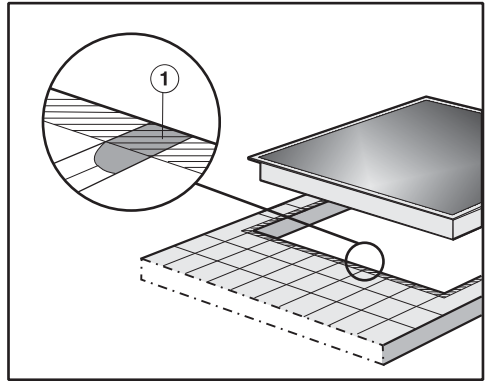

Grout lines ① and the hatched area underneath the cooktop frame must be smooth and even. If they are not, the cooktop will not sit flush with the worktop and the sealing strip underneath the cooktop will not provide a good seal between the cooktop and the worktop.

Flush-mounted installation

Flush-mounted installation is only possible in natural stone (granite, marble), solid wood and tiled worktops. Certain models are suitable for building into glass worktops - please see the relevant label on the cooktop. When using a worktop made from any other material, please check first with the worktop manufacturer that it is suitable for installing a flush-mounted cooktop.

The internal width of the base unit underneath the appliance must be at least as wide as the inner worktop cut-out (see “Building-in dimensions - Flush-mounted cooktops”), so that the cooktop is easily accessible from underneath after installation and the bottom half of the casing can be removed for maintenance. If the underside of the cooktop is not freely accessible after installation, any sealant used to plug the gaps around the appliance must be removed to enable the cooktop to be lifted out of the cut-out should this be necessary.

Natural stone worktops

The cooktop is placed directly in the cut-out.

Solid wood worktops, tiled worktops, glass worktops

The cooktop is placed on a wooden frame inside the cut-out. The frame must be provided on site and is not supplied with the appliance.

Installation dimensions – Surface-mounted

All dimensions in this instruction booklet are given in mm.

KM 6520 FR

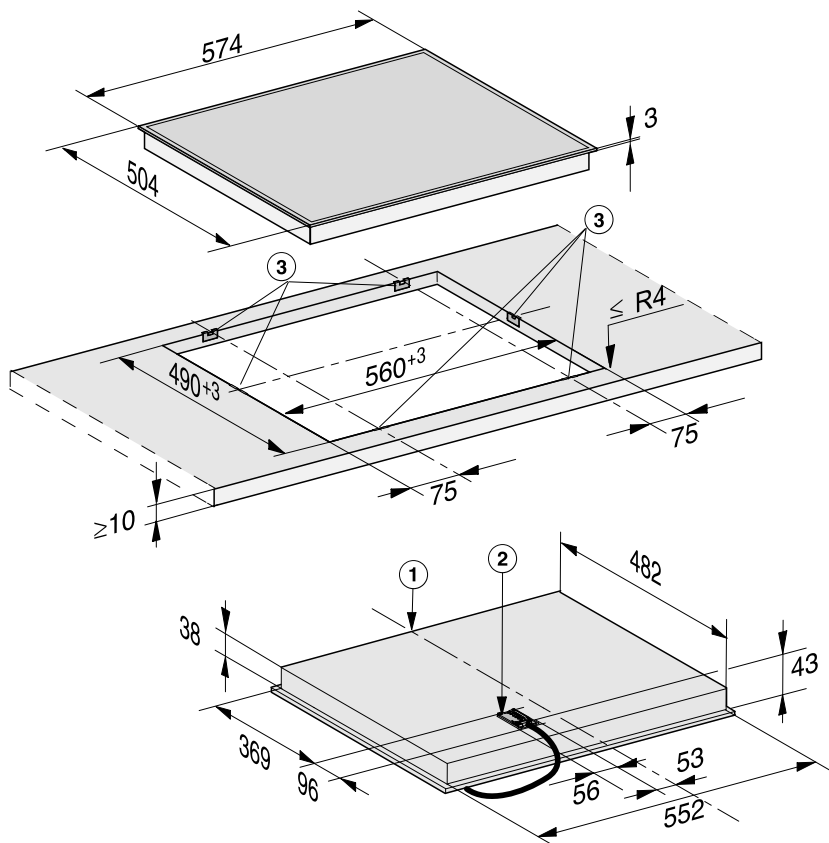

- ① Front
- ② Mains connection box with mains connection cable
Mains connection cable L = 1440 mm
- ③ Spring clips

Installation dimensions – Surface-mounted

KM 6522 FR

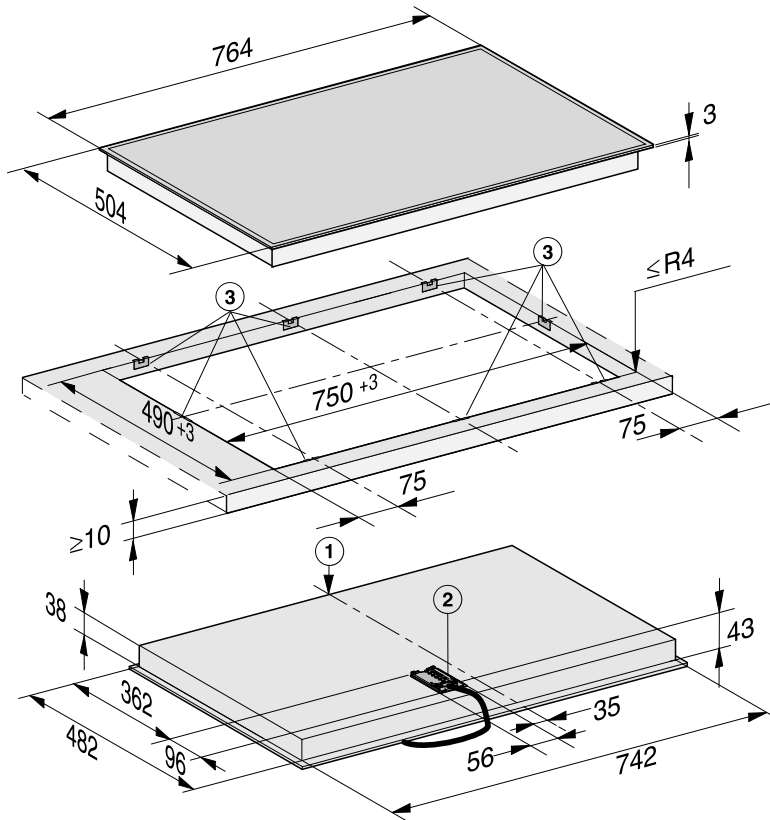

- ① Front
- ② Mains connection box with mains connection cable
Mains connection cable L = 1440 mm
- ③ Spring clips

Installation dimensions – Surface-mounted

KM 6527 FR

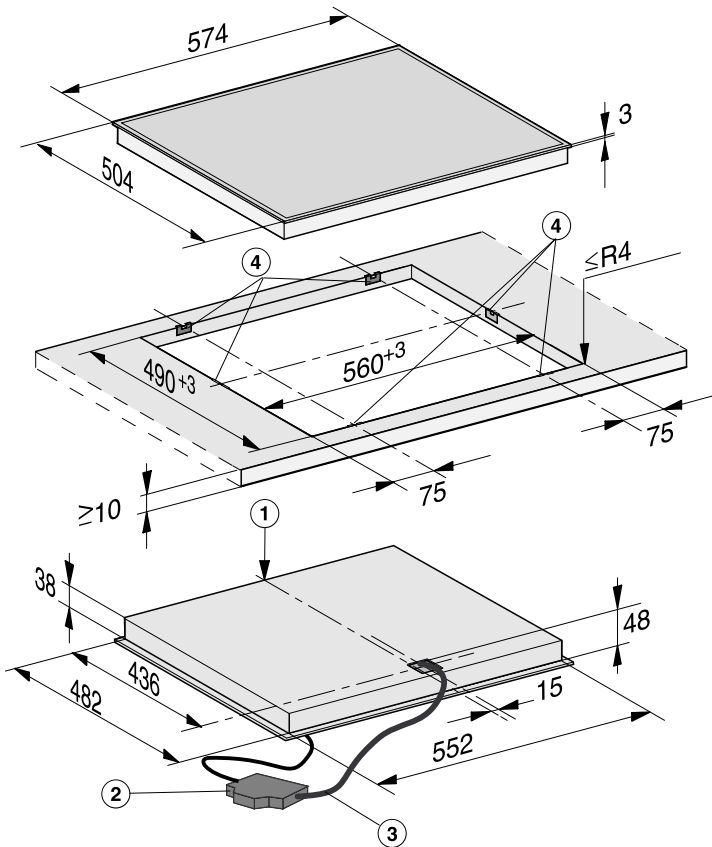

- ① Front
- ② Mains connection box with mains connection cable
Mains connection cable L = 1440 mm
- ③ Wiring harness, L = 1550 mm
- ④ Spring clips

Installation dimensions – Flush

All dimensions in this instruction booklet are given in mm.

KM 6520 FL

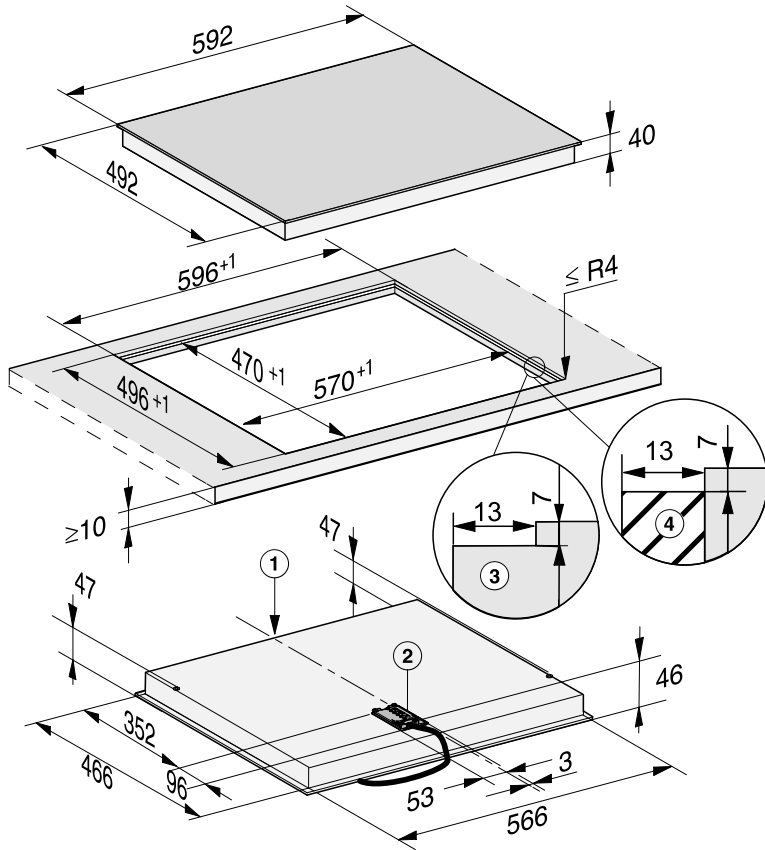

- ① Front
- ② Mains connection box with mains connection cable
Mains connection cable L = 1440 mm
- ③ Stepped cut-out, natural stone worktop
- ④ Wooden strip 13 mm (not supplied)

Installation

Installation of surface-mounted appliances

Preparing the worktop

- Create the worktop cut-out.
Remember to maintain the minimum safety distances (see “Safety distances”).

Wooden worktops

- Seal the cut surfaces with a suitable heat-resistant sealant to avoid swelling caused by moisture. The sealant must be temperature-resistant.

Make sure the sealant does not come into contact with the top surface of the worktop.

The sealing strip ensures that the cooktop will sit securely in the cut-out without slipping. Any gap between the trim and worktop will become smaller over time.

Securing the spring clips

The exact positioning of the spring clips is shown in the individual cooktop diagrams.

Wooden worktops

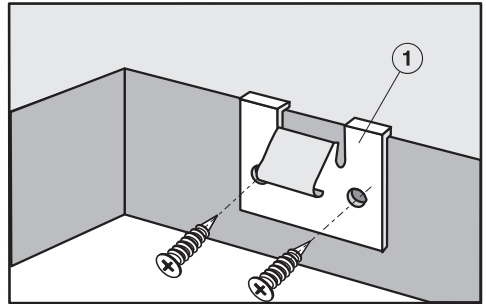

- Position the spring clips ① on the top edge of the cut-out as shown in the cooktop illustration.
- Fasten the spring clips ① using the 3.5 x 25 mm wood screws supplied with the appliance.

Granite and marble worktops

You will need heavy duty double-sided adhesive tape (not included with the cooktop) to fasten the spring clips.

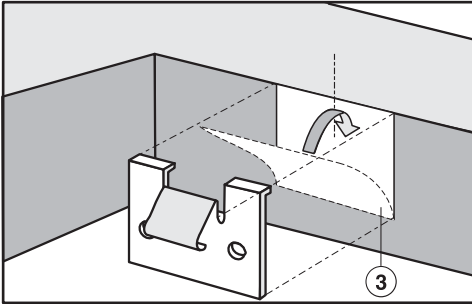

- Attach the adhesive tape ③ along the top edge of the cut-out in the positions shown in the cooktop illustration.
- Position the spring clips on the top edge of the cut-out and press them firmly into place.

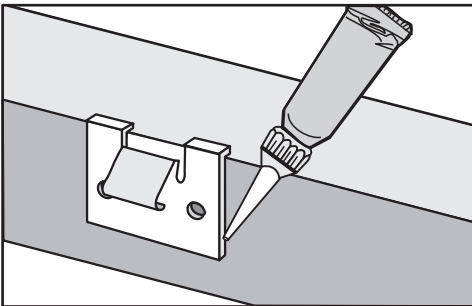

- Apply silicone adhesive to the side edges and bottom edge of the spring clips.

Installing the cooktop

- Feed the mains connection cable down through the cut-out.
- Position the cooktop in the worktop cut-out.
- Using both hands, press down evenly on the sides of the cooktop until it clicks into position. When doing this make sure that the seal of the appliance sits flush with the worktop on all sides. This is important to ensure an effective seal all round.

If the seal does not meet the worktop correctly on the corners, the corner radii ($\leq R4$) can be carefully scribed to suit.

Do not use any additional sealant (e.g. silicone).

- Connect the cooktop to the mains electricity supply.
- Check that the cooktop works.

The cooktop can only be removed using a special tool.

Installation

Flush-mounted installation

- Create the worktop cut-out.
Remember to maintain the minimum safety distances (see “Safety distances”).
- Solid wood, tiled and glass worktops:
Fix a wooden frame 7 mm below the top edge of the worktop (see “Building-in diagram - Flush-mounted installation”).
- Attach the sealing strip provided underneath the edge of the cooktop.
- Feed the mains connection cable down through the cut-out.
- Centre the cooktop in the cut-out.

The gap between the ceramic surface and the worktop must be at least 2 mm wide. This is required so that the cooktop can be sealed.

- Connect the cooktop to the mains electricity supply.
- Check that the cooktop works.
- Seal the gap between the cooktop and worktop with a silicone sealant that is heat-resistant to at least 160 °C.

 Damage caused by unsuitable sealant.

Unsuitable sealant can damage natural stone.

For natural stone worktops and natural stone tiles, only use silicone sealant that is specially formulated for natural stone. Please follow the manufacturer's instructions.

 Risk of damage from incorrect connection.

Incorrect installation, maintenance and repairs can be dangerous to users.

Miele cannot be held liable for damage or injury caused by unauthorised installation, maintenance or repair work, or by an inadequate or faulty on-site earthing system (e.g. electric shock).

The cooktop must be connected to the power supply by a qualified electrician.

The electrician must be familiar with and comply with the national regulations and any additional regulations of the local electricity provider.

After installation, ensure that all electrical components are shielded and cannot be accessed by users.

Total power output

See data plate.

Connection data

The connection data is quoted on the data plate. Please ensure this information matches the household mains supply.

Please see the wiring diagrams for connection.

Residual current device

For extra safety, it is advisable to protect the appliance with a suitable residual current device (RCD) with a trip range of 30 mA.

Disconnecting devices

Connection must be made via a suitable isolator switch which provides disconnection on all poles and which complies with national and local safety regulations. When switched off there must be an all-pole contact gap of at least 3 mm in the isolator switch. The isolator switch must be easily accessible after the appliance has been built in.

Electrical connection

Mains connection cable

The cooktop must be connected to the electrical supply with a special connection cable, type H 05 VV-F (PVC insulated) with a suitable diameter.

Please see the wiring diagram for connection.

See the data plate on the cooktop for the correct voltage and frequency.

Replacing the mains connection cable

⚠ Danger of electric shock!
Incorrect connection to the electricity supply may result in an electric shock.

The mains connection cable must only be replaced by a suitably qualified and competent person in accordance with current local and national safety regulations in order to avoid a hazard.

When replacing the mains connection cable, it must be replaced with cable type H 05 VV-F with a suitable cross-section. These cables are available from Miele.

Wiring diagram

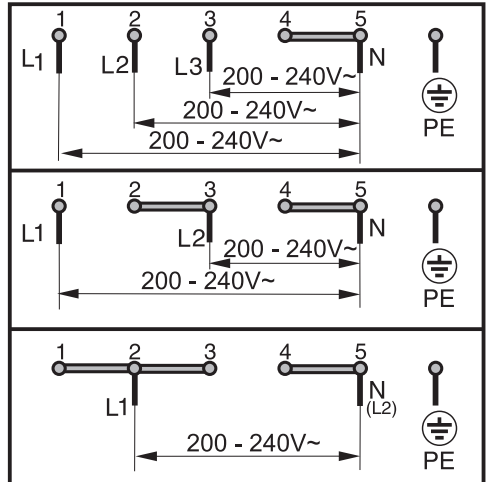

Contact in case of fault

In the event of any faults which you cannot remedy yourself, please contact Miele.

Contact information for Miele can be found at the end of this booklet.

Please quote the model and serial number of your appliance when contacting Miele. This information can be found on the data plate.

Data plate

Adhere the extra data plate supplied with the appliance in the space below. Make sure that the model number matches the one specified on the back cover of this document.

Warranty

The manufacturer's warranty for this appliance is 2 years.

For further information, please refer to your warranty booklet.

Miele Australia Pty. Ltd.

ACN 005 635 398

ABN 96 005 635 398

Miele Experience Centre and Head Office Melbourne:

1 Gilbert Park Drive
Knoxfield, VIC 3180

Miele Experience Centre South Melbourne:

206-210 Coventry Street
South Melbourne, VIC 3205

Miele Experience Centre and Office Sydney:

3 Skyline Place
Frenchs Forest, NSW 2086

Miele Experience Centre and Office Brisbane:

Tenancy 4C, 63 Skyring Terrace
Newstead, QLD 4006

Miele Experience Centre Gold Coast:

131 Ferry Road
Southport, QLD 4215

Miele Experience Centre and Office Adelaide:

83-85 Sir Donald Bradman Drive
Hilton, SA 5033

Miele Experience Centre and Office Perth:

205-207 Stirling Highway
Claremont, WA 6010



www.miele.com.au

Miele

Miele New Zealand Limited

IRD 98 463 631

Head Office:

Level 2, 10 College Hill
Freemans Bay, Auckland 1011

Miele Experience Centre Auckland:

8 College Hill
Freemans Bay, Auckland 1011
Telephone:
0800 464 353 (0800 4 MIELE)
www.miele.co.nz

Miele Global Headquarters

Germany

Miele & Cie. KG

Carl-Miele-Straße 29
33332 Gütersloh
Federal Republic of Germany

KM 6520 FR, KM 6520 FL, KM 6522 FR, KM 6527 FR

en-AU, NZ

M.-Nr. 11 007 620 / 00