



Water Softening system

Safety Information2

Installation Instructions ...3-12
 Step-by-step instructions6-12

Operating Instructions
 Breaking a salt bridge14
 Cleaning the nozzle and
 venturi assembly14
 Features15
 Service13, 16-18
 Water softener system16-18

Care and Cleaning19

Troubleshooting Tips20-22

Consumer Support
 Consumer SupportBack Cover
 Parts list/catalog23-26
 Warranty27

Water Softening System

Owner's Manual & Installation Instructions

Models GNSF35Z

Write the model and serial numbers here:

Model # _____

Serial # _____

You can find them on the back of the control head.

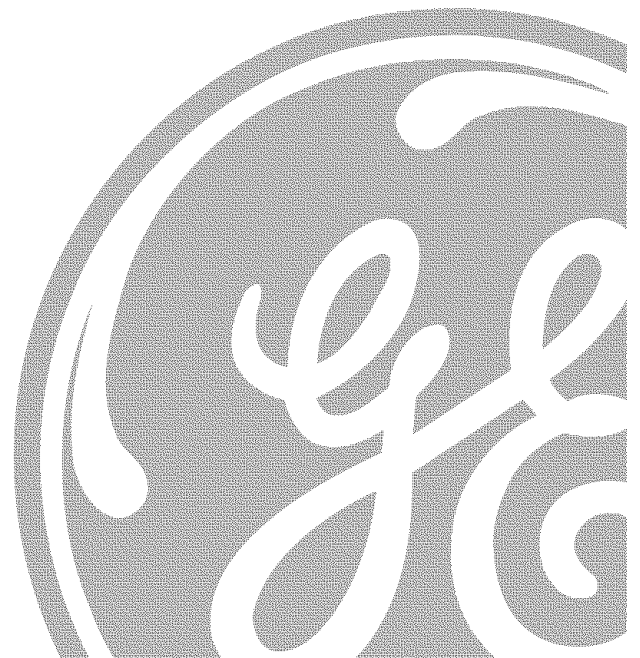

IMPORTANT SAFETY INFORMATION. READ ALL INSTRUCTIONS BEFORE USING.

⚠ WARNING!

For your safety, the information in this manual must be followed to minimize the risk of electric shock, property damage or personal injury.



SAFETY PRECAUTIONS

- Check and comply with your state and local codes. You must follow these guidelines.
- Use care when handling the water softening system. Do not turn upside down, drop, drag or set on sharp protrusions.
- Water softening systems using sodium chloride (salt) for recharge add sodium to the water. *Persons on sodium restricted diets should consider the added sodium as part of their overall intake. Potassium chloride can be used as an alternative to sodium chloride in your softener.*
- The water softening system works on 24 volt-60 Hz electrical power only. *Be sure to use only the included transformer.*
- Transformer must be plugged into an indoor 120 volt, grounded outlet only.
- Use clean water softening salts only, at least 99.5% pure. NUGGET, PELLET or coarse SOLAR salts are recommended. Do not use rock, block, granulated or ice cream making salts. They contain dirt and sediments, or mush and cake, and will create maintenance problems.
- Keep the salt hole cover in place on the softener unless servicing the unit or refilling with salt.

⚠ WARNING: Do not use with water that is microbiologically unsafe or of unknown quality without adequate disinfection before or after the system.

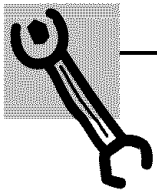

PROPER INSTALLATION

This water softening system must be properly installed and located in accordance with the Installation Instructions before it is used.

- Install or store where it will not be exposed to temperatures below freezing or exposed to any type of weather. Water freezing in the system will break it. Do not attempt to treat water over 100°F.
- **Do not** install in direct sunlight. Excessive sun or heat may cause distortion or other damage to non-metallic parts.
- Properly ground to conform with all governing codes and ordinances.
- Use only *lead-free solder and flux* for all sweat-solder connections, as required by state and federal codes.
- The water softening system requires a minimum water flow of three gallons per minute at the inlet. Maximum allowable inlet water pressure is 125 psi. If daytime pressure is over 80 psi, nighttime pressure may exceed the maximum. Use a pressure reducing valve to reduce the flow if necessary.
- Softener resins may degrade in the presence of chlorine above 2 ppm. If you have chlorine in excess of this amount, you may experience reduced life of the resin. In these conditions, you may wish to consider purchasing a GE point-of-entry household filtration system with a chlorine reducing filter.

⚠ WARNING: Discard all unused parts and packaging material after installation. Small parts remaining after the installation could be a choke hazard.



READ AND FOLLOW THIS SAFETY INFORMATION CAREFULLY.
SAVE THESE INSTRUCTIONS

Installation Instructions

Water Softening System

Model GNSF35Z

? Questions? Call 800.GE.CARES (800.432.2737) or Visit our Website at: ge.com

⚠ WARNING: Read entire manual. Failure to follow all guides and rules could cause personal injury or property damage.

- Check with your state and/or local public works department for plumbing codes. You must follow their guides as you install the Water Softening system.

NOTE: Failure to comply with these installation instructions will void the product warranty, and the installer will be responsible for any service, repair or damages caused thereby.

BEFORE BEGINNING INSTALLATION

Read these instructions completely and carefully.

- **IMPORTANT** — Save these instructions for local inspector's use.
- **IMPORTANT** — Observe all governing codes and ordinances.
- **Note to Installer** – Be sure to leave these instructions with the Consumer.
- **Note to Consumer** – Keep these instructions for future reference.
- Proper installation is the responsibility of the installer.
- Product failure due to improper installation is not covered under the Warranty.
- A shutoff valve must be available or added near the installation point.

IMPORTANT INSTALLATION RECOMMENDATIONS

- In the Commonwealth of Massachusetts, Plumbing Code 248 CMR shall be adhered to. Consult with your licensed plumber.
- Use only lead-free solder and flux for all sweat-solder connections, as required by state and federal codes.
- Connect the softener to the main water supply pipe **before** or **ahead of the** water heater. **DO NOT RUN HOT WATER THROUGH THE SOFTENER.** Temperature of water passing through the softener must be less than 120°F.

IMPORTANT INSTALLATION RECOMMENDATIONS (CONT.)

- Use care when handling the softener. Do not turn upside down, drop, drag or set on sharp protrusions.
- Maximum allowable inlet water pressure is 125 psi. If daytime pressure is over 80 psi, nighttime pressure may exceed the maximum. Use a pressure reducing valve if necessary. (Adding a pressure reducing valve may reduce the flow.)
- The softener works on 24 volt-60 Hz electrical power only. Be sure to use the included transformer. Be sure the electric outlet and transformer are in an inside location to protect from moisture.
- See *Where to Install the Softener* section for more details.

⚠ WARNING: Do not use with water that is microbiologically unsafe or of unknown quality without adequate disinfection before or after the system. The water should be tested periodically to verify that the system is performing satisfactorily.

- Small parts remaining after the installation could be a choke hazard. Discard safely.

Installation Instructions

UNPACKING AND INSPECTION

Be sure to check the entire softener for any shipping damage or parts loss. Also note damage to the shipping cartons. Contact the transportation company for all damage and loss claims. The manufacturer is not responsible for damages in transit.

Small parts needed to install the softener are packaged either in a bag or on a cardboard sheet. To avoid loss of the small parts, keep them packaged until you are ready to use them. Be sure not to discard components hidden in packaging.

TOOLS AND MATERIALS REQUIRED FOR INSTALLATION

- Pliers
- Screwdriver
- Teflon tape
- Razor knife
- Two adjustable wrenches
- Additional tools may be required if modification to home plumbing is necessary.
- In and out fittings included with the softener are 1" NPT male adapters. You should maintain the same, or larger, pipe size as the water supply pipe, up to the softener inlet and outlet. Then, use the necessary adapters to connect the water supply to the 1" NPT male adapters.
- Use the included bypass valve to install the softener. The bypass valve allows you to turn off water to the softener for servicing, but still have water in the house pipes. The NPT male adapters referred to above connect to the bypass valve with the included plastic clips.
- Use appropriate fitting/pipe material (i.e., copper, brass, galvanized or CPVC) to connect the 1" NPT plastic adapters to the house plumbing.
- If additional drain hose is needed for valve and salt tank drains, it can be ordered from GE Parts at 800.626.2002, part number WS07X10004.
- If a rigid valve drain is needed to comply with plumbing codes, you can buy the parts needed to connect a 1/2" copper tubing or plastic pipe drain. See *Step 4*.
- Clean nugget or pellet water softener salt is needed to fill the brine tank. See *Step 8*.

WHERE TO INSTALL THE SOFTENER

- Place the softener as close as possible to a sewer drain, or other acceptable drain point or standpipe.
- It is recommended to keep outside faucets on hard water to save soft water and salt.
- Do not install the softener in a place where it could freeze. **Freeze damage is not covered by the warranty.**
- Do not install the softener where it would block access to the water heater or access to the main water shutoff.
- Put the softener in a place where water damage is least likely to occur if a leak develops. The manufacturer will not repair or pay for water damage.
- A 120-volt electric outlet is needed to plug in the included transformer. The softener has a 10-foot power cable. If the outlet is remote (up to 100 feet), use 18 gauge wire to connect. **Be sure the electric outlet and transformer are in an inside location, to protect from wet weather.** Be sure the outlet is unswitched to prevent accidental shutoff.
- If installing in an outside location, you must take the steps necessary to assure the softener, installation plumbing, wiring, etc., are as well protected from the elements (sunlight, rain, wind, heat, cold), contamination, vandalism, etc., as when installed indoors. **Outdoor installation is not recommended, and voids the warranty.**
- **Keep the softener out of direct sunlight.** The sun's heat may distort non-metallic parts and may damage the electronics.

Installation Instructions

PLAN HOW YOU WILL INSTALL THE SOFTENER

You must first decide how to run in and out pipes to the softener. Look at the house main water pipe at the point where you will connect the softener. Is the pipe soldered copper, glued plastic or threaded galvanized? What is the pipe size?

⚠ WARNING: Use only lead-free solder and flux to prevent lead poisoning.

See *Typical Installation Illustration*. Use this as a guide when planning your particular installation. **Be sure to direct the incoming hard water supply to the softener valve inlet fitting.** The valve is marked **IN** and **OUT**.

TYPICAL INSTALLATION ILLUSTRATION

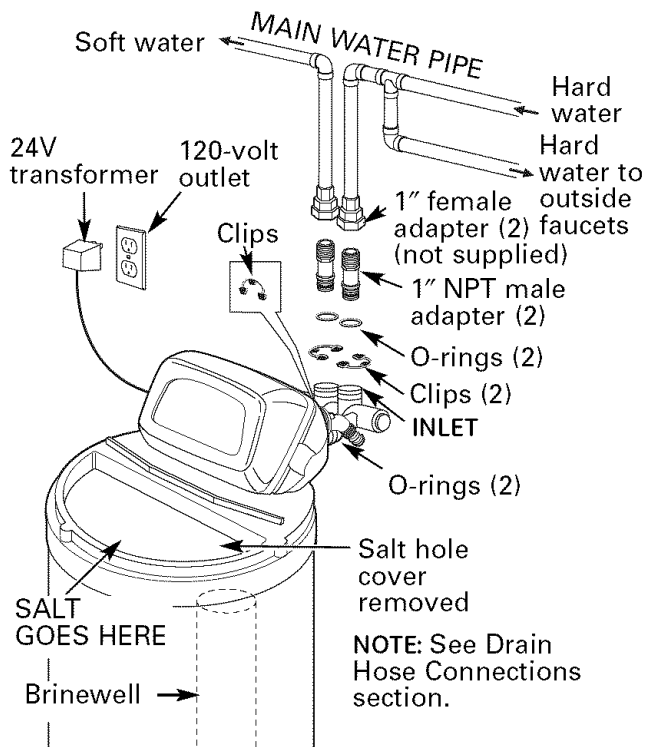

OPTIONAL 3-VALVE BYPASS INSTALLATION ILLUSTRATION

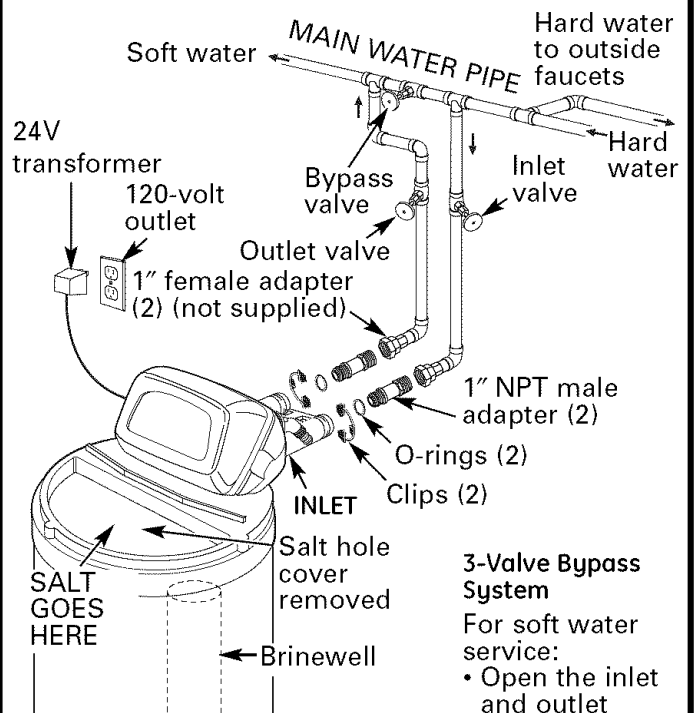

3-Valve Bypass System

For soft water service:

- Open the inlet and outlet valves
- Close the bypass valve

For bypass hard water:

- Close the inlet and outlet valves
- Open the bypass valve

Fig. 1 CROSSOVER
Use if water supply flows from the left. Include single or 3-valve bypass.

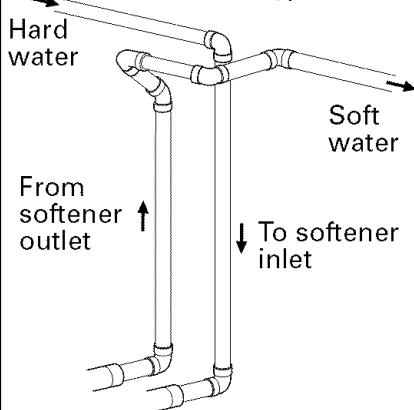
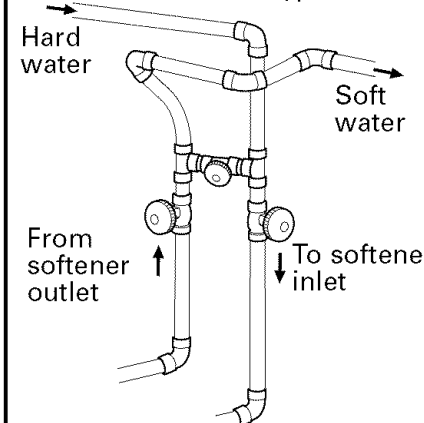

Fig. 2 CROSSOVER
Use if water supply flows from the left. Include single or 3-valve bypass.



Installation Instructions

BEFORE YOU BEGIN

- Turn off the gas or electric supply to the water heater, in the possibility that the water heater may be drained while draining pipes.
- Turn off the water supply to pipes to be cut and drain the house water pipes.
- Open both hot and cold faucets at the lowest location possible.

NOTE: For easier installation, remove the top cover. Release 2 clips at rear of cover. Rotate cover forward and lift up.

2 MOVE THE SOFTENER ASSEMBLY INTO INSTALLATION POSITION

Before sliding softener in position, be sure the installation surface is level and smooth. Sharp objects under the tank may puncture it. If needed, place the tank on a section of 3/4" thick (minimum) plywood. Then, place shims under the plywood as needed to level the softener. Slide softener into position.

1 INSTALL BYPASS VALVE

- Remove plastic shipping plug and wire from valve outlet.

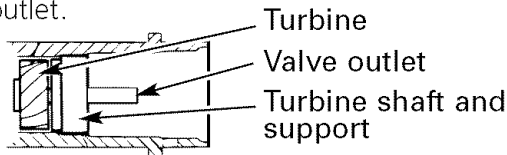

NOTE: Be sure the turbine and support are firmly in place in the valve outlet. Blow into the valve port and observe the turbine for free rotation.

- Push the bypass valve (lubricate o-ring seals with silicone grease) into both ports of the valve as shown.

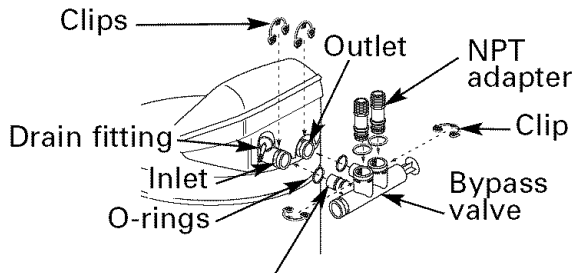

O-ring seal goes into the outer groove only. The clip snaps into the inner groove (see below).

- Snap the 2 large plastic clips in place, from the top down, as shown.

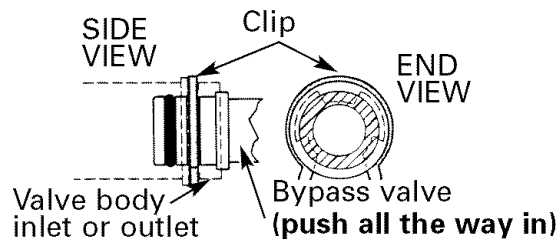

- Push the NPT adapters (lubricate o-ring seals with silicone grease) into both ports of the valve as shown.
- Snap the 2 large plastic clips in place, from the side, as shown.

Installation Instructions

3 PLUMB "IN" AND "OUT" PIPES TO AND FROM SOFTENER

CAUTION: Observe all of the following cautions as you connect inlet and outlet plumbing. See Typical Installation Illustration.

- BE SURE INCOMING **HARD WATER** SUPPLY IS DIRECTED TO THE SOFTENER VALVE **INLET** PORT. If house water flow is from the left, use a plumbing **crossover** as shown in Typical Installation Illustration. If house water flows up from the floor level, turn the bypass valve upside down as shown.

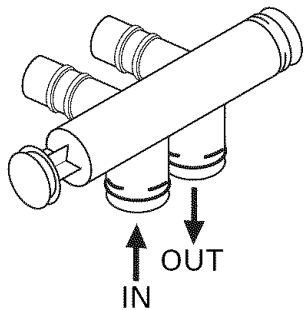

Turn bypass valve upside down to connect to floor level plumbing

- With the softener in place, determine the correct length of piping required to connect the household plumbing to the NPT male adapter.
- Remove softener from installation space.
- If making a soldered copper installation, **do all sweat soldering before connecting pipes to the NPT adapters and bypass valve.** Torch heat will damage plastic parts.
- When turning threaded pipe fittings onto plastic fittings, **use care not to cross-thread.**
- Use Teflon Tape on all external pipe threads.
- Support inlet and outlet plumbing in some manner (use pipe hangers) **to keep the weight off of the valve fittings.**
- Slide softener back into position.
- Make final connections to the bypass valve and snap clips into place.

Be sure the clips for the bypass valve and NPT adapters snap into place. Pull on the bypass valve and NPT adapters to make sure the parts are held securely in place.

4 CONNECT AND RUN THE VALVE DRAIN HOSE

- Use the provided drain hose (20' length included) to attach to the valve drain fitting. To keep water pressure from blowing the hose off, use supplied spring clamp to secure in place. Cut the necessary length and use the remainder in Step 5.
- Locate the other end of the hose at a suitable drain point (floor drain, sump, laundry tub, etc.) that terminates at the sewer. **Check and comply with local codes.**

IMPORTANT: If more drain hose is needed, it should be ordered from GE Parts at 800.626.2002, part number WS07X10004. **The water softener will not work if water cannot exit this hose during recharge.**

- Tie or wire the hose in place at the drain point. High water pressure will cause it to whip during the back-wash and fast rinse cycles of recharge. **Also provide an air gap of at least 1-1/2" between the end of the hose and the drain point.** An air gap prevents possible siphoning of sewer water into the softener, if the sewer should "back-up."

Installation Instructions

4 CONNECT AND RUN THE VALVE DRAIN HOSE (CONT.)

- Elevating the drain hose may cause back pressure that could reduce the brine draw during recharge. If raising the drain line overhead is required to get to the drain point, measure the inlet water pressure to the softener first. For inlet pressures between 20 and 50 psi, do not raise higher than 8' above the floor. For inlet pressure above 50 psi, the drain line may be raised to a maximum height of 14'.

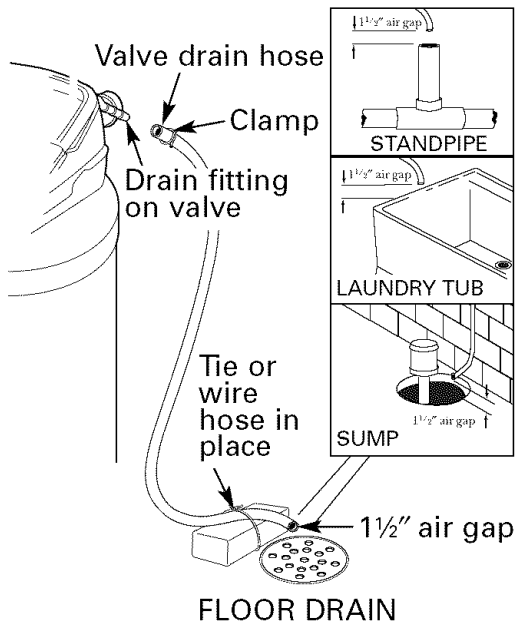

CONNECTING A RIGID VALVE DRAIN TUBE

To adapt a copper drain tube to the softener, use a hacksaw to cut the barbed end from the drain fitting as shown. Rotate the drain fitting so the cutting blade clears the valve housing to prevent damage to valve. Buy a compression fitting (1/4" female pipe thread x 1/2" O.D. tube) and needed tubing from your local hardware store.

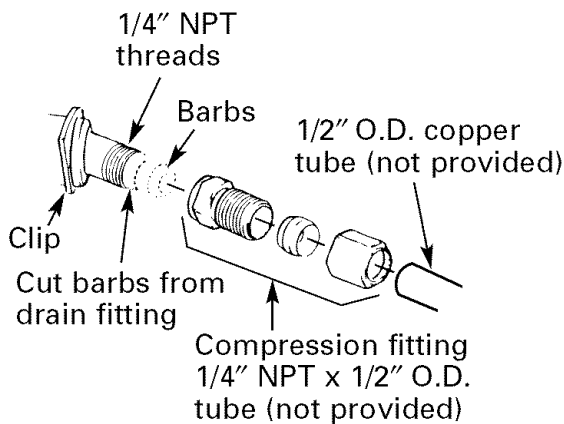

5 INSTALL THE BRINE TANK OVERFLOW FITTINGS AND HOSE

- Insert the rubber grommet into the 3/4" diameter hole in the brine tank sidewall as shown.
- Push the end of the hose adapter elbow into the grommet as shown.
- Attach a length of hose (use remaining hose from Step 4) to the hose adapter elbow. Use a hose clamp to hold it in place.
- Locate the other end of the hose at the drain point. **DO NOT ELEVATE** this hose higher than the elbow on the brine tank.

IMPORTANT: DO NOT TEE OVERFLOW HOSE TO VALVE DRAIN HOSE.

NOTE: This drain is for safety only. If the cabinet (brine tank) should over-fill with water, the excess is carried to the drain.

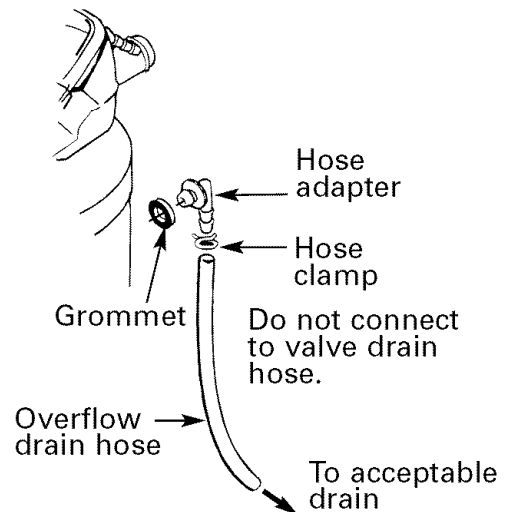

Installation Instructions

6 INSTALL GROUNDING CLAMP

⚠ DANGER: Failure to properly attach ground clamp could result in electrical shock.

If plumbing is metal, to **maintain electrical ground continuity** in the house cold water piping, install the included ground clamp as shown.

- Clean pipe with emery paper in the area where the clamp is to be installed.
- Install grounding clamps as shown, making sure clamps fit freely around pipe.
- Make sure lock washer is in place.
- Handtighten screw, then one more full turn with screwdriver.

NOTE: When replacing an existing softener, also replace grounding clamps. If removing softener completely, hard-plumb the water line with same type of pipes as the original to assure plumbing integrity and ground continuity over the life of the home.

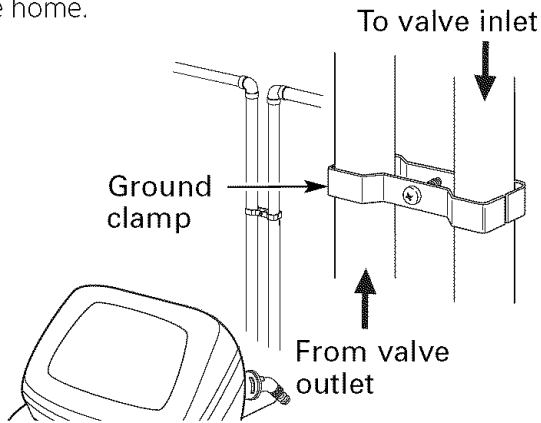

7 FLUSH PIPES, EXPEL AIR FROM SOFTENER AND TEST YOUR INSTALLATION FOR WATER LEAKS

⚠ CAUTION: To avoid water or air pressure damage to softener inner parts, be sure to do the following steps in exact order.

- Fully open 2 cold soft water faucets nearby the softener.
- Place bypass valve in “bypass” position by pushing the stem inward.
- Fully open the house main water pipe shutoff valve. Observe a steady flow from both faucets opened above.

7 FLUSH PIPES, EXPEL AIR FROM SOFTENER AND TEST YOUR INSTALLATION FOR WATER LEAKS (CONT.)

- Place bypass valve in the “service” position **EXACTLY** as follows. **KEEP SOFT WATER FAUCETS OPEN.**

SLOWLY pull or slide the valve stem (out) toward the service position, pausing several times to allow the softener to pressurize slowly.

- After about 3 minutes, open a **HOT** water faucet for 1 minute, or until all air is expelled, then close. **NOTE:** If water appears cloudy or has salty taste, allow to run for several more minutes, or until clear.
- Close all water faucets.
- Check your plumbing work for leaks and fix right away if any are found. Be sure to observe previous caution notes.
- Turn on the gas or electric supply to the water heater. Light the pilot, if applicable.

8 ADD WATER AND SALT TO THE BRINE TANK

- Lift the salt hole cover. Add about 3 gallons of water into the tank. Do not add into the brinewell.
- Fill tank with NUGGET, PELLET or coarse SOLAR water softener salt with a purity of 99.5% or higher. **Do not use** rock, block, granulated and ice cream-making salts, or **salt with iron-removing additives** (except for Diamond Crystal® Red•Out® brand salt). Maximum salt storage capacity is approximately 200 lbs. Keep the salt hole cover closed unless servicing the unit or refilling with salt.

NOTE: If the softener is installed in a humid basement or other damp area, it is better to **fill the tank with less salt, more frequently**. Eighty to 100 lbs. of salt will last for several months, depending on water hardness, family size and water softening system model.

Installation Instructions

9 CONNECT TO ELECTRICAL POWER

To gain access to the transformer/power cord assembly, remove the salt hole cover from the softener. Unclip the tabs on the rear of the top cover and rotate the cover upward to remove. **DO NOT PULL OR DISCONNECT WIRING.**

- The softener works on 24 volt-60Hz electric power. The included transformer changes standard 120-volt AC house power to 24 volts. **Plug the transformer into a 120-volt outlet only.** Be sure the outlet is always live so it can not be switched off by mistake.
- Replace the top cover.
- Replace the salt hole cover.

PROGRAMMING THE CONTROL

PROGRAMMING THE CONTROL

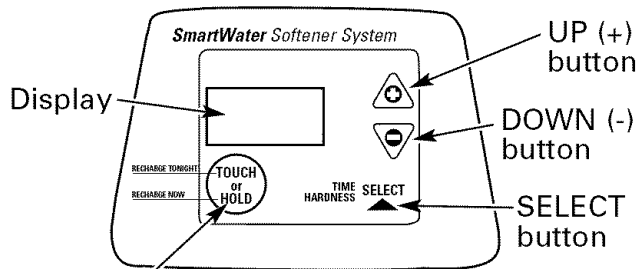

TOUCH or HOLD button

CONTROL SETTINGS REQUIRED upon installation and after an extended power outage.

NOTES:

- WHEN THE TRANSFORMER IS PLUGGED INTO THE ELECTRICAL OUTLET, 12:00 PM (flashing), and **PRESENT TIME** is displayed. Program the control as instructed below.
If **SR - - - or - - -** is flashing, use the UP ▲ button to set the correct model code as follows: **F35** for GNSF35. If you pass by the correct code number, use the DOWN ▼ button. Then press the **SELECT** button to accept the correct model.
- A “beep” sounds while pressing buttons for control programming. One beep signals a change in the control display. Repeated beeps mean the control will not accept a change from the button you have pressed, and you should select another button.
- To program the control, you will use the UP ▲, DOWN ▼ and **SELECT** buttons.
- Use the **SELECT** button to select the desired control function.

SET PRESENT TIME OF DAY

1. Press the **SELECT** button until **PRESENT TIME** appears in the display.
2. Press UP ▲ or DOWN ▼ button to set. The UP button advances the time; the DOWN button moves the time in reverse.



If the present time is between noon and midnight, be sure PM shows in the display. If the present time is between midnight and noon, be sure AM shows in the display.

- NOTE:** Each press of an UP ▲ or DOWN ▼ button changes the time by one minute. Holding the button changes the time at a rapid rate.
3. When the present time is correct, press **SELECT** to accept.

SET WATER HARDNESS NUMBER

1. Press the **SELECT** button until **HARDNESS** appears in the display.
2. Press UP ▲ or DOWN ▼ button to set your water hardness number in the display. DOWN decreases the hardness value. UP increases the hardness value.



NOTE: Each press of a button changes the display by 1, between 1 and 25. Above 25, the display changes 5 at a time (25, 30, 35, etc.). Holding a button in changes the numbers at a rapid rate.

Installation Instructions

SET WATER HARDNESS NUMBER (CONT.)

3. When the display shows your water hardness (in grains per gallon), press **SELECT** to accept.

NOTE: If there is clear water iron in your water supply, you will need to increase the hardness setting by 5 for each 1 ppm of clear water iron in your water supply.

You can get the grains per gallon (gpg) hardness of your water supply from a water analysis laboratory. If you are on a municipal supply, call your local water department. Or call Legend Technical Services, an independent laboratory, to request a water hardness test kit at 1.800.949.8220, option 4. If your report shows hardness in parts per million (ppm) or milligrams per liter (mg/l), simply divide by 17.1 to get the equivalent number of grains per gallon.

SET RECHARGE (STARTING) TIME

1. Press the **SELECT** button until **RECHARGE TIME** appears in the display.



NOTE: A flashing 2:00 AM (factory default) should show in the display. This is a good time for recharge to start (takes about 2 hours) in most households because water is not in use. HARD WATER is bypassed to house faucets during recharge.

If no change is needed, go to step 3. To change the recharge starting time, follow step 2.

2. Press UP ▲ or DOWN ▼ button to set the desired recharge start time. Be sure to observe the AM or PM as you did when setting the time of day.

NOTE: Each press of a button changes the time by 1 hour. Holding the buttons in changes the time at a rapid rate.

3. Press the **SELECT** button to accept.

OPTIONAL CONTROL SETTINGS

The controller display has several options and features.

SYSTEM/ELECTRONIC DIAGNOSTICS

This display contains system diagnostics information to assist in troubleshooting problems with the Water Softener. See page 16.

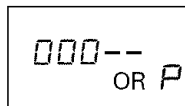

To access the System Diagnostics, press and hold the **SELECT** button for 3 seconds.

To return to the normal display, press the **SELECT** button 2 times.

SALT EFFICIENCY

When the **SALT EFFICIENCY** feature is ON, the unit will operate at a salt efficiency of at least 4000 grains of hardness removed per pound of salt. This mode of operation is the most efficient setting for salt usage, because the system will tend to recharge more often, with less salt usage. Turning the feature OFF will tend to lengthen the time between recharge cycles, which will provide the most efficient usage of water, but may use more salt. The degree of difference between these two cycles is highly dependent on the water usage and hardness at a particular installation.

NOTE: California Regulations require this feature to be ON for installations in California.

To access the Salt Efficiency, press and hold the **SELECT** button for 3 seconds. The System Diagnostics display will appear.

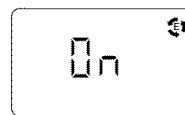

Press the **SELECT** button again and the Salt Efficiency display will appear.



To change the setting, press the UP ▲ or DOWN ▼ buttons to toggle the feature ON or OFF. Press the **SELECT** button to accept.

ERROR SIGNALS

If there is an error code detected, the display will flash **Err** to signal that the softener requires service.

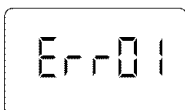

See page 16 for information to assist in troubleshooting error codes. Once the problem is corrected, disconnect the transformer from the wall outlet momentarily, and plug it back in. The normal display will appear. The motor may run for several minutes, as the unit resets. If the problem is not corrected, the error code will reappear in 8 minutes.

Installation Instructions

SANITIZING PROCEDURES

To complete the installation, do the following sanitizing procedures.

Care is taken at the factory to keep your water softener clean and sanitary. Materials used to make the softener will not infect or contaminate your water supply and will not cause bacteria to form or grow. However, during shipping, storage, installation and operation, bacteria could get into the softener. For this reason, sanitizing as follows is suggested when installing.

NOTE: Sanitizing is recommended by the Water Quality Association for disinfecting.

1. Be sure to complete all installation steps, including programming the control.
2. Pour about 3/4 oz. (1½ tablespoons) of common 5.25% unscented household bleach (Clorox, Linco, Bo Peep, White Sail, Eagle, etc.) into the **brinewell**. Refer to illustration on page 5.
3. **IMPORTANT:** Press and hold for 3 seconds the faceplate **TOUCH/HOLD** button to start an immediate recharge. The bleach will be drawn through the water softener, and out the drain. This process takes approximately 2 hours.

4. If, after sanitization, water from the house faucet tastes salty or has a slight color, this is a preservative from the resin tank. Turn on the cold soft water faucets and drain for a few minutes or until clear.

NOTE: When the sanitizing recharge is over, all remaining bleach is flushed from the conditioner and your house **COLD** water supply is fully soft immediately. However, your water heater is filled with hard water and as hot water is used, it will refill with soft water. When all the hard water is replaced in the water heater, hot only and mixed hot and cold water will be fully soft. If you want totally soft water immediately, after the above recharge, drain the water heater until the water runs cold.

▲WARNING: If you do drain the water heater, use extreme care as the hot water could cause burns. Turn the water heater off prior to draining.

SPECIFICATIONS/DIMENSIONS

	GNSF35Z
Rated capacity*	(see rating label on water softener)
Rated efficiency**	(see rating label on water softener)
Amount of high capacity resin (lbs/cu. ft)	48.9/.94
Resin tank nominal size (in., dia. x height)	9 x 40
Service flow rate (gpm)	(see rating label on water softener)
Water supply maximum hardness (gpg)	100
Water supply maximum clear water iron (ppm)***	9
Water pressure limits (min.-max. psi)****	20-125
Pressure drop at rated service flow (psig)	14
Water temperature limits (min.-max.°F)	40-120
Water supply minimum flow rate (gpm)	3
Maximum flow rate to drain (gpm)	2.2

This system conforms to NSF/ANSI 44 for the specific capacity claims as verified and substantiated by test data.

* Testing was performed using pellet grade sodium chloride as the regenerant salt.

** Efficiency rating is valid only at the lowest stated salt dosage. This softener was efficiency rated according to NSF/ANSI 44.

*** Extent of iron removal may vary with conditions. The capacity to reduce clear water iron is substantiated by WQA test data. Use of Diamond Crystal® Red•Out® or Super Iron Out® will improve iron removal. Refer to Cleaning Iron Out of the Water Softening System section.

**** Canada working pressure limits: 1.4-7.0 kg/cm².

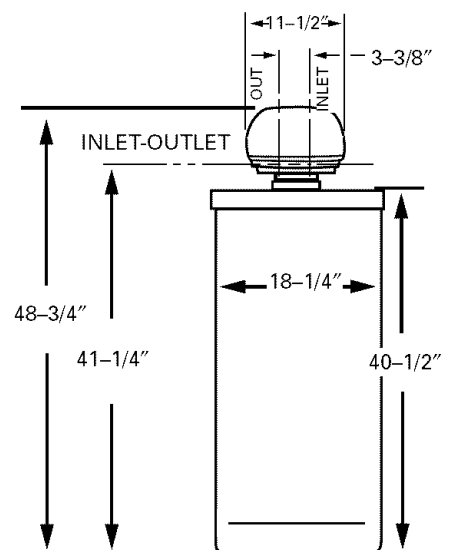

Service

When the water softening system is providing soft water, it is called "Service." During service, hard water flows from the house main water pipe into the water softening system. Inside the water softening system resin tank is a bed made up of thousands of tiny, plastic resin beads. As hard water passes through the bed, each bead attracts and holds the hard minerals. This is called ion-exchanging. It is much like a magnet attracting and holding metals. Water without hard minerals (soft water) flows from the water softening system and to the house pipes.

After a period of time, the resin beads become coated with hard minerals and they have to be cleaned. This cleaning is called recharge. Recharge is started at 2:00 AM (factory setting) by the water softening system control, and consists of five stages or cycles. These are **FILL, BRINING, BRINE RINSE, BACKWASH** and **FAST RINSE**.

Automatic Hard Water Bypass During Recharge

For emergency needs, hard water is available to the home during the recharge cycles.

However, you should avoid using HOT water because the water heater will fill with the hard water.

Fill

Salt dissolved in water is called brine. Brine is needed to clean the hard minerals from resin beads. To make the brine, water flows into the salt storage area during the fill stage.

Brining

During brining, brine travels from the salt storage area into the resin tank. Brine is the cleaning agent needed to remove hard minerals from the resin beads. The hard minerals and brine are discharged to the drain.

The nozzle and venturi create a suction to move the brine, maintaining a very slow rate to get the best resin cleaning with the least salt.

Brine Rinse

After a pre-measured amount of brine is used, the brine valve closes. Water continues to flow in the same path as during brining, except for the discontinued brine flow. Hard minerals and brine flush from the resin tank to the drain.

Backwash

During backwash, water travels **up** through the resin tank at a fast flow rate, flushing accumulated iron, dirt and sediments from the resin bed and to the drain.

Fast Rinse

Backwash is followed by a fast flow of water **down** through the resin tank. The fast flow flushes brine from the bottom of the tank, and packs the resin bed.

After fast rinse, the water softening system returns to soft water service.

About the water softener system.

Breaking a Salt Bridge

Sometimes, a hard crust or salt bridge forms in the salt storage area. It is usually caused by high humidity or the wrong kind of salt. When the salt bridges, an empty space forms between the water and salt. Then salt will not dissolve in the water to make brine.

If the brine tank is full of salt, it is hard to tell if you have a salt bridge. Salt is loose on top, but the bridge is under it. The following is the best way to check for a salt bridge.

Salt should be loose all the way to the bottom of the tank. Take a broom handle or like tool, and carefully push it down into the salt, working it up and down. If the tool strikes a hard object (be sure it's not the bottom or sides of the tank), it's most likely a salt bridge. Carefully break the bridge with the tool. **Do not** pound on the walls of the tank.

If the wrong kind of salt made the bridge, take it out. Then fill the tank with nugget or pellet salt only. In humid areas, it is best to fill with less salt, more often to prevent a salt bridge from forming.

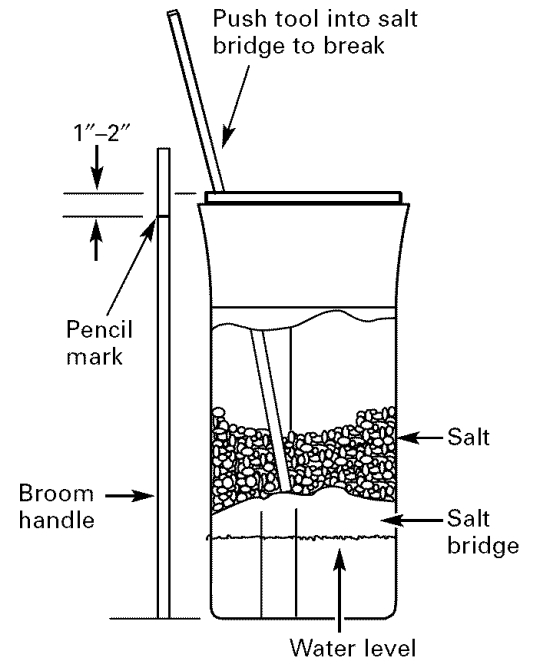

Cleaning the Nozzle and Venturi Assembly

A clean nozzle and venturi is needed for the water softening system to work properly. This small unit makes the suction to move brine from the salt storage area to the resin tank during recharge. If it becomes plugged with sand, dirt, etc., the water softening system will not work and you will get hard water.

To get to the nozzle and venturi, remove the water softening system top cover. Be sure the water softening system is in service cycle (no water pressure at nozzle and venturi). Then, while holding the nozzle and venturi housing with one hand, remove the cap. Lift out the screen support and screen, then the nozzle and venturi. Wash and rinse the parts in warm water until clean. If needed, use a small brush to remove iron or dirt. Also check and clean the gasket.

NOTE: Some models have a small flow plug located in the nozzle and venturi, and/or a small cone shaped screen in the housing. Be sure to check and clean these parts, if your model is so equipped.

Carefully replace all parts in the correct order. Lightly lubricate the o-ring seal with clean silicone grease or petroleum jelly and place in position. **Install and tighten the cap, by hand only. Do not overtighten the cap.**

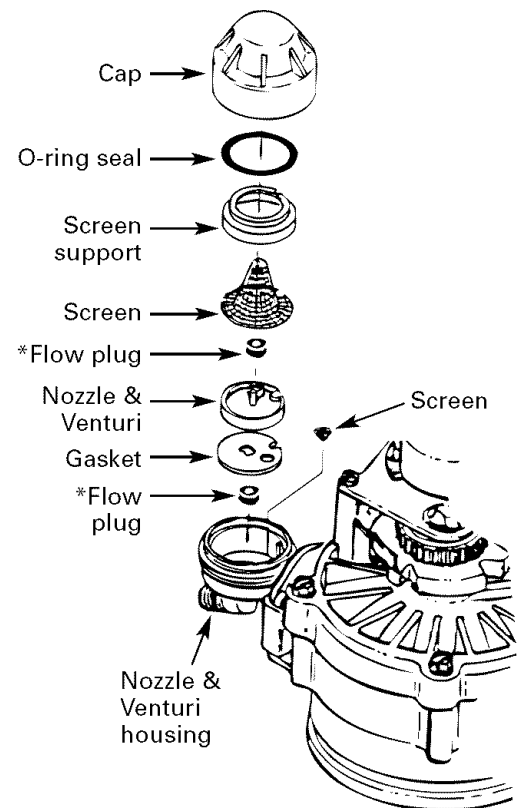

IMPORTANT: Be sure small holes in the gasket are centered directly over the small holes in the nozzle and venturi housing.

*Install with numbered side up, concave side down.

Normal Operation, Control Displays

During normal operation, the present time of day and AM or PM show in the control display area. When the demand computer determines a recharge is needed, a regeneration (recharge) begins at the next recharge start time. During a recharge, **RECHARGE NOW** flashes until the recharge is over.

Feature: Optional Recharge Controls

Sometimes, a manually started recharge may be desired or needed. *Two examples:*

- You have used more water than usual (house guests, extra washing, etc.) and you may run out of soft water before the next recharge.
- The system ran out of salt.

Use one of the following features to start a recharge immediately, or at the next preset recharge start time.

RECHARGE TONIGHT

Touch (do not hold) the **TOUCH OR HOLD** button. **RECHARGE TONIGHT** flashes in the control display area. A recharge will occur at the next preset recharge start time. If you decide to cancel this recharge, touch the same button once more.

RECHARGE NOW

Press and hold the **TOUCH OR HOLD** button until **RECHARGE NOW** starts to flash in the control display area. The water softening system begins an immediate recharge and, when over in about two hours, you will have a new supply of soft water. Once started, you cannot cancel this recharge.

Feature: Memory

If electrical power to the water softening system is interrupted, the control display is blank, and the blue indicator light is off, but the control keeps correct time for about 6 hours. When power is restored, you have to reset the present time only if the display and blue indicator light are flashing. All other settings are maintained and never require resetting unless a change is desired.

If the time is flashing after a long power outage, the water softening system continues to work as it should to provide you with soft water. However, recharge may occur at the wrong time of day until you reset the control to the correct time of day.

Feature/Service: Automatic Electronic Diagnostics

The control computer has a self-diagnostic function for the electrical system (except input power and water meter). The computer monitors the electronic components and circuits for correct operation. If a malfunction occurs, an error code appears in the control display.

The chart on *Error Codes* shows the error codes that could appear and possible reasons for each code. See *Manually Initiated Electronics Diagnostics* to further isolate the defect.

About the water softener system.

Service: Electronic Demand Time Features and Service

ERROR CODE DISPLAYED	ERR 01	ERR 02	ERR 03	ERR 04	ERR 05
POSSIBLE DEFECT	<ul style="list-style-type: none"> • Motor inoperative • Wiring harness or connection to switch • Position switch • Control 	<ul style="list-style-type: none"> • Position switch • Control 	<ul style="list-style-type: none"> • Motor inoperative or wiring harness • Control 	<ul style="list-style-type: none"> • Position switch or wiring harness • Control 	<ul style="list-style-type: none"> • Control

To remove an error code: 1. Unplug transformer.
 2. Correct defect.
 3. Plug transformer in.
 4. Wait for at least 6 minutes. The error code will return if the reason for the error code was not corrected.

Service: Timer/Softener, Service Checkout Procedure

If you are not getting soft water, and an error code is not displayed, use the procedures below to find the problem. First make the following visual checks.

VISUAL CHECKS:

1. Is there electrical power to the outlet the water softening system transformer is plugged into?

2. Is there sufficient salt in the storage tank?
3. Is the softener bypass valve directing water for soft water service?
4. Is the valve drain hose open to the drain, not more than 8' above the softener, and unobstructed? If hose is above 8', see page 8, step 4.

If you do not find a problem with the visual checks, continue below.

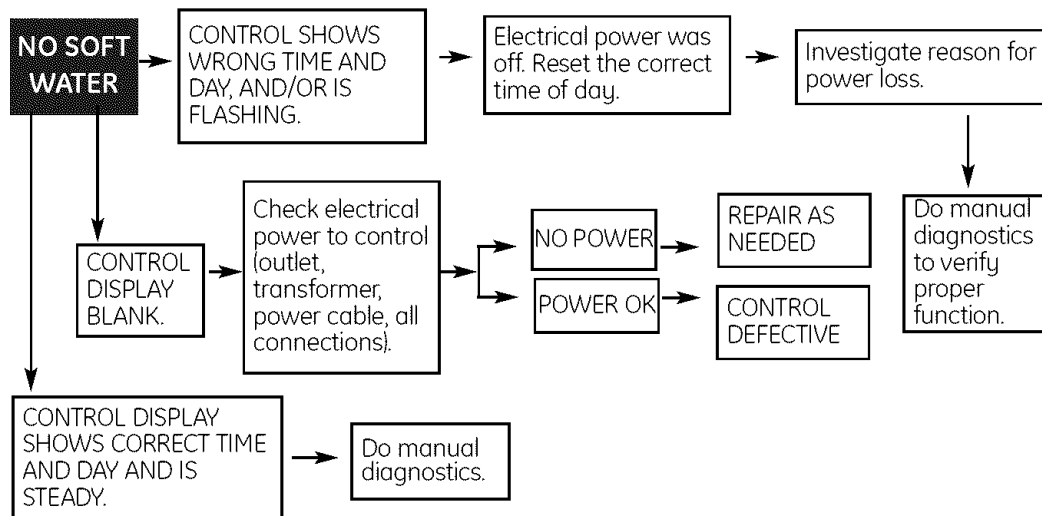

Service: Manually Initiated Electronics Diagnostics

1. To enter diagnostics, press and hold the **SELECT** button until (000 - -) shows in the display.

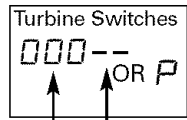

A The first 3 digits indicate water meter operation as follows:

- 000 (steady) = soft water not in use...no flow through the meter.

—OPEN A NEARBY SOFT WATER FAUCET—

- 000 to 199 (continual) = repeats display for each gallon of water passing through the meter.

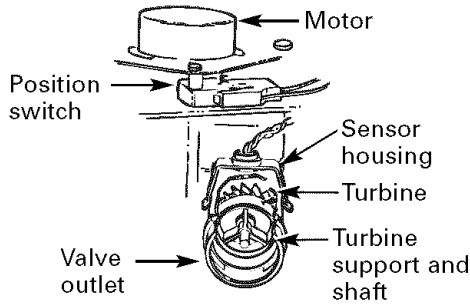

If you don't get a reading in the display, with faucet open, pull the sensor from the valve outlet port. Pass a small magnet back and forth in front of the sensor. You should get a reading in the display. If you get a reading, shut off water supply, unhook the in and out plumbing and check the turbine for binding.

B The letter (P) and dash(es) indicate **POSITION** switch operation. The letter appearing means the switch is closed; the dash means the switch is open. Use the **TOUCH OR HOLD (RECHARGE TONIGHT-RECHARGE NOW)** button to manually advance the valve into each cycle and check correct switch operation.

CORRECT SWITCH DISPLAYS	VALVE CYCLE STATUS
--	Valve in service, fill, brining, backwash or fast rinse position.
- P	Valve rotating from one position to another

C While in this diagnostic screen, the following information is available and may be beneficial for various reasons. This information is retained by the computer from the first time electrical power is applied to the control.

- Press and hold the **UP** button to display the number of days this control has had electrical power applied.
- Press and hold the **DOWN** button to display the number of regenerations initiated by this control since the SR code number was entered.

2. Press the **SELECT** button and hold in three seconds until a Service Rating code appears in the display.

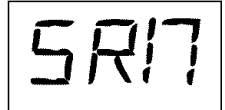

For correct water softening system operation, the model code must be F35 for model GNSF35Z.

To reset the code, press the **UP** or **DOWN** button until the correct number shows.

3. Press the **SELECT** button to return to the present time display. **If the code was changed, make ALL the timer settings.**

NOTE: If the control is left in a diagnostic display or a flashing display when setting times or hardness, present time automatically returns if a button is not pressed within four minutes.

About the water softener system.

Service: Manually Advance Regeneration Check

This check verifies proper operation of the valve motor, brine tank fill, brine draw, regeneration flow rates and other controller functions. First, make the initial checks and the *Manually Initiated Electronics Diagnostics*.

NOTE: The control display must show a steady time (not flashing).

1. Press the **TOUCH OR HOLD** button and hold in for three seconds. **RECHARGE NOW** begins to flash as the water softening system enters the fill cycle of regeneration. Remove the brinewell cover and, using a flashlight, observe fill water entering the brine tank. If water does not enter the tank, look for an obstructed nozzle, venturi, fill flow plug or brine tubing. See *Care and cleaning of the water softening system* section.
2. After observing fill, press the **TOUCH OR HOLD** button to move the water softening system into brining. A slow flow of water to the drain will begin. Verify brine draw from the brine tank by shining a flashlight into the brinewell and observing a noticeable drop in the liquid level over an extended period of time.

NOTE: Be sure a salt bridge is not preventing water from contacting salt. See *Care and cleaning of the water softening system* section.

If the water softening system does not draw brine, check:

- nozzle and/or venturi dirty or defective.
- nozzle and venturi not seated properly on gasket.
- restricted drain (check drain fitting and hose).
- defective nozzle and venturi seal.
- other inner valve defect (rotor seal, rotor and disc, wave washer, etc.).

NOTE: If water system pressure is low, an elevated drain hose may cause back pressure, stopping brine draw.

3. Again, press the **TOUCH OR HOLD** button to move the water softening system into backwash. Look for a fast flow of water from the drain hose. A slow flow indicates a plugged top distributor, backwash flow plug or drain hose.
4. Press the **TOUCH OR HOLD** button to move the water softening system into fast rinse. Again look for a fast drain flow. Allow the water softening system to rinse for a few minutes to flush out any brine that may remain in the resin tank from the brining cycle test.
5. To return the water softening system to service, press the **TOUCH OR HOLD** button.

Checking the Salt Storage Level and Refilling

Brine (salt dissolved in water) is needed for each and every recharge. The water for making brine is metered into the salt storage area by the water softening system valve and control.

However, you must keep the tank supplied with salt.

When to refill with salt: Check the salt level a few weeks after you install the water softening system and every week after that. Refill when the brine tank is from 1/3 to 1/2 full. In humid areas it is best to fill with less salt more often. Never allow the water softening system to use all the salt before you refill it. Without salt, you will soon have hard water.

Use clean water softening salts only, at least 99.5% pure. NUGGET, PELLET or coarse SOLAR salts are recommended. **Do not use rock, block, granulated or ice cream making salts.** They contain dirt and sediments, or mush and cake, and will create maintenance problems.

⚠ CAUTION: **Water softening salt with iron removing additives:** Some salts may have an additive to help the water softening system handle iron in the water supply. Although this additive may help to keep the water softening system resin clean, it may also release corrosive fumes that weaken and shorten the life of some water softening system parts. GE recommends using only Diamond Crystal® Red•Out® brand salt.

Cleaning Iron Out of the Water Softening System

Your water softening system takes hardness minerals (calcium and magnesium) out of the water. Also, it can control some (see the *Specification Guidelines* section) "clear water" iron. With clear water iron, water from a faucet is clear when first put into a glass. After 15 to 30 minutes, the water begins to cloud or turn rust colored. A water softening system **will not** remove any iron that makes the water cloudy or rusty as it comes from the faucet (called red water iron). To take red water iron out of water, or over the maximum of clear water iron, an iron filter or other equipment is needed.

GE recommends using only Diamond Crystal® Red•Out® brand salts with Iron Fighter® additive to help keep the resin bed clean of clear iron. If your water supply has clear water iron, periodic resin bed cleaning is needed. GE recommends using Super Iron Out® brand resin bed cleaner to thoroughly clean your resin bed if your iron content is high. Clean the bed at least every six months, or more often if iron appears in the soft water between cleanings.

IMPORTANT: It is important to mix the resin bed cleaner with water (following the manufacturer's instructions), pour it into the **brinewell tube** (see page 5) and recharge the softener immediately. Do not pour the resin bed cleaner in with the salt, as it will not be as effective in cleaning the resin, and can cause damage to the softener if it is left in the brine tank for an extended period due to the corrosive gases that are formed.

Before you call for service...



Troubleshooting Tips
Save time and money! Review the chart on the following pages first and you may not need to call for service.

NO SOFT WATER – Most Common Problems:

Check the following before calling for service:

- Not enough salt—should be at least 1/3 full.
- Bypass valve in “Bypass” position—knob should be in the “OUT” (service) position.
- Hardness setting too low. Check hardness setting and adjust. Verify hardness of supply water—from local water company, water test or call the GE Answer Center.
- Salt Bridge—salt solidifies above water level so that brine water is not in contact with salt. See the *Breaking a Salt Bridge* section.

Problem	Possible Causes	What To Do
No soft water	<p>Faucet or fixture where sample was taken not plumbed to soft water. <i>NOTE: Be sure sample is from a faucet that does not mix soft and hard water. For example, a single lever kitchen faucet, if the cold side is plumbed to hard water.</i></p>	<ul style="list-style-type: none"> • To conserve salt, the installer may have isolated some fixtures (outside faucets, toilets, etc.) from soft water. From the outlet of the water softening system, trace the water flow path, in house plumbing. If soft water is not directed to a faucet or fixture where wanted, consult a plumber.
	<p>No salt in the brine tank or salt bridged</p>	<ul style="list-style-type: none"> • Refill with salt. See the <i>Step-by-Step Installation Instructions</i>. Use the TOUCH OR HOLD button to start a regeneration. See the <i>About the water softener system</i> section.
	<p>Transformer unplugged at wall outlet or power cable to softener not connected. Fuse blown or circuit breaker popped on circuit to electrical outlet. Electrical outlet on a circuit that can continuously be switched off</p>	<ul style="list-style-type: none"> • Check for a loss of electrical power to the water softening system, due to any of these conditions and correct as needed. With the power supply restored, observe the faceplate time display and read <i>Programming the Control</i> section. <i>NOTE: The electrical outlet for the softener should be live so it cannot be accidentally switched off.</i>
	<p>Manual bypass valve in bypass position</p>	<ul style="list-style-type: none"> • Be sure the bypass valve stem is positioned properly, with the knob in the OUT position. Observe instructions on the decal at the end of the stem.
	<p>Valve drain hose pinched, plugged, elevated too high or otherwise restricted</p>	<ul style="list-style-type: none"> • Any restriction in this drain hose may prevent proper operation of the nozzle and venturi and reduce or prevent brine draw during recharge.
	<p>Nozzle and venturi dirty, incorrectly assembled or damaged</p>	<ul style="list-style-type: none"> • Refer to <i>Cleaning the Nozzle and Venturi Assembly</i> instructions. With water pressure to the water softening system off, take the nozzle assembly apart. Inspect, clean and replace as needed. Any foreign particle(s), scratches, nicks, etc., in the passages can prevent operation. Be sure holes in the gasket are centered over holes in the housing.

Problem	Possible Causes	What To Do
<i>Water hard sometimes</i>	Using hot water while the water softening system is regenerating	<ul style="list-style-type: none"> • Avoid using hot water during water softening system recharge because the water heater will refill with hard water. See <i>Automatic Hard Water Bypass During Recharge</i> section, page 13.
	Control HARDNESS number setting too low	<ul style="list-style-type: none"> • Press the MODE button until arrow points to HARDNESS. Be sure the number shown is the same as the actual grains per gallon hardness of your water supply. See the <i>Programming the Control</i> section if a change in the setting is needed.
	Grains of hardness in your water supply have increased	<ul style="list-style-type: none"> • Water hardness can change over time, especially in well water. To check, have the water tested by a water analysis laboratory or call your local water department. Adjust the HARDNESS number setting as needed.
<i>Water feels slippery after installation of water softening system</i>	Absence of hardness minerals	<ul style="list-style-type: none"> • This is normal. Hardness in water gives it the abrasive feel you may have been accustomed to. The slippery feel is the clean feel of soft water.
<i>Water softening system not using any salt</i>	Water softening system is a "demand" unit	<ul style="list-style-type: none"> • Does not use much salt to regenerate—very efficient.
	Possible salt bridge	<ul style="list-style-type: none"> • See the <i>About the Water Softener System</i> section, page 14.
	Possible plugged nozzle and venturi	<ul style="list-style-type: none"> • See the <i>About the Water Softener System</i> section, page 14.
<i>Water is blue color after water softening system was installed</i>	Acidic water in copper plumbing	<ul style="list-style-type: none"> • Have the water tested at once.
<i>Water softening system not regenerating</i>	Meter turbine stuck	<ul style="list-style-type: none"> • See the <i>Service: Manually Initiated Electronics Diagnostics</i> section for troubleshooting procedures, page 17. • Call for service.
	Sensor wire not plugged into the control	<ul style="list-style-type: none"> • See the <i>Service: Manually Initiated Electronics Diagnostics</i> section for troubleshooting procedures, page 17. • Call for service.
	No power to unit	<ul style="list-style-type: none"> • Check the circuit breaker or fuses.
	Mechanical defect	<ul style="list-style-type: none"> • Call for service.
<i>Cloudiness on glassware (automatic dishwashers)</i>	Combination of soft water and too much detergent	<ul style="list-style-type: none"> • This is called <i>etching</i> and is permanent. To prevent this from happening, use less detergent if you have soft water. Wash glassware in the shortest cycle that will get them clean.
<i>Excessive/high level of water in brine tank</i>	Valve drain hose pinched, plugged, elevated too high or otherwise restricted	<ul style="list-style-type: none"> • Any restriction in this drain hose may prevent proper operation of the nozzle and venturi and reduce or prevent brine draw during recharge.
	Nozzle and venturi dirty, incorrectly assembled or damaged	<ul style="list-style-type: none"> • See the <i>Cleaning the Nozzle and Venturi Assembly</i> section, page 14. With water pressure to the water softening system off, take the nozzle assembly apart. Inspect, clean and replace as needed. Any foreign particle(s), scratches, nicks, etc., in the passages can prevent operation. Be sure holes in the gasket are centered over holes in the housing.

Before you call for service...



Troubleshooting Tips

Problem	Possible Causes	What To Do
Salty tasting or brown/yellow colored water after installation	Unit not sanitized	<ul style="list-style-type: none"> • Complete the <i>Sanitization Procedures</i> on page 12. • At completion of recharge cycle (approx. 2 hrs), run water from faucets to purge the salty water.
	Low water pressure	Check pressure. <ul style="list-style-type: none"> • Drain height 8' or less, pressure should be minimum of 20 psi. • Drain height above 8', pressure should be minimum of 50 psi.
	Restricted drain hose	<ul style="list-style-type: none"> • Clean and reconnect hose. • Check for kinks in drain line.
Brown/yellow colored water	Unit was idle for a period of time	<ul style="list-style-type: none"> • Complete the <i>Sanitization Procedures</i> on page 12.
Resin beads showing up in drinking water and sink	Cracked distributor	<ul style="list-style-type: none"> • Call for service.
Sounds you might hear	Running water from the unit into a drain during recharge	<ul style="list-style-type: none"> • This is normal.
Water has air bubbles and is cloudy	Air in system after installation	<ul style="list-style-type: none"> • Will go away after it runs for a while.
Error Code on control	Wiring may have worked loose in the control	<ul style="list-style-type: none"> • See page 16 for details. • Unplug transformer. • Remove control cover, release clips on side. • Check for loose/incorrect wiring connections to electronic board or switch. Reconnect as required. • Reassemble control cover. • Plug in Transformer. • Wait six minutes for Error Code to reappear. • If Error Code reappears, call for service.

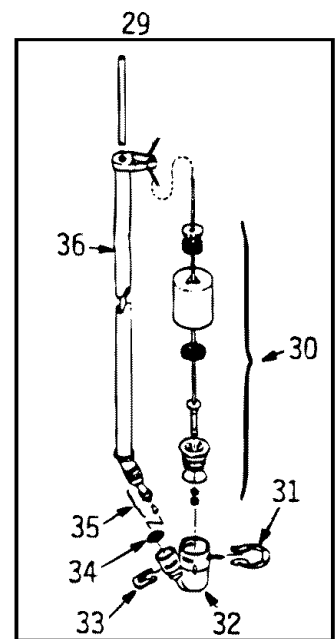
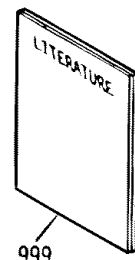
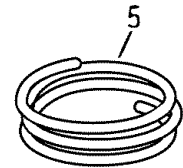
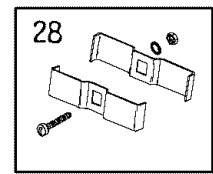
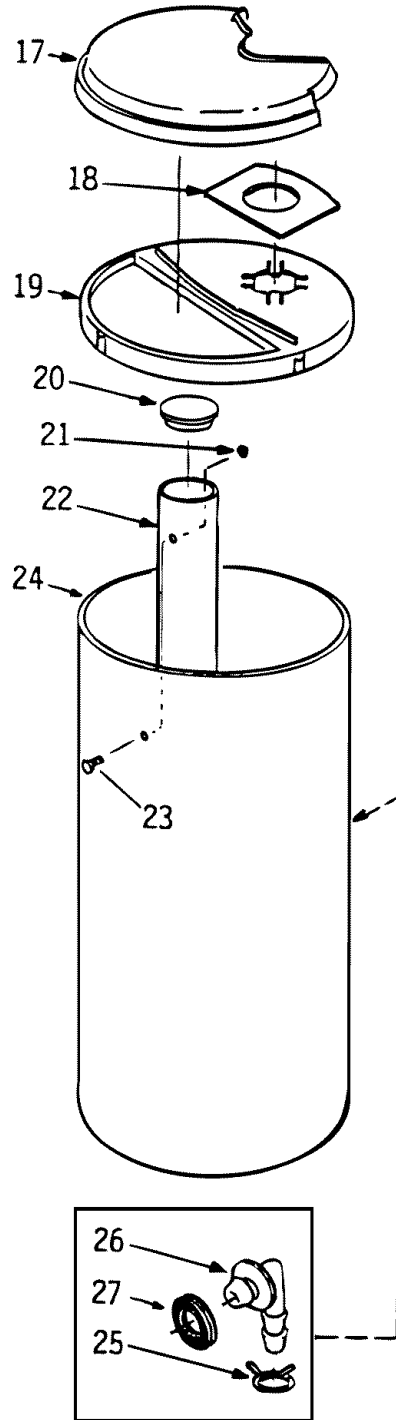
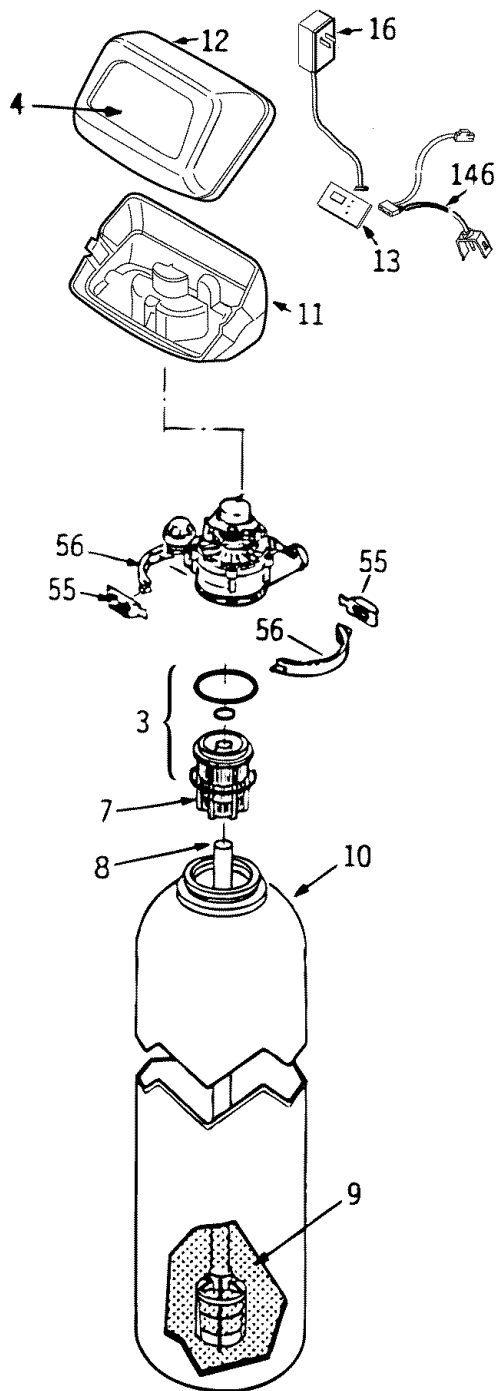

Parts list.

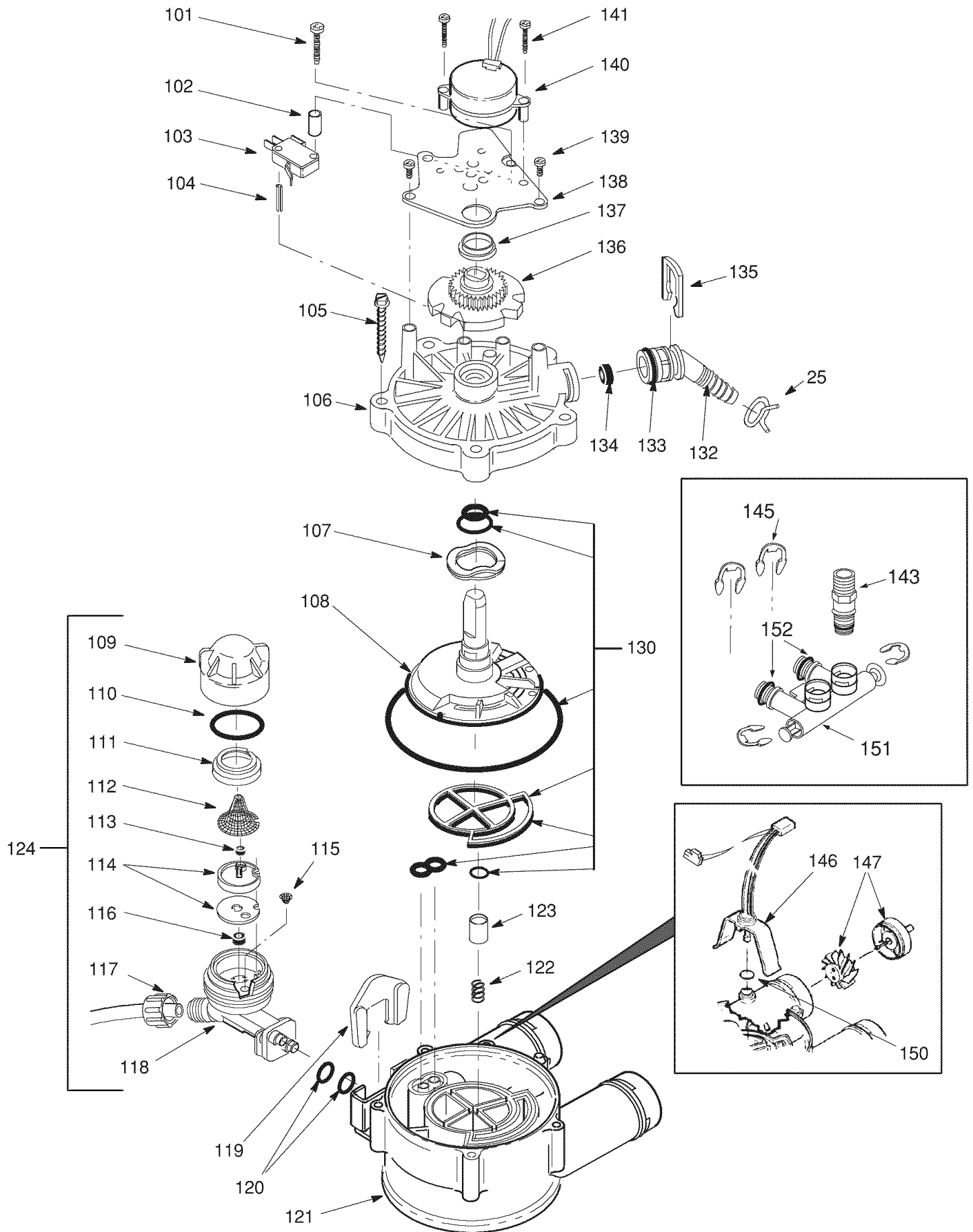

GENERAL ELECTRIC PARTS CATALOG

REF. NO.	PART NO.	PART DESCRIPTION	(04)
			G
			N
			S
			F
			3
			5
			Z
0003	WS35X10001	O-RING SEAL KIT	1
0004	WS34X10005	DECAL	1
0005	WS07X10004	HOSE DRAIN, 20 FT.	1
0007	WS14X10002	DISTRIBUTOR TOP	1
0008	WS14X10001	DISTRIBUTOR BOTTOM	1
0009	WS01X10002	RESIN - 1 CU. FT.	1
0010	WS32X10011	TANK RESIN	1
0011	WS31X10001	COVER BOTTOM	1
0012	WS31X10002	COVER CONTROL	1
0013	WS21X10012	CONTROL	1
0016	WS26X10013	TRANSFORMER WITH CORD	1
0017	WS31X10010	COVER SALT HOLE	1
0018	WS33X10001	SEAL VAPOR BARRIER	1
0019	WS33X10002	RIM	1
0020	WS31X10003	COVER BRINEWELL	1
0021	WS02X10009	WING NUT, 1/4" - 20	1
0022	WS32X10002	TANK BRINEWELL, ROUND	1
0023	WS02X10011	SCREW, 1/4" - 20 NYLON	1
0024	WS32X10003	TANK BRINE, ROUND	1
0025	WS18X10003	CLAMP HOSE	1
0026	WS22X10016	ADAPTER HOSE	1
0027	WS22X10017	GROMMET	1
0028	WS35X10035	GROUND CLAMP KIT	1
0029	WS15X10005	BRINE VALVE ASM.	1
0030	WS35X10003	FLOAT, STEM & GUIDE ASM.	1
0031	WS03X10006	CLIP	1
0032	WS15X10006	VALVE BODY, BRINE	1
0033	WS03X10007	CLIP	1
0034	WS03X10008	SCREEN	1
0035	WS07X10002	TUBING ASM.	1
0036	WS07X10003	TUBE BRINE	1
0055	WS28X10003	RETAINER CLAMP	2
0056	WS28X10004	CLAMP	2
0999	49-50181	PM MANUAL USE & CARE/ INSTALLATION	1
	WS35X10051	INSTALLATION KIT	

NOTE: Codes in the State of Massachusetts require installation by a licensed plumber and do not permit the use of the saddle valve. For installation, use plumbing code 248-CMR of the Commonwealth of Massachusetts.



GENERAL ELECTRIC PARTS CATALOG

REF. NO.	PART NO.	PART DESCRIPTION	(04)
0101	WS02X10012	SCREW, #4 - 24 X 1-1/8"	1
0102	WS02X10013	SPACER	1
0103	WS21X10003	SWITCH	1
0104	WS03X10009	PIN EXPANSION	1
0105	WS02X10014	SCREW, #10 - 14 X 2"	5
0106	WS31X10006	COVER VALVE	1
0107	WS03X10010	WASHER WAVE	1
0108	WS26X10002	ROTOR & DISC	1
0109	WS19X10004	CAP	1
0110	WS03X10011	SEAL O-RING 1.1" X 1.4"	1
0111	WS19X10005	SUPPORT SCREEN	1
0112	WS03X10013	SCREEN	1
0113	WS22X10020	FLOW PLUG, .1 GPM	1
0114	WS08X10005	GASKET, NOZZLE/VENT	1
0115	WS03X10015	CONE SCREEN	1
0116	WS22X10021	PLUG, FILL FLOW, .3 GPM	1
0117	WS03X10017	NUT FERRULE	1
0118	WS15X10009	NOZZLE/VENTURI ASM.	1
0119	WS03X10018	RETAINER	1
0120	WS03X10019	SEAL O-RING 1/4" X 3/8"	2
0121	WS15X10010	BODY VALVE	1
0122	WS03X10020	SPRING	1
0123	WS22X10022	PLUG, DRAIN SALT	1
0130	WS35X10005	SEAL KIT	1
0132	WS22X10023	ADAPTER DRAIN HOSE	1
0133	WS03X10021	O-RING 5/8" X 13/16"	1
0134	WS03X10022	PLUG FLOW, RINSE CONTROL	1
0135	WS03X10023	CLIP	1
0136	WS26X10003	CAM & GEAR	1
0137	WS26X10004	BEARING	1
0138	WS26X10005	PLATE MOTOR	1
0139	WS02X10015	SCREW, #6 - 20 X 3/8"	2
0140	WS26X10006	MOTOR ASM.	1
0141	WS02X10016	SCREW, #6 - 20 X 7/8"	2
0143	WS60X10013	ADAPTER—NPT THREADED—STD VALVE	2
0145	WS60X10004	CLIP	4
0146	WS28X10017	HARNES WITH SENSOR ASM.	1
0147	WS19X10006	TURBINE & SUPPORT ASM.	1
0150	WS03X10024	SEAL, O-RING	1
0151	WS15X10053	VALVE BYPASS ASM.	1
0152	WS03X10025	SEAL, O-RING	4

NOTE: Codes in the State of Massachusetts require installation by a licensed plumber and do not permit the use of the saddle valve. For installation, use plumbing code 248-CMR of the Commonwealth of Massachusetts.

GE Water Softening System Warranty.

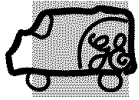

All warranty service provided by our SmartWater™ Authorized Servicer Network. To schedule service, call 800.952.5039 (U.S.) or 866.777.7627 (Canada). Please have serial number and model number available when calling for service.

Staple your receipt here.
Proof of the original purchase date is needed to obtain service under the warranty.

For The Period Of: We Will Replace:

One Year From the date of the original purchase	Any part of the Water Softening System which fails due to a defect in materials or workmanship. During this limited one-year warranty , GE will also provide, free of charge , all labor and related service to replace the defective part.
Three Years From the date of the original purchase	The electronic monitor , if it fails due to a defect in materials or workmanship. During this three-year limited warranty , you will be responsible for any labor or related service costs.
Ten Years From the date of the original purchase	A replacement brine tank or cabinet , if either fails due to a defect in materials or workmanship. During this ten-year limited warranty , you will be responsible for any labor or related service costs.

What Is Not Covered:

- Service trips to your home to teach you how to use the product.
- Improper installation, delivery or maintenance.
- Failure of the product if it is abused, misused, altered, used commercially or used for other than the intended purpose.
- Use of this product where water is microbiologically unsafe or of unknown quality, without adequate disinfection before or after the system. Systems certified for cyst reduction may be used on disinfected water that may contain filterable cysts.
- Replacement of house fuses or resetting of circuit breakers.
- Damage to the product caused by accident, fire, floods or acts of God.
- Incidental or consequential damage caused by possible defects with this appliance, its installation or repair.
- Product not accessible to provide required service.

EXCLUSION OF IMPLIED WARRANTIES—Your sole and exclusive remedy is product repair as provided in this Limited Warranty. Any implied warranties, including the implied warranties of merchantability or fitness for a particular purpose, are limited to one year or the shortest period allowed by law.

This warranty is extended to the original purchaser and any succeeding owner for products purchased for home use within the USA. If the product is located in an area where service by a GE Authorized Servicer is not available, you may be responsible for a trip charge or you may be required to bring the product to an Authorized GE Service location for service. In Alaska, the warranty excludes the cost of shipping or service calls to your home.

Some states do not allow the exclusion or limitation of incidental or consequential damages. This warranty gives you specific legal rights, and you may also have other rights which vary from state to state. To know what your legal rights are, consult your local or state consumer affairs office or your state's Attorney General.

Warrantor: General Electric Company, Louisville, KY 40225

Consumer Support.



GE Appliances Website

ge.com

Have a question or need assistance with your appliance? Try the GE Appliances Website 24 hours a day, any day of the year! For greater convenience and faster service, you can now download Owner's Manuals or order parts online.

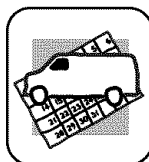

Schedule Service

ge.com

Expert GE repair service is only one step away from your door. Schedule your service at your convenience by calling 800.GE.CARES (800.432.2737) during normal business hours.

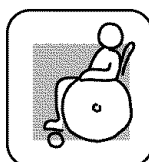

Real Life Design Studio

ge.com

GE supports the Universal Design concept—products, services and environments that can be used by people of all ages, sizes and capabilities. We recognize the need to design for a wide range of physical and mental abilities and impairments. For details of GE's Universal Design applications, including kitchen design ideas for people with disabilities, check out our Website today. For the hearing impaired, please call 800.TDD.GEAC (800.833.4322).



Extended Warranties

ge.com

Purchase a GE extended warranty and learn about special discounts that are available while your warranty is still in effect. You can purchase it on-line anytime, or call 800.626.2224 during normal business hours. GE Consumer Home Services will still be there after your warranty expires.

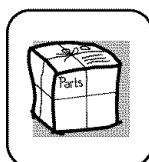

Parts and Accessories

ge.com

Individuals qualified to service their own appliances can have parts or accessories sent directly to their homes (VISA, MasterCard and Discover cards are accepted). Order on-line today, 24 hours every day or by phone at 800.626.2002 during normal business hours.

Instructions contained in this manual cover procedures to be performed by any user. Other servicing generally should be referred to qualified service personnel. Caution must be exercised, since improper servicing may cause unsafe operation.

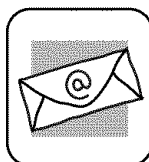

Contact Us

ge.com

If you are not satisfied with the service you receive from GE, contact us on our Website with all the details including your phone number, or write to:

General Manager, Customer Relations
GE Appliances, Appliance Park
Louisville, KY 40225



Register Your Appliance

ge.com

Register your new appliance on-line—at your convenience! Timely product registration will allow for enhanced communication and prompt service under the terms of your warranty, should the need arise. You may also mail in the pre-printed registration card included in the packing material, or detach and use the form in this Owner's Manual.