

# Kenmore Sewing Machine

## TABLE OF CONTENTS

### 1. KNOWING YOUR SEWING MACHINE

Machine identification .....	1 - 2
Setting your machine .....	3 - 4
Foot control, Light/power switch, Electronic needle control, Maximum speed control, Accessory box	
Parts list .....	5 - 6
Spool pins and caps .....	7
Converting to free-arm sewing .....	7
Winding the bobbin .....	8
Threading the bobbin case .....	9
Threading top thread .....	10
Picking up bobbin thread .....	11

### CONTROLS

Thread tension control .....	12
Stitch selector and indicator, Stitch width control .....	13
Stitch length control, Reverse stitch lever .....	14
Stitch modifier .....	14
Buttonhole control, Pressure regulator .....	15
Seam guides, Presser foot lever .....	15

### ACCESSORIES

Needles, Placement of needle .....	16
Needle, thread and fabric chart, Presser feet .....	17
Even feed foot, Adjustable holder .....	18
Edgestitcher, Quilting guide .....	19
Needle plates, Feed cover plate .....	20

### CARING FOR THE MACHINE

Cleaning feed dogs and shuttle .....	21
Oiling .....	22 - 23
Changing light bulb .....	23

### CHECKING PERFORMANCE PROBLEMS...24 - 25

### 2. STARTING TO SEW .....

Machine setting chart .....	27 - 28
Straight stitching .....	29 - 32
Fastening a seam, Turning asquare corner, Removing fabric, Darning, Temporary sewing by machine, Zipper application - cording, Narrow hemming, Quilting	
Zigzag stitching .....	33 - 35
Overcasting, Satin stitching, Bar tacking, Appliqueing, Embroidery, Monogramming, Button sewing	
Blind hemming .....	36
Stretch stitches .....	37 - 39
Recommendation, Adjusting stitch balance, Straight stretch stitch, Rick-rack stretch, Feather stretch, Smocking stretch, Elastic stretch, Overcast stretch, Paris point stretch	
Buttonhole making .....	40 - 46

**Model 17920  
17921  
17922**

**OWNER'S  
MANUAL**

# 1. KNOWING YOUR SEWING MACHINE

## IDENTIFICATION CHART

### FRONT VIEW

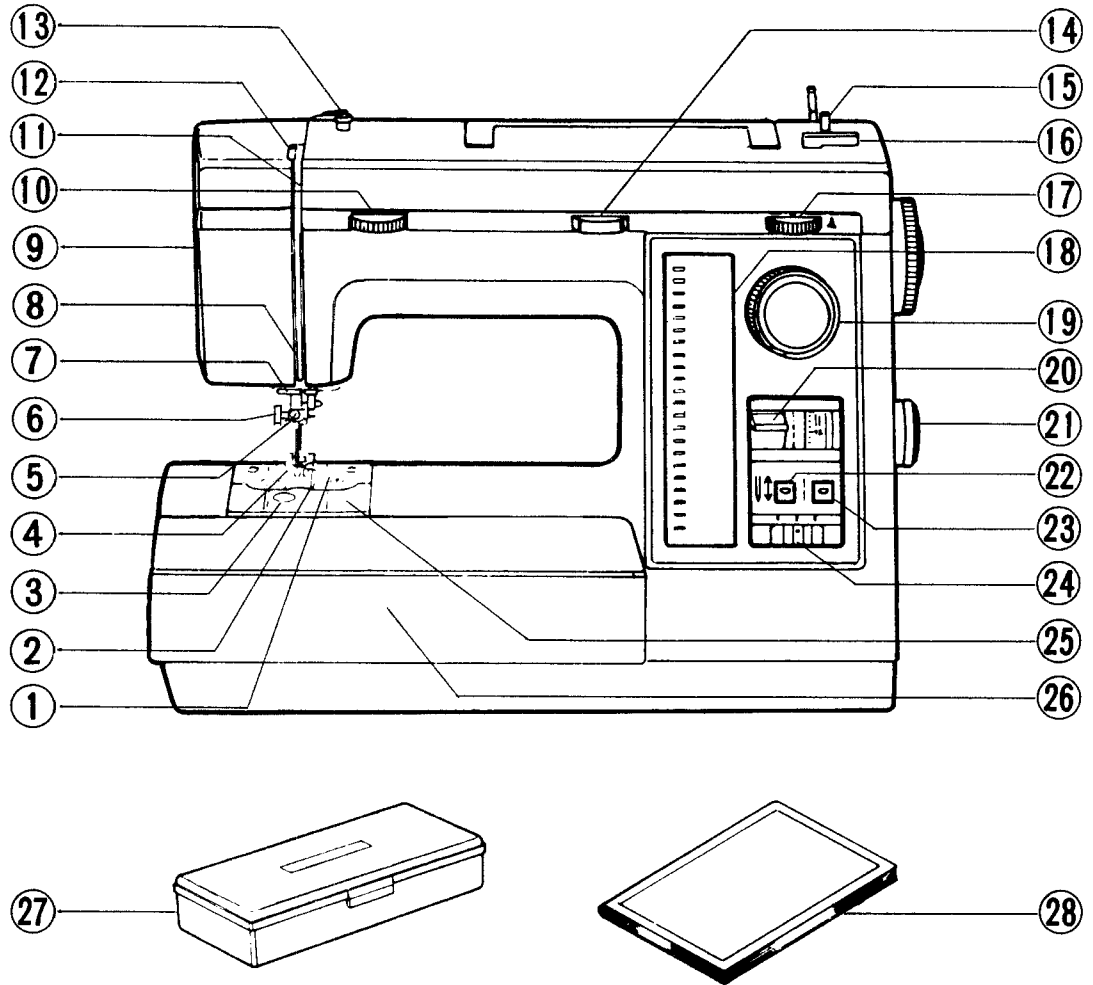

- |                                 |                               |
|---------------------------------|-------------------------------|
| 1. Needle plate                 | 15. Bobbin winder shaft       |
| 2. Feed dogs                    | 16. Bobbin winder latch       |
| 3. Bobbin window                | 17. Stitch width dial         |
| 4. Presser foot                 | 18. Stitch indicator          |
| 5. Needle clamp screw           | 19. Stitch selector           |
| 6. Presser foot thumb screw     | 20. Reverse stitch lever      |
| 7. Thread guide                 | 21. Stitch length dial        |
| 8. Check spring                 | 22. Needle up/down switch     |
| 9. Face cover                   | 23. Basting switch            |
| 10. Top thread tension control  | 24. Maximum speed control     |
| 11. Threading channel           | 25. Bobbin cover plate        |
| 12. Slotted take-up lever       | 26. Accessory box             |
| 13. Bobbin winder tension disc  | 27. Buttonholer/accessory box |
| 14. Built-in buttonhole control | 28. Owner's manual            |

## BACK VIEW

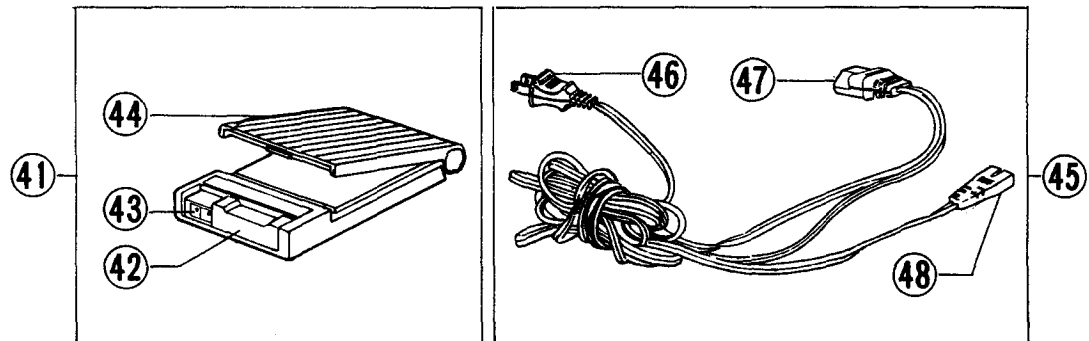
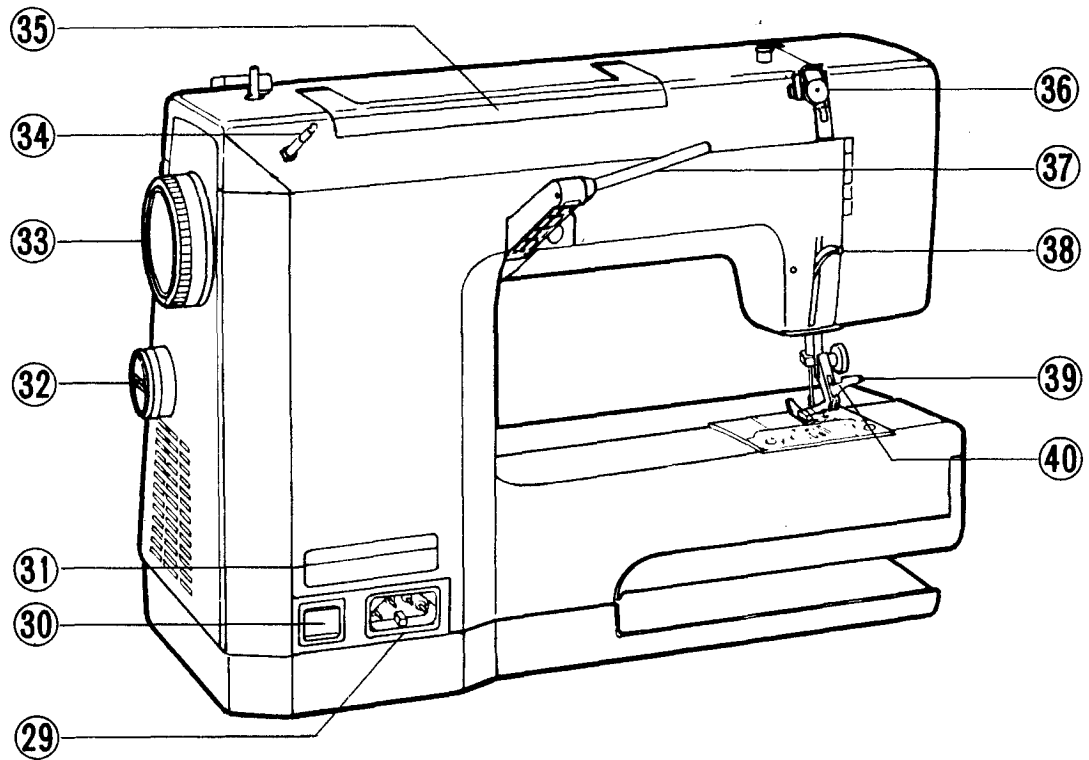

- |                                 |                                |
|---------------------------------|--------------------------------|
| 29. Electric cord receptacle    | 39. Presser foot release lever |
| 30. Light/power switch          | 40. Thread cutter              |
| 31. Nomenclature plate          | 41. Foot control               |
| 32. Stitch modifier             | 42. Pedal lock knob            |
| 33. Hand wheel/push-pull clutch | 43. Cord receptacle            |
| 34. Telescoping spool pin       | 44. Foot pedal                 |
| 35. Foldaway carrying handle    | 45. Foot control cord          |
| 36. Rear thread guide           | 46. Machine plug               |
| 37. Swing-away spool pin        | 47. Power-line plug            |
| 38. Presser foot lever          | 48. Foot control plug          |

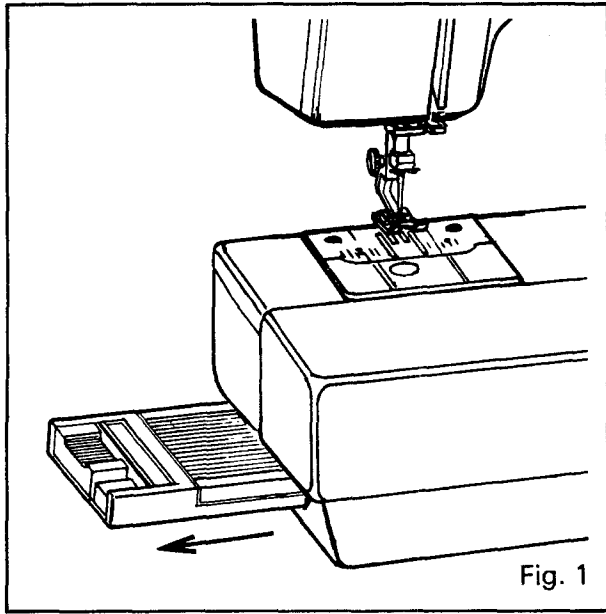

Fig. 1

## SETTING UP YOUR MACHINE

1. Install your Kenmore sewing machine in a Kenmore cabinet, case or set the machine on a sturdy flat surface.
2. Your Kenmore sewing machine has been thoroughly oiled at the factory. Be sure to wipe off the needle plate area and bed plate carefully before sewing a garment. It is wise to practice on a scrap of fabric so any surplus oil is absorbed.

### 3. FOOT CONTROL

Your machine is supplied with an electronic foot control which enables you to sew very slowly. Even at low speed you have extra power for the needle to penetrate through several thicknesses of fabric. Faster speeds are also easily controlled.

1. Pull out the foot control from its storage position under the free arm. (Fig. 1)

2. Slide pedal lock knob to the right and the foot pedal will **pop up** to its operating position. Push foot control plug into the cord receptacle on the foot control. (Fig. 2)

3. Push machine plug into the cord receptacle at the rear side of the machine. Then connect power-line plug into any 110-120 volt A.C. wall outlet. (Fig. 2)

### 4. LIGHT/POWER SWITCH

Your machine **will not operate** unless the light/power switch is turned on. This same switch controls the machine power, sewing light and indicator lights on the stitch indicator panel and electronic needle control. If you are interrupted or stop sewing, turn off the switch.

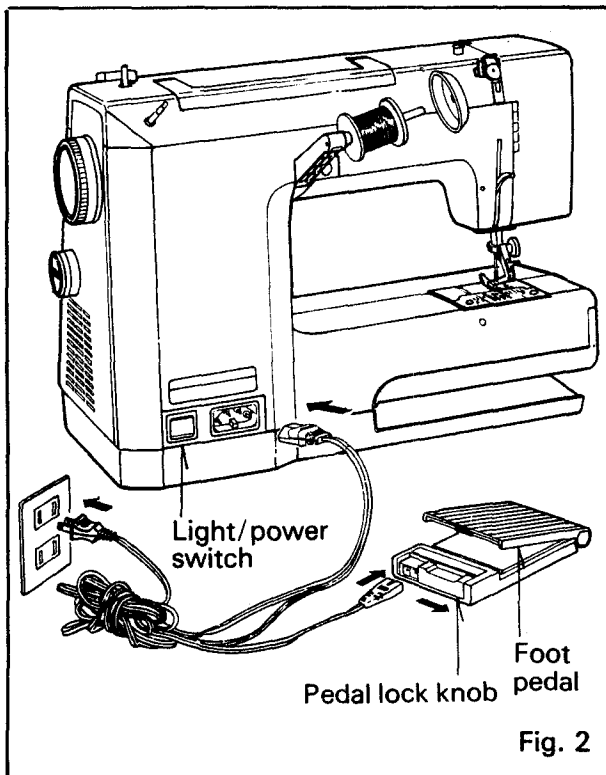

Fig. 2

## 5. ELECTRONIC NEEDLE CONTROL

Your machine is electronically controlled to stop with the needle in the up position every time you remove pressure from foot control.

### NEEDLE UP/DOWN SWITCH

When you want to lower the needle, push the **left switch** and the needle will move to the down position with red light turned on. Push it again or activate the foot control and the light will disappear to indicate the cancellation of needle down position and the needle will move back to the up position.

### BASTING SWITCH

Tap the foot control with the **right switch** pushed and lighted and the machine will take one stitch only and stop with needle in the up position. This feature provides an electronically controlled basting or tacking to take the chore out of hand basting.

## 6. MAXIMUM SPEED CONTROL

You may want to vary the speed of the machine, sewing slowly in special tight places or if you are a new seamstress. This control can be moved to the left to slow the sewing of the machine. To increase to the maximum speed, slide the control to the right.

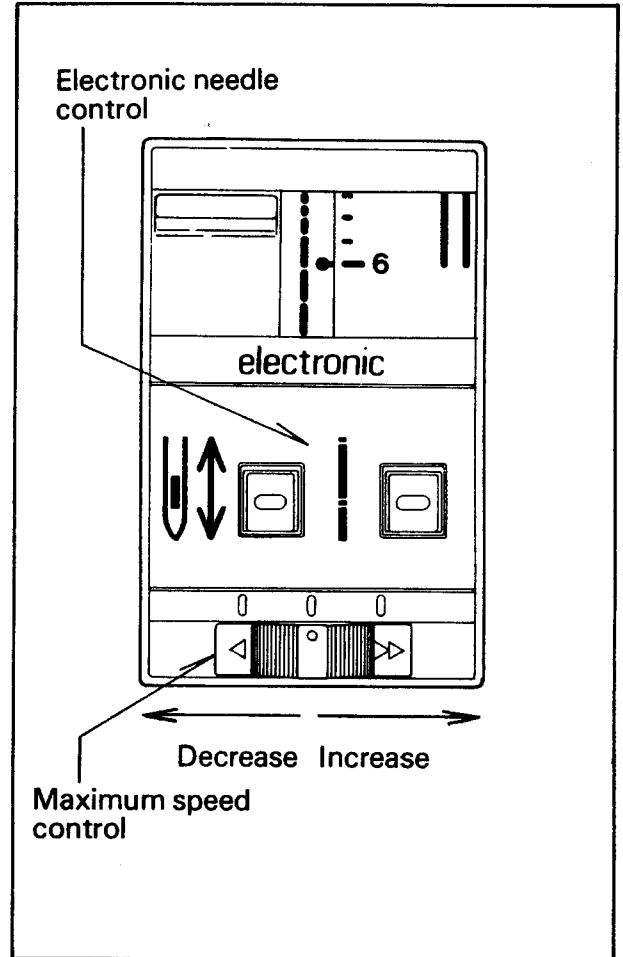

## 7. ACCESSORY BOX

Accessory box is opened by lifting the lid up and swinging it toward you as shown. Inside you will find many of the accessories that you use each time you sew.

The box may be fully removed from the machine to convert it for free arm stitching. See page 8.

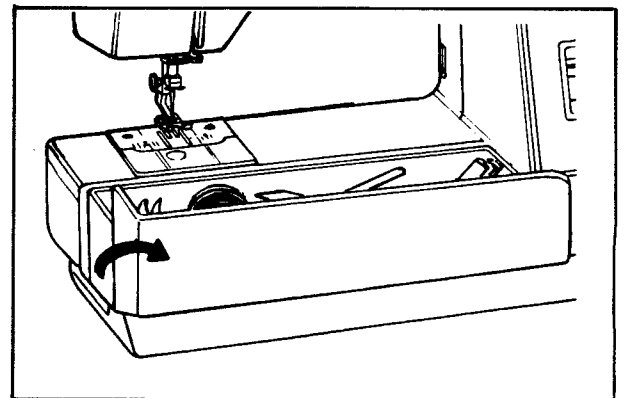

# PARTS LIST (Use only genuine Kenmore replacement parts and accessories.)

## PRESSER FEET

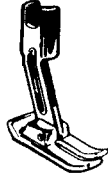

Straight Stitch  
(No. 45171)

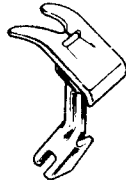

Standard Zigzag  
(No. 44985)



Satin Stitch  
(No. 44988)

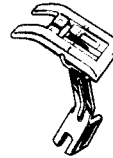

Plastic Satin  
Stitch (No. 43776)



"Q FOOT"  
(No. 6843)



"Q SET"  
(No. 6858)

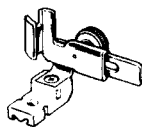

Zipper Foot  
(No. 6759)

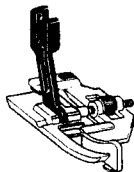

Blind Hem Foot  
(No. 6886)

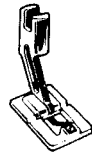

Overcasting  
(No. 35094)

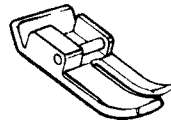

Straight Stitch  
(No. 57976)

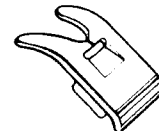

Standard Zigzag  
(No. 57975)

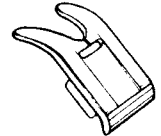

Satin Stitch  
(No. 57977)



Plastic Satin Stitch  
(No. 57978)

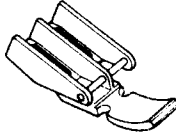

Zipper Foot  
(No. 59090)

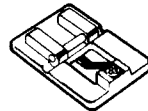

Overcasting  
(No. 57983)

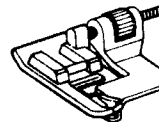

Blind Hem Foot  
(No. 57986)

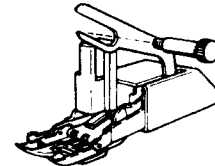

\* Even Feed Foot  
(No. 6888)

\* Included in the buttonholer box

## BUTTONHOLE ACCESSORIES

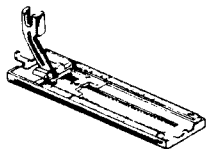

Built-in Buttonhole Guide  
Foot (No. 43840)

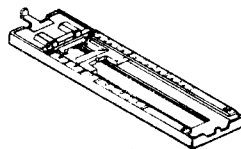

Built-in Buttonhole Guide  
Foot (No. 57984)

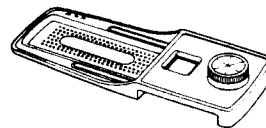

Buttonhole Guideplate  
(No. 58232)



Buttonhole Templates  
No. 1 Part 45195  
No. 2 Part 45196  
No. 3 Part 45197  
No. 4 Part 45198  
No. 5 Part 45199

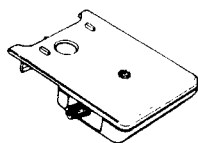

Buttonhole Cover  
Plate (No. 60753)

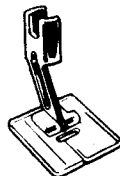

Buttonhole Foot  
(No. 41040)

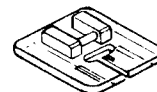

Buttonhole Foot  
(No. 57979)



Buttonhole Opener  
(No. 6830)

## OTHER VITAL ITEMS

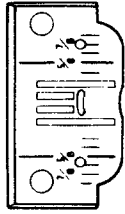

Zigzag  
Needleplate  
(No. 57860)

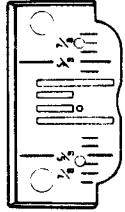

Straight Stitch  
Needleplate  
(No. 57861)

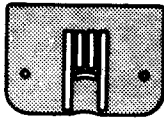

Feed Cover  
Plate  
(No. 43166)

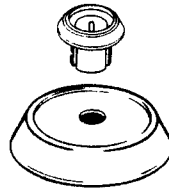

2 Spool Pin Caps  
Large — No. 55503  
Small — No. 53871



Nylon Disc  
(No. 2273)

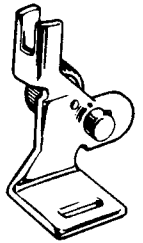

Adjustable  
Holder  
(No. 29308)

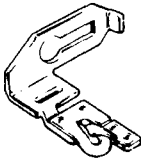

Narrow Hemmer  
(No. 29396)

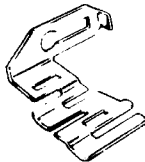

Edge Stitcher  
(No. 29306)



Quilting Guide  
(No. 28861)



Lint Brush  
(No. 35848)

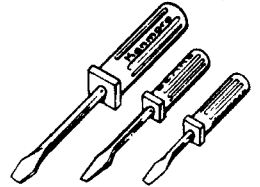

Large Screw Driver  
(No. 55501)  
Small Screw Driver  
(No. 55500)  
Magnetized  
Mini Screw Driver  
(No. 55499)



Bobbin Winder  
Rubber Ring  
(No. 1913)



Light Bulb  
(No. 6797)

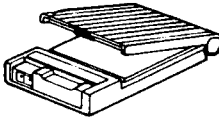

Foot Control  
(No. 57544)

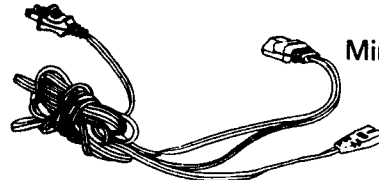

Foot Control Cord  
(No. 57543)



Bobbin Winder  
Tension Disc  
(No. 39619)

## OPTIONAL ACCESSORIES

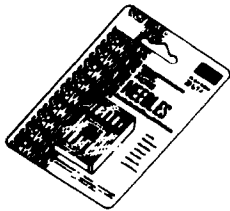

Packet of needles  
with your machine  
includes a variety of sizes.  
Replacement needles  
come in packages  
of one size only.

Needle Size	Part No.
No. 9	6550
No. 11	6551
No. 14	6552
No. 16	6553
No. 18	6554
"Q NEEDLE"	6746
Double Needle	6749

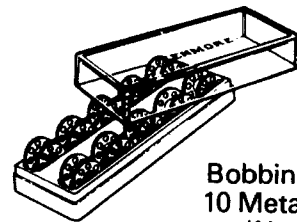

Bobbin Box with  
10 Metal Bobbins  
(No. 6862)  
Plastic Bobbins  
(No. 6868)

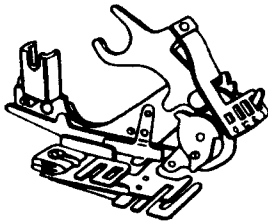

Ruffler/Pleater  
(No. 6895)



Needle Threader  
(No. 43780)

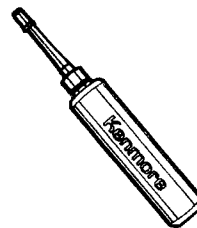

Oiler  
(No. 6890)

## SPOOL PINS AND CAPS

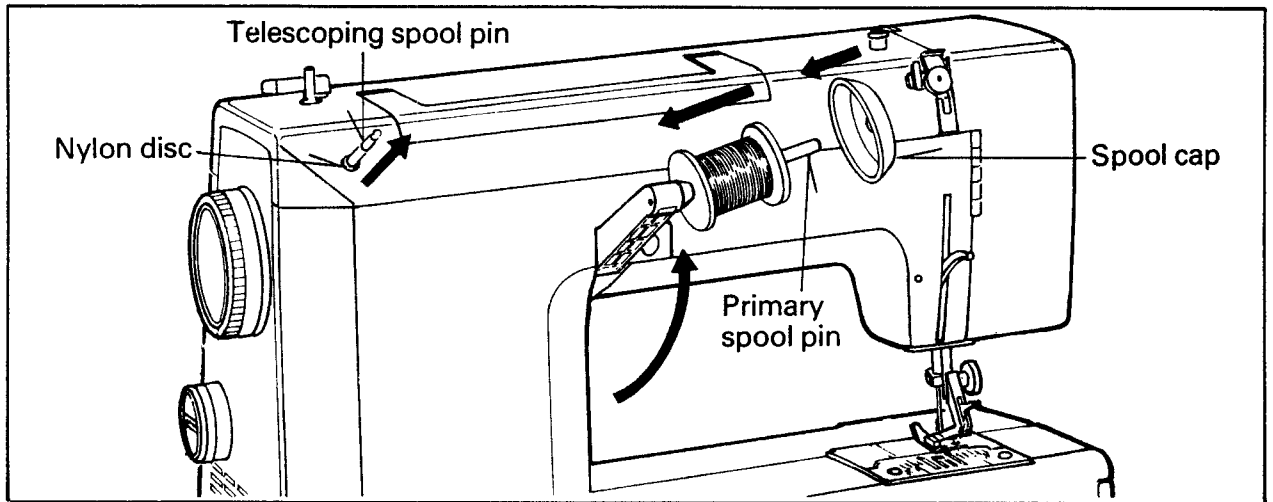

Swing the Primary Spool Pin into position at the back of the machine as shown above. Place a spool of thread on the pin and place the appropriate size spool cap over the thread.

A second telescoping spool pin is provided for bobbin winding and for a second thread when sewing with a double needle. Pull it out and place a nylon disc over it when using.

## CONVERTING TO FREE-ARM SEWING

This machine can be used either as a flatbed or as a freearm model. With the accessory box in place, the machine is a flatbed model with a large working surface, which slopes gently towards you to help the smooth flow of fabric.

By removing the accessory box, the machine converts into a slim freearm model for sewing children's clothes, cuffs, trouser legs, armholes and other awkward places.

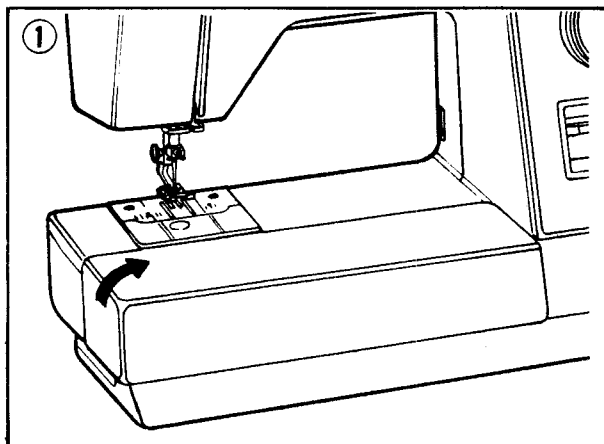

1. To remove the accessory box, take it firmly with your left hand and lift it up until it clicks. Your machine is then ready for free arm sewing.

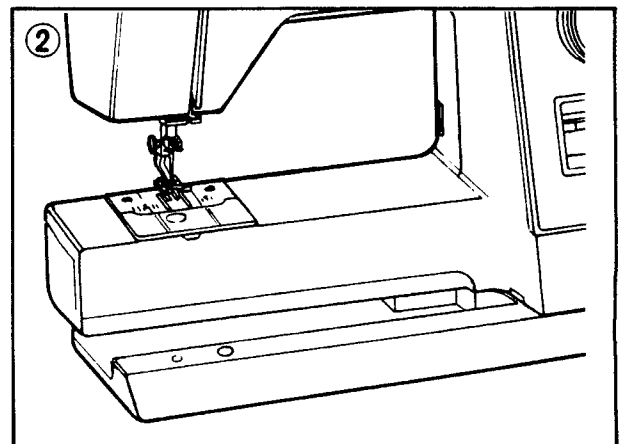

2. To replace, slide the accessory box back into place until it clicks.

## WINDING THE BOBBIN

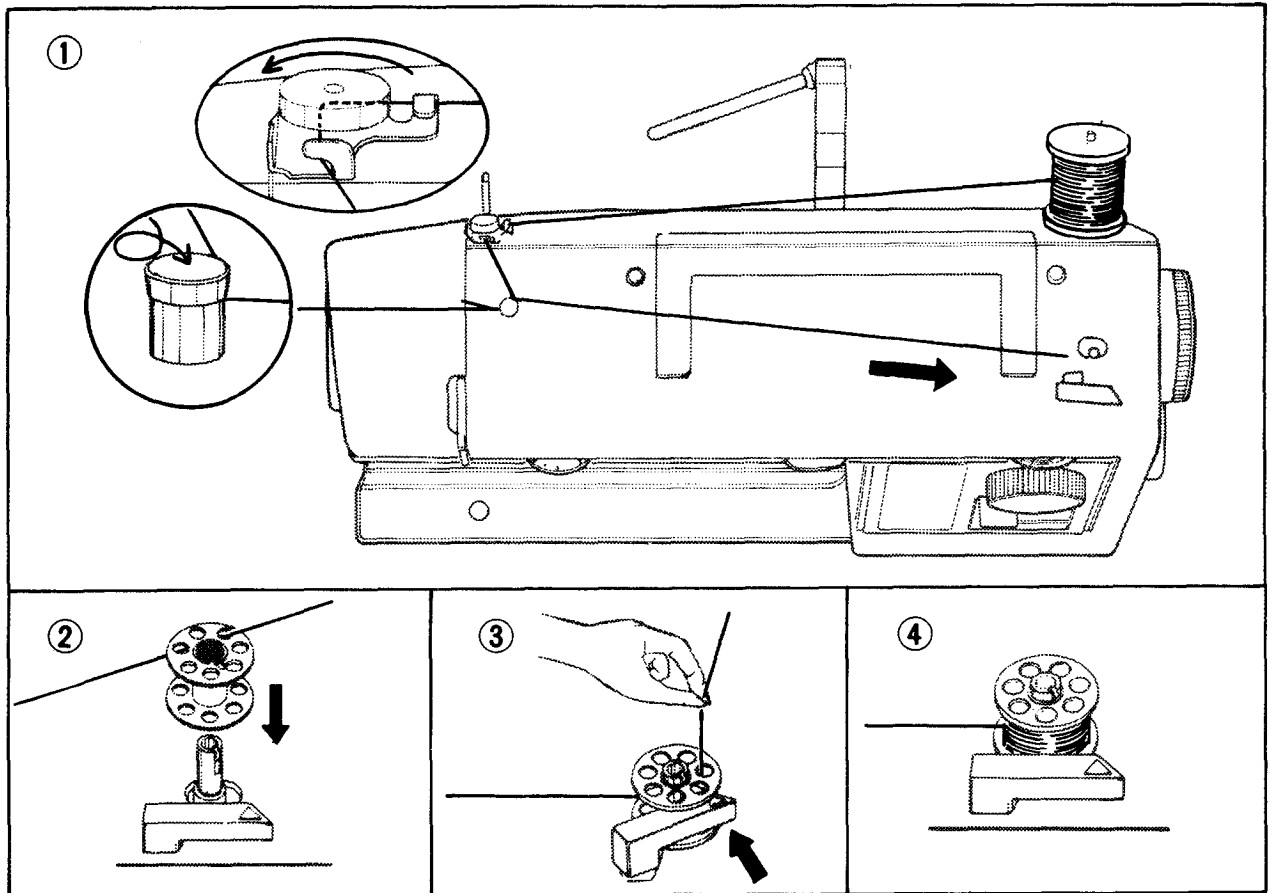

1. Place thread on Telescoping Spool Pin. Draw thread through Rear Thread Guide and Bobbin Winder Tension Disc as indicated.
2. Pull end of thread through any hole in bobbin; place bobbin on Bobbin Winder Shaft with end of thread coming from top of bobbin as shown above.
3. Push Bobbin Winder Latch against bobbin until it **clicks**. Then pull Hand Wheel **away** from machine to disengage clutch (see diagram below). Hold end of thread coming from bobbin (see above) and step on foot control. After several rotations of bobbin release thread.
4. **When bobbin is full, winding stops automatically.** Push in Hand Wheel. Remove bobbin from shaft and trim thread end.

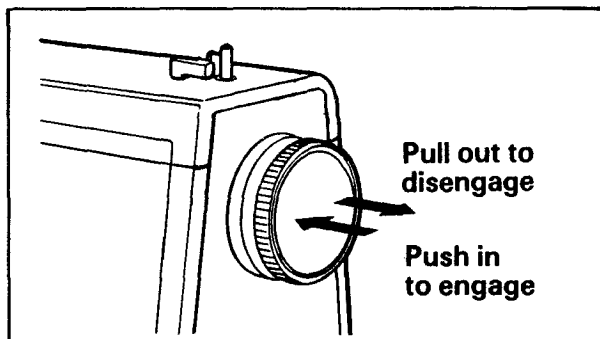

- \* **Treat Hand Wheel as a "clutch"**  
It controls the needle mechanism so that when pulled out (disengaged), the rest of the machine will not operate while the bobbin is being wound.

For best stitching results use clear plastic lightweight bobbins when stitching at high speed with widest and longest stitch setting.

## THREADING THE BOBBIN CASE

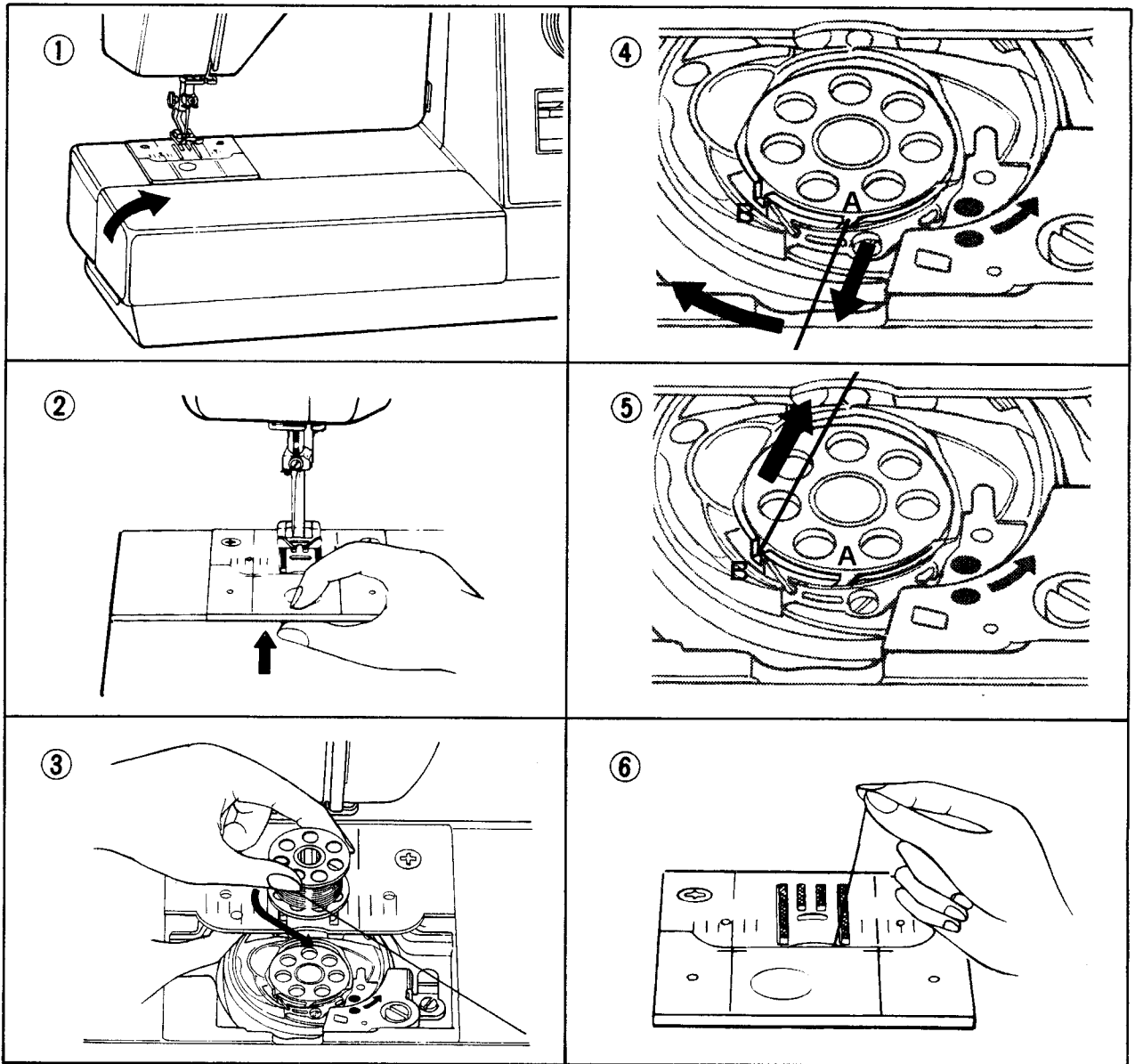

1. Remove accessory box.
2. Remove bobbin cover plate by lifting up the front.
3. Insert bobbin into bobbin case making sure bobbin rotates counter clockwise.
4. Pull thread through slot (A) and then to the left.
5. Pull thread through slot (B) and leave about 4 inches of thread.
6. Replace bobbin cover plate allowing thread to emerge through slot in needle plate.

## THREADING TOP THREAD

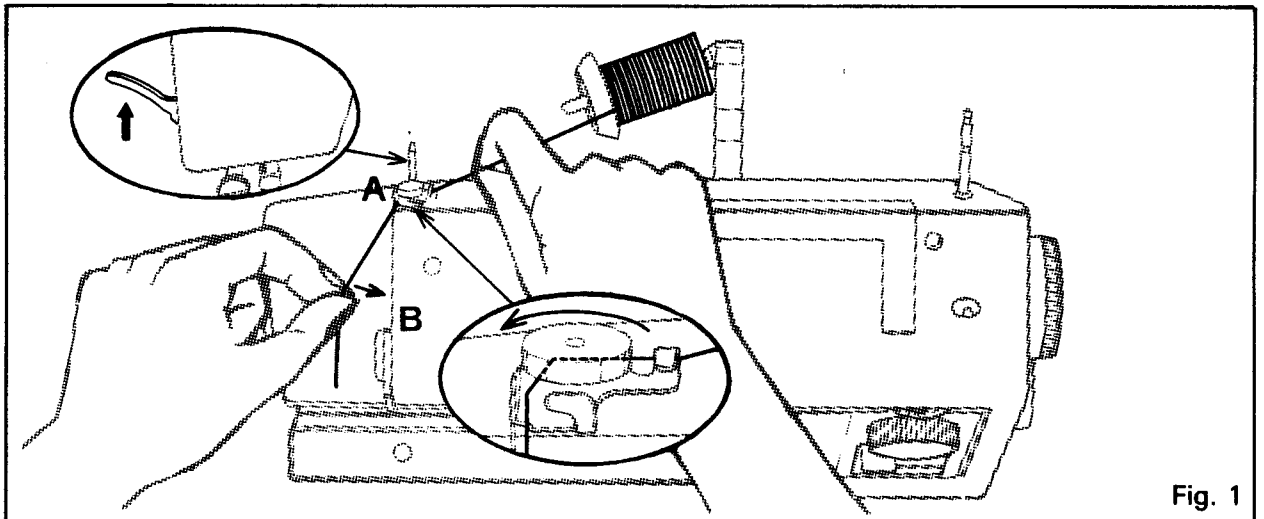

Fig. 1

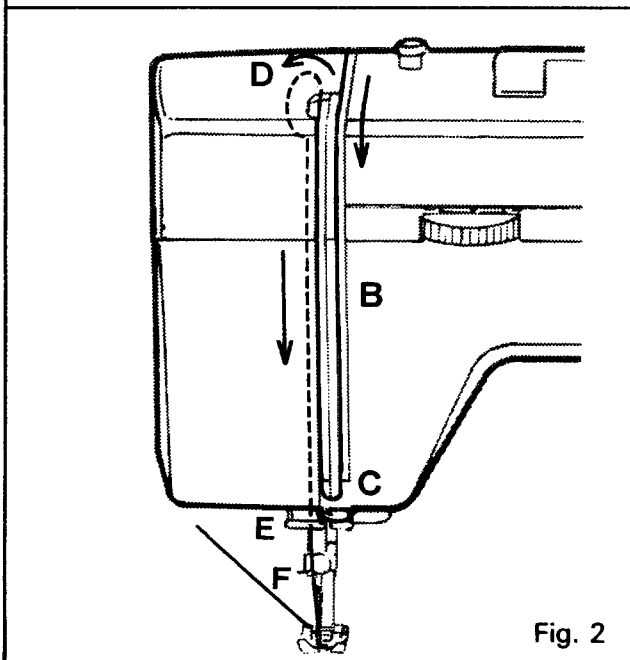

Fig. 2

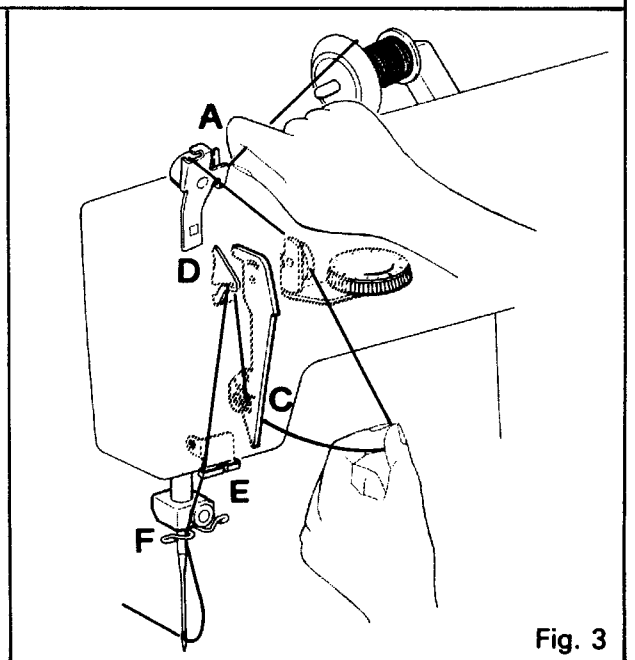
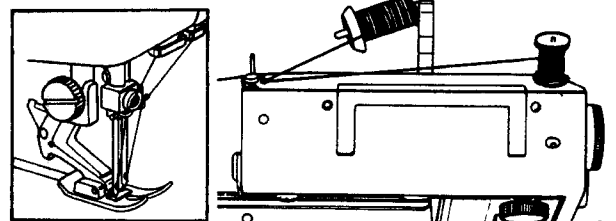

Fig. 3

1. Raise slotted take-up lever to its highest position.  
Place thread spool onto spool pin. Place appropriate spool cap over the spool of thread.  
Draw thread through rear thread guide (A) and into threading channel (B) toward you. (Fig. 1)
2. Draw thread down and around check spring (C) and up through slotted take-up lever (D). (Fig. 2)
3. Draw thread down into thread guides (E) and (F). Thread needle from front to back as shown in Fig. 3.

## THREADING DOUBLE NEEDLE

Place second spool of thread on second spool pin, and thread machine as you would for a single needle except double thread guides are provided. Draw one thread through each of these and through each side of needle from front to back.



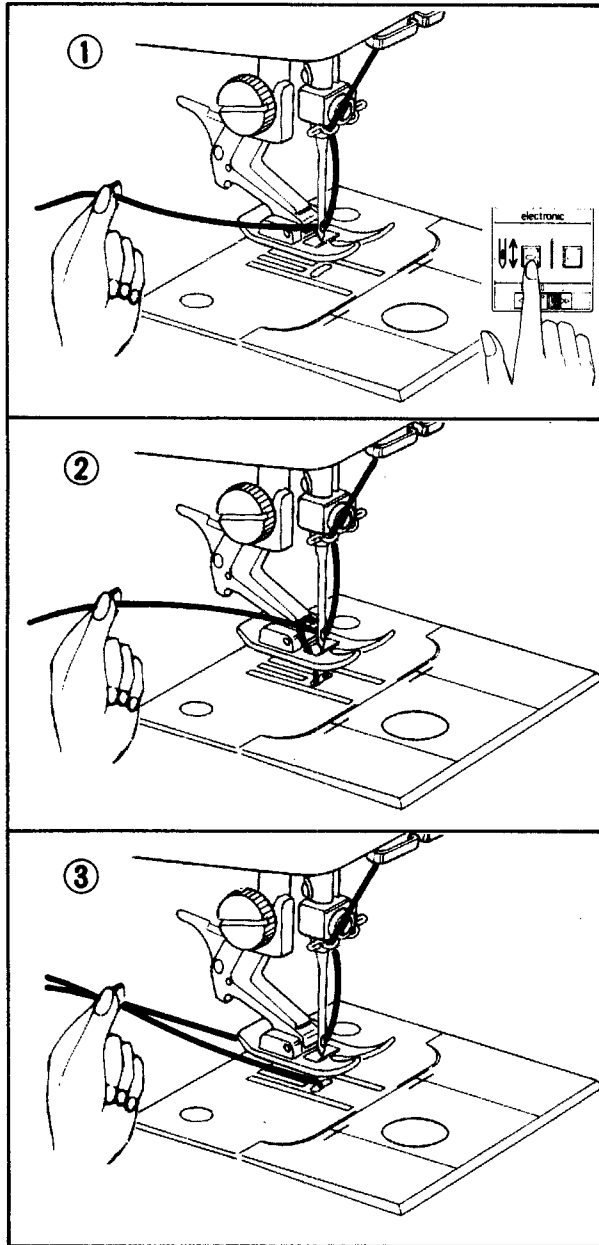

## PICKING UP BOBBIN THREAD

1. Raise presser foot lever.  
Hold needle thread loosely in left hand and push needle up/down switch **two times** or rotate hand wheel toward you one complete turn.
2. Bring bobbin thread up by pulling upper thread.
3. Pull both threads under and to the back of the presser foot, leaving 3 to 4 inches of thread clear.

If you can not pick up bottom thread by following above steps, then check:

1. Is needle threaded ?
2. Is thread tangled around needle ?
3. Is bobbin case threaded correctly with thread going through slots A and B as shown on page 9, Fig. 4 and 5 ?
4. Is there 4 inches of thread coming from bobbin case and through slot of needle plate as shown on page 9, Fig. 6 ?
5. Is thread from bobbin case tangled ?

## THREAD TENSION CONTROL

### STRAIGHT STITCHING

The good looking appearance of your stitching is largely determined by the balanced tension of both top and bobbin threads. The tension is well balanced when these two threads 'lock' in the middle of layers of fabric you are sewing.

For most fabrics the top thread tension control should be set in the white zone between 3 and 5.

If, when you start to sew, you find that the stitching is irregular, you will need to adjust the tension control.

Make any adjustments with presser foot 'down'.

1. If the threads are locking on the top surface with the top thread lying flat, the top stitch is too tight. Tension can be decreased by turning the tension control to the left (lower numbers).
2. If the reverse is happening with the threads on the underside of the fabric, the tension is too loose. This can be corrected by turning the tension control to the right (higher numbers).

### ZIGZAG STITCHING

The top thread may appear on the bottom depending on the thread, fabric, type of stitch and sewing speed, but the bobbin thread must never appear on the top of the fabric.

In the case of zigzag stitching, the wider the zigzag setting, the more chance there is of puckering. If this occurs decrease the top tension slightly and/or reduce the zigzag width.

### BOBBIN THREAD TENSION

The bobbin thread tension has been correctly set at the factory, so you do not need to adjust it.

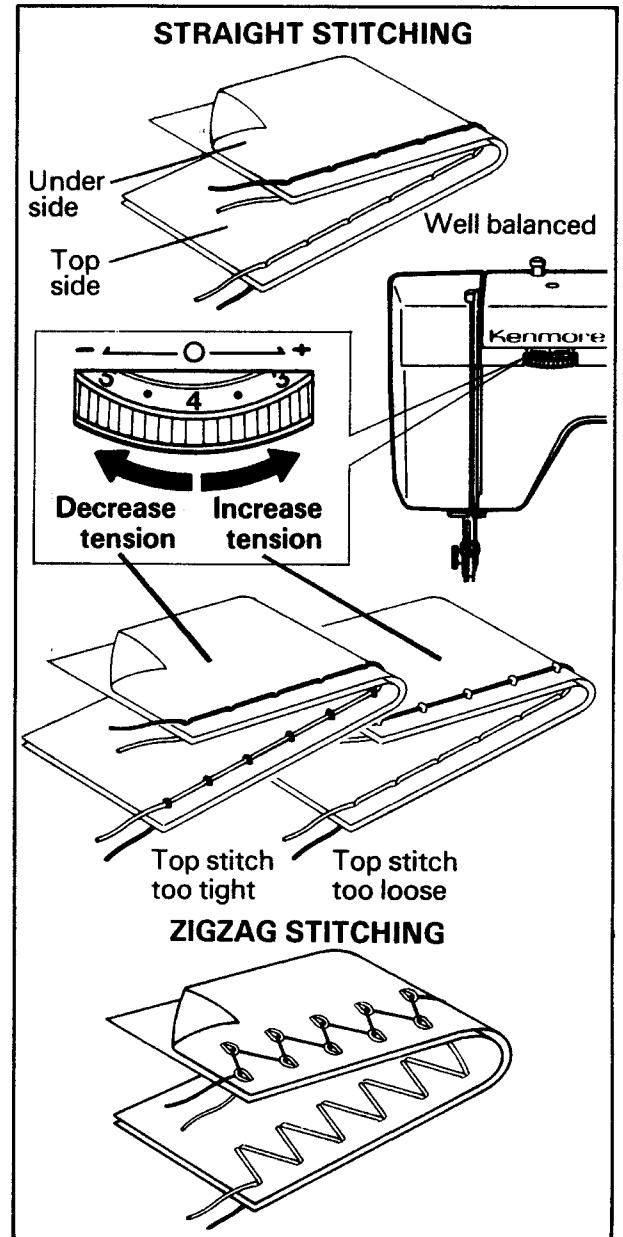

## MORE TIPS ON THREAD TENSION BALANCE

A perfect stitch is obtained when the tension is well balanced, but the tension balance may vary according to the type and size of needle, thread and fabric. The fabric determines size of thread and needle. The presser foot pressure and the thread tension control should also be adjusted properly.

### FABRICS:

Heavy fabrics, stiff - Increase top thread tension. Use larger size needle, heavier thread and longer stitch length.

Heavy fabrics, soft - Decrease top thread tension. Use longer stitch length.

Light, sheer fabrics - Decrease top thread tension and presser foot pressure. Use shorter stitch length. Sew slowly.

### THREADS:

Polyester and silk - Decrease top thread tension.  
Nylon - Increase top thread tension.

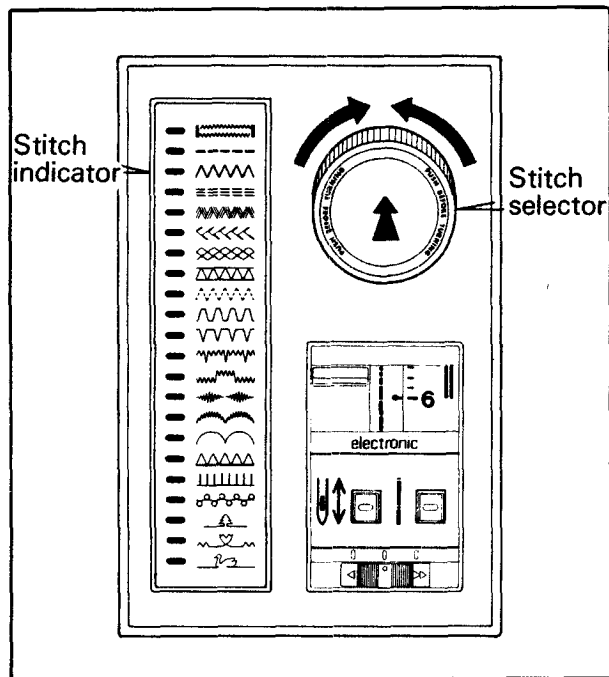

## STITCH SELECTOR AND INDICATOR

1. To select a stitch, be sure needle is out of fabric at its highest position. Push the stitch selector in and out to release the mechanism.
2. Then turn the selector to left or right until the required stitch is indicated by the red light on the indicator panel.

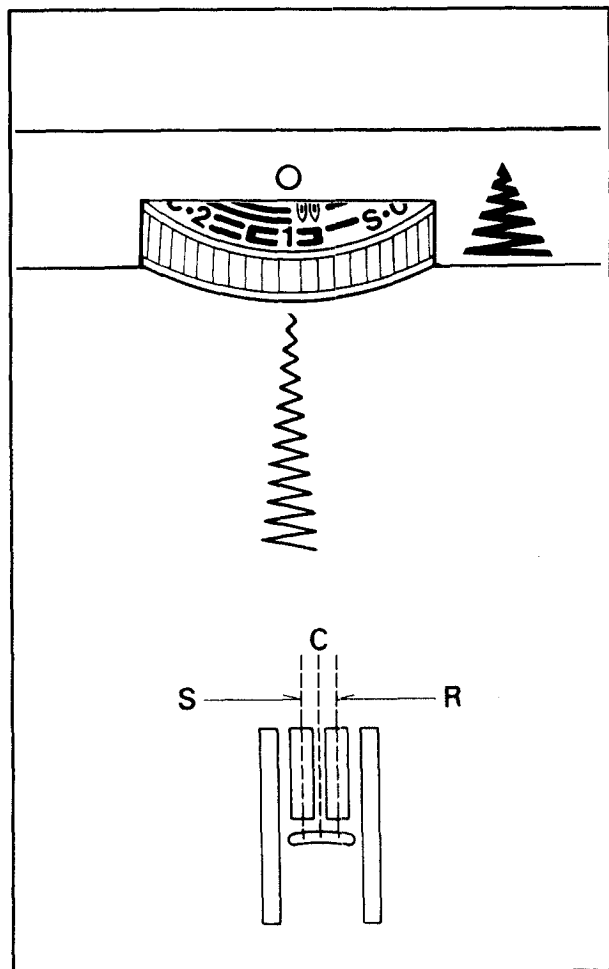

## STITCH WIDTH/NEEDLE POSITION CONTROL

### STITCH WIDTH CONTROL

The width of all the stitches produced on this machine, with the obvious exception of straight stitch, can be made narrower or wider by adjusting the stitch width control.

To decrease or increase the width of a stitch, turn the stitch width control dial from 0 - 4. The higher the number the wider the stitch.

Recommended setting ranges are indicated and color-coded with patterns on the stitch indicator panel.

When sewing with a double needle, do not use a setting above 2, as indicated on the dial.

### NEEDLE POSITION CONTROL

(Model 17922 only)

This dial is used to change needle position when straight stitching. Three different needle positions can be selected: S - standard position for general sewing, C - center and R - right.

## STITCH LENGTH CONTROL

The stitch length control regulates the length of the stitch you select. **THE HIGHER THE NUMBER-THE SHORTER THE STITCH.** Turn only the **outer rim** of this control to set the stitch length.

The number on stitch length control indicates the approximate number of stitches per inch. The stitch setting you use will be determined by the thickness of the fabric you are sewing.

A longer stitch setting should be used for thicker fabric or more layers of fabric. The middle range of the control is the 12 stitch per inch range which is the most commonly used.

Recommended stitch length settings are indicated in three colors. The colors are color-coded with the stitches on the indicator panel.

The red marking  between 0 and 24 is the setting used for the shortest stitches such as in satin stitching.

## REVERSE STITCH LEVER

It is best to begin and end seams with a few stitches taken in reverse. This is called back tacking. Back tacking fastens the ends of the seams firmly and prevents raveling.

When reverse stitching is needed, push down the lever and hold there during sewing. The fabric will immediately start feeding backwards and seam will be fastened.

## STITCH MODIFIER

When using stretch stitches and making buttonholes, you may need to make use of the stitch modifier. This regulates the movement of the fabric backwards and forwards to produce perfect stitches on fine or thick fabrics.

The stitch modifier should be in neutral notched position for most materials.

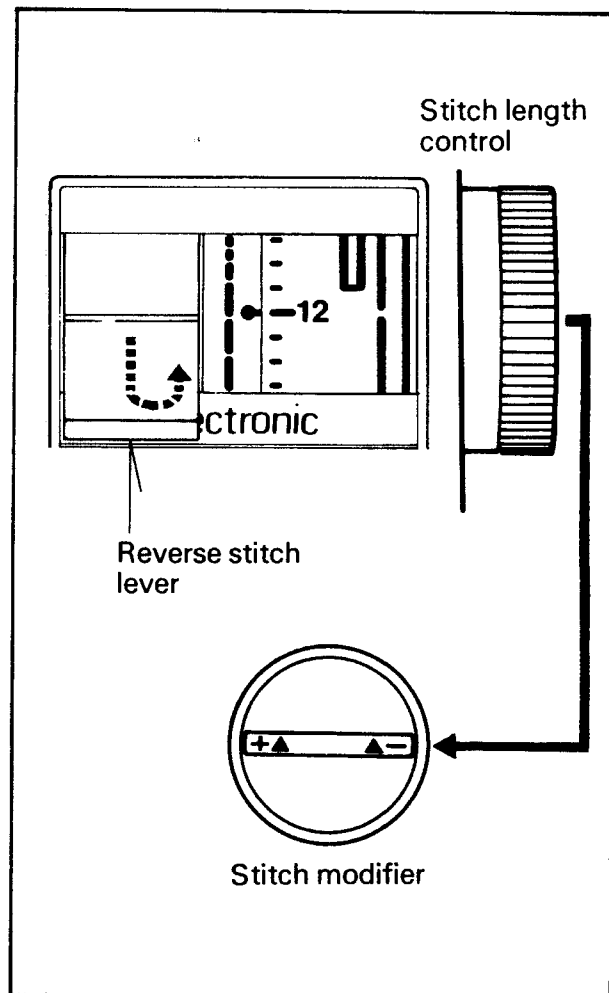

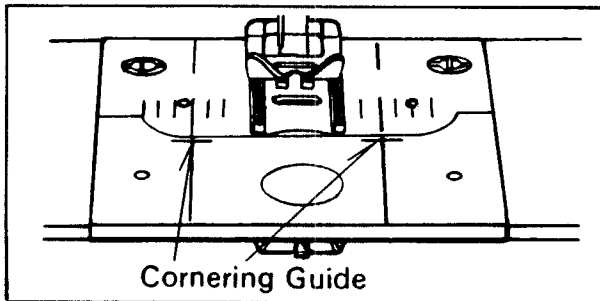

## SEAM GUIDES

Seam guides are printed on needle plate, at both sides of needle, to help you line up the fabric and keep it straight. The standard seam width is 5/8". So these lines are emphasized, easy to follow.

Also the cross lines are "cornering guides" to help when turning a square corner 5/8" from the fabric edge. (For details on cornering, see page 29.)

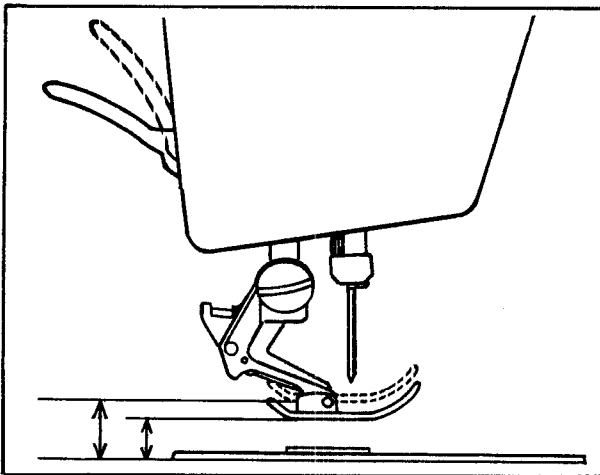

## PRESSER FOOT LEVER

Presser foot lever has a two position lift. In order to place heavy fabric under the presser foot or to change the presser foot raise the presser foot lever to its maximum upward position as shown.

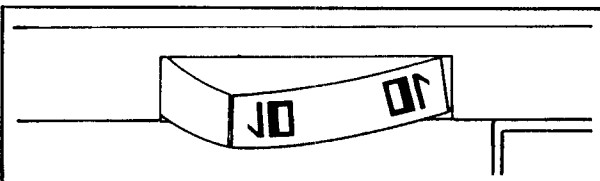

## BUTTONHOLE CONTROL

This control is used in making bar tacked buttonholes with two control settings. Detailed instructions are given on page 51.

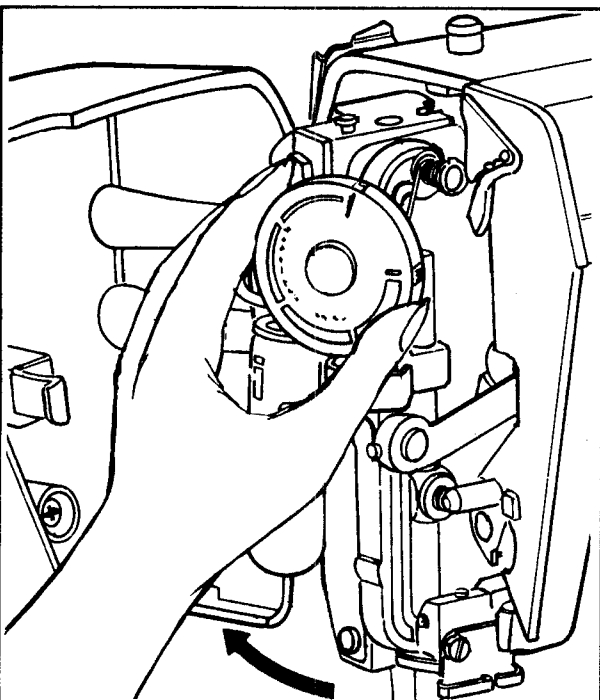

## PRESSURE REGULATOR

Presser foot pressure is vital for straight seams, uniform stitch length, even handling of both layers of fabric. To adjust pressure; use Pressure Regulator which is situated inside the face cover. Then to increase pressure, turn the dial clockwise (or vice versa). Just remember... for **lightweight** fabric, more pressure; for **heavy** fabric, less pressure.

# ACCESSORIES

## NEEDLES

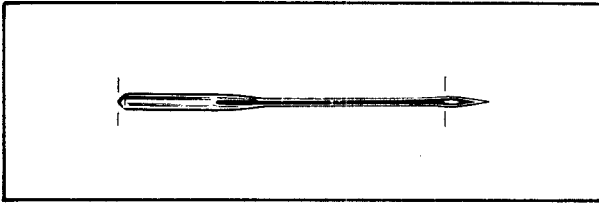

Use KENMORE needles. The size of the needle should conform with the size of the thread and both should be suitable to the fabric. Kenmore needles are color-coded by size for your convenience (See chart on facing page).

Never use a bent needle or one with a dull point.

If you do not have a Kenmore needle, please use this illustration to be sure your needle is the right size. Distance from top of needle to needlehole should be this exact length.

You will find among your accessories a "Q NEEDLE"™ with blue shank. This special needle is to be used when sewing knits and certain difficult synthetic fabrics. If you experience **skipped stitches** in any of your sewing, use "Q NEEDLE"™ and "Q FOOT"™.

## NEEDLE, THREAD AND FABRIC CHART

FABRIC	NEEDLE SIZE AND COLOR	THREAD SIZE	RECOMMENDED STITCH LENGTH SETTING
<b>LIGHTWEIGHT:</b> Batiste, Dimity, Chiffon, Silks, Synthetic Jerseys, Fine Lace, Organza, Crepe, Taffeta, Voile, Organdy	9-BROWN or 11-ORANGE	Polyester Core/Cotton Wrap Fine Mercerized Cotton Silk A	12 stitches per inch
<b>MEDIUMWEIGHT:</b> Cotton, Cotton Blends, Percalé, Gingham, Shantung, Pique, Seersucker, Satin, Knits, Vinyl, Suitings, Linen, Wool Crepe, Leather	14-RED	Polyester Core/Cotton Wrap 50 Mercerized Cotton Silk A	10 to 12 stitches per inch
<b>MEDIUM HEAVYWEIGHT:</b> Corduroy, Denim, Wool, Sailcloth, Wool Flannel, Gabardine, Velvets, Leather	14-RED or 16-PURPLE	Polyester Core/Cotton Wrap 50 Mercerized Cotton Mercerized Heavy-Duty Silk A	8 to 10 stitches per inch
<b>HEAVYWEIGHT:</b> Coatings, Upholstery, Cotton Duck, Heavy Twills, Canvas	18-GREEN	Polyester Core/Cotton Wrap Heavy-Duty Mercerized Cotton Polyester Synthetic Silk A	8 stitches per inch
Decorative top-stitching on all types of fabric	16-PURPLE 18-GREEN or Q-BLUE	Buttonhole Twist	6 stitches per inch
<b>Synthetic Knits and Stretch:</b> Polyester Double Knits, Nylon Tricot, Jersey, Stretch Terry, Spandex, Cire Tricot	Q-BLUE with "Q FOOT"™	Polyester Core/Cotton Wrap 50 Mercerized Cotton	10 for Regular or 6 for Stretch Stitches

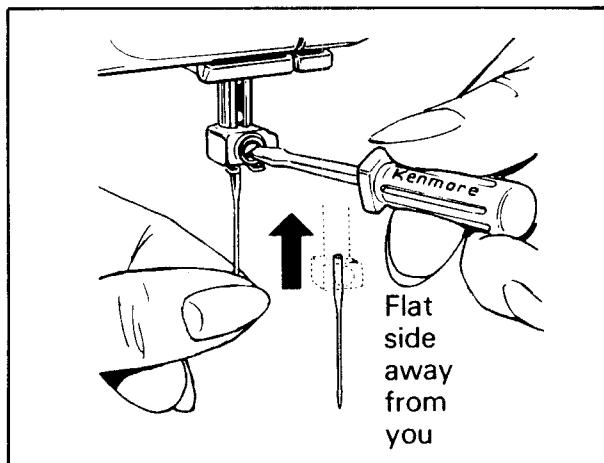

## CHANGING NEEDLE

Raise needle bar to its highest position by turning the hand wheel toward you. Loosen the needle clamp screw. Holding the needle with the **flat side away from you**, slip the needle into the needle bar. When it is in as far as it will go, tighten the needle clamp screw with small screwdriver provided in the accessory box.

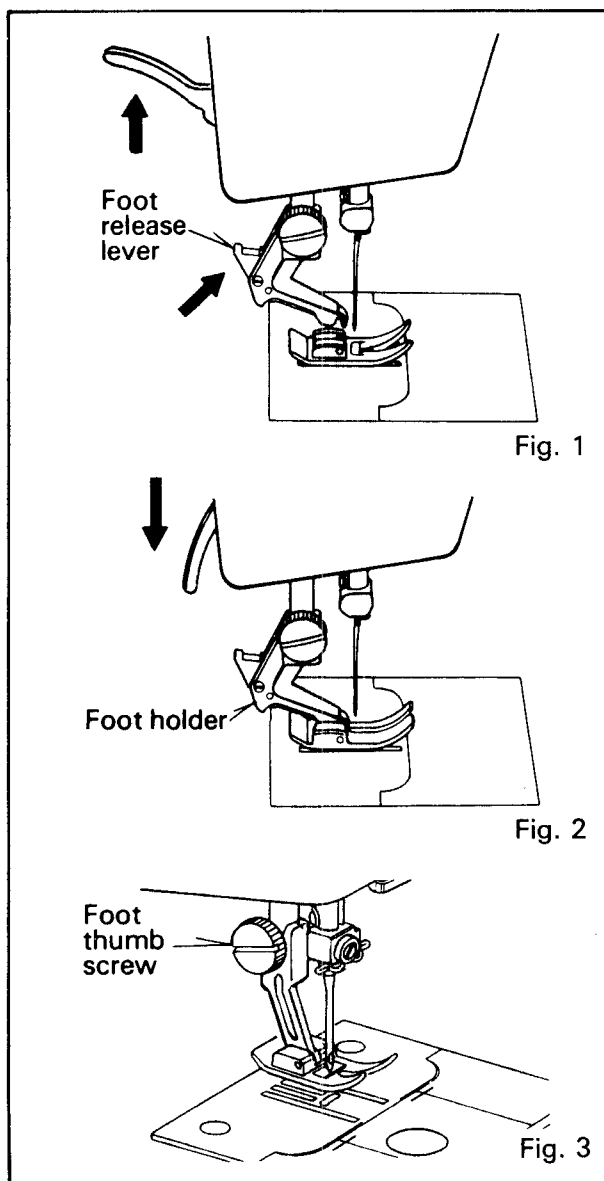

## PRESSER FEET

This machine is supplied fitted with a zigzag presser foot for general sewing purposes. In the accessory box are the following additional presser feet:

1. Straight stitch foot
2. Metal and plastic satin stitch feet
3. Buttonhole foot
4. Built-in buttonhole guide foot
5. Zipper foot
6. Blind hem foot
7. Overcasting foot
8. "Q FOOT"™
9. Even feed foot
10. Narrow hemmer
11. Edge stitcher

## CHANGING PRESSER FEET

Be sure needle is in the up position. Raise presser foot lever.

### Snap-on presser feet

1. Raise foot release lever to remove the foot. (Fig. 1)
2. Place the desired foot on the needle plate aligning needle holes. (Fig. 1)
3. Lower the presser foot lever so that the foot holder snaps on the foot. (Fig. 2)

### One-piece presser feet

1. Loosen **presser foot thumb screw** and remove the foot holder.
2. Insert desired foot from the front. Lower the presser foot lever and tighten the screw using the large screw driver to make certain the foot is secure.

## EVEN FEED FOOT

The even feed foot moves top and bottom material together evenly and enables you to sew hard-to-sew fabrics without sliding nor slipping and with perfect matching. Use it for sewing leather, ultra suede™, shiny fabrics (vinyls, patents and satins), bonded fabrics, pile fabrics and matching stripes, plaids and patterns. It is not recommended for use when stretch stitching.

### To attach the even feed foot;

1. Raise needle to its highest position.
2. Raise presser bar to its highest position and guide the even feed foot into position from rear of machine.
3. Attach presser bar clamp to presser bar and tighten presser foot thumb screw.
4. Attach screw (A) provided with the foot to needle clamp through fork arm and tighten it.

Note: Attach the foot in exact order of steps as written.

### IMPORTANT:

To prevent friction and wear, put a drop of oil at each point indicated by arrows in Fig. 2 and set pressure regulator at 2 or 3 before using this foot.

Oil after 4 or 5 times usage. Be sure to remove excess oil by wiping foot thoroughly and sewing on a scrap of fabric.

## ADJUSTABLE HOLDER

Replace the regular presser foot holder with the adjustable holder when using narrow hemmer and edge stitcher attachment.

Loosen thumb screw and press it forward. Insert the opposite end into the large hole of the attachment. Slide the attachment to the left as far as possible. Adjust as necessary to the correct position for stitching. Tighten the thumb screw securely.

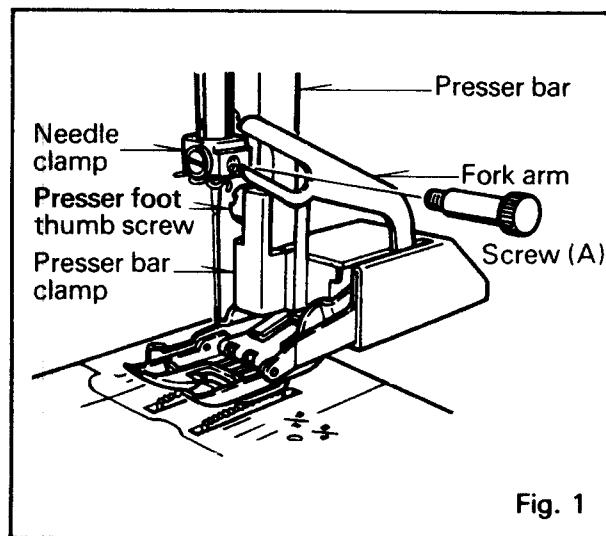

Fig. 1

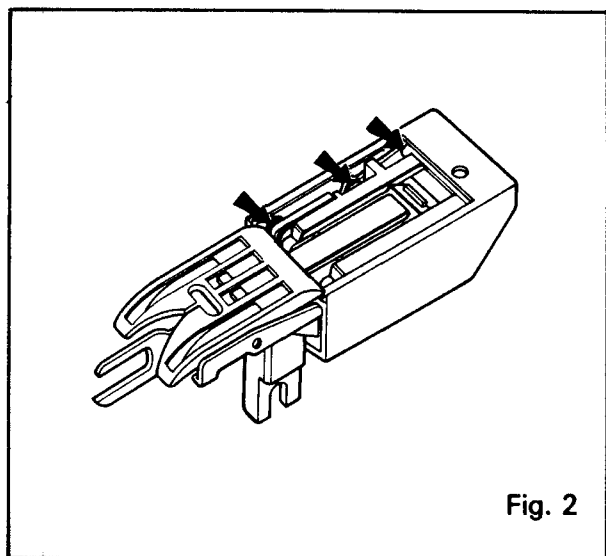
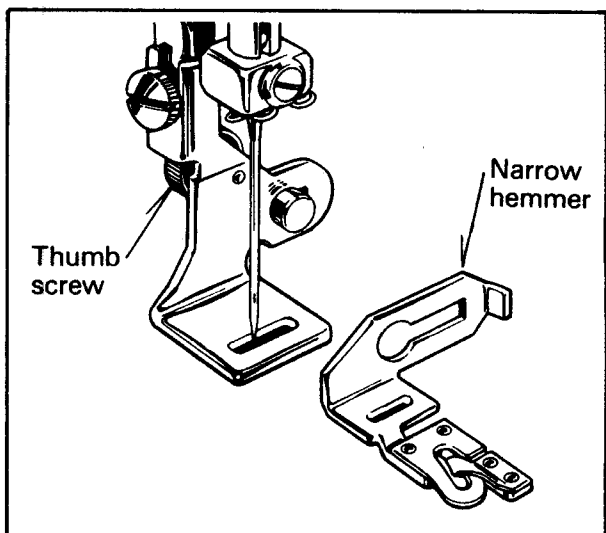
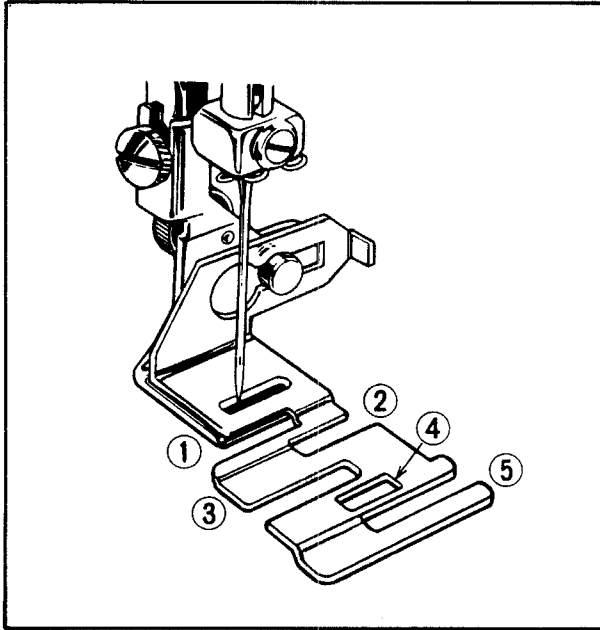

Fig. 2





## EDGESTITCHER

This one attachment helps you join fabric edges ...insert lace ...do seam piping ...simplifies blind hemming as well as "French" seams. Slots numbered 1 to 5 serve as sewing guides:

**Slot 1** will guide fabric to be joined to lace. All you have to do is place the lace in slot 2. (A)

**Slot 4** will guide piping being joined to fabric edges. Place the fabric in slots 2 or 3. (B)

**Slot 5** may be used as a guide when sewing French seams which are stitched twice, once on **right** side and once on **other** side. This is the classic seam for sheers. (C)

**Use slots 1 and 3** to guide fabric with ease during blind hemming. (D)

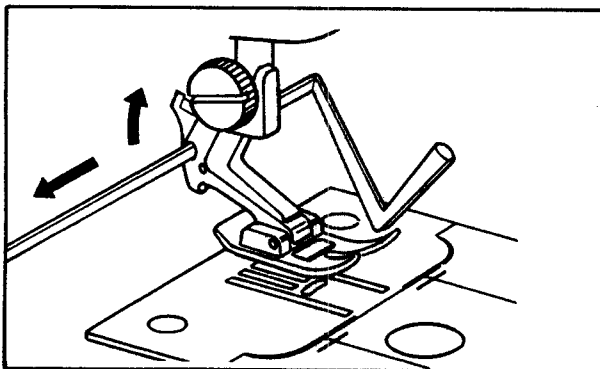
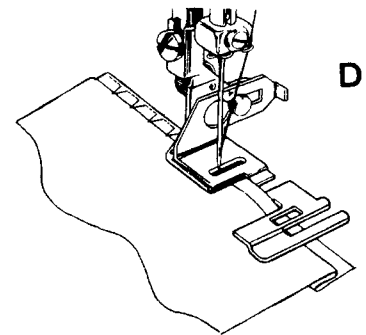
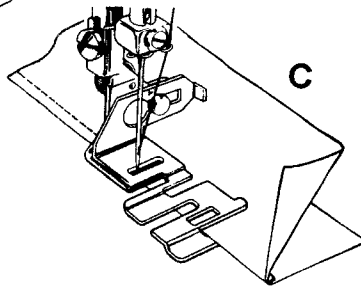
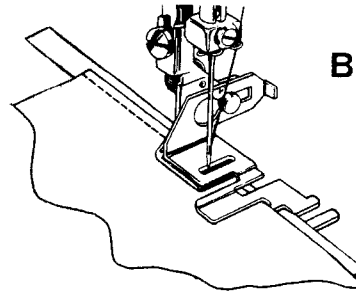
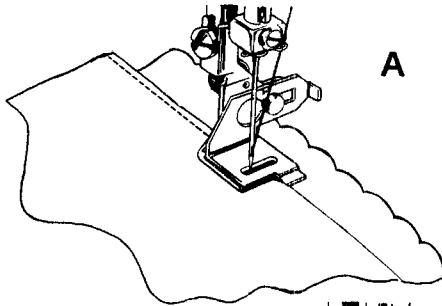

## QUILTING GUIDE

This attachment comes in handy whenever you want several rows of stitches an equal distance apart-for garment trim as well as quilts. The curved prong is shifted back and forth to establish the distance between rows of stitches.

To attach the guide, raise foot release lever and insert it into the hole on the presser foot holder as shown.

## NEEDLE PLATES

You are provided with two needle plates:

- A. Needle plate with wide oval hole for all zigzag stitches and straight stitch with needle at "C" (center) or "R" (right) position.
- B. Needle plate with round hole for straight stitch with needle at "S" (standard) position.

## CHANGING NEEDLE PLATE

1. Raise needle to its highest position and raise presser foot.
2. Remove bobbin cover plate.
3. Remove needle plate by placing thumb under edge of plate and lifting up and out. (See Fig. 2)
4. Make sure bobbin case is in the proper position by turning in the counter-clockwise direction as indicated by red arrow on the bobbin case stopper until it stops. (Fig. 3)
5. Snap desired needle plate into place. (Fig. 4)
6. Replace bobbin cover plate.

### NOTE:

Don't turn hand wheel while needle plate is removed, or needle may hit bobbin case and cause needle damage.

Don't touch screws on the bobbin case stopper.

If bobbin case is not installed as indicated above, it will be damaged when the needle plate is put into position.

## FEED COVER PLATE

There are a few times when you want to control the feeding of the fabric yourself. Raise needle to its highest position and raise presser foot. Place feed cover plate over needle plate aligning two pins of feed cover plate with holes of needle plate. You may then determine the movement of the fabric yourself.

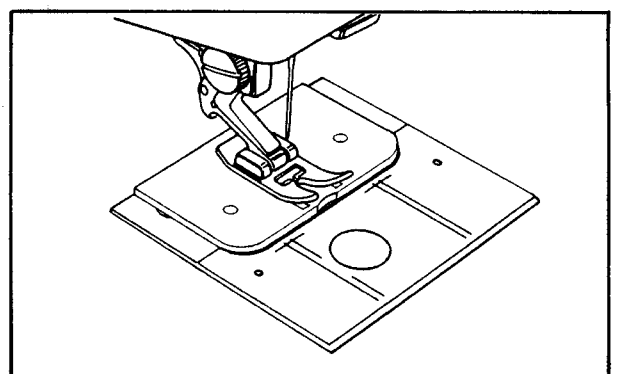
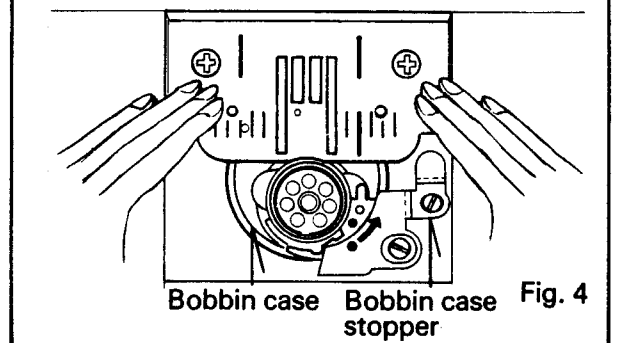
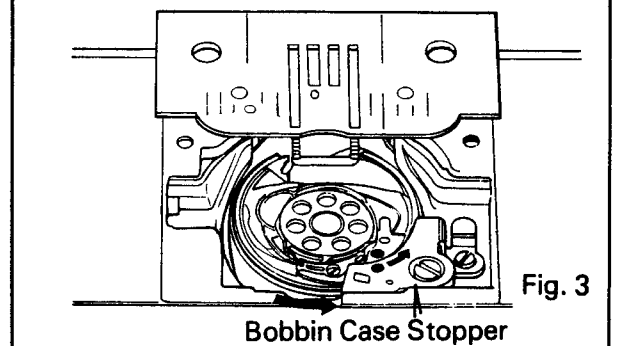
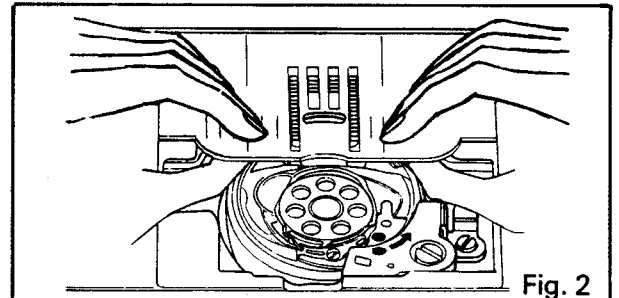
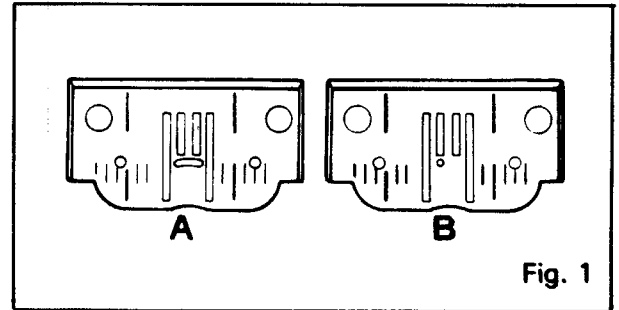

## CARING FOR THE MACHINE

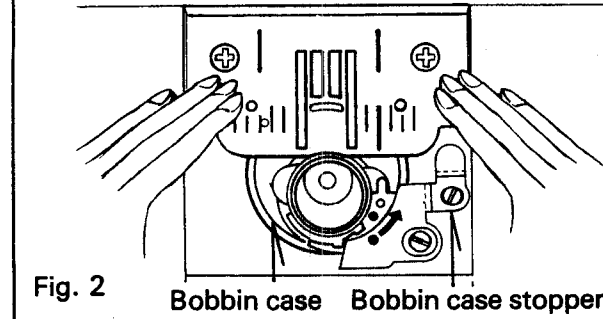
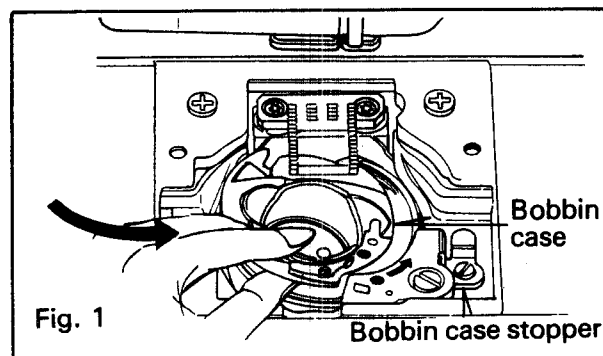
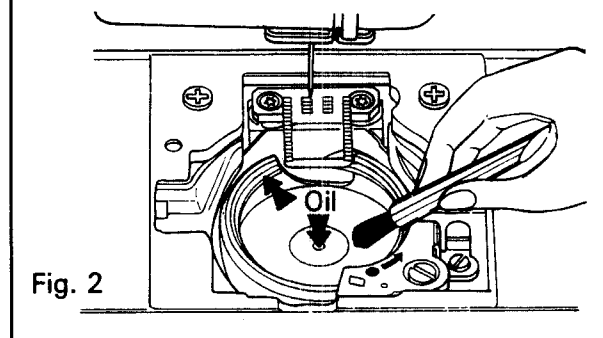
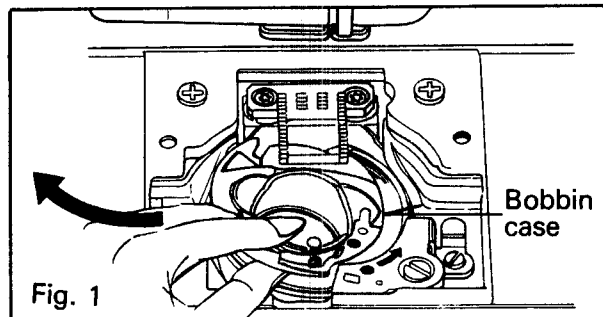
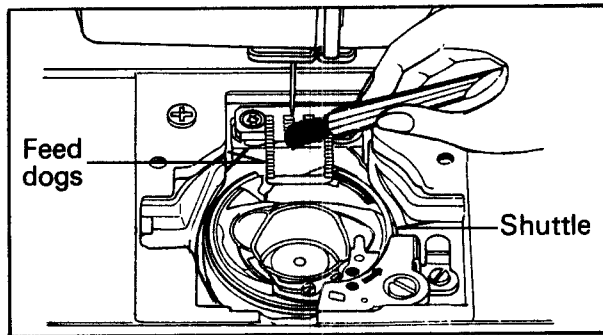

### CLEANING THE FEED DOGS WITH A BRUSH

To insure the best possible operation of your machine, it is necessary to keep the essential parts clean at all times.

Remove bobbin cover plate and needle plate. Using a small brush, remove the lint that accumulates in and around the feed dogs and shuttle area.

### CLEANING AND OILING SHUTTLE AREA

On rare occasions, you may want to clean the shuttle area. Just follow these simple steps.

1. Raise needle to its highest position by turning handwheel toward you. Remove bobbin case by lifting it out from left side.
2. Clean the shuttle with small brush and put a drop of oil to the points indicated by arrows. Don't over-oil. (Reminder: don't use household oil...use sewing machine oil.)

### REPLACING BOBBIN CASE

1. Insert bobbin case into shuttle from left side, aligning red dot on the bobbin case with red dot on the bobbin case stopper. (Fig. 1)
2. Turn the bobbin case in the direction of red arrow on the stopper until it stops. (Fig. 2)
3. Replace needle plate to its original position. (Fig. 2)
4. Replace bobbin cover plate.

NOTE: If bobbin case is not properly installed, it will be damaged when the needle plate is put into position.

Don't touch screws on the bobbin case stopper.

Oil and lint brush No. 6890 is available at most Sears retail stores and catalog.

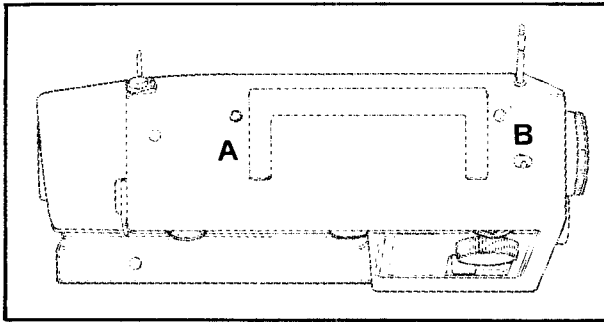

## OILING UNDER TOP COVER PLATE

Remove top cover plate by loosening two top screws (A and B) as shown at left. Then place one or two drops of Kenmore sewing machine oil at each point.

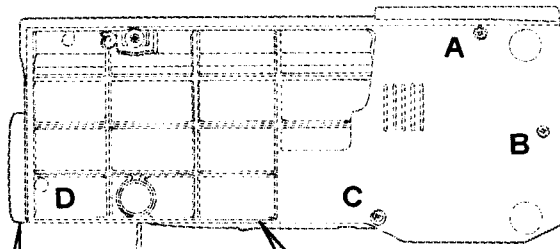
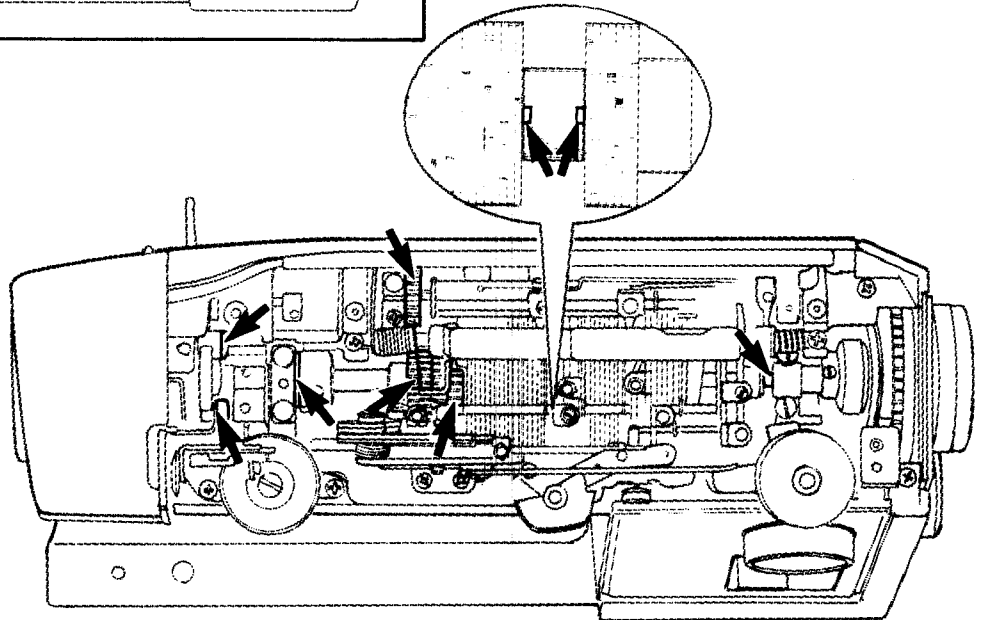

Free-arm cover

Bottom cover

## OILING UNDERSIDE

Tilt back machine and remove bottom and free-arm covers by loosening four screws (A, B, C and D).

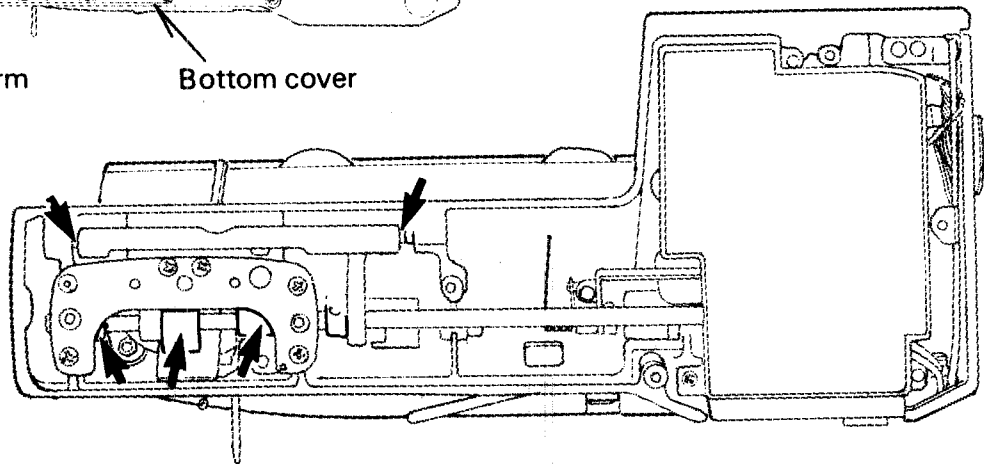

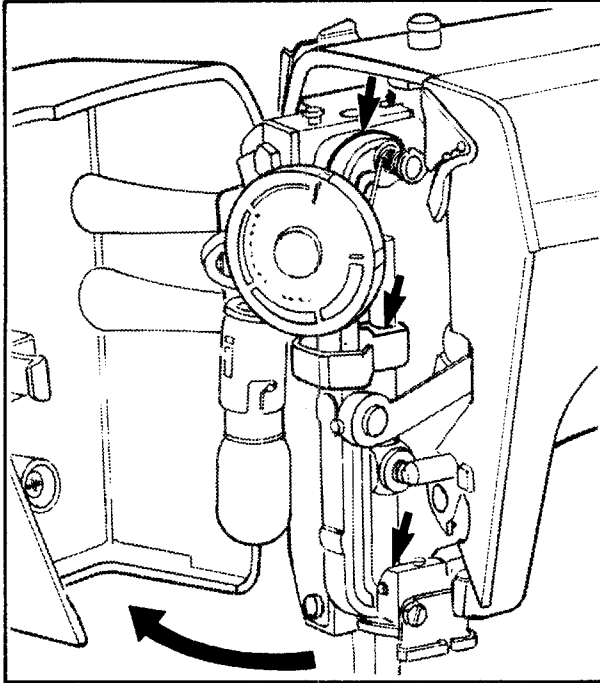

## OILING IN FACE COVER PLATE

Swing face cover plate open and oil points indicated by arrows in illustration.

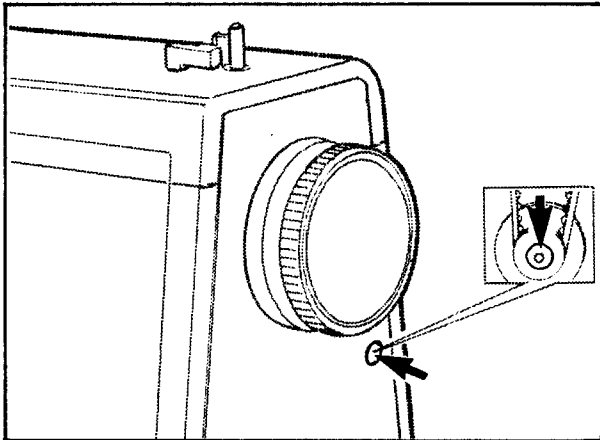

## OILING IN END COVER PLATE

A drop of oil should be placed through the hole indicated in the end cover plate.

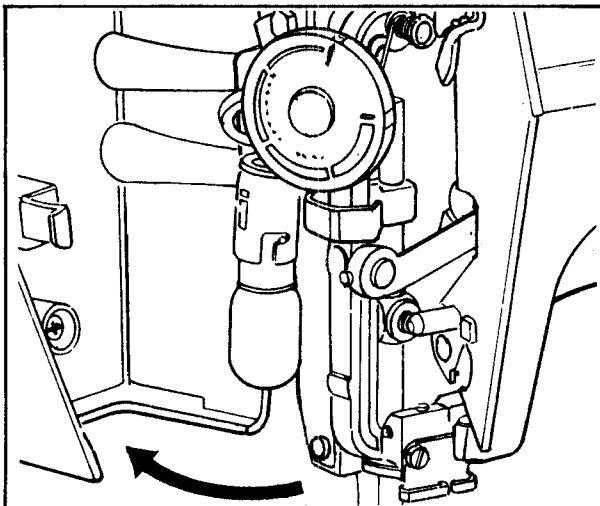

## CHANGING LIGHT BULB

The sewing light is located inside the face cover plate as shown. To replace the bulb, push switch to off, unplug machine and swing the face cover plate open. Push up on the bulb slightly and turn bulb to the left. Withdraw bulb from socket. Push in new bulb and turn to the right.

## CHECKING PERFORMANCE PROBLEMS

Your Kenmore sewing machine is a precision instrument, designed to give you many years of troublefree sewing - with minimum maintenance.

If you have any performance problem, check the list below and you'll be able to solve the problem yourself.

### Stitches are irregular

1. Needle size is not correct for thread and fabric. - See page 16.
2. Machine is not threaded correctly. - See page 10.
3. Top thread tension is too loose. - See page 12.
4. Fabric is being pulled or pushed against machine feeding action. - Guide it gently.
5. Presser foot pressure is too light. - See page 15.
6. Bobbin has not been wound evenly. - Rewind bobbin.
7. There are nicks or burrs at needleplate opening. - Replace needleplate or polish off burrs completely.

### Needle breaks

1. Fabric is being pulled or pushed against machine feeding action. - Guide it gently.
2. Needle size is not correct for thread and fabric. - See page 16.
3. Needle is not all the way up into needle clamp. - See page 17.
4. Presser foot holder is not fastened securely. - See page 17.

### Bunching of thread

1. Top and bobbin threads are not drawn back under presser foot before starting seam. - Draw both threads back under presser foot about 4" and hold until a few stitches are formed.

### Fabric puckers

1. Top thread tension is too tight. - Decrease top thread tension.
2. Presser foot pressure is too light. - See page 15.
3. Two different sizes or types of thread are used. - Use same size and type of thread on top and in the bobbin.
4. Needle is bent or blunt. - Replace needle.
5. Presser foot holder is not fastened securely. - See page 17.
6. Fabric is too sheer or too soft. - Use underlay of tissue paper.

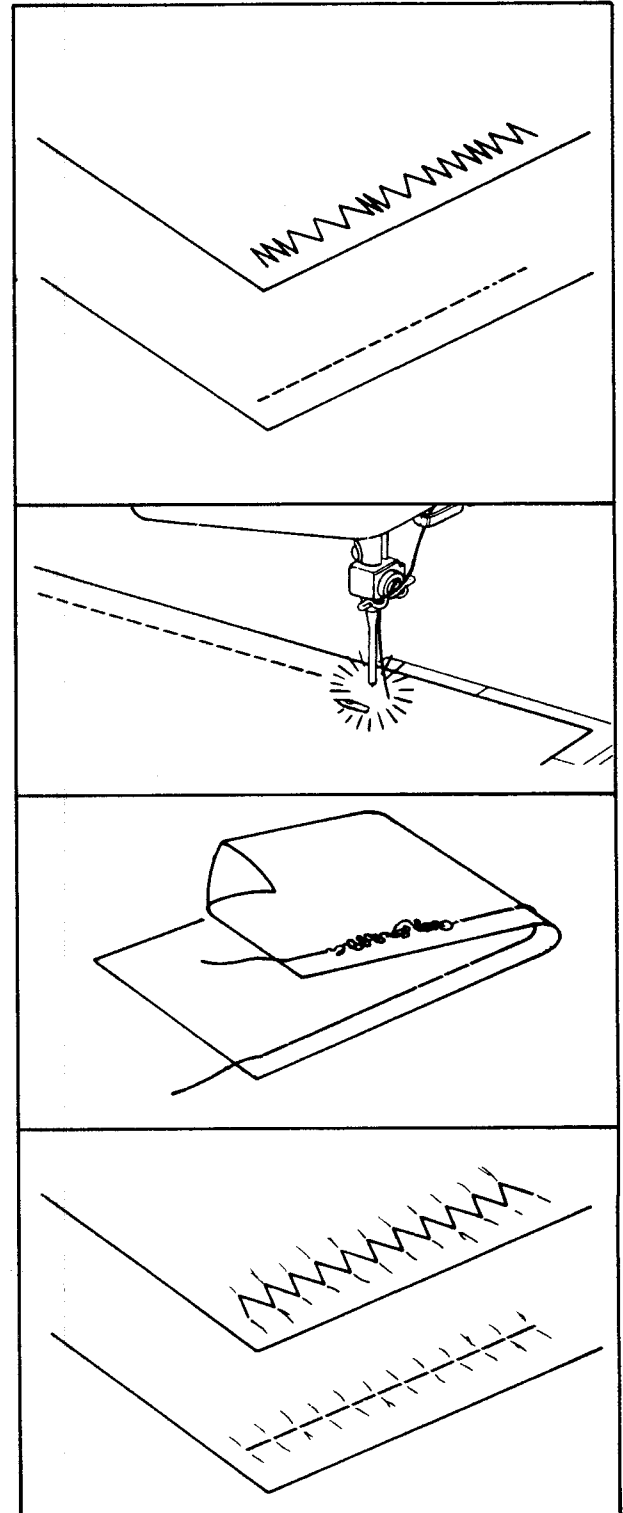

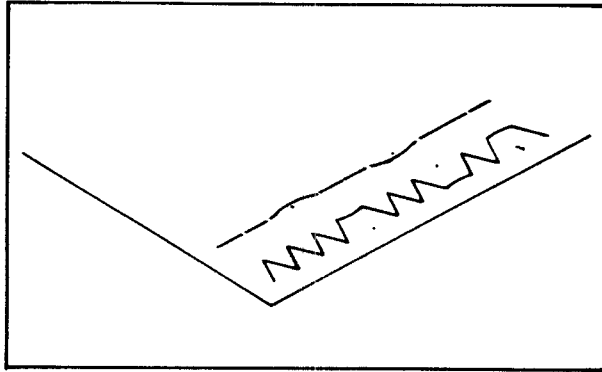

### Machine skips stitches

1. Needle size is not correct for thread and fabric. - See page 16.
2. Fabric is certain knit or synthetic. - Use "Q NEEDLE" and "Q FOOT".
3. Needle is bent or blunt. - Replace needle.
4. Needle is not all the way up into needle clamp. - See page 17.
5. Top thread tension is too tight. - Decrease top thread tension.
6. Presser foot pressure is too light. - See page 15.

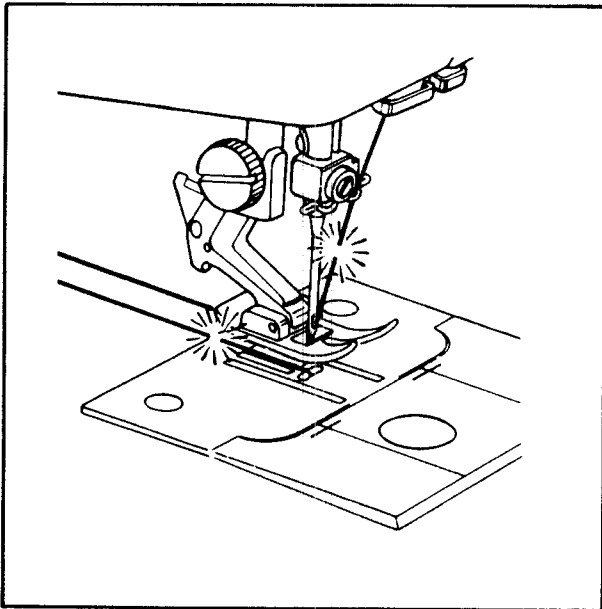

### Needle thread breaks

1. Machine is started too fast. - Start to stitch at a medium speed.
2. Machine is not threaded correctly. - See page 10.
3. Top thread tension is too tight. - See page 12.
4. Needle size is not correct for thread and fabric. - See page 16.
5. Eye of needle has sharp edges. - Replace needle.
6. There are nicks or burrs at needleplate opening. - Replace needleplate or polish off burrs completely.

### Bobbin thread breaks

1. Bobbin case is not threaded correctly. - See page 9.
2. Lint accumulates in bobbin case or shuttle. - See page 21.

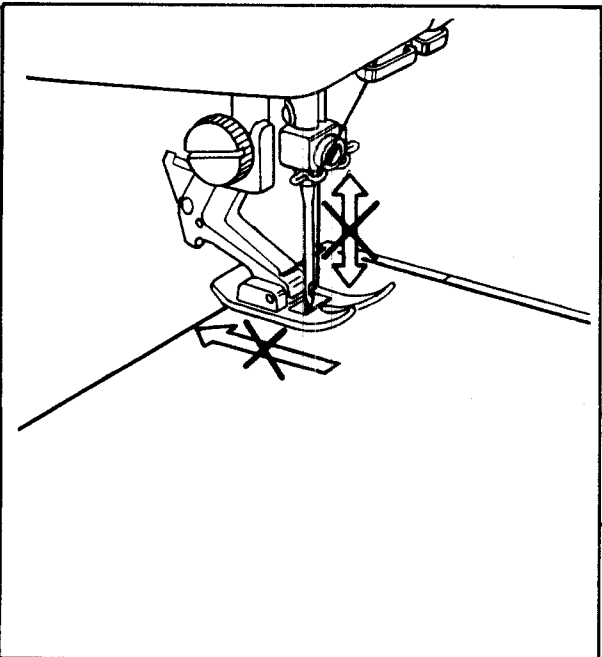

### Machine does not feed fabric

1. Presser foot pressure is too light. - See page 15.
2. Thread is knotted under fabric.
3. Feed cover plate is attached on needle plate. - Remove feed cover plate.

### Machine jams

1. Thread is caught in shuttle. Remove bobbin case and clean shuttle (see page 21).
2. Needle is damaged. - Replace needle.
3. Needle plate is bent. - Replace needle plate.

### Machine will not sew

1. Hand wheel is not returned to stitching position. - Push in clutch.
2. Power cord is not connected. - Check plug.
3. Power/light switch is turned off. - Turn on the switch.

## 2. STARTING TO SEW

Now that you are familiar with the controls on your machine and with the accessories provided for the machine, you are ready to

1. Check the needle-it should be straight, properly set and sharp on the point. It should be the correct size for the fabric and thread being used. Do not be afraid to change your needle frequently. Many of the new fabrics made of synthetic blends tend to dull the needles more easily than fabrics made of natural fibers.



2. Before placing the material on the machine, see that the ends of the threads have been drawn about 3-4 inches to the rear of the machine. Hold on to threads during the sewing of the first 3 or 4 stitches of the seam.

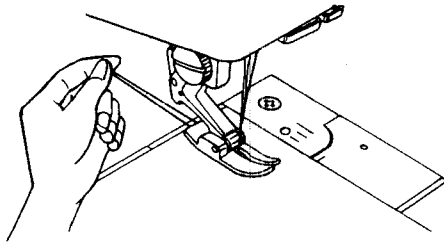

3. Test the machine stitch on a scrap of fabric you plan to use. The fabric should be double thickness. Adjust the machine for the length of stitch and tension suitable to your fabric.
4. Fabric should be placed under the presser foot with the bulk of the material to the left of the needle and the right edge of the material placed on the 5/8" seam marking on the needle plate when making a simple seam.

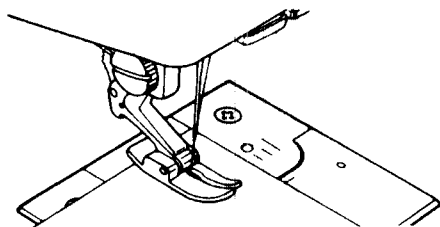

start to sew with your sewing machine. Below are some good habits to follow each time you sit down to sew:

5. Run the machine at a slow even speed. The more pressure you put on the foot control, the faster the machine will sew.

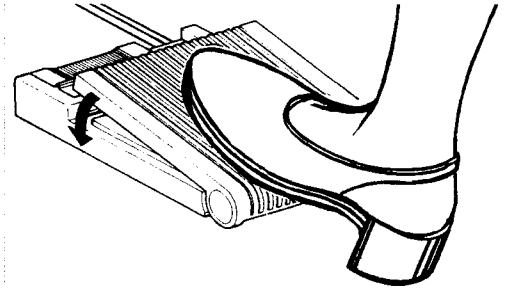

6. Fasten each seam by back tacking at the beginning and end of the seam.

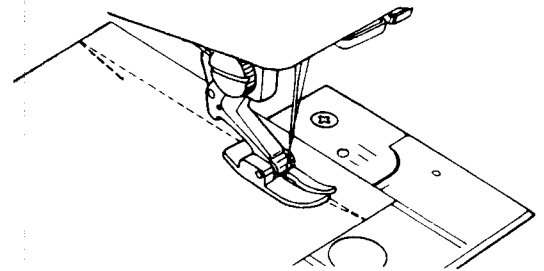

7. Always finish sewing each seam with the needle at its highest point.
8. Guide the fabric gently with your hand in front of the needle. Never pull or hold the fabric in such a way that the normal feeding is altered.
9. When turning the hand wheel manually, always turn it toward you.

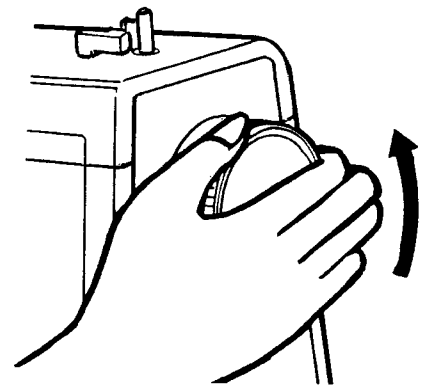

### PRACTICAL STITCH CHART (Model 17922)

A. Straight foot  
 B. Zigzag foot  
 C. Satin foot  
 D. Q foot  
 E. Blind hem foot  
 F. Buttonhole guide foot  
 G. Straight stitch needle plate  
 H. Zigzag needle plate  
 I. Feed cover plate

STITCH	1. INDICATOR	2. LENGTH DIAL	3. STITCH MODIFIER	4. WIDTH/NEEDLE POSITION DIAL	5. PRESSER FOOT	6. NEEDLE PLATE
STRAIGHT STITCH	---	RED ZONE	NEUTRAL	"S" "C" or "R"	A B	G H
ZIGZAG STITCH	~~~~~	RED ZONE	NEUTRAL	RED ZONE	B	H
MENDING STITCH	~~~~~	GREEN ZONE	NEUTRAL	3 - 4	B	H
BOX STITCH	~~~~~	GREEN ZONE	NEUTRAL	2 - 4	B	H
BLIND STITCH	~~~~~	12	NEUTRAL	1½ - 2	E	H
ELASTIC BLIND STITCH	~~~~~	12	NEUTRAL	1½ - 2	E	H
STRAIGHT STRETCH STITCH	=====	YELLOW ZONE	* NEUTRAL	"S" "C" or "R"	A B or D	G H
RICK-RACK STRETCH STITCH	~~~~~	YELLOW ZONE	* NEUTRAL	YELLOW ZONE	B or D	H
FEATHER STRETCH STITCH	~~~~~	YELLOW ZONE	* NEUTRAL	YELLOW ZONE	B or D	H
SMOCKING STRETCH STITCH	~~~~~	YELLOW ZONE	* NEUTRAL	YELLOW ZONE	B or D	H
OVERCAST STRETCH STITCH	~~~~~	YELLOW ZONE	* NEUTRAL	YELLOW ZONE	B or D	H
PARIS POINT STRETCH STITCH	~~~~~	12	* NEUTRAL	2 - 3	B or D	H
DECORATIVE DESIGNS	~~~~~	GREEN ZONE	NEUTRAL	GREEN ZONE	B or C	H
BUILT-IN BUTTONHOLE (Use Buttonholer 7.)	~~~~~	YELLOW ZONE	* NEUTRAL	YELLOW ZONE	B or C	H
DARNING	~~~~~	BUTTONHOLE ZONE	* NEUTRAL	BUTTONHOLE ZONE	F	H
SATIN STITCH	~~~~~	8 - 10	NEUTRAL	"C"	B	H
	~~~~~	BETWEEN 0 AND 24	NEUTRAL	RED ZONE	C	H

\* May need to adjust depending upon type of fabric.

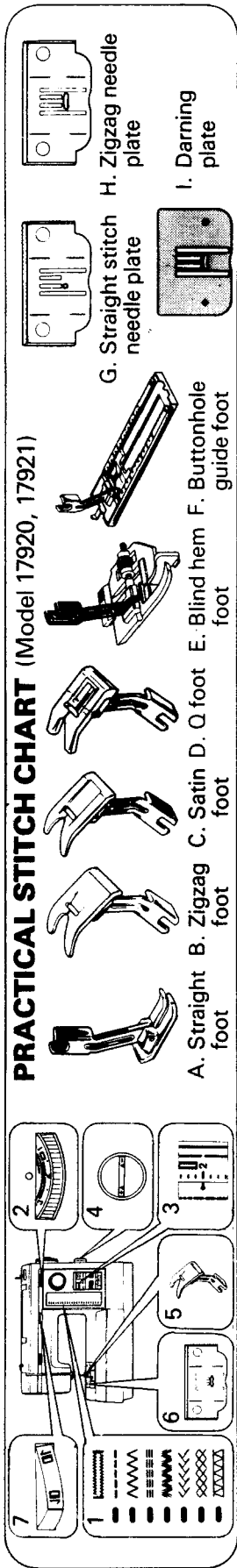

STITCH	1. INDICATOR	2. WIDTH DIAL	3. LENGTH DIAL	4. STITCH MODIFIER	5. PRESSER FOOT	6. NEEDLE PLATE
STRAIGHT STITCH	---	NOT APPLICABLE	RED ZONE	NEUTRAL	A	G
ZIGZAG STITCH	~~~~~	RED ZONE	RED ZONE	NEUTRAL	B	H
MENDING STITCH	~~~~~	3 - 4	GREEN ZONE	NEUTRAL	B	H
BOX STITCH	~~~~~	2 - 4	GREEN ZONE	NEUTRAL	B	H
BLIND STITCH	VVVVV	1½ - 2	2	NEUTRAL	E	H
ELASTIC BLIND STITCH	~~~~~	1½ - 2	2	NEUTRAL	E	H
STRAIGHT STRETCH STITCH	=====	NOT APPLICABLE	YELLOW ZONE	* NEUTRAL	A	G
RICK-RACK STRETCH STITCH	~~~~~	YELLOW ZONE	YELLOW ZONE	* NEUTRAL	B or D	H
FEATHER STRETCH STITCH	<<<<<	YELLOW ZONE	YELLOW ZONE	* NEUTRAL	B or D	H
SMOCKING STRETCH STITCH	XXXXX	YELLOW ZONE	YELLOW ZONE	* NEUTRAL	B or D	H
OVERCAST STRETCH STITCH	ΔΔΔΔΔ	YELLOW ZONE	YELLOW ZONE	* NEUTRAL	B or D	H
PARIS POINT STRETCH STITCH		2 - 3	2	* NEUTRAL	B or D	H
DECORATIVE DESIGNS	~~~~~	4 - 1	GREEN ZONE	NEUTRAL	B or C	H
BUILT-IN BUTTONHOLE (Use Buttonholer (7.))	~~~~~	YELLOW ZONE	YELLOW ZONE	* NEUTRAL	B or C	H
DARNIG	~~~~~	NOT APPLICABLE	NOT APPLICABLE	NOT APPLICABLE	F	H
SATIN STITCH	~~~~~	RED ZONE	BETWEEN 0 AND 1	NEUTRAL	C	H

\* May need to adjust depending upon type of fabric.

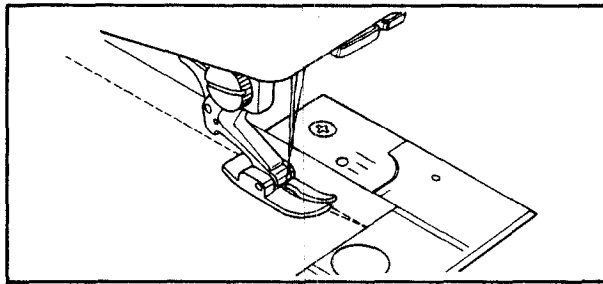

## STRAIGHT STITCHING

\*You may use zigzag, straight stitch foot or Q foot, but for best control of fabric, best looking straight stitches and best feeding of fabric use **Straight Stitch Foot and Needle Plate**.

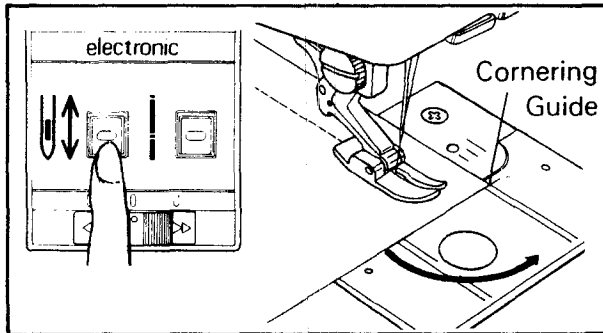

## FASTENING A SEAM

Be sure both threads are drawn back under the presser foot. Lower needle into fabric about 1/2 inch from beginning of seam. Depress the reverse stitch lever and stitch in reverse until needle reaches beginning of seam. Release control and complete seam. When you reach the end, depress the reverse stitch lever and sew back (backtack) over 1/2 inch of completed seam.

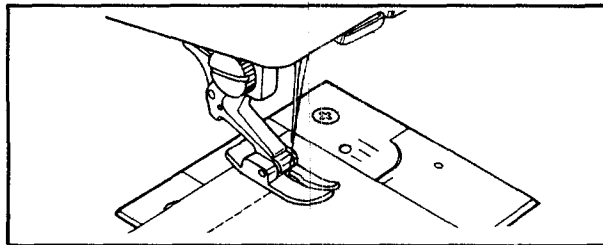

## TURNING A SQUARE CORNER

1. To turn a square corner 5/8" from the fabric edge, stop stitching when reaching the **cornering guide** and push **needle up/down switch** to lower the needle into the fabric.
2. Raise the presser foot and turn fabric. New stitching line will align with 5/8" seam guide on side of needle plate. Lower the presser foot and begin stitching in new direction.

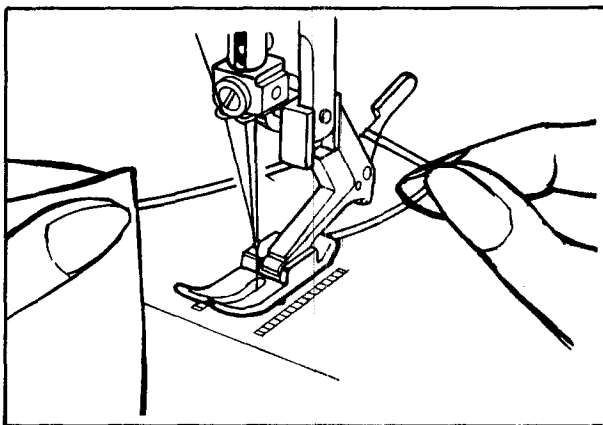

## REMOVING FABRIC

First turn the handwheel toward you until the needle is at its highest position, then raise the presser foot, draw materials to the rear and cut off excess thread with the thread cutter located on the presser bar as shown.

## DARNING

### SETTINGS

Stitch Length - 8 to 10  
Pressure Regulator - 0 (DARN)  
Zigzag foot or square automatic buttonhole foot

Stretch fabric between embroidery hoops with hole centered. Lower presser bar and sew at a slow speed moving fabric back and forth with a steady rhythm to cover darning area. When it is covered, turn fabric 1/4 a turn and sew layer of stitching across first layer.

If fabric is thin or badly damaged in hole area, you may want to put a separate piece under the hole for reinforcement.

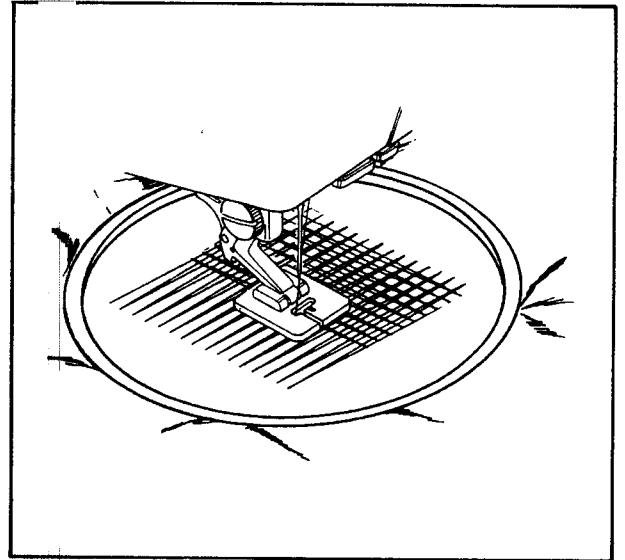

## TEMPORARY SEWING BY MACHINE

Regular basting by machine is easy – simply use **straight stitching** with longest available **length setting**. And your machine has a free basting method for very long stitches that sometimes can be used for “marking”.

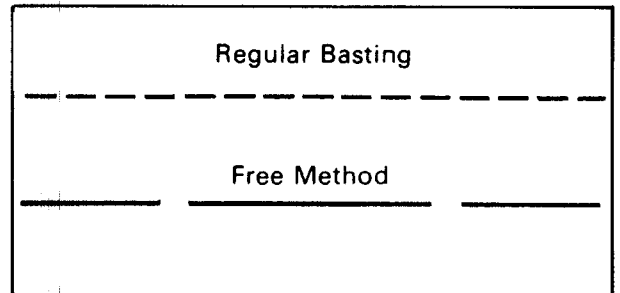

## FREE BASTING METHOD

### SETTINGS

Basting switch - turn on  
Pressure regulator - 0 (DARN) or 1  
Use feed cover plate.

Tap the foot control and the machine will take one stitch and stop automatically with the needle in the up position. Holding the fabric in both hands, pull it back to the required stitch length.

Repeat this process, tapping down on the foot control and guiding the fabric with your hands.

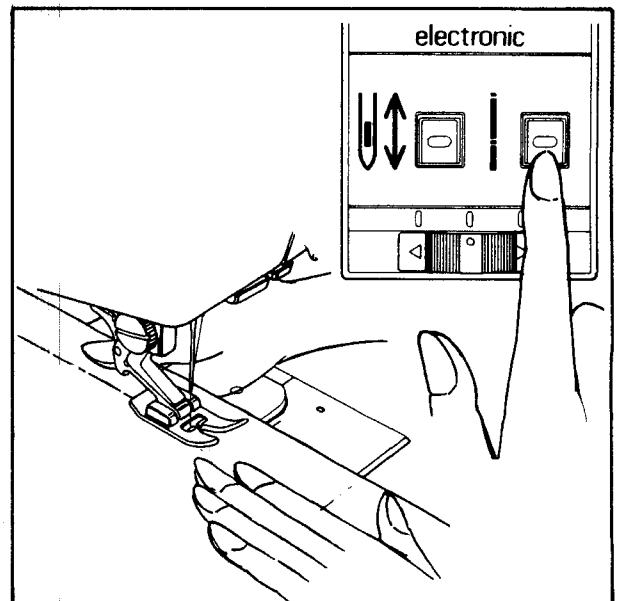

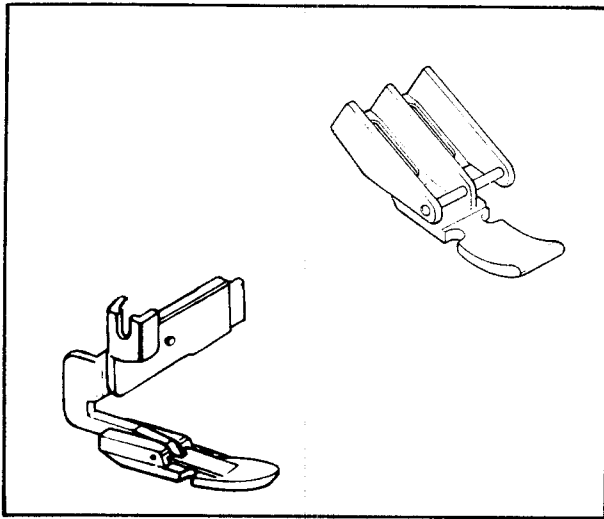

## ZIPPER APPLICATION - CORDING

Home-sewn zippers can look as nice as those on expensive ready-mades. We recommend you follow directions given on zipper package. Your Zipper Foot will assist you with any of these installations. Use these simple settings:

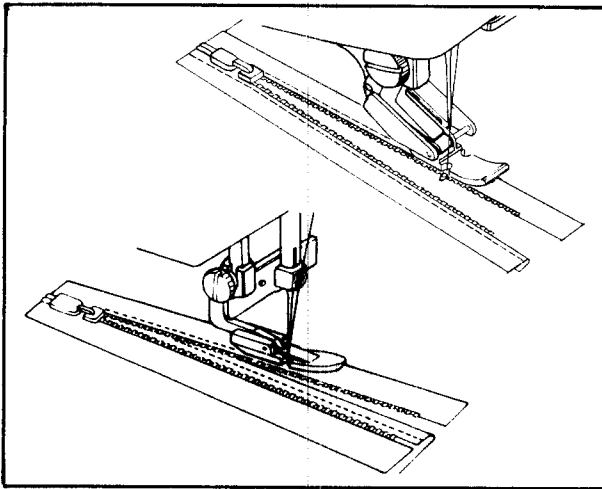

Your zipper foot is adjustable for use on right or left side of needle. Adjust foot so needle clears side notch on foot. Then proceed according to zipper manufacturer's instructions.

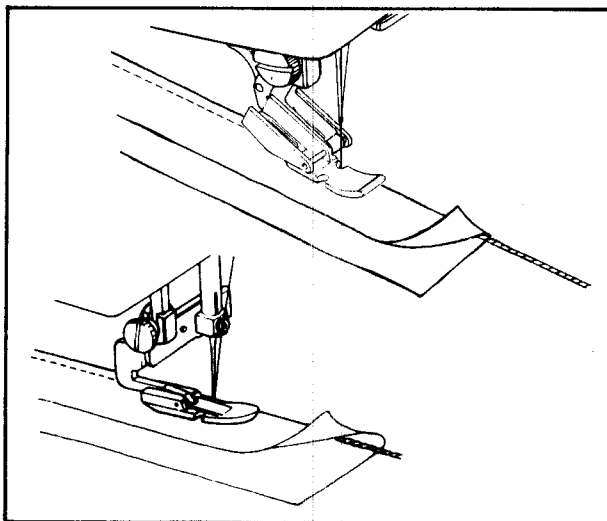

Your zipper foot also makes it easy to add "cording" to garments as well as slip covers, toss pillows, bedspreads, decorative pieces. Cut fabric on **bias** and wrap around cord. Pin fabric in place so seam edges are even. With zipper foot to **left** of needle, stitch close to cord.

## NARROW HEMMING

Attach the Narrow Hemmer to the adjustable holder. Make sure that edge of the fabric is cut straight. Turn a tiny double hem ( $\frac{1}{8}$  inch) along edge for about two inches. Place end of this hem under Narrow Hemmer. Hold thread taut while stitching along inside edge of hem. Feed fabric gradually into "scroll" in hemmer, guiding edge of fabric as shown.

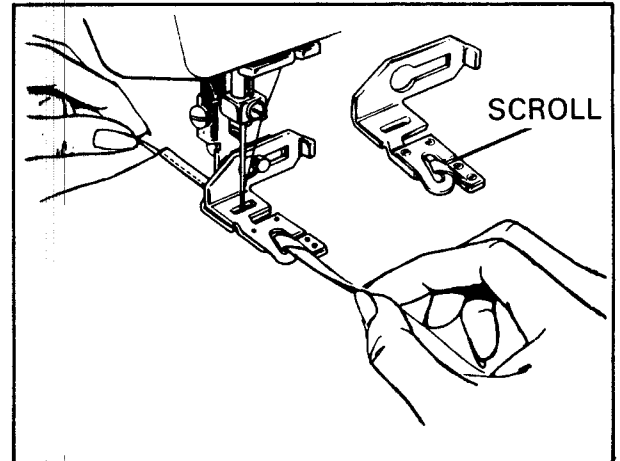

## QUILTING

Attach the quilting guide to presser foot as shown. After completing the first row of stitching, place the guiding prong on this stitched line. The second row then can be placed at the desired distance from first row. Continue working in this way for as many rows as you want.

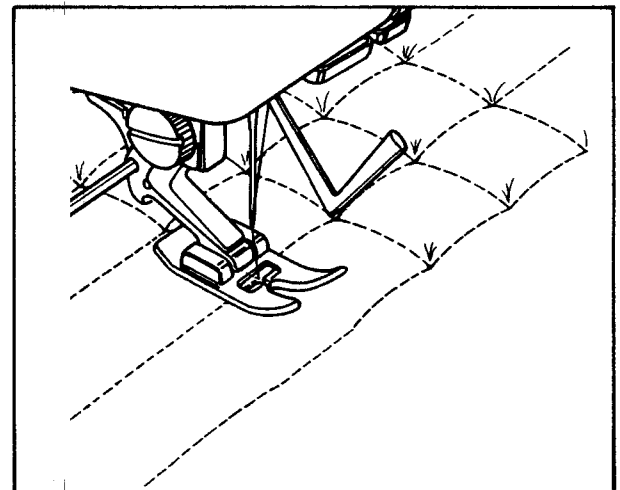

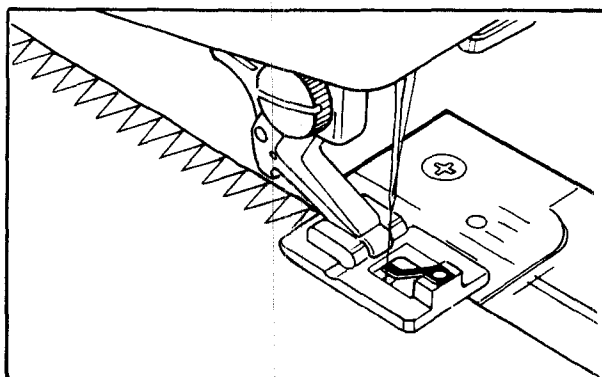

## ZIGZAG STITCHING

### OVERCASTING

Stitch Selector -   
 Stitch Length - 12 - 8  
 Stitch Width - 3 - 4  
 Use Overcast Foot.

This is one of the more frequently used zigzag stitches on garment construction. You may want to overcast along the raw edge of each seam allowance or fold the raw edge toward the garment and stitch.

Stitch so the needle pierces the fabric just short of the outside edge. Raw or worn edges of older garments can be overcast to prevent further raveling.

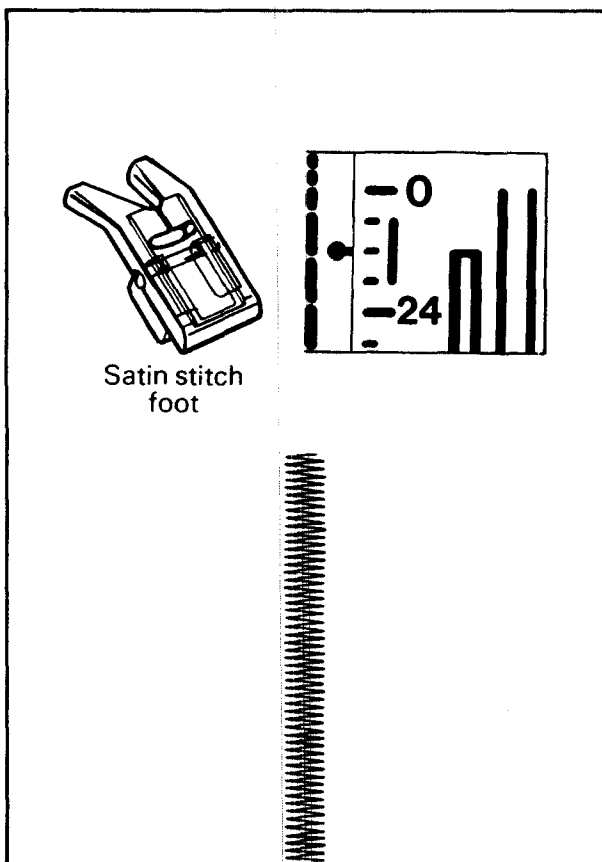

### SATIN STITCHING

Stitch Selector -   
 Stitch Length Dial - Between 0 and 24 (—)  
 Use metal or plastic Satin stitch foot which is grooved to permit dense stitching to pass under it easily.

Closely spaced zigzag stitches are called satin stitches. This is an attractive stitch used for appliqueing, bar tacking.

Whenever you are using this stitch, it is well to remember to loosen the tension of the top thread slightly. The wider the stitch you make, the looser the tension should be.

If you are stitching on a very soft fabric, use a backing of tissue paper or interfacing for a well formed stitch. Puckering of the material will be eliminated and the bobbin thread will not be visible on the right side of the fabric.

As with all special stitches, it is best to make a sample design on your fabric before starting the design on the garment.

### BAR TACKING

Settings same as Satin Stitching

This stitch is similar to a very short satin stitch and is used to reinforce points of strain such as corners of pockets and straps on lingerie.

Sew 4 to 6 zigzag stitches.

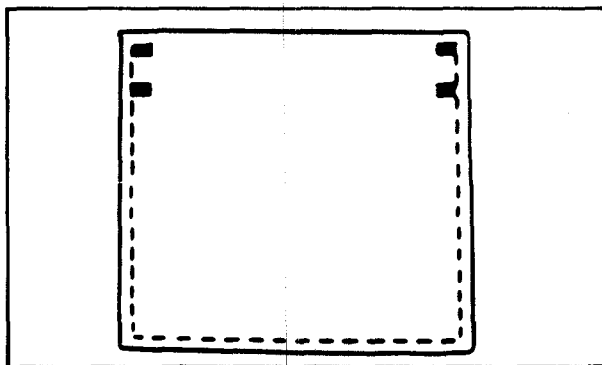

## APPLIQUEING

Settings same as Satin Stitching

Select an applique design to be applied to your garment and baste it in place. Satin stitch around the raw edge of the applique completely covering the edge. You may want to do this with a contrasting color of thread.

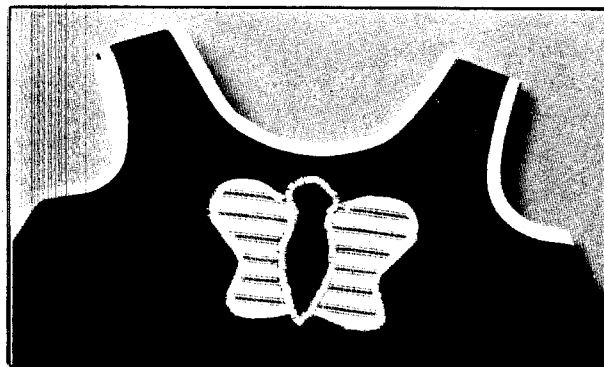

## EMBROIDERY

Settings same as Satin Stitching

Satin stitch can be used to produce many different designs and patterns. To sew the flowers illustrated, back the fabric with interfacing or paper and draw on the design with tailor's chalk. Turn the stitch width control from 0-4-0 to from each petal and leaf. Join the flowers and leaves with straight stretch stitch. If using paper, carefully remove it when you have finished sewing.

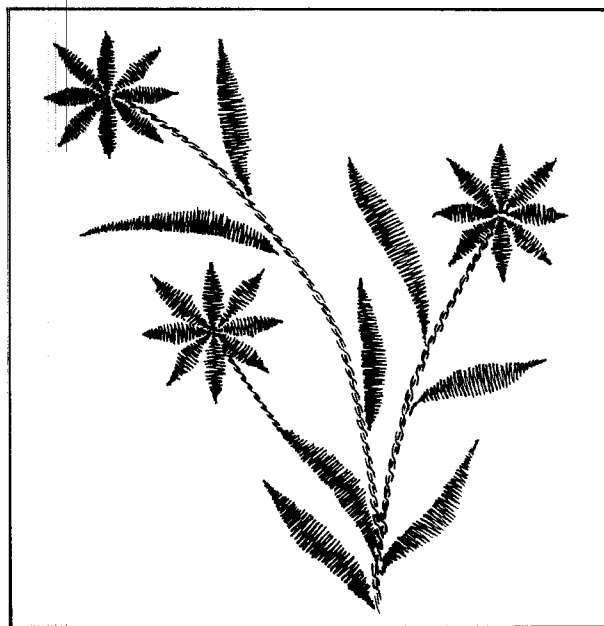

## MONOGRAMMING

Settings same as Satin Stitching

To sew initials, first back the fabric with interfacing or paper. Draw the initials on to the fabric with tailor's chalk. Satin stitch, adjusting the width from 0-4 as you begin and end the stroke of a letter. Or the same stitch width can be used throughout. If using paper, carefully remove it when you have finished sewing.

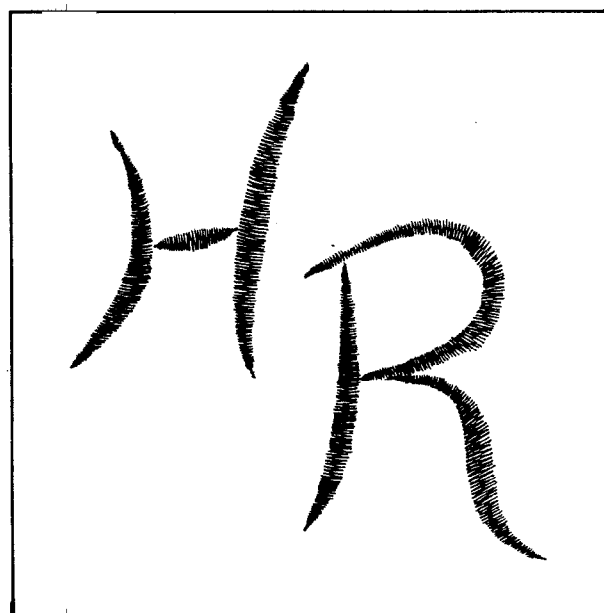

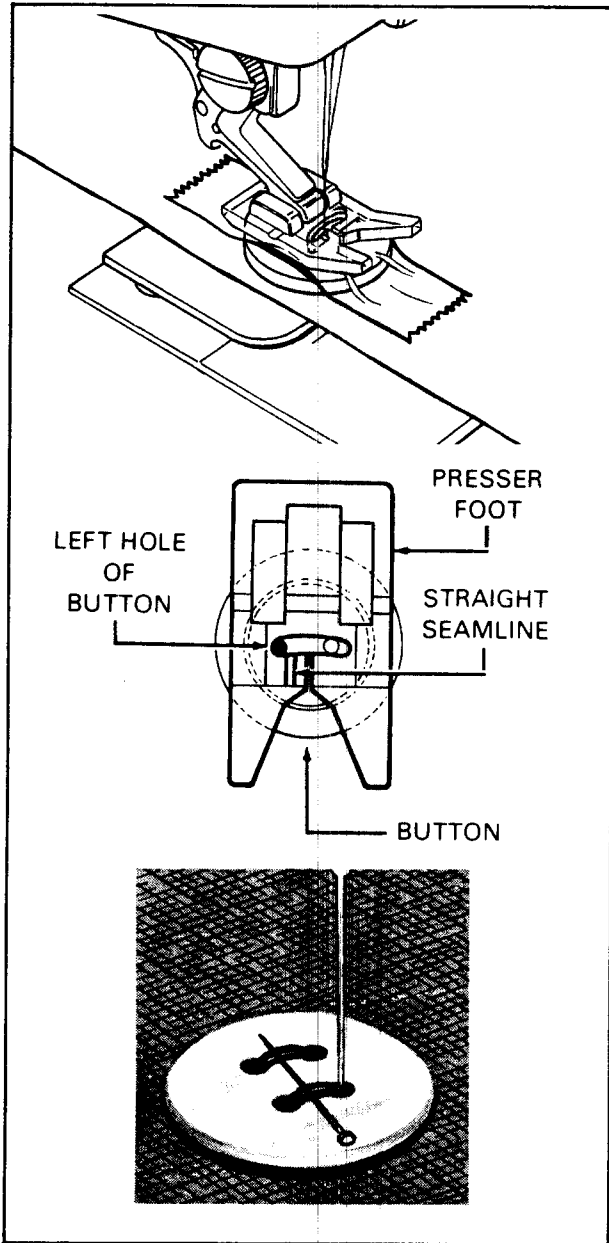

## BUTTON SEWING

Stitch Selector - 

Stitch Width - Adjust to Button Size

Use Feed Cover Plate and Clear Plastic Satin Stitch Foot.

1. Position the button on fabric with clear tape.
2. Center the left hole of button between straight seamline and the left edge of needle slot of foot and lower foot to hold the button securely.
3. Turn hand wheel manually until needle point is just above button.
4. Adjust stitch width control so needle will enter right hole of the button.
5. Turn hand wheel again by hand so needle enters second hole. Readjust stitch width if necessary. Stitch a number of times.
6. Finish sewing with an extra two inches of thread remaining. Draw these threads to reverse side of garment and tie.

When sewing a flat button, place needle or pin between holes of button as shown to provide flexibility for buttoning.

## BLIND HEMMING

- ∩∩∩∩ – Regular blind stitch for normal fabrics
- ~~~~~ – Elastic blind stitch for soft, stretchable fabrics

Blind hemming is a good technique to use on garments, and especially on curtains and drapery hems so that stitches need not show on the front of the fabric. Because your Kenmore has two types of blindstitches built in, blind hemming is easier than you'd expect. It's just a matter of folding... give it a try!

### PROCEDURE

Stitch Length - 12  
Stitch Width - 1½ - 2

1. Finish raw edge of fabric appropriately. You may want to use seam tape on woven fabrics. With knits use a lace seam tape or just use decorative stretch stitch.
2. Working on **wrong** side of fabric, fold hem **up**. Press and pin in place. Then fold hem allowance **under**... leaving 1/8" of hem edge extending.
3. Place garment under blind stitch foot with the fold of the garment against guide and slide it by turning screw so that the zigzag just catches the fold. (Blind hemming can be simplified by also using the special Kenmore Edgestitcher—please refer to 19 for details.)
4. Now the **right** side of your garment will show only the blind stitches! Be sure to press both sides of the finished hem!

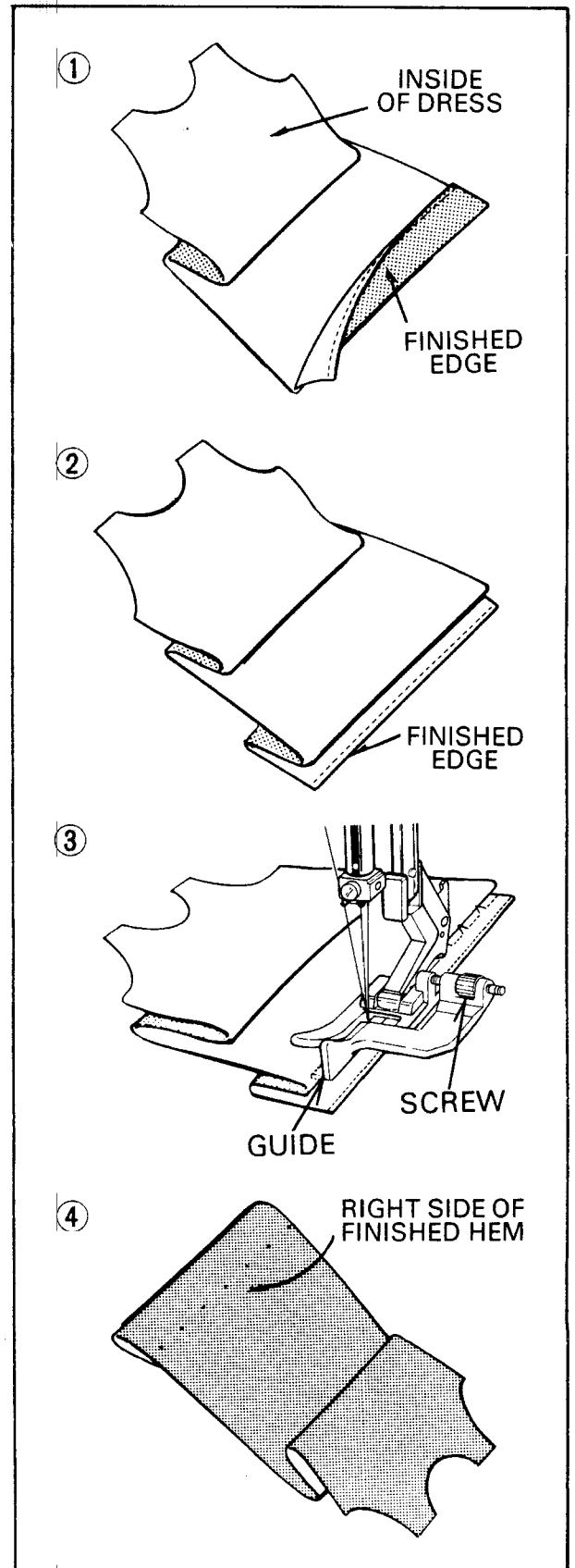

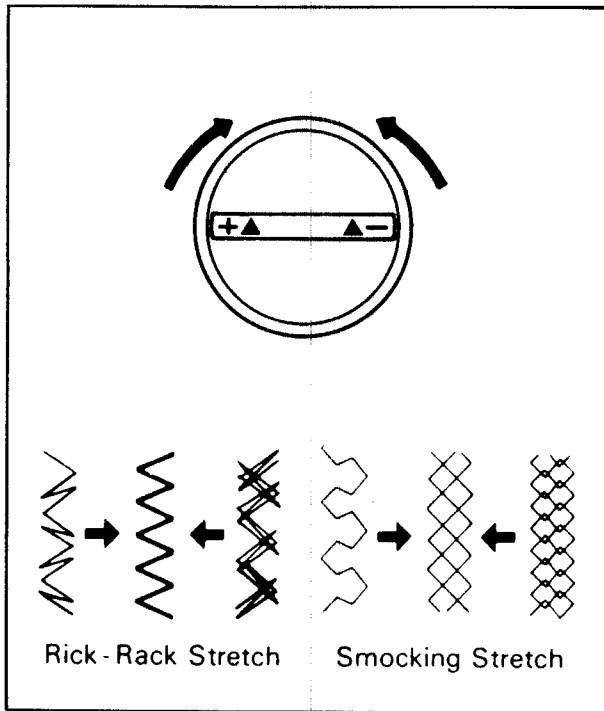

## STRETCH STITCHES

Stretch stitches, as their names imply, are mainly for use on stretch and knit fabrics such as stretch nylon, stretch towelling, jersey and cotton jersey; and for sewing together knitted garments. Stretch stitches are also often used on non-stretch fabrics.

### ADJUSTING STRETCH STITCH BALANCE

Stitch modifier should be in neutral (notched) position for most materials. Depending upon the type of fabric used, you may need to adjust this control to match forward stitches of stretch sewing with reverse motion stitches. If the stitches are too open, turn the control slightly clockwise; if the stitches overlap, turn the control counter-clockwise.

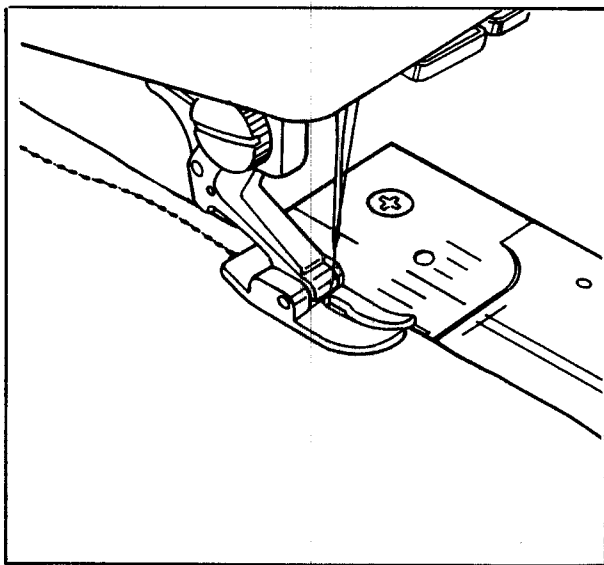

## STRAIGHT STRETCH STITCH

### SETTINGS

Stitch Selector - ≡≡≡≡≡

Stitch Length - Yellow Zone

Stitch Width - Any number (not necessary to adjust)

You may use either a zig zag or straight stitch foot BUT-- for best control of fabric, best looking straight stitches and best feeding of fabric use **Straight Stitch Foot** and **Straight Stitch Needle Plate**.

Use this stretch stitch with knit or synthetic fabric. Sew as you do with regular straight stitch.

This is also a good stitch to use on curved seams regardless of the type of fabric. Any seam that will receive a great deal of strain when worn should be sewn with the stretch stitch. Use in children's shorts and slacks as well as adult sports clothes.

### RECOMMENDATION

1. It is recommended you use the Q set for sewing knit and woven synthetic fabrics.
2. It may be necessary to use an interfacing or backing when sewing very soft and thin knits or woven synthetic fabrics.

## RICK-RACK STRETCH STITCH

Stitch Selector -   
Stitch Length - Yellow Zone  
Stitch Width - Yellow Zone

Sew on stretch fabrics in any area that you might use a zig zag stitch. This stitch can be used as a decorative top stitch as well.

It is useful also on lapped or abutted seams where you lap one edge of a seam over another with seamlines meeting in the center.

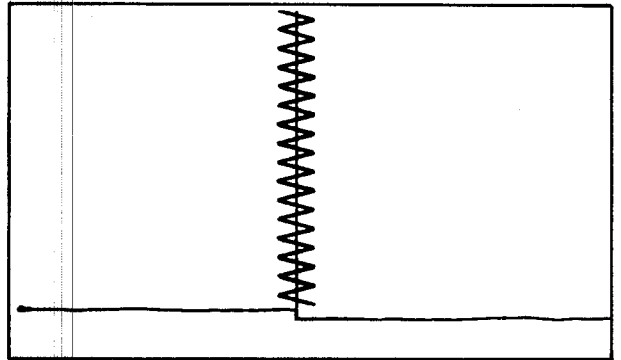
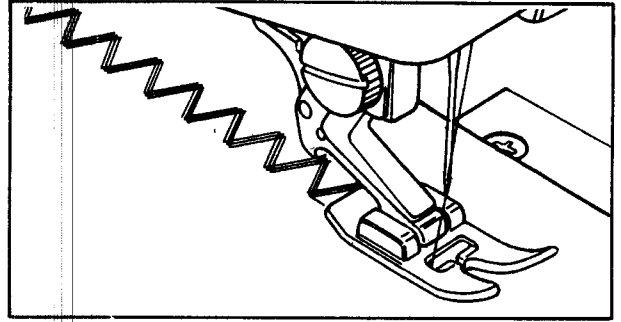

## FEATHER STRETCH STITCH

Stitch Selector -   
Stitch Length - Yellow Zone  
Stitch Width - 2 - 4

This is a good stitch to use with laces, on lingerie, bra and girdles; and to apply bias tape. It's great when quilting.

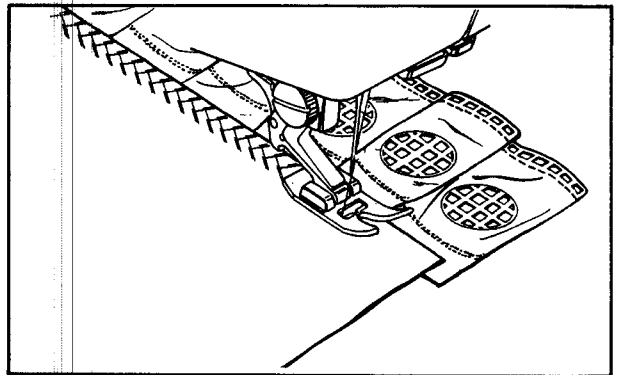

## SMOCKING STRETCH STITCH

Stitch Selector -   
Stitch Length - Yellow Zone  
Stitch Width - 2 - 4

1. Make a straight line of gathers across the fabric that you wish to smock.
2. With a narrow strip of fabric directly under the line of gathering, stitch over the gathers. The design will be a series of small diamonds.

Note: When smocking a garment, the stitching should be done before the piece is sewn into the garment.

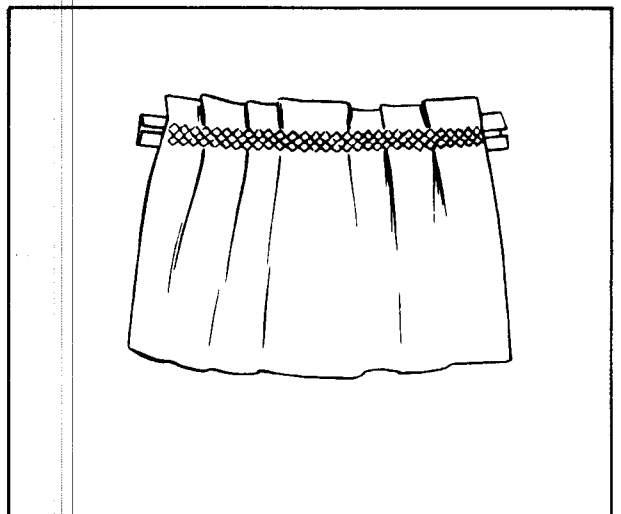

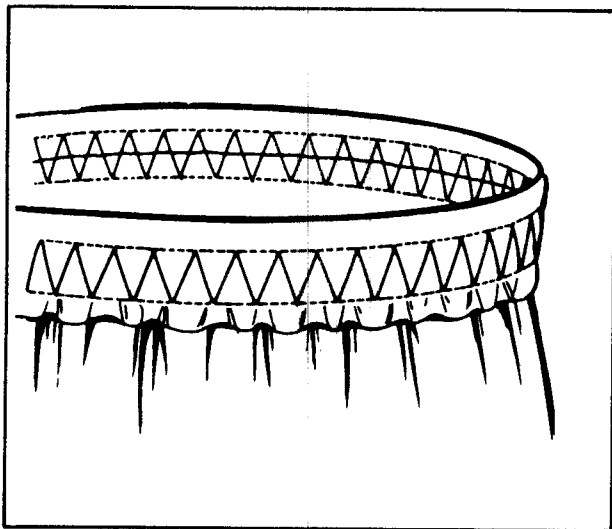

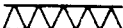

## ELASTIC STRETCH STITCH

Stitch Selector -   
 Stitch Length - Yellow Zone  
 Stitch Width - 2 - 4

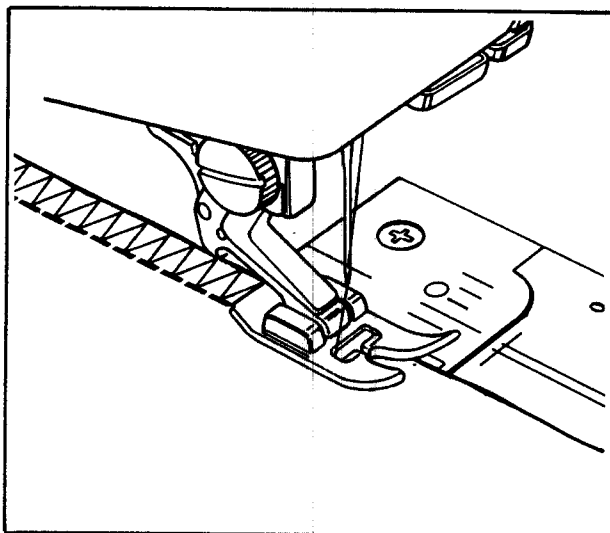
Use this versatile stitch to insert elastic in garments. Simply stitch elastic into place, making sure it is evenly spaced. To do this, mark the correct length piece into quarters, then match these markings with center front and side seams.



## OVERCAST STRETCH STITCH

Stitch Selector -   
 Stitch Length - Yellow Zone  
 Stitch Width - 4

This is the same type stitch used by the garment industry in making sportswear-it forms and finishes the seam in one operation (for seams of  $\frac{1}{4}$ " to  $\frac{3}{8}$ "). It's very effective for use in repairing raw or worn edges of older garments.

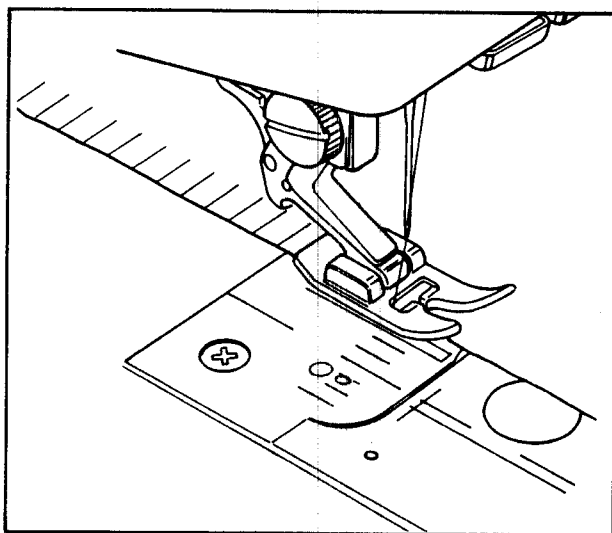

## PARIS POINT STRETCH STITCH

Stitch Selector -   
 Stitch Length - 12  
 Stitch Width - 2-3

Excellent for hemstitching table and bed covers with a elegant touch. Picot-like stitch can also be made on sheer materials. Sew along the raw edge of fabric and trim close to the outside of the stitching.

## BUTTONHOLE MAKING - BUILT-IN SYSTEM

### PREPARATION

Carefully mark the buttonhole length on your garment. Place the fabric with the buttonhole marked under the buttonhole foot. Pull the guide foot (A) all the way forward so that the index mark (B) is aligned with the graduation (C), with thread to rear. (Reproduction of the identical size buttonholes is facilitated with the aid of the graduations on the both sides of the buttonhole guide foot. These graduations are 1/8" (left side) or 2.5 mm (right side) apart. Graduations act as reference mark.)

### PROCEDURE

1. Switch the control to left. (If it has been already at left, set it at right, sew several stitches and switch to left again.) Step on foot control to form first bartack and left side of buttonhole.
2. When you reach end of left side, switch the control to the right and complete the buttonhole.

### ADJUSTING STITCH BALANCE

Stitch length differences in forward and reverse stitches of the buttonhole are equalized with the stitch modifier.

If the reverse stitches are too far apart, turn the modifier slightly clockwise; if they are too close together, turn counter-clockwise.

### CORDED BUTTONHOLES

Hook filler cord (crotchet thread or buttonhole twist) to the spur (A), pull both ends of cord forward under foot and tie to the spur (B). Sew buttonhole in such a way that zigzag stitches cover the cord.

When stitching is completed, release cord from foot, pull ends of cord and snip off extra length.

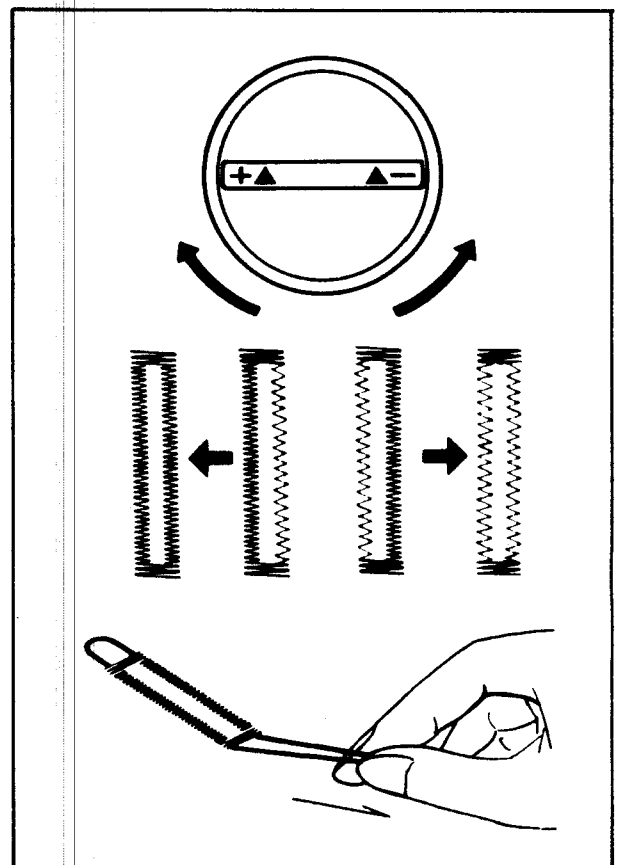
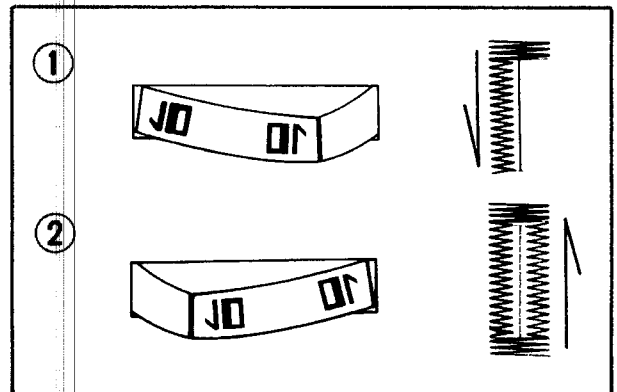
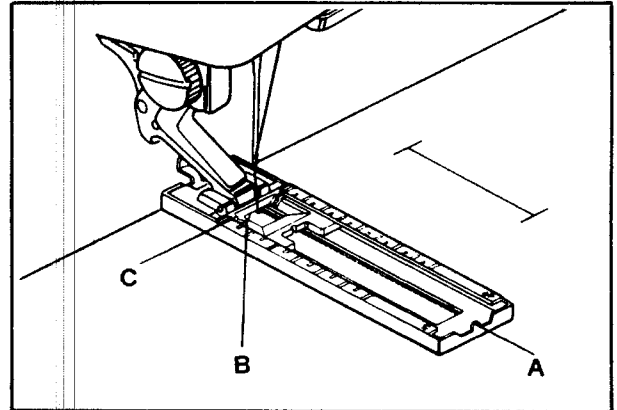
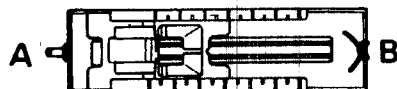

## BUTTONHOLE MAKING - USING BUTTONHOLE ATTACHMENT

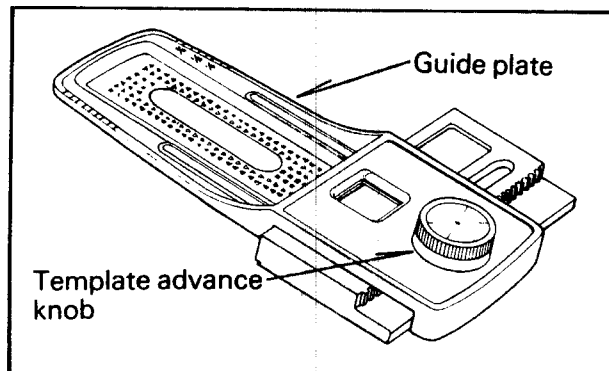
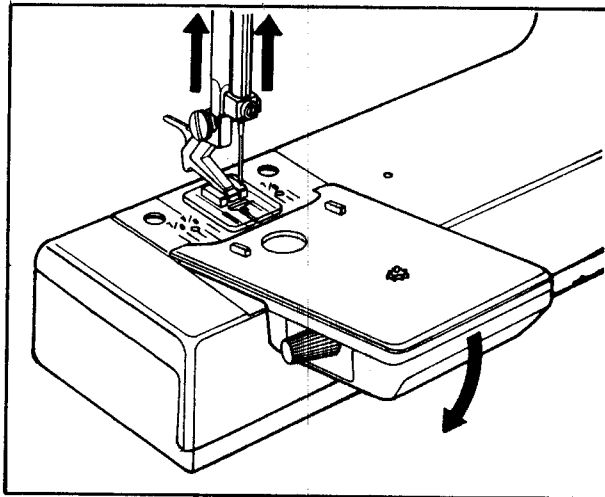
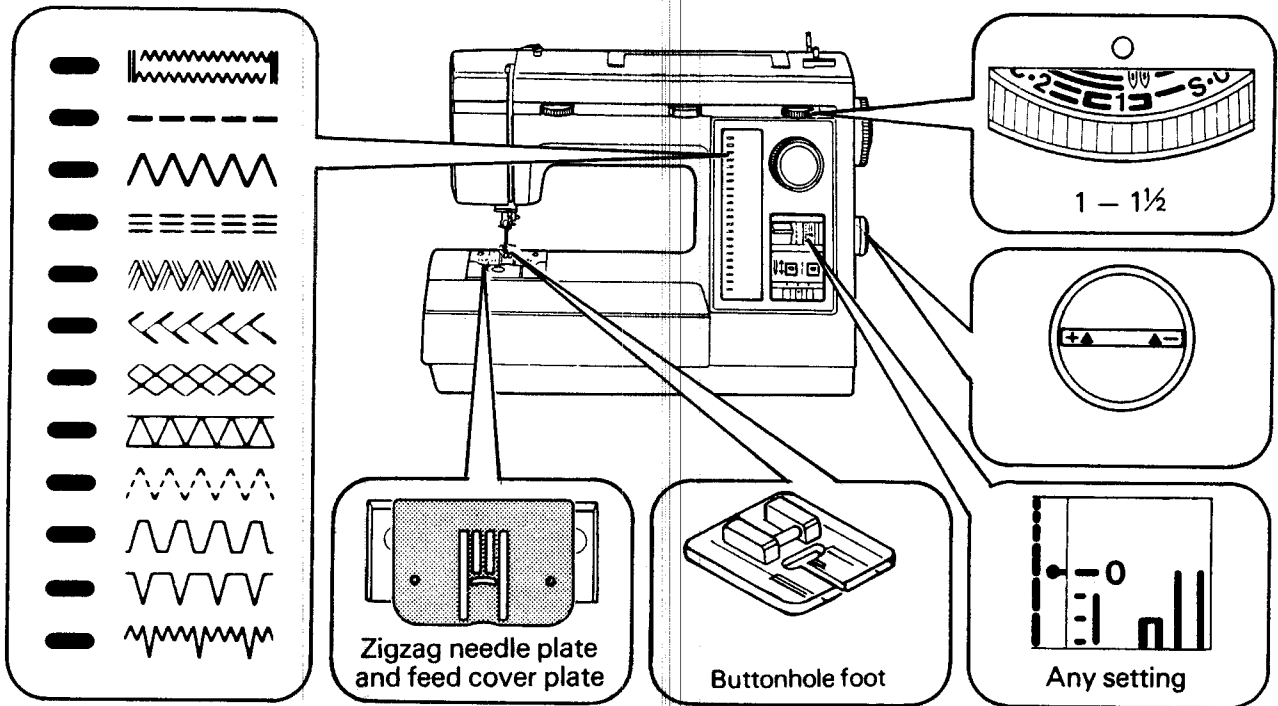

### REGULAR WORKED BUTTONHOLE (STRAIGHT, KEYHOLE AND EYE-LET)

#### PROCEDURE

Stitch Selector -   
 Stitch Width - 1 - 1½  
 Zigzag Needle Plate  
 Feed Cover Plate  
 Buttonhole Foot

1. Raise needle to its highest position and raise presser foot. Remove accessory box and bobbin cover plate.  
 Insert buttonhole cover plate at **45 degree angle** and snap it down into place pressing it against the needle plate.
2. Select correct template for type buttonhole you want. Insert template into slot of guide plate. Turn template advance knob until desired size appears in window on the top side of guide plate.

3. Slip guide plate onto machine so it fits in place with **pinion gear** in the center of arc hole of template. Be sure guide block is inserted in guide slot.

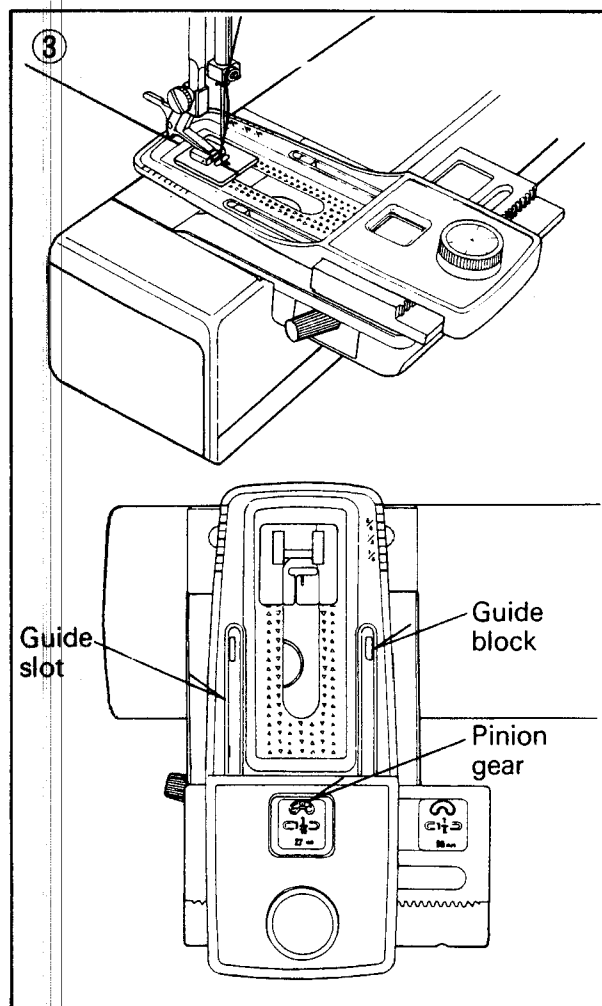

4. Pick up bobbin thread through guide plate by turning hand wheel. Place fabric between presser foot and guideplate. Align marked buttonhole with **cut-out** of foot. Line up edge of fabric with markings on guideplate. If you wish all buttonholes to be  $\frac{3}{4}$ " from edge of garment, for example, line up fabric with  $\frac{3}{4}$ " marking each time you start a buttonhole.

Now you're ready to stitch the shape you've selected—straight, keyhole or eyelet. Your template will guide you.

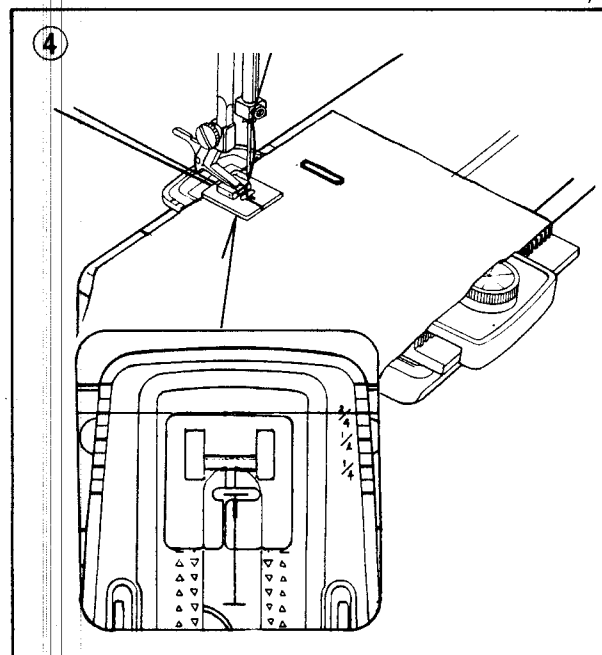

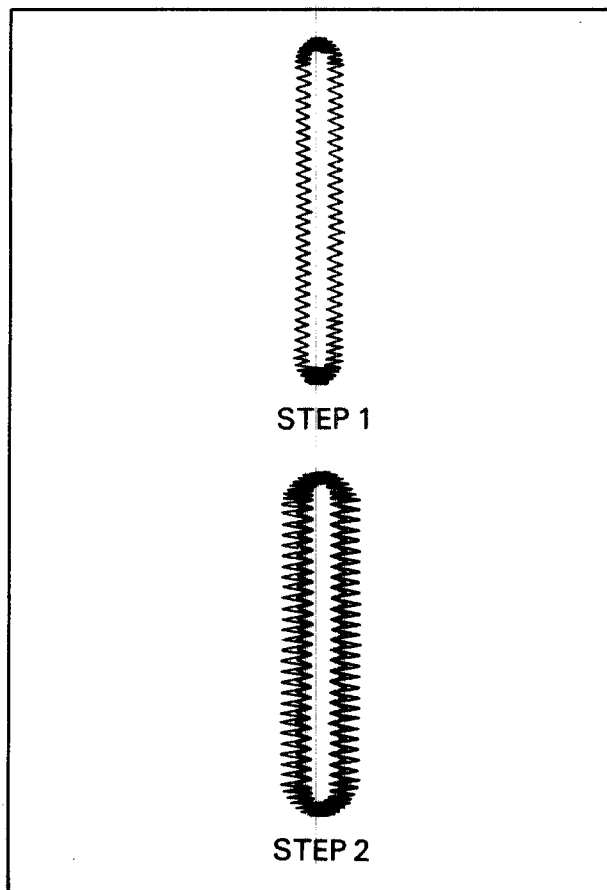

## PURL-EDGE BUTTONHOLE

To add a professional touch to your sewing you will want to make purl-edged buttonholes. These are obtained by sewing a wide buttonhole over a narrow stitched buttonhole.

Choose the correct size for your button, insert the template into the guide plate turning to the **narrower** of the sizes. Use the same settings as for regular buttonhole and adjust **stitch width control to 1**.

Drop the guide plate over the pinion gear and sew around the buttonhole once. (STEP 1)

To sew wider outer buttonhole, lift the guide plate from the pinion gear and turn the template to **wider** size. Adjust **stitch width setting to 1.5**, and sew around buttonhole again. (STEP 2)

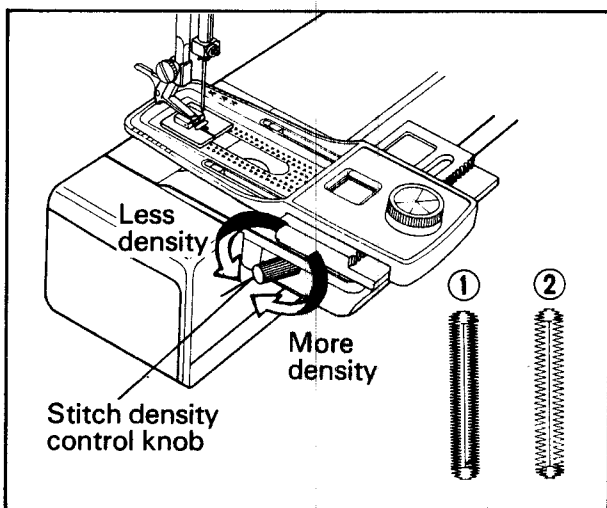

## ADJUSTING STITCH DENSITY

Depending upon the fabrics on which you are sewing, or your own preference in buttonholes, you may alter buttonhole stitch density by turning stitch density control knob.

1. For more density, turn the knob toward you.
2. For less density, turn the knob away from you.

## BOUND BUTTONHOLE

A template has been provided so that you may sew perfectly sized rectangles each time you make a bound buttonhole. Just follow the directions given below.

### SETTING

Stitch Width - 0 or Stitch Selector - - - - -

Pressure Regulator - 1 or 2

Other settings same as regular worked buttonhole

1. Space buttonholes on garment-mark length on right side of fabric with pins. Place patch of fabric over each buttonhole and mark ends of buttonhole with chalk or pencil. Baste patch into place. Using template similar in size to buttonhole, stitch rectangle on patch and garment. Do not sew over pins. (Fig. 1)
2. Slash through patch and garment to within 1/4" of ends of rectangle. Carefully cut diagonally into corners as shown. (Fig. 2)
3. Turn patch to wrong side through slash. Press as shown. (Fig. 3, 4)

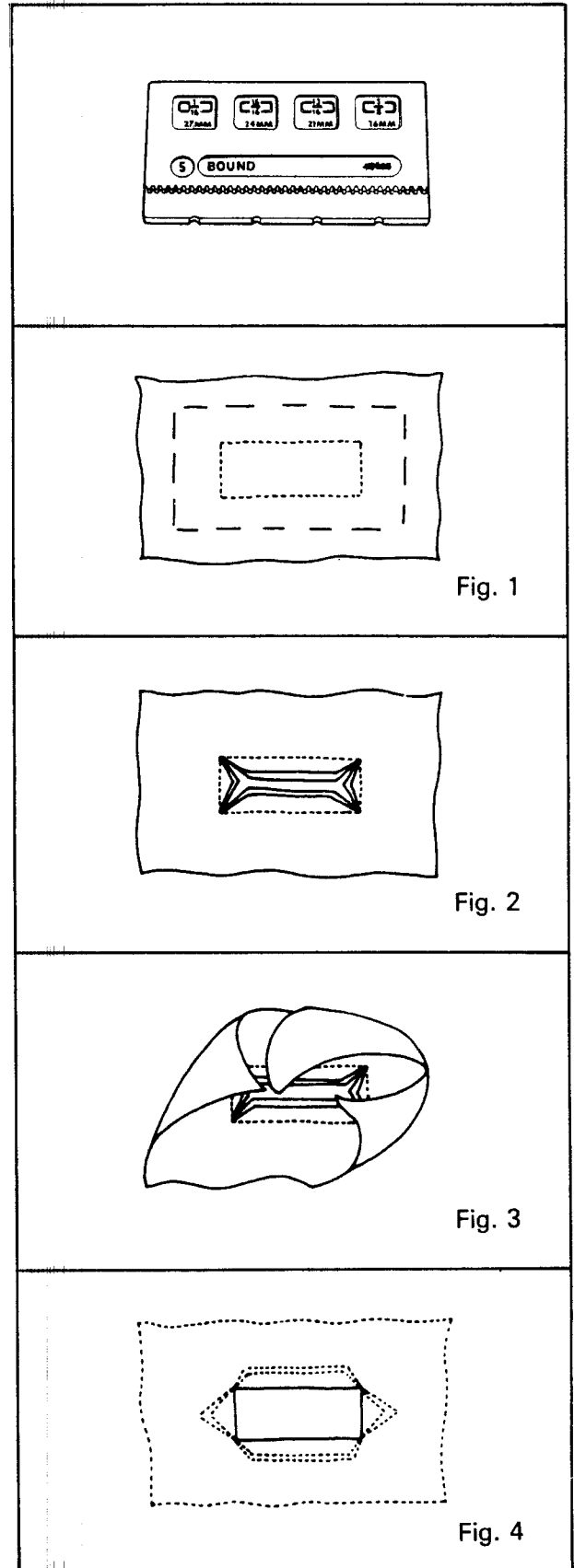

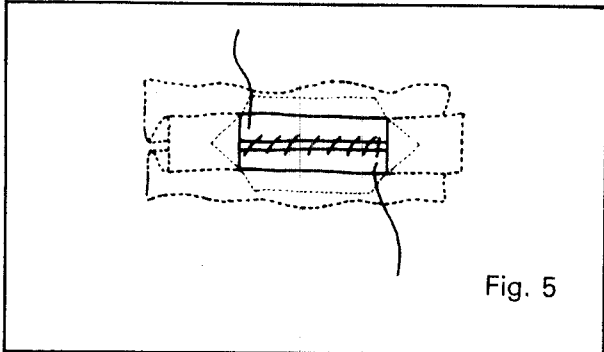

Fig. 5

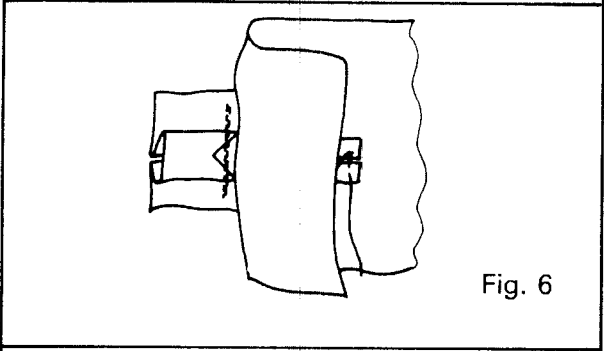
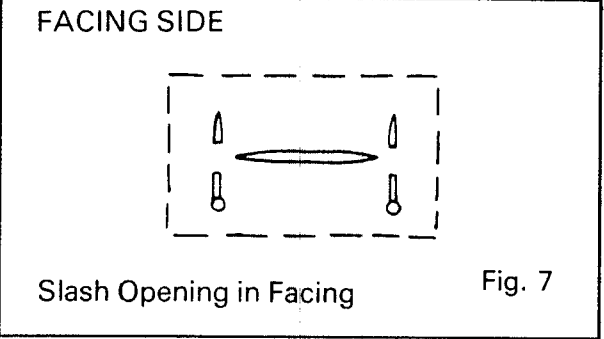
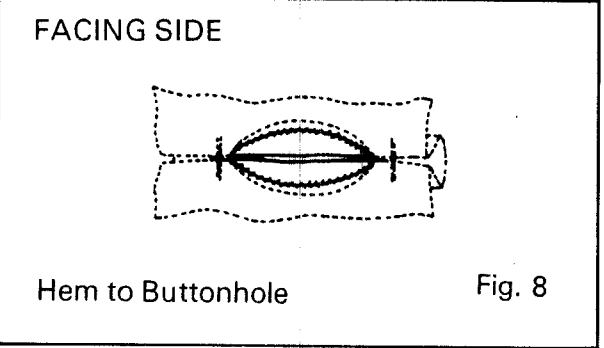

Fig. 6



Slash Opening in Facing

Fig. 7



Hem to Buttonhole

Fig. 8

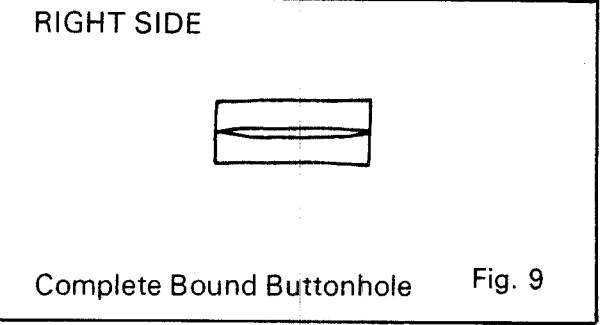

Complete Bound Buttonhole

Fig. 9

4. Fold patch forming lips of buttonhole. Press and baste lips together. (Fig. 5)

5. Stitch across pleats formed by lips of patch. (Fig. 6)

6. After buttonhole has been pressed, baste facing of garment around buttonhole and slash opening in facing same length as buttonhole. (Mark ends of buttonhole with pins for guides). Turn under facing edges and hem to buttonhole carefully. (Fig. 7, 8)

7. Remove all bastings and press. (Fig. 9)

## DECORATIVE EMBROIDERY DESIGNS

You may get the look and feel of hand embroidery infinitely faster and easier by your machine.

Just choose which of the designs you want to sew alone or in combination with each other.

### TIPS ON DESIGN STITCHING

1. Always make a practice design on a scrap of the fabric you plan to use.
2. Start with a full bobbin and plenty of thread on the spool to avoid running out of thread in the middle of your design.
3. Reduce the top thread tension slightly.
4. On a very soft fabric you may want to use a tissue paper backing or organdy that can be cut away.
5. Decorative designs are very attractive sewn with a double needle and two colors or shades of a color of thread.

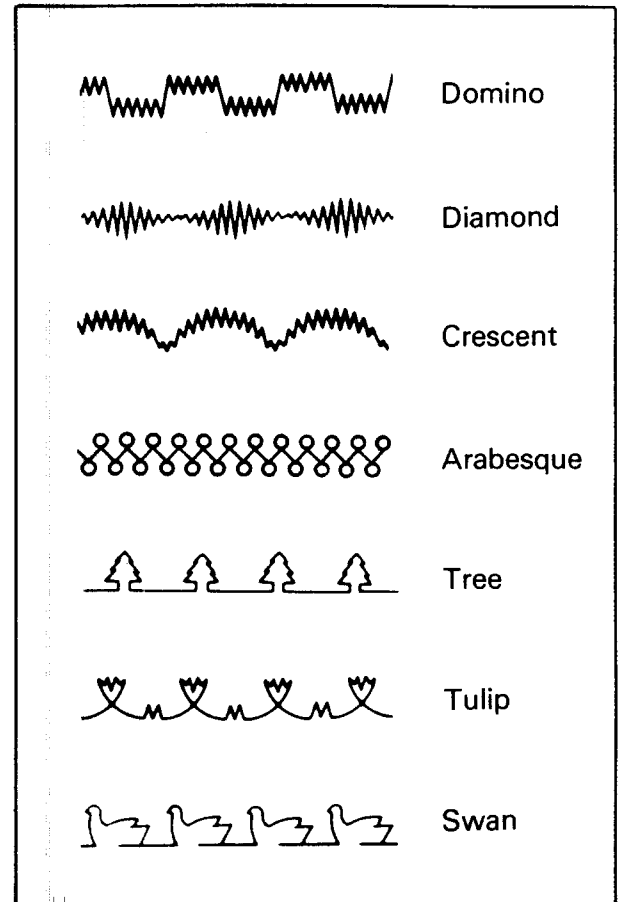

### ADJUSTING STITCH BALANCE OF YELLOW PATTERNS

When sewing yellow patterns, you may need to make slight adjustment to the stitch modifier to produce perfect designs.

If the stitches are too far apart, turn the control slightly clockwise; if they are closer together, turn counter-clockwise.

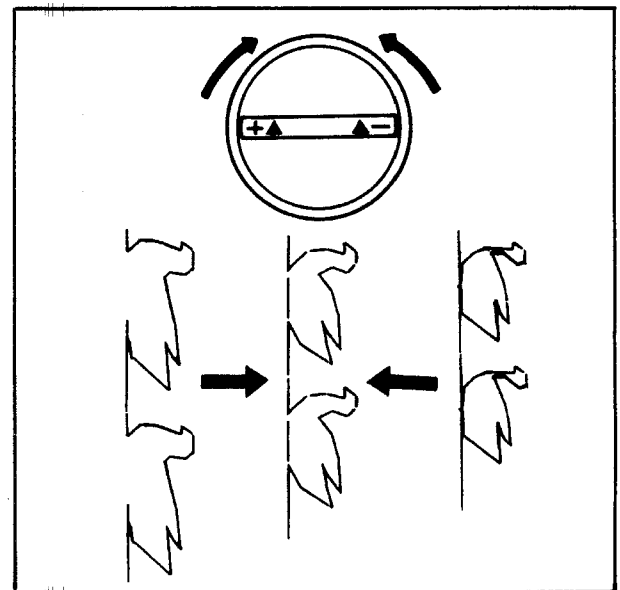

## **SEWING MACHINE**

Now that you have purchased your Sewing Machine, should a need ever exist for repair parts or service, simply contact any Sears Service Center and most Sears, Roebuck and Co. or Simpsons-Sears Limited Stores. Be sure to provide all pertinent facts when you call or visit.

The model number of your Sewing Machine will be shown on your nomenclature plate on the front side of bedplate of your Sewing Machine. See Section 1, Page 2 for location.

**WHEN ORDERING REPAIR PARTS, ALWAYS GIVE THE FOLLOWING INFORMATION:**

**\*MODEL NUMBER \*NAME OF ITEM \*PART DESCRIPTION**

If the parts you need are not stocked locally, your order will be electronically transmitted to a Sears Repair Parts Distribution Center for handling.

**SEARS, ROEBUCK AND CO., Chicago, IL 60684 U.S.A.**