



Quality Refrigeration

OWNER'S MANUAL



TBC Series Blast Chillers

- TBC5 (5-pan level undercounter model)
- TBC13 (13-pan level reach-in model)
- TBC1H (1-rack capacity roll-in model)
- TBC1HR (1-rack capacity roll-thru model)

**For equipment produced after January 2026 only.*

***Contact your local Traulsen sales representative to arrange for a free on-site demonstration
(after warranty registration and/or installation validation)***

***Traulsen's blast chillers are solely intended for blast chilling, and not for use as holding cabinets.**

4401 Blue Mound Road Fort Worth, Texas 76106 (USA)
Phone: 800.825.8220 | Service Fax: 817.740.6757 | E-mail: service@traulsen.com | Website: traulsen.com

Hours Of Operation: Monday - Friday 7:30 a.m. - 4:30 p.m. (CST)



I. Table of Contents

II. Introduction

a-Overview	Page 2
b-Basic Operation	Page 2
c-Defrost	Page 2
d-Installation Checklist	Page 2

III. Receipt Inspection

Page 3

IV. Installation

a-Location	Page 3
b-Packaging	Page 3
c-Wiring Diagram	Page 3
d-Installing Legs or Casters	Page 3
e-Interior Arrangements	Page 4
f-Electrical Requirements/Cord & Plug	Page 4
g-Proper Clearances	Page 4
h-Condensate Removal	Page 4
i-Remote Condensing Unit Requirements	Page 4
j-Sealing Roll-In/Roll-Thru Units	Page 5
k-ON/OFF Power Switch	Page 5
l-Capacity	Page 5

V. Care & Maintenance

a-Cleaning The Condenser	Page 5
b-Cleaning the Exterior	Page 5
e-Cleaning The Interior	Page 5

VI. Other

a-TBC1H/TBC1HR Service Check & Start-Up	Page 5
c-On-Site Blast Chill Training	Page 5
d-Demonstrations	Page 5

VII. Basic Operating Guidelines

a-Chilling Within HACCP Guidelines	Page 6
b-Loading	Page 6
c-Use of Food Probes	Page 6
d-Covering Product	Page 6
e-Multi-Batching	Page 6
f-USB Port	Page 7
g-Time Zones	Page 7
h-Usernames	Page 7

VIII. The Control

a-The Control-Overview	Page 8
b-Modes of Operation	Page 8
c-Operating Cycles	Page 8
d-Programs	Page 8
e-Auto Start Program Gallery	Page 9
f-Quick Start Program Gallery	Page 9
g-Create Program	Page 10

IX. Operation

a-Auto Start	Page 10
b-Quick Start	Page 11
c-Manual Operation	Page 11
d-Multi Operation	Page 13
e-Adding Product to a Cycle in Progress	Page 15
f-Cold Holding	Page 15
g-Freezing Product	Page 15
h-Defrosting	Page 15
i-HACCP	Page 16
j-Temperature Cycle	Page 16
k-Time Cycle	Page 17
l-Exported Data	Page 17
m-Users	Page 17
n-Products	Page 18
o-Settings	Page 18
p-General Management	Page 19
q-Display	Page 19
r-Printers	Page 19
s-Supervisor Settings	Page 20
t-Chilling & Installation Choices	Page 20
u-Libraries & Data	Page 20

X. Service/Warranty Information

Page 21

XI. Troubleshooting









Page 22

XII. TBC13 Condensate Kit Install Instructions

Page 23

THE SERIAL TAG:

The serial tag is a permanently affixed sticker on which is recorded vital electrical and refrigeration data about your Traulsen product, as well as the model and serial number. This tag is located inside the door on the right interior wall of the cabinet.

				ITW Food Equipment Group, LLC North American Refrigeration 4401 Blue Mound Rd. Ft. Worth, TX 76106 800-825-8220			
MODEL:	TBC5						
MODELO:							
MODELE:							
SERIAL NUMBER:				SCAN FOR SERVICE INFO			
REFRIGERANT / REFRIGÉRANT / RÉFRIGÉRANT							
SYS1 (REFM):	R-290	5.30 OZ	150.23 g	150.23 g			
Hi Press. (PRESH):		450.00 psi	3,102.64 kPa	3,102.64 kPa			
Lo Press. (PRESL):		200.00 psi	1,378.95 kPa	1,378.95 kPa			
SYS2 (REFA):	NA						
Hi Press. (PRESH):							
Lo Press. (PRESL):							
Input Power (ELIN) - FOR INDOOR USE ONLY							
Voltage	Hertz	Phase	Total Amps				
115	60	1	16.00				
Device/Part Number:	Device/Part Notes:						
TBC5-6B							
							
							
							
COMPONENTS / COMPOSANTS / COMPONENTES							
	1	2	MAX OVER CURRENT PROTECTION (A):				
COMP AMPS:			MIN CIRCUIT IN AMPS:				
COND FAN AMPS:			DOME LIGHT WATTS:				
EVAP FAN AMPS:			DISPLAY LIGHT WATTS:				
CONTROL AMPS:			DOOR HEATER WATTS:				
DEF HEATER WATTS:			B/TMCE HTR WATTS:				
370-60297-00 REV. D 01/15/2024							

READING THE SERIAL TAG

- Serial = The permanent ID# of your Traulsen
- Model = The model # of your Traulsen
- Volts = Voltage
- Hz = Cycle
- PH = Phase
- Total Current = Maximum amp draw
- Minimum Circuit = Minimum circuit ampacity
- Lights = Light wattage
- Heaters
- Refrigerant = Refrigerant type used
- Design Pressure = High & low side operating pressures and refrigerant charge
- Agency Labels = Designates agency listings

II. Introduction

II. a - OVERVIEW:

It is important to note that although this product is designed to chill hot product from 135°F down to below 41°F within FDA/HACCP guidelines, several operational factors, such as product temperature, density, loading, etc. will effect actual chilling performance. As a result, although easy to use, the operation of blast chilling requires diligent attention on the part of the operator(s) in order to facilitate proper results.

It is also important to note that many perceived service problems can actually be attributed to operational issues, resulting in lost product and/or down time. Please review the instructions contained within this manual completely, and make certain that all operators are well trained in the equipment's proper use.

II. b - BASIC OPERATION:

All Traulsen blast chillers accomplish their task by rapidly circulating very cold air. Upon starting a chill cycle using the STANDARD method, interior cabinet air temperature is set to a -27°F differential from the target temperature. When using the default target of 37°F the chiller will cycle between 10°F (OFF) and 15°F (ON). These temps were determined as optimum for rapid chilling product without freezing.

NOTE: For products prone to freezing (ex. high water content such as produce) we recommend use of the DELICATE method. Delicate uses a differential of only -7°F from the target temperature.

The blast chiller will continue this operation until such time as all probes reach the target temperature (when chilling by TEMP) or all time zones have elapsed (when chilling by TIME). At this point it will automatically return to MAINTENANCE operation with cabinet air temperature maintained at the target temperature (default 37°F). This maintains chilled food safely refrigerated and in the case of FREEZE cycles, the product will be held at the correct frozen temperature.

II. c - DEFROST:

All refrigeration equipment require a regular defrost cycle in order to maintain their evaporator coils clear of ice. The Traulsen blast chillers covered in this manual are programmed to automatically defrost every (4) four hours.

The period of defrost will be a maximum of 30 minutes in duration (DefrostMaxTime + DefrostWaitTime + RecoveryMax). This is temperature terminated. Should the coils reach their target temperature of 50°F prior to that time elapsing, the blast chiller will automatically stop defrosting and return to normal operation.

Product left inside will be safely held because:

a) If occurring at the end of a chill cycle the cabinet air temp of 10-15°F will hold the product safely for the maximum 30 minutes of defrost.

b) If occurring while in maintenance mode the defrost period will almost certainly be significantly less than 30 minutes, so product temperature will not be effected.

NOTE: Do not open the door during defrost unless removing all product inside.

II. d - INSTALLATION CHECKLIST:

Install requirements vary by model...

Model TBC5

- 1) Insure proper clearances, no obstruction to either front louver for at least 24" from cabinet face.
- 2) Install all four standard legs or optional casters, insuring that the unit is level for proper operation.
- 3) Plug the power cord into a dedicated 115 volt, 20-amp NEMA 5-20R outlet.

Model TBC13

- 1) Insure proper clearances. No obstruction of the front louvers, 5-1/2" on the left, right and rear, and 12" above.
- 2) Install the legs or casters, insuring that the unit is level for proper operation.
- 3) Place condensate tube in to floor drain or install optional condensate evaporator.
- 4) Plug the power cord into a dedicated 208-230/60/1 volt, 20-amp NEMA 6-20R outlet.

Models TBC1H & TBC1HR

- 1) Insure proper clearances. No obstruction to either front louver, and for at least 12" above the cabinet. Unit must be located on a level surface.
- 2) Seal the unit to the floor in accordance with local sanitation codes.
- 3) Install the door ramp(s).
- 4) Place condensate tube into floor drain or install optional condensate evaporator.
- 5) Plug the power cord into a dedicated 115 volt, 20-amp NEMA 5-20R outlet.

IMPORTANT NOTES/WARNINGS

NOTE: In order to accomplish blast chilling, models TBC1H and TBC1HR require one properly sized remote condensing unit. This can be purchased from Traulsen or elsewhere, however installation would be by others.

NOTE: This appliance is not intended for use by people (including children) with reduced physical, sensory or mental capabilities, or lack of experience and knowledge, unless they have been given supervision or instruction concerning use of the appliance by a person responsible for their safety.

NOTE: Children should be supervised to ensure that they do not play with the appliance.

NOTE: The refrigerants for the partial units (for remote systems) must comply with A1 classification requirements.

NOTE: The unit uses "VORACOR™ CR 1193 Polyol and VORACOR CE 108 Isocyanate is a two-component polyurethane foam system expanded with HFO physical blowing agent 1233zd. This product is designed for use in commercial refrigeration applications and is non-flammable.

NOTE: Appliance component parts requiring replacement should only be replaced with like components so as to minimize the risk of possible ignition due to incompatibility.

II. Introduction (continued)

NOTE: The appliance is to be installed in accordance with the Safety Standard for Refrigeration Systems, ANSI/ASHRAE 15.

NOTE: The appliance is intended for use at altitudes below 2000 m.

NOTE: Blast Chillers are classified for operation at climate class 5.

Climate Class 5 refrigeration equipment is suitable for harsher conditions and includes equipment that can efficiently handle temperatures up to +40°C (104°F) and humidity up to 40% RH. These refrigeration units are ideal for use in commercial kitchens, warehouses, distribution centers, and specialty food retailers where maintaining consistent temperature is crucial. They are equipped with high-performance compressors and strong insulation to ensure optimal cooling performance in high-temperature environments.

WARNING: For partial units, do not exceed low side design pressure specified on the data plate.

WARNING: Do not store explosive substances such as aerosol cans with a flammable propellant in this appliance.

WARNING: Do not use electrical appliances inside the food storage compartments.

DANGER: Risk of fire or explosion. To be repaired only by trained service personnel. Do not puncture refrigerant tubing. Consult repair manual/owner's guide before attempting to service this product. All safety precautions must be followed. Dispose of properly in accordance with federal or local regulations.

III. Receipt Inspection

All Traulsen products are factory tested for performance and are free from defects when shipped. The utmost care has been taken in crating this product to protect against damage in transit. All interior fittings have been carefully secured and the legs or casters are boxed and strapped inside to prevent damage. Door keys will be attached to the handle with a nylon strip. The handle is protected by an easily removable nylon netting.

You should carefully inspect your Traulsen unit for damage during delivery. If damage is detected, you should save all the crating materials and make note on the carrier's Bill Of Lading describing the damage. A freight claim should be filed immediately. If damage is subsequently noted during or immediately after installation, contact the respective carrier and file a freight claim. There is a five (5) day limit to file freight damage with the carrier. Under no condition may a damaged unit be returned to Traulsen without first obtaining written permission (return authorization). You may contact Hobart/Traulsen customer care at 800-333-7447 to request a return.

Systems Using Refrigerant R-290 (Propane)

Traulsen has selected propane as the refrigerant for many of their products. In addition to its low global warming potential and impact on the environment, propane is an ideal refrigerant. It is a flammable refrigerant, however, which is why you will see a "flammable refrigerant" sticker on applicable products. Traulsen products using propane as the refrigerant are ETL approved and are safe to use in accordance with this Owner's Manual and general industry practices for commercial cooking environments. Please check with local codes or regulations for any restrictions to products using hydrocarbon refrigerants.

IV. Installation

IV. a - LOCATION:

Select a proper location for your Traulsen unit, away from extreme heat or cold. Allow enough clearance between the unit and the side wall so that the door(s) may open a minimum of 90°.

NOTE: The appliance shall not be installed in public corridors or lobbies.

IV. b - PACKAGING:

All Traulsen units are shipped from the factory bolted to a sturdy wooden pallet and durably packaged. Care should be taken when removing the packaging in order to avoid scratching the unit's exterior metal finish.

To remove the wooden pallet, first if at all possible, we suggest that the cabinet remain bolted to the pallet during all transportation to the point of final installation. The bolts can then be removed with a 3/4" socket wrench.

NOTE: DO NOT LAY THE UNIT ON ITS SIDE DURING TRANSPORTATION OR INSTALLATION.

IV. c - WIRING DIAGRAM:

Refer to the wiring diagram located on the rear of the cabinet for any service work performed on the unit. Should you require a wiring diagram, please contact Traulsen Service at (800) 825-8220, and provide the model and serial number of the unit involved.

IV. d - INSTALLING LEGS OR CASTERS:

▲ WARNING The cabinet must be blocked and stable before installing legs or casters.

6" high stainless steel legs are supplied standard for models TBC5 and TBC13. Casters in lieu of legs are available as an optional accessory for the same models. These are shipped from the factory packed inside a cardboard box which is strapped to one of the shelves. Remove the nylon strap and open the box, it should contain either four (4) legs or casters (and four bolts for each caster).

To install the legs or casters, first raise and block the unit a minimum of 7" from the floor.

For model TBC5 slide the legs or casters into the two channels under the front and back of the cabinet (see fig. 1). Secure in place by tightening the two bolts located at the base of each leg or caster.

IV. Installation (continued)

NOTE: Legs or casters must be installed towards the four corners of the unit for proper support.

On model TBC13 thread the legs into the threaded holes on the bottom of the cabinet (see fig. 2). Be certain that all legs are tightened securely. When the unit is set in its final position, it is important for proper operation that the unit be level. The legs are adjustable for this purpose, turn the bottom of the leg counter-clockwise to raise it, clockwise to lower it. Level the unit from front to back as well as side to side in this manner, using a level placed in the bottom of the cabinet.

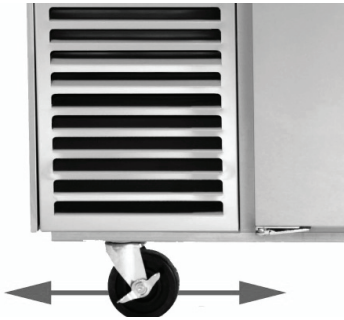

Fig. 1

For installing optional casters, these are “plate” type, and require the use of four (4) bolts to secure them firmly to the cabinet bottom at each corner (see fig. 3). The caster bolts are tightened using a 1/2” socket wrench.

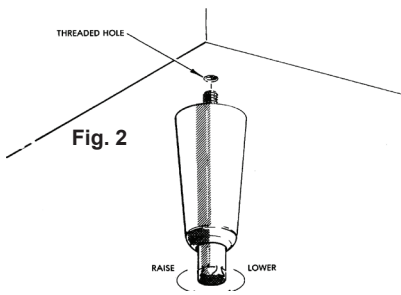

Fig. 2

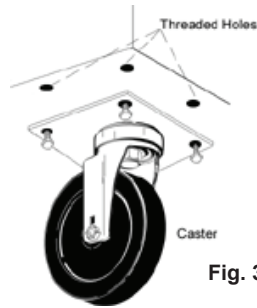

Fig. 3

IV. e - INTERIOR ARRANGEMENTS:

Models TBC5 and TBC13 are shipped with their full complement of trayslides already installed from the factory. Upon delivery the plastic ties used to secure these during shipping should be removed prior to first use.

The slides are spaced to allow for maximum capacity of 2” deep pans. If use of deeper pans is required, the slides can be removed and adjusted to accommodate this. However please note that the total quantity of pans possible will be reduced in order to make room for the deeper pans.

Model TBC1H and TBC1HR are designed to accommodate one roll-in rack with overall dimension (wheels inboard of frame) which do not exceed 72” high by 27” wide by 29” deep.

IV. f - ELECTRICAL REQUIREMENTS/CORD & PLUG:

Traulsen models TBC5, TBC13, TBC1H, and TBC1HR are supplied with a cord & plug attached. A remote condensing unit (supplied by others) will require a separate electrical connection of its own.

For your safety and protection, all units supplied with a cord and plug include a special three-prong grounding plug on the service cord. Select only a certified electrical outlet with grounding plug for power source. For TBC1H/R, cabinet is cord-connected and there is no electrical connection or control wiring between from cabinet to the remote condensing unit.

NOTE: Do not under any circumstances, cut or remove the round grounding prong from the plug, or use an extension cord.

A dedicated, grounded circuit should be provided to assure that the computerized control is not adversely affected by the operation of other equipment.

Models TBC5, TBC1H, and TBC1HR are provided with a NEMA 5-20P cordset.

Model TBC13 is provided with a NEMA 6-20P cordset.

IV. g - PROPER CLEARANCES:

Model TBC5: Insure proper clearances. No obstruction to either front louver for at least 24” from cabinet face.

Model TBC13: Insure proper clearances. No obstruction of the front louvers, 5-1/2” on the left, right and rear, and 12” above. This will allow for sufficient air flow to the refrigeration system and maintenance access.

Models TBC1H and TBC1HR: Insure proper clearances. No obstruction to either front louver, and for at least 12” above the cabinet. Unit must be located on a level surface. This will allow for sufficient airflow to the refrigeration system and maintenance access.

IV. h - CONDENSATE REMOVAL:

All Traulsen Blast Chill models (except model TBC5) require the use of a floor drain or optional electric condensate evaporator.

Model TBC13 requires either a floor drain or the use of an optional bottom mounted electric condensate evaporator pan kit (TBCACC-BMCE) for condensate removal. The drain port location is at the bottom right of the unit. A receptacle is provided underneath. See the back cover of this manual for installation instructions.

Models TBC1H and TBC1HR require either a floor drain or the use of an optional electric condensate evaporator pan kit (BCACC-60018) for condensate removal. This can be installed on the chiller through the access panel located front right at the bottom.

IV. i - REMOTE CONDENSING UNIT REQUIREMENTS:

For TBC1H and TBC1HR: Remote condensing unit(s) capacity requirement: 18,700 BTU/hr @ 0°f evaporator temperature (supplied by others).

IV. Installation (continued)

IV. j - SEALING ROLL-IN/ROLL-THRU UNITS:

This section applies only to models TBC1H and TBC1HR. Roll-In and Roll-Thru cabinets set on the floor require the floor area to be flat and level. In addition, after the cabinet is set in place, sealant should be used around the perimeter of the base to comply with NSF International requirements. After sealing the unit, the enclosed ramp should then be installed.

IV. k - ON/OFF POWER SWITCH:

The Traulsen Blast Chiller models are all equipped with a power ON/OFF switch intended to cut power to the control as needed. In the event of routine maintenance and/or service is needed, be certain to disconnect the electrical power to the machine and follow lockout/tagout procedures.

This is located on top of models TBC1H, towards the rear on top. On model TBC5, this switch is located in the compressor compartment. On model TBC13 this is located on the bottom right behind the front louver assembly.

IV. l - CAPACITY:

Pan and approximate maximum product weight capacities for the individual blast chiller models is as follows:

	Pans		Product
	18" x 26"	12" x 20"	Weight
• TBC5	5	10	100
• TBC13	13	26	200
• TBC1H	1 Rack	1 Rack	300

Actual capacity (i.e. weight of product) that can be safely chilled within FDA guidelines varies greatly depending upon individual product density and pan loading.

V. Care & Maintenance

▲ WARNING Disconnect electrical power supply before cleaning any parts of the unit.

V. a - CLEANING THE CONDENSER:

The most important thing you can do to ensure a long, reliable service life for your Traulsen is to regularly clean the condenser coil. The self-contained condensing unit requires regularly scheduled cleaning to keep the finned condenser clean of lint and dust accumulation. Keeping the condenser clean allows the cabinet to operate more efficiently and use less energy.

To clean the self-contained condenser, first disconnect electrical power. To access the coil:

TBC5: Open the refrigeration compartment door on left.

TBC13: Remove the four (4) screws securing the front louver panel at bottom and remove the panel.

TBC1H/TBC1HR: Remove the two (2) bottom screws securing the louver assembly located on the top/front of the cabinet and lift the louvers.

Vacuum or brush any dirt, lint or dust from the finned condenser coil, the compressor and other cooling system parts. If significant dirt is clogging the condenser fins, use compressed air to blow this clear.

For care of the remote condensing unit(s) used for models TBC1H & TBC1HR, consult the manufacturer's product literature.

Remove any ignition source (arc, flame, heat) before cleaning the condenser coil. If the condenser coil is inadvertently damaged during cleaning to the point of causing a refrigerant leak, immediately ventilate the area and call for service.

V. b - CLEANING THE EXTERIOR:

Exterior stainless steel should be cleaned with warm water, mild soap and a soft cloth. Apply with a dampened cloth and wipe in the direction of the metal grain. Avoid the use of strong detergents and gritty, abrasive cleaners as they may tend to mar and scratch the surface.

NOTICE Do **NOT** use cleansers containing chlorine, this may promote corrosion of the stainless steel.

Care should also be taken to avoid splashing the unit with water, containing chlorinated cleansers, when mopping the floor around the unit. For stubborn odor spills, use baking soda and water (mixed to a 1 TBSP baking soda to 1 pint water ratio).

V. c - CLEANING THE INTERIOR:

For cleaning stainless steel interiors, the use of baking soda as described in section "V. b" is recommended. Use on breaker strips as well as door gaskets. All interior fittings are removable without tools to facilitate cleaning.

NOTICE Only TBC13 models have a cabinet drain plug. Do **NOT** spray the TBC13 interior with a hose to clean. Care should be taken to avoid splashing of water in the unit's interior.

Please make sure the drain plug is in place at all times except while cleaning. Ensure that the cabinet drain is routed to the nearest floor drain. If the floor drain is not available, use conventional methods to wipe the interior clean (do not use cabinet drain).

VI. Other

VI. a - TBC1H/TBC1HR SERVICE CHECK & START-UP:

After installation and start-up of models TBC1H or TBC1HR, please contact the Service Department at (800) 825-8220 to arrange for a "Mechanical Installation and Operation Inspection," which is required by Traulsen in order to validate the warranty. On-site inspection not required for models TBC5 and TBC13.

VI. b - ON-SITE BLAST CHILL TRAINING:

Traulsen offers the operator comprehensive one and two day, onsite training in the proper operation of your Blast Chiller. Contact your authorized Traulsen equipment dealer for pricing information.

VI. c - DEMONSTRATIONS:

Traulsen sales representatives perform in-service operational training for the end-user. Contact your local Traulsen Sales Representative (after completion of the service agency start-up, on required models) to arrange this.

VII. Basic Operating Guidelines

VII. a - CHILLING WITHIN HACCP GUIDELINES:

The current FDA Food Code allows much more time for safe chilling than 90-minutes. This actually requires two critical control points of:

- a) From 135°F to 70°F within two hours, then...
- b) From 70°F to below 41°F within four hours, for a total chill time from 135°F to below 41°F of no more than six hours.

Total chill time can exceed six-hours in duration and still be safe. This safety threshold does not include:

- a) Any time needed for product to chill from any start temp down to 135°F, or...
- b) Any time elapsed to chill to below 41°F.

VII. b - LOADING:

To achieve quickest chill times product should be loaded to a depth of no greater than 2".

Products should always be loaded into the shallowest pan possible.

Chilling of products of greater than 2" depth is often possible within FDA guidelines. However please note that actual chill times are a function of: Start Temperature, Product Density, Product Depth, and Total Load.

Chilling of products, such as whole cooked chickens or meat-loaf can be accomplished. However these should be positioned inside the chiller to allow the airflow to contact the greatest surface area of the product.

VII. c - USE OF FOOD PROBES:

For most accurate results food probes should be used. These need to be properly placed in the center of the thickest part of the product to insure an accurate temperature reading.

Some products are not suitable for use of food probes. These products...

- a) Should be chilled by **TIME**.
- b) The correct chill time should be established by the operator based upon actual product testing.
- c) The end cycle temperature should be verified manually with a clean, accurate thermometer as soon as the pre-established chill time elapses.

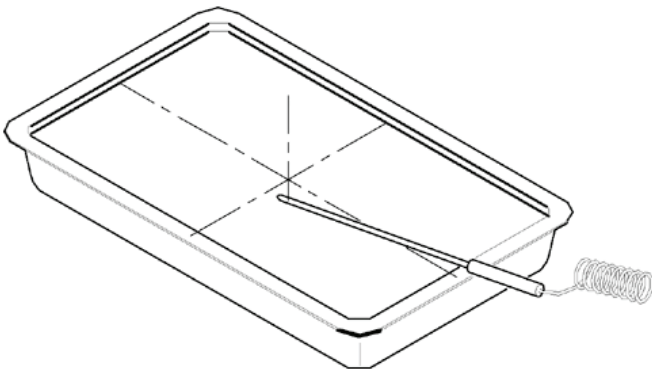

VII. d - COVERING PRODUCT:

Product does not always need to be covered. However before doing so please consider the following potential scenarios...

- a) If large loads of especially hot product are chilled there is the potential to freeze the coil.
- b) Loads of uncovered product that require especially long chilling times may have the potential to experience surface drying.
- c) Loads that are left uncovered in the chiller for long periods after completion of a chill cycle may also experience surface drying of the product if left uncovered.
- d) Loads of especially liquid product, such as soup, are highly recommended to be covered in order to prevent accidental spillage.
- e) Some foods, such as rice and pasta, are particularly vulnerable to drying and so should always be covered.

VII. e - MULTI-BATCHING:

Often an operator may wish to chill less than a full load of product, and/or to chill multiple types of products simultaneously, or at different intervals. This is known as "Multi-Batching."

In a multi-batching scenario it is critically important to manage the use of probes. For example if more than four different products need to be chilled, it is necessary to take the following into consideration:

- Like products should be grouped together in a single batch using one probe.
- Different products, or products started at different times should each have their own probe.
- If more than three products will ultimately be placed in the chiller at the same or different times, it will be necessary to: a) group like products together, or b) group unlike products together with the probe placed in the product which will take the longest to chill.

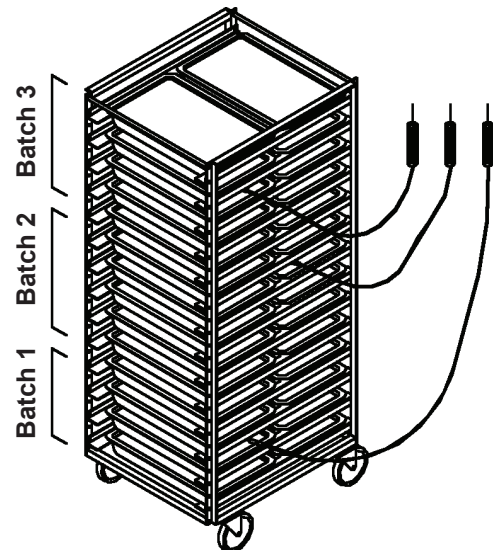

VII. Basic Operating Guidelines (cont'd)

VII. f - USB PORT:

A standard USB data port is provided. This allows the operator to download chill cycle data on to a thumb drive for easy transfer to a PC. It is also used to update the control's operating software.

VII. g - TIME ZONES:

When chilling without probes the control allows for operation by an operator determined time. In the **TIME** program there is one time zone provided which makes multi-batching possible. When using **Multi Mode**, up to ten time zones are provided.

Selecting a time zone permits entry of both a product and/or username, just as is done when using probes.

The zones are not specific to any location or number of pans in the chiller. The operator should determine how best to utilize these, for example Zone 1 = Top, Zone 2 = Middle, etc.

VII. h - USERNAMES:

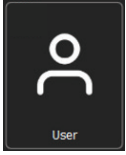

USER (i.e. operator) names can be programmed into the chiller memory using the **SETTINGS PAGE**. If a username is selected at the beginning of a chill cycle it will appear under the **USER** icon on the **RUN SCREEN**, as well as on any record for that chill cycle.

If no **USER** name is selected at the beginning of a chill cycle **NO USER** will appear under the **USER** icon on the **RUN SCREEN**, as well as on any record for that chill cycle.

At the end of the chill cycle a **USERNAME** may be entered prior to pressing **END**. Tap the **EDIT** icon in the HACCP report to edit the username.

VIII. The Control

VIII. a - THE CONTROL - OVERVIEW:

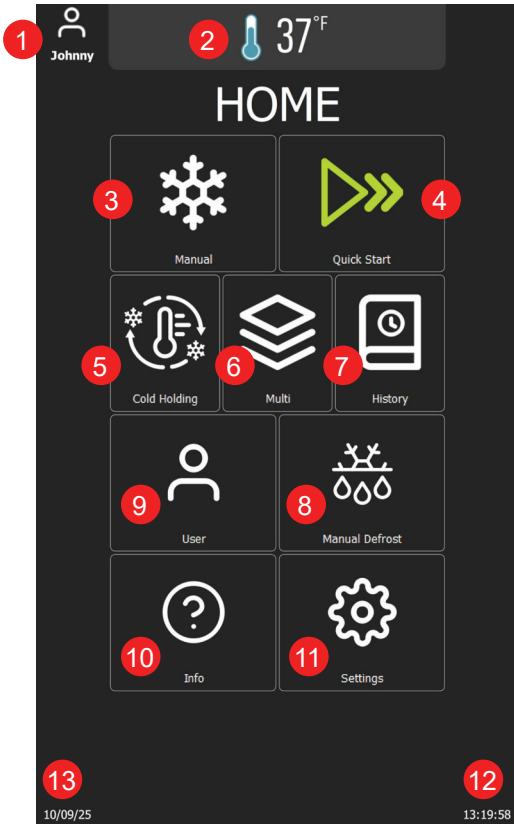

1. Current active user.
2. Cabinet temperature (indicates defrost when applicable)
3. **Manual Button:** Tap to navigate to the manual chilling/ freezing page
4. **Quick-Start Button:** Tap to initiate a time-based blast chilling cycle with one touch
5. **Cold Holding Button:** Tap to start a Cold Holding operation to maintain food at a specific temperature
6. **Multi Button:** Tap to begin a Multi operation for customized chilling needs
7. **History Button:** Tap to access the HACCP history page
8. **Defrosting Button:** Tap to start manual defrost operation
9. **User Button:** Tap to display and change the active user
10. **Info Button:** Access guides, key information
11. **Settings Button:** Tap to navigate to the settings page
12. Current date (MM:DD:YYY)
13. Current time (HH:MM:SS)

Traulsen blast chillers are equipped with our exclusive NextGen control. This has a durable, water resistant, touch screen interface for ease of use, and is surrounded by a heavy gauge metal frame to protect it from damage.

The NextGen control can be used in one of two distinct operating modes: **AUTO** or **MANUAL**.

VIII. b - MODES OF OPERATION:

The first mode of operation is **AUTO**. This is designed to start a chill cycle whenever one or more probes is placed into product above 90°F, ensuring proper operation.

MANUAL is a fully adjustable mode which allows the operator to select from a wide range of chill settings.

VIII. c - OPERATING CYCLES:

The control is capable of managing the following blast chilling cycles:



Standard temperature OR time-controlled blast chilling



Speed temperature OR time-controlled blast chilling



Delicate temperature OR time-controlled blast chilling



Temperature OR time-controlled blast freezing

In addition to blast chill cycles, the control is also capable of managing the following special cycles:



Programs with pre-defined cycles (how to chill)



Manual defrost



Multi operation: mixed operation with timers & core probes



Cold holding: extra storage with wide temperature setpoint range

NOTE: Blast freeze function is not available in TBC1H and TBC1HR models.

VIII. d - PROGRAMS:

Programs are pre-installed chill settings designed to simplify and optimize operation. These cater to various food types, portion sizes, and cooling requirements to support consistent and efficient performance.

- **Auto-Start:** Using the food probe to activate a cycle
- **Quick-Start:** Using a simple touch to activate a cycle
- **Manual:** Applying a program to a manual operation

To change the programs, navigate to **Settings>Supervisor>Enter Password (1234)>Chilling & Installation Choices**

VIII. The Control (continued)

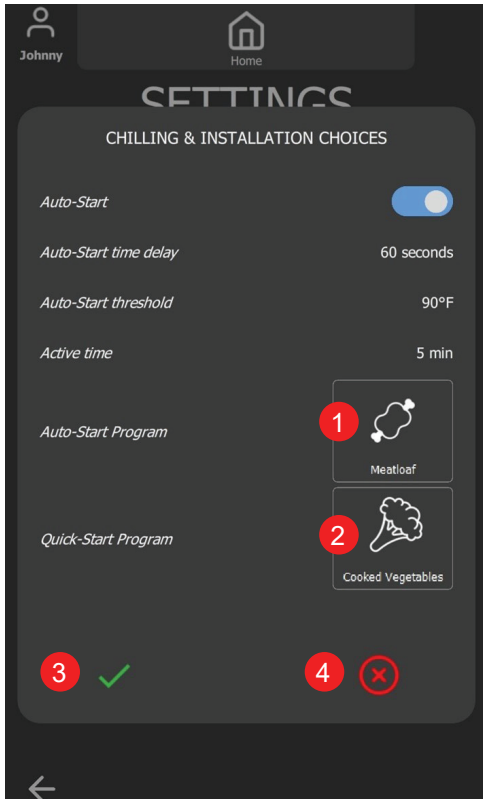

1. **Quick-Start Program Button:** Tap to display the Quick-Start Program's Gallery and change the Quick-Start Program
2. **Auto-Start Program Button:** Tap to display the Auto-Start Program's Gallery and change the Auto-Start Program
3. **Accept Button:** Tap to accept all changes and close
4. **Cancel Button:** Tap to discard all changes and close

VIII. e - AUTO START PROGRAM GALLERY:

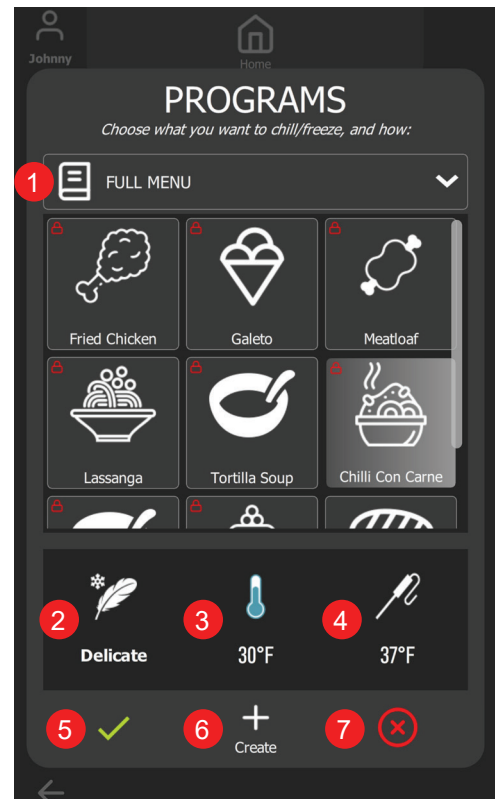
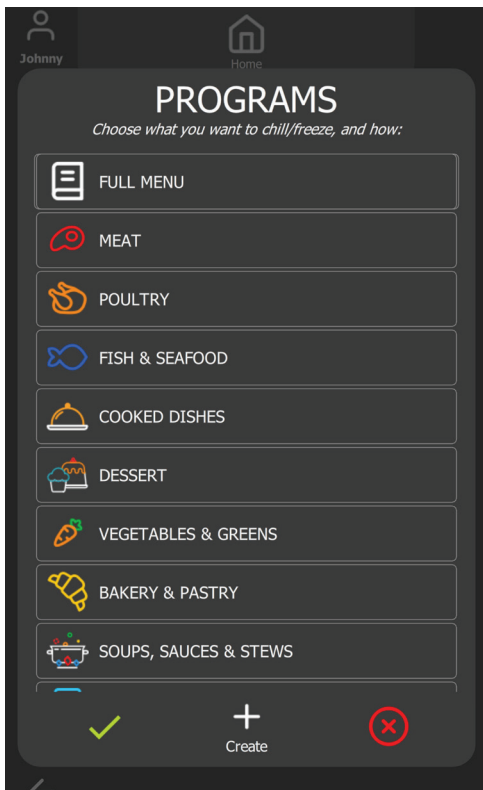

1. **Menu Button:** Tap to change the category
2. Selected Auto-Start mode (**Standard, Speed, or Delicate**)
3. Selected Auto-Start air temperature setpoint
4. Selected Auto-Start target temperature
5. **Accept Button:** Tap to accept all changes and close
6. **Create Button:** Tap to create a program
7. **Cancel Button:** Tap to discard all changes and close

VIII. f - QUICK START PROGRAM GALLERY:

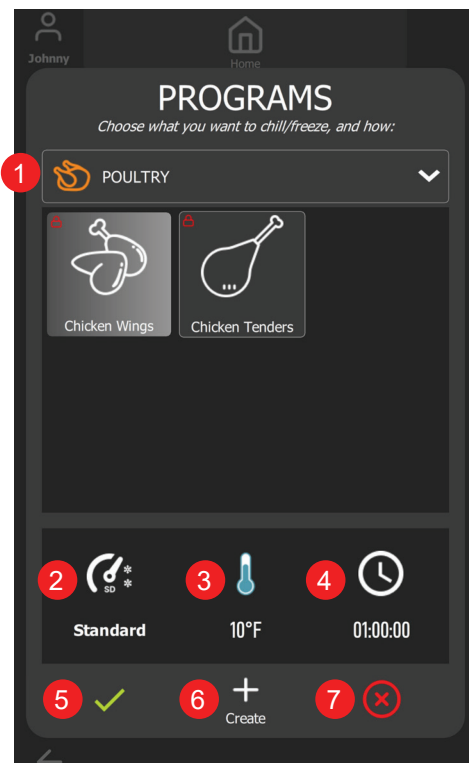

VIII. The Control (continued)

1. **Menu Button:** Tap to change the category
2. Selected Quick-Start mode
3. Selected Quick-Start air temperature setpoint
4. Selected Quick-Start cycle duration
5. **Accept Button:** Tap to accept all changes and close
6. **Create Button:** Tap to create a program
7. **Cancel Button:** Tap to discard all changes and close

VIII. g - CREATE PROGRAM:

Users can create their own chill program to fit their daily use. To create a chill program, simply press the **Create Button** on the programs gallery as shown in the figure above.

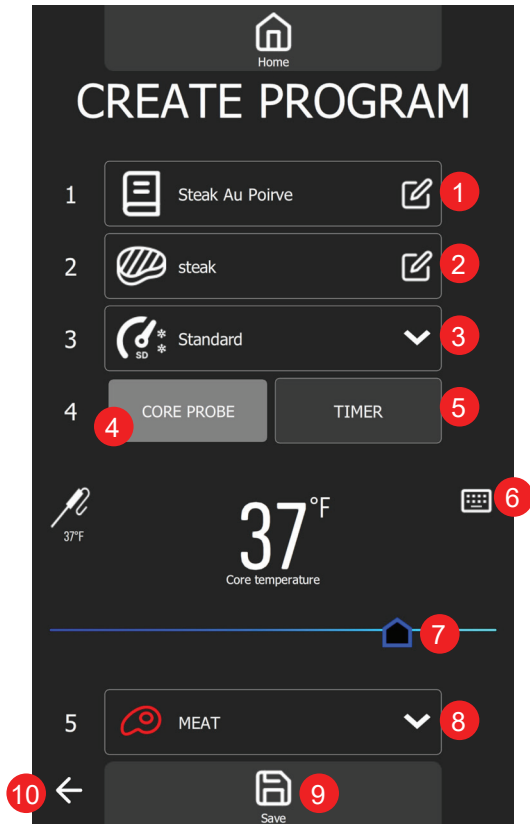

1. **Program Name Input:** Tap to enter the program name using the virtual keyboard
2. **Icon Select Button:** Tap to select an icon for the Program
3. **Chill Mode List:** Select chill mode for the Program
4. **Auto-Start Select Button:** Tap to select temperature Program
5. **Quick-Start Select Button:** Tap to select timer Program
6. **Keypad:** Tap to turn on the keypad and change the time temperature target value
7. **Slider:** Drag to adjust the core probe target temperature or chill duration
8. **Program Category:** Tap to change the Program category
9. **Save Button:** Tap to save the Program settings
10. **Return Button:** Tap to discard and return to the home page

Users can remove or edit the created programs (default programs cannot be removed or edited) directly by pressing and holding the program on the list.

IX. Operation

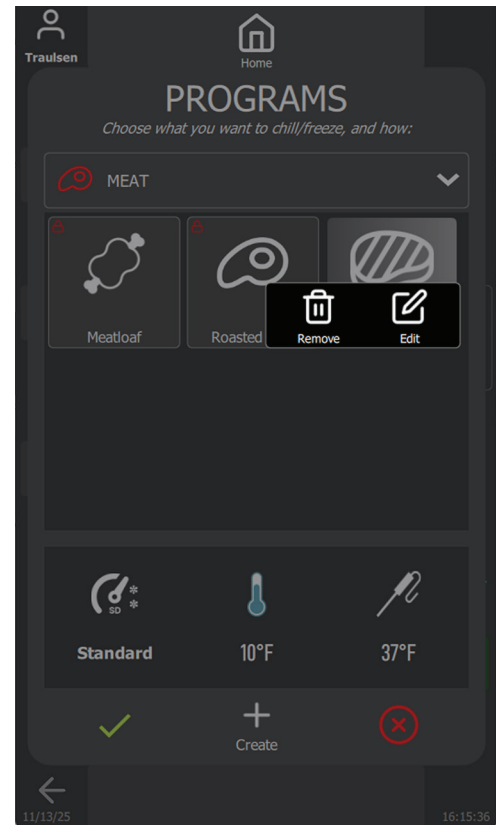

IX. a - AUTO START:

The default Auto Start Program is set to Standard function with a target temperature of 37°F, but it can be modified in the Programs menu. Auto Start is activated when the user is not using the user interface and after inserting core probe/probes into the hot food. When conditions are met, a dialog box will automatically pop up on the home page.



NOTE: Food must be above 90°F in order to **AUTO** start.

When adding probes to a chill cycle already in process simply place any available probe into hot product above 90°F and these will be automatically added. **NOTE:** The operator can edit the user and/or product name during chilling and/or at the cycle end.

Customizing Auto-Start:

Auto-Start's settings can be customized by accessing the **Settings Page>Supervisor>Chilling & Installation Choices**.

IX. Operation (continued)

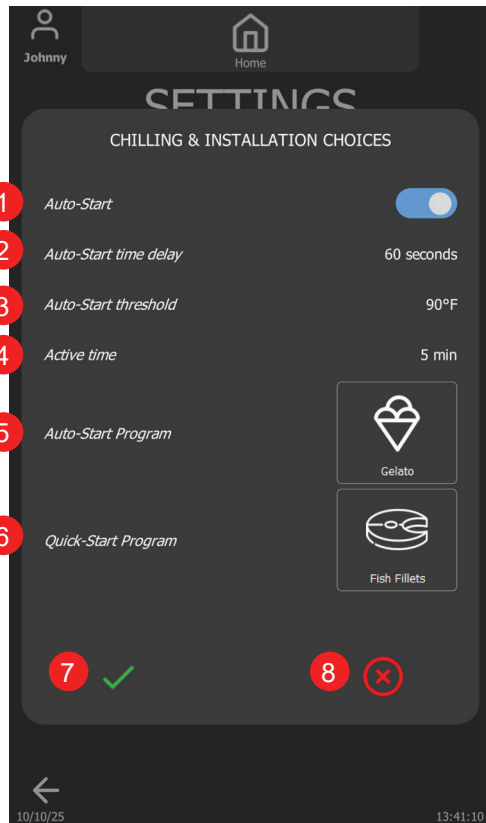

1. **Auto-Start Switch:** Enable or disable the feature
2. **Auto-Start Time Delay Button:** Tap to turn on the virtual keypad to change the countdown timer until the blast chill cycle starts automatically
3. **Auto-Start Threshold Button:** Tap to turn on the virtual keypad to change the temperature threshold to trigger auto-start countdown
4. **Active Time Button:** Tap to turn on the virtual keypad to change the time to switch back to Home Page and to trigger auto-start
5. **Auto-Start Program:** Tap to change the auto-start program
6. **Quick-Start Program:** Tap to change the quick-start program
7. **Accept Button:** Tap to save all changes and close
8. **Cancel Button:** Tap to discard all changes and close

Auto-Start Programs:

The NextGen Blast Chiller comes equipped with some default programs, illustrated below.

Name	Function	Target
	Standard	37°F
Fried Chicken	Standard	37°F
Gelato	Freeze	0°F
Meatloaf	Standard	37°F
Lasagna	Standard	34°F
Tortilla Soup	Standard	32°F
Chilli Con Carne	Delicate	37°F
Cream-Based Sauces & Soups	Delicate	37°F
Custards & Puddings	Delicate	37°F

IX. b - QUICK START:

Quick Start is a user-friendly feature that allows you to instantly

begin a time-controlled blast chill cycle with a single press on the home screen. Designed for convenience, it streamlines daily use by eliminating the need to navigate multiple options.

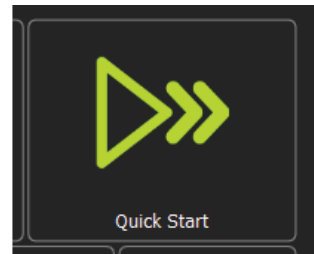

Quick Start Programs:

The NextGen Blast Chiller comes equipped with some default programs, illustrated below.

Name	Function	Target
	Standard	01:30:00
Chicken Wings	Standard	01:00:00
Sandwich	Delicate	00:10:00
Chicken Tenders	Standard	01:30:00
Roasted Beef	Speed	04:00:00
Cooked Shrimps	Delicate	01:00:00
Fish Fillets	Delicate	01:30:00
Chopped Vegetables	Delicate	00:20:00
Cooked Vegetables	Delicate	00:30:00

IX. c - MANUAL OPERATION:

MANUAL mode allows adjustments to be made to all chilling parameters, thus customizing the cycle to best suit the product and/or process. Navigate to the manual page by pressing the "Manual" button on the Home Page.

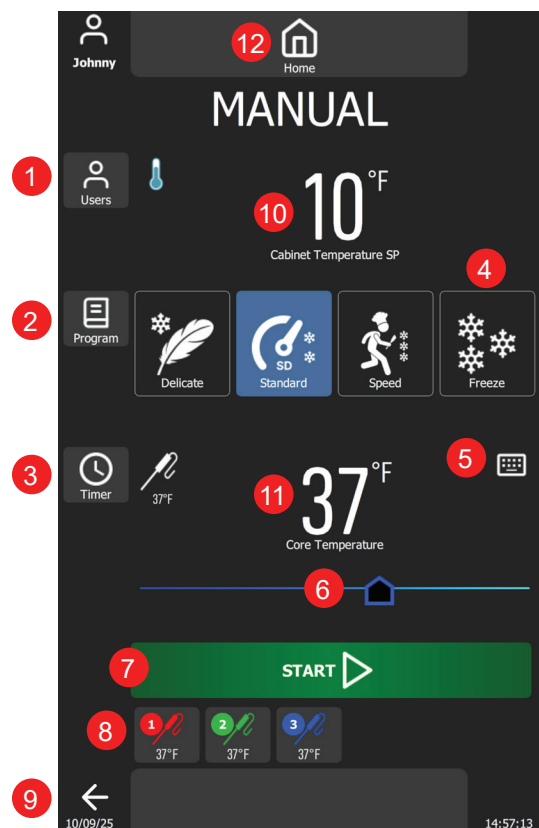

IX. Operation (continued)

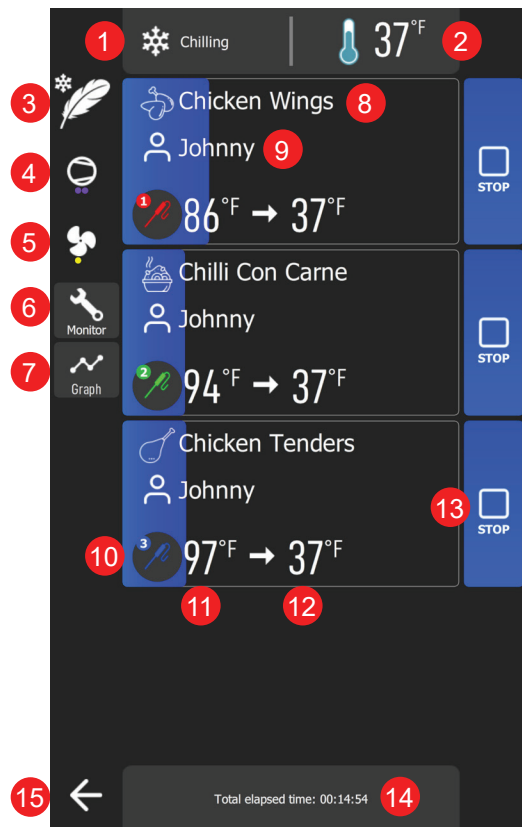
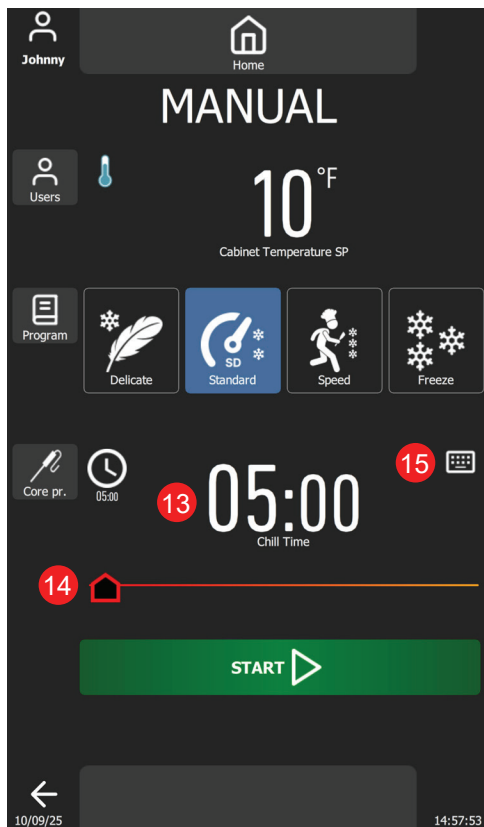

1. **User Button:** Tap to change the active username
2. **Program Button:** Tap to apply the program to the current manual cycle
3. **Timer/Core Probe Button:** Tap to switch between temperature-based or time-based cycle
4. **Mode List:** Manual Mode selection
5. **Keypad:** Tap to turn on the virtual keypad to change the target temperature setpoint (temp-based cycle)
6. **Slider:** Drag to change the target temperature setpoint (temp-controlled cycle)
7. **Start Button:** Tap to start the cycle
8. **Core Probes List:** Core probe selection list
9. **Return Button:** Tap to return to home page
10. Cabinet temperature setpoint display
11. Core probe target temperature setpoint display (temp-controlled cycle)
12. **Home Button:** Tap to return to home page
13. Total cycle time display (time-controlled cycle)
14. **Slider:** Drag to change the cycle time (time-controlled cycle)
15. **Keypad:** Tap to turn on the virtual keypad to change the operation time (time-controlled cycle)

After the temperature-based cycle has been initiated with the three food probes selected, the following page will appear.

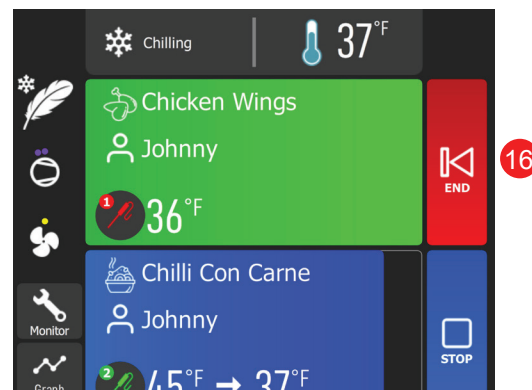

1. Control state status
2. Real-time cabinet temperature
3. Selected chill mode
4. Compressor status (each dot represents the number of compressors running)
5. Cabinet fan status (red means high speed and yellow means low speed)
6. **Monitor Button:** Tap to turn on real-time system monitor
7. **Graph Button:** Tap to turn on graph view
8. Product name, **tap** to change
9. User name, **tap** to change
10. Core probe number
11. Core probe temperature
12. Target temperature
13. **Control Button:** Tap to stop monitoring corresponding core probe
14. Total elapsed time

IX. Operation (continued)

15. **Return Button:** Tap to return to Home Page

16. **Control Button:** Tap to end the cycle and HACCP record will display

After the time-based cycle has been initiated with the selected duration, the following page will appear.

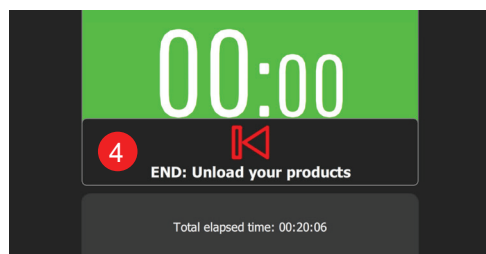
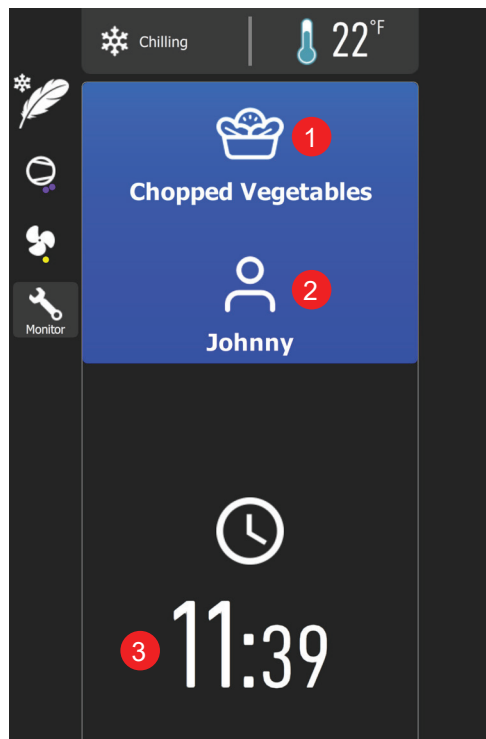

1. Product display, **tap** to change the product name
2. User display
3. The remaining blast chill time
4. **Control Button:** Tap to end the blast chill cycle

IX. d - MULTI OPERATION:

The multi-mode is designed to provide maximum flexibility for kitchens handling a variety of dishes simultaneously. This allows the user to chill multiple types of food with different sizes, textures, and cooling requirements all in one cycle.

Using timer and core probes, the system monitors and adjusts chilling parameters to ensure each product reaches its optimal temperature without compromising quality. This mode is ideal for a la carte service environment where individual portions need to be quickly and efficiently chilled to meet food safety standards while preserving taste, texture, and appearance.

Once each product meets the desired requirements, its HACCP information is automatically recorded in the history database.

Upon entering the Multi page, the cycle selection will be displayed. The user must select a cycle before starting the chilling process.



1. Cabinet temperature setpoint
2. **Speed Mode** maintains cabinet temperature between **0°F and 5°F**
3. **Standard Mode** maintains the cabinet temperature between **10°F and 15°F**
4. **Delicate Mode** maintains the cabinet temperature between **30°F and 35°F**
5. **Keypad:** Tap to modify the cycle duration
6. Cycle duration
7. **Slider:** Drag to modify the cycle duration
8. **Accept Button:** Tap to start chilling
9. **Cancel Button:** Tap to exit and return to Home Page

When users select Chill Mode and press the Accept button, the chill cycle begins, and the following page will be displayed.

IX. Operation (continued)

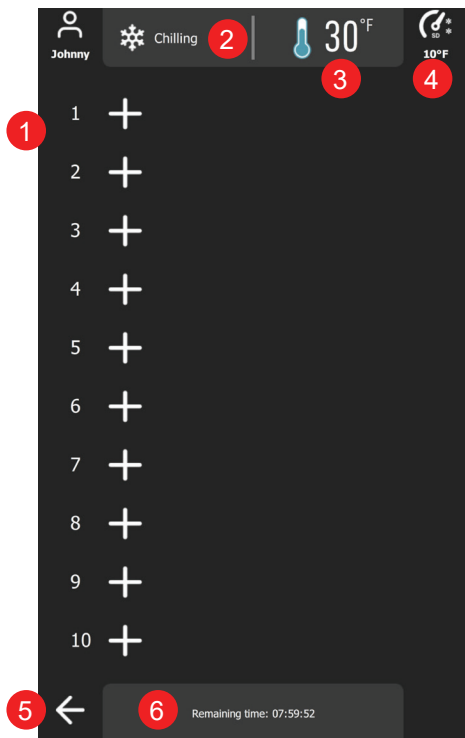

1. **Level Setup Buttons:** Tap to turn on the level setup dialog
2. Control state status
3. Cabinet temperature
4. Selected chill mode and cabinet temperature setpoint
5. **Cancel Button:** Tap to cancel the operation and return to Home Page
6. Total chill time

Users can select any level to start the timer or use the food probe to monitor the product by simply pressing the plus icon, then the tray setup will appear.

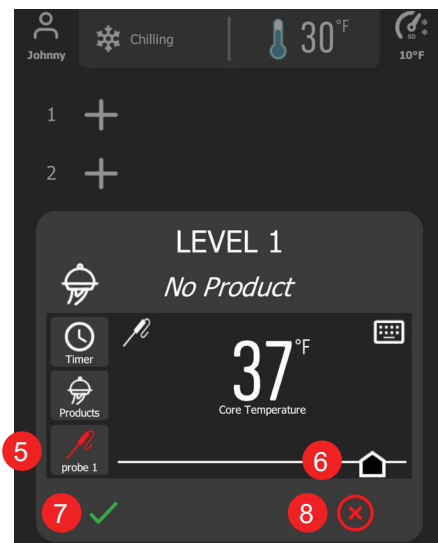
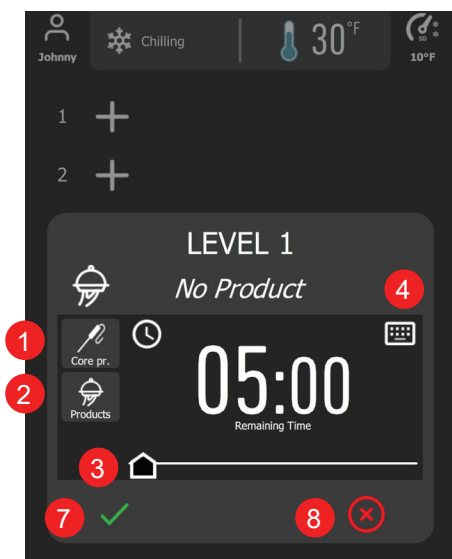

1. **Toggle Button:** Tap to switch between timer or core probe control.
2. **Products Button:** Turn on the product list and select product name for chilling.
3. **Slider:** Drag to change the cycle duration of the chosen level.
4. **Keypad:** Tap to turn on the virtual keypad to enter the cycle duration time of the chosen level.
5. **Probe Selection Button:** Tap to open the available core probes list to select.
6. **Slider:** Drag to change the core probe target temperature.
7. **Accept Button:** Tap to accept the level setup.
8. **Cancel Button:** Tap to discard all setups or changes.

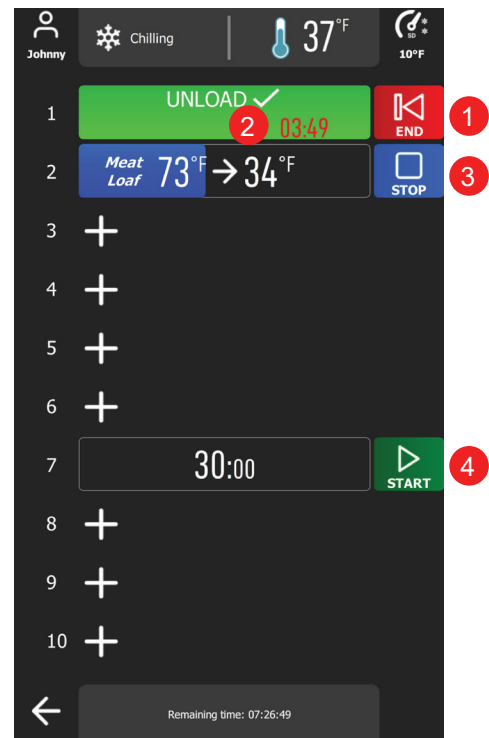

1. **End Button:** Cycle is complete, tap to end & save HACCP data
2. **Overtime Counter:** Product needs to be removed
3. **Stop Button:** Tap to cancel the ongoing cycle

IX. Operation (continued)

4. **Start Button:** Tap to start the timer/measure probe

IX. e - ADDING PRODUCT TO A CYCLE IN PROGRESS:

Additional products can be added to chill cycles already in progress when using either the **AUTO** or **MANUAL** mode.

For cycles started using either **AUTO** or **MANUAL**, simply insert an available probe into the new hot product to be added. The chiller will automatically add this probe to the cycle.

This can be repeated as long as there remains an available probe or zone to use with the new product.

IX. f - COLD HOLDING:

This is a refrigeration cycle of infinite duration that can precede all the operating cycles.

To initiate Cold Holding, simply press the Cold Holding button on the Home Screen.

Upon entering the Cold Holding page, users are required to set the cabinet temperature set point to hold the food at the temperature. Use the slider or press the keypad to set the holding temperature.

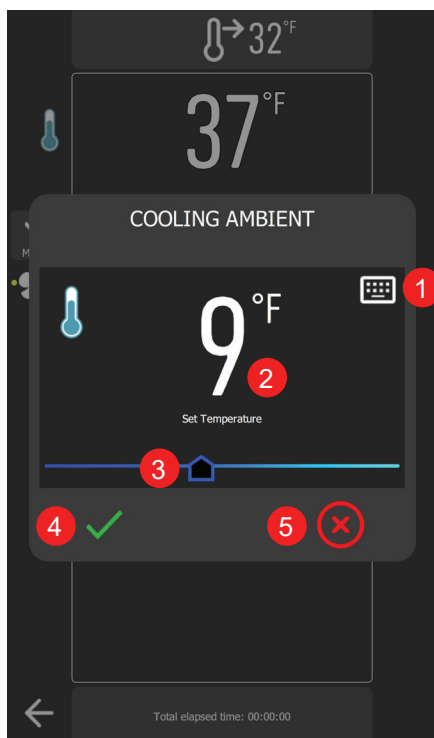

1. **Keypad:** Tap to turn on the virtual keypad for setting the cabinet temperature
2. Cabinet setpoint
3. **Temperature Slider:** Drag to adjust the cabinet settings
4. **Accept Button:** Tap to initiate the cold holding mode
5. **Cancel Button:** Tap to go back to the Home Page

When users press the Accept button, the Cold Holding cycle begins, and the following page will be displayed.

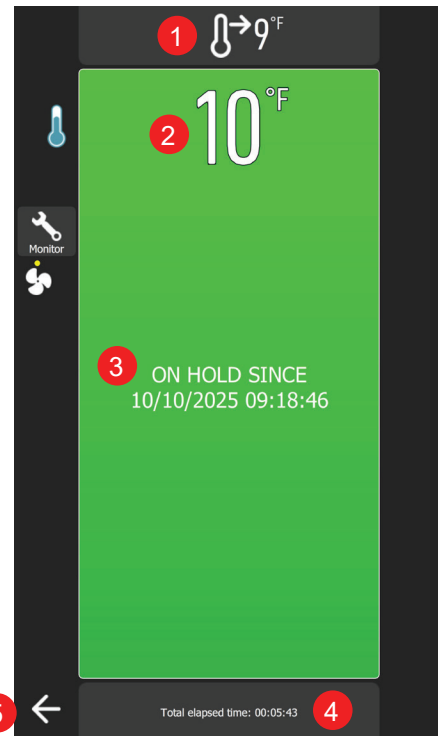

1. Current cabinet temperature setpoint
2. Real-time cabinet temperature
3. Cycle start time
4. Elapsed cycle duration
5. **Cancel Button:** Option to cancel Cold Holding and return to the Home page.

IX. g - FREEZING PRODUCT:

Freezing is done using the **MANUAL** mode. From the **MANUAL** programming screen...

- 1) Begin by inserting a probe into the product(s) to be frozen.
- 2) Press **MANUAL** then **TEMP**.
- 3) Adjust **SETTINGS** to desired target temp.
- 4) Select **METHOD** if other than **STANDARD** is needed.
- 5) Select active **PROBE**. Add operator and product name if desired.
- 6) Press **START**.

NOTE: Upon cycle completion the chiller will automatically enter "Maintenance Mode" where temperature is held between 0°F and 5°F after the blast freezing cycle.

IX. h - DEFROSTING:

A defrosting cycle can be initiated manually by pressing the **Defrost Button** on the Home Page, followed by the **Start Button**.

A defrost cycle can be started manually or automatically based on the 4-hour interval.

An automatic defrost cycle may occur during a Holding, Chilling cycle or Freezing cycle to ensure the evaporator coil remains clear and free of frost buildup.

IX. Operation (continued)

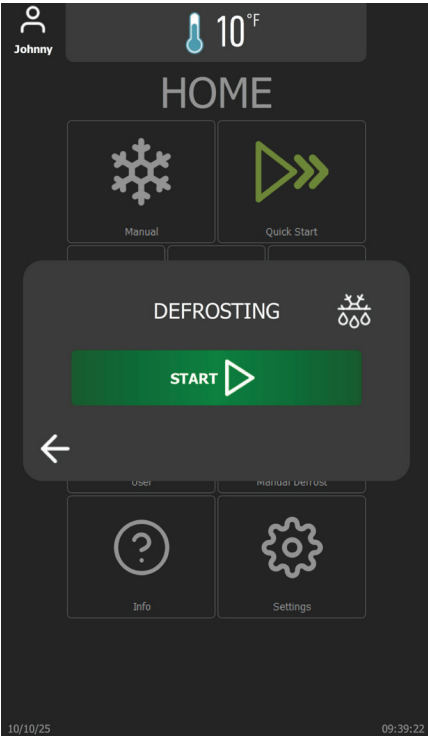

1. **Home Button:** Tap to return to the Home page.
2. **Filtering Buttons:** Tap to filter the HACCP records
3. **Date column:** Displays the start date of each recorded cycle
4. **Time column:** Displays the start time of each recorded cycle
5. **Control column:** Indicates whether the cycle was temperature or time-based
6. **Mode column:** Displays the selected chill mode (Standard, Speed, or Delicate)
7. **Operation column:** Displays the type of operation (Chill, Freeze, or Multi-Operation)
8. **Duration column:** Displays the total duration of the operation
9. **Return Button:** Tap to return to the Home Page
10. **Export Button:** Tap to export the data displayed in the list if USB device is plugged in

IX. j - TEMPERATURE CYCLE:

The HACCP record is displayed upon completion of a chill cycle (see figures below) or can be reviewed on the History page. After the cycle ends, users can modify the product name and user name. However, once the record is verified and saved, no further changes can be made.

IX. i - HACCP:

Traulsen's blast chiller is equipped with an advance history feature that records critical HACCP data during each blast chill cycle, automatically storing it in a secure database for easy access at any time. Users can conveniently reprint records or export the data via USB for external storage or compliance reporting. Additionally, the system allows users to enable or disable recording and customize the history retention period, providing flexibility and control over data management.

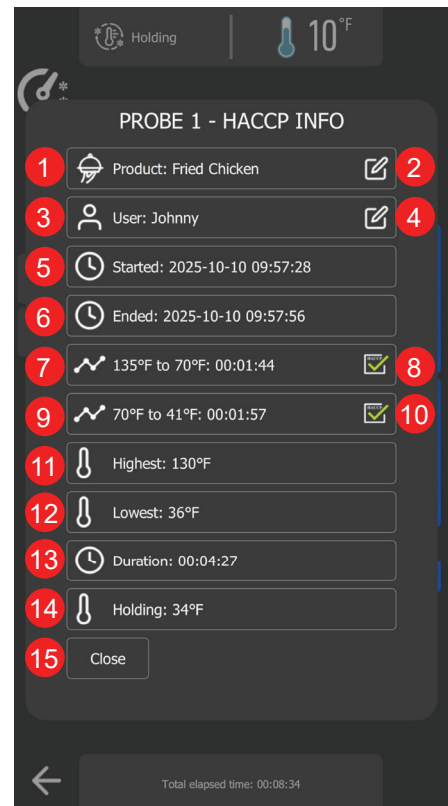
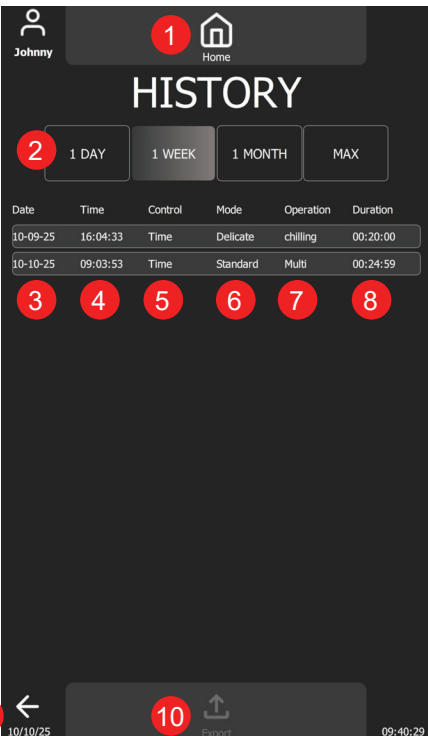

To view the complete cycle history, users can navigate to the History page by pressing the History button on the Home page. The following screen will be displayed.



1. **Product Name:** Displays the name of the chilled product
2. **Edit Button:** Tap to open the product name gallery for selection
3. **Active User:** Displays the name of the logged-in user
4. **Edit Button:** Tap to open the username gallery for selection
5. **Chill Start Time:** Date and time when the product chilling process began (YYYY-MM-DD HH:MM:SS).
6. **Chill End Time:** Date and time when the product reached the set target temperature (YYYY-MM-DD HH:MM:SS).
7. **Cooling Duration (135°F to 70°F):** Time taken to cool the product from 135°F to 70°F (HH:MM:SS).



IX. Operation (continued)

8. Cooling Compliance Indicator (135°F to 70°F):

-  Indicates the product cooled to 70°F within 2 hours.
-  Indicates the product did **not** meet the required cooling time.

9. Cooling Duration (70°F to 41°F): Time taken to cool the product from 70°F to 41°F (HH:MM:SS).

10. Cooling Compliance Indicator (135°F to 70°F):

-  Indicates the product cooled to 41°F within an additional 4 hours.
-  Indicates the product did not meet the required cooling time.

11. Highest Recorded Temperature: Displays the maximum temperature recorded during the cycle.

12. Lowest Recorded Temperature: Displays the minimum temperature recorded during the cycle.

13. Total Chill Time: The total duration required to complete the chilling process.

14. Holding Temperature: The set temperature to maintain after the chill cycle is complete.

15. Close Button: Tap to close the HACCP dialog.

IX. k - TIME CYCLE:

For time cycle, the HACCP record requires fewer parameters. However, the controller continues to record essential data. Refer to the figure below for more details.

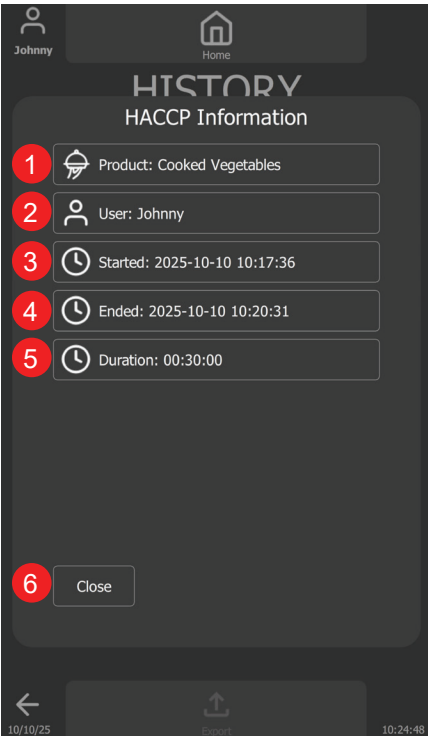

1. Product Name: Displays the name of the chilled product.

2. Active User: Displays the name of the logged-in user.

3. Chill Start Time: Date and time when the product chilling process began (YYYY-MM-DD HH:MM:SS).

4. Chill End Time: Date and time when the product reached the set target temperature (YYYY-MM-DD HH:MM:SS).

5. Total Chill Time: The total duration required to complete the chilling process.

6. Close Button: Tap to close the HACCP dialog.

IX. l - EXPORTED DATA:

The HACCP data can be exported into the USB device with the characteristics:

- Maximum capacity = 32 GB
- Formatted in FAT32 (default allocation unit size = 4096 bytes) or formatted in FAT (default allocation unit size = 32 Kilobytes)

The table below shows an example of exported HACCP data.

NOTE: 0 means core probe is not in used. Timer-based cycle was selected.

ID	Probe	Product	User	Start Time
1	1	Meat	Johnny	2025-01-...
2	0*	Fishes	Steven	2025-01-...
3	2	Egg	Henry	2025-01-...
4	0	Soup	Jace	2025-01-...
5	3	Steak	Jason	2025-01-...
6	0	Shrimps	Traulsen	2025-01-...

End Time	Phase 1	Phase 2	Duration
2025-01-...	01:50:00	03:45:57	05:35:57
2025-01-...	00:00:00	00:00:00	00:10:00
2025-01-...	01:50:00	03:45:57	05:35:57
2025-01-...	00:00:00	00:00:00	01:00:00
2025-01-...	01:50:00	03:45:57	05:35:57
2025-01-...	00:00:00	00:00:00	04:00:00

Max Temp	Min Temp	Hold Temp	Operation	Mode	Control
160	36	37	Multi	Standard	Temp
		37	Multi	Standard	Time
145	19	20	chilling	Speed	Auto
		37	chilling	Delicate	Time
100	34	34	Multi	Speed	Temp
			chilling	Standard	Time

IX. m - USERS:

The Users feature in the blast chiller allows for assigning and managing the active operator. This functionality helps streamline kitchen operations by clearly identifying the user responsible. By setting up an active operator, kitchen staff can track usage, maintain accountability, and ensure efficient workflow management within the kitchen environment.

Usernames can be easily added by selecting the desired name directly from the list. To remove a username, go to the Settings section.

IX. Operation (continued)

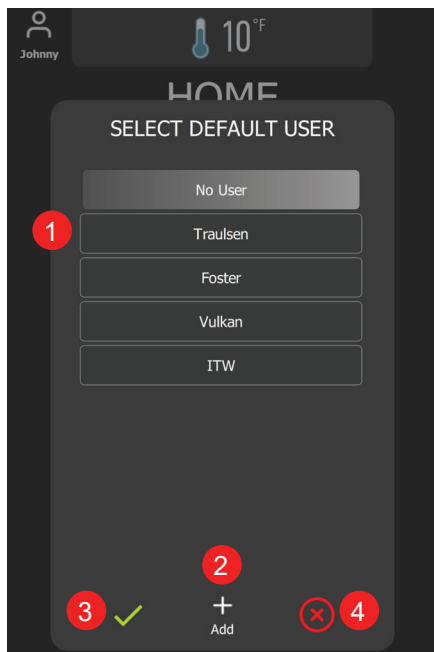

1. **User List:** Tap to select an active user.
2. **Add Button:** Tap to open the virtual keyboard to enter the new username.
3. **Accept Button:** Tap to accept the change and close.
4. **Cancel Button:** Tap to cancel and close.

IX. n - PRODUCTS:

The Products feature in the blast chiller allows users to select a default product name, making it ideal for those who consistently chill the same product. This feature streamlines operations by saving time and ensuring accuracy in product identification during repeated use.

Product names can be modified during or after a blast chill cycle, and additional product names can be added by selecting from the list. To remove a product name, go to the Settings section.

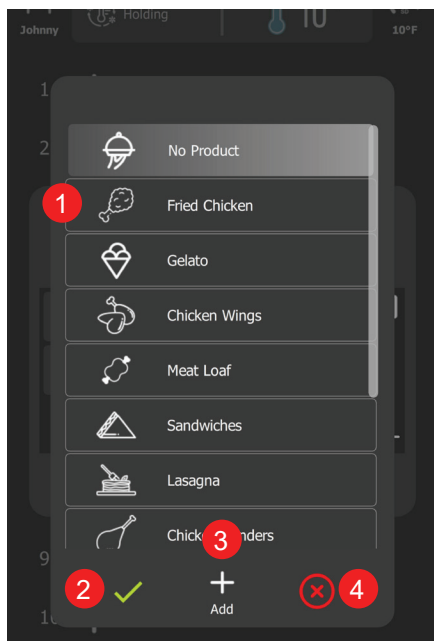

1. **Product List:** Tap to select an active product.

2. **Add Button:** Tap to open the virtual keyboard to enter the new product name.
3. **Accept Button:** Tap to accept the change and close.
4. **Cancel Button:** Tap to cancel and close.

IX. o - SETTINGS:

The **Settings Page** is divided into three main sections: **User Settings**, **Supervisor Settings**, and **Service Settings**. Each section is designed for streamlined configuration and management.

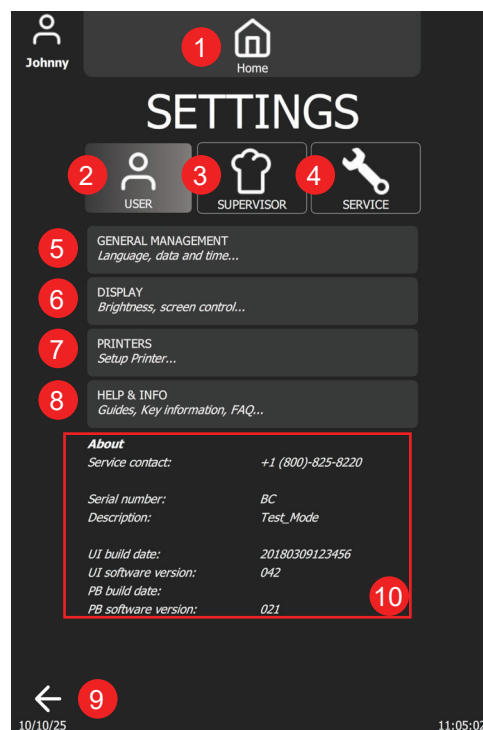

1. **Home Button:** Tap to return to Home Page
2. **User Button:** Tap to see all User Settings
3. **Supervisor Button:** Tap to access the Supervisor Settings (Password is 1234)
4. **Service Button:** Tap to access the Service Settings (Password is 4401)
5. **General Management Button:** Tap to modify general settings (see User Settings section)
6. **Display Button:** Tap to modify the Display Settings (see User Settings section)
7. **Printer Button:** The device supports both receipt & label printers via Bluetooth Classic. Compatible manufacturers & models are: **Epson TM-m30 ; Star Micronics mC-Print3 ; or Star Micronics mC-Label3**
8. **Help & Information Button:** Tap to open user manual
9. **Return Button:** Tap to return to the Home Page
10. **About Info:** Unit information

IX. p - GENERAL MANAGEMENT:

Continued on next page.

IX. Operation (continued)

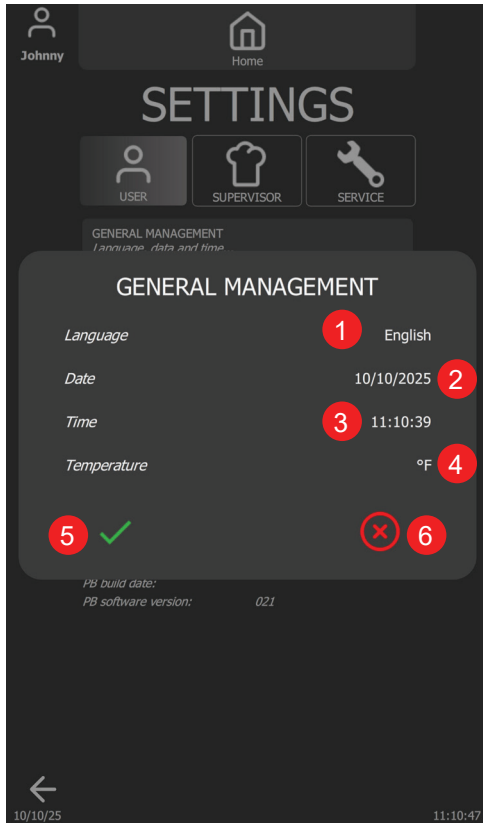

1. **Language List:** Tap to change current language (English, Spanish, French).
2. **Date:** Tap to change the current date (MM:DD:YYYY).
3. **Time:** Tap to change the current time (HH:MM:SS)
4. **Temperature Unit:** Tap to change the current measurement unit (Fahrenheit, Celsius)
5. **Accept Button:** Tap to accept all changes and close
6. **Cancel Button:** Tap to discard all changes and close

IX. q - DISPLAY:

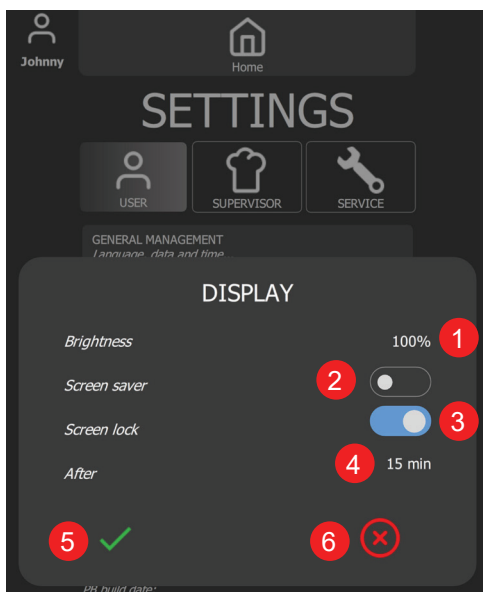

1. **Brightness Control:** Tap to change the display brightness
2. **Screen Saver Switch:** Tap to turn it on or off

3. **Screen Lock Switch:** Tap to turn it on or off
4. **Active Time:** Tap to change the active time to activate the screen saver and screen lock
5. **Accept Button:** Tap to accept all changes and close
6. **Cancel Button:** Tap to discard all changes and close

IX. r - PRINTERS:

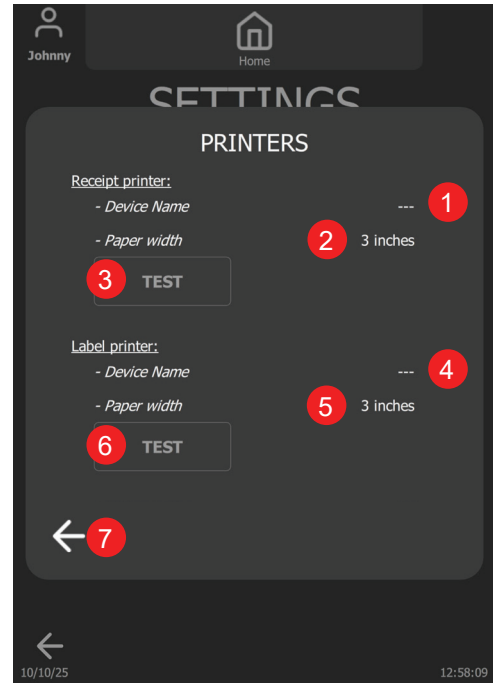

1. **Device Name:** Connected receipt printer name
2. **Paper Width:** Tap to select the receipt paper size
3. **Test Button:** Tap to print a test receipt
4. **Device Name:** Connected label printer name
5. **Paper Width:** Tap to select the label paper size
6. **Test Button:** Tap to print a test label
7. **Return Button:** Tap to close the dialog



1. Bluetooth device list

IX. Operation (continued)

2. **Accept Button:** Tap to accept the changes and close.
3. **Scan Button:** Tap to re-scan devices.
4. **Cancel Button:** Tap to discard all changes and close.

IX. s - SUPERVISOR SETTINGS:

Supervisor settings are secured and can only be modified by authorized kitchen personnel. To access the Supervisor settings, enter the default access code (1234).

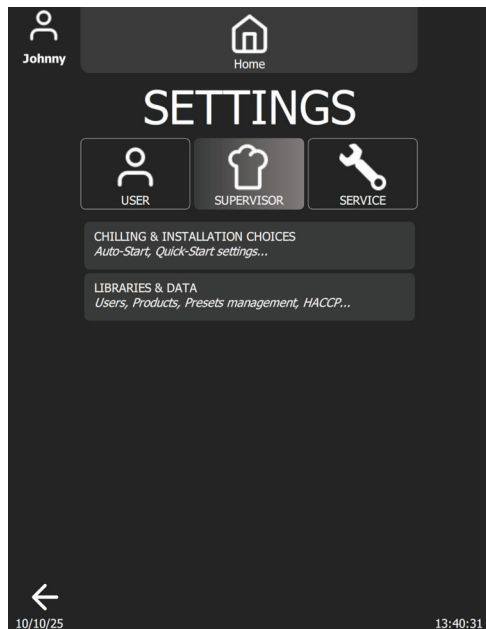

IX. t - CHILLING & INSTALLATION CHOICES:

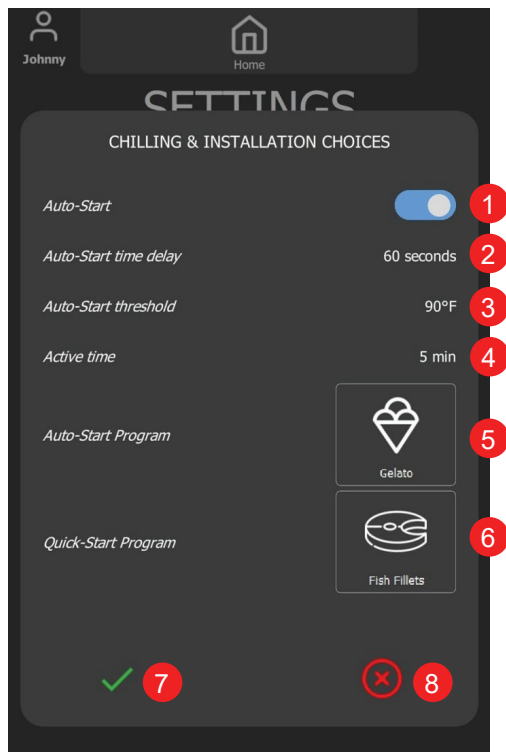

1. **Auto-Start Switch:** Enable or disable the feature.
2. **Auto-Start Time Delay:** Tap to turn on the virtual keypad to change the countdown timer until the blast chill cycle started automatically.

3. **Auto-Start Threshold:** Tap to turn on the virtual keypad to change the temperature threshold to trigger auto-start count down.
4. **Active Time:** Tap to turn on the virtual keypad to change the time to switch back to Home page and to trigger auto-start.
5. **Auto-Start Program:** Tap to change the Auto-Start program.
6. **Quick-Start Program:** Tap to change the Quick-Start program.
7. **Accept Button:** Tap to save all changes and close.
8. **Cancel Button:** Tap to discard all changes and close.

IX. u - LIBRARIES & DATA:

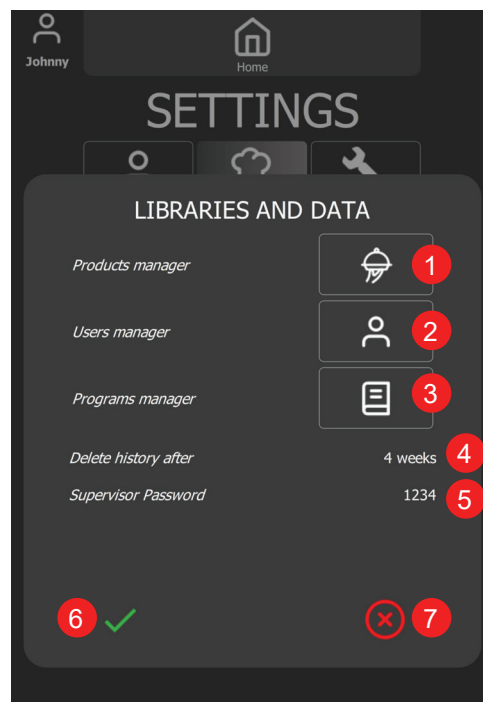

1. **Product Manager Button:** Tap to add or delete the Product names
2. **User Manager Button:** Tap to add or delete the usernames
3. **Program Manager Button:** Tap to manage the programs
4. **HACCP Record Retention Period:** Tap to adjust the record retention duration
5. **Supervisor Password:** Tap to change the password
6. **Accept Button:** Tap to accept all changes and close
7. **Cancel Button:** Tap to discard all changes and close

X. Service & Warranty Information

X. a) SERVICE INFORMATION

Before calling for service, please check the following:

Is the electrical cord plugged in? **NOTE:** If the SUPPLY CORD is damaged, it must be replaced by the manufacturer, its service agent, or similarly qualified persons in order to avoid a possible electrical hazard.

Is the fuse OK or circuit breaker on?

Is the condenser coil clean?

Is the power switch on?

If after checking the above items and the unit is still not operating properly, please contact an authorized Traulsen service agent: 4401 Blue Mound Road Fort Worth, TX 76106 | (800) 825-8220. Traulsen reserves the right to change specifications or discontinue models without notice.



NOTE: The ISO 7010-W021 symbol is a standardized safety sign used internationally to indicate a potential fire hazard. It features a black flame icon on a triangular yellow background with a black border, following ISO guidelines for warning symbols. This appliance is marked with the ISO 7010-W021 warning label to indicate the presence of **FLAMMABLE REFRIGERANTS**. Prior to beginning work on systems containing **FLAMMABLE REFRIGERANTS**, safety checks are necessary to ensure that the risk of ignition is minimized.

VENTILATED AREA

Ensure that the area is in the open or that it is adequately ventilated before breaking into the system or conducting any hot work. A degree of ventilation shall continue during the period that the work is carried out. The ventilation should safely disperse any released refrigerant and preferably expel it externally into the atmosphere.

CABLING

Check that cabling will not be subject to wear, corrosion, excessive pressure, vibration, sharp edges, or any other adverse environmental effects. The check shall also take into account the effects of aging or continual vibration from sources such as compressors or fans.

DETECTION OF FLAMMABLE REFRIGERANTS

Under no circumstances shall potential sources of ignition be used in the searching for or detection of refrigerant leaks. A halide torch (or any other detector using a naked flame) shall not be used.

The following leak detection methods are deemed acceptable for all refrigerant systems. Electronic leak detectors may be used to detect refrigerant leaks but, in the case of FLAMMABLE REFRIGERANTS, the sensitivity might not be adequate, or might need recalibration. (Detection equipment shall be calibrated in a refrigerant-free area.) Ensure that the detector is not a potential source of ignition and is suitable for the refrigerant used. Leak detection equipment shall be set at a percentage of the LFL of the refrigerant and shall be calibrated to the refrigerant employed, and the appropriate percentage of gas (25 % maximum) is confirmed.

Leak detection fluids are also suitable for use with most refrigerants but the use of detergents containing chlorine shall be avoided as the chlorine can react with the refrigerant and corrode the copper pipe-work.

NOTE: Examples of leak detection fluids are

- bubble method
- fluorescent method agents

If a leak is suspected, all naked flames shall be removed/extinguished.

X. Service & Warranty Information (continued)

If a leakage of refrigerant is found which requires brazing, all of the refrigerant shall be recovered from the system, or isolated (by means of shut off valves) in a part of the system remote from the leak. Removal of refrigerant shall be according to the removal & evacuation section below.

REMOVAL & EVACUATION

When breaking into the refrigerant circuit to make repairs- or for any other purpose - conventional procedures shall be used. However, for flammable refrigerants it is important that best practice be followed, since flammability is a consideration. The following procedure shall be adhered to:

- a) safely remove refrigerant following local and national regulations;
- b) purge the circuit with inert gas;
- c) evacuate
- d) purge with inert gas;
- e) open the circuit by cutting or brazing.

The refrigerant charge shall be recovered into the correct recovery cylinders if venting is not allowed by local and national codes. For appliances containing flammable refrigerants, the system shall be purged with oxygen- free nitrogen to render the appliance safe for flammable refrigerants. This process might need to be repeated several times. Compressed air or oxygen shall not be used for purging refrigerant systems .

For appliances containing flammable refrigerants, refrigerants purging shall be achieved by breaking the vacuum in the system with oxygen-free nitrogen and continuing to fill until the working pressure is achieved, then venting to atmosphere, and finally pulling down to a vacuum. This process shall be repeated until no refrigerant is within the system (optional for A2L). When the final oxygen-free nitrogen charge is used, the system shall be vented down to atmospheric pressure to enable work to take place.

Ensure that the outlet for the vacuum pump is not close to any potential ignition sources and that ventilation is available.

IX. b) SPARE PARTS INFORMATION

To purchase replacement parts or to speak to service support for Traulsen units please contact our Ft. Worth facility by phone at 800-825-8220 or fax to 817-740-6748 (parts) or 817-740-6757 (service).

Note: When calling for spare parts or service support, please make sure you have model and serial number of unit available.

The image shows a Traulsen service tag form. At the top left is the Traulsen logo. To the right of the logo is a QR code. Two blue arrows point from the QR code to the text 'Model Number' and 'Serial Number'. The form contains various fields for technical specifications, including refrigerant types and capacities, and a section for repair power supply information.

IX. c) WARRANTY REGISTRATION

The warranties for your new Traulsen unit may be registered with us by completing warranty information online, via our website www.Traulsen.com. Click on the Warranty Registration text of the Service tab at the top of the home page. You may also register your product by calling us directly at 800-825-8220.

XI. Troubleshooting

SYMPTOM	POTENTIAL CAUSE	SOLUTION
1. No display on control.	<ol style="list-style-type: none"> a. No power to unit. b. System problem. 	<p>Check power supply and circuit breaker. Call for service.</p>
2. Batch requires too much time to chill product down target temperature or time.	<ol style="list-style-type: none"> a. Door not closed properly. b. Too much product loaded. c. Product depth in pan exceeds 2". d. Pan has been covered with a lid, plastic wrap or foil, and this is not in direct contact with the product. 	<p>Close door completely. Adjust the load to not exceed capacity of the unit. Reduce pan load. Cover product correctly.</p>

XI. Troubleshooting (continued)

SYMPTOM	POTENTIAL CAUSE	SOLUTION
2. Batch requires too much time to chill product down target temperature or time (cont'd).	e. Product loaded is of a high density. f. Dirty condenser coil. g. Evaporator coil iced.	Allow additional chilling time. Clean condenser coil. Allow chiller to defrost.
3. Auto mode does not appear to work when placing probe in hot product.	a. Probe not available. b. Probe not placed in product. c. Food probe placed in product below 90° F. d. Damaged or defective food probe.	Press DONE to release probe for use. Place probe in product. Manually program cycle and select probe. Replace with new food probe.
4. Chill cycle starts with no product present.	a. Door open. b. Hot product inside but no probe placed.	Close door. Press CANCEL then place probe to start cycle.
5. Unwanted product freezing.	a. Previously chilled product not removed. b. Chill cycle By Time set for too long. c. High water content food (ex. soup).	Remove DONE product before starting a new chill cycle. Reduce cycle time. Use DELICATE method.
6. Food drying out during chilling.	a. Food chilled uncovered.	Cover food before placing in chiller.
7. Condensation on exterior surface.	a. Door out of alignment or gasket issue. b. Door sweep worn/out of adjustment (TBC1H). c. Electric door heater malfunction.	Check door alignment and gasket for proper seal. Adjust/replace door sweep. Call for service.
8. Upon starting a chill cycle, the product temperature displayed appears cooler than expected (cooked) temperature.	a. Varied product temps within batch. b. Probe placed incorrectly. c. Small mass product (ex. chicken tender). d. Product held at room temp too long.	Verify actual product temp using a manual thermometer. Relocate probe. Use chill by time. Verify actual product temp using a manual thermometer.

XII. TBC13 Condensate Kit Install Instructions

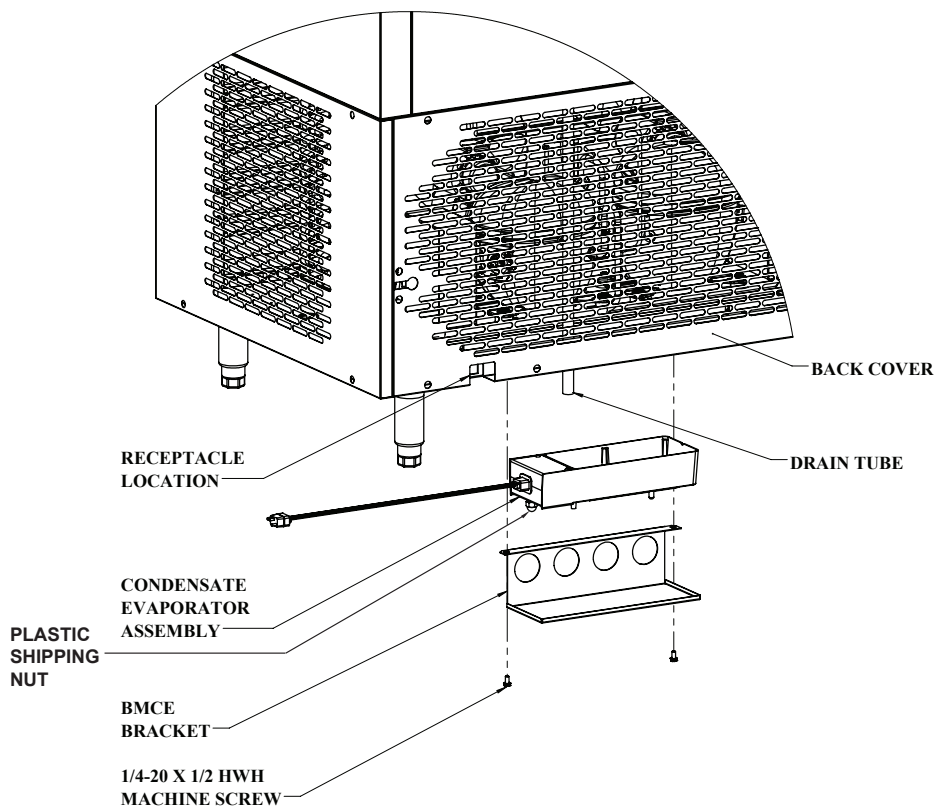

1. Install the unit on its supports (casters/legs).
2. Locate the mounting holes on the system base under the unit (behind the caster/leg channel).
3. Mount the BMCE bracket with provided screws (1/4"-20 X 1/2" hex head).
4. Place the condensate evaporator assembly onto the BMCE bracket with the plug facing the receptacle location (see drawing).
5. Insert the plug into the receptacle, ensuring it is fully inserted.
6. Place the loose end of the plastic drain tube into the condensate evaporator assembly.
7. If condensate evaporator assembly cord interferes with caster movement, secure it to the back cover using wire ties.
8. Verify that the heater is working. If it is not, the plug is not fully inserted into the receptacle or it needs to be reinserted the other direction.
9. Remove black plastic shipping nut from the bottom of condensate pan.

4401 Blue Mound Road Fort Worth, Texas 76106 (USA)
Phone: 800.825.8220 | Service Fax: 817.740.6757 | E-mail: service@traulsen.com | Website: traulsen.com

Form Number: TR35938 | Part Number: 375-60311-00 | Revision Date: 03/26

Traulsen © All Rights Reserved

