

Save This Manual  
For Future Reference

**SEARS**

*owners  
manual*

**MODEL NO.  
113.221611**

Serial  
Number \_\_\_\_\_

Model and serial  
number may be found  
at the rear of the base.

You should record both  
model and serial number  
in a safe place for  
future use.

**CAUTION:**

**READ ALL  
INSTRUCTIONS  
CAREFULLY**

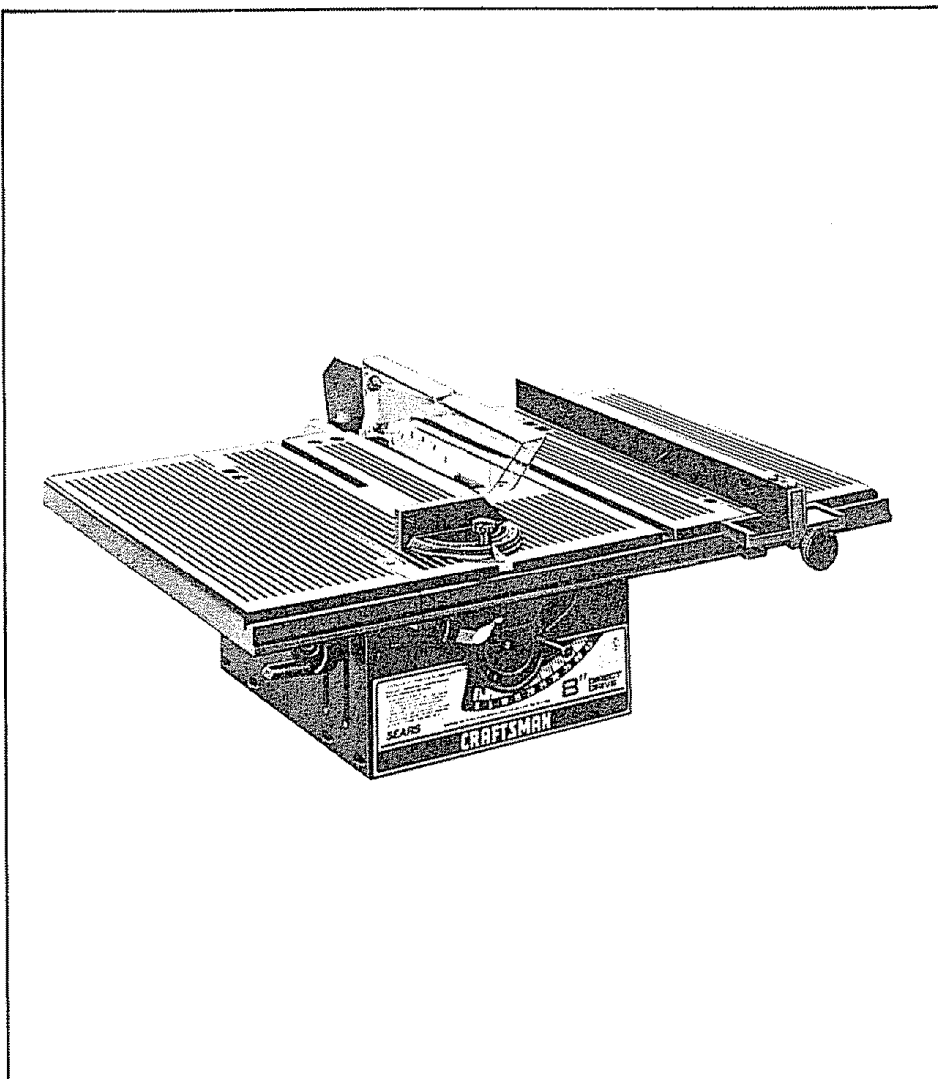

**CRAFTSMAN**

**8 INCH DIRECT DRIVE  
TABLE SAW**

- *assembly*
- *operating*
- *repair parts*

Sold by SEARS, ROEBUCK AND CO., Chicago, IL. 60684 U.S.A.

Part No. SP5022

Printed in U.S.A.

### FULL ONE YEAR WARRANTY ON CRAFTSMAN TABLE SAW

If within one year from the date of purchase, this Craftsman Table Saw fails due to a defect in material or workmanship, Sears will repair it, free of charge.

WARRANTY SERVICE IS AVAILABLE BY RETURNING THE TABLE SAW TO THE NEAREST SEARS RETAIL/CATALOG STORE OR SERVICE CENTER/DEPARTMENT IN THE UNITED STATES.

This warranty gives you specific legal rights and you may also have other rights which vary from state to state.

SEARS, ROEBUCK AND CO., Sears Tower, BSC 41-3, Chicago, IL 60684

## GENERAL SAFETY INSTRUCTIONS FOR POWER TOOLS

- 1. KNOW YOUR POWER TOOL**  
Read and understand the owner's manual and labels affixed to the tool. Learn its application and limitations as well as the specific potential hazards peculiar to this tool.
- 2. GROUND ALL TOOLS**  
This tool is equipped with an approved 3-conductor cord and a 3-prong grounding type plug to fit the proper grounding type receptacle. The green conductor in the cord is the grounding wire. Never connect the green wire to a live terminal.
- 3. KEEP GUARDS IN PLACE**  
In working order, and in proper adjustment and alignment.
- 4. REMOVE ADJUSTING KEYS AND WRENCHES**  
Form habit of checking to see that keys and adjusting wrenches are removed from tool before turning it on.
- 5. KEEP WORK AREA CLEAN**  
Cluttered areas and benches invite accidents. Floor must not be slippery due to wax or sawdust.
- 6. AVOID DANGEROUS ENVIRONMENT**  
Don't use power tools in damp or wet locations or expose them to rain. Keep work area well lighted. Provide adequate surrounding work space.
- 7. KEEP CHILDREN AWAY**  
All visitors should be kept a safe distance from work area.
- 8. MAKE WORKSHOP CHILD-PROOF**  
— with padlocks, master switches, or by removing starter keys.
- 9. DON'T FORCE TOOL**  
It will do the job better and safer at the rate for which it was designed.
- 10. USE RIGHT TOOL**  
Don't force tool or attachment to do a job it was not designed for.
- 11. WEAR PROPER APPAREL**  
Do not wear loose clothing, gloves, neckties or jewelry (rings, wrist watches) to get caught in moving parts. Non-slip footwear is recommended. Wear protective hair covering to contain long hair. Roll long sleeves above the elbow.
- 12. USE SAFETY GOGGLES (Head Protection)**  
Wear Safety goggles (must comply with ANSI Z87.1) at all times. Everyday eyeglasses only have impact resistant lenses, they are NOT safety glasses. Also, use face or dust mask if cutting operation is dusty, and ear protectors (plugs or muffs) during extended periods of operation.
- 13. SECURE WORK**  
Use clamps or a vise to hold work when practical. It's safer than using your hand, frees both hands to operate tool.
- 14. DON'T OVERREACH**  
Keep proper footing and balance at all times.
- 15. MAINTAIN TOOLS WITH CARE**  
Keep tools sharp and clean for best and safest performance. Follow instructions for lubricating and changing accessories.
- 16. DISCONNECT TOOLS**  
Before servicing; when changing accessories such as blades, bits, cutters, etc.
- 17. AVOID ACCIDENTAL STARTING**  
Make sure switch is in "OFF" position before plugging in.
- 18. USE RECOMMENDED ACCESSORIES**  
Consult the owner's manual for recommended accessories. Follow the instructions that accompany the accessories. The use of improper accessories may cause hazards.
- 19. NEVER STAND ON TOOL**  
Serious injury could occur if the tool is tipped or if the cutting tool is accidentally contacted.  
  
Do not store materials above or near the tool such that it is necessary to stand on the tool to reach them.
- 20. CHECK DAMAGED PARTS**  
Before further use of the tool, a guard or other part that is damaged should be carefully checked to ensure that it will operate properly and perform its intended function. Check for alignment of moving parts, binding of moving parts, breakage of parts, mounting, and any other conditions that may affect its operation. A guard or other part that is damaged should be properly repaired or replaced.
- 21. DIRECTION OF FEED**  
Feed work into a blade or cutter against the direction of rotation of the blade or cutter only.
- 22. NEVER LEAVE TOOL RUNNING UNATTENDED**  
Turn power off. Don't leave tool until it comes to a complete stop.

# ADDITIONAL SAFETY INSTRUCTIONS FOR TABLE SAWS

**WARNING: FOR YOUR OWN SAFETY, DO NOT OPERATE YOUR SAW UNTIL IT IS COMPLETELY ASSEMBLED AND INSTALLED ACCORDING TO THE INSTRUCTIONS . . . AND UNTIL YOU HAVE READ AND UNDERSTAND THE FOLLOWING:**

1. **GENERAL SAFETY INSTRUCTIONS FOR POWER TOOLS . . . SEE PAGE 2**
2. **GETTING TO KNOW YOUR SAW . . . SEE PAGE 20**
3. **BASIC SAW OPERATION . . . SEE PAGE 23**
4. **MAINTENANCE . . . SEE PAGE 31**
5. **STABILITY OF SAW**

If there is any tendency for the saw to tip over or move during certain cutting operations such as cutting extremely large heavy panels or long heavy boards, the saw should be bolted down.

If you attach any kind of auxiliary table extensions over 24" wide to either end of the saw, make sure you either bolt the saw to the bench or floor as appropriate, or support the outer end of the extension from the bench or floor, as appropriate.

## 6. LOCATION

The saw should be positioned so neither the operator nor a casual observer is forced to stand in line with the saw blade.

## 7. KICKBACKS

A "KICKBACK" occurs during a rip-type operation when a part or all of the workpiece is violently thrown back toward the operator.

Keep your face and body to one side of the sawblade, out of line with a possible "Kickback." Kickbacks — and possible injury from them — can usually be avoided by:

- A. Maintaining the rip fence parallel to the sawblade.
- B. Keeping the sawblade sharp. Replace or sharpen antikickback pawls when points become dull.
- C. Keeping sawblade guard, spreader, and antikickback pawls in place and operating properly. The spreader must be in alignment with the sawblade and the pawls must stop a kickback once it has started. Check their action before ripping.
- D. NOT ripping work that is twisted or warped or does not have a straight edge to guide along the rip fence.
- E. NOT releasing work until you have pushed it all the way past the sawblade.
- F. Using a push stick for ripping widths of 2 to 6 in., and an auxiliary fence and push block for ripping widths narrower than 2 in. (See "Basic Saw Operation Using The Rip Fence" section.)
- G. NOT confining the cut-off piece when ripping or cross-cutting.
- H. When ripping apply the feed force to the section of the workpiece between the saw blade and the rip fence.

## 8. PROTECTION: EYES, HANDS, FACE, EARS, BODY

- A. If any part of your saw is malfunctioning, has

been damaged or broken . . . such as the motor switch, or other operating control, a safety device or the power cord . . . cease operating immediately until the particular part is properly repaired or replaced.

- B. Wear safety goggles that comply with ANSI Z87.1, and a face shield if operation is dusty. Wear ear plugs or muffs during extended periods of operation.
- C. Small loose pieces of wood or other objects that contact the rear of the revolving blade can be thrown back at the operator at very high speed. This can usually be avoided by keeping the guard and spreader in place for all thru-sawing operations (sawing entirely thru the work) AND by removing all loose pieces from the table with a long stick of wood IMMEDIATELY after they are cut off.
- D. Use extra caution when the guard assembly is removed for resawing, dadoing, rabbeting, or molding — replace the guard as soon as that operation is completed.
- E. For rip or rip-type cuts, the following end of a workpiece to which a push stick or push board is applied must be square (perpendicular to the fence) in order that feed pressure applied to the workpiece by the push stick or block does not cause the workpiece to come away from the fence, and possibly cause a kickback.
- F. During rip and rip type cuts, the workpiece must be held down on the table and against the fence with a push stick, push block, and/or featherboards. A featherboard is made of solid lumber per sketch.

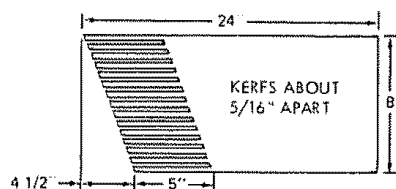

- G. NEVER turn the saw "ON" before clearing the table of all tools, wood scraps, etc., except the workpiece and related feed or support devices for the operation planned.
- H. NEVER place your face or body in line with the cutting tool.
- I. NEVER place your fingers or hands in the path of the sawblade or other cutting tool.
- J. NEVER reach in back of the cutting tool with either hand to hold down or support the workpiece, remove wood scraps, or for any other reason. Avoid awkward operations and hand positions where a sudden slip could cause fingers or hand to move into a sawblade or other cutting tool.
- K. DO NOT perform layout, assembly, or setup work on the table while the cutting tool is rotating.
- L. DO NOT perform any operation "FREEHAND" — always use either the rip fence or the miter gauge to position and guide the work.

M NEVER use the rip fence when crosscutting or the miter gauge when ripping. DO NOT use the rip fence as a length stop.

Never hold onto or touch the "free end" of the workpiece or a "free piece" that is cut off, while power is "ON" and/or the sawblade is rotating.

N. Shut "OFF" the saw and disconnect the power cord when removing the table insert, changing the cutting tool, removing or replacing the blade guard, or making adjustments.

O. Provide adequate support to the rear and sides of the saw table for wider or long workpieces.

P. Plastic and composition (like hardboard) materials may be cut on your saw. However, since these are usually quite hard and slippery, the antikickback pawls may not stop a kickback.

Therefore, be especially attentive to following proper set-up and cutting procedures for ripping. Do not stand, or permit anyone else to stand, in line with a potential kickback.

Q If you stall or jam the sawblade in the workpiece, turn saw "OFF", remove the workpiece from the sawblade, and check to see if the sawblade is parallel to the miter gauge grooves and if the spreader is in proper alignment with the sawblade. If ripping at the time, check to see if the rip fence is parallel with the sawblade. Readjust as indicated.

R. DO NOT remove small pieces of cut-off material that may become trapped inside the blade guard while the saw is running. This could endanger your hands or cause a kickback. Turn saw "OFF" and wait until blade stops.

S. Use extra care when ripping wood that has a twisted grain or is twisted or bowed — it may rock on the table and/or pinch the sawblade.

T Never gang crosscut or rip — lining up more than one workpiece in front of the blade (stacked vertically, or horizontally outward on the table) and then pushing through sawblade. The blade could pick up one or more pieces and cause a binding or loss of control and possible injury.

### 9. KNOW YOUR CUTTING TOOLS

A. Dull, gummy, or improperly sharpened or set cutting tools can cause material to stick, jam, stall the saw, or kickback at the operator.

Minimize potential injury by proper cutting tool and machine maintenance.

NEVER ATTEMPT TO FREE A STALLED SAWBLADE WITHOUT FIRST TURNING THE SAW OFF.

B. Never use grinding wheels, abrasive cut-off wheels, friction wheels (metal slitting blades) wire wheels or buffing wheels.

### 10. USE ONLY ACCESSORIES DESIGNED FOR THIS SAW.

11. Make sure the top of the arbor or cutting tool rotates toward you when standing in normal operating position. Also make sure the cutting tool, arbor collars and arbor nut are installed properly. Keep the cutting tool as low as

possible for the operation being performed. Keep all guards in place whenever possible.

12. Do not use any blade or other cutting tool marked for an operating speed less than 3450 RPM. Never use a cutting tool larger in diameter than the diameter for which the saw was designed. For greatest safety and efficiency when ripping, use the maximum diameter blade for which the saw is designed, since under these conditions the spreader is nearest the blade.

13. NEVER operate the saw unless the proper insert is installed.

14. NEVER feed material into the cutting tool from the rear of the saw. An accident and serious injury could result.

15. NEVER use another person as a substitute for a table extension, or as additional support for a workpiece that is longer or wider than the basic saw table, or to assist in feeding or supporting or pulling the workpiece.

DO NOT pull the workpiece through the sawblade — position your body at the nose (in-feed) side of the guard: start and complete the cut from the same side. This will require added table support for long or wide workpieces that extend beyond the length or width of the saw table.

### 16. THINK SAFETY.

Safety is a combination of operator common sense and alertness at all times when the saw is being used.

### 17. NOTE AND FOLLOW SAFETY INSTRUCTIONS THAT APPEAR ON THE FRONT OF YOUR SAW.

<b>DANGER</b> FOR YOUR OWN SAFETY:	
READ AND UNDERSTAND OWNERS MANUAL BEFORE OPERATING MACHINE	
1. WEAR SAFETY GOGGLES.	5. KNOW HOW TO AVOID "KICKBACKS."
2. USE SAWBLADE GUARD FOR "THRU SAWING."	6. DO NOT PERFORM OPERATIONS "FREEHAND."
3. KEEP HANDS OUT OF PATH OF SAWBLADE.	7. NEVER REACH AROUND OR OVER SAWBLADE.
4. USE A "PUSH STICK" WHEN REQUIRED.	
WARNING: USE 120 VOLT 15 AMP BRANCH CIRCUIT AND USE 15 AMP TIME DELAY FUSE.	

18. WARNING: DO NOT ALLOW FAMILIARITY (GAINED FROM FREQUENT USE OF YOUR SAW) TO BECOME COMMONPLACE. — ALWAYS REMEMBER THAT A CARELESS FRACTION OF A SECOND IS SUFFICIENT TO INFLICT SEVERE INJURY.

NOTE: Do not overtighten arbor nut. Use the arbor wrench to just "snug" it.



The operation of any power tool can result in foreign objects being thrown into the eyes, which can result in severe eye damage. Always wear safety goggles complying with ANSI Z87.1 (shown on Package) before commencing power tool operation. Safety Goggles are available at Sears retail or catalog stores.

# MOTOR SPECIFICATIONS AND ELECTRICAL REQUIREMENTS

## MOTOR SPECIFICATIONS

The AC motor used in this saw is a non-reversible type, with the following specifications:

Amperes .....	7.8
Hertz .....	60
Phase .....	Single
RPM .....	3450
Rotation (viewed from Sawblade end) .....	Counterclockwise

## MOTOR SAFETY PROTECTION

### MOTOR SAFETY PROTECTION

1. REPEATED STALLING OF THE SAW BLADE WILL **SHORTEN** THE LIFE OF THE MOTOR. Always avoid stalling the blade. If the motor has been abused (repeated stalling) and fails to start (hums), TURN THE SWITCH OFF, ALLOW THE MOTOR TO COOL, THEN RE-START IT.
2. ALWAYS USE SHARP BLADES. A dull blade requires excessive power and does not produce quality results.
3. **NOTE:** The starting relay is a GRAVITY SENSITIVE TYPE. NEVER TURN THE POWER ON WHILE THE SAW IS UPSIDE DOWN AS THIS WILL DAMAGE THE MOTOR.
4. Frequent opening of fuses or circuit breakers may result if motor is overloaded, or if the motor circuit is fused with a fuse other than those recommended. Do not use a fuse of greater capacity without consulting the power company.
5. Although the motor is designed for operation on the voltage and frequency specified on motor nameplate, normal loads will be handled safely on voltages not more than 10% above or below the nameplate voltage.  
Heavy loads, however, require that voltage at motor terminals be not less than the voltage specified on nameplate.
6. Most motor troubles may be traced to loose or incorrect connections, overloading, reduced input voltage (which results when small size wires are used in the supply circuit) or when the supply circuit is extremely long. Always check connection, load and supply circuit when the motor fails to perform satisfactorily. Check wire sizes and lengths with table at end of this section.

### CONNECTING TO POWER SUPPLY OUTLET

If power cord is worn or cut, or damaged in any way, have it replaced immediately.

**WARNING: IF NOT PROPERLY GROUNDED THIS POWER TOOL CAN CAUSE AN ELECTRICAL SHOCK PARTICULARLY WHEN USED IN DAMP LOCATIONS CLOSE TO PLUMBING. IF AN ELECTRICAL SHOCK OCCURS THERE IS THE POTENTIAL OF A SECONDARY HAZARD SUCH AS YOUR HANDS CONTACTING THE SAW BLADE.**

If you are not sure that your outlet, as pictured below, is properly grounded, have it checked by a qualified electrician.

Your unit is for use on 110-120 volts, and has a plug that looks like illustration below.

This power tool is equipped with a 3-conductor cord and grounding type plug which has a grounding prong, approved by Underwriters' Laboratories and

the Canadian Standards Association. The ground conductor has a green jacket and is attached to the tool housing at one end and to the ground prong in the attachment plug at the other end.

This plug requires a mating 3-conductor grounded type outlet as shown.

**WARNING: DO NOT PERMIT FINGERS TO TOUCH THE TERMINALS OF PLUGS WHEN INSTALLING OR REMOVING THE PLUG TO OR FROM THE OUTLET.**

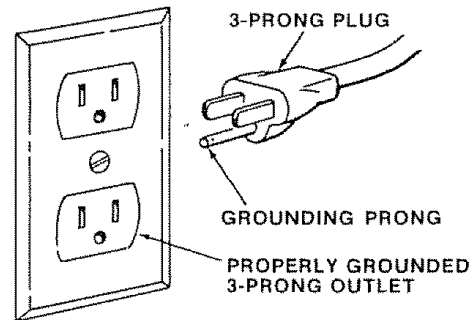

Plug power cord into a 110-120V properly grounded type outlet protected by a 15-amp. dual element time delay or Circuit-Saver fuse or circuit breaker. If the outlet you are planning to use for this power tool is of the 2 prong type, DO NOT REMOVE OR ALTER THE GROUNDING PRONG IN ANY MANNER. Use an adapter as shown below and always connect the grounding lug to known ground.

A temporary adapter as shown below is available for connecting plugs to 2-prong receptacles. The green grounding lug extending from the adapter must be connected to a permanent ground such as to a properly grounded outlet box.

A temporary adapter as illustrated is available for connecting plugs to 2-prong receptacles. The temporary adapter should be used only until a properly grounded outlet can be installed by a qualified electrician.

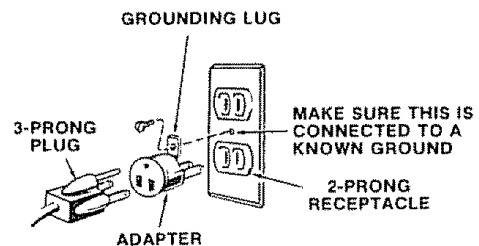

**WARNING: THE GREEN GROUNDING LUG EXTENDING FROM THE ADAPTER MUST BE CONNECTED TO A PERMANENT GROUND SUCH AS TO A PROPERLY GROUNDED OUTLET BOX. NOT ALL OUTLET BOXES ARE PROPERLY GROUNDED.**

If you are not sure that your outlet box is properly grounded, have it checked by a qualified electrician.

**NOTE:** The adapter illustrated is for use only if you already have a properly grounded 2-prong receptacle. Adapter is not allowed in Canada by the Canadian Electrical Code.

The use of any extension cord will cause some loss of power. To keep this to a minimum and to prevent over-heating and motor burn-out, use the following table to determine the minimum wire size (A.W.G.) extension cord.

Use only 3 wire extension cords which have 3-prong

grounding type plugs and 3-pole receptacles which accept the tools plug.

Extension Cord Length	Wire Size A.W.G.
Up to 100 Ft.	14
100-200 Ft.	12
200-400 Ft.	8

## CONTENTS

WARRANTY	2
GENERAL SAFETY INSTRUCTIONS FOR POWER TOOLS	2
ADDITIONAL SAFETY INSTRUCTIONS FOR TABLE SAWS	3
MOTOR SPECIFICATIONS AND ELECTRICAL REQUIREMENTS	5
UNPACKING AND CHECKING CONTENTS	6
Tools Needed	6
List of Loose Parts	7
ASSEMBLY	7
Installing Handwheels	7
Adjusting Blade Insert	8
Checking Heeling or Parallelism of Saw Blade to Miter Gauge Groove	9
Adjusting Parallelism of Saw Blade to Miter Gauge Groove	9
Adjusting 90 Degree Bevel Stop	10
Adjusting Bevel Pointer	11
Adjusting 45 Degree Bevel Stop	12
Installing Table Extensions	12
Aligning Table Extensions	13
To Raise Extension	13
To Lower Extension	14
Leveling Extensions	14
To Lower Outer Edge of Extension	14
To Raise Outer Edge of Extension	14
Aligning Table Extensions with Front of Table	15
To Move Outer Edge of Extension Back	15
To Move Outer Edge of Extension Forward	15
Installing Blade Guard	16
Aligning Spreader	17
Attaching Rip Fence	18
Aligning Rip Fence	19
Adjusting Miter Gauge	19
Mounting Saw to Legs or Bench	19

GETTING TO KNOW YOUR SAW	20
On-Off Switch	20
Elevation Handwheel	21
Tilt Handwheel	21
Miter Gauge	21
Blade Guard	21
Table Insert	21
Rip Fence	21
Removing and Installing Saw Blade	21
To Install Saw Blade	22
BASIC SAW OPERATION USING THE MITER GAUGE	23
Work Helpers	23
Crosscutting	24
Repetitive Cutting	25
Miter Cutting	25
Bevel Crosscutting	26
Compound Miter Cutting	26
BASIC SAW OPERATION USING THE RIP FENCE	26
Ripping	27
Bevel Ripping	27
Ploughing and Molding	29
Resawing	29
Rabbeting	30
Dadoing	30
Molding and Cutting	30
Using Featherboards	31
MAINTENANCE	31
LUBRICATION	32
RECOMMENDED ACCESSORIES	33
TROUBLE SHOOTING	33
REPAIR PARTS	35

## UNPACKING AND CHECKING CONTENTS

### TOOLS NEEDED

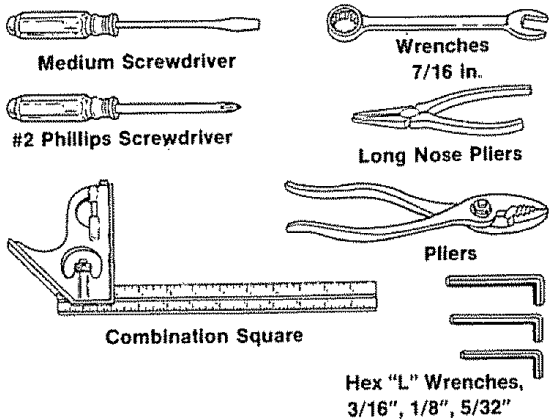

### COMBINATION SQUARE MUST BE TRUE.

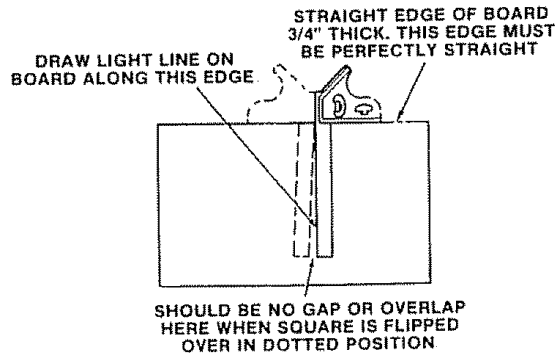

Model 113 221611 Table Saw with Table Extensions is shipped complete in one carton.

Separate all parts from packing materials and check each one with the illustration and the list of Loose Parts to make certain all items are accounted for, before discarding any packing material.

If any parts are missing, do not attempt to assemble the table saw, plug in the power cord or turn the switch on until the missing parts are obtained and are installed correctly.

Apply a coat of automobile wax to the table.

Wipe all parts thoroughly with a clean, dry cloth.

**WARNING: FOR YOUR OWN SAFETY, NEVER CONNECT PLUG TO POWER SOURCE OUTLET UNTIL ALL ASSEMBLY STEPS ARE COMPLETE, AND YOU HAVE READ AND UNDERSTAND THE SAFETY AND OPERATIONAL INSTRUCTIONS.**

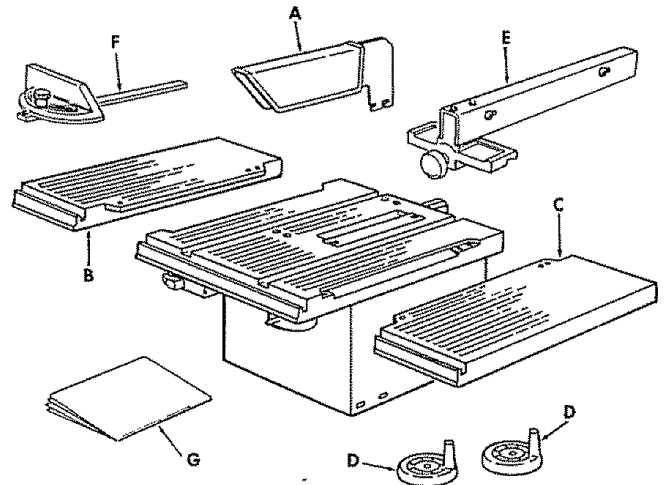

**LIST OF LOOSE PARTS**

ITEM	DESCRIPTION	QTY.
A	Guard Assembly .....	1
B	Extension Table L.H. ....	1
C	Extension Table R.H. ....	1
D	Handwheel .....	2
E	Rip Fence Assembly .....	1
F	Miter Gauge Assembly .....	1
G	Owners Manual .....	1

**Loose Parts Bag No. 507545**

(Containing the following items):

H	Wrench, Arbor .....	1
J	Wrench, Shaft .....	1
K	Support, Spreader .....	1
L	Bracket, Spreader .....	1
M	Clamp, Spreader .....	1
N	Nut, Wing 1/4-20 .....	2

**Loose Parts Bag No. 507546**

(Containing the following items):

O	Washer, 17/64 x 9/16 x 3/64 .....	4
P	Screw, Pan Hd. 8-32 x 3/8 .....	2
Q	Nut, Sq. 1/4-20 .....	2
R	Screw, Soc. Set 1/4-20 x 7/8 .....	2
S	Lockwasher, Ext. 1/4 .....	4
S	Lockwasher, Ext. #8 .....	2
T	Nut, Hex 1/4-20 .....	2
U	Screw, Truss Hd 1/4-20 x 5/8 .....	2
V	Screw, Flat Hd. 1/4-20 x 5/8 .....	14
W	Key, Switch .....	1

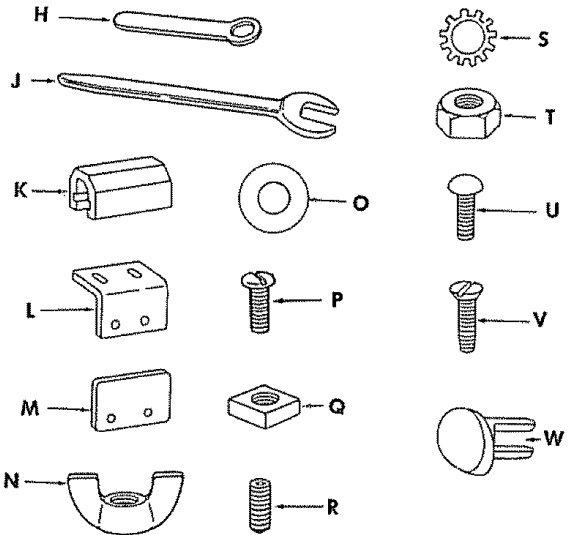

## ASSEMBLY

### INSTALLING HANDWHEELS

1. From among the loose parts find two #8 external lockwashers and two 8-32 x 3/8 inch long Phillips screws.
2. Install elevation handwheel onto elevation shaft by lining up FLAT SPOT on shaft with flat inside handwheel. Install screw and lockwasher.
3. Install bevel handwheel onto bevel shaft by lining up FLAT SPOT on shaft with flat inside handwheel. Install screw and lockwasher.

**WARNING: Failure to complete the following two steps could result in damage to your saw.**

4. Turn elevation handwheel counter-clockwise to pull motor away from inner packing cardboard.
5. Remove cardboard.

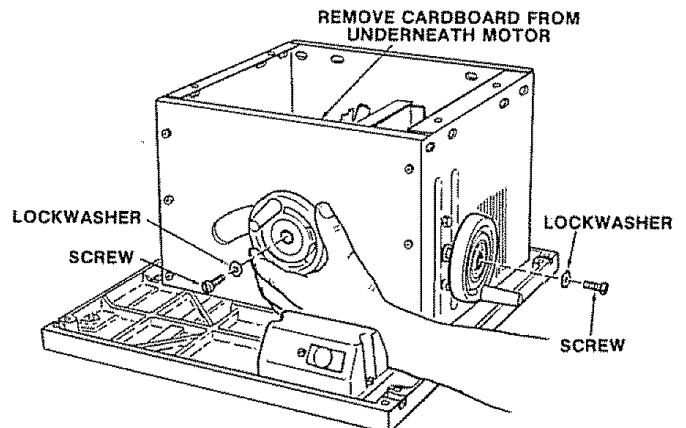

## ADJUSTING BLADE INSERT

1. Turn saw over.
2. Loosen Phillips screw in blade insert . . . do not remove.
3. Remove blade insert by lifting slightly and pulling insert toward front of saw to disengage from key hole slot.

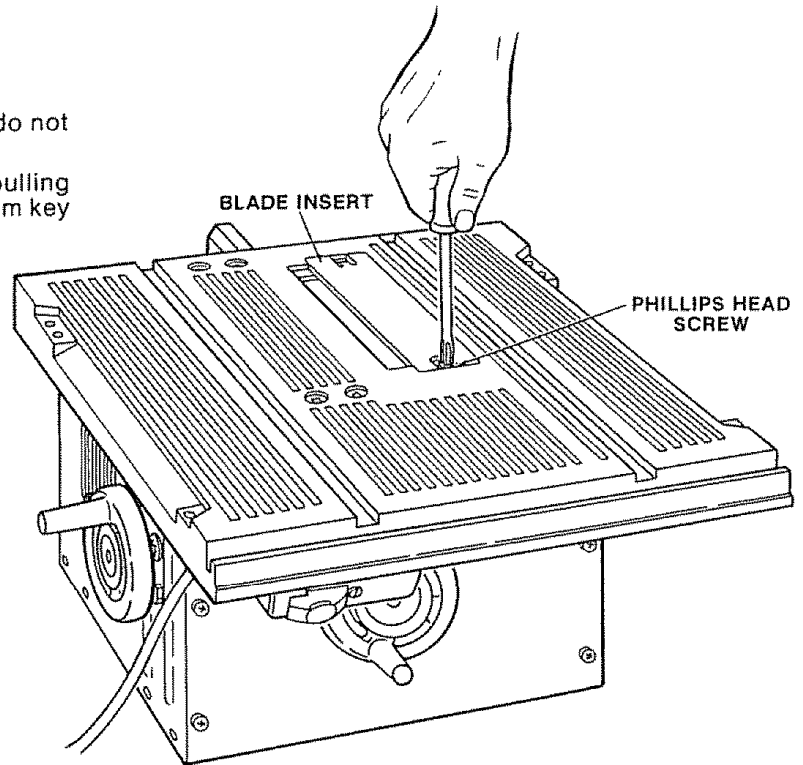

- 
4. Tab at rear of insert should engage in saw table firmly. It may be necessary to bend tab slightly using pliers.

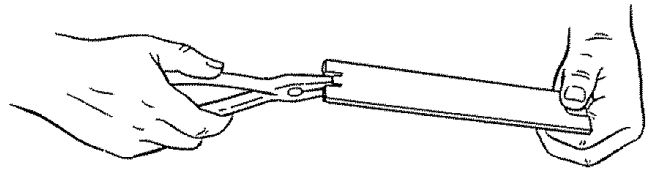

- 
5. Install blade insert by placing keyhole slot in insert over screw head in saw table and pushing insert to rear of saw table sliding tab in insert under saw table ledge.  
Tighten screw.

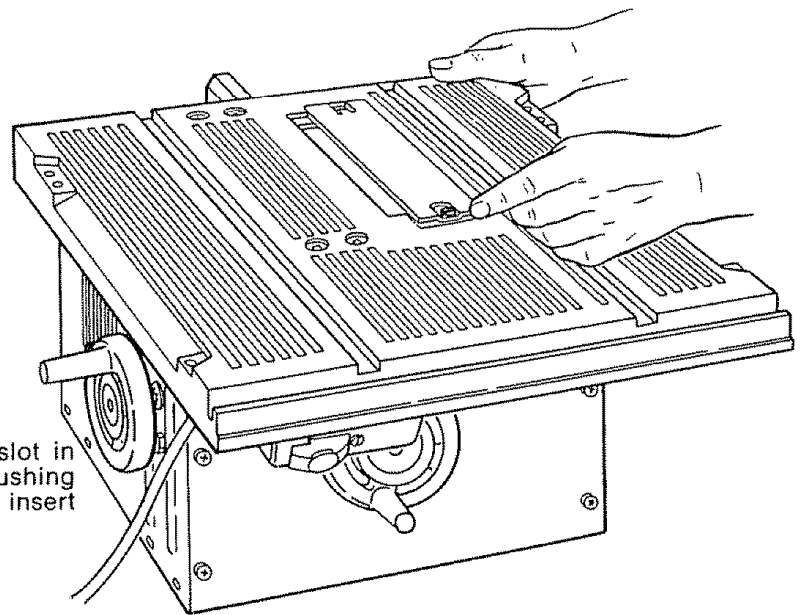

## CHECKING HEELING OR PARALLELISM OF SAW BLADE TO MITER GAUGE GROOVE

While cutting, the material must move in a straight line PARALLEL to the SAW BLADE . . . therefore both the miter gauge GROOVE and the RIP FENCE must be PARALLEL to the SAW BLADE.

If the saw blade is not parallel to the miter gauge groove, it is said to have "HEEL". This condition can cause the workpiece to bind or move workpiece away from the rip fence at the end of a cut, possibly causing a kickback.

**WARNING: TO AVOID INJURY FROM ACCIDENTAL START MAKE SURE SWITCH IS "OFF" AND PLUG IS NOT CONNECTED TO POWER SOURCE OUTLET.**

1. Elevate blade to maximum height by turning elevation handwheel.
2. Mark an "X" on one of the teeth which is SET (bent) to the LEFT.
3. Place the head of a combination square in the MITER GROOVE. Adjust blade of square so that it just touches the tip of the MARKED tooth.
4. Move square to REAR, rotate blade to see if MARKED tooth again touches blade of square.
5. If tooth touches square the same amount at FRONT and REAR, sawblade is PARALLEL to MITER GAUGE GROOVE.

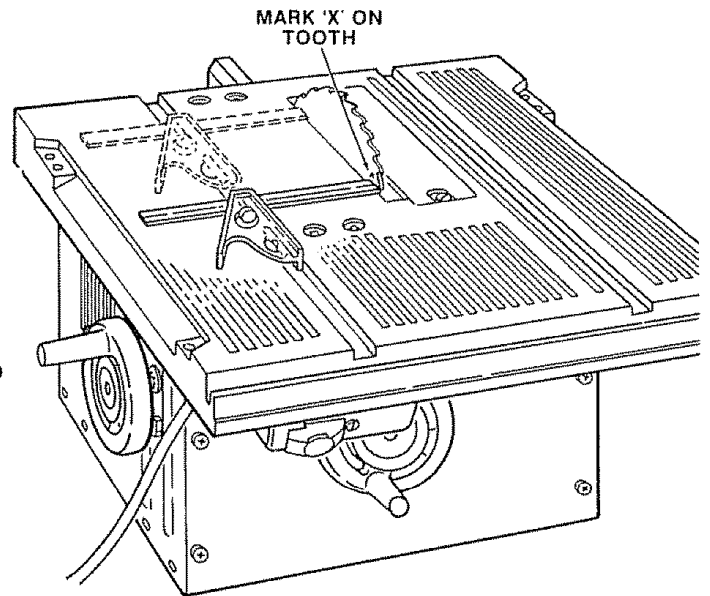

## ADJUSTING PARALLELISM OF SAW BLADE TO MITER GAUGE GROOVE

If tooth does not touch front and rear the mechanism underneath must be adjusted to make the blade PARALLEL to miter gauge groove.

1. Loosen the four hex socket screws in the top of the table next to the saw blade using a 3/16 inch hex L wrench. This will allow the mechanism below the table to be shifted sideways.

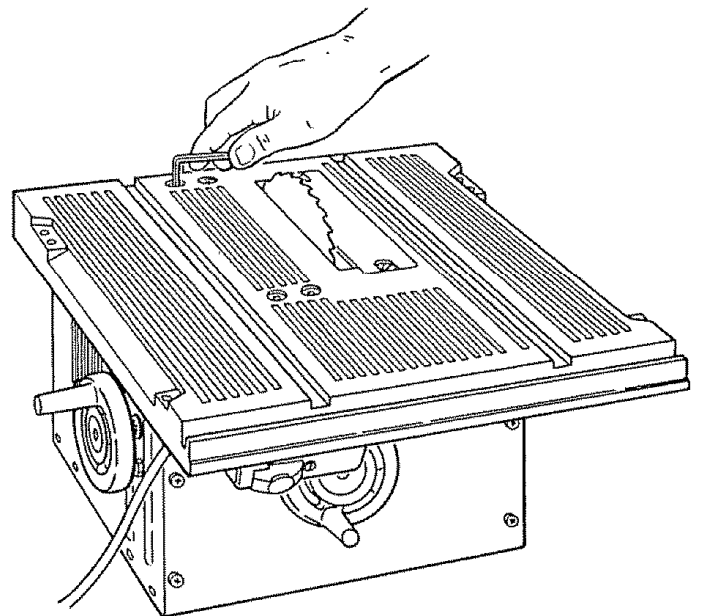

2. Fold a piece of cardboard or heavy paper over the blade to protect your hands
3. Grasp the blade and the cradle rod and move the mechanism right or left a small amount as needed to make the square touch the same amount front and rear. Tighten one screw.

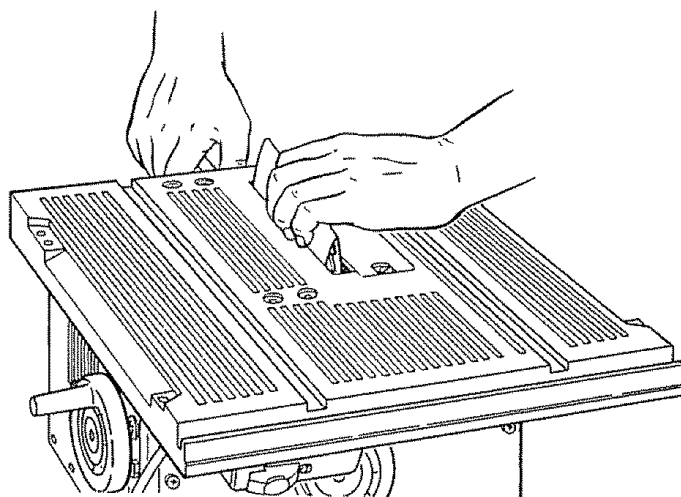

4. Check with square to determine if MARKED tooth touches square the same amount at front and rear

**If it does** — alternately tighten other three screws slowly

**If it does not** — loosen screw and move blade the required amount

5. Recheck blade clearance to table and table insert to make sure blade does not hit

**NOTE:** Use the hex L wrench as shown. Do not use a pair of pliers or any other tool to gain more leverage on the setscrew wrench.

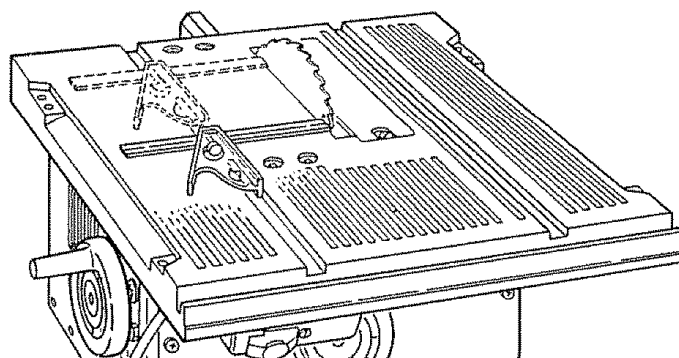

## ADJUSTING 90 DEGREE BEVEL STOP

(IMPORTANT: Blade must be square (90°) to table in order to accurately align the saw. Using care in the following adjustments will help assure accurate woodworking cuts.)

**WARNING: TO AVOID INJURY FROM ACCIDENTAL START, TURN SWITCH "OFF" AND REMOVE PLUG FROM POWER SOURCE OUTLET BEFORE ADJUSTING BEVEL STOP.**

1. Raise blade to highest elevation.
2. Turn bevel handwheel just until it stops under moderate pressure. Blade should be 90° to the table top.
3. Place a square flush on the table top to the left of the sawblade and slide the square up against the body of the sawblade, **NOT** against the teeth of the blade.
4. The square should be nearly flush with the body of the sawblade. When this is so, the sawblade is said to be 90° with respect to the table top. Notice the bevel pointer on the front of the saw. The pointer should be at 0°.
5. If you feel the blade is not close enough to 90° with respect to the table top, further adjustment can be made by performing the following operations.

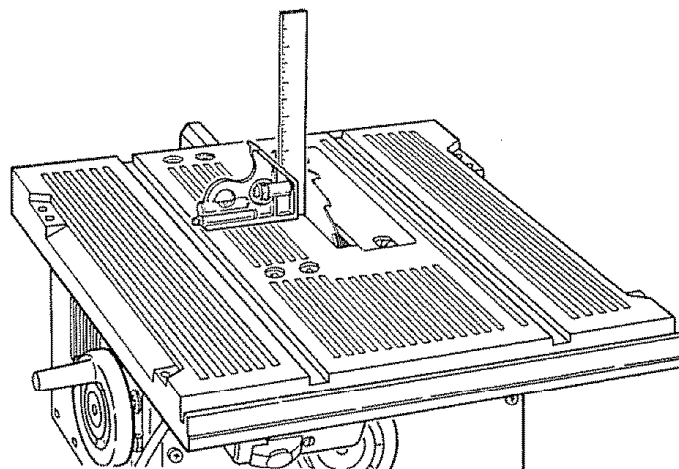

## ADJUSTING 90 DEGREE BEVEL STOP

1. On the stop bracket are two 10-32 pan head screws which set 90° stop position. If condition A exists the two screws need to be turned clockwise to obtain 90° setting. If condition B exists the screws should be turned counterclockwise.

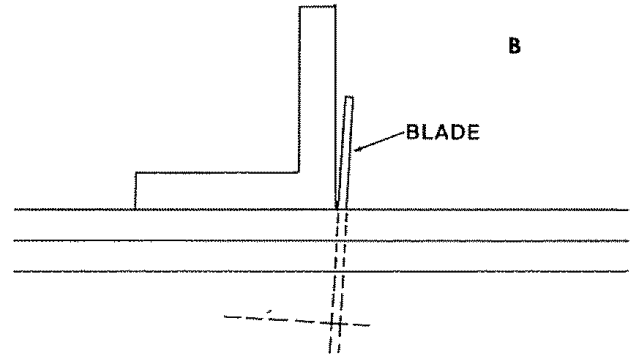
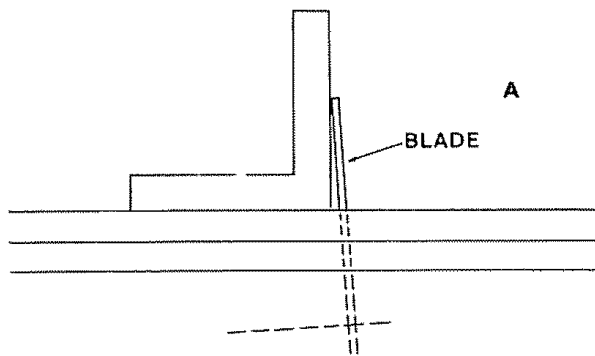

2. Turn saw over.
3. Rotate bevel crank blade is in approximately 40° position and using phillips screwdriver rotate screws slightly in direction necessary to correct gap, (rotate screws equally). Recheck blade position and readjust if necessary
4. When 90° stop position is adjusted to your satisfaction re-adjust pointer to 0° position.

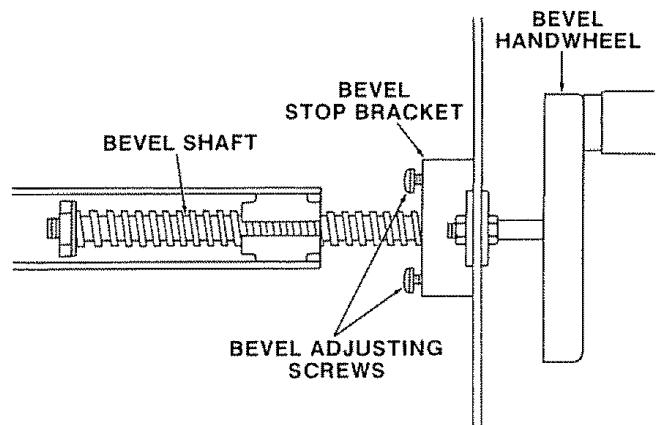

## ADJUSTING BEVEL POINTER

If blade IS SQUARE to table:

1. Check pointer.

If POINTER DOES NOT point to the "0" mark on the bevel scale:

2. Remove Elevation Handwheel.
3. Loosen screw and adjust pointer using medium screwdriver.
4. Install Elevation Handwheel.

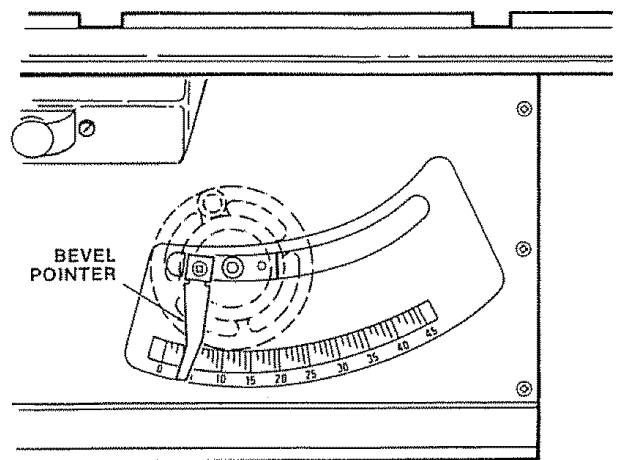

## CHECKING 45 DEGREE BEVEL STOP

- 1 Turn elevation handwheel clockwise to raise blade as high as it will go.
2. Turn bevel handwheel clockwise to tilt blade to 45°
3. Lay head of combination square on the blade of square as illustrated and place head against the blade. Make sure square is not touching TIP of one of the saw TEETH.
4. The 45° blade stop is set during manufacturing. If adjustment is needed proceed to next step. If bevel adjustment is satisfactory go on to installing table extensions.

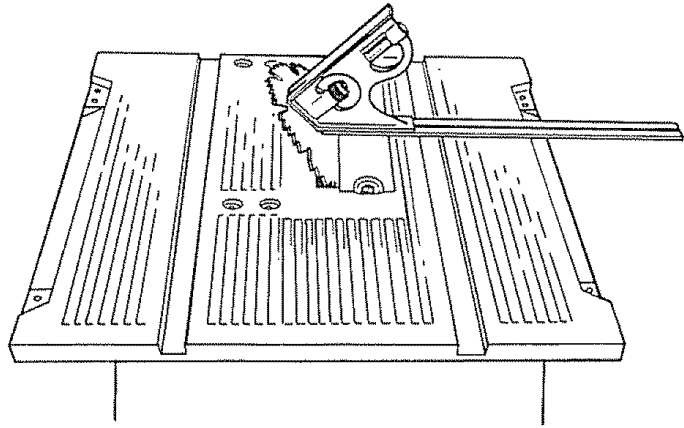

## ADJUSTING 45 DEGREE BEVEL STOP

1. The 45° blade position is controlled by the location of the sheet metal nut on end of bevel shaft.
2. If condition A exists the sheet metal nut needs to be turned clockwise (CW) to obtain 45° setting. If condition B exists the nut should be turned counterclockwise (CCW).
3. To correct condition A - Rotate bevel handle CCW approximately 2 turns, place 11/16 inch wrench on sheet metal nut and hold in place while rotating handle counterclockwise in small increments. Recheck blade position after each rotation.
4. To correct condition B - Same procedure as No. 3, except, rotate handle clockwise while holding nut.
5. Check blade clearance by rotating blade by hand making sure blade does not strike insert or table.

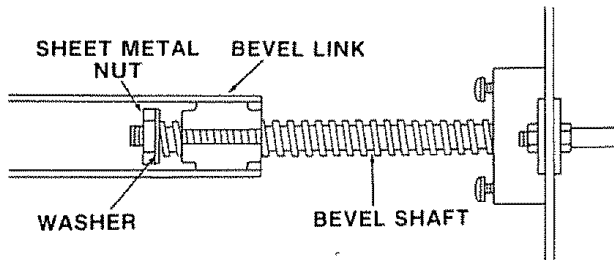
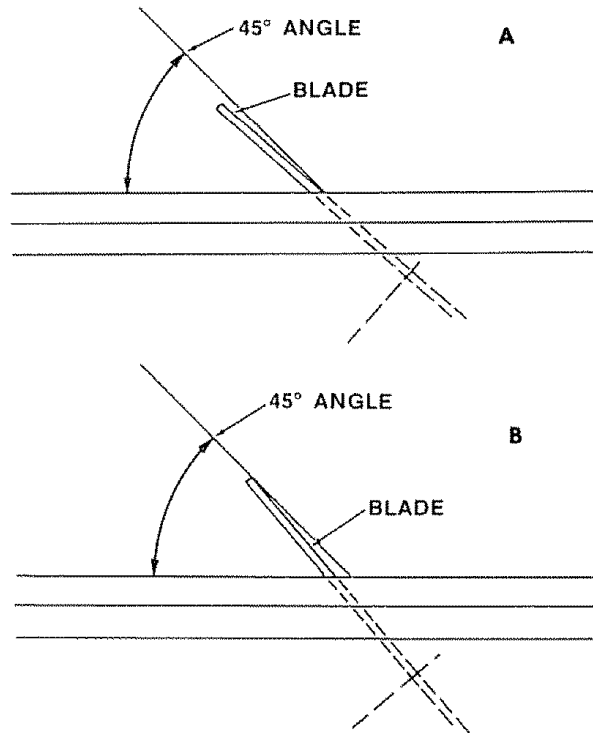

## INSTALLING TABLE EXTENSIONS

1. Among loose parts locate fourteen 1/4-20 x 5/8 inch long flat head hex socket screws.
2. Install right table extension and install seven screws using a 5/32 inch hex L wrench. Just start screws.
3. Install left table extension and install seven screws using a 5/32 inch hex L wrench. Just start screws.

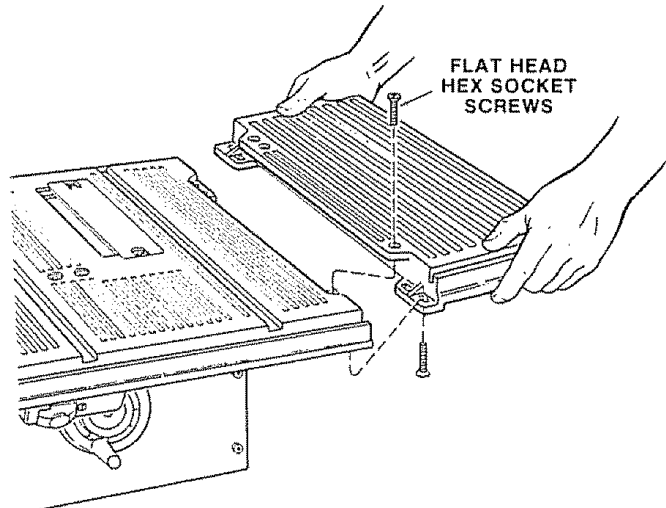

3. Install left table extension and install seven screws using 5/32 inch hex L wrench. Just start screws

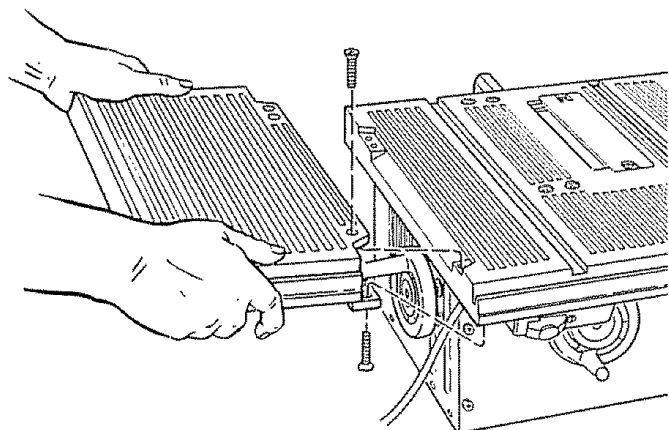

### ALIGNING TABLE EXTENSIONS

**NOTE:** The table extensions must be the same height as the table and level.  
Place combination square on table and extension.

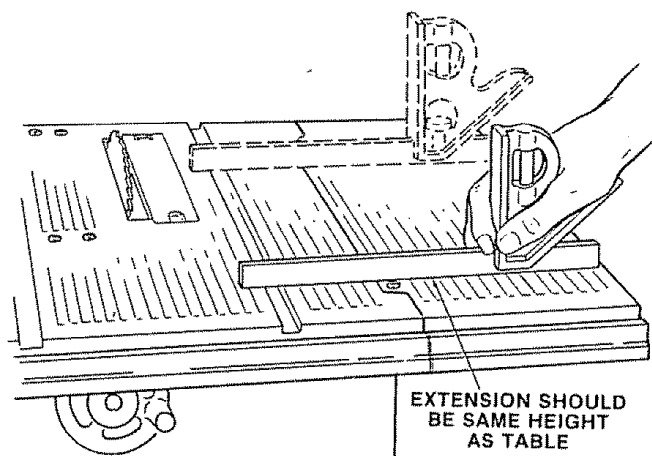

### TO RAISE EXTENSION

1. If extension is low loosen three screws on top of the table extension A, B, and C. See illustration.
2. Tighten screws D, E, F, and G underneath table extension to raise extension even with table top front and rear.
3. Check height with square and tighten A, B and C.
4. Repeat for left extension

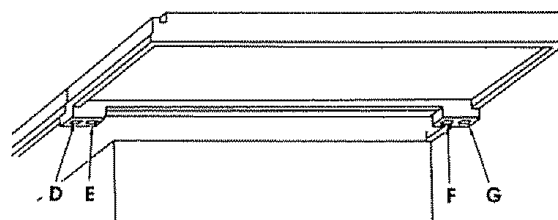
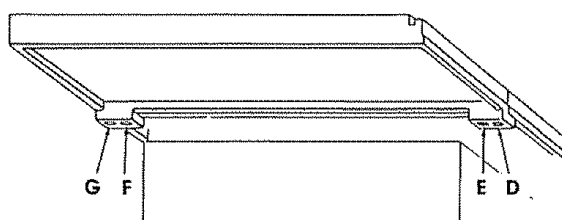
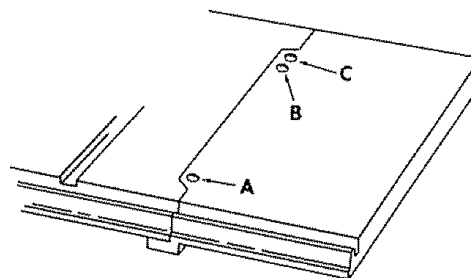
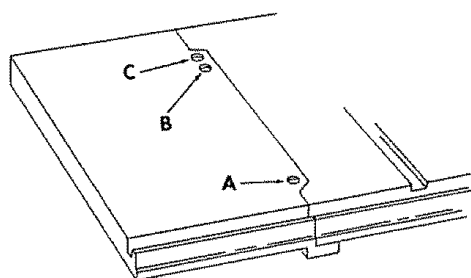
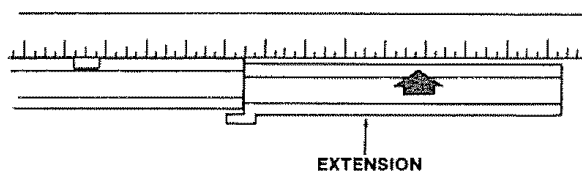

## TO LOWER EXTENSION

1. If extension is too high loosen four screws on underside of the extension D, E, F, and G. See illustration.
2. Tighten screws A, B and C on top of table extension to lower extension even with table top front and rear.
3. Check height with square and tighten screws D, E, F and G.
4. Repeat for left extension.

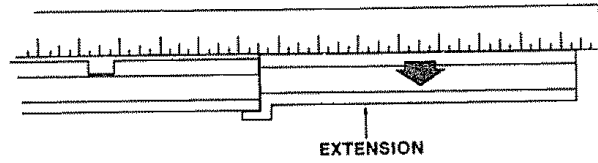

## LEVELING EXTENSIONS

Place combination square on table and extension so that end of blade extends over edge of extension. Hold square firmly on saw table and check for gap between extension and blade of square.

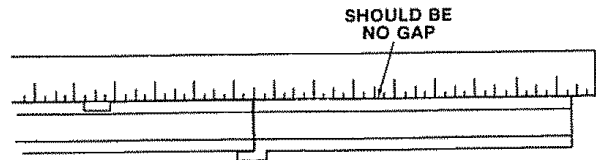

## TO LOWER OUTER EDGE OF EXTENSION

1. Loosen screws B, E, and F on right extension. See illustration.
2. Tighten screws C, D, and G until table extension is level.
3. Snug down screws B, E, and F.
4. Repeat for left extension.

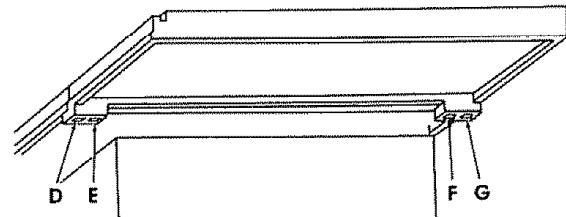
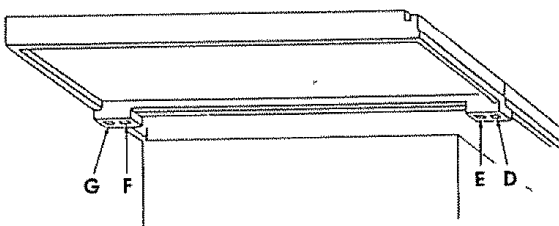
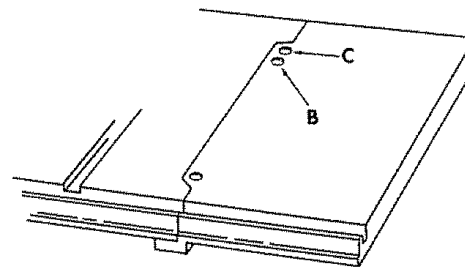
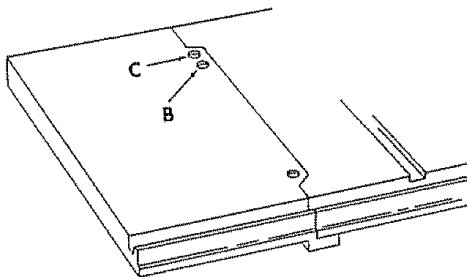
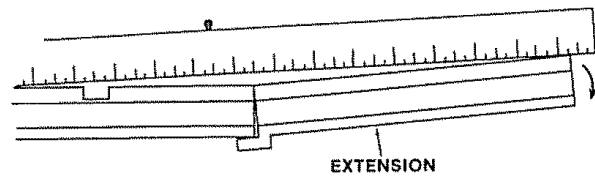

## TO RAISE OUTER EDGE OF EXTENSION

1. Loosen screws C, D, and G on right extension.
2. Tighten screws B, E, and F until table extension is level.
3. Snug down screws C, D, and G.
4. Repeat for left table extension.

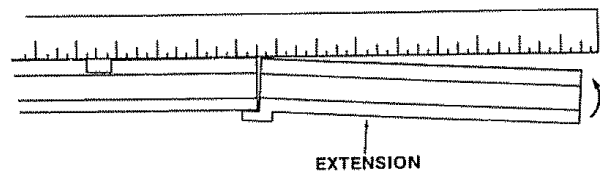

## ALIGNING TABLE EXTENSIONS WITH FRONT OF TABLE

1. Place blade of combination square on front of table and table extension.
2. Extension should line up with table.

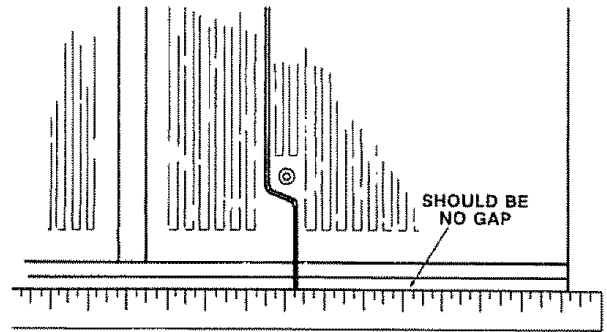

## TO MOVE OUTER EDGE OF EXTENSION BACK

1. Loosen screws C and F in right extension. See illustration.
2. Tighten screws B and G until extension is lined up.
3. Snug down screws C and F.
4. Recheck level and flatness to table.
5. Check left extension.
6. Adjust left extension in same manner.

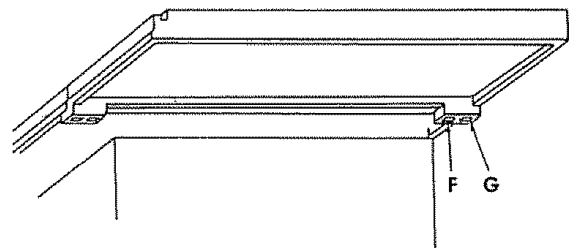
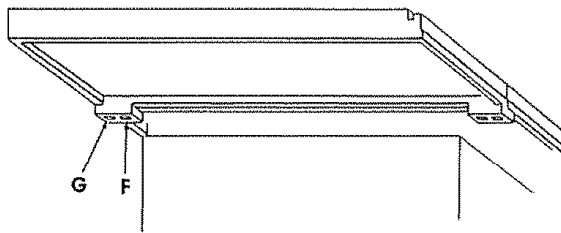
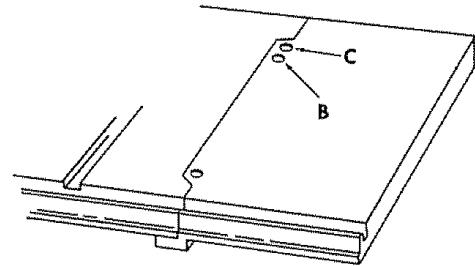
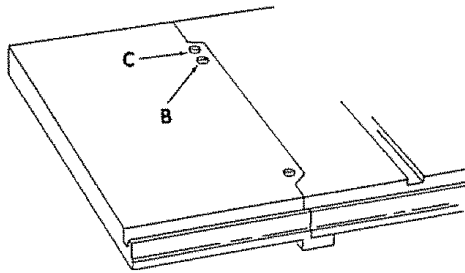
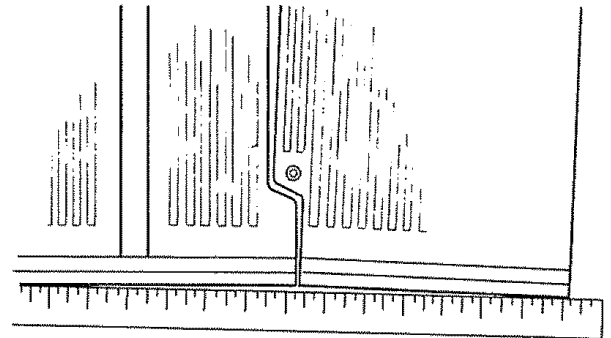

## TO MOVE OUTER EDGE OF EXTENSION FORWARD

1. Loosen screws B and G in right extension.
2. Tighten screws C and F until extension is lined up.
3. Snug down screws B and G.
4. Recheck level and flatness to table. Check left extension.
4. Recheck level and flatness to table
5. Check left extension.
6. Adjust left extension in same manner.

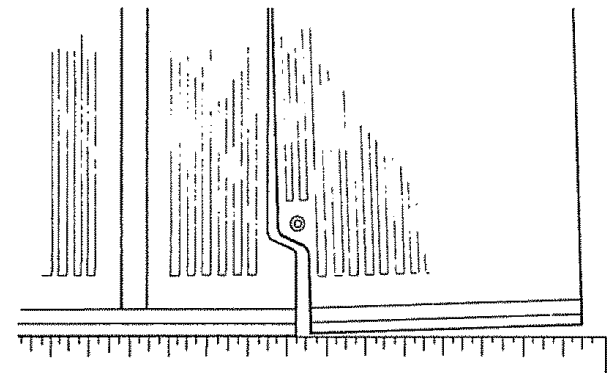

## INSTALLING BLADE GUARD

1. From among the loose parts, find the hardware as shown.

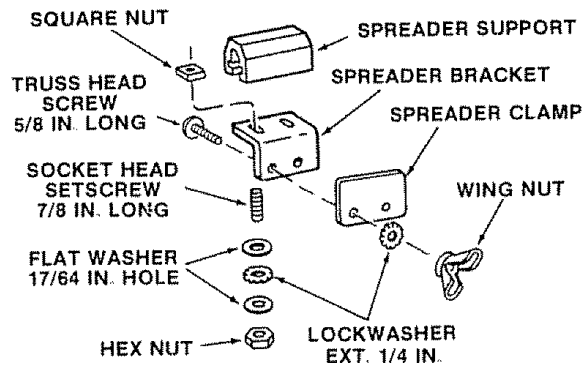

2. MAKE SURE THE BLADE IS ALL THE WAY UP AND SQUARE WITH THE TABLE
3. Position SPREADER SUPPORT on rod until it is even with the end of the rod

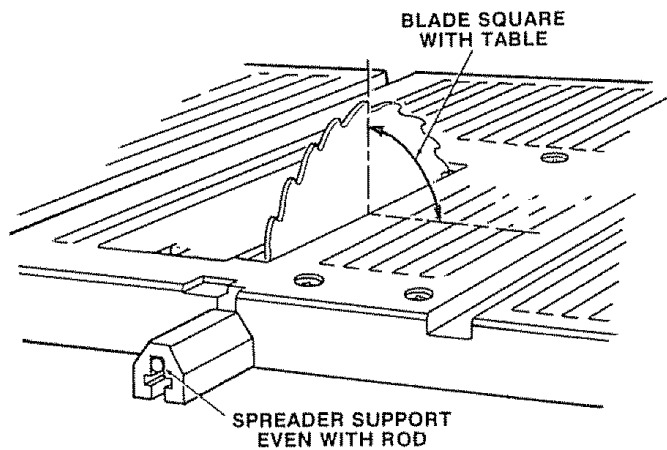

4. Assemble the 7/8 in. long setscrews, nuts, lockwashers and washers to the SPREADER SUPPORT BRACKET and slip the nuts into the slot in the spreader support
5. Finger tighten ONLY THE HEX NUTS.

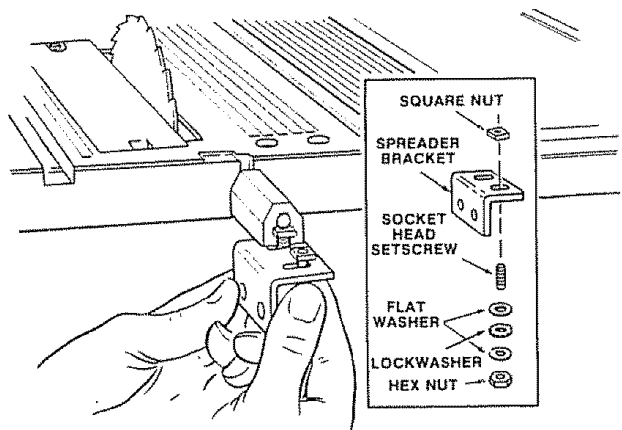

6. Lay a piece of flat straight wood and a square on saw table and rotate the SPREADER SUPPORT until the bracket is aligned with square.
7. MAKE SURE END OF SUPPORT, BRACKET AND ROD ARE EVEN . . . using an 1/8 in. Hex L wrench, TIGHTEN THE SET SCREWS ONLY.

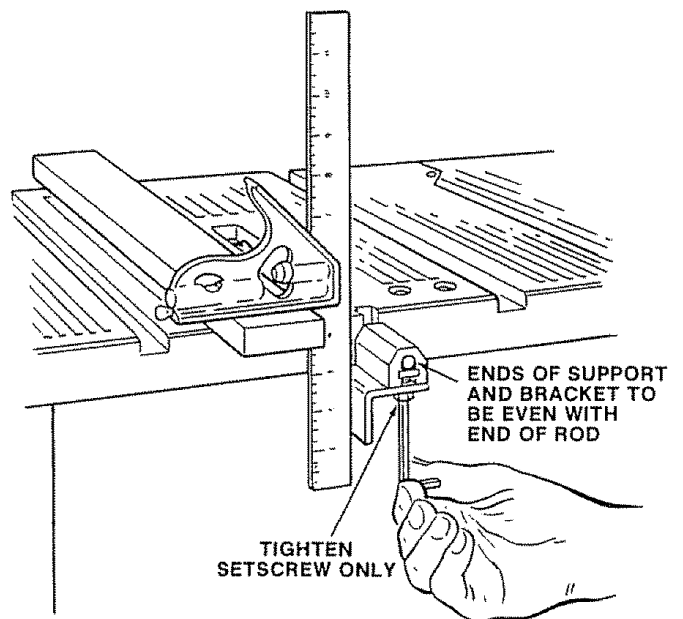

### ALIGNING SPREADER

**IMPORTANT:** The SPREADER must always be PARALLEL to the sawblade and in the MIDDLE of the cut (KERF) made by the sawblade.

**NOTE:** The spreader is thinner than the width of the KERF by approximately six thicknesses of paper.

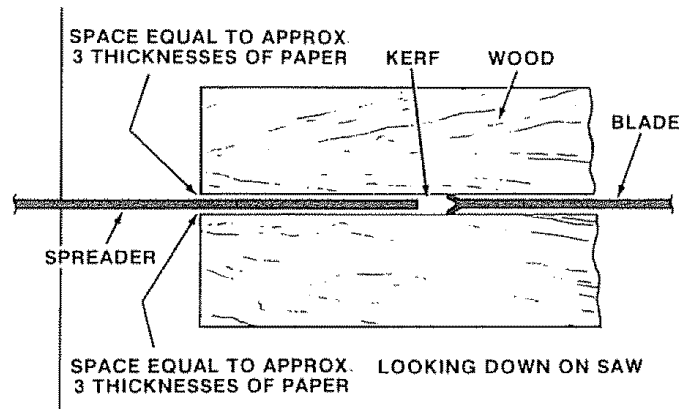

1. Make two folds in a small piece (6 x 6 in.) of ordinary NEWSPAPER making three thicknesses. The folded paper will be used as a "spacing gauge".

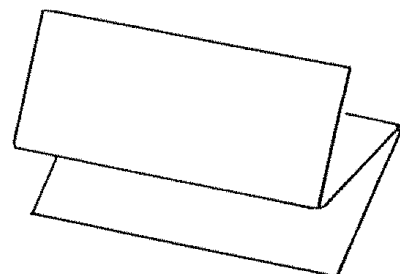

2. Install the SPREADER CLAMP. Place spreader between spreader clamp and bracket. Move forward until all three are in line. TIGHTEN WING NUTS.
3. Lay a piece of straight flat wood against the sawblade. Insert folded paper between spreader and strip of wood.
4. MAKE SURE THE HEX NUTS UNDERNEATH ARE LOOSE.
5. Lift the antikickback pawl to clear the wood and hold the spreader tightly against the wood. Make sure the wood is against the saw blade. TIGHTEN THE HEX NUTS.

This will align the spreader in the middle of the cut (KERF) made by sawblade.

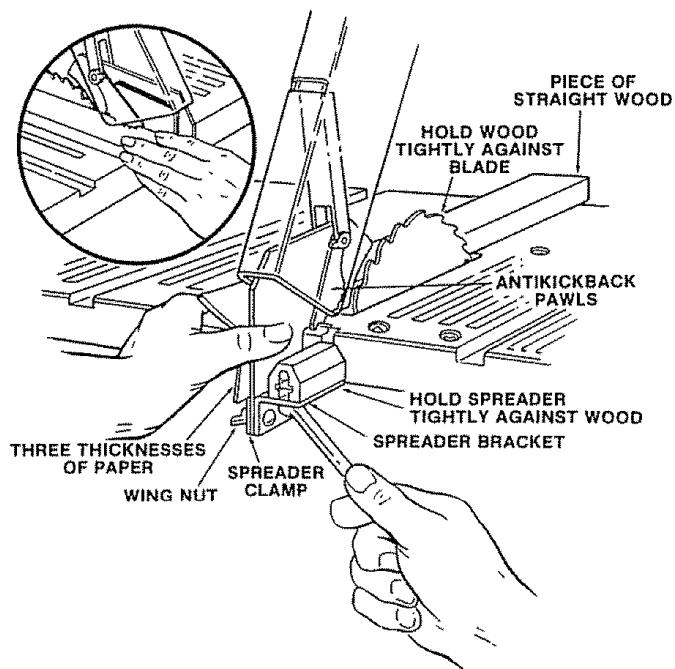

## ATTACHING RIP FENCE

Apply a coat of paste wax to the top surface and front ledge of the saw table. This will allow the fence to slide more easily.

1. Loosen fence lock knob by turning counter-clockwise.
2. Attach fence head by placing head of fence over front ledge in saw table.

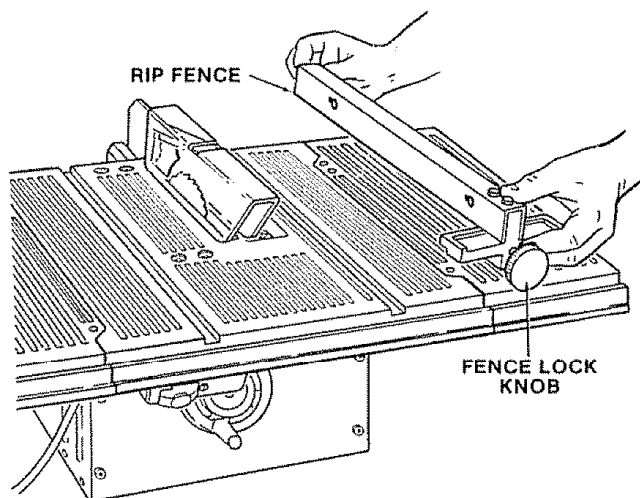

## ALIGNING RIP FENCE

**IMPORTANT:** The rip fence **MUST** be parallel with saw blade and miter grooves in order to help prevent **KICKBACK** of the workpiece when ripping. Careful adjustment is required.

1. Hold head of rip fence and slide on table until the edge of the fence lines up with the right miter slot.
2. Turn fence lock knob clockwise to lock fence.
3. If fence does not line up with miter slot front and rear:
  - A. Loosen the two hex screws in top of fence.
  - B. While holding head of rip fence, move rear of rip fence right or left until edge lines up with miter slot.
  - C. Tighten hex screws alternately being careful not to move fence.

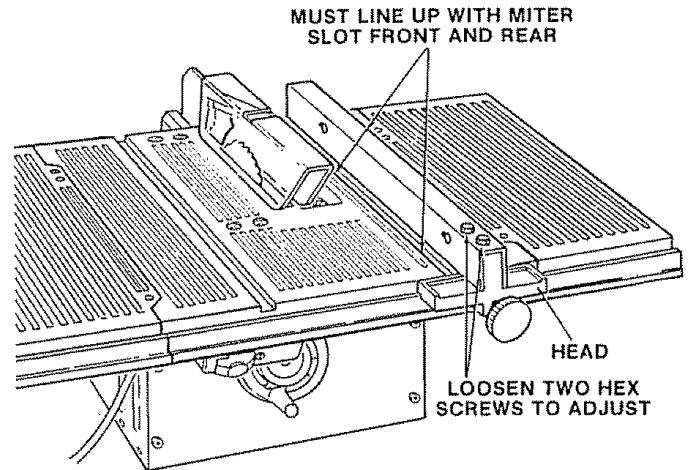

## ADJUSTING MITER GAUGE

**NOTE:** The graduations are manufactured to very close tolerances which provide suitable accuracy for average woodworking. In some cases where extreme accuracy is required, when making angle cuts, for example, make a trial cut and then recheck it.

If necessary, the miter gauge head can then be swiveled slightly to compensate and then locked. The HEAD should be SQUARE (90°) with the bar when the pointer points to "0".

To check for squareness, place an accurate square on the miter gauge. If the head is NOT SQUARE with the bar:

1. Loosen the lock handle.
2. Position the head square with the bar ... tighten the handle.
3. Loosen the screw and adjust the pointer, so it points to zero.

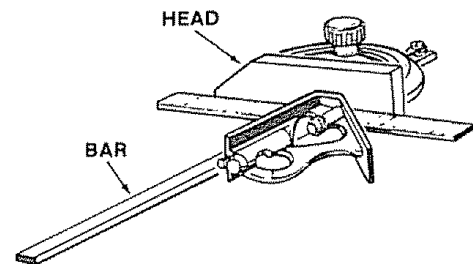

## MOUNTING SAW TO LEGS OR BENCH

If you purchase Craftsman Steel Legs for your saw, assemble them according to the directions furnished with them.

If you mount the saw on any other bench, make sure that there is an opening in the top of the bench the same size as the opening in the bottom of the saw so that the sawdust can drop through. Recommended working height is 33 to 37 in. from the top of the saw table to the floor.

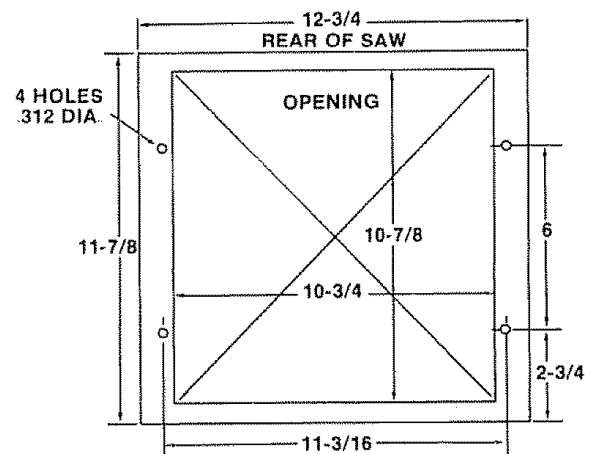

NOTE: All dimensions in inches.

# GETTING TO KNOW YOUR SAW

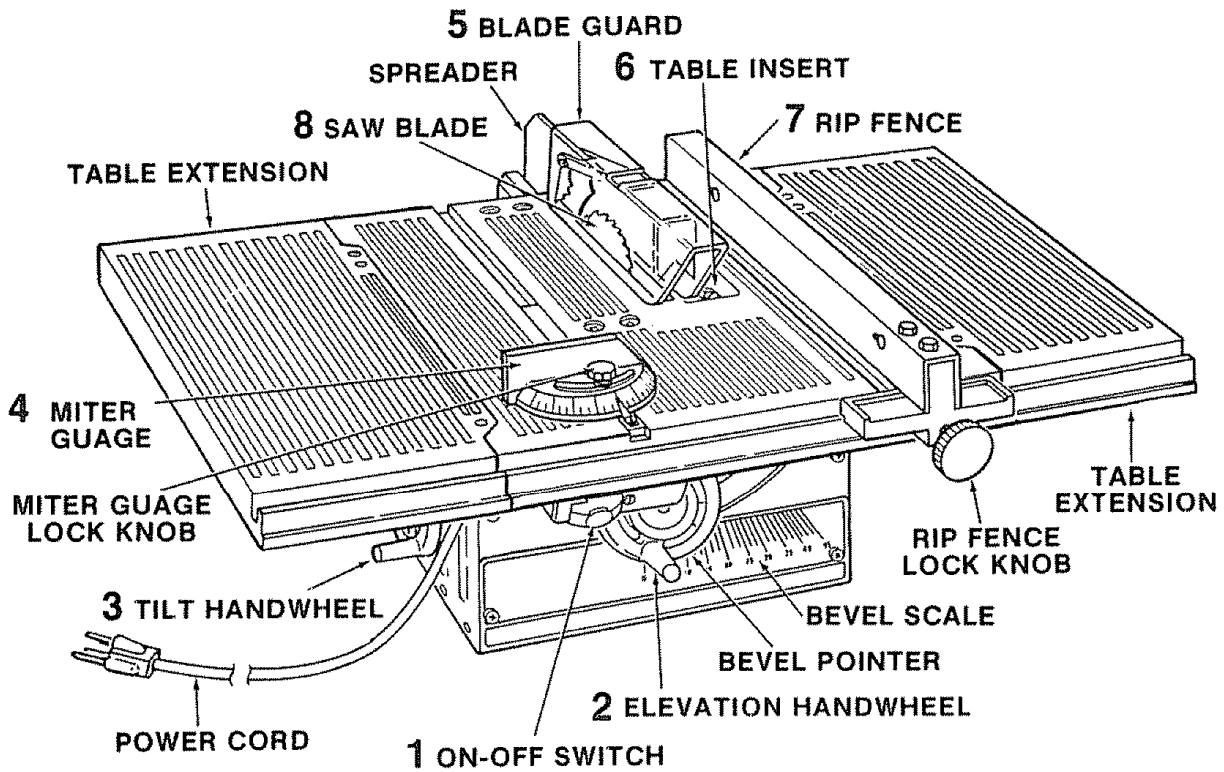

## 1. ON-OFF SWITCH

**CAUTION:** Before turning switch on, make sure the blade guard is correctly installed and operating properly.

The On-Off Switch has a locking feature. THIS FEATURE IS INTENDED TO HELP PREVENT UNAUTHORIZED AND POSSIBLE HAZARDOUS USE BY CHILDREN AND OTHERS.

A. Insert Key into switch.

B. TO turn saw ON . . . stand to either side of the blade never in line with it . . . insert finger under switch lever and pull END of lever out.

After turning switch ON, always allow the blade to come up to full speed before cutting.

Do not cycle the motor switch on and off rapidly, as this may cause the sawblade to loosen. In the event this should ever occur, allow the sawblade to come to a complete stop and retighten the arbor nut normally, not excessively. Never leave the saw while the power is "ON"

C TO turn saw OFF . . . PUSH lever in. Never leave the saw until the cutting tool has come to a complete stop.

D To lock switch in OFF position . . . hold switch IN with one hand . . . REMOVE key with other hand.

**WARNING:** FOR YOUR OWN SAFETY, LOWER BLADE OR OTHER CUTTING TOOL BELOW TABLE SURFACE. (IF BLADE IS TILTED, RETURN IT TO VERTICAL (90°) POSITION). ALWAYS LOCK THE SWITCH

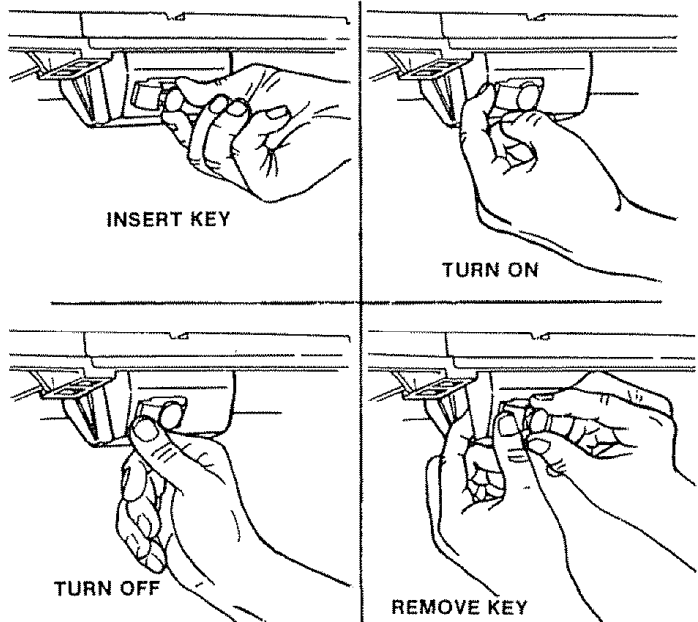

"OFF". WHEN SAW IS NOT IN USE . . . REMOVE KEY AND KEEP IT IN A SAFE PLACE . . . ALSO . . . IN THE EVENT OF A POWER FAILURE (ALL OF YOUR LIGHTS GO OUT) TURN SWITCH OFF . . . LOCK IT AND REMOVE THE KEY. THIS WILL PREVENT THE SAW FROM STARTING UP AGAIN WHEN THE POWER COMES BACK ON.

2. **ELEVATION HANDWHEEL** ... elevates or lowers the blade. Turn counterclockwise to elevate ... clockwise to lower

3. **TILT HANDWHEEL** ... tilts the blade for bevel cutting. Turn counterclockwise to tilt toward left ... clockwise to tilt toward right

When the blade is tilted to the LEFT as far as it will go, it should be at 45° to the table and the bevel pointer should point 45°.

**NOTE:** There are LIMIT STOPS inside the saw which prevent the blade from tilting beyond 45° to the LEFT and 90° to the RIGHT. (See "Adjustments" section "Blade Tilt, or Squareness of Blade to Table")

4. **MITER GAUGE** ... head is locked in position for crosscutting or mitering by tightening the lock knob. ALWAYS LOCK IT SECURELY WHEN IN USE

5. **BLADEGUARD** must always be in place and working properly for all thru-sawing cuts. That is, all cuts whereby the blade cuts completely through the workpiece.

To remove the guard for special operation, loosen both wing nuts, slide spreader back and up. DO NOT DISTURB THE SETTING OF THE SPREADER SUPPORT BRACKET.

When replacing the guard, insert spreader between bracket and clamp and slide forward. TIGHTEN BOTH WINGNUTS SECURELY.

6. **TABLE INSERT** is removable for removing or installing blades or other cutting tools

**WARNING: FOR YOUR OWN SAFETY, TURN SWITCH "OFF" AND REMOVE PLUG FROM POWER SOURCE OUTLET BEFORE REMOVING INSERT.**

A. Lower the blade below the table surface

B. Raise blade guard

C. Loosen Screw (Do Not Remove)

D. Lift insert from front end, and pull toward front of saw.

NEVER OPERATE THE SAW WITHOUT THE PROPER INSERT IN PLACE. USE THE SAW BLADE INSERT WHEN SAWING ... USE THE MOLDING INSERT WHEN MOLDING

7. **RIP FENCE** ... is locked in place by tightening the lock knob. To move the fence, loosen the knob and grasp the fence with one hand at the front.

Holes are provided in the rip fence for attaching a wood facing when using the dado head, or molding head

Select a piece of smooth straight wood approx. 3/4" thick, at least as long as the rip fence, and at least 7-1/2" wide (high) to permit clamping of featherboards.

Attach it to the fence with two Round Head #10 Wood Screws 2 in. long. To remove the facing, loosen the screws, slide the facing forward and pull the screws through the round holes

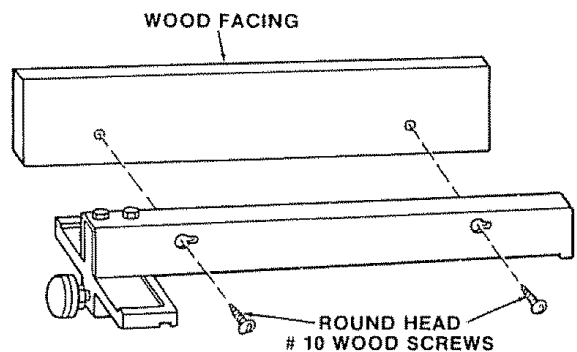

**CAUTION:** When positioning fence for maximum rip, make sure end of fence HEAD is even with edge of table extension. Fence cannot be locked securely beyond the edge of the table extension.

## REMOVING AND INSTALLING SAWBLADE

**WARNING: TO AVOID INJURY FROM ACCIDENTAL START, TURN SWITCH "OFF" AND REMOVE PLUG FROM POWER SOURCE OUTLET BEFORE REMOVING OR INSTALLING SAWBLADE.**

**NOTE:** When installing the blade ... make sure the upper saw teeth are pointing toward the front of the saw ... and that the blade and collars are clean, and free from any burrs

The HOLLOW side of the collars must be against the blade.

**NOTE:** Always place the LARGE collar on the shaft before the blade.

**NOTE:** Do not overtighten arbor nut. Use the arbor wrench to just "snug" it

1. Loosen Phillips head screw in blade insert ... Do not remove

2. Remove blade insert by lifting slightly and pulling insert to disengage from key hole slot.

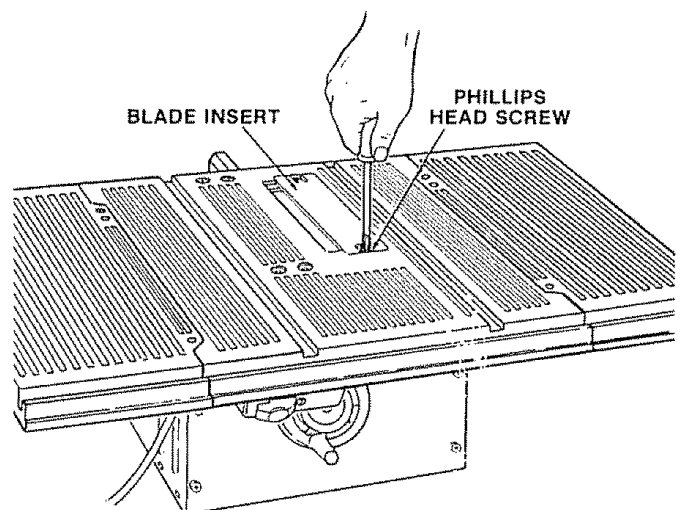

3. Turn elevation handwheel clockwise to raise motor shaft as high as it will go.
4. Insert shaft wrench over flat portions of motor spacer and arbor wrench over arbor nut.
5. Hold shaft wrench and loosen arbor nut with arbor wrench.

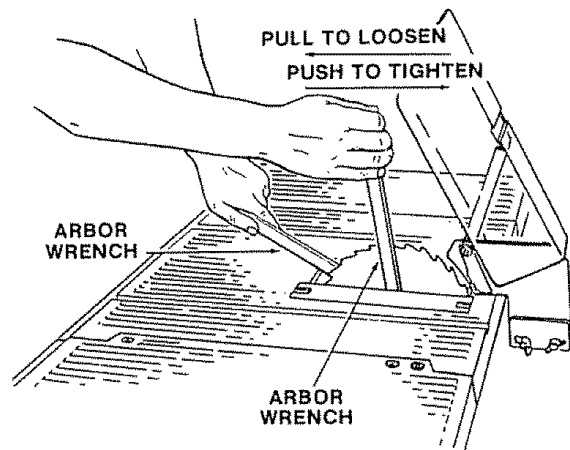

## TO INSTALL SAWBLADE

1. Install large inner blade collar onto motor shaft with rounded surface toward motor.
2. Install saw blade onto shaft with top teeth pointing toward front of saw.
3. Install small outer blade collar with flat surface toward blade.
4. Install arbor nut. Note: Arbor nut should just be snug. Do not overtighten.

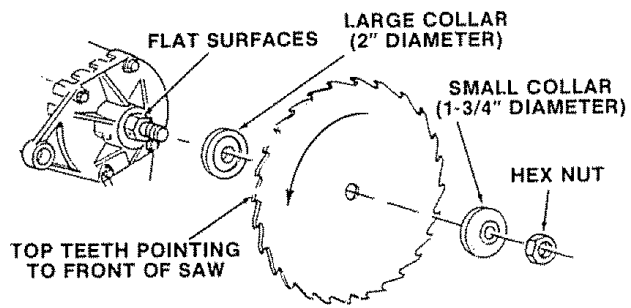

**IMPORTANT: Do not attempt to run saw without both blade collars properly installed.**

5. Install blade insert by placing keyhole slot in insert over screw head in saw table and pushing insert to rear of saw table engaging tab in insert onto saw table ledge.

Tighten screw.

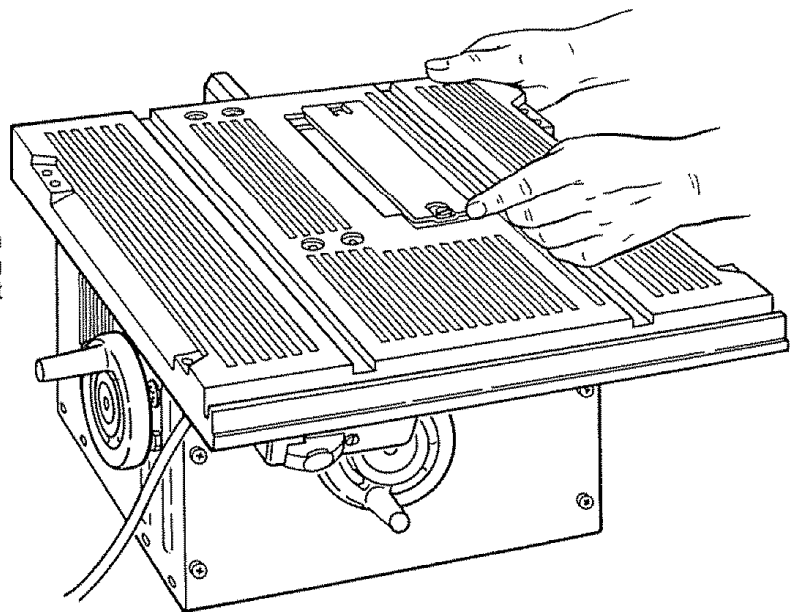

# BASIC SAW OPERATION

## USING THE MITER GAUGE

**CROSSCUTTING, MITER CUTTING, BEVEL CUTTING, COMPOUND MITER CUTTING** and when **RABBETING** across the end of a narrow workpiece, the **MITER GAUGE** is used.

**WARNING: FOR YOUR OWN SAFETY, ALWAYS OBSERVE THE FOLLOWING SAFETY PRECAUTIONS IN ADDITION TO THE SAFETY INSTRUCTIONS ON PAGES 2, 3, and 4.**

1. Never make these cuts freehand (without using the miter gauge or other auxiliary devices) because the blade could bind in the cut and cause a **KICKBACK** or cause your fingers or hand to slip into the blade.
2. Always lock the miter gauge securely when in use.
3. Remove rip fence from table.
4. Make sure blade guard is installed for all "thru-sawing" operations (when sawblade cuts entirely thru the thickness of the workpiece.) Replace guard **IMMEDIATELY** after completion of dadoing, molding or rabbeting cuts.
5. Have blade extend approximately 1/8 in. above top of workpiece. Additional blade exposure would increase the hazard potential.
6. Do not stand directly in front of the blade in case of a **THROWBACK** (Small cut-off piece caught by the back of the blade and thrown toward the operator). Stand to either side of the blade.
7. Keep your hands clear of the blade and out of the path of the blade.
8. If blade stalls or stops while cutting, **TURN SWITCH OFF** before attempting to free the blade.
9. Do not reach over or behind the blade to pull the workpiece through the cut . . . to support long or heavy workpieces . . . to remove cut-off pieces of material or **FOR ANY OTHER REASON**.
10. Do not pick up small pieces of cut-off material from the table. **REMOVE** them by pushing them **OFF** the table with a long stick. Otherwise they could be thrown back at you by the rear of the blade.
11. Do not remove small pieces of cut-off material that may become **TRAPPED** inside the blade guard while the saw is **RUNNING**. **THIS COULD ENDANGER YOUR HANDS** or cause a **KICKBACK**.  
Turn the saw **OFF**. After the blade has stopped turning, lift the guard and remove the piece.
12. If workpiece is warped, place the **CONCAVE** side **DOWN**. This will prevent it from rocking while it is being cut.

## WORK HELPERS

Before cutting any wood on your saw, study all of the "Basic Saw Operations".

Notice that in order to make some of the cuts, it is necessary to use certain devices "Work Helpers" like the Push Stick, the Push Block and the Auxiliary Fence, which you can make yourself.

After you have made a few practice cuts, make up these "helpers" before starting any projects. Make the "Push Stick" first. To rip the piece for the push stick, start out with a wide board, say 11-1/2 in. wide and set the rip fence 9-3/4 in. from the blade.

### PUSH STICK AND PUSH BLOCK

Make the Push Stick using a piece of 1 x 2.

Make the Push Block using a piece of 3/8 in. and 3/4 in. plywood.

The small piece of wood 3/8 in. x 3/8 in. x 2-1/2 in. should be **GLUED** to the plywood . . . **DO NOT USE NAILS**. This is to prevent dulling the sawblade in the event you mistakingly cut into the push block.

Position the handle in the center of the plywood and fasten together with glue and woodscrews.

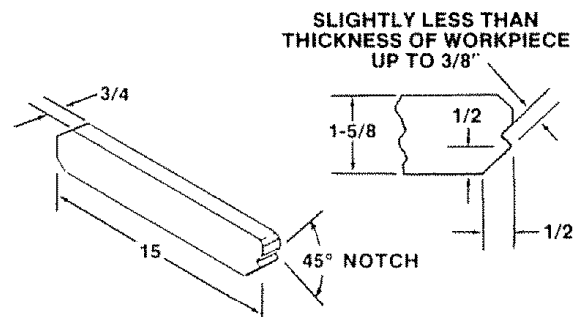

NOTE: All dimensions in inches

PUSH STICK

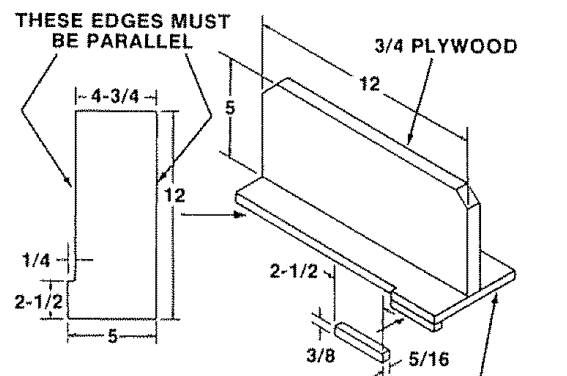

NOTE: All dimensions in inches 3/8 PLYWOOD

## AUXILIARY FENCE

Make one using a piece of 3/8 in. and 3/4 in. plywood. Fasten together with glue and woodscrews.

**NOTE:** Since the Push Block is used with the Auxiliary Fence, the 4-3/4 in. dimensions must be held identical on both the pieces.

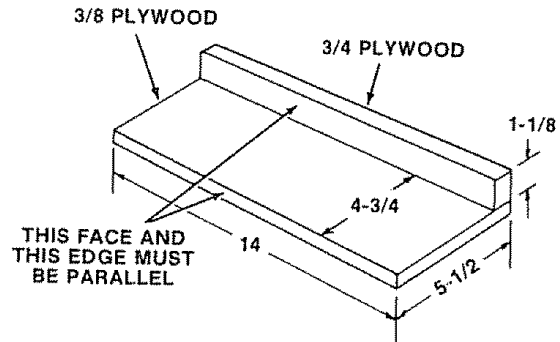

NOTE: All dimensions in inches.

AUXILIARY FENCE

## CROSSCUTTING

CROSSCUTTING is cutting wood across the grain, at 90°, or square with both the edge and the flat side of the wood. This is done with the miter gauge and blade angle set at "0". The graduations on the miter gauge provide accuracy for average woodworking. In some cases where extreme accuracy is required, when making angle cuts, for example, make a trial cut and then recheck it with an accurate square, or protractor.

If necessary, the miter gauge head can be swiveled slightly to compensate for any inaccuracy.

**NOTE:** The space between the miter gauge bar and the groove in the table is held to a minimum during manufacturing.

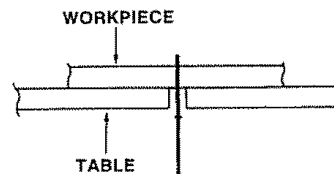

For maximum accuracy when using the miter gauge, always "favor" one side of the groove in the table. In other words, don't move the miter gauge from side to side while cutting, but keep one side of the bar riding against one side of the groove.

**NOTE:** Glue a piece of sandpaper to the face of the miter gauge head. This will help prevent the workpiece from "creeping" while it is being cut.

The miter gauge may be used in either of the grooves in the table. Make sure locking knob is tight.

When using the miter gauge in the LEFT hand groove, hold the workpiece firmly against the miter gauge head with your left hand, and grip the lock knob with your right.

When using the RIGHT hand groove, hold the workpiece with your right hand and the lock knob with your left hand.

When cutting long workpieces, make sure the end is supported from the floor.

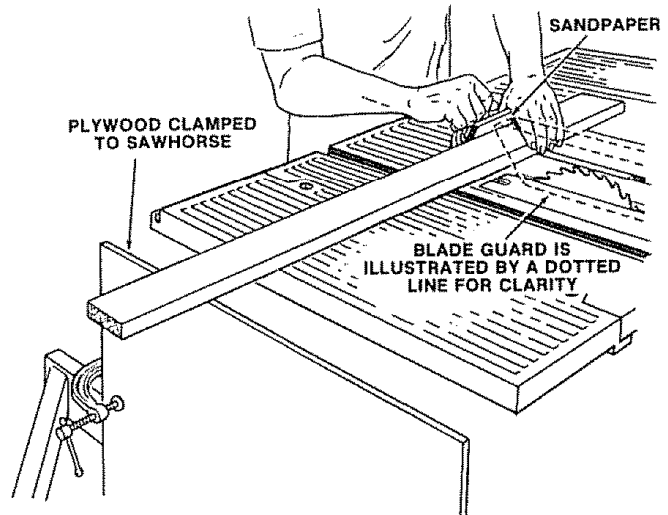

## REPETITIVE CUTTING

REPETITIVE CUTTING is cutting a quantity of pieces the same length without having to mark each piece.

**NOTE:** When making repetitive cuts from a long workpiece make sure it is supported.

1. NEVER USE THE RIP FENCE AS A LENGTH STOP BECAUSE THE CUTOFF PIECE COULD BIND BETWEEN THE FENCE AND THE BLADE CAUSING A KICKBACK

2. When making repetitive cuts shorter than 6 in., clamp a block of wood 3 in. long to the table to act as a length stop

**CAUTION:** When clamping the block, make sure that the end of the block is well in front of the sawblade. Be sure it is clamped securely.

3. Slide the workpiece along the miter gauge until it touches the block . . . hold it securely.

4. Make the cut . . . pull the workpiece back . . . push the cut off piece off the table with a long push stick . . . DO NOT ATTEMPT TO PICK IT UP AS THIS COULD ENDANGER YOUR HANDS.

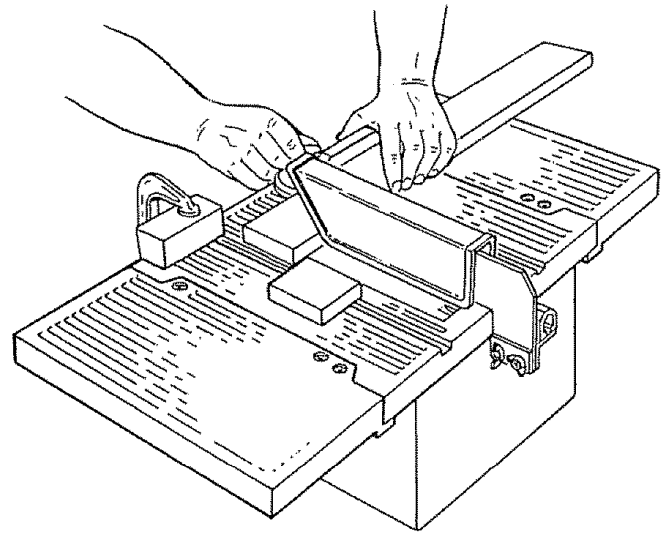

## MITER CUTTING

MITER CUTTING is cutting wood at an angle other than 90° with the edge of the wood. Follow the same procedure as you would for crosscutting.

Adjust the miter gauge to the desired angle, and lock it.

The miter gauge may be used in either of the grooves in the table.

When using the miter gauge in the LEFT hand groove, hold the workpiece firmly against the miter gauge head with your left hand, and grip the lock knob with your right.

When using the RIGHT hand groove, hold the workpiece with your right hand and the lock knob with your left hand.

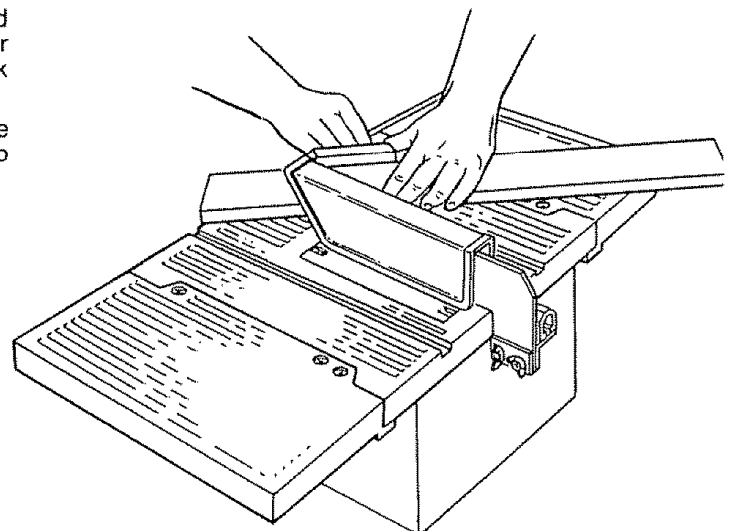
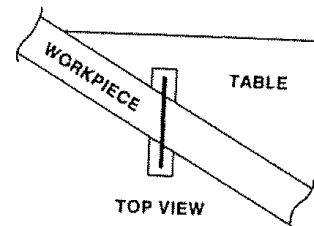

## BEVEL CROSSCUTTING

BEVEL CROSSCUTTING is the same as crosscutting except that the wood is cut at an angle . . . other than 90° with the flat side of the wood.

Adjust the blade to the desired angle.

Use the Miter Gauge in the groove to the RIGHT of the blade. It cannot be used in the groove to the LEFT because the blade guard will interfere. Hold the workpiece with your right hand and the lock knob with your left hand.

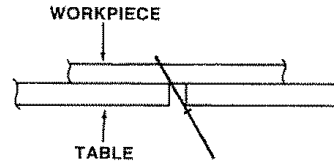

## COMPOUND MITER CUTTING

COMPOUND MITER CUTTING is a combination of miter cutting and bevel crosscutting. The cut is made at an angle other than 90° to both the edge and the flat side of the wood.

Adjust the miter gauge and the blade to the desired angle . . . Make sure miter gauge is locked.

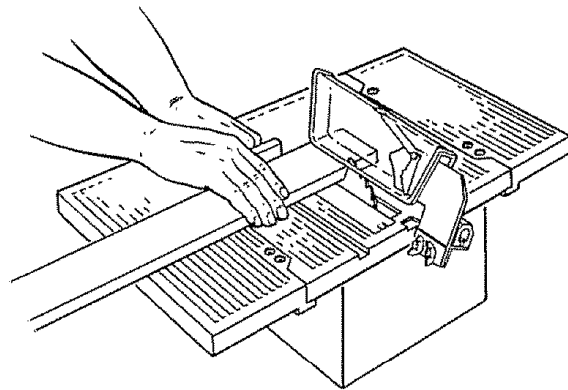

---

## USING THE RIP FENCE

**RIPPING, BEVEL RIPPING, RESAWING AND RABBETING** are performed using the RIP FENCE together with the AUXILIARY FENCE/WORK SUPPORT, PUSH STICK OR PUSH BLOCK.

**WARNING: FOR YOUR OWN SAFETY, ALWAYS OBSERVE THE FOLLOWING SAFETY PRECAUTIONS IN ADDITION TO THE SAFETY INSTRUCTIONS ON PAGES 2, 3 and 4.**

1. Never make these cuts FREEHAND (without using the rip fence or auxiliary devices when required) because the blade could bind in the cut and cause a KICKBACK.
2. Always lock the rip fence securely when in use.
3. Remove miter gauge from table.
4. Make sure blade guard is installed for all thru-sawing type cuts. Replace the guard IMMEDIATELY following completion of resawing, rabbeting, dadoing, or molding operations.

Frequently check the action of the ANTIKICKBACK PAWLS by passing the workpiece alongside of the spreader while saw is OFF.

Pull the workpiece TOWARD you. If the PAWLS do not DIG into the workpiece and HOLD it . . . the pawls must be REPLACED OR SHARPENED. See "Maintenance" section.

5. Have blade extend approximately 1/8 in. above top of workpiece. Additional blade exposure would increase the hazard potential.
6. Do not stand directly in front of the blade in case of a KICKBACK. Stand to either side of the blade.
7. Keep your hands clear of the blade and out of the path of the blade.
8. If the blade stalls or stops while cutting, TURN SWITCH OFF before attempting to free the blade.
9. Do not reach over or behind the blade to pull the workpiece through the cut . . . to support long or heavy workpieces . . . to remove small cut-off pieces of material or FOR ANY OTHER REASONS.
10. Do not pick up small pieces of cut-off material from the table. REMOVE them by pushing them OFF the table with a long stick. Otherwise they could be thrown back at you by the rear of the blade.
11. Do not remove small pieces of cut-off material that may become TRAPPED inside the blade guard while the saw is RUNNING. THIS COULD ENDANGER YOUR HANDS or cause a KICKBACK.  
Turn the saw OFF. After the blade has stopped turning, lift the guard and remove the piece.
12. If workpiece is warped, place the CONCAVE side DOWN. This will help prevent it from rocking while it is being ripped.

## RIPPING

RIPPING is cutting a piece of wood with the grain, or lengthwise. This is done using the rip fence. Position the fence to the desired WIDTH OF RIP and lock in place

Before starting to rip, be sure

- A. Rip Fence is parallel to sawblade.
- B. Spreader is properly aligned with sawblade.
- C. Anti-Kickback pawls are functioning properly.
- D. Rip fence knob is tightened to secure the fence to the table.

Position the fence to the desired WIDTH OF RIP by measuring the distance from the sawblade.

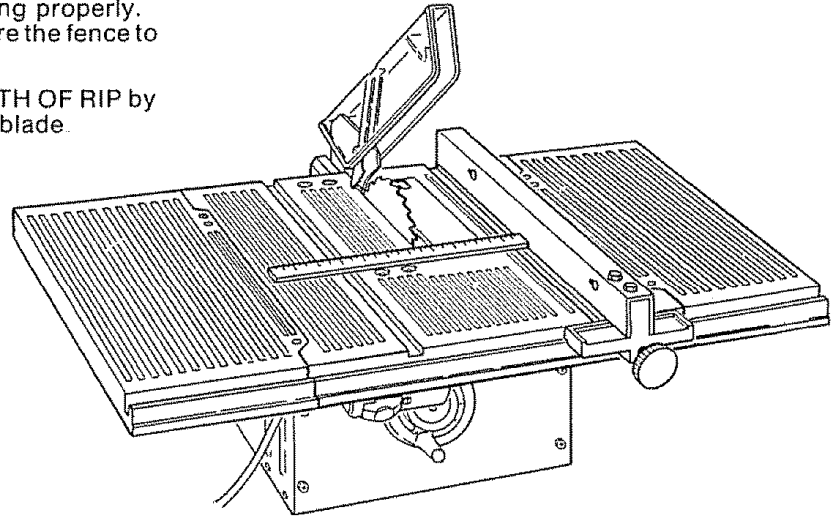
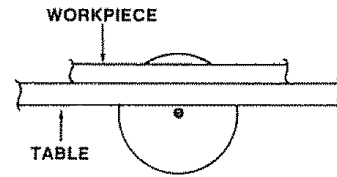

When ripping LONG BOARDS or LARGE PANELS, always use a work support.

A simple one can be made by clamping a piece of plywood to a sawhorse.

## BEVEL RIPPING

When bevel ripping material 6 in. or narrower, use fence on the right side of the blade ONLY. This will provide more space between the fence and the sawblade for use of a push stick. If the fence is mounted to the left, the sawblade guard may interfere with proper use of a push stick.

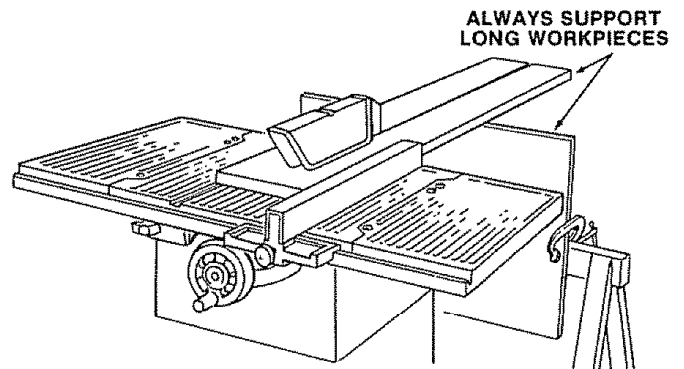

When "WIDTH OF RIP" is 6 in. and WIDER use your RIGHT hand to feed the workpiece until it is clear of the table.

Use LEFT hand ONLY to guide the workpiece ... do not PUSH the workpiece with the left hand

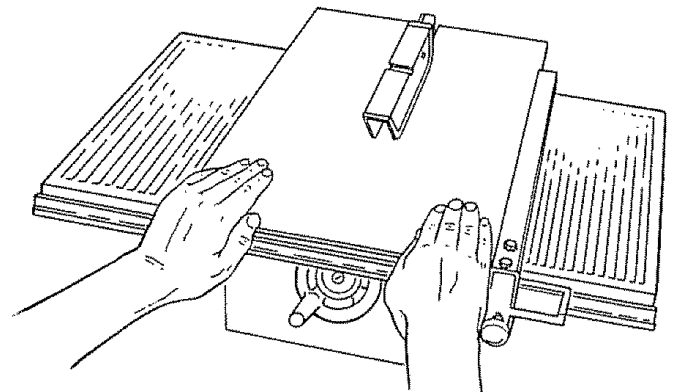

When "WIDTH OF RIP" is 2 in. to 6 in. wide USE THE PUSH STICK to feed the work.

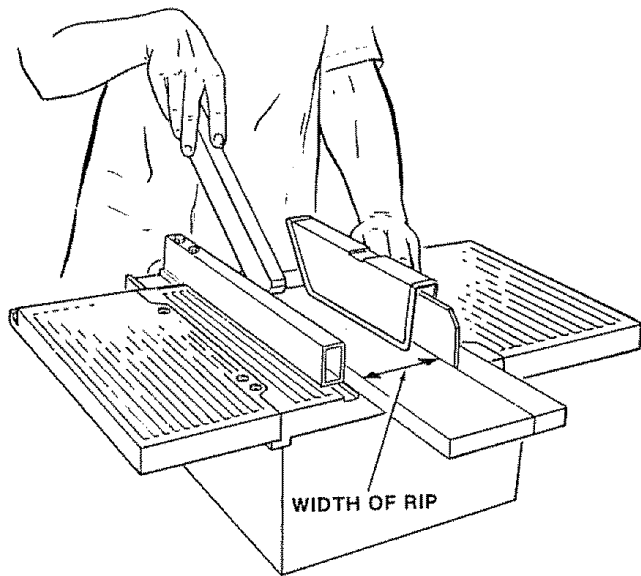

When "WIDTH OF RIP" is NARROWER than 2 in., the push stick CANNOT be used because the guard will interfere. USE the AUXILIARY FENCE/WORK SUPPORT and PUSH BLOCK.

Attach Auxiliary Fence/Work Support to rip fence with two "C" clamps.

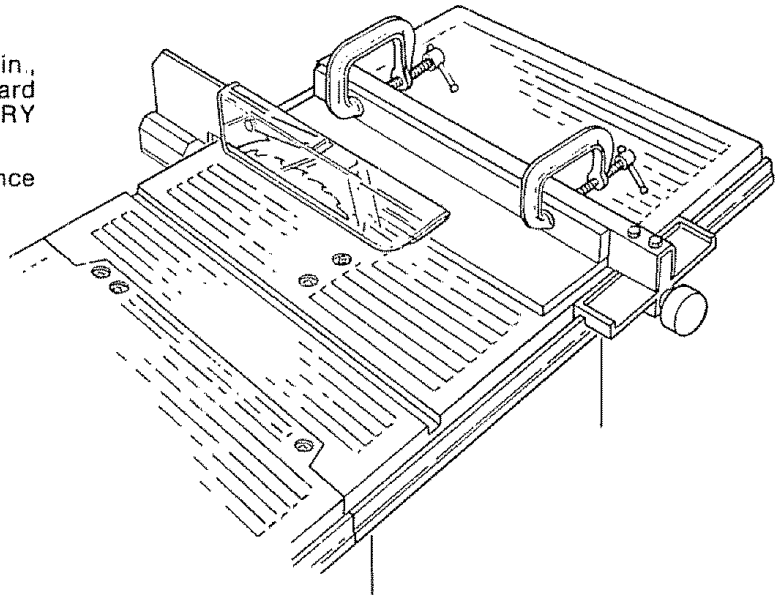

Feed the workpiece by hand along the AUXILIARY FENCE until the end is approx. 1 in. past the front edge of the table. Continue to feed using the PUSH BLOCK until the cut is complete.

Hold the workpiece in position and install the PUSH BLOCK by sliding it on top of the AUXILIARY FENCE/WORK SUPPORT (This May Raise Guard).

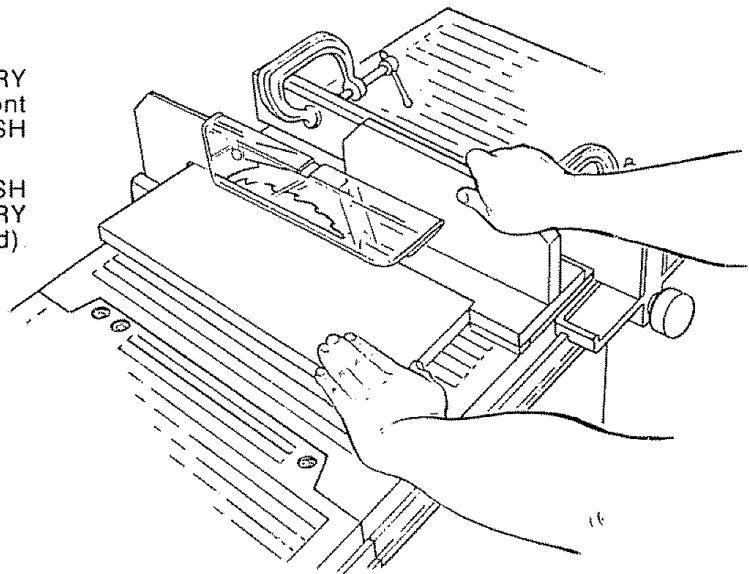

Narrow strips thicker than the Auxiliary Fence/Work Support may enter the guard and strike the baffle. CAREFULLY raise guard only enough to clear the workpiece. Use PUSH BLOCK to complete cut.

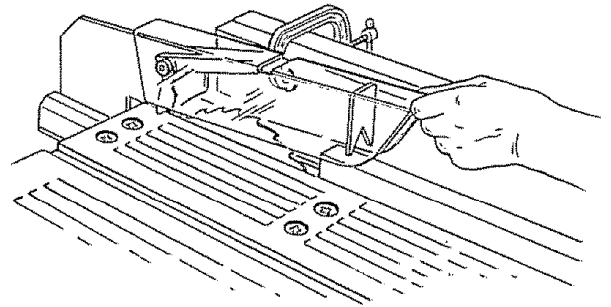
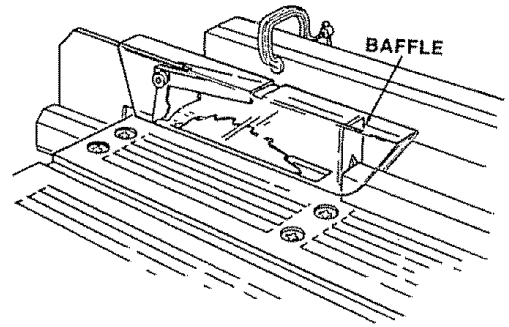

## RESAWING

RESAWING is a "thru-sawing" cut made by ripping a piece of wood through its thickness. Do not attempt to resaw BOWED or WARPED material. NOTE: To RESAW a piece of wood it will be necessary to remove the blade guard . . . and use the AUXILIARY FENCE/WORK SUPPORT. (See "Work Helpers").

Clamp it to the table so that the workpiece will SLIDE EASILY but not TILT or MOVE SIDEWAYS without BINDING between the two fences.

Do not clamp directly to the bottom edge of the table because the "swivel" of the clamp will not grip properly. Place a small block of wood between the bottom edge of the table and the "C" clamp.

**WARNING: FOR YOUR OWN SAFETY . . .**

1. DO NOT "BACK UP" (REVERSE FEEDING) WHILE RESAWING BECAUSE THIS COULD CAUSE A KICKBACK.
2. MAKE FIRST PASS TO A DEPTH SLIGHTLY LESS THAN ONE-HALF THE WIDTH OF THE BOARD; KEEP SAME FACE OF BOARD AGAINST FENCE FOR SECOND PASS AS THE FIRST PASS.
3. INSTALL BLADE GUARD IMMEDIATELY UPON COMPLETION OF THE RESAWING OPERATION.

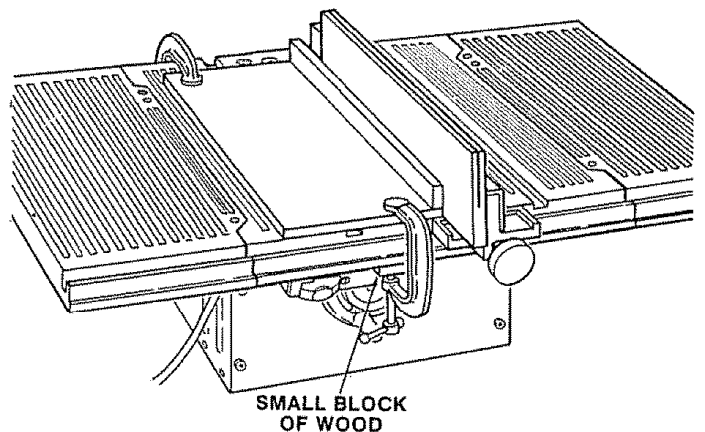

## PLOUGHING AND MOLDING

**PLOUGHING** is grooving with the grain the long way of the workpiece, using the fence. USE featherboards and push sticks as required.



PLOUGHING

**MOLDING** is shaping the workpiece with the grain the long way of the workpiece, using the fence. Use featherboards and push sticks as required.

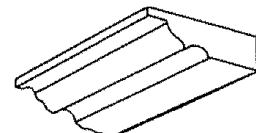

MOLDING

## RABBETING

**RABBETING** is known as cutting out a section of the corner of a piece of material, across an end or along an edge

To make a RABBET requires cuts which do not go all the way through the material. Therefore the blade guard must be removed

1. Remove blade guard
2. **For rabbeting along an edge** (long way of work-piece) as shown, add facing to rip fence approximately as high as the workpiece is wide. Adjust rip fence and blade to required dimensions; then make first cut with board flat on table as any rip (type) cut; make second cut with workpiece on edge. Follow all precautions, safety instructions, and operational instructions as for ripping, or rip type operations, including feather boards and push stick, etc
3. **For rabbeting across an end**, for workpiece 10-1/2" and narrower make the rabbet cut with the board flat on the table. Using the miter gauge fitted with a facing, follow the same procedures and instructions for cross cutting making successive cuts across the width of the workpiece to obtain the desired width of cut. **DO NOT** use the rip fence for rabbeting across the end.
4. **INSTALL BLADE GUARD IMMEDIATELY UPON COMPLETION OF RABBETING OPERATION.**

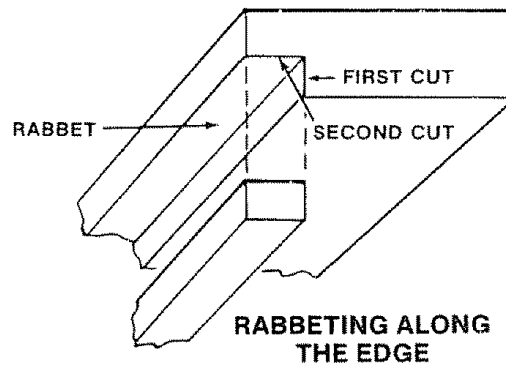

**RABBETING ALONG THE EDGE**

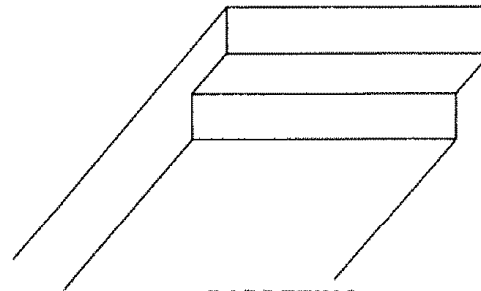

**RABBETING ACROSS THE END**

Rabbet cuts can also be made in one pass of the workpiece over the cutter using the dado head or molding head.

## DADOING

Instructions for operating the Dado Head are contained in booklet furnished with the Dado Head.

The Recommended Dado Head is listed under Recommended Accessories in this manual.

The arbor on the saw, is only long enough so that the widest cut that can be made is 1/2" wide.

Do not install the outside loose collar before screwing on the arbor nut. Make sure the arbor nut is tight.

**ALWAYS USE DADO INSERT LISTED UNDER RECOMMENDED ACCESSORIES**

When using the dado head it will be necessary to remove the Blade Guard and Spreader. **USE CAUTION. USE FEATHERBOARDS AND PUSH STICKS AS REQUIRED**

**WARNING: FOR YOUR OWN SAFETY, ALWAYS REPLACE THE BLADE, GUARD AND SPREADER WHEN YOU ARE FINISHED DADOING.**

## MOLDING CUTTING

Instructions for operating the Molding Head are contained in a booklet furnished with the Molding Head.

The recommended molding head is listed under Recommended Accessories in this manual

When using the molding head it will be necessary to remove the Blade Guard and Spreader. **USE CAUTION.**

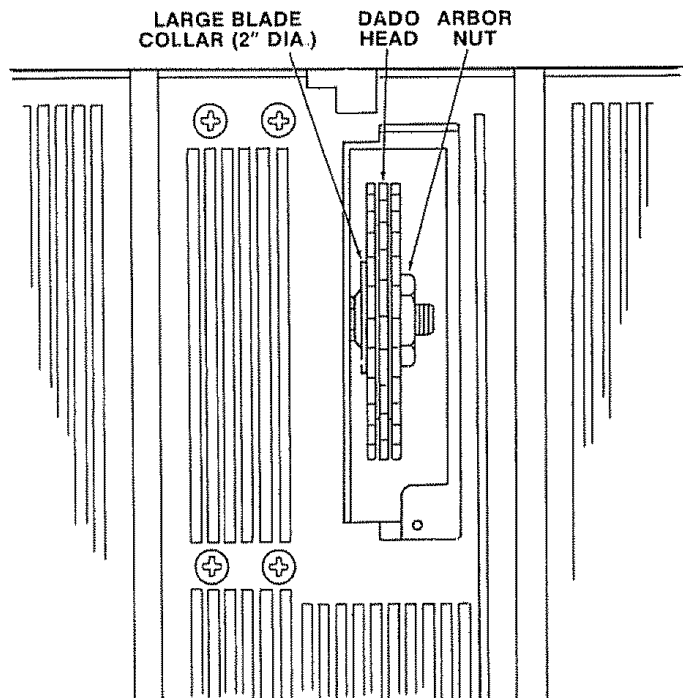

**USE FEATHERBOARDS AND PUSH STICKS, etc. AS REQUIRED**

**ALWAYS REPLACE THE BLADE GUARD AND SPREADER WHEN YOU ARE FINISHED MOLDING.**

## USING FEATHERBOARDS

Featherboards are not employed during non thru-sawing operations when using the miter gauge.

**Use featherboards for all other non "thru-sawing" operations** (when sawblade guard must be removed). Featherboards are used to keep the work in contact with the fence and table as shown, and to stop kickbacks.

Add 8 inch high flat facing board to the fence, the full length of the fence.

Mount featherboards to fence and table as shown, so that leading edges of featherboards will support workpiece until cut is complete, and the workpiece has been pushed completely past the cutter (sawblade, dado head, molding head, etc.) with a pushstick, as in ripping.

Before starting the operation (switch "OFF" and cutter below table surface):

- (a) Install featherboards so they exert pressure on the workpiece; be positive they are secure, and
- (b) Make sure by trial that the featherboards will stop a kickback if one should occur

Replace the sawblade guard as soon as the non thru-sawing operation is complete.

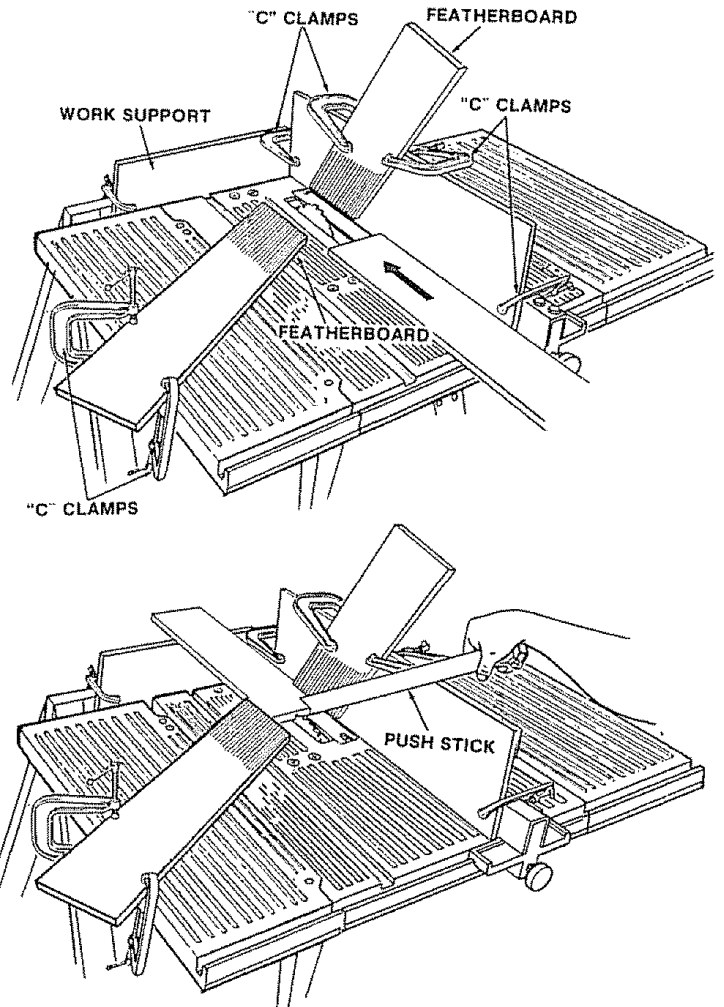

## MAINTENANCE

**WARNING: TO AVOID INJURY FROM ACCIDENTAL START, TURN SWITCH "OFF" AND REMOVE PLUG FROM POWER SOURCE OUTLET BEFORE MAINTAINING OR LUBRICATING YOUR SAW.**

Do not allow sawdust to accumulate inside the saw. Frequently blow out any dust that may accumulate inside the saw cabinet and the motor.

Frequently clean your cutting tools with Craftsman Gum and Pitch Remover.

A coat of automobile-type wax applied to the table will help to keep the surface clean and allow workpieces to slide more freely. Treat unplated and unpainted steel parts and surfaces with Sears "Stop Rust."

If the power cord is worn or cut, or damaged in any way, have it replaced immediately.

Make sure the teeth of the ANTIKICKBACK pawls are always sharp. To sharpen:

1. Identify the dull tooth or teeth. Remove blade guard.
2. Rotate pawl toward rear of spreader so that teeth are above top of spreader.
3. Hold spreader with left hand and place pawl over corner or workbench.
4. Sharpen the dull tooth using a few light strokes of a fine-cut file.

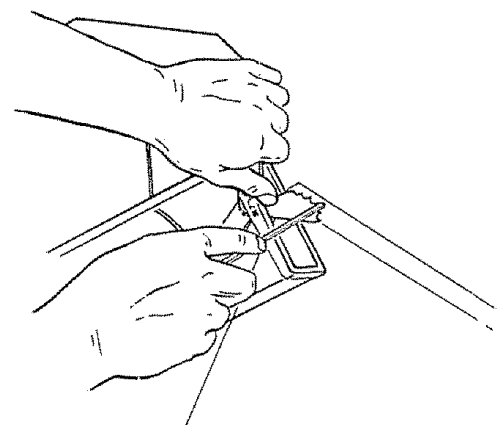

# LUBRICATION

The saw motor bearings have been packed at the factory with proper lubricant and require no additional lubrication.

The following parts should be oiled occasionally with SAE No. 20 or No. 30 engine oil.

1. Elevation guide slot and pivot.
2. Elevation screw threads.
3. Bevel screw threads (First clean with Craftsman Gum & Pitch Remover.)
4. Bevel and elevation link pivot points.
5. Cradle pivot pin bearing points.
6. Bearing points in miter gauge and rip fence.

The saw table and other major parts are made of aluminum and require no special care. A coat of automobile-type wax applied to the table will help to keep the surface clean and allow workpieces to slide more freely. Treat unplated and unpainted steel parts and surfaces with Sears "Stop Rust."

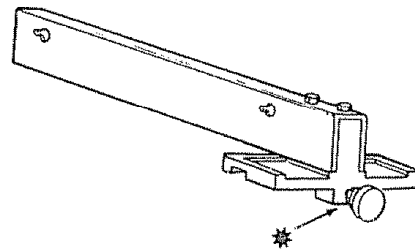
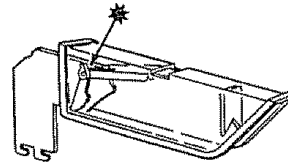
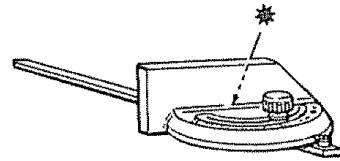

\* BEARING POINTS

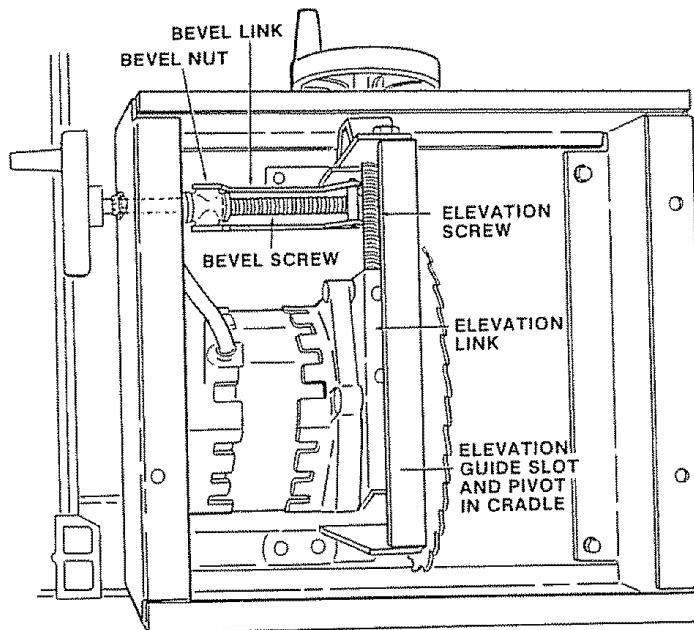

## RECOMMENDED ACCESSORIES

ITEM	CAT. NO.	ITEM	CAT. NO.
Saw Blades .....	See Catalog	Steel Legs .....	9-22236
*Molding Head Set .....	9-3222	Retractable Caster Set .....	9-22221
Dado Insert .....	9-22281		9-22222
Molding Insert .....	9-22282	"Power Tool Know How Handbook"	
Taper Jig .....	9-3233	Table Saw .....	9-2918
Dado Set .....	9-32581		

\*Smaller Diameter Molding Heads cannot be used because they do not provide adequate depth of cut

The above recommended accessories are current and were available at the time this manual was printed

## TROUBLE SHOOTING

**WARNING: TO AVOID INJURY FROM ACCIDENTAL START, TURN SWITCH "OFF" AND ALWAYS REMOVE PLUG FROM POWER SOURCE OUTLET BEFORE TROUBLE SHOOTING.**

### TROUBLE SHOOTING -- GENERAL

TROUBLE	PROBABLE CAUSE	REMEDY
<b>Excessive vibration.</b>	1 Blade out of balance	1 Discard Blade and use a different blade
<b>Cannot make square cut when crosscutting.</b>	1 Miter gauge not adjusted properly	1 See section "Miter Gauge "
<b>Cuts binds, burns or stalls motor when ripping.</b>	1 Dull blade with improper tooth set 2 Warped board 3 Rip fence not parallel to blade. 4 Spreader out of alignment	1 Sharpen or replace blade 2 Make sure concave or hollow side is facing "down" feed slowly 3 See "Assembly" section, "Aligning Rip Fence" 4 See "Assembly" section. "Installing Blade Guard "
<b>Cut not true at 90° or 45° positions.</b>	1 Stop nuts not properly adjusted	1 See "Assembly" section, "Blade Tilt, or "Squareness of Blade to Table "
<b>Tilt crank and elevating crank turn hard.</b>	1 Sawdust on threads of tilt screw or elevating screw.	1. See "Maintenance and Lubrication" section.
<b>Excessive blade wobble.</b> (Causes oversize kerf and unsmooth cut)	1. Blade has excessive wobble 2 Blade collars not installed properly	1 Replace blade 2 Make sure the large collar (2" Dia ) is between motor and blade (Installed before blade)

## TROUBLE SHOOTING — MOTOR

**NOTE:** Motors used on wood-working tools are particularly susceptible to the accumulation of sawdust and wood chips and should be blown out or "vaccummed" frequently to prevent interferences with normal motor ventilation.

**NOTE:** The starting relay is a GRAVITY SENSITIVE TYPE NEVER TURN THE POWER ON WHILE THE SAW IS UPSIDE DOWN AS THIS WILL DAMAGE THE MOTOR

TROUBLE	PROBABLE CAUSE	REMEDY
<b>Excessive noise.</b>	1 Motor	1 Have motor checked by qualified service technician Repair service is available at your nearest Sears store.
<b>Motor fails to develop full power.</b> (Power output of motor decreases rapidly with decrease in voltage at motor terminals For example, a reduction of 10% in voltage causes a reduction of 19% in maximum power output of which the motor is capable, while a reduction of 20% in voltage causes reduction of 36% in maximum power output )	1 Circuit overloaded with lights, appliances and other motors 2 Undersize wires or circuit too long 3 General overloading of power company facilities (In some sections of the country, demand for electrical power may exceed the capacity of existing generating and distribution systems ) 4 Incorrect fuses or circuit breakers in power line	1 Do not use other appliances or motors on same circuit when using the saw 2 Increase wire sizes, or reduce length of wiring See "Motor Specification and Electrical Requirements" section. 3 Request a voltage check from the power company 4 Install correct fuses or circuit breakers
<b>Motor starts slowly or fails to come up to full speed.</b>	1 Low voltage-will not trip relay. 2 Starting relay not operating	1 Request a voltage check from the power company 2 Have relay replaced.
<b>Motor overheats.</b>	1. Motor overloaded. 2. Improper cooling (Air circulation restricted through motor due to sawdust, accumulating inside of saw.	1 Do not cut so fast-Feed work slower into blade. 2 Clean out sawdust to provide normal air circulation through motor. See "Maintenance and Lubrication" section.
<b>Starting relay in motor will not operate (Motor does not come up to full speed.)</b>	1 Burned relay contacts (due to extended hold-in periods caused by low line voltage etc ). 2. Saw not in upright position. 3. Loose or broken connections	1 Have relay replaced and request a voltage check from the power company 2 Place saw in upright position 3 Have wiring checked and repaired
<b>Motor stalls</b> (resulting in blown fuses or tripped circuit breakers)	1. Starting relay not operating 2. Voltage too low to permit motor to reach operating speed 3. Fuses or circuit breakers do not have sufficient capacity.	1. Have relay replaced 2 Request a voltage check from the power company. 3 Install proper size fuses or circuit breakers.
<b>Frequent opening of fuses or circuit breakers.</b>	1 Motor overloaded. 2 Fuses or circuit breakers do not have sufficient capacity 3 Starting relay not operating (motor does not reach normal speed).	1 Don't cut so fast-Feed work slower into blade. 2 Install proper size fuses or circuit breakers 3 Have relay replaced

# REPAIR PARTS

## PARTS LIST FOR CRAFTSMAN 8 INCH DIRECT DRIVE TABLE SAW MODEL NO. 113.221611

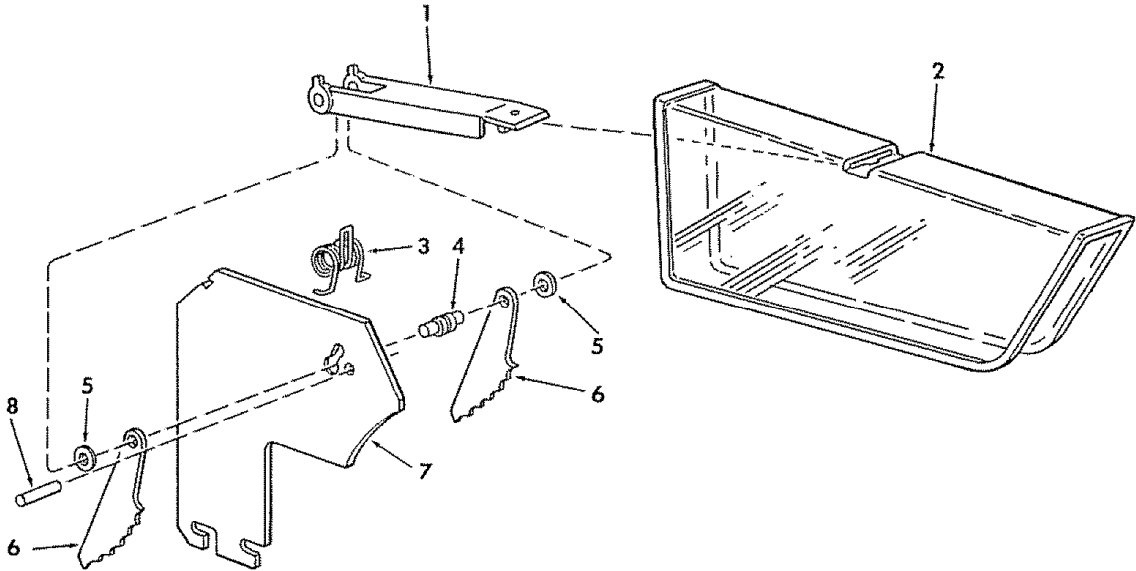

**FIGURE 1 - GUARD ASSEMBLY 62935**

**Always Order by Part Number - Not by Key Number**

Key	Part	Description
1	62916	Link, Guard
2	62911	Guard
3	62519	Spring, Pawl
4	62921	Pin
5	STD551025	*Washer, 17/64 x 1/2 x 1/32
6	62561	Pawl
7	62902	Blade, Spreader
8	455734	Pin, Roll 1/8 x 3/4

\*Standard Hardware Item - May be Purchased Locally.

**PARTS LIST FOR CRAFTSMAN 8 INCH DIRECT DRIVE TABLE SAW  
MODEL NO. 113.221611**

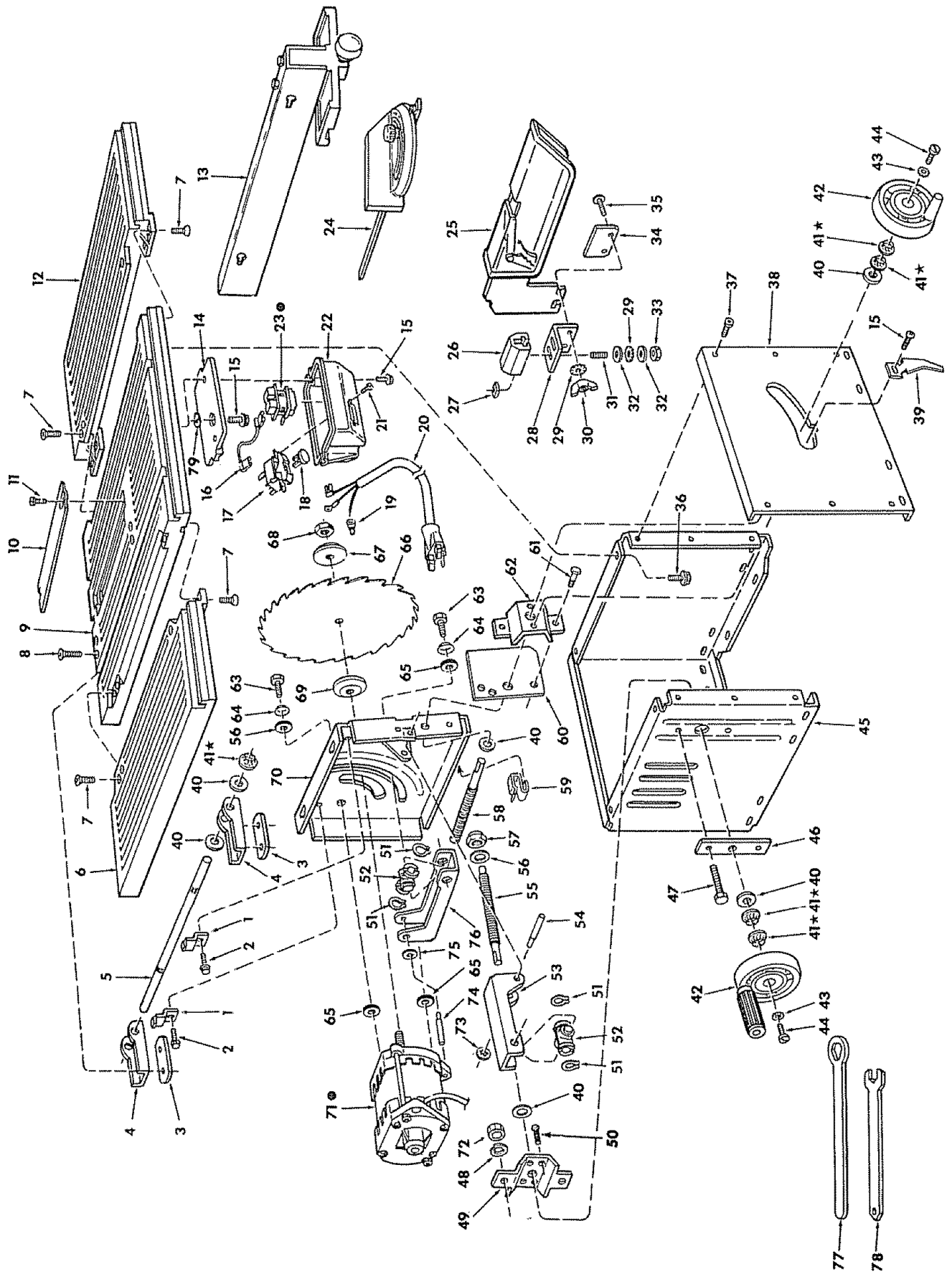

**PARTS LIST FOR CRAFTSMAN 8 INCH DIRECT DRIVE TABLE SAW  
MODEL NO. 113.221611**

**FIGURE 2**

Key No.	Part No.	Description
1	62905	Bracket, Cradle
2	STD601103	*Screw, Hex Washer Hd. Type "T" 10-32 x 3/8
3	62436	Nut
4	62625	Hanger
5	816075	Rod, Cradle
6	62908	Extension, Table L.H.
7	805297-9	Screw, Socket Flat Hd. 1/4-20 x 5/8
8	805297-1	Screw, Flat Hd. 5/16-18 x 1-1/4
9	62931	Table
10	62915	Insert, Table
11	STD600805	*Screw, Pan Hd. 8-32 x 1/2
12	62909	Extension, Table R.H.
13	62937	Fence Assy., Rip (See Fig. 3)
14	62924	Plate, Switch
15	STD601105	*Screw, Pan Hd. Cross Recess Type "T" 10-32 x 1/2
16	62936	Lead Assembly
17	62442	Switch, Locking
18	60256	Key, Locking
19	803709	Connector, Wire
20	67085	Cord with Plug
21	STD510603	*Screw, Pan Rec. Type "T" 6-32 x 3/8
22	62913	Housing, Switch
23	62925	•Relay
24	62938	Gauge Assembly, Miter (See Fig. 4)
25	62935	Guard Assembly (See Fig. 1)
26	62642	Support, Spreader
27	STD541025	*Nut, Square 1/4-20
28	62809	Bracket, Spreader
29	STD551225	*Lockwasher, External 1/4-20
30	STD541625	*Nut, Wing 1/4-20
31	60074	Screw, Socket Set 1/4-20 x 7/8
32	STD551012	*Washer, 17/64 x 9/16 x 3/64
33	STD541025	*Nut, Hex 1/4-20
34	62643	Clamp, Spreader
35	60314	Screw, Truss Hd. 1/4-20 x 5/8
36	9420417	Screw, Washer Type "T" 1/4-20 x 5/8
37	STD611005	*Screw, Pan Rec. Type "AB" No. 10 x 1/2
38	816072	Panel, Front
39	816073	Indicator, Bevel
40	STD551037	*Washer, 380 x 47/64 x 1/16

Key No.	Part No.	Description
41	60240	★Nut, Push 3/8
42	62912	Handwheel, 3-5/8
43	STD551208	*Lockwasher, No. 8
44	STD510803	*Screw, Pan 8-32 x 3/8
45	62901	Base
46	814638	Plate, Thrust
47	STD522506	*Screw, Hex 1/4-20 x 5/8
48	STD551125	*Lockwasher, 1/4
49	816071	Bracket Lead Screw
50	806752-7	Screw, Pan Hd. Type "T" 10-32 x 1-1/8
51	60540	Ring, Retaining 11/16
52	62919	Nut, Elevation
53	62917	Link
54	62923	Pin, Guide
55	816076	Shaft, Tilt
56	9414920	Washer, 17/64 x 5/8 x 1/16
57	60388	Nut, Self-Threading
58	814663	Shaft, Elevation
59	65093	Clip, Wire
60	62900	Baffle
61	60548	Screw, Hex Washer Type "T" 1/4-20 x 3/8
62	62989	Bracket, Lead Screw
63	60541	Screw, Hex Locking 1/4-20 x 3/4
64	60546	Washer, Spring
65	60545	Washer, Nylon
66	18992	†Blade, 8"
67	60547	Collar, Outer
68	6362	Nut, Saw Arbor
69	62498	Collar, Inner
70	62992	Cradle
71	62856	•Motor
72	STD541025	*Nut, Hex 1/4-20
73	60539	Ring, Retaining 1/4
74	62922	Pin, Guide
75	STD551025	*Washer, 17/64 x 1/2 x 1/32
76	814770	Link
77	3540	Wrench, Arbor
78	63062	Wrench, Shaft
79	STD551210	*Lockwasher Ext. #10
	507545	Bag of Loose Parts (Not Illustrated)
	507546	Bag of Loose Parts (Not Illustrated)
	SP5022	Owners Manual (Not Illustrated)

\*Standard Hardware Item - May be purchased locally.

†Stock Item - May be secured through the Hardware Department of most Sears Retail Stores and Catalog Order House.

★If this part is removed, discard and replace with a new Push Nut

•Relay must accompany motor when motor is returned for service. Any attempt to repair this motor may create a hazard unless repair is done by a qualified service technician. Repair service is available at your nearest Sears Store.

**PARTS LIST FOR CRAFTSMAN 8 INCH DIRECT DRIVE TABLE SAW  
MODEL NO. 113.221611**

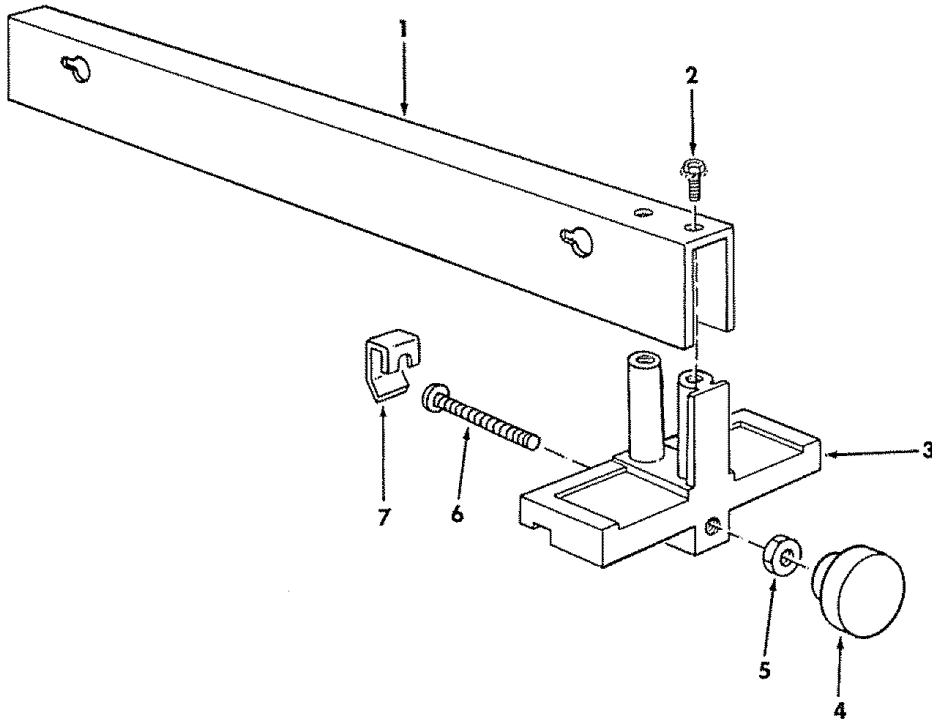
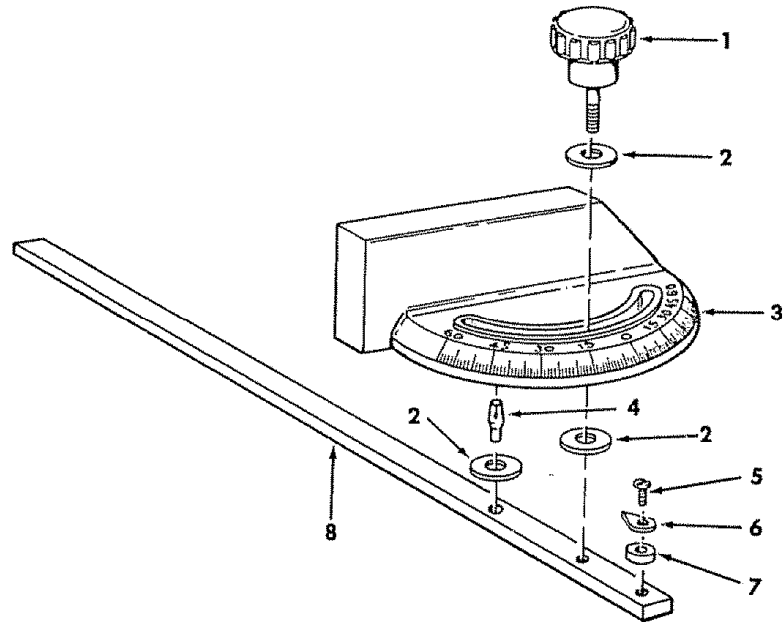

**FIGURE 3 - RIP FENCE ASSEMBLY 62937**

Key No.	Part No.	Description
1	62906	Channel, Fence
2	STD522505	*Screw, Hex Hd. Sems 1/4-20 x 1/2
3	62985	Head, Fence
4	62482	Knob, 1-1/4 Dia.
5	STD541231	*Nut, Hex Jam 5/16-18
6	60543	Screw, Truss Hd. 5/16-18 x 2
7	62939	Clip, Shoe

\*Standard Hardware Item - May be Purchased Locally.

**PARTS LIST FOR CRAFTSMAN 8 INCH DIRECT DRIVE TABLE SAW  
MODEL NO. 113.221611**



**FIGURE 4 - MITER GAUGE ASSEMBLY 62938**

Key No.	Part No.	Description
1	62176	Knob, Miter Gauge
2	STD551010	*Washer, 13/64 x 5/8 x 1/32
3	62173	Gauge, Miter
4	62175	Pin, Miter Pivot
5	STD510803	*Screw, Pan Hd. 8-32 x 3/8
6	38724	Pointer
7	60544	Spacer
8	62927	Rod, Miter Gauge

\*Standard Hardware Item - May be Purchased Locally.

# SEARS

*owners  
manual*

## SERVICE

**MODEL NO.  
113.221611**  
SAW WITH  
TABLE EXTENSIONS

## HOW TO ORDER REPAIR PARTS

## 8 INCH DIRECT DRIVE TABLE SAW

Now that you have purchased your 8 inch direct drive table saw should a need ever exist for repair parts or service, simply contact any Sears Service Center and most Sears, Roebuck and Co. stores. Be sure to provide all pertinent facts when you call or visit.

The model number of your 8 inch direct drive table saw will be found on a plate attached to your saw, at the rear of the base.

WHEN ORDERING REPAIR PARTS, ALWAYS GIVE THE FOLLOWING INFORMATION:

PART NUMBER	PART DESCRIPTION
MODEL NUMBER 113.221611	NAME OF ITEM 8 INCH DIRECT DRIVE TABLE SAW

All parts listed may be ordered from any Sears Service Center and most Sears stores. If the parts you need are not stocked locally, your order will be electronically transmitted to a Sears Repair Parts Distribution Center for handling.

**Sold by SEARS, ROEBUCK AND CO., Chicago, IL. 60684 U.S.A.**