

**Catalog Number(s): ASTM2**

Country of Origin: Made in China

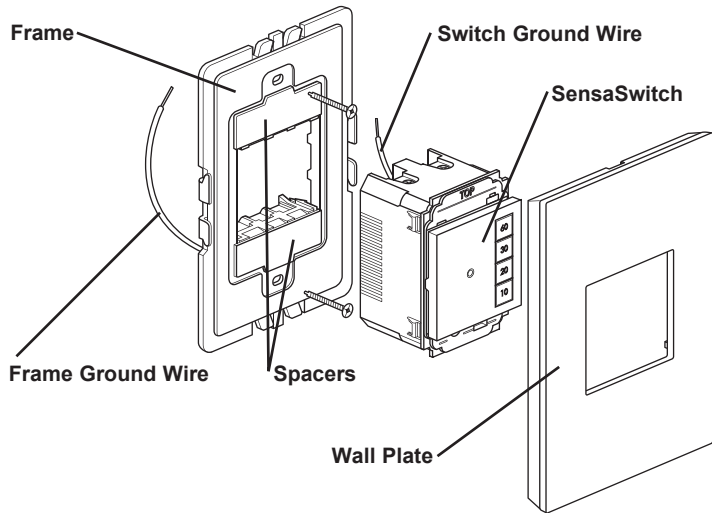

For more information and helpful how-to videos, visit [www.adornemyhome.com/install](http://www.adornemyhome.com/install).

**INSTALLATION INSTRUCTIONS**

Please read these instructions completely before you begin. **adorne™** switches are designed for installation in standard electrical boxes. However, some of the installation methods vary slightly from traditional methods. If you do not understand these instructions or are unsure of your abilities, seek the assistance of a qualified electrician.

**Remove spacers from the frame.** Since this switch fills the frame completely, you will not need the spacers. From the back of the frame, pinch the tabs on the spacer to release.

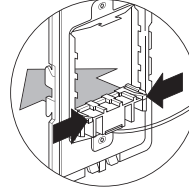

**NOTE: NEUTRAL wire is not required for sensor to function properly.**

Use only with Legrand adorne™ system.

**SPECIFICATIONS**

- Voltage - 120VAC, 60Hz
- Load (Single Pole or Multi-way)
- Incandescent or LED lamp: 0-600 Watt
- Fluorescent lamp: 0-600 VA
- Fan Motor: 1/6 hp
- Time Delay - 10, 20, 30, 60 minutes
- Environment - Residential Indoor Use Only
- Humidity - 95% RH, non-condensing

Installation Shall Be In Accordance With All Applicable Regulations, Local And NEC Codes.

# 1

**WARNING**  
To prevent severe shock or electrocution, always disconnect power at the service panel before beginning work.

When replacing existing switches, label wires before disconnecting. Disconnect old switch.

Briefly restore power and use a line voltage meter to identify the wires.

- HOT or LINE (usually black) - runs from service panel to switch
- LOAD Runs from switch to fixture
- NEUTRAL (usually white) The old switch may not have used a NEUTRAL wire, but it is usually available in the box.
- GROUND - bare copper or Green wire with or without yellow stripe

DISCONNECT power at the service panel once you've identified the wires.

**Single Pole**

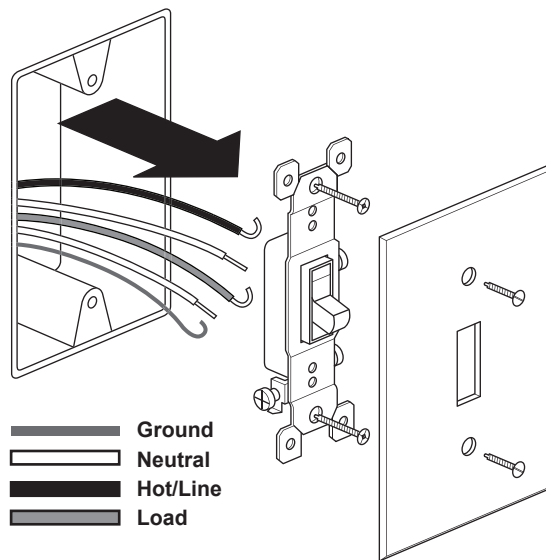

**3-Way**

In a 3-Way circuit, Traveler wires are the two insulated wires connected to the switch that are NOT the HOT wire that you identified previously.

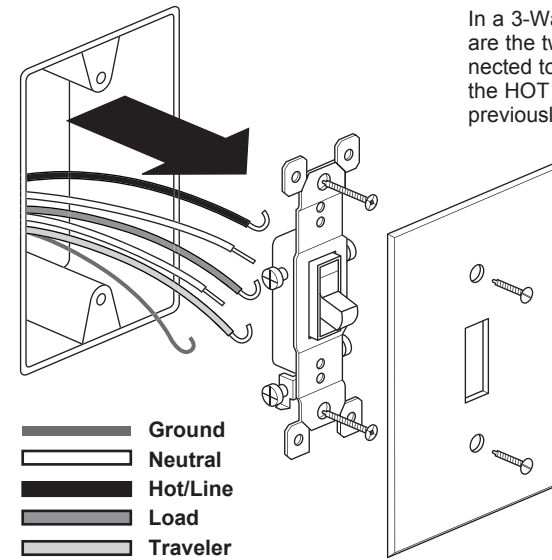

# 2

If necessary, cut wires and strip insulation using stripping guide on back of switch.

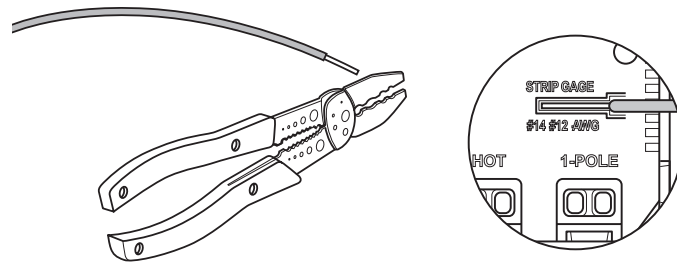

# 3

**WARNING**  
To Reduce Risk of Electrical Shock, unit shall be properly grounded in accordance with NEC and Local Codes. Failure to connect the ground wire will result in an unsafe installation that could lead to personal injury.

Connect frame ground wire and switch ground wire to bare ground wire in box. Fold ground wires into back of box. Mount frame to wall box with screws provided. Tighten screws just enough to hold frame in place. Do NOT over-tighten.

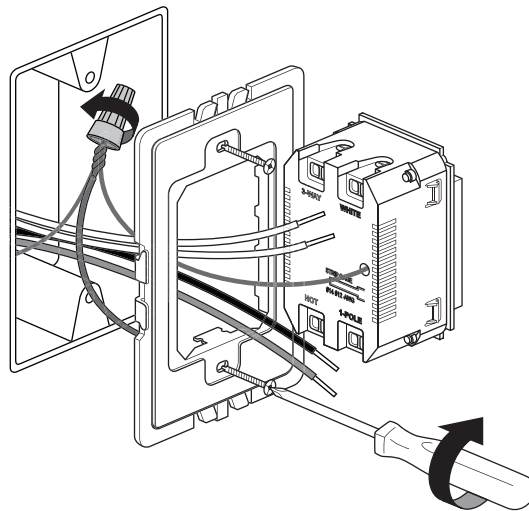

**TIPS**

- Pre-fold wires into wall box to make it easier to fit them in the box when switch is connected.
- Use caution to avoid marring wall surface with the metal frame.

# 4

**Single Pole**

Connect switch as shown. Insert wires into terminals and tighten screws securely.

- Connect LINE wire to HOT terminal on switch
- Connect LOAD wire to 1-POLE terminal
- Connect NEUTRAL from the circuit and from lamp (LOAD) to WHITE terminal

**NOTE: NEUTRAL wire is not required for sensor to function properly.**

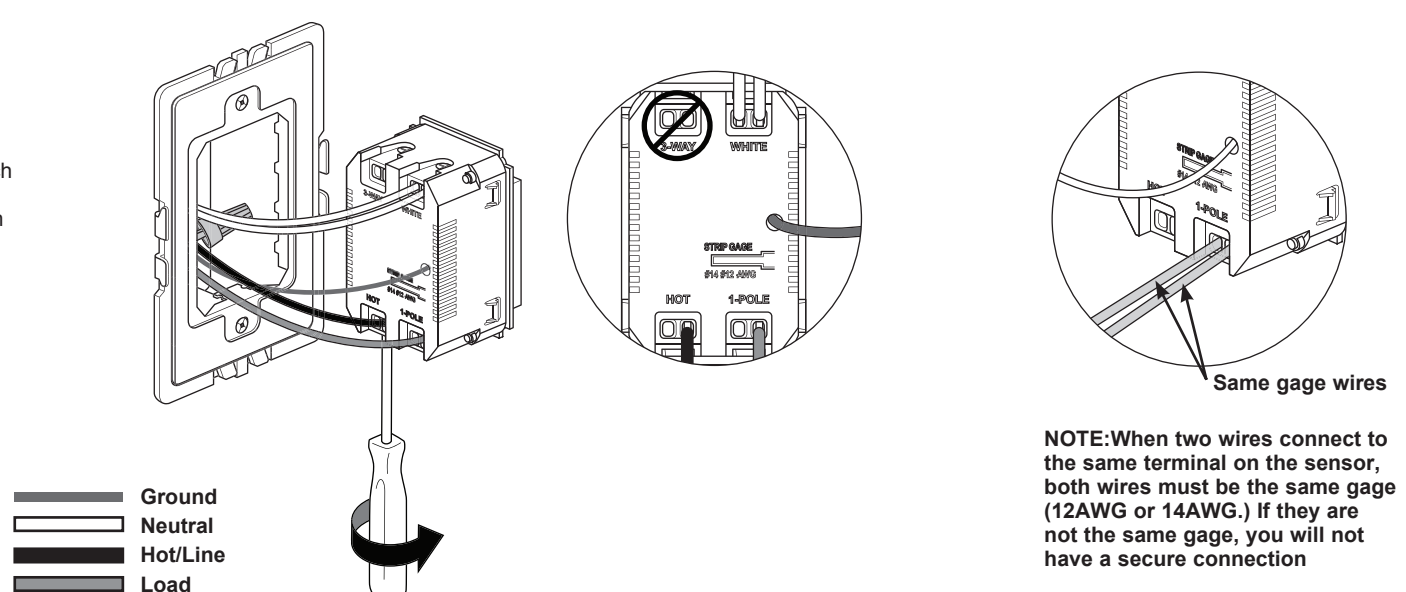

**NOTE:**When two wires connect to the same terminal on the sensor, both wires must be the same gage (12AWG or 14AWG.) If they are not the same gage, you will not have a secure connection

# 4

## 3-Way



The term master designates the sensor that connects to the load. The term auxiliary refers to the sensor that does not connect to the load.

### Master

- Connect NEUTRAL wire from the circuit and from the lamp (LOAD) to WHITE terminal
- Connect LINE wire to HOT terminal
- Connect LOAD wire to 1-POLE terminal
- Connect TRAVELER wire to the 3-WAY terminal

**NOTE: NEUTRAL wire is not required for sensor to function properly.**

### Auxiliary

- Connect NEUTRAL wire from circuit in the other wiring box to WHITE terminal
- Connect LINE wire to HOT terminal
- Connect TRAVELER wire to the 3-WAY terminal
- 1-POLE terminal on auxiliary is not used

**NOTES: A light can be controlled by one master and up to four auxiliary sensors.**

**If you are installing multiple sensors in the frame, wire all devices before snapping them into the frame.**

## 3-Way Master

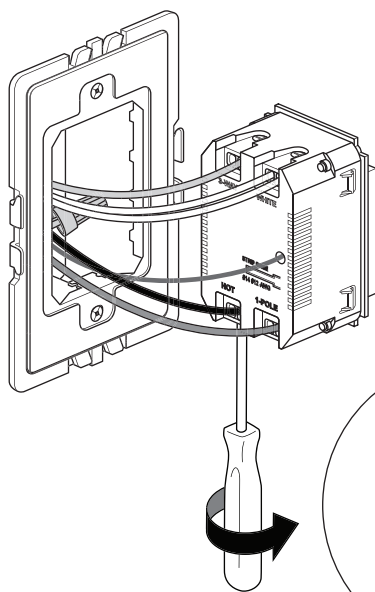

## 3-Way Auxiliary

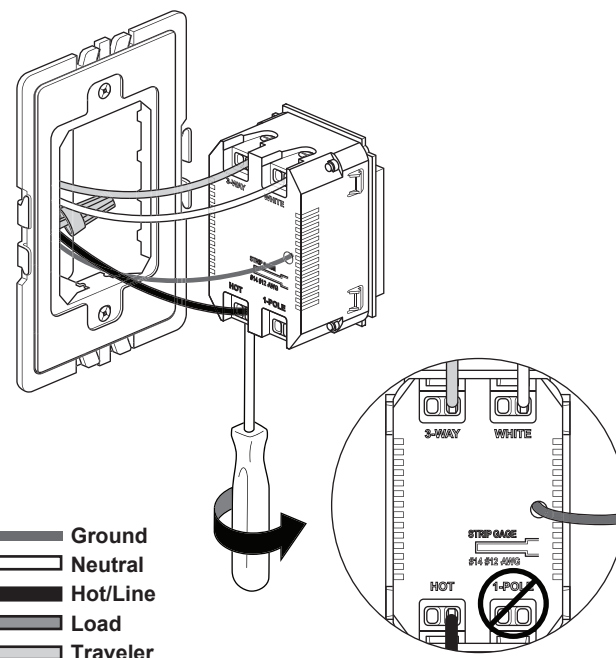

# 5

Carefully fold wires into box. Snap switch into frame.

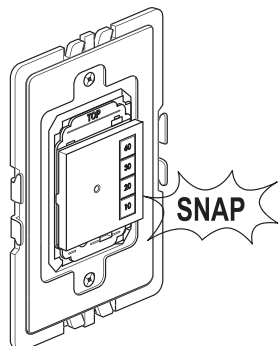

**NOTE – If you need to remove switch after snapping into frame, first remove frame from wall box to access the four locking tabs on the back of the switch. Insert a flat screwdriver to depress tabs as you apply pressure to push sensor out.**

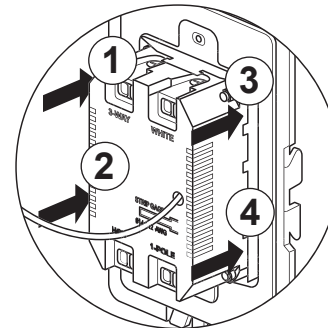

# 6

Snap wall plate to frame. There are three click-stops to adjust the fit of the wall plate to the switch and the wall.

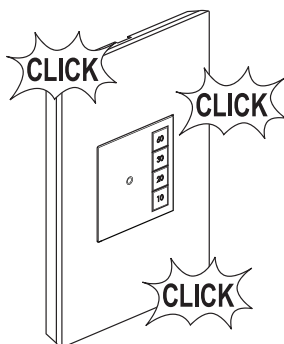

**NOTE – To remove wall plate, insert a small, flat screwdriver in notches on wall plate and twist gently to pry from frame.**

**Never apply cleaner directly to the switch or wall plate. Apply to a soft cloth and use cloth to remove any smudges from the product.**

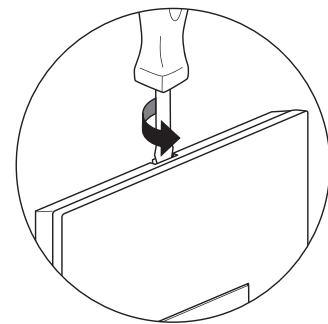

## OPERATION

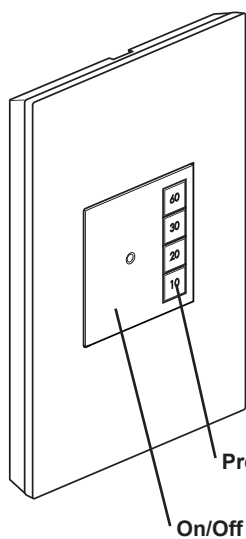

The adorne SensaSwitch - Manual ON/Timed OFF turns OFF the connected light when the selected time expires.

### Manual-On

Turn ON the connected light by pressing the desired preset time button or the ON/OFF button. If you press the ON/OFF button, it activates the time that was last used.

### Manual-off

While a timer is active, you can press the ON/OFF button to turn OFF the connected light without delay.

### Changing the selected time

If you decide that you need more or less time than you originally selected, restart the time switch by pressing the button that matches the amount of time you think you will need.

### LED functionality

The time switch has one locator LED on the ON/OFF button and each preset time button has an integral LED to illuminate the numbers on the preset time buttons. When the connected light is off the locator LED will be on. When the connected light is on the preset time button that was pressed will be illuminated and the locator LED will be off.

The preset time buttons will also function as a rough countdown timer. For example when you select 30 minutes, the 30 minute preset time button will be illuminated until 21 minutes remain in the countdown. At this point the 30 minute button will start to slowly flash for the next minute until 20 minutes are left in the countdown. Once 20 minutes are left, then the 20 minute preset button will become illuminated and the 30 minute button will turn off.

### Disabling the locator LED

The locator LED can be disabled by pressing and holding the on/off button for 10 seconds. After 10 seconds the locator LED will flash to indicate that the locator LED has been disabled. To enable the LED, press and hold the on/off button for 12 seconds. The locator LED will flash at 10 seconds, continue holding down the on/off button until the locator LED flashes twice at 12 seconds indicating that the LED has been enabled.

Note: The LEDs will only function when the neutral wire is connected. When the neutral wire is not connected the device will function properly, but the locator LED and preset time button LEDs will never be illuminated. See Step 4 above for details on how to wire the device.

## TROUBLESHOOTING

### To test the time switch:

If the neutral wire is connected, the locator LED should be ON when the switch is OFF (as long as the locator LED has not been disabled. See above.)

Press the ON/OFF button. The connected light turns ON. The connected light should turn off in the number of minutes indicated by the preset time button. You can turn the light OFF sooner by pressing the ON/OFF button again.

### Status LED is enabled and the load will not turn ON:

- Check the lamp to make sure that it has not burned out
- Turn OFF power to the circuit to check the wire connections

### No Status LED:

- Check the ground and neutral connections (note: neutral is not required for product to function properly)

### Light will not turn OFF:

- Make sure there is a solid ground connection. The device requires the ground connection to operate
- Press the ON/OFF button. If connected light or fan does not turn OFF, turn OFF power to the circuit then check wire connection.

### Factory reset

To change the operating mode back to the default settings press and hold the on/off button for 15 seconds. The locator LED will flash once at 10 seconds, continue to press and hold the on/off button. The locator LED will flash twice at 12 seconds, continue to press and hold the on/off button. The locator LED will flash 3 times at 15 seconds signaling that the device has been reset.

Technical Assistance:  
(877) 295-3472  
[www.adornemyhome.com/install](http://www.adornemyhome.com/install)

### LIMITED LIFETIME WARRANTY

Limited lifetime warranty information for adorne products is available at [www.adorne.com/warranty](http://www.adorne.com/warranty). Limited warranty information for adorne™ products may also be obtained free of charge by sending a written request, along with your proof of purchase (including purchase date), to:  
Legrand  
Attn: adorne Customer Service/Warranty Department  
50 Boyd Avenue  
Syracuse, NY 13209