



Integration Manual

MUF

I. Table of Contents

II. Overview.....	3
III. Composition.....	4
IMPINJ E710 Transceiver	4
Directional coupler	4
Host Controller.....	5
IV. RF Operation (MUF Core Module)	5
V. Specifications	6
FCC / ISED (IC) Regulatory Statements	6
FCC Statement	6
FCC Radiations Exposure Statement	7
ISED (IC) Canada Statement	7
ISED Radiation Exposure Statement	7
Integration Statement	7

II. Overview

The MUF V2 module serves as the core radio frequency (RF) engine embedded across all STid UHF RFID reader products. It operates within the 860–930 MHz frequency band, ensuring compatibility with global UHF RFID standards and enabling reliable long-range identification performance.

Designed exclusively for internal integration, the MUF V2 is a proprietary module and is not intended for standalone commercialization or external distribution. It is fully optimized to meet the performance, compliance, and robustness requirements of STid's UHF reader portfolio.

The module provides high-efficiency RF signal processing, stable communication capabilities, and seamless integration within STid hardware architectures, making it a critical component in delivering consistent and high-performance RFID reading solutions.

III. Composition

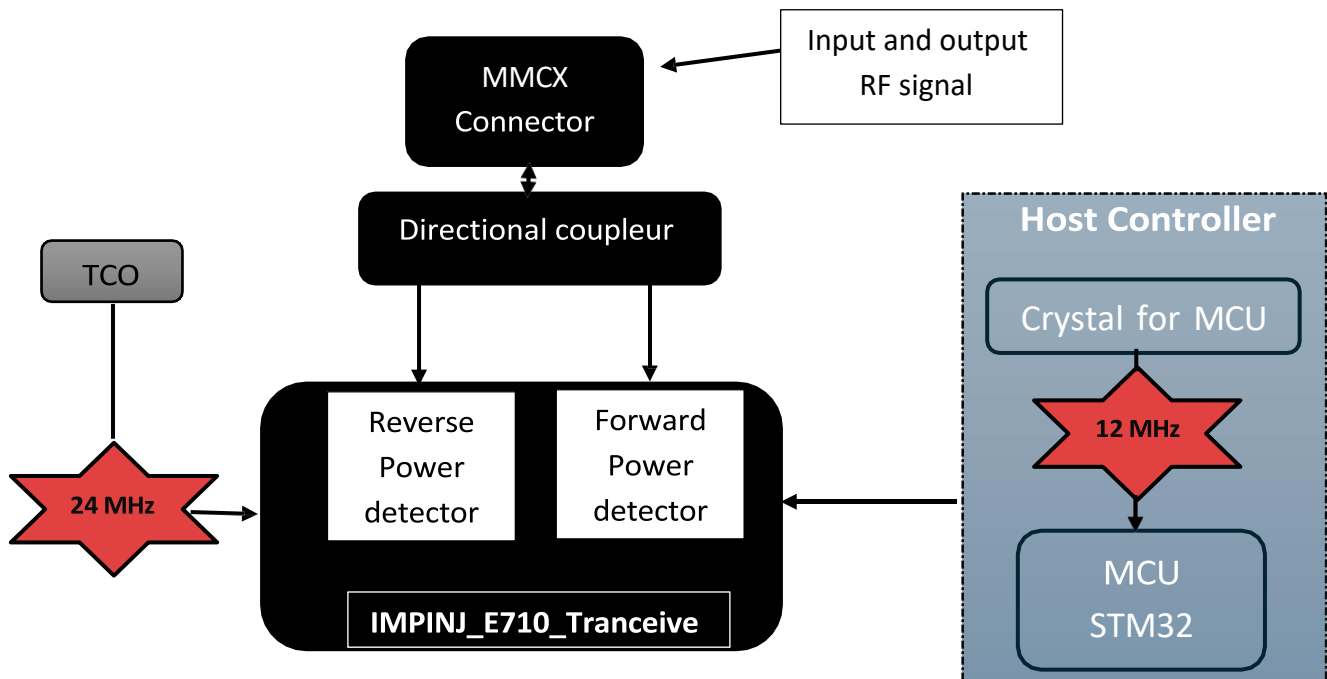

IMPINJ E710 Tranceiver

The reader chip implements direct conversation receiver architecture, and operate in the worldwide UHF industrial band. It contain all RF and baseband blocks to interrogate and receive data from compatible UHF RFID tags, and an integrated microcontroller with embedded firmware providing the GS1 UHF Gen2 RAIN protocol as a pre-integrated feature.

The Impinj E710 reader chip contain power detectors connected to the RX and LO pins, allowing measurement of forward (transmit) power on the LO pin and reverse power on the RX pin. These power detectors convert the RF power level at the RX and LO pins into analog voltages, which are measured by the Auxiliary ADC inside the reader chip.

Directional coupler

Our MUF radio transceiver board use a directional coupler to isolate the transmit (TX) signal and the receive (RX) signal, to reduce self-jammer, and to sample a local oscillator (LO) for use in self-jammer cancellation, for forward power measurement and down sampling of the received signal

Host Controller

The Host Controller is a microcontroller responsible for managing communication with the Impinj RF reader IC and controlling its operational behavior. It acts as the central interface between the system firmware and the RF front-end, issuing commands and handling data exchange required for RFID operations.

Communication between the Host Controller and the Impinj reader chip is implemented via a Serial Peripheral Interface (SPI). In this configuration, the Impinj device operates as an SPI slave, while the Host Controller functions as the master, initiating all transactions and controlling data flow. Additional digital lines are used to synchronize and manage SPI communication, ensuring reliable and deterministic operation.

The interface also includes configurable Digital Input/Output (GPIO) pins. These pins can be programmed as inputs or outputs depending on system requirements and are used to support control, status monitoring, and hardware-level signaling between the Host Controller and the RF subsystem.

IV. RF Operation (MUF Core Module)

All radio frequency (RF) operations within the STid UHF RFID reader products are fully managed and executed by the MUF module, which serves as the core RF engine of the system.

Upon power-up, the MUF module automatically performs an internal tuning and calibration procedure within its integrated RF transceiver. This process dynamically adjusts internal capacitive and resistive elements of the RF front-end to optimize impedance matching at the selected carrier frequency. As a result, the MUF ensures optimal receiver sensitivity and consistent bandwidth performance across the entire operating frequency range (typically 902 MHz to 928 MHz, depending on regional configuration).

This initial calibration is designed to guarantee proper operation across all frequency hopping channels. In addition, at each RF activation, the MUF continuously monitors matching conditions and autonomously readjusts its internal network if necessary, ensuring stable and reliable RF performance without external intervention.

The MUF module integrates a shared local oscillator for both transmission and reception paths, generated by an internal phase-locked loop (PLL) frequency synthesizer. This architecture inherently synchronizes frequency changes during hopping sequences, maintaining coherent operation between transmitter and receiver across all channels.

The receiver chain, fully embedded within the MUF, consists of an RF front-end followed by a demodulation stage specifically designed to detect and process backscattered signals from UHF RFID tags.

This high level of integration within the MUF module ensures consistent RF performance, simplifies system design, and supports compliance with regulatory and certification requirements.

V. Specifications

Item	Unit	Specification		
		Min	Typ	Max
Frequency range	MHz	865		928
Protocole « Air interface »		EPC Global UHF Class 1 Gen 2 v2 / ISO 18000-63		
Sensor		Temperature sensor		
DC Power	V		5.5	
Host Interface		SPI		
RF Output	dBm	15		32.6
RF IO Impedance	Ω		50	
Operating temperature	$^{\circ}\text{C}$	-20		+60
Dimensions	mm	93x60.5x13.1		

FCC / ISED (IC) Regulatory Statements

FCC Statement

This equipment contains an RF module (MUF V2) that has been certified in accordance with Part 15 of the FCC Rules.

This device complies with Part 15 of the FCC Rules. Operation is subject to the following two conditions:

- (1) This device may not cause harmful interference, and
- (2) This device must accept any interference received, including interference that may cause undesired operation.

The MUF V2 module is intended for integration into STid UHF RFID reader products only and is not marketed or sold as a standalone device. Final host products incorporating this module are required to comply with all applicable FCC regulations.

Any changes or modifications not expressly approved by STid could void the user's authority to operate the equipment.

FCC Radiations Exposure Statement

This equipment complies with FCC radiation exposure limits set forth for an uncontrolled environment.

The device must be installed and operated with a minimum distance of **20 cm** between the radiator and the user or nearby persons.

The host integrator is responsible for ensuring that the final product maintains compliance with applicable RF exposure requirements.

ISED (IC) Canada Statement

This device contains licence-exempt transmitter(s)/receiver(s) that comply with Innovation, Science and Economic Development Canada's licence-exempt RSS(s).

Operation is subject to the following two conditions:

- (1) This device may not cause interference, and
- (2) This device must accept any interference, including interference that may cause undesired operation of the device.

L'émetteur/récepteur exempt de licence contenu dans le présent appareil est conforme aux CNR d'Innovation, Sciences et Développement économique Canada applicables aux appareils radio exempts de licence. L'exploitation est autorisée aux deux conditions suivantes :

- (1) L'appareil ne doit pas produire de brouillage ;
- (2) L'appareil doit accepter tout brouillage radioélectrique subi, même si le brouillage est susceptible d'en compromettre le fonctionnement.

ISED Radiation Exposure Statement

This equipment complies with ISED radiation exposure limits set forth for an uncontrolled environment.

This equipment should be installed and operated with a minimum distance of **20 cm** between the radiator and the user.

OEM integration Requirements

General Conditions

This device is intended only for OEM integrators under the following conditions:

- The MUF module must be installed such that a minimum separation distance of 20 cm is maintained between the radiator (antenna) and body.
- The MUF module is limited to installation in fixed applications.
- The transmitter module must not be co-located or operating in conjunction with any other antenna or transmitter, except in accordance with FCC multi-transmitter product procedures.
- The MUF module must only be used with the included onboard antenna or antenna approved by the manufacturer (STiD). Use of unauthorized antenna is strictly prohibited.
- The OEM integrator is responsible for ensuring that the end-user manual does not contain instructions on how to install or remove the RF module.
- The OEM integrator must include the required FCC and ISED statements (per FCC Part 15.19 and 15.21 and ISED RSS-GEN §4) in the user manual of the host device.
- The user manual for the host product must clearly indicate the operating requirements and conditions to ensure compliance with current FCC and ISED RF exposure guidelines.

Labeling Requirements

The module is labeled with its own FCC ID and IC ID. If the FCC ID and IC ID are not visible when the module is installed inside another device, the outside of the device must also display a label referring to the enclosed module:

Example:

“Contains FCC ID: **OVNMUF**” and “Contains IC: **10520A-MUF**”.

To satisfy FCC exterior labeling requirements, the final product must include the above statement in a visible location.

Additional Compliance

- The OEM integrator is still responsible for testing the final product for any additional compliance requirements (e.g., digital device emissions under Part 15B and RSS-GEN).
- The integration of the MUF module into a host device will require a Class II Permissive Change application with the FCC rules and a Class IV Permissive Change application with ISED rules.