

Visit Our Website



**SCAN ME**  
serenelifehome.com

# SereneLife



SLBS66



SLBS66P



SLBS66G

## ***SLBS66 - SLBS66P - SLBS66G*** **Baby & Toddler Booster Seat**

# ***USER GUIDE***

## **Features:**

- Home Living Baby Booster Seat
- Lightweight & Portable Booster Feeding Chair
- Used for Mealtime Food Serving & Playtime Activities
- Folding Design for Portability
- Safe, Sturdy & Comfortable Baby Chair
- Hassle-Free Quick Setup: No Assembly Required
- Soft & Comfortable, Non-Irritating Fabric Material
- Built-in Locking Child Safety Belt
- Environmentally Friendly Construction
- Stain-Resistant & Easy-to-Clean
- Food Grade Safe Serving Tray
- Snack Time & Food Chair Used for Baby, Toddler, Small Children

## **What's in the Box:**

- Baby Booster Seat
- Seat Cushion
- (2) Child Safety Belts
- Detachable Food Tray
- Storage / Travel Bag

## **Technical Specs:**

- Suitable for Ages: 6 Months to 3 Years
- Maximum Support Weight: 37 lbs.
- Construction Material: Engineered ABS, Oxford Fabric, Reinforced Aluminum Metal Frame
- Total Assembled Chair Size (L x W x H): 15.0" x 14.2" x 15.4" -inches

### **California Prop 65 Warning**

#### **⚠️ WARNING:**

This product contains Cadmium which is known to the state of California to cause cancer birth defects and other reproductive harm.

Do not ingest. For more info go to: [www.P65warnings.ca.gov](http://www.P65warnings.ca.gov)

**Please read the following instructions and warnings carefully.**

**KEEP THIS INSTRUCTION MANUAL FOR FUTURE REFERENCE.**

**No tools required. For use with children from 6 months up to 37 lbs.**

## **WARNING**

- Prevent serious injury or death from sliding out, falling, or tipping over.
- Never leave your child unattended or unsupervised.
- Always secure the child using restraint straps until they can get in and out of the booster seat independently (around 2 ½ years old).
- The tray is not designed to hold the child in the chair.
- Do not use in motor vehicles.
- Always secure both the back and seat straps to an adult chair.
- Always check the security of the fit to the adult chair before each use.
- Never allow the child to push away from the table.
- Never lift this product with your child in it.
- Do not use this product if it is damaged or broken.
- Never use this product as a car seat or bath seat, or on a table, countertop, stool, swivel chair, folding chair, unstable chair, or any chair where the straps cannot secure it properly.
- Use only on a chair with seat dimensions larger than the booster seat.
- Check that both the floor and seat of the chair are level before installing the booster seat.
- Prevent finger injuries: Unfold the booster seat completely before use. Keep the child away from the booster seat when folding and unfolding.
- Prevent falls: Always use booster chair straps when using this product on elevated surfaces as a booster seat.

## Components

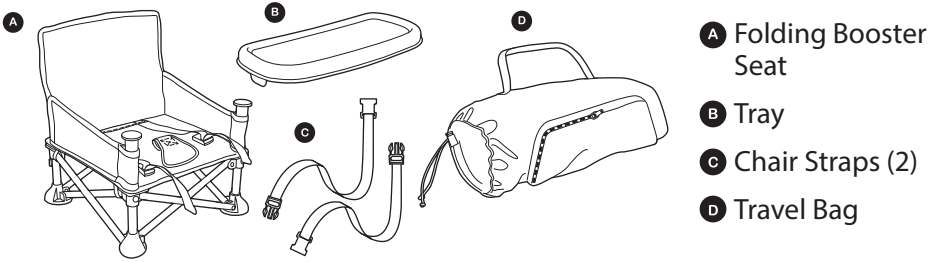

## Assembly

**1** Remove the tray and booster seat

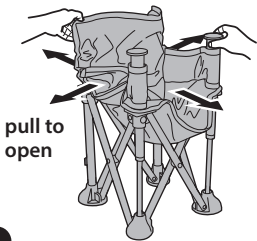
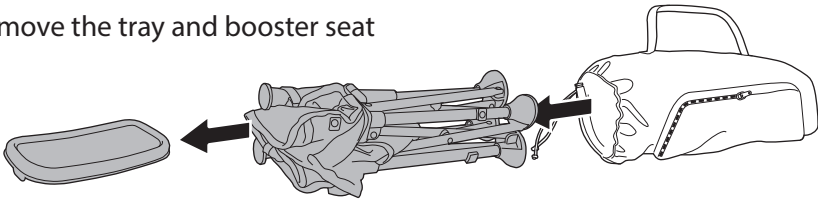

**!** Note:  
Before use, press down on the seat to ensure the legs and seat are fully open.

**2** Squeeze the levers on the tray and slide it onto the booster

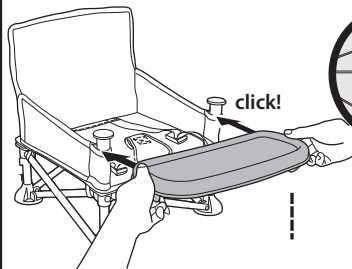

**!** Note:  
Before use, ensure the tray connection is secure

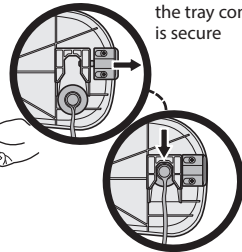

**FINISHED 3**

## Securing booster to chair

1. Unzip the pocket of the travel bag and remove both sets of chair straps.

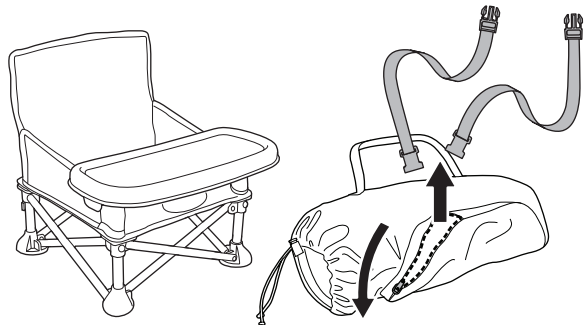

## Securing booster to chair (continued)

Attach one strap to the rear leg and one strap to the crossbars on the booster's side



Repeat with the two remaining straps on the opposite side of the chair

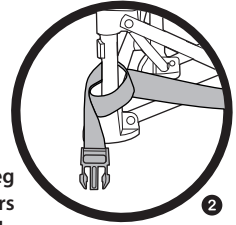
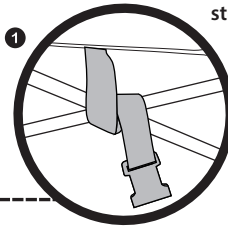

Attach one strap to the rear leg and one strap to the crossbars on the booster's side

**1<sup>st</sup>**  
Place the booster seat on the chair

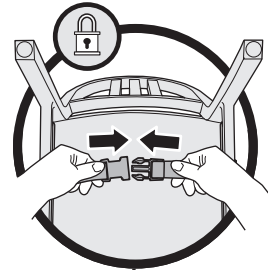
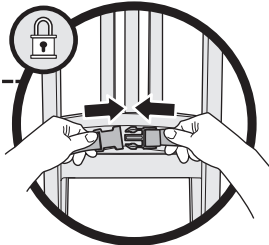
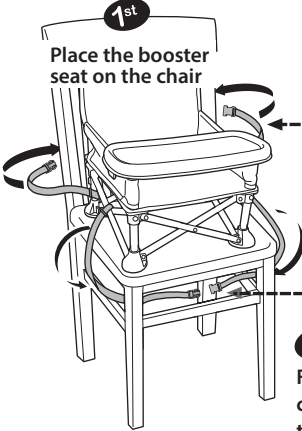

**2<sup>nd</sup>**  
Fasten the clips around the chair back and underneath the chair seat

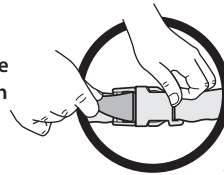

**3<sup>rd</sup>**  
Be sure to tighten the straps securely

## Child restraint

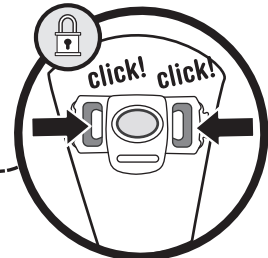
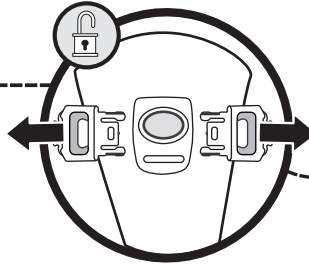
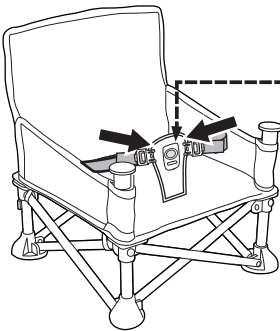

**! WARNING**

Prevent serious injury or death from falls or sliding out. Always use the restraint system.

## Tray removal

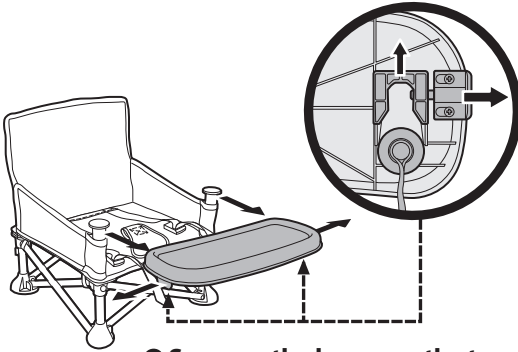

① Squeeze the levers on the tray and slide it off the booster

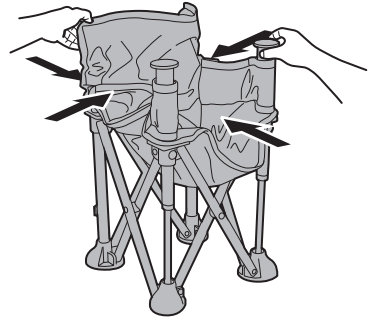

② Lift the seat and push it closed

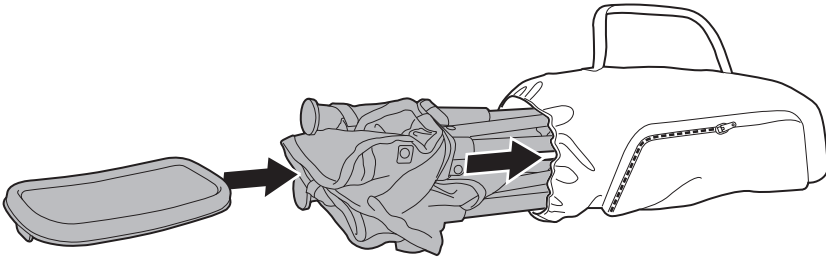

③ Slide the tray and booster seat into the travel bag

## Cleaning, Maintenance, and Storage

Before each use, inspect the booster for damaged hardware, loose joints, missing parts, or sharp edges. Do not use the booster if any parts are missing, torn, or broken.

### To clean the booster seat and chair straps:

- Wipe clean with a damp cloth or sponge using mild soap and warm water.
- Towel dry or air dry before storing.
- **The tray is dishwasher safe (top rack only).**

## Maintenance:

- Regularly inspect the booster seat for loose joints, damaged hardware, missing parts, or sharp edges.
- Do not use if any parts are missing, torn, or broken.
- Ensure all straps and buckles function properly before each use.

## Storage:

- Fold the booster seat by lifting the seat and pushing it closed.
- Store the tray and booster inside the travel bag when not in use.
- Keep in a cool, dry place away from direct sunlight to prolong the product's lifespan.



## Register Product

Thank you for choosing SereneLife. By registering your product, you ensure that you receive the full benefits of our exclusive warranty and personalized customer support. Complete the form to access expert support and to keep your SereneLife purchase in perfect condition.

## Start Here



Model Number:

**SLBS66**

[Serenelifehome.com/pages/register](http://Serenelifehome.com/pages/register)

serenelife™



***Questions or Comments?***

**We are here to help!**

**Phone: 1.718.535.1800**

**[Serenelifehome.com/ContactUs](http://Serenelifehome.com/ContactUs)**