

Universal Pump Locations

The universal fuel pump should be mounted below the fuel tank, as all pumps do not have equal lift capabilities. Also, the pump must be mounted below the carburetor to avoid possible vapor lock conditions occurring.

Under no circumstances should the pump be mounted in the trunk, inside the vehicle, or in the engine compartment; personal injury could occur in the event of a fuel line rupture.

Always mount a good quality fuel filter on the inlet side of the pump. Failure to do so will void the warranty.

Do not mount the pump near exhaust system components, as heat contributes to vapor lock.

Care should be exercised to protect the pump from splash or water immersion.

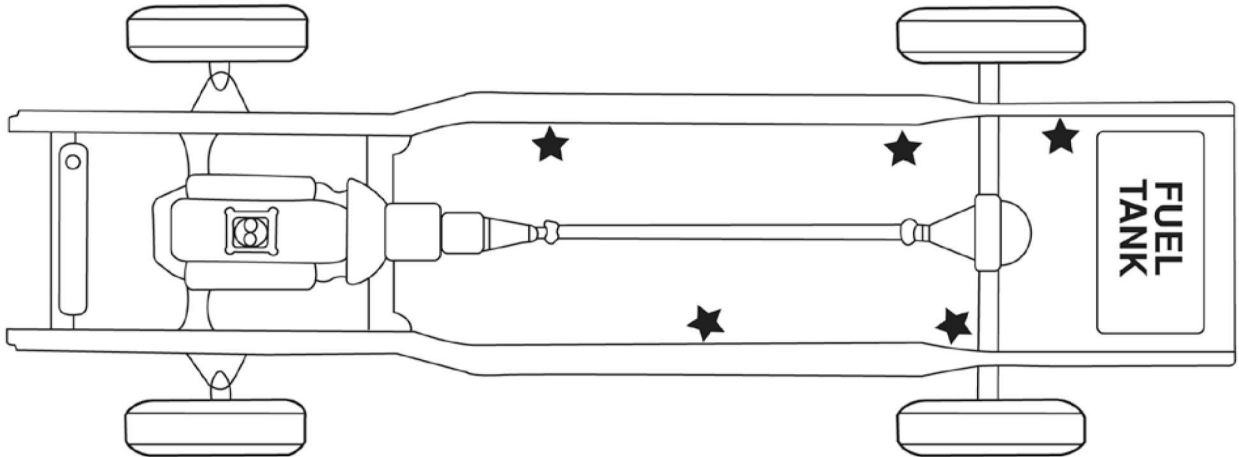

NOTE: NOT ALL UNIVERSAL ELECTRIC FUEL PUMPS ARE CAPABLE OF A PULL-THROUGH ARRANGEMENT WITH AN EXISTING MECHANICAL FUEL PUMP SYSTEM. CHECK INFORMATION ON ALL UNIVERSAL ELECTRIC PUMPS.

Safety Interlock System

PRESSURE SAFETY SWITCH A-68301 INSTALLATION INSTRUCTIONS

A pressure switch should always be used in conjunction with the Universal In-Line Electric Fuel Pump. ICC Motor Carrier Safety Regulations stipulate that the fuel pump must not continue to operate after the engine stops. The Safety Interlock Circuit stops the electric fuel pump when the engine stops even though the ignition switch is not turned "Off." The pressure switch is a single-pole, double-throw, diaphragm-actuated switch. Terminals P (Pump) and S (Start) are normally closed; terminals P (Pump) and I (Ignition) are normally open. This allows the fuel pump to operate and fill the carburetor while the engine is cranking. When oil pressure exists (2 to 4-1/2 psi), the P and S terminals are opened, and the P and I are closed. The diaphragm is treated to withstand pressure up to 150 psi.

If the oil pressure drops below 2 psi, the connection between P and I opens and the fuel pump stops. This also protects the engine from severe damage if an oil line is broken or the oil level in the crankcase becomes extremely low.

Full battery voltage must be available to the pump when the ignition switch is in the start or run position. Do not connect to the ignition coil, as a ballast resistor may be built into the wire.

The pressure switch should be installed at a convenient location in the engine oil pressure system. In some instances, it may be necessary to install a "T" fitting below the existing oil gauge sender or dashlight unit.

Wires should be 18-gauge insulated, or heavier, routed so as to protect them from exhaust heat, and anchored securely at frequent intervals to prevent chafing.

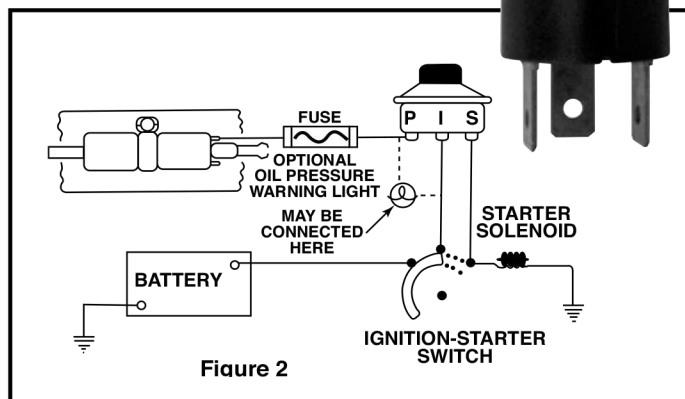

Figure 2

Rotary Vane

BEFORE YOU BEGIN:

- BEFORE REPLACING ANY ELECTRIC FUEL PUMP, DIAGNOSE THE CAUSE OF FAILURE.
- DIRT IS THE MAJOR CAUSE OF PUMP FAILURE, SO THE TANK MUST BE CLEANED OUT OR DIRT MAY CAUSE THE REPLACEMENT PUMP TO FAIL AS WELL.
- INSTALLATION OF THE REPLACEMENT PUMP MAY REQUIRE THAT SOME OF THE MOUNTING OR ELECTRICAL COMPONENTS BE REUSED. DO NOT DISCARD ANY PARTS.
- TO PREVENT FUEL PUMP FAILURE, INSTALLATION OF A HIGH QUALITY FUEL FILTER ON THE INLET SIDE OF THE PUMP IS REQUIRED.

ADDITIONAL NOTES:

- A. BECAUSE OF THEIR CONSTRUCTION, ALL ELECTRIC PUMPS EMIT NOISE DURING NORMAL OPERATION. FOR PASSENGER CAR USE, WHERE QUIET OPERATION IS DESIRED, IT IS RECOMMENDED THAT A QUIET PACK 18-14U BE INSTALLED WITH THIS PUMP.
- B. FOR RACING APPLICATIONS WHERE AN ELECTRIC PUMP IS BEING USED AS A BOOSTER FOR A MECHANICAL PUMP, IT IS RECOMMENDED THAT A HIGH PERFORMANCE MECHANICAL PUMP, WHICH INCORPORATES A HEAVIER DIAPHRAGM, BE INSTALLED.
- C. IF A HIGH PERFORMANCE MECHANICAL PUMP IS NOT INSTALLED, REMOVE THE STOCK PUMP AND ACTUATING PUSH ROD (IF USED) AND SEAL THE OPENING IN THE ENGINE WITH A METAL COVER PLATE AND GASKET.
- D. WHEN USING TWO ELECTRIC PUMPS, CONNECT THE FUEL LINES IN PARALLEL, NOT SERIES. THIS GIVES INCREASED VOLUME WITHOUT EXCESS PRESSURE. A 3/8" FUEL LINE SHOULD BE USED THROUGHOUT THE SYSTEM TO AVOID RESTRICTIONS.

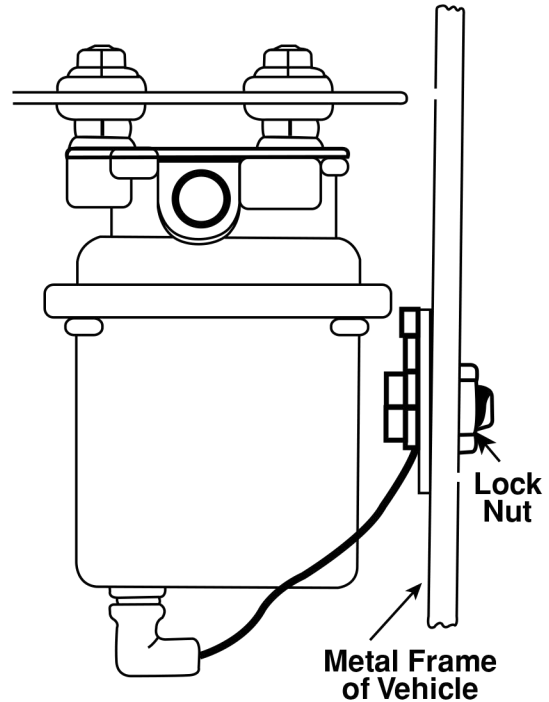

Fig. 1

IMPORTANT NOTICE: A PRESSURE REGULATOR, 404-500HP OR EQUIVALENT, IS REQUIRED WHEN INSTALLING PUMP P4601HP.

INSTALLATION STEPS

1. Disconnect the negative battery cable.
2. Disconnect fuel lines from old pump and join them together by means of a union fitting, or with a short length of hose clamped to each line. If pump is a combination vacuum booster type for windshield wipers it must be left in place. The outlet port of the pump should always be plugged whenever it is not removed from the engine. If the pump is not a combination pump, it can be removed and the opening sealed with an appropriate sheet metal plate and gasket. For normal operation, the electric pump should never be used as a booster for a mechanical pump; it should always be used separately. For special or racing applications where an electric pump is going to be used in conjunction with a mechanical pump, a special high performance mechanical pump should be installed. (See your supplier for complete list of Competition Series mechanical pumps.) When not using a special high performance mechanical fuel pump, remove or bypass as explained above.
3. Select the best location along the fuel line, away from heat and road splash, and as close to the fuel tank as possible. It is recommended that pump be mounted on the frame, never more than 24 inches above bottom of gas tank. MOUNT PUMP WITH ELECTRIC TERMINAL POINTING DOWN AS SHOWN. (See Fig. 1) For safety reasons and improved performance, DO NOT MOUNT PUMP IN TRUNK. Cut out section of fuel line as desired to make an easy installation.
4. Use mounting bracket as a template to drill two 1/4" holes in frame. Position pump on bracket as indicated in Fig. 1. The "IN" port of pump must be connected to the line running from gas tank. Push rubber grommet in appropriate holes. Push pump studs through rubber grommet, using a flat washer on each side of the rubber grommet, and tighten down evenly with lock washers and nuts.

(con't on next page)

Rotary Vane

(con't from previous page)

5. Anchor mounting bracket to frame with two self-tapping screws. Install the free end of the ground wire to the correct polarity terminal on pump. Press rubber boot firmly onto threaded post, making sure rubber boot seals around plastic washer. PUMP GROUND POLARITY MUST BE SAME AS BATTERY GROUND POLARITY. Install the other end of ground lead under a bracket mounting screw hose before tightening. Tighten bracket to frame and install lock nuts on the exposed threads of each screw. (See Fig. 2) Install hose fittings in pump.

6. Use short section of hose and connect pump to gas line as indicated in Fig. 2. Use blue colored clamps to connect hose to inlet and outlet pump fitting. When connecting hose to 5/16" gas lines, use smaller clamps. When connecting to 3/8" line, use larger clamps.

7. Solder a length of #14 or heavier wire to the hot wire assembly to connect it to the safety switch or ignition switch. Use non-corrosive soldering flux (not acid core) and tape the connection securely. The use of plastic insulated wire is suggested, as it is less susceptible to damage from salt spray. Press rubber boot onto threaded post of hot (+) terminal of pump. Push down firmly, making sure rubber boot seals around plastic washer. Route wire so as to protect it as much as possible from heat and road hazards. Anchor wire securely at frequent intervals to prevent vibration or chafing.

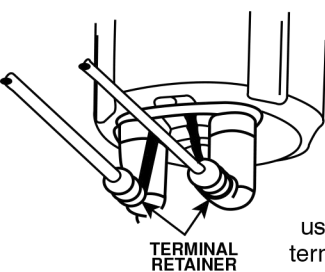

TERMINAL RETAINER

If the Safety Circuit is not used, connect wire to the "ON" terminal of ignition switch if conditions will permit. Connection can be made at any point between

ignition switch and resistor or ballast in the primary circuit (used in most 12-volt systems). Install a 10-amp fuse between the oil pressure safety switch and the pump. Care must be exercised as some car manufacturers incorporate this resistance in a wire located within the wiring harness. Full battery voltage must be available to the pump when the ignition switch is in the "ON" position. (See Fig. 3)

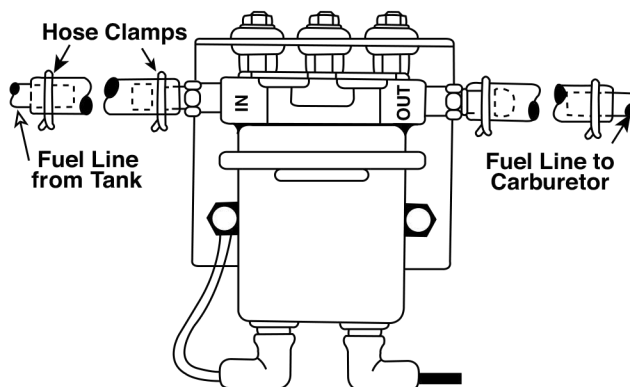
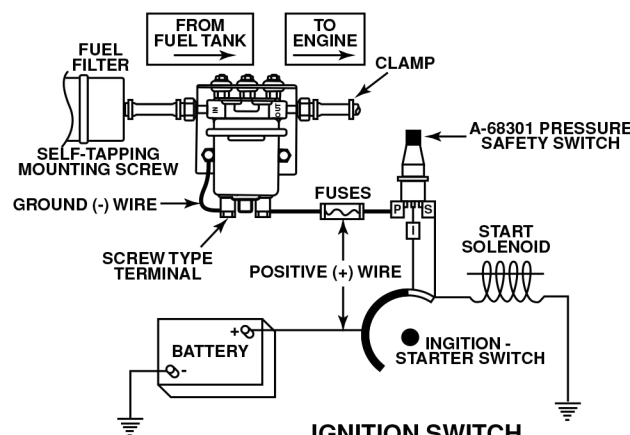

Fig. 2



IGNITION SWITCH
Fig. 3

NOTE: IF PUMP DOES NOT DELIVER FUEL, RECHECK POLARITY OF GROUND TERMINAL.

CAUTION: Gasoline is involved and vapors will settle in low areas, so work in a well-ventilated space away from sparks or open flames such as a pilot light. Have a CLASS "B" fire extinguisher close by. To eliminate the chance of fire or personal injury, the fuel system pressure must be relieved before servicing any fuel system component. Refer to the manufacturer's service manual for specific steps.

WARNING: LIMITED LIFE EXPECTANCY WITH METHANOL. USAGE OF METHANOL VOIDS WARRANTY.

WARNING: THESE PUMPS ARE NOT INTENDED FOR AIRCRAFT USAGE. DO NOT USE PTFE TAPE ON ANY FITTING.

WARNING: FOR SAFETY REASONS, IT IS RECOMMENDED THAT AN A-68301 PRESSURE SAFETY SWITCH BE INSTALLED. This will prevent engine damage and reduce the chance of fire in the case that the engine stops without the ignition switch in the "off" position.

Unless otherwise indicated, parts in this catalog are not intended for use in emission controlled vehicles that must comply with federal, state and/or local emission regulations.

Rotary Vane

(con't from previous page)

Recreational Vehicle – Vapor Lock Installation Instructions

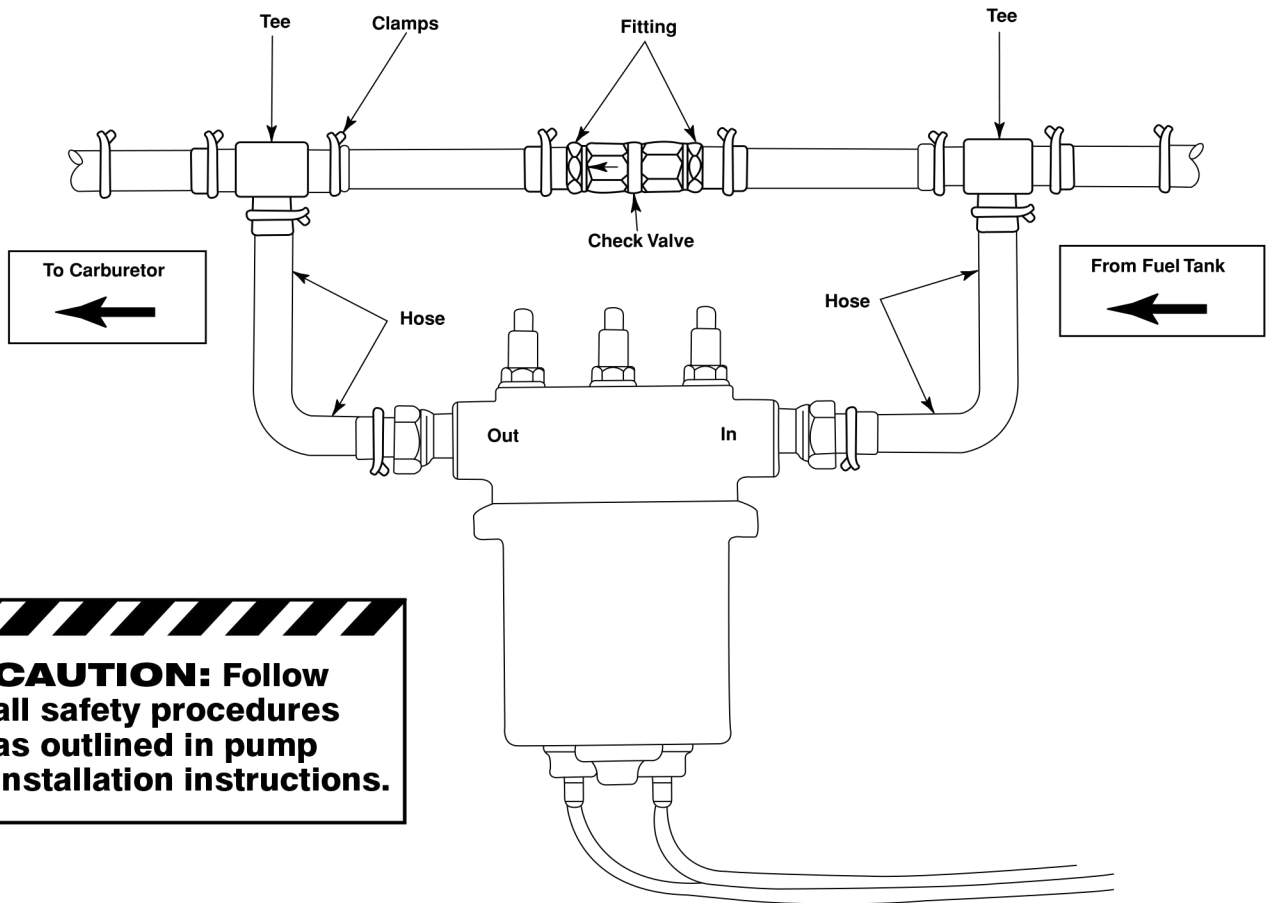

INSTALLATION STEPS

1. Disconnect the negative battery cable.
2. Locate the pump as near to the fuel tank as possible, near the existing fuel line, and away from any exhaust system components.
3. Using the bracket, mount the fuel pump with the outlet toward the engine and the terminals facing downward.
4. Remove a section of fuel line (making sure to collect and store draining gasoline) that will allow the mounting of the supplied tees and check valve. When cutting the line be sure to not allow chips into the inside of the fuel line. (A tubing cutter is recommended.)
5. Assemble the supplied 1/4 NPTF to 3/8" hose connectors into either end of the check valve, using pipe sealant. (Do not use pipe sealant on fitting for pump.)
6. Using 3/8" rubber fuel line (not supplied) and the clamps provided, assemble the tees and check valve to the existing fuel line and then to the fuel pump as illustrated above. Be sure that the arrow on the check valve is pointing toward the engine and in the same direction as the outlet of the fuel pump.
7. Make sure all clamps are secure. Start engine and test for leaks. Repair if necessary.

NOTE: THIS KIT ALLOWS PUMP P4602RV TO BE USED AS A BOOST PUMP. OR CAN BE SHUT OFF BY DRIVER USING AN APPLICABLE TOGGLE SWITCH.

Gerotor

BEFORE YOU BEGIN:

- BEFORE REPLACING ANY ELECTRIC FUEL PUMP, DIAGNOSE THE CAUSE OF FAILURE.
- DIRT IS THE MAJOR CAUSE OF PUMP FAILURE, SO THE TANK MUST BE CLEANED OUT OR DIRT MAY CAUSE THE REPLACEMENT PUMP TO FAIL AS WELL.
- INSTALLATION OF THE REPLACEMENT PUMP MAY REQUIRE THAT SOME OF THE MOUNTING OR ELECTRICAL COMPONENTS BE REUSED. DO NOT DISCARD ANY PARTS.
- TO PREVENT FUEL PUMP FAILURE, INSTALLATION OF A HIGH QUALITY FUEL FILTER ON THE INLET SIDE OF THE PUMP IS REQUIRED.

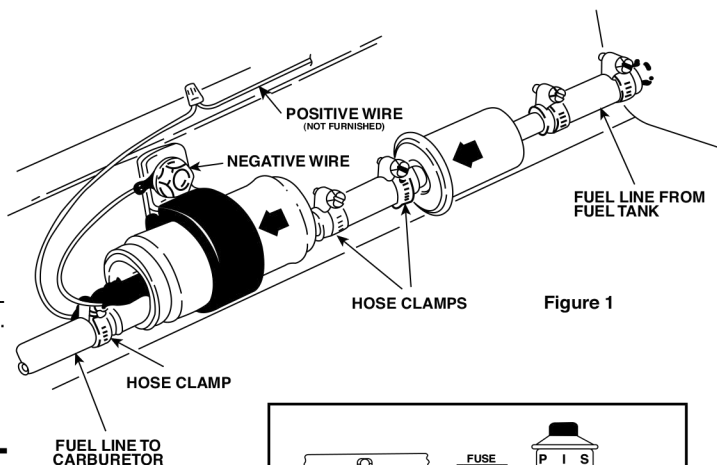

Figure 1

INSTALLATION STEPS

The in-line fuel pump is a pusher type pump, and should be mounted near the fuel tank with the hardware provided.

1. Before installation, disconnect the negative battery cable to eliminate the possibility of arcing.
2. When using an in-line pump to replace a mechanical pump, disconnect lines from the mechanical pump, and connect them together in a suitable manner, thus bypassing the pump. Make sure all connections are tight, as they will be under pressure. A leak in this area will result in a dangerous situation. The outlet port of the mechanical fuel pump should be sealed to eliminate excess pressure on the camshaft. If the mechanical fuel pump is removed from the engine, a suitable plate and gasket must be used to block off the opening to prevent an oil leak. This unit must not be used to force fuel through a defective mechanical pump, since fuel leakage and/or crankcase dilution might result.
3. Select mounting location on the frame or other firm body member no more than 24" above the bottom of the fuel tank, away from all moving parts, exhaust system, and excessive road splash. Do not mount the pump in the trunk. It is imperative that a good quality in-line filter be used on the inlet side of the pump (between the fuel tank and the pump). (See Figure 1.) A new filter is supplied with this pump. **Failure to use a filter will void warranty.**
4. Remove a section of fuel line using a tubing cutter, taking care not to allow chips or foreign matter to contaminate the fuel lines. Cap lines to prevent fuel leakage and possible fire during installation.

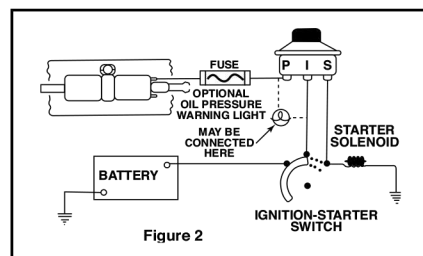

Figure 2

5. Drill a 1/4" hole and loosely mount bracket to vehicle, using screw provided. Install the pump on the bracket, making sure the arrow indicating flow direction is pointing toward the carburetor. Tighten screw and connect pump and filter to fuel lines, using hose and clamps provided.
6. Install provided spade terminals onto both ground and positive wires. Wires should be a minimum of 16 gauge. Connect the ground wire to the negative (-) terminal on the pump. Connect the other end of the ground wire to the provided ring terminal. Connect the ring terminal to a suitable ground such as the mounting bracket screw. Connect the positive wire to the positive (+) terminal on the pump. Positive wire must be long enough to run to the power source or oil pressure switch (see Figure 2). A 5-amp in-line fuse should be used at the power connection. When routing the positive wire, be sure to anchor it securely at frequent intervals to prevent damage and protect it from sharp edges and moving parts.
7. After installation is complete, check all connections for fuel leakage and repair as necessary. Fuel leaks are both dangerous and can cause poor pump performance.

CAUTION: Gasoline is involved and vapors will settle in low areas, so work in a well-ventilated space away from sparks or open flames such as a pilot light. Have a CLASS "B" fire extinguisher close by. To eliminate the chance of fire or personal injury, the fuel system pressure must be relieved before servicing any fuel system component. Refer to the manufacturer's service manual for specific steps.

WARNING: LIMITED LIFE EXPECTANCY WITH METHANOL. USAGE OF METHANOL VOIDS WARRANTY.

WARNING: THESE PUMPS ARE NOT INTENDED FOR AIRCRAFT USAGE. DO NOT USE PTFE TAPE ON ANY FITTING.

WARNING: FOR SAFETY REASONS, IT IS RECOMMENDED THAT AN A-68301 PRESSURE SAFETY SWITCH BE INSTALLED.

This will prevent engine damage and reduce the chance of fire in the case that the engine stops without the ignition switch in the "off" position.

Unless otherwise indicated, parts in this catalog are not intended for use in emission controlled vehicles that must comply with federal, state and/or local emission regulations.

Solenoid

BEFORE YOU BEGIN:

- BEFORE REPLACING ANY ELECTRIC FUEL PUMP, DIAGNOSE THE CAUSE OF FAILURE.
- DIRT IS THE MAJOR CAUSE OF PUMP FAILURE, SO THE TANK MUST BE CLEANED OUT OR DIRT MAY CAUSE THE REPLACEMENT PUMP TO FAIL AS WELL.
- INSTALLATION OF THE REPLACEMENT PUMP MAY REQUIRE THAT SOME OF THE MOUNTING OR ELECTRICAL COMPONENTS BE REUSED. DO NOT DISCARD ANY PARTS.
- TO PREVENT FUEL PUMP FAILURE, INSTALLATION OF A HIGH QUALITY FUEL FILTER ON THE INLET SIDE OF THE PUMP IS REQUIRED.

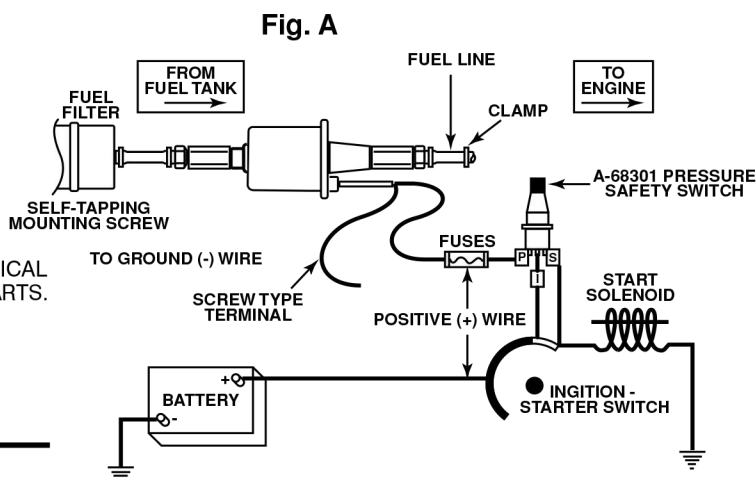

INSTALLATION STEPS

1. Disconnect the negative battery cable.
2. Mount the fuel pump close to the existing fuel lines and tank, but away from any exhaust system component. Place the pump and bracket assembly as near to the bottom of the fuel tank as possible, but never more than 24 inches above the top of the tank.
3. Remove a section of fuel line where the pump is to be mounted. (A tube cutter is recommended when cutting fuel lines. Flush the fuel line to prevent metal chips from entering the fuel system.)
4. If pump has rubber hose fittings, proceed to next step. If using a pump with threaded inlet/outlet fittings, assemble the (supplied) fuel fittings to the fuel pump (see Fig. A). (This pump is equipped with dry-seal fuel fittings. Do not use PTFE tape or pipe sealant on pipe fittings, or pump breakage will occur.)
5. Install mounting bracket onto vehicle's chassis/frame with self-tapping screw(s).
6. Install the fuel pump on the mounting bracket with the outlet towards the engine. Place ground (-) wire from pump under mounting screw or bolt.
7. Connect the fuel lines to the fuel pump, using supplied rubber fuel line and clamps provided. (To prevent fuel pump failure, installation of a high quality fuel filter on the inlet side of the pump is required. See Fig. A.)
8. Using #14 or larger (lower gauge #) gauge wire, follow the wiring diagram (see Fig. A) and connect the pump to the vehicle's electrical system. If the vehicle has a pre-existing oil pressure safety switch which operates either a warning light or gauge, it is recommended that a T-adaptor be installed into the engine block and both the O.E. and the A-68301 Pressure Safety Switch be used. A 10-amp fuse should be installed between the pressure safety switch and the electric pump. (Route wires away from heat and road hazards, and anchor securely to prevent vibration and chafing. Full battery voltage must be available to the pump when the ignition switch is "on." Pump ground must be the same as the battery ground.)
9. If this pump is being used to replace a defective in-tank pump, and it is not going to be removed, make sure the defective pump does not restrict the fuel supply.
10. If this pump is being used to replace a defective mechanical pump, the fuel lines should bypass the mechanical pump. Fuel pushed through a defective mechanical pump can cause severe engine damage. If the mechanical pump is not removed from the engine, the mechanical pump inlet should be plugged.

CAUTION: Gasoline is involved and vapors will settle in low areas, so work in a well-ventilated space away from sparks or open flames such as a pilot light. Have a CLASS "B" fire extinguisher close by. To eliminate the chance of fire or personal injury, the fuel system pressure must be relieved before servicing any fuel system component. Refer to the manufacturer's service manual for specific steps.

WARNING: LIMITED LIFE EXPECTANCY WITH METHANOL. USAGE OF METHANOL VOIDS WARRANTY.

WARNING: THESE PUMPS ARE NOT INTENDED FOR AIRCRAFT USAGE. DO NOT USE PTFE TAPE ON ANY FITTING.

WARNING: FOR SAFETY REASONS, IT IS RECOMMENDED THAT AN A-68301 PRESSURE SAFETY SWITCH BE INSTALLED.

This will prevent engine damage and reduce the chance of fire in the case that the engine stops without the ignition switch in the "off" position.

Unless otherwise indicated, parts in this catalog are not intended for use in emission controlled vehicles that must comply with federal, state and/or local emission regulations.