

Save This Manual  
For Future Reference

**SEARS**

*owners  
manual*

**MODEL NO.  
113.226640**

**SAW WITH LEGS AND  
TWO TABLE EXTENSIONS**

Serial  
Number \_\_\_\_\_

Model and serial  
number may be found  
at the rear of the base.

You should record both  
model and serial number  
in a safe place for  
future use.

**CAUTION:**

**READ ALL  
INSTRUCTIONS  
CAREFULLY**

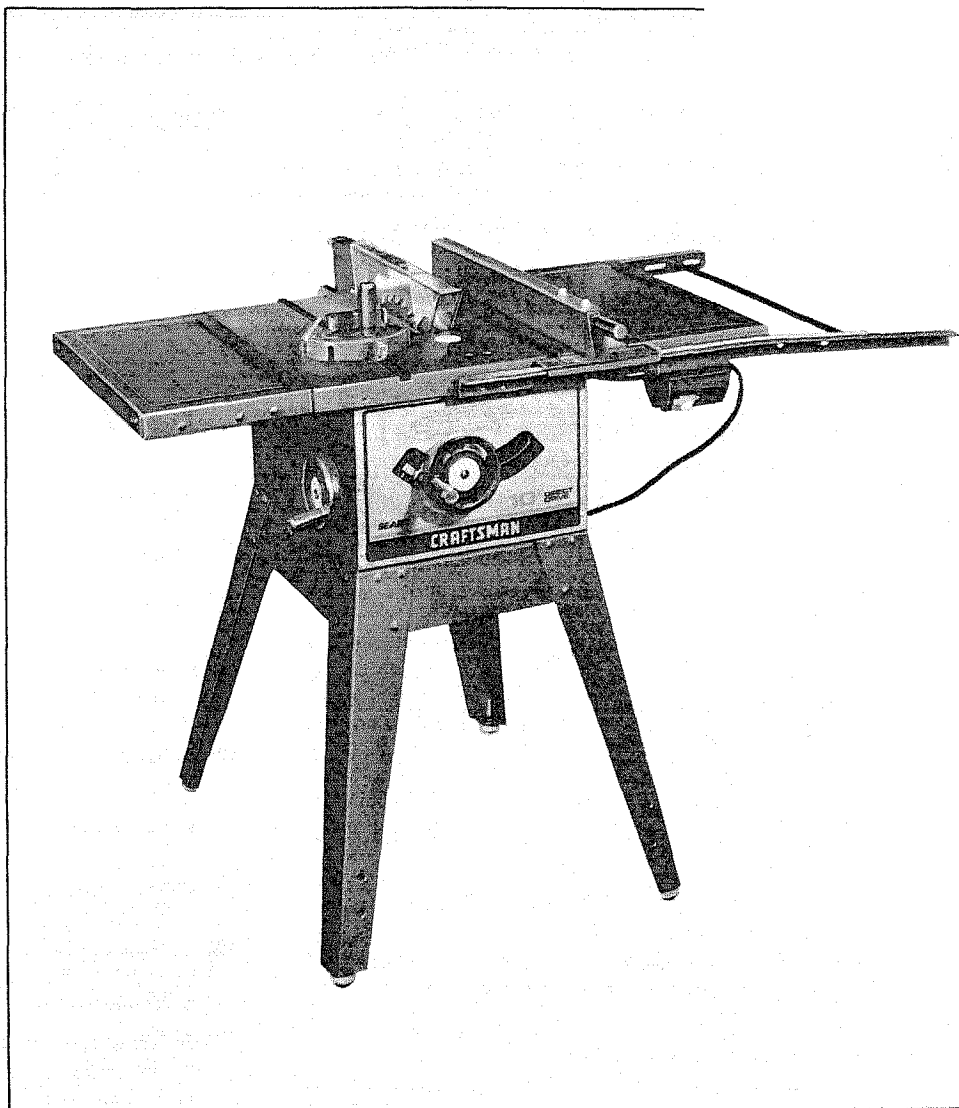

**CRAFTSMAN**

**10-INCH  
DIRECT DRIVE  
TABLE SAW**

- *assembly*
- *operating*
- *repair parts*

**Sold by SEARS, ROEBUCK AND CO., Chicago, IL. 60684 U.S.A.**

Part No. 62969

## FULL ONE YEAR WARRANTY ON CRAFTSMAN TABLE SAW

If within one year from the date of purchase, this Craftsman Table Saw fails due to a defect in material or workmanship, Sears will repair it, free of charge.

WARRANTY SERVICE IS AVAILABLE BY SIMPLY CONTACTING THE NEAREST SEARS SERVICE CENTER/DEPARTMENT THROUGHOUT THE UNITED STATES.

This warranty applies only while this product is in use in the United States.

This warranty gives you specific legal rights, and you may also have other rights which vary from state to state.

SEARS, ROEBUCK AND CO., Dept. 698/731A, Sears Tower, Chicago, IL 60684

## GENERAL SAFETY INSTRUCTIONS FOR POWER TOOLS

### 1. KNOW YOUR POWER TOOL

Read and understand the owner's manual and labels affixed to the tool. Learn its application and limitations as well as the specific potential hazards peculiar to this tool.

### 2. GROUND ALL TOOLS

This tool is equipped with an approved 3-conductor cord and a 3-prong grounding type plug to fit the proper grounding type receptacle. The green conductor in the cord is the grounding wire. Never connect the green wire to a live terminal.

### 3. KEEP GUARDS IN PLACE

in working order, and in proper adjustment and alignment.

### 4. REMOVE ADJUSTING KEYS AND WRENCHES

Form habit of checking to see that keys and adjusting wrenches are removed from tool before turning it on.

### 5. KEEP WORK AREA CLEAN

Cluttered areas and benches invite accidents. Floor must not be slippery due to wax or sawdust.

### 6. AVOID DANGEROUS ENVIRONMENT

Don't use power tools in damp or wet locations or expose them to rain. Keep work area well lighted. Provide adequate surrounding work space.

### 7. KEEP CHILDREN AWAY

All visitors should be kept a safe distance from work area.

### 8. MAKE WORKSHOP CHILD-PROOF

— with padlocks, master switches, or by removing starter keys.

### 9. DON'T FORCE TOOL

It will do the job better and safer at the rate for which it was designed.

### 10. USE RIGHT TOOL

Don't force tool or attachment to do a job it was not designed for.

### 11. WEAR PROPER APPAREL

Do not wear loose clothing, gloves, neckties or jewelry (rings, wrist watches) to get caught in moving parts. Nonslip footwear is recommended. Wear protective hair covering to contain long hair. Roll long sleeves above the elbow.

### 12. USE SAFETY GOGGLES (Head Protection)

Wear Safety goggles (must comply with ANSI

Z87.1) at all times. Everyday eyeglasses only have impact resistant lenses, they are NOT safety glasses. Also, use face or dust mask if cutting operation is dusty, and ear protectors (plugs or muffs) during extended periods of operation.

### 13. SECURE WORK

Use clamps or a vise to hold work when practical. It's safer than using your hand, frees both hands to operate tool.

### 14. DON'T OVERREACH

Keep proper footing and balance at all times.

### 15. MAINTAIN TOOLS WITH CARE

Keep tools sharp and clean for best and safest performance. Follow instructions for lubricating and changing accessories.

### 16. DISCONNECT TOOLS

before servicing; when changing accessories such as blades, bits, cutters, etc.

### 17. AVOID ACCIDENTAL STARTING

Make sure switch is in "OFF" position before plugging in.

### 18. USE RECOMMENDED ACCESSORIES

Consult the owner's manual for recommended accessories. Follow the instructions that accompany the accessories. The use of improper accessories may cause hazards.

### 19. NEVER STAND ON TOOL

Serious injury could occur if the tool is tipped or if the cutting tool is accidentally contacted.

Do not store materials above or near the tool such that it is necessary to stand on the tool to reach them.

### 20. CHECK DAMAGED PARTS

Before further use of the tool, a guard or other part that is damaged should be carefully checked to ensure that it will operate properly and perform its intended function. Check for alignment of moving parts, binding of moving parts, breakage of parts, mounting, and any other conditions that may affect its operation. A guard or other part that is damaged should be properly repaired or replaced.

### 21. DIRECTION OF FEED

Feed work into a blade or cutter against the direction of rotation of the blade or cutter only.

### 22. NEVER LEAVE TOOL RUNNING UNATTENDED

Turn power off. Don't leave tool until it comes to a complete stop.

# ADDITIONAL SAFETY INSTRUCTIONS FOR TABLE SAWS

**WARNING: FOR YOUR OWN SAFETY, DO NOT OPERATE YOUR SAW UNTIL IT IS COMPLETELY ASSEMBLED AND INSTALLED ACCORDING TO THE INSTRUCTIONS ... AND UNTIL YOU HAVE READ AND UNDERSTAND THE FOLLOWING.**

1. GENERAL SAFETY INSTRUCTIONS FOR POWER TOOLS ... SEE PAGE 2
2. GETTING TO KNOW YOUR SAW ... SEE PAGE 20.
3. BASIC SAW OPERATION ... SEE PAGE 23.
4. MAINTENANCE ... SEE PAGE 32.
5. STABILITY OF SAW

If there is any tendency for the saw to tip over or move during certain cutting operations such as cutting extremely large heavy panels or long heavy boards, the saw should be bolted down. If you attach any kind of table extensions over 24" wide to either end of the saw, make sure you either bolt the saw to the bench or floor as appropriate, or support the outer end of the extension from the bench or floor, as appropriate.

## 6. LOCATION

The saw should be positioned so neither the operator nor a casual observer is forced to stand in line with the saw blade.

## 7. KICKBACKS

A "KICKBACK" occurs during a rip-type operation when a part or all of the workpiece is thrown back violently toward the operator.

Keep your face and body to one side of the sawblade, out of line with a possible "Kickback." Kickbacks — and possible injury from them — can usually be avoided by:

- A. Maintaining the rip fence parallel to the sawblade.
- B. Keeping the sawblade sharp. Replace or sharpen antikickback pawls when points become dull.
- C. Keeping sawblade guard, spreader, and antikickback pawls in place and operating properly. The spreader must be in alignment with the sawblade and the pawls must stop a kickback once it has started.  
*Check their action before ripping.*
- D. NOT ripping work that is twisted or warped or does not have a straight edge to guide along the rip fence.
- E. NOT releasing work until you have pushed it all the way past the sawblade.
- F. Using a push stick for ripping widths of 2 to 6 in., and an auxiliary fence and push block for ripping widths narrower than 2 in. (See "Basic Saw Operation Using The Rip Fence" section.)
- G. NOT confining the cut-off piece when ripping or cross-cutting.
- H. When ripping apply the feed force to the section of the workpiece between the saw blade and the rip fence.

## 8. PROTECTION: EYES, HANDS, FACE, EARS, BODY

- A. If any part of your saw is malfunctioning, has been damaged or broken ... such as the motor switch, or other operating control, a safety device or the power cord ... cease

operating immediately until the particular part is properly repaired or replaced.

- B. Small loose pieces of wood or other objects that contact the rear of the revolving blade can be thrown back at the operator at excessive speed. This can usually be avoided by keeping the guard and spreader in place for all thru-sawing operations (sawing entirely thru the work) AND by removing all loose pieces from the table with a long stick of wood IMMEDIATELY after they are cut off.
- C. Use extra caution when the guard assembly is removed for resawing, dadoing, rabbeting, or molding — replace the guard as soon as that operation is completed.
- D. For rip or rip-type cuts, the following end of a workpiece to which a push stick or push board is applied must be square (perpendicular to the fence) in order that feed pressure applied to the workpiece by the push stick or block does not cause the workpiece to come away from the fence, and possibly cause a kickback.
- E. During rip and rip type cuts, the workpiece must be held down on the table and against the fence with a push stick, push block, or featherboards. A featherboard is made of solid lumber per sketch.

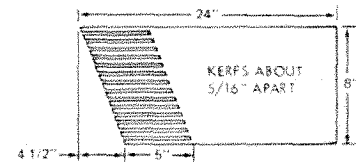

- F. NEVER turn the saw "ON" before clearing the table of all tools, wood scraps, etc., except the workpiece and related feed or support devices for the operation planned.
- G. NEVER place your face or body in line with the cutting tool.
- H. NEVER place your fingers or hands in the path of the sawblade or other cutting tool.
- I. NEVER reach in back of the cutting tool with either hand to hold down or support the workpiece, remove wood scraps, or for any other reason. Avoid awkward operations and hand positions where a sudden slip could cause fingers or hand to move into a sawblade or other cutting tool.
- J. DO NOT perform layout, assembly, or setup work on the table while the cutting tool is rotating.
- K. DO NOT perform any operation "FREEHAND" — always use either the rip fence or the miter gauge to position and guide the work.
- L. NEVER use the rip fence when crosscutting or the miter gauge when ripping. DO NOT use the rip fence as a length stop. Never hold onto or touch the "free end" of the workpiece or a "free piece" that is cut off, while power is "ON" and/or the sawblade is rotating.
- M. Shut "OFF" the saw and disconnect the power cord when removing the table insert, changing the cutting tool, removing or replacing the blade guard, or making adjustments.

- N. Provide adequate support to the rear and sides of the saw table for wider or long workpieces.
- O. Plastic and composition (like hardboard) materials may be cut on your saw. However, since these are usually quite hard and slippery, the antikickback pawls may not stop a kickback.  
Therefore, be especially attentive to following proper set-up and cutting procedures for ripping. Do not stand, or permit anyone else to stand, in line with a potential kickback.
- P. If you stall or jam the sawblade in the workpiece, turn saw "OFF", remove the workpiece from the sawblade and check to see if the sawblade is parallel to the miter gauge grooves and if the spreader is in proper alignment with the sawblade. If ripping at the time, check to see if the rip fence is parallel with the sawblade. Readjust as indicated.
- Q. DO NOT remove small pieces of cut-off material that may become trapped inside the blade guard while the saw is running. This could endanger your hands or cause a kickback. Turn saw "OFF" and wait until blade stops.
- R. Use extra care when ripping wood that has a twisted grain or is twisted or bowed — it may rock on the table and/or pinch the sawblade.

**9. KNOW YOUR CUTTING TOOLS**

- A. Dull, gummy, or improperly sharpened or set cutting tools can cause material to stick, jam, stall the saw, or kickback at the operator. Minimize potential injury by proper cutting tool and machine maintenance.  
NEVER ATTEMPT TO FREE A STALLED SAWBLADE WITHOUT FIRST TURNING THE SAW OFF.
- B. Never use grinding wheels, abrasive cut-off wheels, friction wheels (metal slitting blades) wire wheels or buffing wheels.

**10. USE ONLY ACCESSORIES DESIGNED FOR THIS SAW.**

- 11. Crosscutting operations are more conveniently worked and with greater safety if an auxiliary wood facing is attached to the miter gauge using the holes provided. However, the facing must not interfere with the proper functioning of the sawblade guard.
- 12. Make sure the top of the arbor or cutting tool rotates toward you when standing in normal operating position. Also make sure the cutting tool, arbor collars and arbor nut are installed properly. Keep the cutting tool as low as possible for the operation being performed. Keep all guards in place whenever possible.
- 13. Do not use any blade or other cutting tool marked for an operating speed less than 3450 RPM. Never use a cutting tool larger in diameter than the diameter for which the saw was designed. For greatest safety and efficiency

when ripping, use the maximum diameter blade for which the saw is designed, since under these conditions the spreader is nearest the blade.

- 14. Adjust table inserts flush with the table top. NEVER operate the saw unless the proper insert is installed.
- 15. NEVER feed material into the cutting tool from the rear of the saw. An accident and serious injury could result.
- 17. NEVER use another person as a substitute for a table extension, or as additional support for a workpiece that is longer or wider than the basic saw table, or to assist in feeding or supporting or pulling the workpiece.  
DO NOT pull the workpiece through the sawblade - position your body at the nose (in-feed) side of the guard: start and complete the cut from the same side. This will require added table support for long or wide workpieces that extend beyond the length or width of the saw table.
- 18. **THINK SAFETY.**  
Safety is a combination of operator common sense and alertness at all times when the saw is being used.
- 19. **NOTE AND FOLLOW SAFETY INSTRUCTIONS THAT APPEAR ON THE FRONT OF YOUR SAW.**

**DANGER** FOR YOUR OWN SAFETY:

READ AND UNDERSTAND OWNERS MANUAL BEFORE OPERATING MACHINE.

1. WEAR SAFETY GOGGLES.	5. KNOW HOW TO AVOID "KICKBACKS."
2. USE SAWBLADE GUARD FOR "THRU SAWING."	6. DO NOT PERFORM OPERATIONS "FREEHAND."
3. KEEP HANDS OUT OF PATH OF SAWBLADE.	7. NEVER REACH AROUND OR OVER SAWBLADE.
4. USE A "PUSH STICK" WHEN REQUIRED.	

WARNING: USE 120 VOLT, 15 AMP BRANCH CIRCUIT AND USE 15 AMP. TIME DELAY FUSE.

**20. WARNING: DO NOT ALLOW FAMILIARITY (GAINED FROM FREQUENT USE OF YOUR SAW) TO BECOME COMMONPLACE. - ALWAYS REMEMBER THAT A CARELESS FRACTION OF A SECOND IS SUFFICIENT TO INFLECT SEVERE INJURY.**

**NOTE:** Do not overtighten arbor nut. Use the arbor wrench to just "snug" it.



The operation of any power tool can result in foreign objects being thrown into the eyes, which can result in severe eye damage. Always wear safety goggles complying with ANSI Z87.1 (shown on Package) before commencing power tool operation. Safety Goggles are available at Sears retail or catalog stores.



# MOTOR SPECIFICATIONS AND ELECTRICAL REQUIREMENTS

This saw is designed to use a 3450 RPM motor only. Do not use any motor that runs faster than 3450 RPM. It is wired for operation on 110-120 volts, 60 Hz., Alternating current. IT MUST NOT BE CONVERTED TO OPERATE ON 230 VOLTS.

## WARNING

**THE STARTING RELAY IN THIS SWITCH HOUSING IS A GRAVITY SENSITIVE TYPE. NEVER TURN THE POWER ON UNTIL THE SWITCH HOUSING HAS BEEN ASSEMBLED ON THE FRONT FENCE BAR AND THE SAW IS UPRIGHT IN SAWING POSITION.**

## CONNECTING TO POWER SOURCE OUTLET

This saw must be grounded while in use to protect the operator from electrical shock.

If power cord is worn or cut, or damaged in any way, have it replaced immediately.

If your saw is for use on less than 150 volts it has a plug that looks like below.

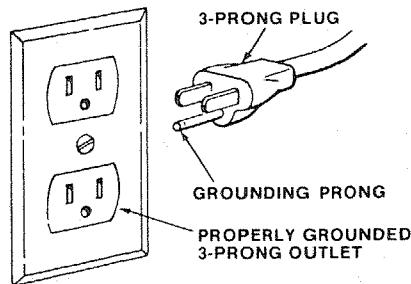

Plug power cord of fully assembled saw into 110-120V properly grounded type outlet protected by a 15-amp. time delay or Circuit-Saver fuse or circuit breaker.

**IF YOU ARE NOT SURE THAT YOUR OUTLET IS PROPERLY GROUNDED, HAVE IT CHECKED BY A QUALIFIED ELECTRICIAN.**

**WARNING: DO NOT PERMIT FINGERS TO TOUCH THE TERMINALS OF PLUG WHEN INSTALLING OR REMOVING THE PLUG TO OR FROM THE OUTLET.**

**WARNING: IF NOT PROPERLY GROUNDED THIS POWER TOOL CAN INCUR THE POTENTIAL HAZARD OF ELECTRICAL SHOCK PARTICULARLY WHEN USED IN DAMP LOCATIONS, IN PROXIMITY TO PLUMBING, OR OUT OF DOORS. IF AN ELECTRICAL SHOCK OCCURS THERE IS THE POTENTIAL OF A SECONDARY HAZARD SUCH AS YOUR HANDS CONTACTING THE SAWBLADE.**

This saw is equipped with a 3-conductor cord and grounding type plug which has a grounding prong, approved by Underwriters' Laboratories and the Canadian Standards Association. The ground conductor has a green lug and is attached to the tool housing at one end and to the ground prong in the attachment plug at the other end.

This plug requires a mating 3-conductor grounded type outlet as shown.

If the outlet you are planning to use for this saw is of the two prong type DO NOT REMOVE OR ALTER THE GROUNDING PRONG IN ANY MANNER. Use an adapter as shown and always connect the grounding lug to a known ground.

It is recommended that you have a qualified electrician replace the TWO prong outlet with a properly grounded THREE prong outlet.

A temporary adapter as shown below is available for connecting plugs to 2-prong receptacles. The green grounding lug extending from the adapter must be connected to a permanent ground such as to a properly grounded outlet box.

A temporary adapter as illustrated is available for connecting plugs to 2-prong receptacles. The temporary adapter should be used only until a properly grounded outlet can be installed by a qualified electrician.

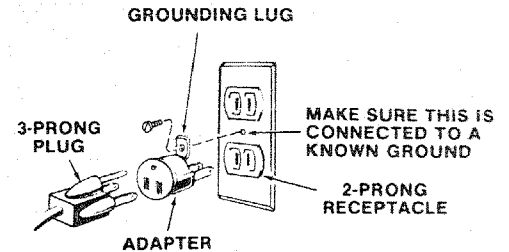

**WARNING: THE GREEN GROUNDING LUG EXTENDING FROM THE ADAPTER MUST BE CONNECTED TO A PERMANENT GROUND SUCH AS TO A PROPERLY GROUNDED OUTLET BOX. NOT ALL OUTLET BOXES ARE PROPERLY GROUNDED.**

If you are not sure that your outlet box is properly grounded, have it checked by a qualified electrician

**NOTE:** The adapter illustrated is for use only if you already have a properly grounded 2-prong receptacle.

The use of any extension cord will cause some loss of power. To keep this to a minimum and to prevent over-heating and motor burn-out, use the table below to determine the minimum wire size (A.W.G.) extension cord. Use only 3 wire extension cords which have 3 prong grounding type plugs and 3 pole receptacles which will accept the plug on the saw.

The motor must rotate COUNTERCLOCKWISE when viewed from the shaft end.

1 H.P. MOTOR 110-120V	
Extension Cord Length	Wire Size A.W.G.
Up to 50 Ft. ....	14
50 to 100 Ft. ....	12
100 - 200 Ft. ....	10
200 - 400 Ft. ....	8



## CONTENTS

WARRANTY .....	2	Miter Gauge .....	21
GENERAL SAFETY INSTRUCTION		Blade Guard .....	22
FOR POWER TOOLS .....	2	Table Insert .....	22
ADDITIONAL SAFETY INSTRUCTIONS		Removing and Installing Sawblade .....	22
FOR TABLE SAWS .....	3	Exacti-Cut .....	22
MOTOR SPECIFICATIONS AND ELECTRICAL		BASIC SAW OPERATION USING THE MITER	
REQUIREMENTS .....	5	GAUGE .....	23
UNPACKING AND CHECKING CONTENTS .....	6	Work Helpers .....	23
Tools Needed .....	6	Using the Miter Gauge .....	24
List of Loose Parts .....	7	Crosscutting .....	24
ASSEMBLY .....	7	Repetitive Cutting .....	25
Assembling Steel Legs .....	7	Miter Cutting .....	26
Mounting Saw .....	8	Bevel Crosscutting .....	26
Installing Handwheels .....	8	Compound Miter Cutting .....	26
Checking Table Insert .....	9	BASIC SAW OPERATION USING THE RIP	
Heeling Adjustment of Parallelism of		FENCE .....	26
Sawblade to Miter Gauge Groove .....	9	Ripping .....	27
Blade Tilt, or Squareness of Blade to Table	10	Bevel Ripping .....	27
Blade Elevation .....	12	Cutting Panels .....	29
Tilt and Elevation Mechanism .....	12	Ploughing and Molding .....	29
Attaching Table Extensions .....	12	Resawing .....	30
Installing Rip Fence Guide Bars and Switch	13	Rabbeting .....	30
Aligning Rip Fence .....	16	Dadoing .....	30
Adjusting Rip Scale Indicator .....	17	Molding Cutting .....	31
Installing Blade Guard .....	18	Using Featherboards .....	31
Adjusting Miter Gauge .....	20	MOTOR .....	31
GETTING TO KNOW YOUR SAW .....	20	MAINTENANCE .....	32
On-Off Switch .....	20	LUBRICATION .....	32
Elevation Handwheel .....	21	RECOMMENDED ACCESSORIES .....	33
Tilt Handwheel .....	21	TROUBLE SHOOTING .....	33
Rip Fence .....	21	REPAIR PARTS .....	36

## UNPACKING AND CHECKING CONTENTS

### TOOLS NEEDED



Hammer



Medium Screwdriver  
Small Screwdriver



Pliers



#2 Phillips Screwdriver

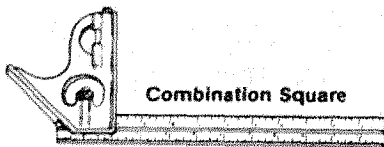

Combination Square



Wrenches  
3/8 in. 7/16 in.  
1/2 in. 9/16 in.  
3/4 in.

### COMBINATION SQUARE MUST BE TRUE.

DRAW LIGHT LINE ON BOARD ALONG THIS EDGE.  
STRAIGHT EDGE OF BOARD 3/4" THICK. THIS EDGE MUST BE PERFECTLY STRAIGHT.

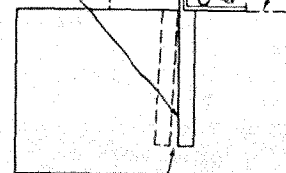

SHOULD BE NO GAP OR OVERLAP HERE WHEN SQUARE IS FLIPPED OVER IN DOTTED POSITION.

Model 113.226640 Table Saw is shipped complete in one carton.

Separate all parts from packing materials and check each one with the illustration and the list of Loose Parts to make certain all items are accounted for, before discarding any packing material.

If any parts are missing, do not attempt to assemble the table saw, plug in the power cord or turn the switch on until the missing parts are obtained and are installed correctly.

Remove the protective oil that is applied to the table top and edges of the table. Use any ordinary household type grease and spot remover.

**CAUTION: To avoid fire or health hazard never use gasoline, naphtha or similar highly volatile solvents.**

Apply a coat of automobile wax to the table.

Wipe all parts thoroughly with a clean, dry cloth.

**WARNING: FOR YOUR OWN SAFETY, NEVER CONNECT PLUG TO POWER SOURCE OUTLET UNTIL ALL ASSEMBLY STEPS ARE COMPLETE, AND YOU HAVE READ AND UNDERSTAND THE SAFETY AND OPERATIONAL INSTRUCTIONS.**

## LIST OF LOOSE PARTS

Item	Part Name	Qty.	Item	Part Name	Qty.
A	Miter Gauge	1	DD	Nut, Sq. 1/4-20	2
B	Rip Fence	1		*Bag of Loose Parts (Part No. 62978)	2
C	Blade Guard and Spreader	2		Consisting of:	
D	Handwheel	1	EE	Bracket, Corner Support	2
E	Rip Fence Guide Bar, Rear	1	FF	Bracket, Corner Stiffener	2
F	Rip Fence Guide Bar Rod	1		Bag of Loose Parts (Part No. 62980)	1
G	Extension, Table	2		Consisting of:	
H	Leg	4	R	Nut, Jam 5/16-18	3
J	Stiffener Side	2	S	Nut, Hex 1/4-20	8
K	Stiffener End	2	T	Screw, Truss Hd. 1/4-20 x 1	8
L	Rip Fence Guide Bar with Rip Scale (Front)	1	U	Lockwasher, External 1/4	8
M	Owners Manual	1	U	Lockwasher, External 5/16	3
	Bag of Loose Parts (Part No. 62982)	1	GG	Screw, Hex 5/16-18 x 1-1/4	3
	Consisting of:		HH	Washer, 11/32 x 11/16 x 1/16	3
N	Wrench, Shaft	1	HH	Washer, 17/64 x 3/4 x 1/16	2
P	Wrench, Arbor	1		*Bag of Loose Parts (Part No. 62981)	1
LL	Pointer, Bevel	1		Consisting of:	
	*Bag of Loose Parts (Part No. 62767)	1	R	Nut, Hex Jam 5/16-18	2
	Consisting of:		S	Nut, Hex 1/4-20	2
Q	Foot, Leveling	4	U	Lockwasher, External 5/16	4
R	Nut, Hex Jam 1/2-13	8	GG	Screw, Hex 5/16-18 x 1-1/2	2
S	Nut, Hex 1/4-20	24	GG	Screw, Hex 5/16-18 x 1	2
T	Screw, Truss Hd. 1/4-20 x 5/8	24	HH	Washer, 17/64 x 9/16 x 3/64	4
U	Lockwasher, External 1/4	24	HH	Washer, 21/64 x 5/8 x 1/16	4
	*Bag of Loose Parts (Part No. 62984)	1	JJ	Spacer, Fence Guide Bar	2
	Consisting of:			*Bag of Loose Parts (Part No. 507421)	
V	Clamp, Spreader	1		Consisting of:	
W	Bracket	1	S	Nut, Hex 5/16-18	2
	Bag of Loose Parts (Part No. 62983)	1	S	Nut, Hex 1/4-20	4
	Consisting of:		T	Screw, Truss Hd. 1/4-20 x 5/8	4
T	Screw, Truss Hd. 1/4-20 x 5/8	2	U	Lockwasher, External 5/16	4
U	Lockwasher, External #10	2	U	Lockwasher, External 1/4	8
X	Support, Spreader	1	AA	Screw, Pan Hd. Type "T" No. 8 x 3/8	1
Y	Wrench, Hex "L" 3/16	1	GG	Screw, Hex Hd. 5/16-18 x 3/4	2
Y	Wrench, Hex "L" 1/8	1	HH	Washer, 17/64 x 5/8 x 1/16	8
Z	Key, Switch	1	KK	Nut, Self Threading	2
AA	Screw, Pan Hd. 10-32 x 3/4	2		*These Bags are in Bag of Loose Parts No. 62982	
BB	Screw, Soc. Set 1/4-20 x 7/8	2			
CC	Nut, Wing 1/4-20	2			

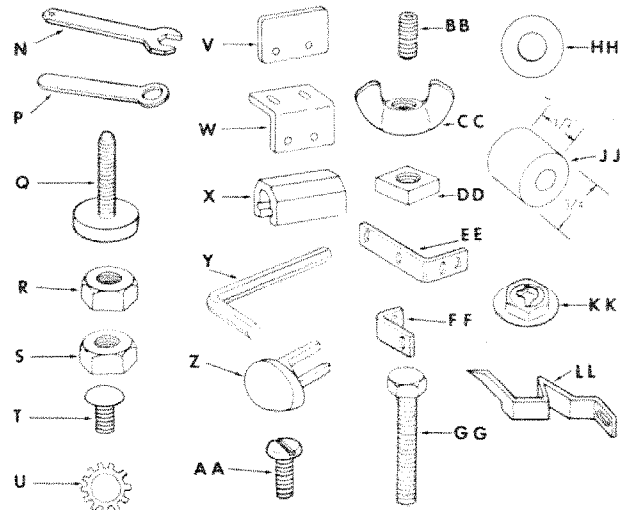
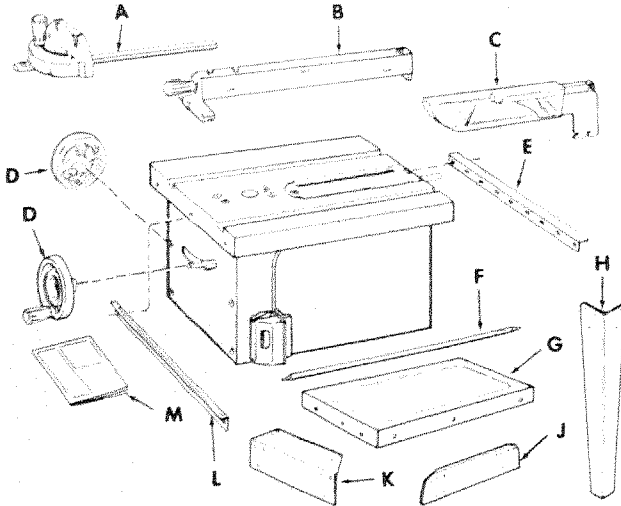

## ASSEMBLY

### ASSEMBLY OF STEEL LEG SET

Assembly is best done in the location where the saw will be stationed and used.

If the saw you purchased is furnished with a leg set, follow the instructions below for easy assembly.

1. Locate the following:

Description	Qty.
Steel Legs	4
Side Stiffeners	2
End Stiffeners	2
Leveling Feet	4
Hex Nuts, 1/2-13	8
Truss Head Screws, 1/4-20 x 5/8"	24
Hex Nuts, 1/4-20	24
1/4 I.D. External Lockwashers	24

- Insert three truss head screws through the three holes near the top of one leg. Place the side stiffener up to the leg as shown so that the three screws line up with the holes in the side stiffeners marked with an "X" in the illustration.
- Place a lockwasher and a hex nut on each screw and finger tighten the hex nut.
- Following the same procedure as above, continue to fasten together the remaining legs and stiffeners as illustrated.
- Install one hex nut, 1/2-13, on each of the leveling feet.
- Insert each leveling foot through the hole in the bottom of each leg so the leveling foot pad rests on the floor.
- Install another hex nut 1/2-13 on each of the leveling feet.
- After complete assembly, you may level the saw by moving the lower nut up or down along the threaded stud of each leveling foot. The upper nut is used to lock the leveling foot into position when the saw is level.

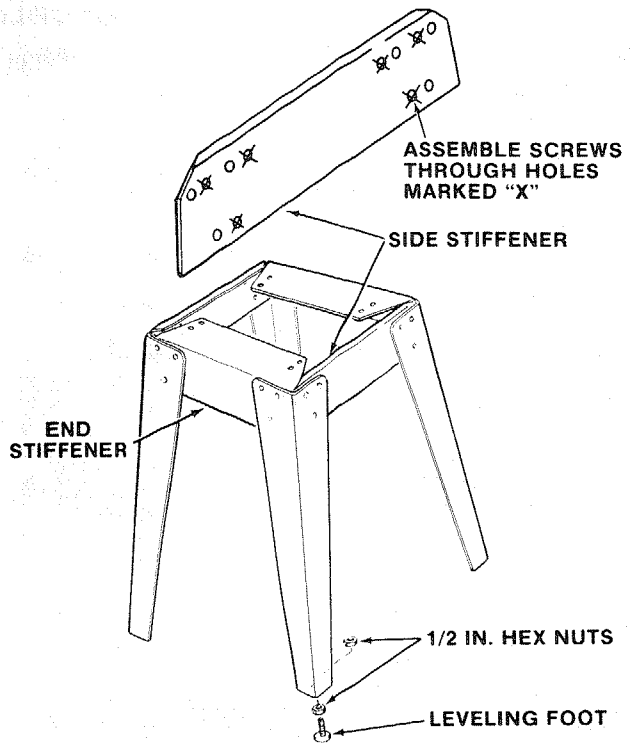

## MOUNTING YOUR SAW TO THE LEG SET

- Locate the following hardware from one of the bags containing loose parts.

Description	Qty
Truss Head Screws, 1/4-20 x 5/8	4
Hex Nuts, 1/4-20	4
1/4 I.D. External Lockwashers	4
11/32 I.D. Flat Washers	8

- Place the saw on top of the leg set so that the base of the saw lines up approximately even with the outline of the top of the leg set.
- From beneath the saw you will be able to locate and line up the four mounting holes of the saw base with the proper mounting holes in the leg set assembly.
- Place one flat washer onto each of the four hex head screws and insert them into each of the mounting holes. Be sure the screws go through the saw base holes and the leg set mounting holes.

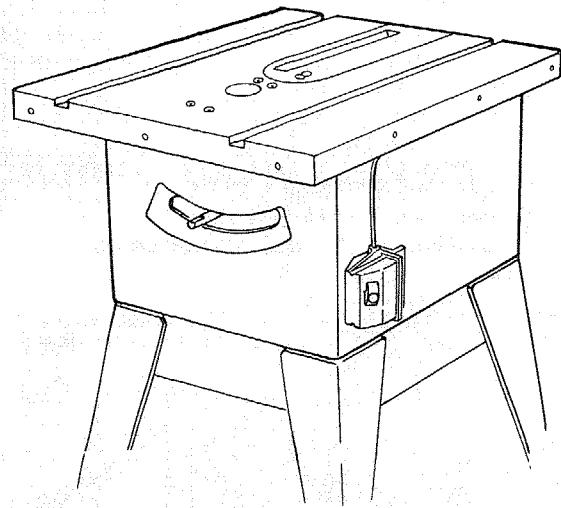

- Install a flat washer, lockwasher, and a hex nut on each of the four screws and tighten securely.
- Level the saw to your requirements by adjusting the leveling feet. Lock leveling feet into position.
- Securely tighten all leg set screws and nuts.

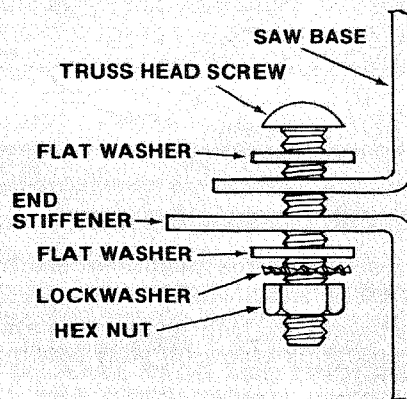

## INSTALLING BEVEL POINTER AND HANDWHEELS

Locate the following parts

Bevel Pointer .....	1
Screw, 8-32 x 3/8 .....	1
Handwheels .....	2
Screw, Phillips 10-32 x 3/4 .....	2
Lockwashers, 3/16 I.D. External .....	2

1. Fasten bevel pointer to cradle assembly with 8-32 x 3/4 in screw, as shown. Adjustment of the pointer may be necessary later.
2. Push handwheels onto shafts as shown and fasten each with a 10-32 x 3/4 in. screw and lockwasher.

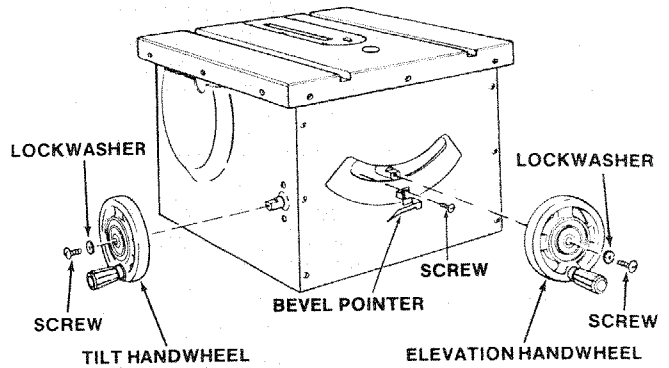

## CHECKING AND ADJUSTING THE TABLE INSERT

The table insert must be flush with the surface of the saw table to keep the workpiece from hanging up or binding with the sawblade as the workpiece is cut by the sawblade.

1. Lower sawblade beneath the table insert and check to be sure the screw fastening the insert in place is snug.
2. Use a straight edge to check near each of the eight leveling tab positions to determine if the insert is flush with the surface of the saw table at all eight leveling tab positions.
3. If insert is not flush with table surface loosen insert fastening screw and pull insert forward to lift from saw table.
4. Bend tabs with pliers or tap with a hammer as required to make the insert flush with the table top.

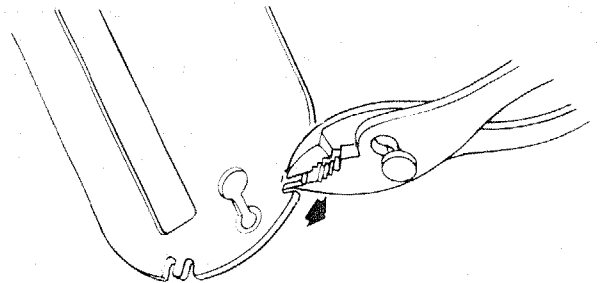
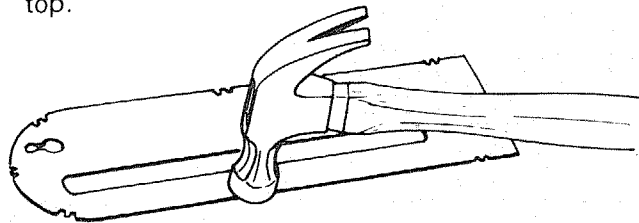
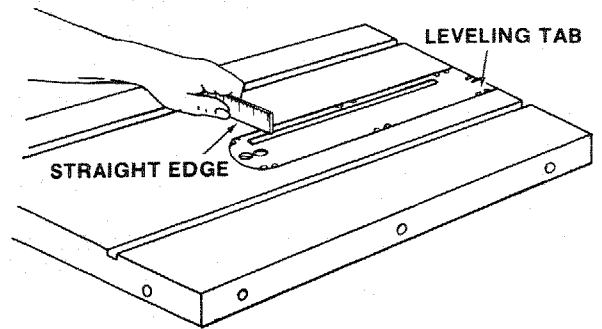

## HEELING ADJUSTMENT OR PARALLELISM OF THE SAWBLADE TO THE MITER GAUGE GROOVE

The workpiece being cut must always move in a straight line parallel to the sawblade. Therefore, both the miter gauge groove and the rip fence must always be parallel with the sawblade.

If the sawblade is NOT parallel with the miter gauge groove and the rip fence, the workpiece will bind at one end of the cut. This is known as "heeling".

**WARNING: For your own safety, turn switch "OFF" and remove plug from power source outlet.**

1. Raise blade to highest elevation.
2. Lift blade guard, if already installed, to highest position.
3. Use chalk or another suitable marker to mark an "X" on one of the teeth of the sawblade which is naturally bent to the left.

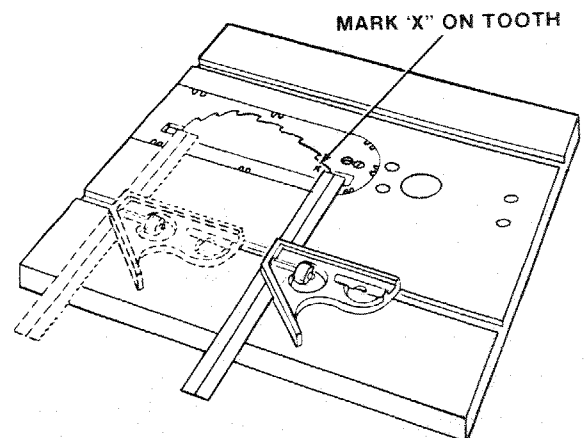

4. Using an accurate combination square, place the head of the square in the miter gauge groove and adjust the ruler blade of the square so that the end of the blade just touches the side of the tooth you marked on the sawblade. Remember to keep the head of the square flush against the miter gauge groove.

5. Rotate the sawblade so that the "X" on the tooth is now visible at the rear of the saw.

6. Move the combination square to the rear of the saw and the end of the square blade should just touch the marked tooth the same as it did at the front of the sawblade.

7. If sawblade does not appear to be parallel with the miter gauge groove you must adjust the position of the sawblade by loosening the four adjustment locking screws about 1/2 turn.

8. Loosen two pan head screws, 10-32, on the rear skirt of the table about 1/2 turn.

9. The mechanism under the table can now be moved sideways from above by covering the sawblade with a piece of cardboard and shifting the blade to the right or left as required.

10. After shifting the sawblade mechanism slightly, recheck the position of the marked tooth of the sawblade at both front and rear.

11. The tooth marked on the sawblade should be parallel to the miter gauge groove after adjustment is made.

12. Tighten all screws carefully so as not to move sawblade out of alignment.

13. Recheck parallelism of marked sawblade tooth to the miter gauge groove. Repeat the steps for heeling adjustment if necessary.

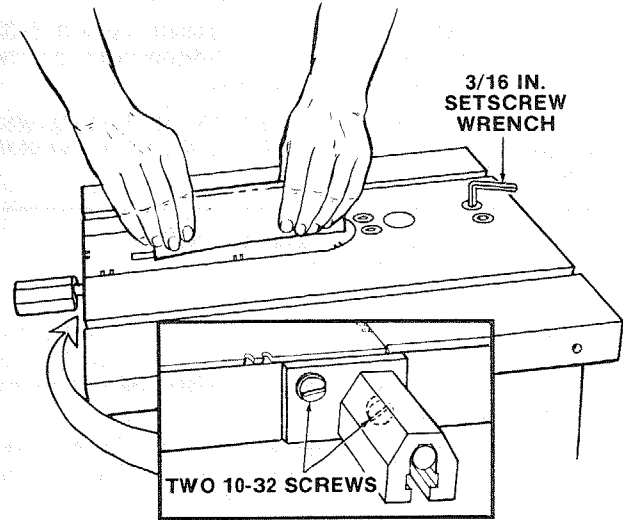

### BLADE TILT, OR SQUARENESS OF BLADE TO TABLE

90° (SQUARE) and 45° (BEVEL) STOP COLLARS. When the bevel pointer is pointing directly to the "O" mark on the bevel scale, the sawblade should make a SQUARE cut 90° to the table.

To check for SQUARENESS:

**WARNING: FOR YOUR OWN SAFETY, TURN SWITCH "OFF" AND REMOVE PLUG FROM POWER SOURCE OUTLET.**

1. Raise blade all the way UP . . . raise blade guard.
2. TILT blade a few degrees to the LEFT . . . now tilt blade back to the RIGHT as far as it will go.
3. Place the square against blade. Make sure square is not touching the TIP of one of the saw TEETH.

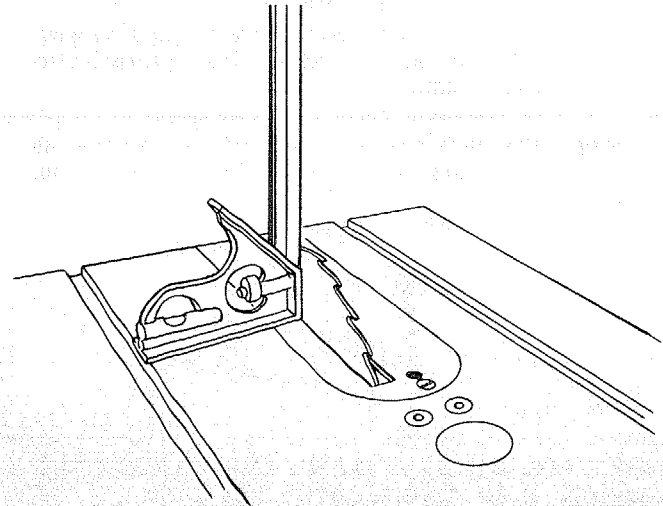

If blade IS SQUARE to table; Check pointer  
If POINTER DOES NOT point to the "O" mark on the bevel scale; Bend pointer to read "O".

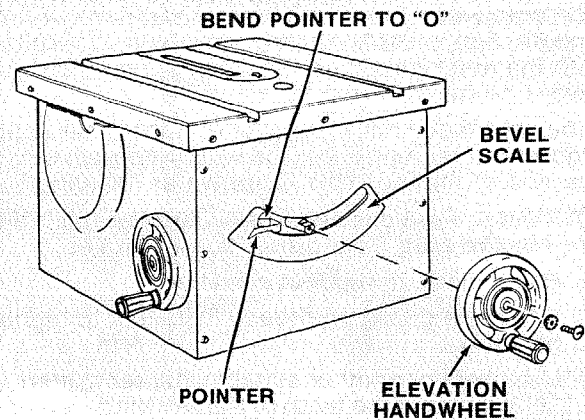

If blade is NOT SQUARE to table . . . the 90° LIMIT STOP must be ADJUSTED.

**CAUTION: Cover blade with piece of cardboard to protect your hand.**

1. Using a small size screwdriver, reach UNDERNEATH saw and loosen BOTH setscrews in 90° STOP COLLAR.  
NOTE: If you can't reach the setscrews, turn the TILT HANDWHEEL slightly.
2. ROTATE the STOP COLLAR moving it away from pivot nut.
3. TILT blade RIGHT or LEFT . . . checking with your square until blade is square to table.
4. ROTATE STOP COLLAR moving it toward PIVOT NUT until it TOUCHES the PIVOT NUT . . . TIGHTEN the setscrews.
5. Check POINTER, if it DOES NOT point to the "O" mark on the bevel scale, bend pointer to read "O".

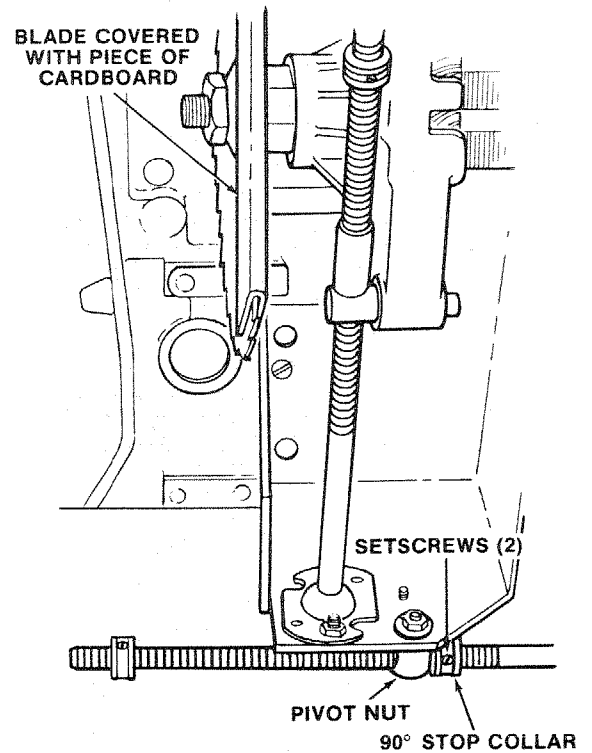

TILT blade to LEFT as far as it will go. It will stop when the PIVOT NUT is against the 45° STOP COLLAR.

Place an ACCURATE square against blade. Make sure square is not touching the TIP of one of the saw TEETH.

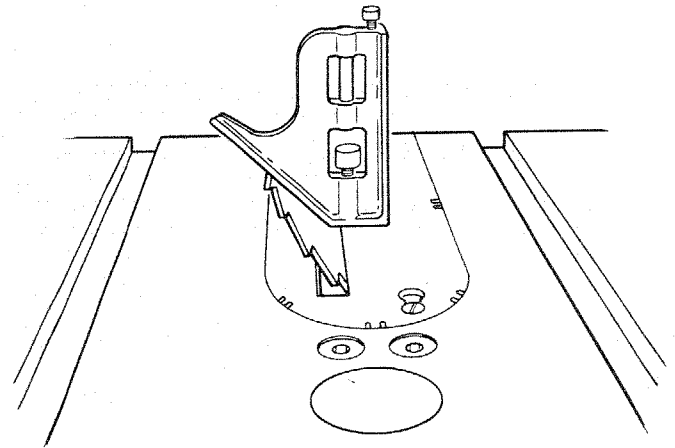

If blade is NOT 45° to table . . . the 45° STOP COLLAR must be ADJUSTED

1. Remove Elevation Handwheel.
2. Using a small size screwdriver, reach thru curved slot in front trip panel and loosen BOTH setscrews in 45° STOP COLLAR.  
NOTE: If you can't reach the setscrews, turn the TILT HANDWHEEL slightly.
3. ROTATE the STOP COLLAR moving it IN or OUT and TILT blade RIGHT or LEFT . . . checking with your square until blade is 45° to table.
4. TIGHTEN the setscrews.  
NOTE: If you can't reach the setscrews, turn TILT HANDWHEEL slightly.
5. Install Elevation Handwheel.

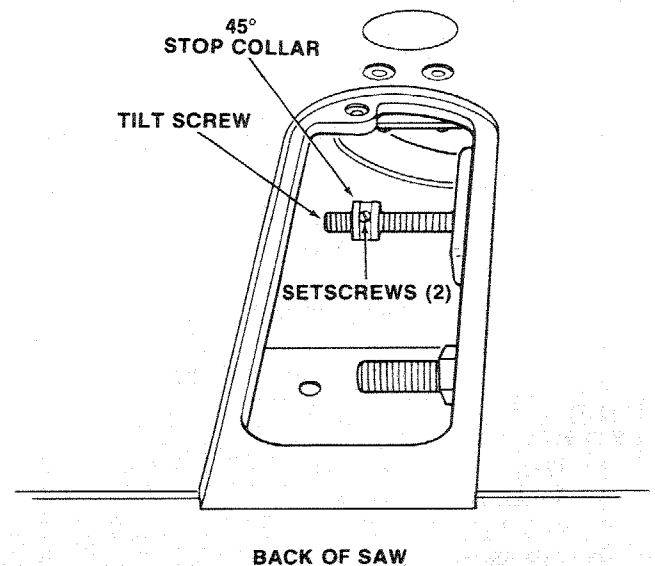

## BLADE ELEVATION

When the elevation handwheel is turned **CLOCKWISE**, until it stops, the blade must not be more than two and five eighths (2-5/8) inches above the table. If the blade extends more than 2-5/8 inches, the motor could interfere with the underside of the table causing misalignment.

With the blade extending two and five eighths (2-5/8) inches above the table, the **STOP COLLAR** and **SPACER** must be against the **ELEVATION SCREW PIVOT NUT**. If the blade extends more than 2-5/8 inches, loosen two screws in **STOP COLLAR**, and readjust it.

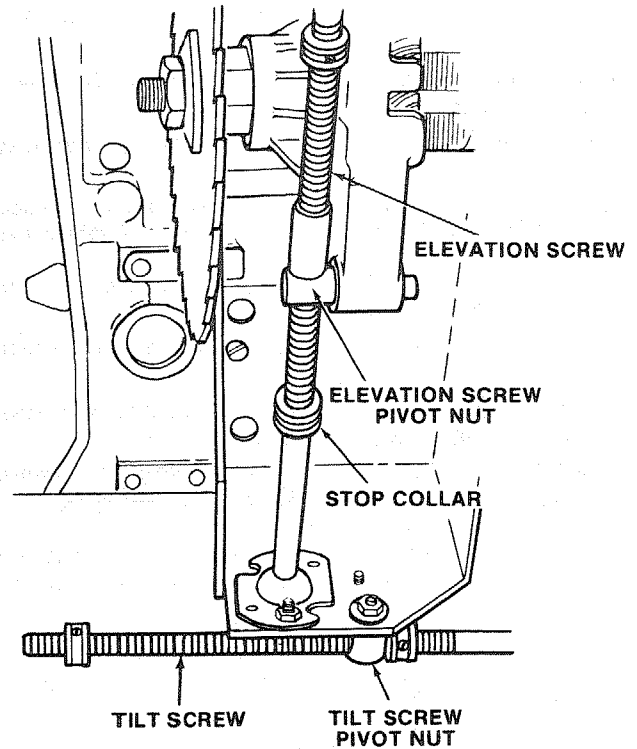

## TILT AND ELEVATION MECHANISM

The **HANDWHEELS** should turn freely without binding. The turning action can be adjusted by tightening or loosening the screws in the bearing retainer. Both handwheels must be removed to reach the adjusting screws.

**NOTE:** When adjusting the screws on the **TILT** bearing retainer, hold the nut inside using a 3/8 in. wrench. The screws for the **ELEVATION** bearing retainer can be reached with a small screwdriver through the curved slot on the front of the saw.

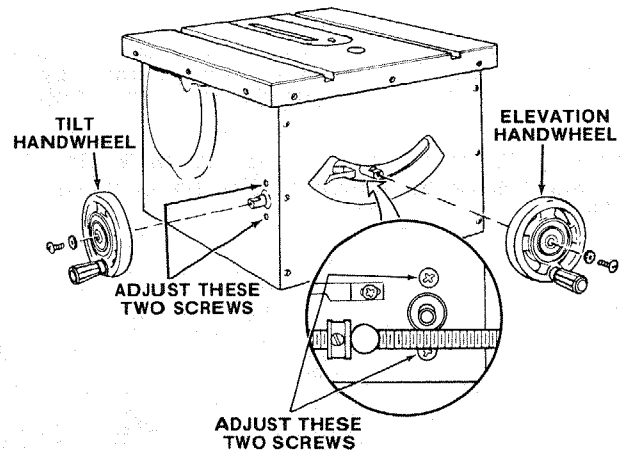

## ATTACHING AND ASSEMBLING TABLE EXTENSIONS

From among the loose parts find the following hardware: (Quantity indicated is for 2 extensions)

Ref. No.	Description	Qty.
1	Corner Support Bracket	4
2	Corner Stiffener Bracket	4
3	Truss Hd. Screw, 1/4-20 x 1	16
4	External Lockwasher, 1/4	16
5	Hex Nut, 1/4-20	16
6	Flat Washer (Dia. of Hole 17/64)	4

### HARDWARE FOR INSTALLING EXTENSIONS TO SAW TABLE

7	Hex Hd. Screw, 5/16-18 x 1-1/4	6
8	External Lockwasher, 5/16	6
9	Hex Nut, 5/16-18	6
10	Flat Washer (Dia. of Hole 11/32)	6

Assemble brackets with hardware as shown.

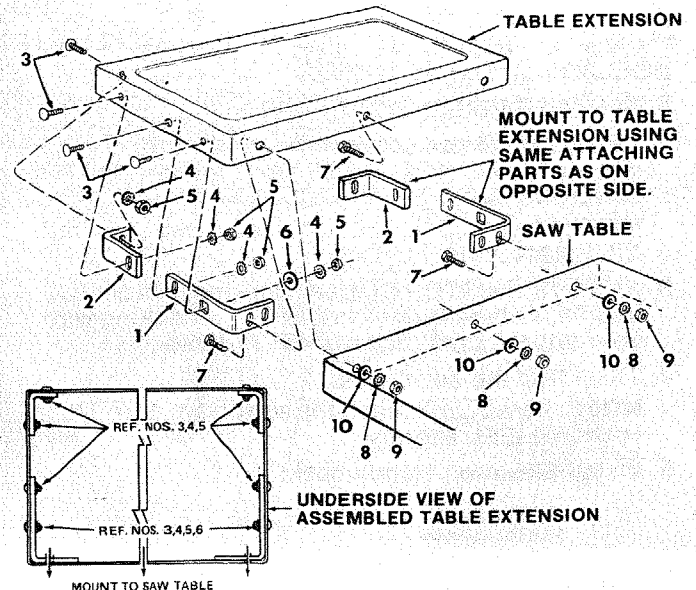

Insert three (3) 5/16-18 x 1-1/4 in. long screws through holes in each EXTENSION then through table. Install flat washer, lockwashers, and nuts on the screws . . . DO NOT TIGHTEN.

Align front edge of extension with front edge of saw table. Pull Extension UPWARDS above table surface . . . SLIGHTLY TIGHTEN SCREWS using 1/2 in. wrench.

Using small block of hardwood and hammer, tap extension DOWNWARDS at front, center and rear, until it is EVEN with table surface . . . TIGHTEN SCREWS.

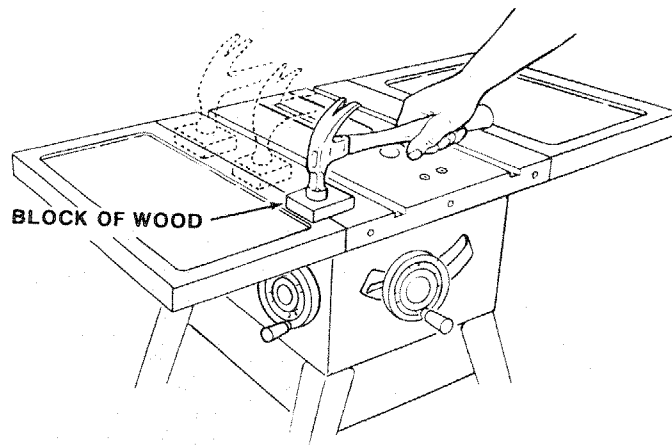

## ALIGNING EXTENSIONS

Lay REAR FENCE GUIDE BAR on table to act as a straightedge. If outer edge of extension is higher or lower than table surface:

1. Slightly loosen nut holding the corner support bracket to extension using 7/16 in. wrench.
2. Move end of extension up or down until outer edge is even with table surface . . . check with GUIDE BAR . . . tighten nuts.
3. Recheck INNER edge of extension to make sure it has not moved . . . readjust, if necessary.
4. Adjust right extension in same manner.

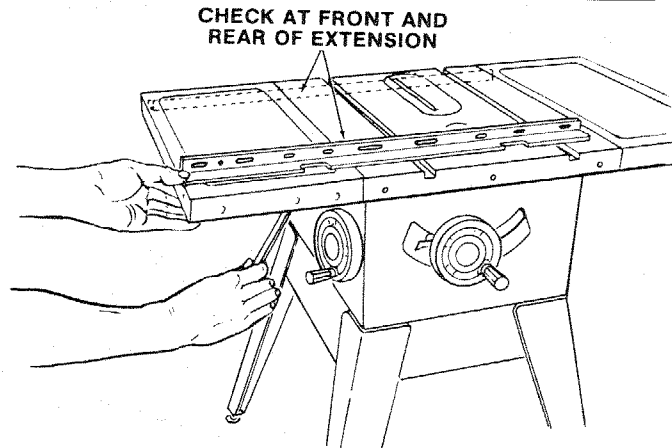

## INSTALLING RIP FENCE GUIDE BARS AND SWITCH

1. Locate the following loose parts:
 

Hex head screws, 5/16-18 x 3/4	2
External lockwashers, 5/16	2
Hex Nuts, 5/16-18	4
Hex head screws, 5/16-18 x 1-1/2	2
Hex head screws, 5/16-18 x 1	2
External Lockwashers, 5/16	4
Spacers, 3/4 x 1/2	2
Self threading nuts	2
Washers, 21/64	4
Switch Assembly	1
2. Insert a 1-1/2 inch long screw, external lockwasher, and flat washer through the sixth hole in the front fence bar.
3. Place 1/2 inch long spacer over screw threads and position screw through first hole on the right side of the cast iron table skirt.
4. Use fingers to thread screw into tapped hole until finger tight. Guide bar should be in a vertical position.

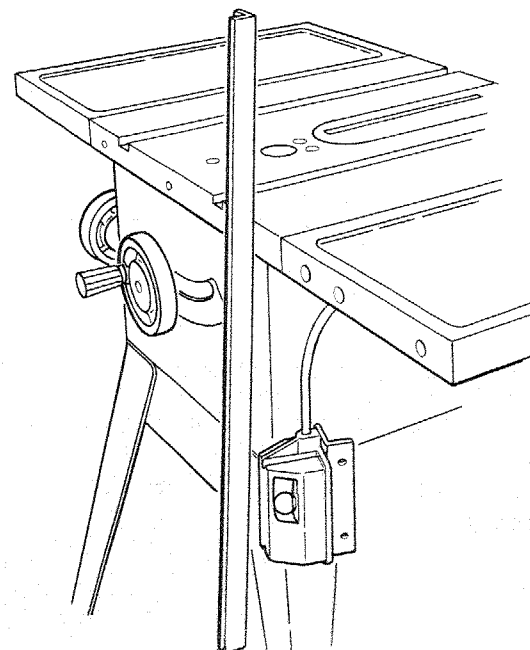
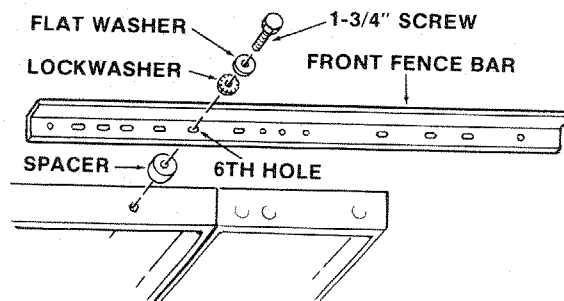

5. Mount switch to guide bar with 2 hex head screws, 5/16-18 x 3/4 lockwashers, and nuts. Securely tighten both nuts.
6. Insert 1-1/2 inch long screw through external lockwashers, flat washer and through the second hole in the guide bar. Place 1/2 inch long spacer over screw threads. Swing guide bar to horizontal position and screw the hex head screw into the center hole of the table skirt. Finger tighten both guide bar mounting screws.

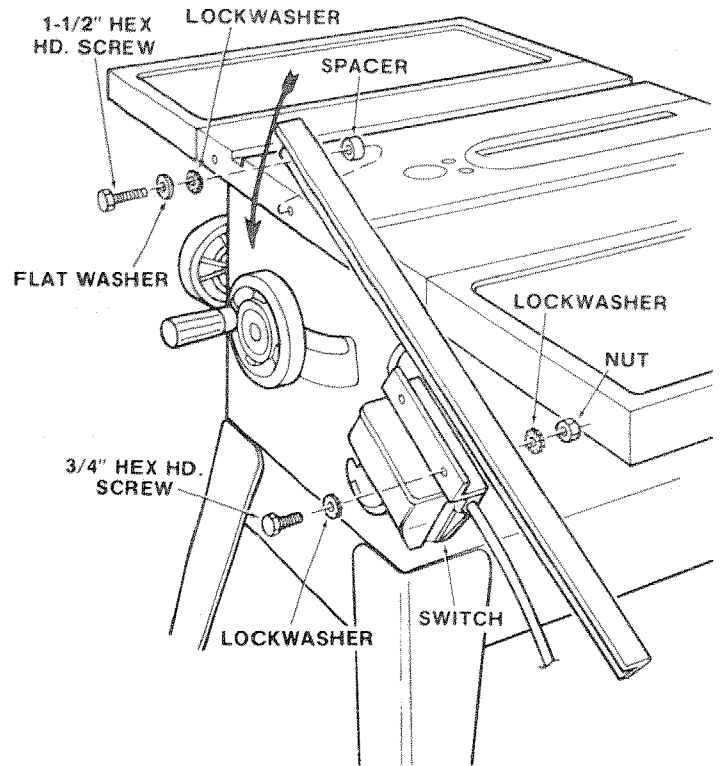

7. Insert one inch long screws in first and third holes of the rear guide bar and attach to table the same way as the front bar.
8. Insert ends of FENCE GUIDE BAR ROD through holes in bars as illustrated.

**NOTE:** The ends of the ROD are not threaded . . . the SELF THREADING NUTS will cut threads on the rod as they are screwed on. Just start nuts onto ends of rod.

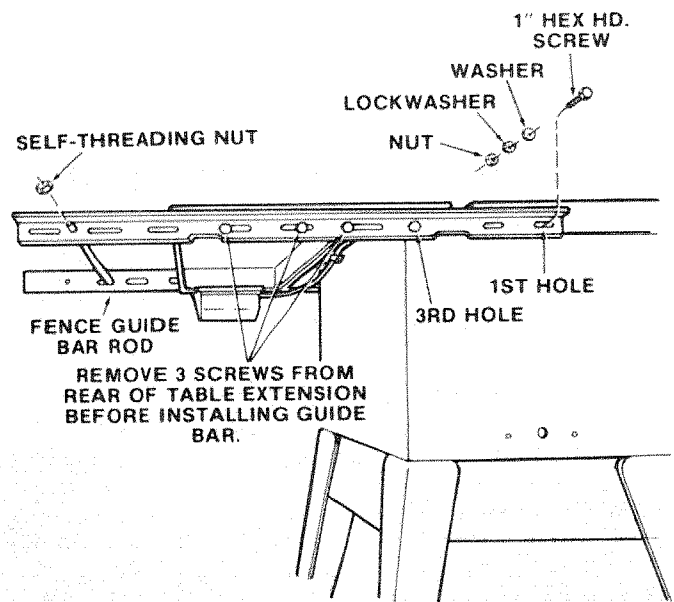

9. Hold rod with one hand and with a 1/2 in. wrench or pliers start screwing on ONE of the nuts only A TURN OR TWO . . . screw on other nut the same way.
10. Using TWO 1/2 in. wrenches or pliers tighten both of the nuts.

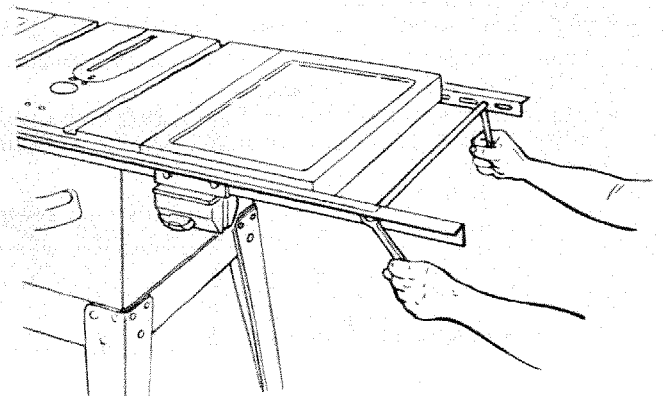

11. Slide the bars so that screws are in the MIDDLE of the slotted holes.
12. Position rip fence over miter gauge groove, holding up the rear end while engaging front end with bar . . . lower fence onto table.

**NOTE:** It may be necessary to loosen fence knob to allow fence to be installed on rip rail.

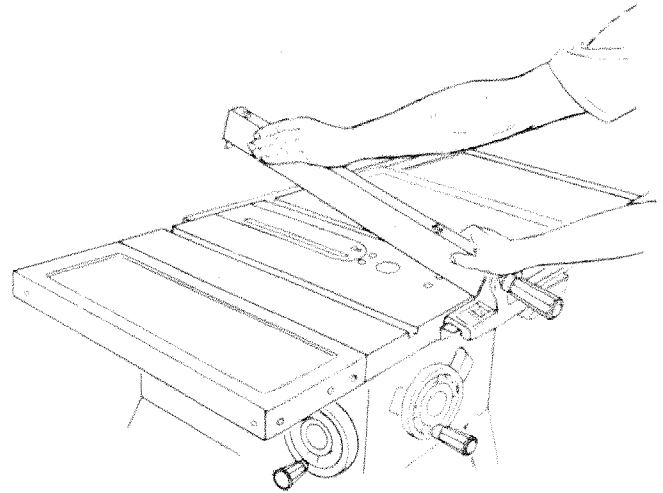

13. Move FRONT bar upwards until fence is approximately 1/32 in. above table . . . tighten screw at left end of bar.

**NOTE:** Fold a piece of newspaper making 8 thicknesses and place between rip fence and table to act as a spacer. This will hold the fence off of the table approx. 1/32 in.

14. Adjust rear bar so that the fence is approximately 1/32 in. above table . . . tighten screw at end of bar.
15. Replace screws in rear of table extension . . . be sure top surface of extension is PARALLEL to top surface of rear guide bar.

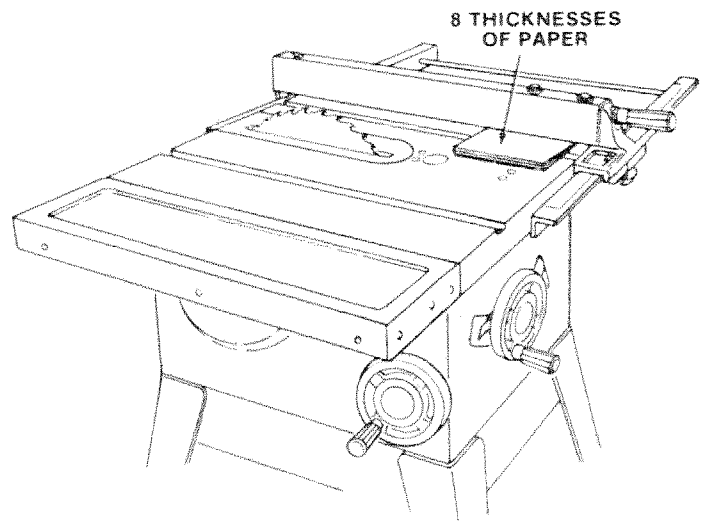

16. Move fence to RIGHT edge of table . . . make sure it is approximately 1/32 in. above table at front and rear and tighten screws.

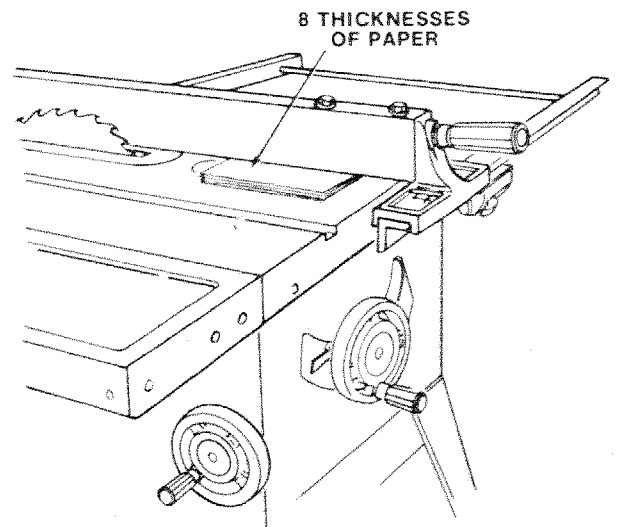

## ALIGNING RIP FENCE

The fence should slide easily along the bars and always remain in alignment (parallel to sawblade and miter gauge grooves).

The alignment is maintained by a spring underneath the rip fence which bears against the front guide bar.

To move the fence, loosen the lock handle and grasp the fence with one hand at the front.

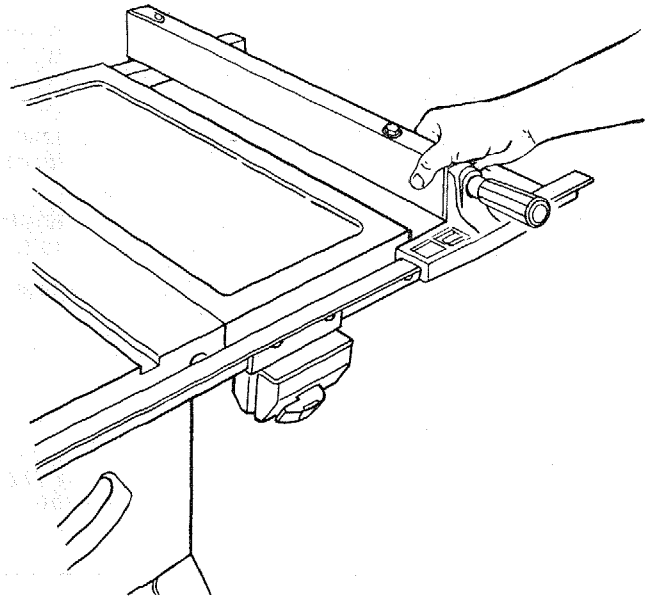

For very close adjustments, grasp the guide bar with both hands and move the fence with your thumbs.

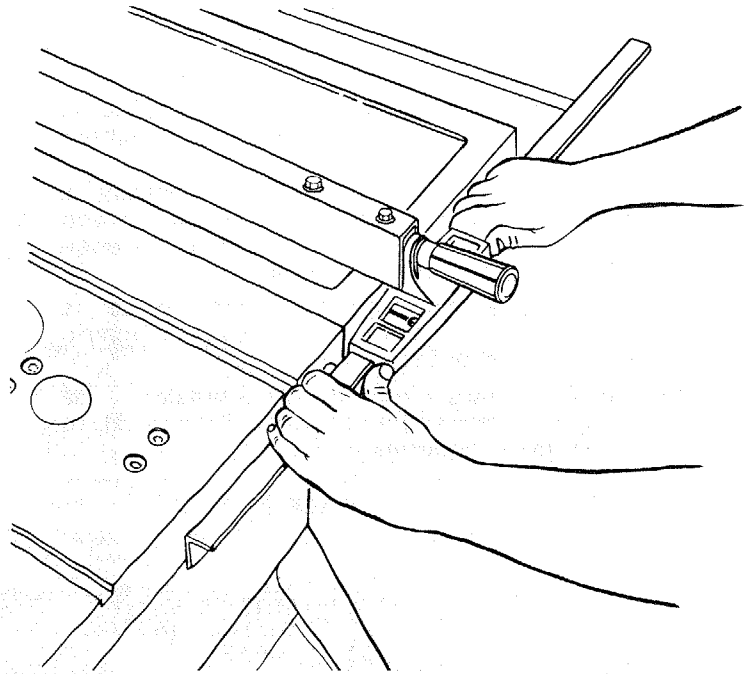

Place fence on saw but **DO NOT LOCK IT.**

Move the **REAR END** of the fence slightly to the right or left . . . when you release it, the fence should "spring" back to its original position.

If it does not, the spring pressure must be **INCREASED.**

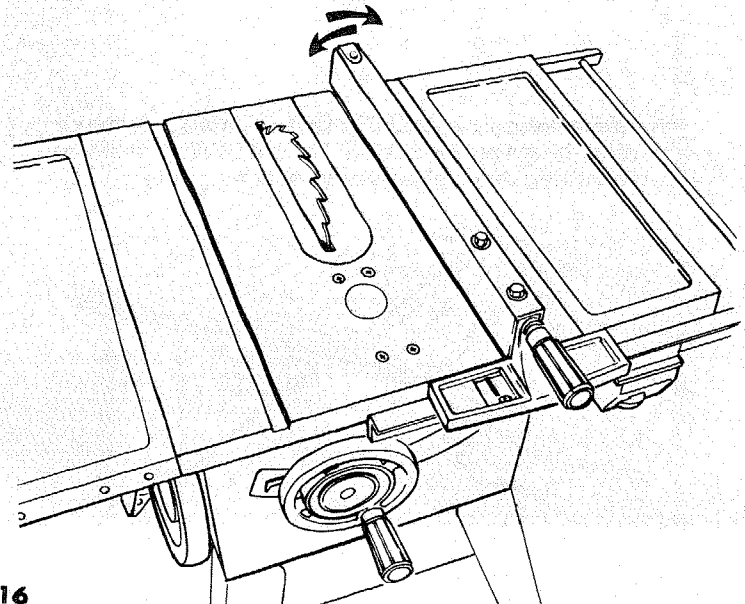

1. Loosen the screws.
2. Move Spring slightly toward front of fence.

**NOTE:** Applying a coat of paste wax to the rails will allow fence to be moved more easily.

If the fence does not slide easily along the bars, the pressure of the spring can be **REDUCED**.

1. Loosen the screws.
2. Move spring slightly toward rear of fence . . . tighten screws.

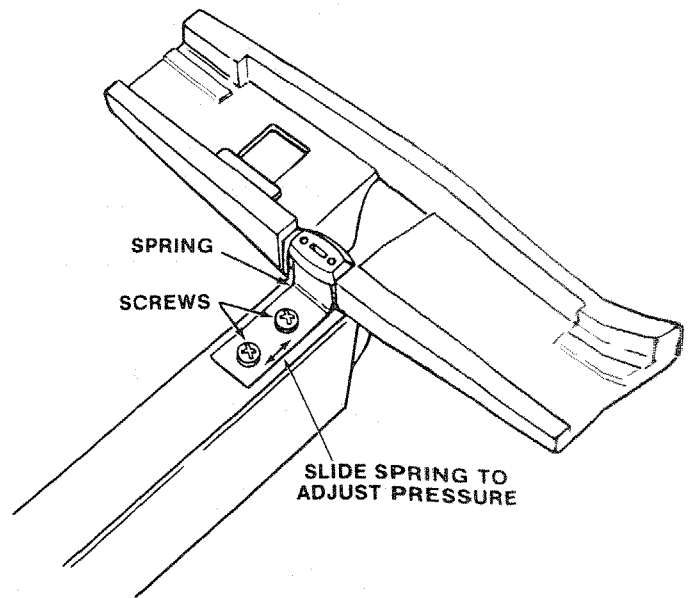

The rip fence must be **PARALLEL** with the sawblade and miter gauge grooves . . . Move fence until it is along side of groove. Do **NOT LOCK IT**. It should be parallel to groove. If it is not;

1. Loosen the two "Hex Head Screws."
2. Hold fence head tightly against bar . . . move end of fence so that it is parallel with groove.
3. Alternately tighten the screws.

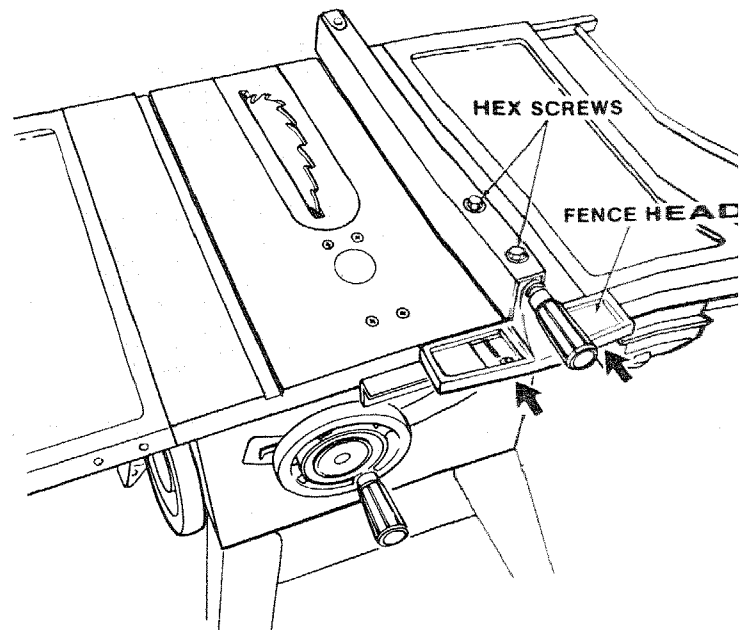

### ADJUSTING RIP SCALE INDICATOR

1. Turn **ELEVATION HANDWHEEL** clockwise until blade is up as high as it will go.  
**IMPORTANT: BLADE must be SQUARE (90°) to TABLE, in order to ALIGN rip fence.**
2. Using a rule, position fence on right side of sawblade 2 in. from the sides of the teeth . . . tighten lock handle.
3. Loosen screw holding the indicator . . . adjust so that it points to "2" on the rip scale . . . tighten screw.

**NOTE:** If you cannot adjust indicator so that it points to "2", loosen the screws holding the front guide bar and move the guide bar.

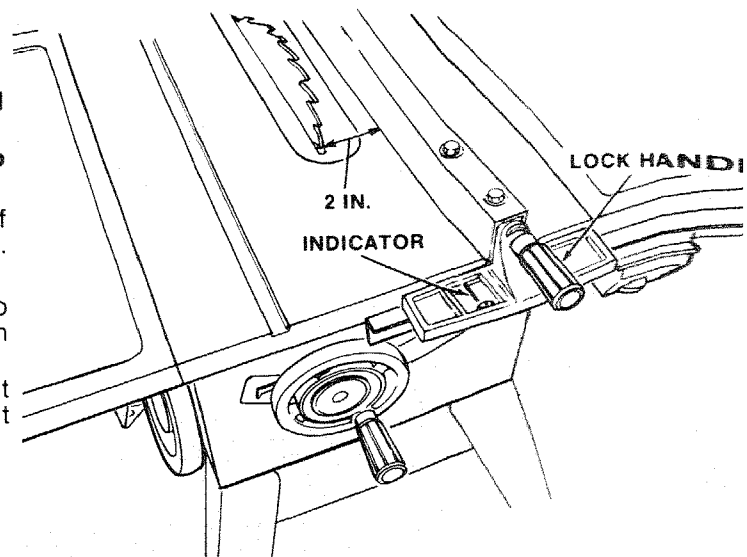

## INSTALLING BLADE GUARD

1. From among the loose parts, find the hardware as shown.

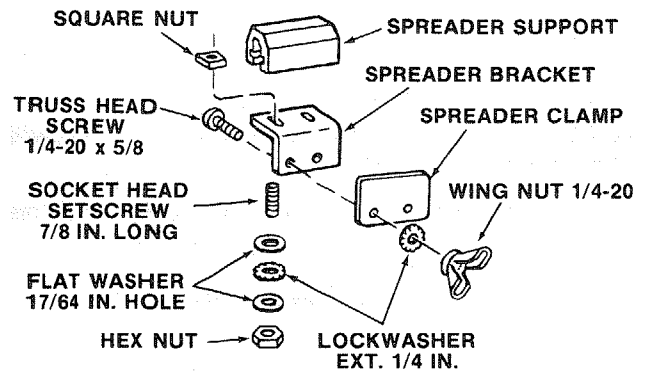

2. Position SPREADER SUPPORT on rod until it is even with the end of the rod.

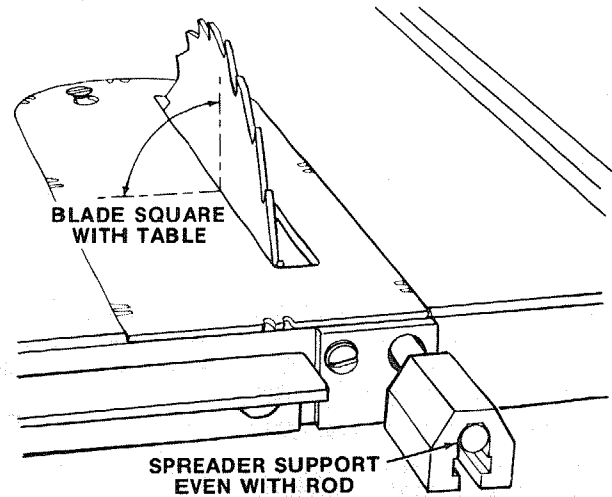

3. Assemble the 7/8 in. long setscrews, nuts, lockwashers and washers to the SPREADER SUPPORT BRACKET and slip the nuts into the slot in the spreader support.
4. Finger tighten ONLY THE HEX NUTS.

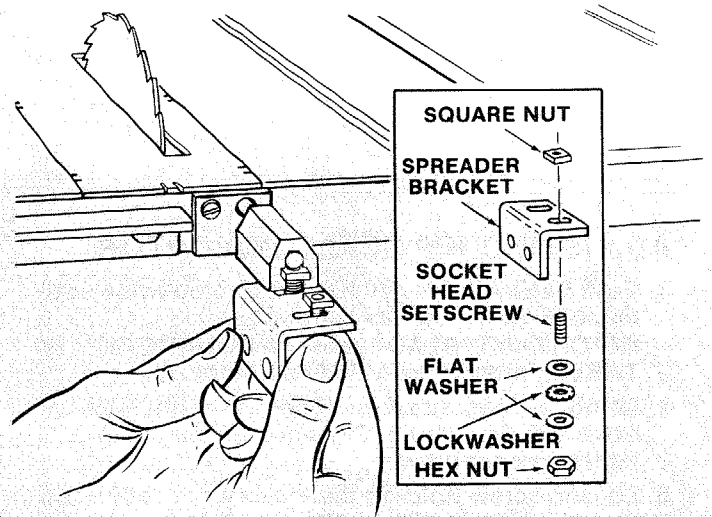

5. Lay a piece of flat straight wood and a square on saw table and rotate the SPREADER SUPPORT until the bracket is aligned with square.
6. MAKE SURE END OF SUPPORT, BRACKET AND ROD ARE EVEN . . . using an 1/8 in. setscrew wrench, TIGHTEN THE SET SCREWS ONLY.

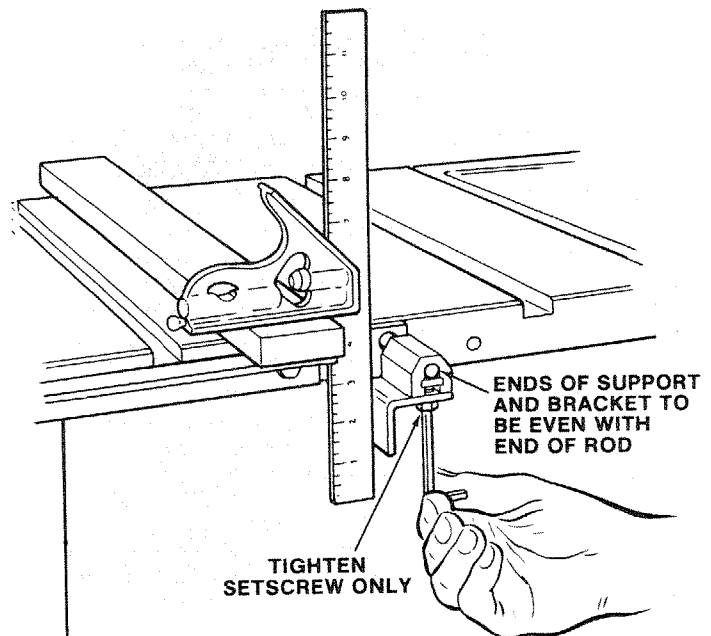

**IMPORTANT:** The Spreader must always be PARALLEL to the sawblade and in the MIDDLE of the cut (KERF) made by the sawblade.

**NOTE:** The spreader is thinner than the width of the KERF by approximately six thicknesses of paper.

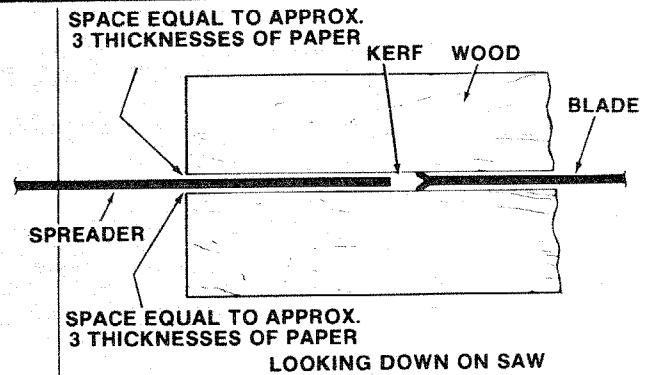

7. Make two folds in a small piece (6 x 6 in.) of ordinary NEWSPAPER making three thicknesses. The folded paper will be used as a "spacing gauge".

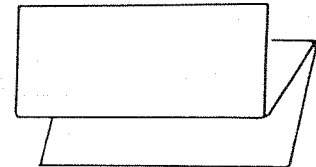

8. Raise blade to maximum height and make sure blade is square to the saw table.
9. Install the SPREADER CLAMP. Place spreader between spreader clamp and bracket. Move forward until all three are in line. TIGHTEN WINGSCREWS.
10. Lift up both ANTIKICKBACK PAWLS . . . insert one of the setscrew wrenches or a pencil in the notches to hold the pawls out of the way.
11. Lay a piece of straight flat wood against the sawblade. Insert folded paper between spreader and strip of wood.
12. MAKE SURE THE HEX NUTS UNDERNEATH ARE LOOSE.
13. Hold the spreader tightly against the wood and make sure the wood is against the saw blade. TIGHTEN THE HEX NUTS. This will align the spreader in the middle of the cut (KERF) made by sawblade.

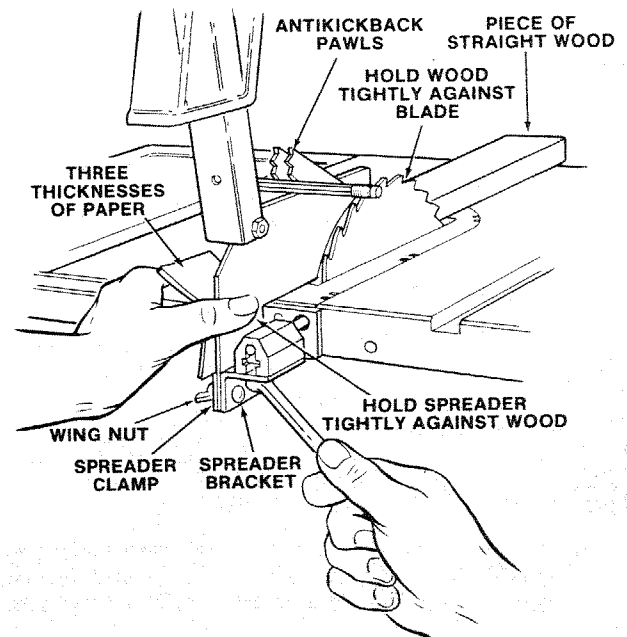

## ADJUSTING MITER GAUGE

**WARNING:** FOR YOUR OWN SAFETY, TURN SWITCH "OFF" AND REMOVE PLUG FROM POWER SOURCE OUTLET BEFORE MAKING ANY ADJUSTMENTS.

### MITER GAUGE

**NOTE:** The graduations on the miter gauge provide accuracy for average woodworking. In some cases where extreme accuracy is required, when making angle cuts, for example, make a trial cut and then recheck it with an accurate square or protractor.

If necessary, the miter gauge head can be swiveled slightly to compensate for any inaccuracy.

The HEAD should be SQUARE (90°) with the bar when the pointer points to "0".

To check for squareness, place an accurate square on the miter gauge. If the head is NOT SQUARE with the bar:

1. Loosen the lock knob.

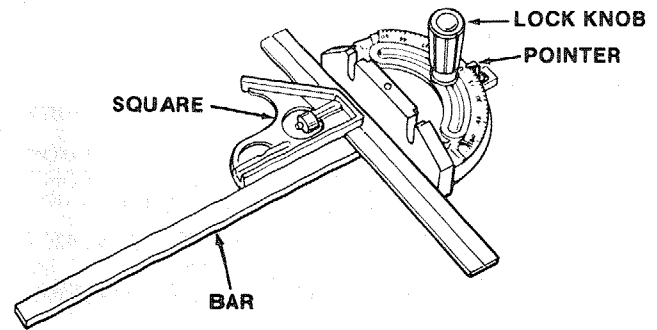

2. Position the head square with the bar . . . tighten the lock knob.

3. Loosen the screw and adjust the pointer, so it points to zero.

The swiveling movement of the head can be adjusted by tightening or loosening the set screw located in side of the head using the 1/8 in. setscrew wrench.

## GETTING TO KNOW YOUR SAW

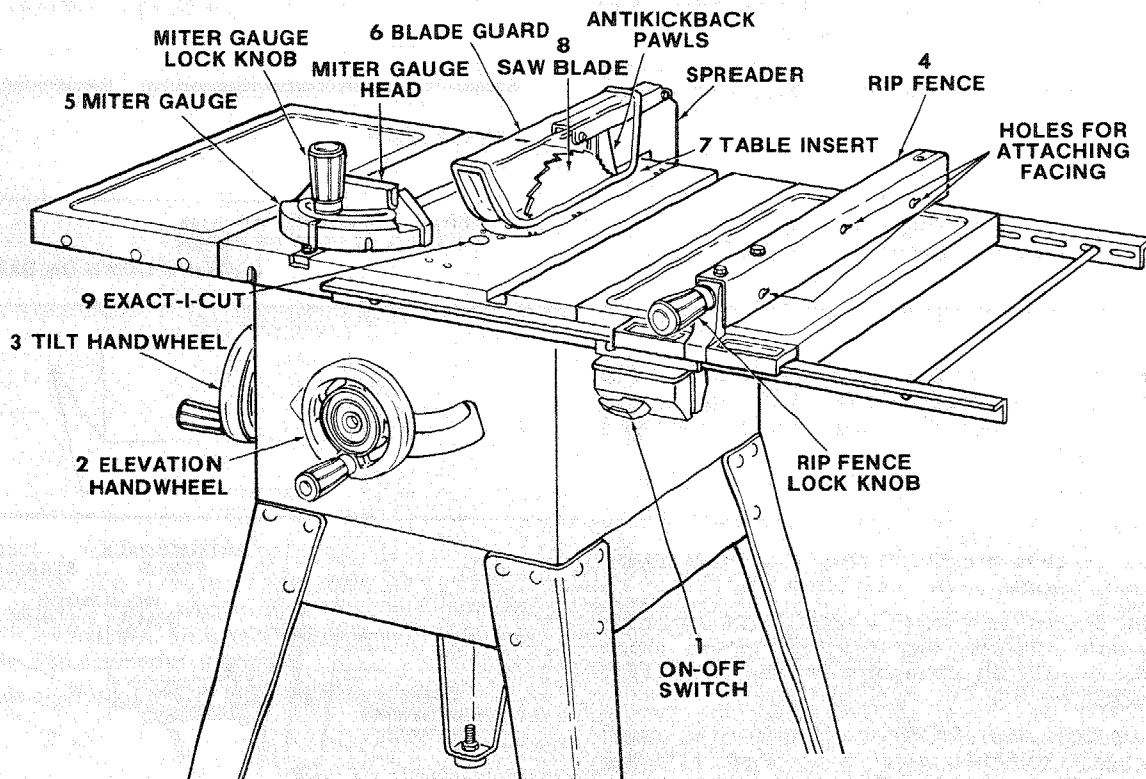

### 1 ON-OFF SWITCH

**CAUTION:** Before turning switch on, make sure the blade guard is correctly installed and operating properly.

The On-Off Switch has a locking feature. THIS FEATURE IS INTENDED TO PREVENT UNAUTHORIZED AND POSSIBLE HAZARDOUS USE BY CHILDREN AND OTHERS.

A. TO turn saw ON . . . stand to either side of the blade never in line with it . . . insert finger under switch lever and pull END of lever out.

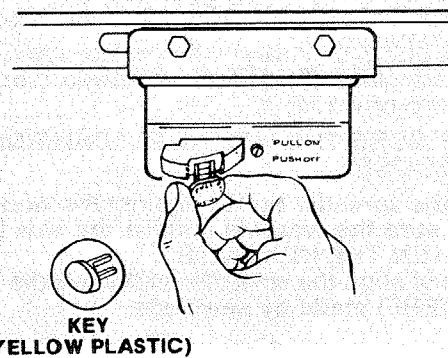

Do not cycle the motor switch on and off rapidly, as this may cause the sawblade to loosen. In the event this should ever occur, allow the sawblade to come to a complete stop and retighten the arbor nut normally, not excessively. Never leave the saw while the power is "ON".

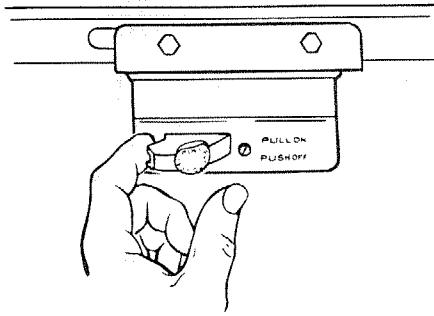

- B. TO turn saw OFF . . . PUSH lever in. Never leave the saw until the cutting tool has come to a complete stop.
- C. TO lock switch in OFF position . . . hold switch IN with one hand . . . REMOVE key with other hand.

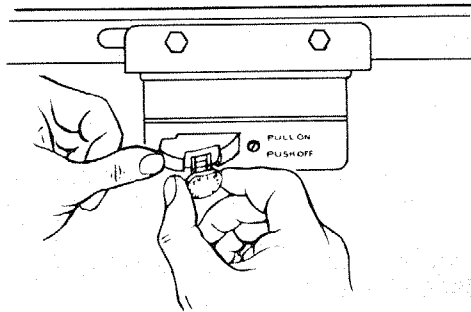

**WARNING: FOR YOUR OWN SAFETY, LOWER BLADE OR OTHER CUTTING TOOL BELOW TABLE SURFACE. (IF BLADE IS TILTED, RETURN IT TO VERTICAL (90°) POSITION). ALWAYS LOCK THE SWITCH "OFF". WHEN SAW IS NOT IN USE . . . REMOVE KEY AND KEEP IT IN A SAFE PLACE . . . ALSO . . . IN THE EVENT OF A POWER FAILURE (ALL OF YOUR LIGHTS GO OUT) TURN SWITCH OFF . . . LOCK IT AND REMOVE THE KEY. THIS WILL PREVENT THE SAW FROM STARTING UP AGAIN WHEN THE POWER COMES BACK ON.**

- 2 **ELEVATION HANDWHEEL . . .** elevates or lowers the blade. Turn clockwise to elevate . . . counterclockwise to lower.
- 3 **TILT HANDWHEEL . . .** tilts the blade for bevel cutting. Turn clockwise to tilt toward left . . . counterclockwise to tilt toward vertical.

When the blade is tilted to the LEFT as far as it will go, it should be at 45° to the table and the bevel indicator should point 45°.

**NOTE:** There are LIMIT STOPS on the saw which prevent the blade from tilting beyond 45° to the LEFT and 90° to the RIGHT. (See "Adjustments" section "Blade Tilt, or Squareness of Blade to Table").

- 4 **RIP FENCE . . .** is locked in place by tightening the lock knob. To move the fence, loosen the knob and grasp the fence with one hand at the front.

Holes are provided in the rip fence for attaching a wood facing when using the dado head, or molding head.

Select a piece of smooth straight wood approx. 3/4" thick, at least as long as the rip fence, and at least 7-1/2" wide (high) to permit clamping of featherboards.

Attach it to the fence with three Round Head #10 Wood Screws 2 in. long. To remove the facing, loosen the screws, slide the facing forward and pull the screws through the round holes.

If you are making a rip type cut in material thinner than 3/16 in. while the fence is positioned over the depressed area of table extension, the facing should be attached to the fence so that the bottom edge touches the top surface of the extension. In this case, the facing must be shorter than the fence. This will prevent thin material from sliding under the rip fence.

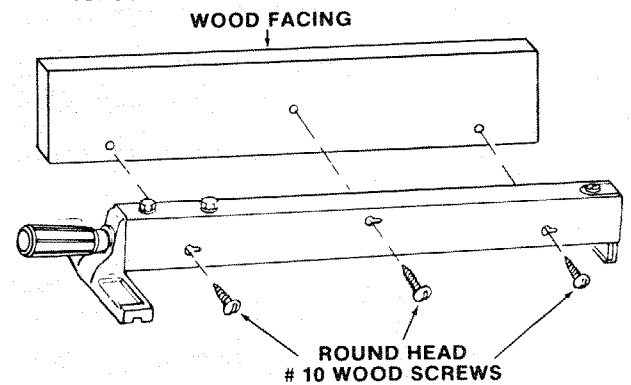

- 5 **MITER GAUGE . . .** head is locked in position for crosscutting or mitering by tightening the lock knob. ALWAYS LOCK IT SECURELY WHEN IN USE.

Slots are provided in the miter gauge for attaching an AUXILIARY FACING to make it easier to cut long pieces. Be positive facing does not interfere with the proper operation of the sawblade guard.

Select a suitable piece of smooth straight wood . . . drill two holes and attach it with screws.

**NOTE:** When bevel crosscutting, attach facing so that it extends to the right of the miter gauge and use the miter gauge in the groove to the right of the blade.

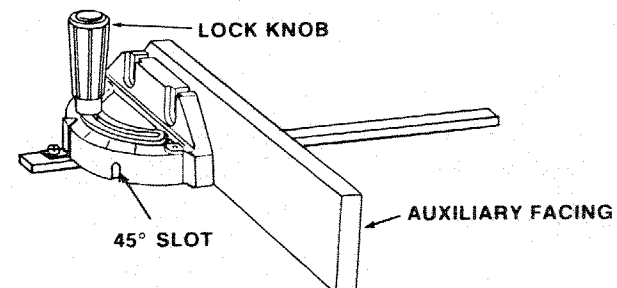

**6 BLADEGUARD** must always be in place and working properly for all thru-sawing cuts. That is, all cuts whereby the blade cuts completely through the workpiece.

To remove the guard for special operations, loosen the wing nuts and slide the guard off of the rod. **DO NOT DISTURB THE SETTING OF THE ROD.**

When replacing the guard, make sure the PIN in the rod engages with the NOTCH in the spreader support. Make sure wing screws are tightened securely.

**7 TABLE INSERT** is removable for removing or installing blades or other cutting tools.

**WARNING: TO AVOID INJURY DUE TO ACCIDENTAL START, TURN SWITCH "OFF" AND REMOVE PLUG FROM POWER SOURCE OUTLET BEFORE REMOVING INSERT.**

- A. Lower the blade below the table surface.
- B. Raise blade guard.
- C. Loosen Screw.
- D. Lift insert from front end, and pull toward front of saw.

NEVER OPERATE THE SAW WITHOUT THE PROPER INSERT IN PLACE. USE THE SAW BLADE INSERT WHEN SAWING . . . USE THE COMBINATION DADO MOLDING INSERT WHEN DADOING OR MOLDING.

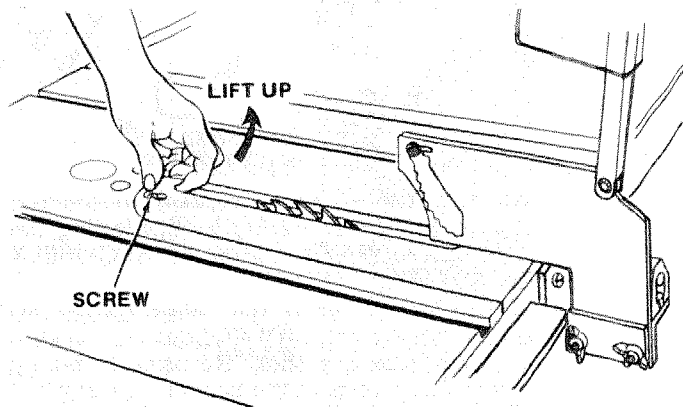

## 8 REMOVING AND INSTALLING SAWBLADE

**WARNING: TO AVOID INJURY DUE TO ACCIDENTAL START, TURN SWITCH "OFF" AND REMOVE PLUG FROM POWER SOURCE OUTLET BEFORE REMOVING OR INSTALLING SAWBLADE.**

- A. Remove insert.
- B. Place ARBOR wrench on flat surfaces of saw ARBOR . . . ARBOR NUT wrench on nut . . . position wrenches as shown . . . hold your hands well above blade.
- C. With ARBOR wrench against table, PULL ARBOR NUT wrench FORWARD to LOOSEN nut.

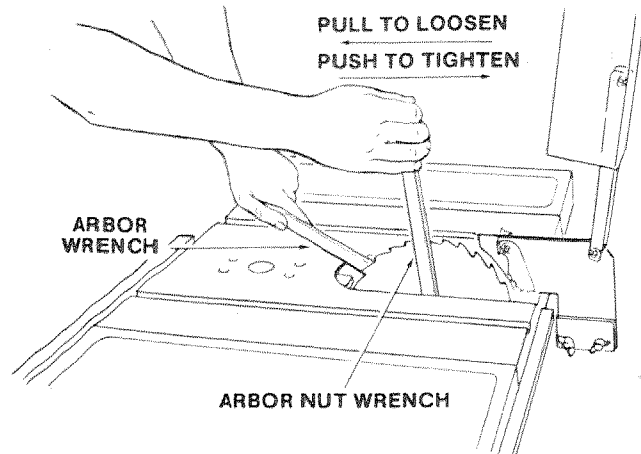

D. To TIGHTEN nut . . . HOLD ARBOR wrench against rear of table . . . PUSH ARBOR NUT wrench toward rear.

**NOTE:** When installing the blade . . . make sure the teeth are pointing toward the front of the saw . . . and that the blade and collars are clean, and free from any burrs.

The HOLLOW side of the collars must be against the blade.

Always tighten the arbor nut securely.

E. To replace insert.  
Place insert into insert opening in table and push toward rear of saw until keyslot in insert will drop over screw. Tighten screw.

Do not tighten screw to the point where it will deflect the insert.

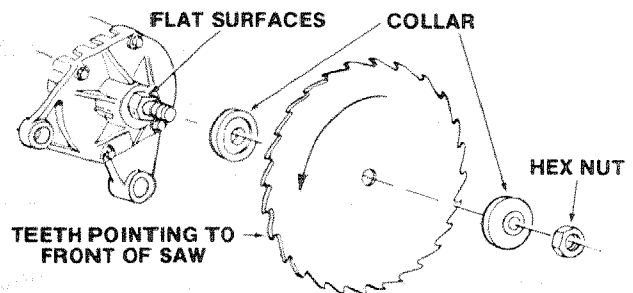

## 9 EXACT-I-CUT

The "yellow" plastic disc imbedded in the table in front of the sawblade, is provided for marking the location of the "sawcut" on the workpiece.

- A. Check disc . . . if it is above table surface, place a piece of hardwood on top of it and tap it down.
- B. With blade 90° (square to table) cut off a piece of wood.
- C. Pull miter gauge back until wood is over disc. Using very sharp pencil, mark a line on disc.

- D. With miter gauge in right hand groove, follow same procedure and mark another line on disc.
- E. These lines indicate the "path" of the cut (kerf) made by the sawblade.

SHOWN WITH HOLD-DOWN CLAMP  
(OPTIONAL ACCESSORY)

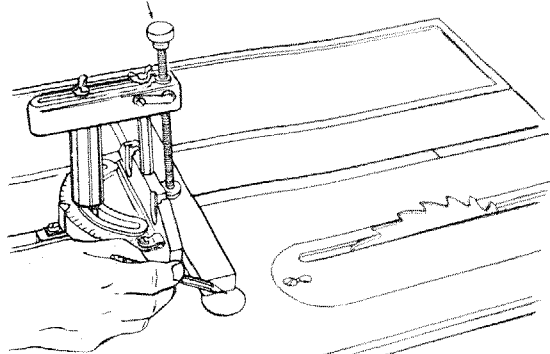

BLADE GUARD NOT SHOWN FOR PICTURE CLARITY

- F. When cutting the workpiece, line up mark on workpiece with line on disc.
- Use the hold-down clamp (optional accessory) on the miter gauge for greater accuracy.

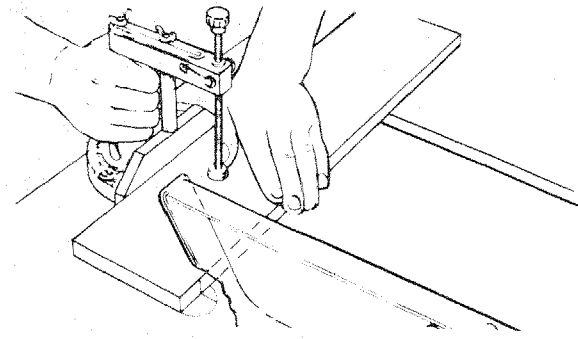

## BASIC SAW OPERATION

### WORK HELPERS

Before cutting any wood on your saw, study all of the "Basic Saw Operations".

Notice that in order to make some of the cuts, it is necessary to use certain devices "Work Helpers" like the Push Stick, the Push Block and the Auxiliary Fence/Work Support, which you can make yourself. After you have made a few practice cuts, make up these "helpers" before starting any projects. Make the "Push Stick" first.

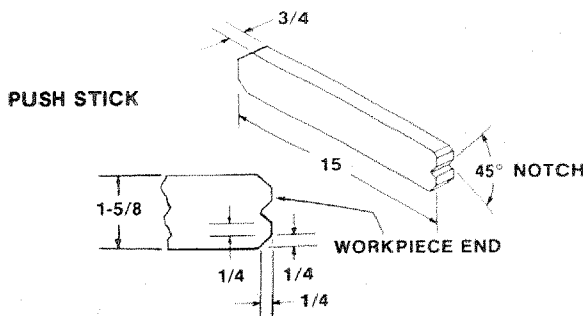

### PUSH STICK AND PUSH BLOCK

Make the Push Stick using a piece of 1 x 2, or rip one from a wide board, say 11-1/2 in. wide, and set the rip fence 9-7/8 in. from the sawblade.

Make the Push Block using a piece of 3/8 in. and 3/4 in. plywood.

The small piece of wood 3/8 in. x 3/8 in. x 2-1/2 in. should be GLUED to the plywood ... DO NOT USE NAILS. This is to prevent dulling the sawblade in the event you mistakingly cut into the push block.

Position the handle in the center of the plywood and fasten together with glue and woodscrews.

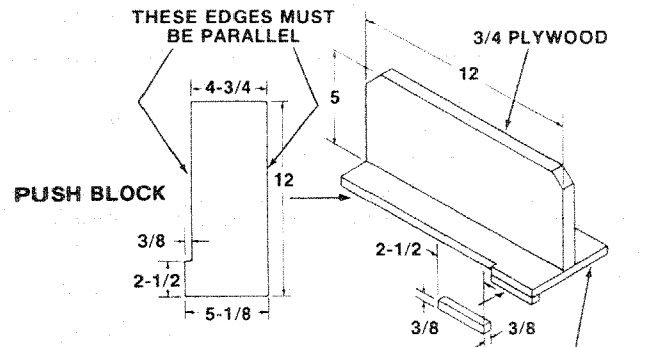

### AUXILIARY FENCE/WORK SUPPORT

Make one using a piece of 3/8 in. and 3/4 in. plywood. Fasten together with glue and woodscrews.

NOTE: Since the Push Block is used with the Auxiliary Fence, the 4-3/4 in. dimensions must be held identical on both the pieces.

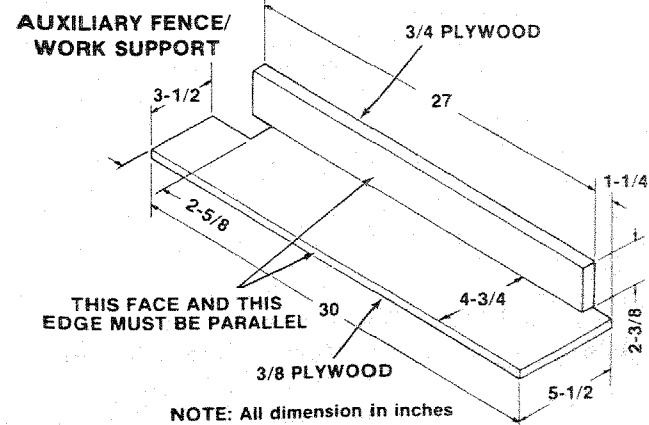

## USING THE MITER GAUGE

THE MITER GAUGE IS USED WHEN **CROSSCUTTING, MITER CUTTING, BEVEL CUTTING, COMPOUND MITER CUTTING, DADOING** and when **RABBETTING AND MOLDING** across the end of a narrow workpiece.

**WARNING: FOR YOUR OWN SAFETY, ALWAYS OBSERVE THE FOLLOWING SAFETY PRECAUTIONS IN ADDITION TO THE SAFETY INSTRUCTIONS ON PAGES 2, 3, and 4.**

1. Never make these cuts freehand (without using the miter gauge or other auxiliary devices) because the blade could bind in the cut and cause a **KICKBACK** or cause your fingers or hand to slip into the blade.
2. Always lock the miter gauge securely when in use.
3. Remove rip fence from table.
4. Make sure blade guard is installed for all "thru-sawing" operations (when sawblade cuts entirely thru the thickness of the workpiece.) Replace guard **IMMEDIATELY** after completion of dadoing, molding or rabbeting cuts.
5. Have blade extend approximately 1/8 in. above top of workpiece. Additional blade exposure would increase the hazard potential.
6. Do not stand directly in front of the blade in case of a **THROWBACK** (Small cut-off piece caught by the back of the blade and thrown toward the operator). Stand to either side of the blade.
7. Keep your hands clear of the blade and out of the path of the blade.
8. If blade stalls or stops while cutting, **TURN SWITCH OFF** before attempting to free the blade.
9. Do not reach over or behind the blade to pull the workpiece through the cut . . . to support long or heavy workpieces . . . to remove cut-off pieces of material or **FOR ANY OTHER REASON**.
10. Do not pick up small pieces of cut-off material from the table. **REMOVE** them by pushing them **OFF** the table with a long stick. Otherwise they could be thrown back at you by the rear of the blade.
11. Do not remove small pieces of cut-off material that may become **TRAPPED** inside the blade guard while the saw is **RUNNING**. **THIS COULD ENDANGER YOUR HANDS** or cause a **KICKBACK**.  
Turn the saw **OFF**. After the blade has stopped turning, lift the guard and remove the piece.

## CROSSCUTTING

**CROSSCUTTING** is known as cutting wood across the grain, at 90°, or square with both the edge and the flat side of the wood. This is done with miter gauge set at "0".

The graduations on the miter gauge provide accuracy for average woodworking. In some cases where extreme accuracy is required, when making angle cuts, for example, make a trial cut and then recheck it with an accurate square, or protractor.

If necessary, the miter gauge head can be swiveled slightly to compensate for any inaccuracy.

**NOTE:** The space between the miter gauge bar and the groove in the table is held to a minimum during manufacturing.

For maximum accuracy when using the miter gauge, always "favor" one side of the groove in the table. In other words, don't move the miter gauge from side to side while cutting, but keep one side of the bar riding against one side of the groove.

**NOTE:** Glue a piece of sandpaper to the face of the miter gauge head. This will help prevent the workpiece from "creeping" while it is being cut.

The Hold-Down Clamp (Optional Accessory) should be used on the miter gauge for greater accuracy.

The miter gauge may be used in either of the grooves in the table. Make sure it is locked. When using the miter gauge in the **LEFT** hand

- groove, hold the workpiece firmly against the miter gauge head with your left hand, and grip the lock handle with your right.
- When using the **RIGHT** Hand groove, hold the workpiece with your right hand and the lockhandle with your left hand.

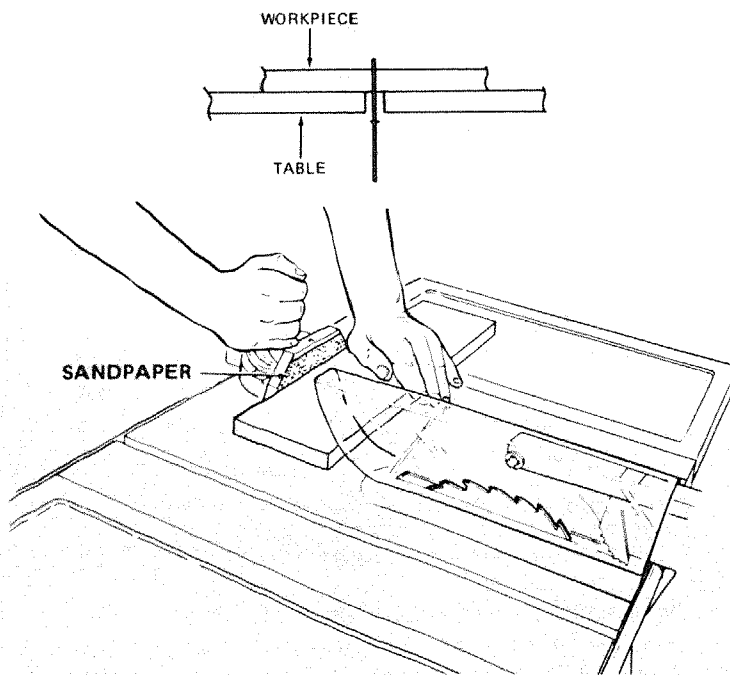

groove, hold the workpiece firmly against the miter gauge head with your left hand, and grip the lock handle with your right.

When using the **RIGHT** Hand groove, hold the workpiece with your right hand and the lockhandle with your left hand.

When cutting long workpieces, invert AUXILIARY FENCE/WORK SUPPORT and position it on top of the guide bars to support the workpieces as near to the end as possible. If this does not adequately support the workpiece, you can make a simple support by clamping a piece of plywood to a sawhorse.

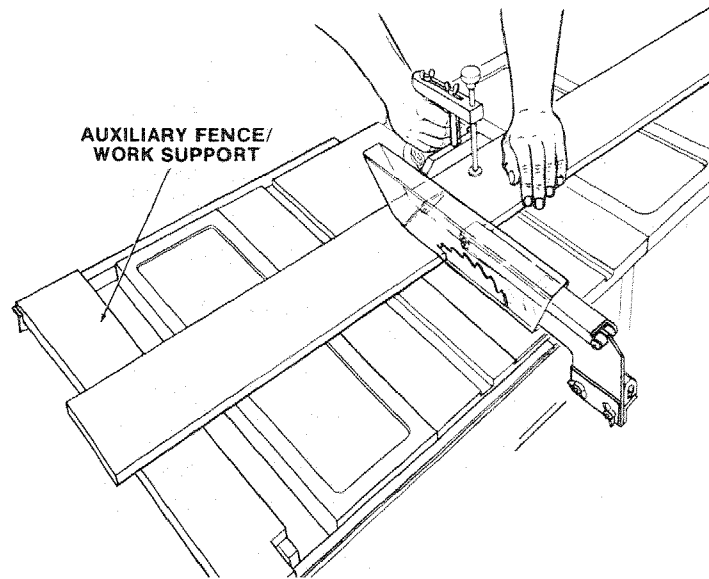

## REPETITIVE CUTTING

REPETITIVE CUTTING is known as cutting a quantity of pieces the same length without having to mark each piece.

1. Use the Stop Rods (optional accessory) only for cutting duplicate pieces 6 in. long and longer.
2. DO NOT FEED workpiece with RIGHT Hand, merely guide it, making sure that it does not bind or pinch the sawblade.

When making repetitive cuts from a long workpiece, make sure it is adequately supported.

Use the Hold-Down Clamp (Optional Accessory) on the miter gauge for greater accuracy.

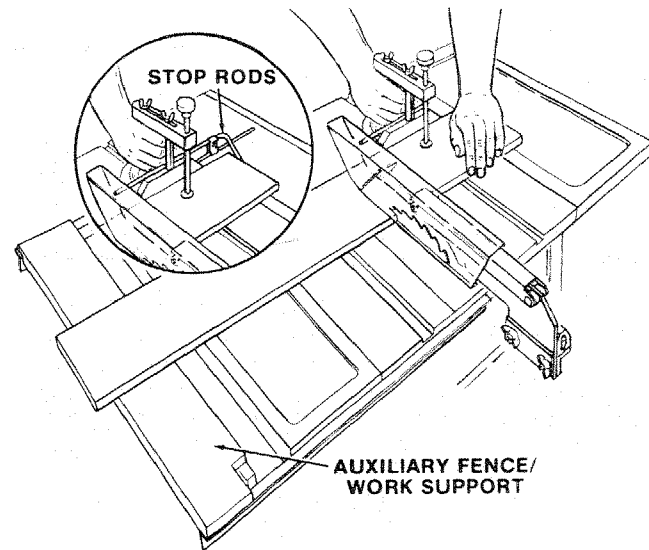

1. NEVER USE THE RIP FENCE AS A LENGTH STOP BECAUSE THE CUTOFF PIECE COULD BIND BETWEEN THE FENCE AND THE BLADE CAUSING A KICKBACK.

2. When making repetitive cuts shorter than 6 in., clamp a block of wood 2 in. long to the table to act as a length stop. Do not clamp directly to the bottom edge of the table because the "swivel" of the clamp will not grip properly. Place a small block of wood between the bottom edge of the table and the "C" clamp.

**CAUTION: When clamping the block, make sure that the end of the block is well in front of the sawblade. Be sure it is clamped securely.**

3. Slide the workpiece along the miter gauge until it touches the block . . . hold it securely or clamp it with the Hold-Down Clamp (Optional Accessory).
4. Make the cut . . . pull the workpiece back . . . push the cut off piece off the table with a long push stick . . . DO NOT ATTEMPT TO PICK IT UP AS THIS COULD ENDANGER YOUR HANDS.

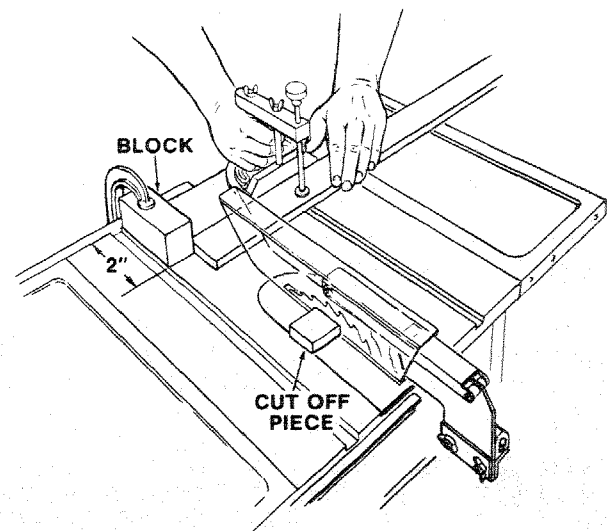

## MITER CUTTING

MITER CUTTING is known as cutting wood at an angle other than 90° with the edge of the wood. Follow the same procedure as you would for crosscutting.

Adjust the miter gauge to the desired angle, and lock it.

The miter gauge may be used in either of the grooves in the table.

When using the miter gauge in the LEFT Hand groove, hold the workpiece firmly against the miter gauge head with your left hand, and grip the lock knob with your right.

When using the RIGHT hand groove, hold the workpiece with your right hand and the knob with your left hand.

Use the Hold-Down Clamp (Optional Accessory) on the miter gauge for greater accuracy.

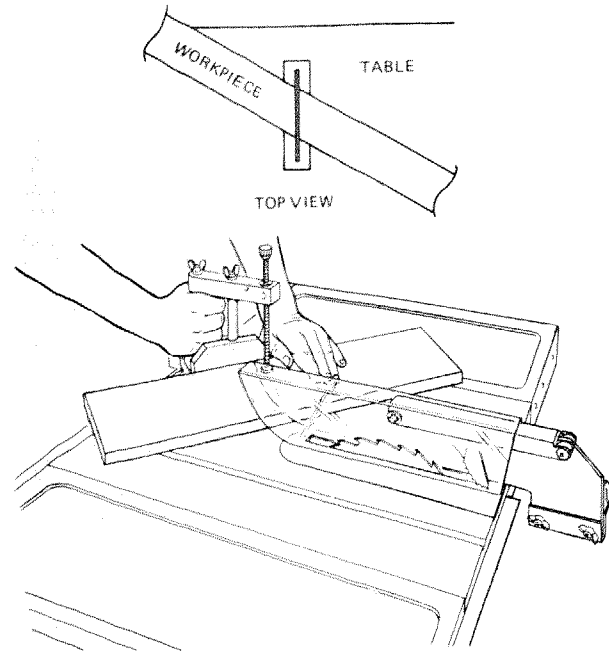

## BEVEL CROSSCUTTING

BEVEL CROSSCUTTING is the same as crosscutting except that the wood is also cut at an angle . . . other than 90° with the flat side of the wood.

**Lower blade to about 2 inches above the table top before tilting blade. Failure to do this may result in damage to your saw.**

Adjust the blade to the desired angle.

Use the Miter Gauge in the groove to the RIGHT of the blade. It cannot be used in the groove to the LEFT because the blade guard will interfere. Hold the workpiece with your right hand and the lockhandle with your left hand.

Use the AUXILIARY FENCE/WORK SUPPORT for additional support of the workpiece.

Lay it across the guide bars to support the workpiece as near to the end as possible.

Use the Hold-Down Clamp (Optional Accessory) on the miter gauge for greater accuracy.

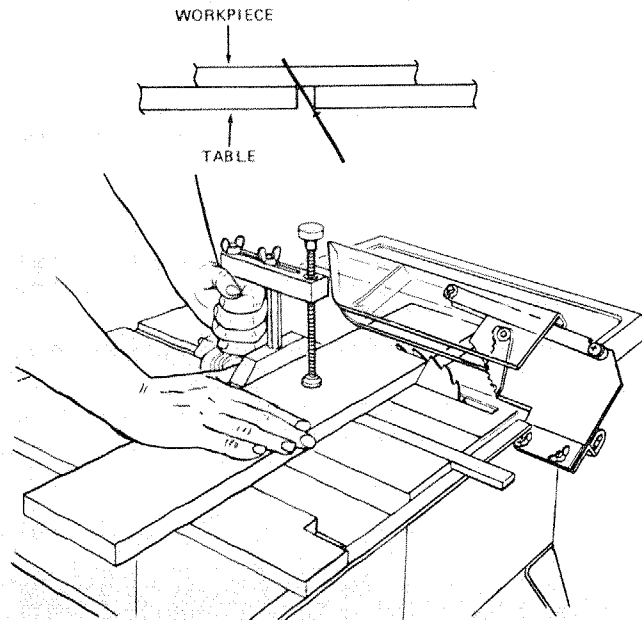

## COMPOUND MITER CUTTING

COMPOUND MITER CUTTING is a combination of miter cutting and bevel crosscutting. The cut is

made at an angle other than 90° to both the edge and the flat side of the wood.

Adjust the miter gauge and the blade to the desired angle . . . Make sure miter gauge is locked.

## USING THE RIP FENCE

**RIPPING, BEVEL RIPPING, PLOUGHING, MOLDING, RESAWING AND RABBETING** are performed using the RIP FENCE together with the AUXILIARY FENCE/WORK SUPPORT, PUSH STICK OR PUSH BLOCK.

**WARNING: FOR YOUR OWN SAFETY, ALWAYS OBSERVE THE FOLLOWING SAFETY PRECAUTIONS IN ADDITION TO THE SAFETY INSTRUCTIONS ON PAGES 2, 3, and 4.**

1. Never make these cuts FREEHAND (without

using the rip fence or auxiliary devices when required) because the blade could bind in the cut and cause a KICKBACK.

2. Always lock the rip fence securely when in use.
3. Remove miter gauge from table.
4. Make sure blade guard is installed for all thru-sawing type cuts. Replace the guard IMMEDIATELY following completion of resawing, rabbeting, dadoing, or molding operations.

Frequently check the action of the **ANTIKICKBACK PAWLS** by passing the workpiece alongside of the spreader while saw is OFF.

Pull the workpiece **TOWARD** you. If the **PAWLS** do not **DIG** into the workpiece and **HOLD** it . . . the pawls must be **SHARPENED**. See "Maintenance" section.

5. Have blade extend approximately 1/8 in. above top of workpiece. Additional blade exposure would increase the hazard potential.
6. Do not stand directly in front of the blade in case of a **KICKBACK**. Stand to either side of the blade.
7. Keep your hands clear of the blade and out of the path of the blade.
8. If the blade stalls or stops while cutting, **TURN SWITCH OFF** before attempting to free the blade.

9. Do not reach over or behind the blade to pull the workpiece through the cut . . . to support long or heavy workpieces . . . to remove small cut-off pieces of material or **FOR ANY OTHER REASON**.

10. Do not pick up small pieces of cut-off material from the table. **REMOVE** them by pushing them **OFF** the table with a long stick. Otherwise they could be thrown back at you by the rear of the blade.

11. Do not remove small pieces of cut-off material that may become **TRAPPED** inside the blade guard while the saw is **RUNNING**. **THIS COULD ENDANGER YOUR HANDS** or cause a **KICKBACK**.

Turn the saw **OFF**. After the blade has stopped turning, lift the guard and remove the piece.

## RIPPING

**RIPPING** is known as cutting a piece of wood with the grain, or lengthwise. This is done using the rip fence.

Position the fence to the desired **WIDTH OF RIP** and lock in place.

Before starting to rip, be sure

- A. Rip Fence is parallel to sawblade.
- B. Spreader is properly aligned with sawblade.
- C. Antikickback pawls are functioning properly.

When ripping **LONG BOARDS** or **LARGE PANELS**, always use a work support.

A simple one can be made by clamping a piece of plywood to a sawhorse.

## BEVEL RIPPING

When bevel ripping material 6 in. or narrower, use fence on the right side of the blade **ONLY**. This will provide more space between the fence and the sawblade for use of a push stick. If the fence is mounted to the left, the sawblade guard may interfere with proper use of a push stick.

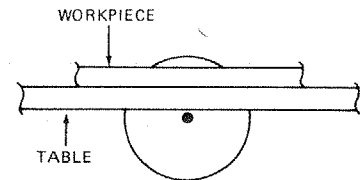

**ALWAYS SUPPORT LONG WORKPIECES**

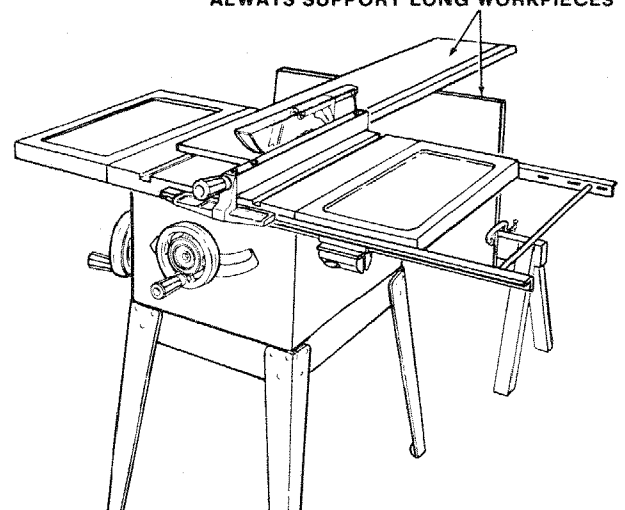

When "**WIDTH OF RIP**" is 6 in. and **WIDER** use your **RIGHT HAND** to feed the workpiece until it is clear of the table.

Use **LEFT hand ONLY** to guide the workpiece . . . do not **FEED** the workpiece with the left hand.

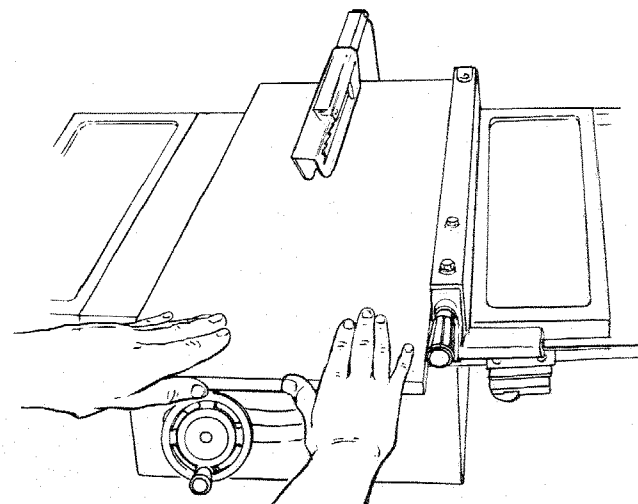

When "WIDTH OF RIP" is 2 in. to 6 in. wide USE THE PUSH STICK to feed the work.

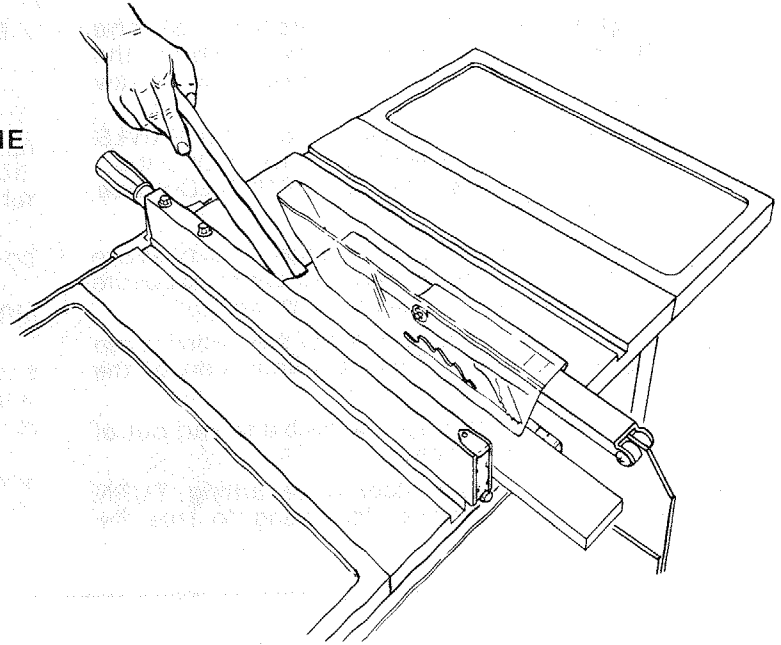

When WIDTH OF RIP is NARROWER than 2 in., the push stick CANNOT be used because the guard will interfere . . . USE the AUXILIARY FENCE/WORK SUPPORT and PUSH BLOCK.

Attach Auxiliary Fence/Work Support to rip fence with two "C" clamps.

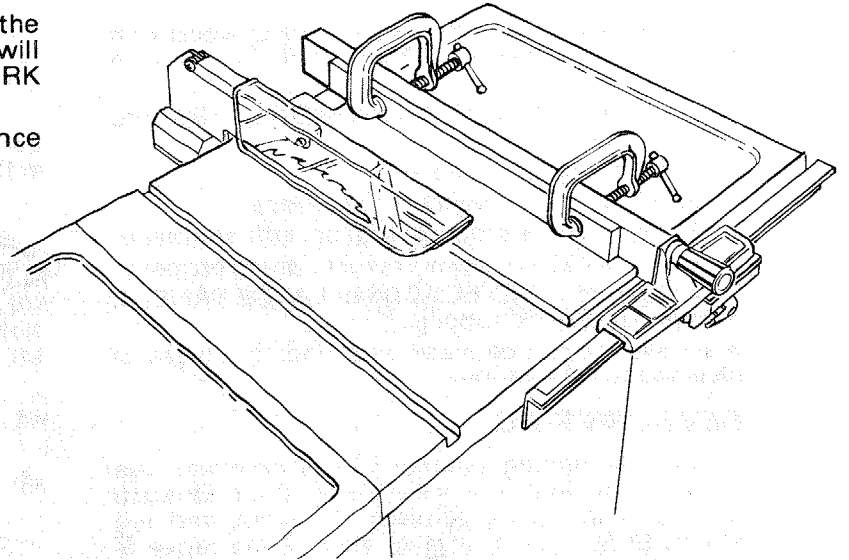

Feed the workpiece by hand along the AUXILIARY FENCE until the end is approx. 1 in. past the front edge of the table. Continue to feed using the PUSH BLOCK.

Hold the workpiece in position and install the PUSH BLOCK by sliding it on top of the AUXILIARY FENCE/WORK SUPPORT (This May Raise Guard).

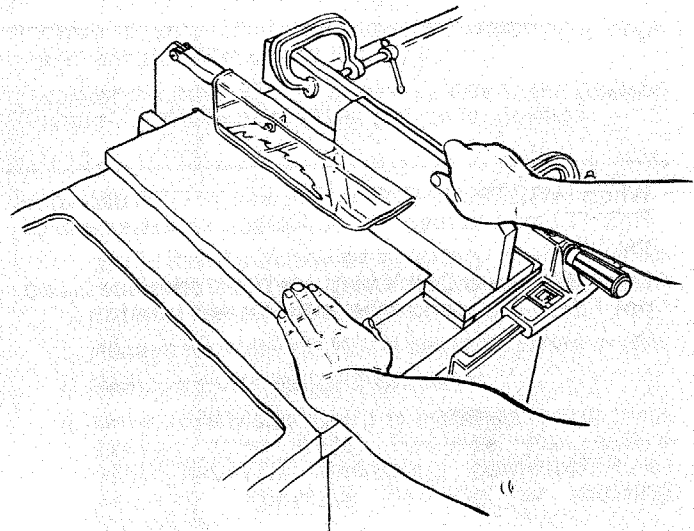

Narrow strips thicker than the Auxiliary Fence/Work Support may enter the guard and strike the baffle. CAREFULLY raise guard only enough to clear the workpiece. Use PUSH BLOCK to complete cut.

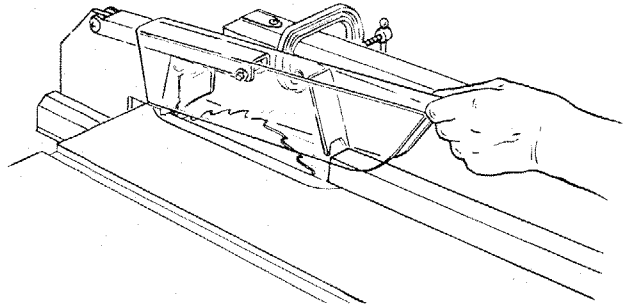
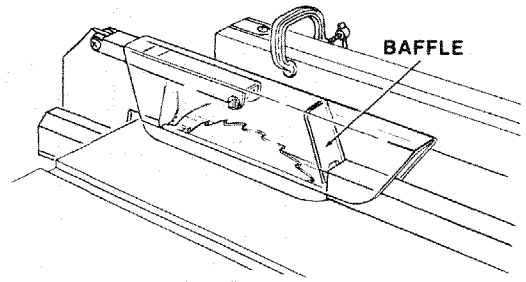

## CUTTING PANELS

When cutting panels (whenever fence is positioned outside of table surface), ALWAYS use the AUXILIARY FENCE/WORK SUPPORT.

1. Unlock fence and raise rear end.
2. Position AUXILIARY FENCE/WORK SUPPORT as shown and attach it with two "C" clamps.

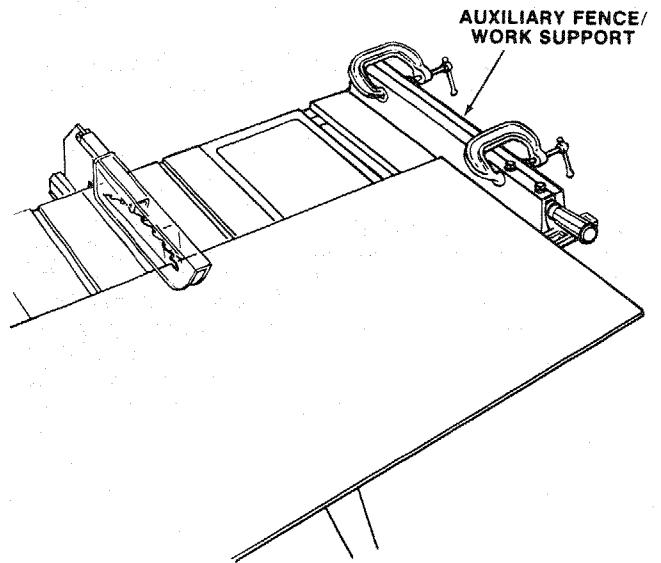

## PLOUGHING AND MOLDING

**PLOUGHING** is grooving with the grain the long way of the workpiece, using the fence. USE proper holddowns and feed devices.

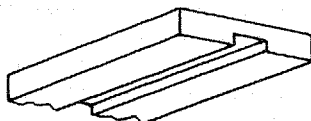

**PLOUGHING**

**MOLDING** is shaping the workpiece with the grain the long way of the workpiece, using the fence. Use proper holddowns and feed devices.

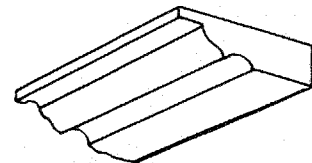

**MOLDING**

## RESAWING

**RESAWING** is a "thru-sawing" cut made by ripping a piece of wood through its thickness. Do not attempt to resaw **BOWED** or **WARPED** material. **NOTE:** To **RESAW** a piece of wood wider than 3-3/8 in. . . . it will be necessary to remove the blade guard . . . and use the **AUXILIARY FENCE/WORK SUPPORT**. (See "Work Helpers").

Clamp it to the table so that the workpiece will **SLIDE EASILY** but not **TILT** or **MOVE SIDEWAYS** between the two fences.

Do not clamp directly to the bottom edge of the table because the "swivel" of the clamp will not grip properly. Place a small block of wood between the bottom edge of the table and the "C" clamp.

**WARNING: FOR YOUR OWN SAFETY . . .**

1. **DO NOT "BACK UP" (REVERSE FEEDING) WHILE RESAWING BECAUSE THIS COULD CAUSE A KICKBACK.**

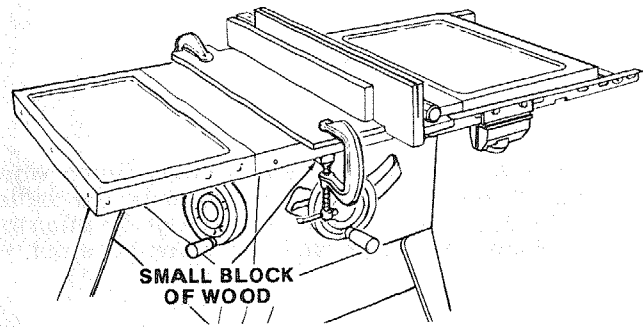

2. **MAKE FIRST PASS TO A DEPTH SLIGHTLY LESS THAN ONE-HALF THE WIDTH OF THE BOARD; KEEP SAME FACE OF BOARD AGAINST FENCE FOR SECOND PASS AS THE FIRST PASS.**
3. **INSTALL BLADE GUARD IMMEDIATELY UPON COMPLETION OF THE RESAWING OPERATION.**

## RABBETING

**RABBETING** is known as cutting out a section of the corner of a piece of material, across an end or along an edge.

To make a **RABBET** requires cuts which do not go all the way through the material. Therefore the blade guard must be removed.

1. Remove blade guard. Use caution. Use featherboards and push sticks, etc. as required.
2. **For rabbeting along an edge** (long way of workpiece) as shown, add facing to rip fence approximately as high as the workpiece is wide. Adjust rip fence and blade to required dimensions; then make first cut with board flat on table as any rip (type) cut; make second cut with workpiece on edge. Follow all precautions, safety instructions, and operational instructions as for ripping, or rip type operations, including featherboards and push stick, etc.
3. **For rabbeting across an end**, for workpiece 10-1/2" and narrower make the rabbet cut with the board flat on the table using the miter gauge fitted with a facing. **DO NOT** use the rip fence.

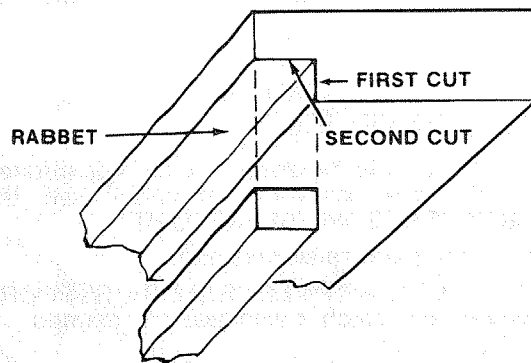

**WARNING: FOR YOUR OWN SAFETY, INSTALL BLADE GUARD IMMEDIATELY UPON COMPLETION OF RABBETING OPERATION.**

Rabbet cuts can also be made using the dado head or molding head.

## DADOING

Instructions for operating the Dado Head are contained in booklet furnished with the Dado Head.

The Recommended Dado Head is listed under Recommended Accessories in this manual.

The arbor on the saw, is only long enough so that the widest cut that can be made is 13/16" wide.

It is not necessary to install the outside loose collar before screwing on the arbor nut. Make sure the arbor nut is tight.

**ALWAYS USE DADO INSERT LISTED UNDER RECOMMENDED ACCESSORIES.**

When using the dado head it will be necessary to remove the Blade Guard and Spreader. **USE CAUTION. USE FEATHERBOARDS AND PUSH STICKS AS REQUIRED.**

**WARNING: FOR YOUR OWN SAFETY, ALWAYS REPLACE THE BLADE GUARD AND SPREADER WHEN YOU ARE FINISHED DADOING.**

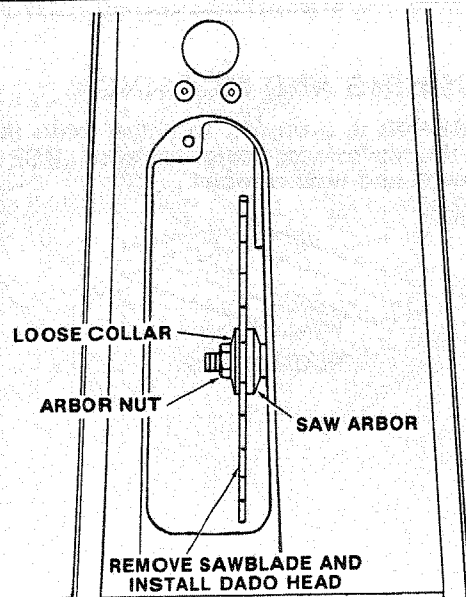

## MOLDING CUTTING

Instructions for operating the Molding Head are contained in a booklet furnished with the Molding Head.

The recommended molding head is listed under Recommended Accessories in this manual.

**Always use Molding Insert Listed Under Recommended Accessories.**

When using the molding head it will be necessary to remove the Blade Guard and Spreader. **USE CAUTION. USE FEATHERBOARDS AND PUSH STICKS, etc. AS REQUIRED.**

**WARNING: FOR YOUR OWN SAFETY, ALWAYS REPLACE THE BLADE GUARD AND SPREADER WHEN YOU ARE FINISHED MOLDING.**

## USING FEATHERBOARDS

Featherboards are **not** employed during non thru-sawing operations when using the miter gauge.

**Use featherboards for all other non "thru-sawing" operations** (when sawblade guard must be removed). Featherboards are used to keep the work in contact with the fence and table as shown, and to stop kickbacks.

Add 8 inch high flat facing board to the fence, the full length of the fence.

Mount featherboards to fence and table as shown, so that leading edges of featherboards will support workpiece until cut is complete, and the workpiece

has been pushed completely past the cutter (sawblade, dado head, molding head, etc.) with a pushstick, as in ripping.

Before starting the operation (switch "OFF" and cutter below table surface):

- Install featherboards so they exert pressure on the workpiece; be positive they are secure, and
- Make sure by trial that the featherboards will stop a kickback if one should occur.

Replace the sawblade guard as soon as the non thru-sawing operation is complete.

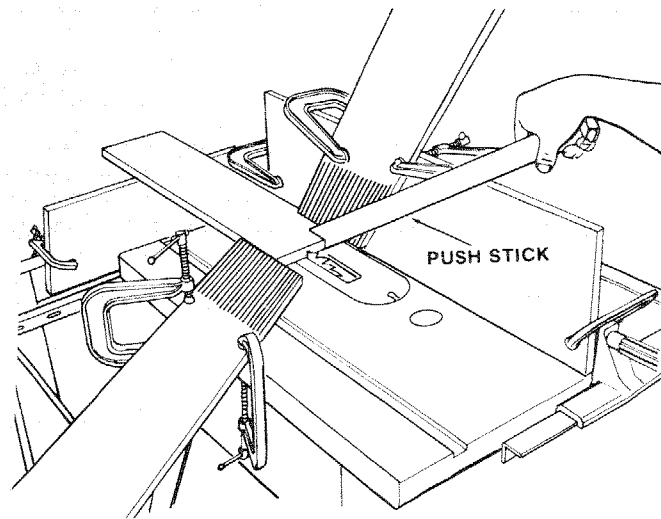
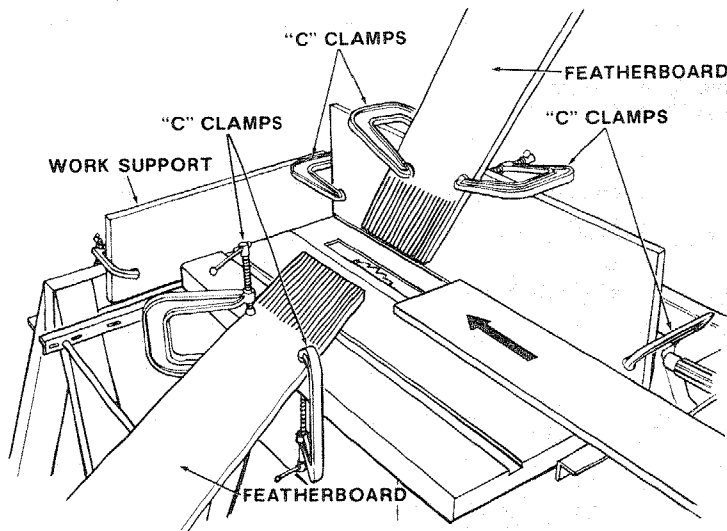

## MOTOR

### LUBRICATION AND MAINTENANCE

- The bearings, in both end shields of the motor, have been lubricated at the factory with correct lubricant. No other part of the motor requires lubrication.
- Re-lubricate motor bearings in accordance with the instructions on the nameplate. Be sure to wipe off dirt or grit if present around oil hole caps to prevent any possibility of foreign material contaminating the oil wicks that supply the bearings with oil. Use a good grade of medium weight mineral oil, such as automobile engine oil, SAE 20.
- If disassembly of the motor is necessary, it should be returned to your nearest Sears retail or mail-order store in order to prevent voiding the guarantee.

**NOTE:** The speed of this motor cannot be regulated or changed.

- Every effort should be made to prevent foreign material from entering the motor. When operated under conditions likely to permit accumulations of dust, dirt, or waste within the motor, a visual inspection should be made at frequent intervals. Accumulations of dry dust can usually be blown out successfully.

**NOTE:** Motors used on wood-working tools are particularly susceptible to the accumulation of sawdust and wood chips and should be blown out or "vacuumed" frequently to prevent interference with normal motor ventilation and proper operation of the centrifugally-operated starting switch.

# MAINTENANCE

**WARNING: TO AVOID INJURY, TURN SWITCH "OFF" AND REMOVE PLUG FROM POWER SOURCE OUTLET BEFORE MAINTAINING OR LUBRICATING YOUR SAW.**

Do not allow sawdust to accumulate inside the saw.

Frequently blow out any dust that may accumulate inside the saw cabinet and the motor.

Frequently clean your cutting tools with Craftsman Gum and Pitch Remover.

A coat of automobile-type wax applied to the table will help to keep the surface clean and allow workpieces to slide more freely.

If the power cord is worn or cut, or damaged in any way, have it replaced immediately.

Make sure the teeth of the ANTIKICKBACK pawls are always sharp. To sharpen:

1. Identify the dull tooth or teeth. Remove blade guard.
2. Rotate pawl toward rear of spreader so that teeth are above top of spreader.

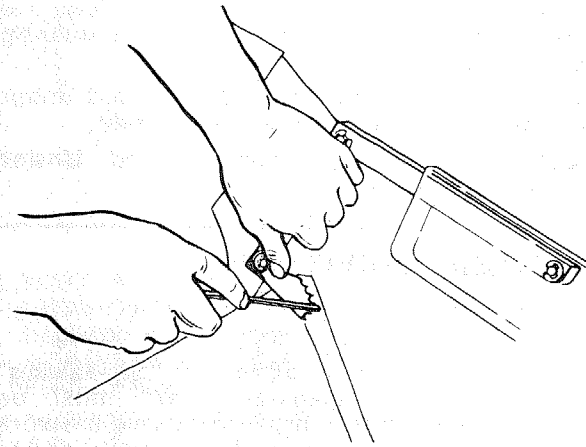

3. Hold spreader with left hand and place pawl over corner of workbench.
4. Sharpen the dull tooth using a few light strokes of a fine-cut round file.

# LUBRICATION

The saw motor bearings have been packed at the factory with proper lubricant and require no additional lubrication. The following parts should be oiled occasionally with SAE No. 20 or No. 30 engine oil.

1. Tilt screw threads and pivot nut. (First Clean with Craftsman Gum & Pitch Remover.)

2. Elevation screw threads and pivot nut. (First Clean with Craftsman Gum & Pitch Remover.)
3. Cradle bearing points.
4. Bearing points in guard assembly, miter gauge and rip fence.

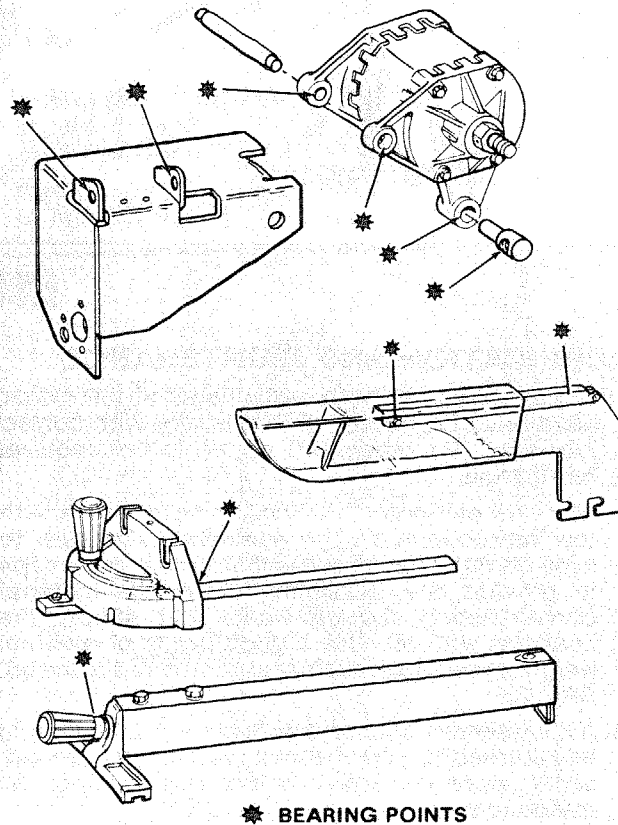
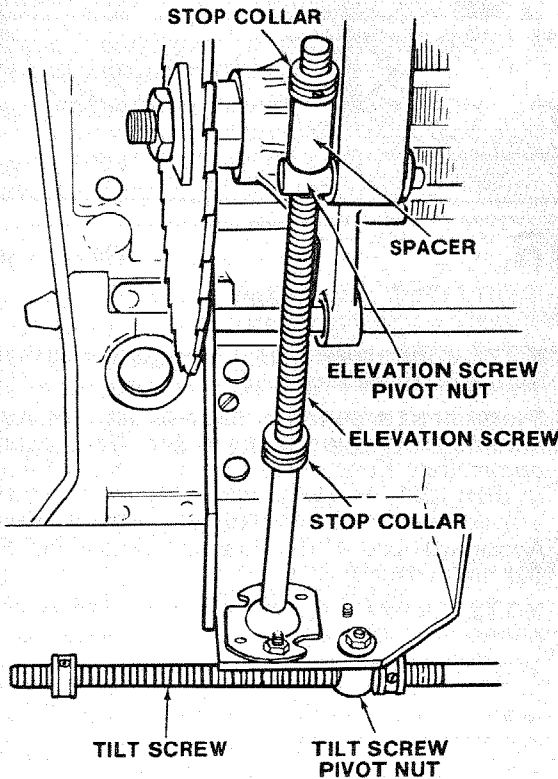

# RECOMMENDED ACCESSORIES

ITEM	CAT. NO.	ITEM	CAT. NO.
Steel Legs .....	9-22235	7 in. Dia. Adjustable Dado Head . . .	9-3261, 9-3262 & 9-3263
Steel Stand .....	9-22214	7 in. Dia. Dado Head .....	9-3257
Caster Sets .....	9-22222 or 9-22221	Sanding Wheel .....	9-2274
Solid Table Extension .....	9-29954	Miter-Gauge Stop Rods .....	9-29924
*7 in. Molding Head Set .....	9-3217 or 9-3218	Miter-Gauge Hold-Down Clamp .....	9-29928
*7 in. Molding Head .....	9-3214	Taper Jig .....	9-3233
Molding/Dado Insert for 7 in. Dia. Molding or dado Head .....	9-29933	Universal Jig .....	9-3231
Work Light .....	9-2480	"Power Tool Know How Handbook"	
Work Light .....	9-2481	Table Saw .....	9-2918
Sawdust Collector .....	9-29967		

\*Smaller Dia. Molding Heads cannot be used because they do not provide adequate depth of cut.

The above recommended accessories are current and were available at the time this manual was printed.

## TROUBLE SHOOTING

**WARNING: TO AVOID INJURY, TURN SWITCH "OFF" AND ALWAYS REMOVE PLUG FROM POWER SOURCE OUTLET BEFORE TROUBLESHOOTING.**

### TROUBLE SHOOTING -- GENERAL

TROUBLE	PROBABLE CAUSE	REMEDY
<b>Excessive vibration.</b>	1. Blade out of balance.	1. Discard Blade and use a different blade.
<b>Cannot make square Cut when crosscutting.</b>	1. Miter gauge not adjusted properly.	1. See "Adjusting Miter Gauge."
<b>Cut binds, burns or stalls motor when ripping.</b>	1. Dull blade with improper tooth set. 2. Blade is Heeling. 3. Warped board.  4. Rip fence not parallel to blade. 5. Spreader out of alignment.	1. Sharpen or replace blade.  2. See "Heeling Adjustment . . ." 3. Make sure concave or hollow side is facing "down," feed slowly. 4. See "Aligning Rip Fence" 5. See "Aligning Spreader."
<b>Cut not true at 90° or 45° positions.</b>	1. Stop screws not properly adjusted.	1. See "Blade Tilt", or "Squareness of Blade to Table."
<b>Tilt and elevating handwheel turn hard.</b>	1. Sawdust on threads of tilt screw or elevating screw. 2. Bearing retainers too tight.	1. See "Maintenance and Lubrication" section. 2. See "Tilt Mechanism."



## TROUBLE SHOOTING -- MOTOR

**NOTE:** Motors used on wood-working tools are particularly susceptible to the accumulation of sawdust and wood chips and should be blown out or "vacuumed" frequently to prevent interference with normal motor ventilation.

**NOTE:** The starting relay is a GRAVITY SENSITIVE TYPE. NEVER TURN THE POWER ON WHILE THE SAW IS UPSIDE DOWN AS THIS WILL DAMAGE THE MOTOR.

TROUBLE	PROBABLE CAUSE	REMEDY
<b>Excessive noise.</b>	1. Motor.	1. Have motor checked by qualified service technician. Repair service is available at your nearest Sears store.
<b>Motor fails to develop full power. NOTE: LOW VOLTAGE:</b> (Power output of motor decreases rapidly with decrease in voltage at motor terminals. For example, a reduction of 10% in voltage causes a reduction of 19% in maximum power output of which the motor is capable, and a reduction of 20% in voltage causes a reduction of 36% in maximum power output.)	1. Circuit overloaded with lights, appliances and other motors.  2. Undersize wires or circuit too long.  3. General overloading of power company facilities. (In some sections of the country, demand for electrical power may exceed the capacity of existing generating and distribution systems.)  4. Incorrect fuses or circuit breakers in power line.	1. Do not use other appliances or motors on same circuit when using the saw.  2. Increase wire sizes, or reduce length of wiring. See "Motor Specification and Electrical Requirements" section.  3. Request a voltage check from the power company.  4. Install correct fuses or circuit breakers.
<b>Motor starts slowly or fails to come up to full speed.</b>	1. Low voltage will not trip relay. 2. Windings burned out or open. 3. Starting relay not operating.	1. Request voltage check from the power company. 2. Have motor repaired or replaced. 3. Have relay replaced.

## TROUBLE SHOOTING -- MOTOR (Continued)

TROUBLE	PROBABLE CAUSE	REMEDY
<b>Motor overheats.</b>	<ol style="list-style-type: none"> <li>1. Motor overloaded.</li> <li>2. Improper cooling. (Air circulation restricted through motor due to sawdust.)</li> </ol>	<ol style="list-style-type: none"> <li>1. Feed work slower into blade.</li> <li>2. Clean out sawdust to provide normal air circulation through motor. See "Maintenance and Lubrication" section.</li> </ol>
<b>Starting switch in motor will not operate.</b>	<ol style="list-style-type: none"> <li>1. Burned switch contacts (due to extended hold-in periods caused by low line voltage, etc.)</li> <li>2. Saw not in upright position.</li> <li>3. Loose or broken connectors.</li> </ol>	<ol style="list-style-type: none"> <li>1. Have switch replaced and request a voltage check from the power company.</li> <li>2. Place saw in upright position.</li> <li>3. Have wiring checked and repaired.</li> </ol>
<b>Motor stalls (resulting in blown fuses or tripped circuit breakers).</b>	<ol style="list-style-type: none"> <li>1. Starting relay not operating.</li> <li>2. Voltage too low to permit motor to reach operating speed.</li> <li>3. Fuses or circuit breakers do not have sufficient capacity.</li> </ol>	<ol style="list-style-type: none"> <li>1. Have relay replaced.</li> <li>2. Request voltage check from the power company.</li> <li>3. Install proper size fuses or circuit breakers.</li> </ol>
<b>Frequent opening of fuses or circuit breakers.</b>	<ol style="list-style-type: none"> <li>1. Motor overloaded.</li> <li>2. Fuses or circuit breakers do not have sufficient capacity.</li> <li>3. Starting switch not operating (motor does not reach speed).</li> </ol>	<ol style="list-style-type: none"> <li>1. Feed work slower into blade.</li> <li>2. Install proper size fuses or circuit breakers.</li> <li>3. Have relay replaced.</li> </ol>

**PARTS LIST FOR CRAFTSMAN 10 INCH DIRECT DRIVE SAW  
MODEL NO. 113.226640**

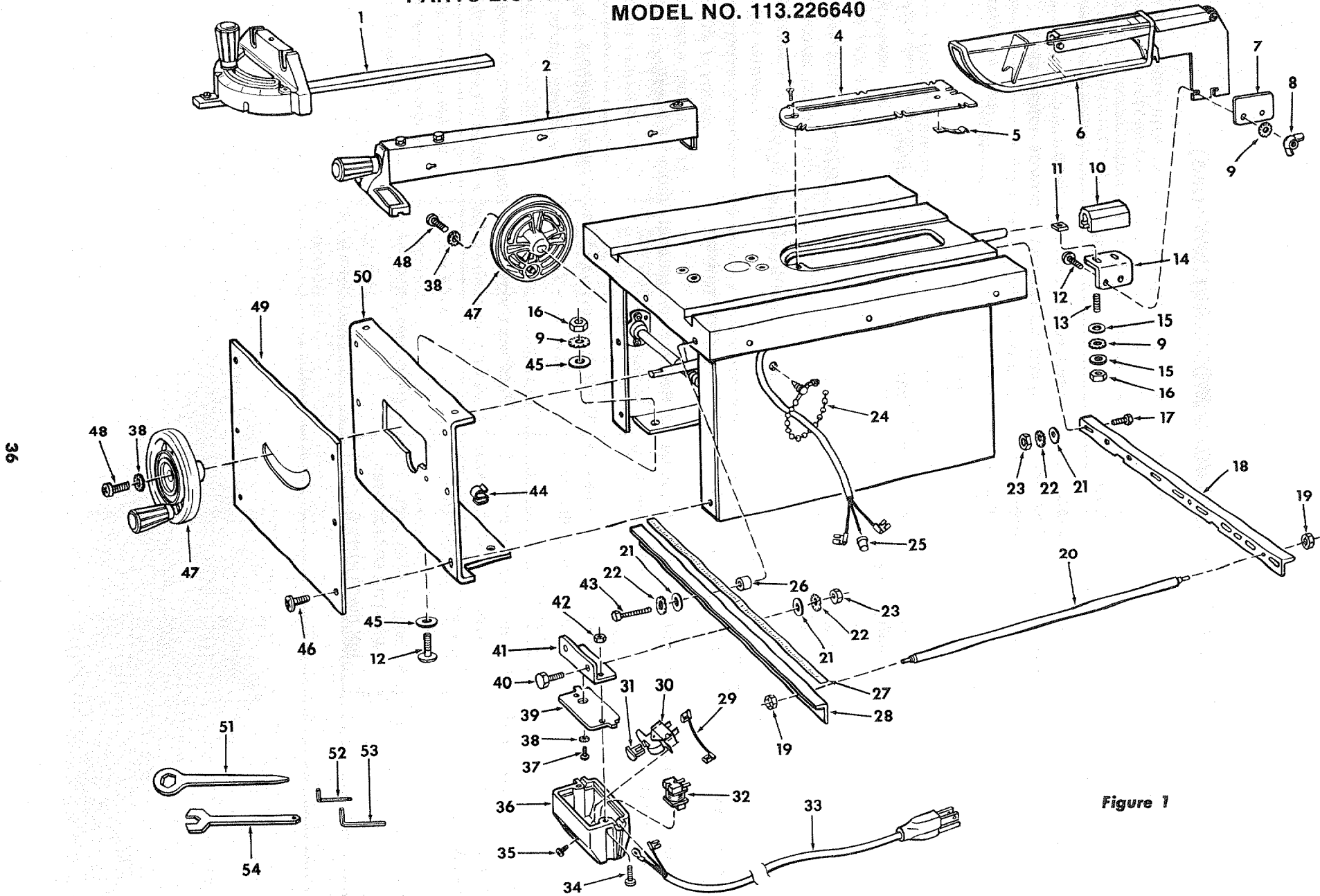

**Figure 1**

**PARTS LIST FOR CRAFTSMAN 10 INCH DIRECT DRIVE SAW  
MODEL NO. 113.226640**

**Always order by Part Number - not by Key Number**

**FIGURE 1 PARTS LIST**

Key No.	Part No.	Description
1	62694	Gauge Assembly, Miter (See Figure 5)
2	62782	Fence Assembly, Rip (See Figure 3)
3	447441	Screw, Flat Hd. Type "T" 10-32 x 7/8
4	62514	Insert Assembly (Includes Key No. 5)
5	62545	Clip, Retaining
6	62805	Guard Assembly (See Figure 6)
7	62643	Clamp, Spreader
8	STD541625	*Nut, Wing 1/4-20
9	STD551225	*Lockwasher, External Tooth 1/4
10	62642	Support, Spreader
11	62636	*Nut, Square 1/4-20
12	60314	Screw, Truss 1/4-20 x 5/8
13	60074	Screw, Set Hex Cup 1/4-20 x 7/8
14	62644	Bracket
15	STD551012	*Washer, 17/64 x 9/16 x 1/16
16	STD541025	*Nut, Hex 1/4-20
17	STD523110	Screw, Hex Hd. 5/16-18 x 1
18	62541	Bar, Fence Rear
19	60388	Nut, Self Threading
20	62770	Rod, Separation (Includes Key No. 18)
21	STD551031	*Washer, 21/64 x 5/8 x 1/16
22	STD551231	*Lockwasher, External Tooth 5/16
23	STD541231	*Nut, Hex 5/16-18
24	71165	Tie, Wire
25	STD375006	*Connector, Wire
26	62539	Spacer, Fence Guide Bar
27	62710	Tape, Fence
28	62709	Bar Assembly, Fence Guide (Includes Key No. 27)
29	62936	Lead Assembly
30	62442	Switch, Locking

Key No.	Part No.	Description
31	60256	Key, Switch
32	62975	Relay
33	67085	Cord with Plug
34	STD511105	*Screw, Pan Cross 10-32 x 1/2
35	STD600603	*Screw, Pan Cross Type "T" 6-32 x 3/8
36	62970	Housing, Switch
37	STD601103	*Screw, Pan Rec. Type "T" 10-32 x 3/8
38	STD551210	*Lockwasher, External No. 10
39	62924	Plate, Switch
40	STD523107	*Screw, Hex Hd. 5/16-18 x 3/4
41	62968	Bracket, Switch
42	STD541411	*Locknut, Hex 10-32
43	STD523115	*Screw, Hex 5/16-18 x 1-1/2
44	62204	Clip, Cord
45	STD551025	*Washer, 17/64 x 47/64 x .062
46	STD610805	*Screw, Pan Hd., Type "AB" No. 8 x 1/2
47	62689	Handwheel Assembly
48	STD511107	*Screw, Pan Cross 10-32 x 3/4
49	62973	Panel, Trim
50	62972	Panel, Front
51	3540	Wrench, Arbor
52	37887	Wrench, Hex "L" 1/8
53	60096	Wrench, Hex "L" 3/16
54	63062	Wrench, Shaft
—	62978	Bag of Loose Parts (Not Illustrated)
—	62980	Bag of Loose Parts (Not Illustrated)
—	62981	Bag of Loose Parts (Not Illustrated)
—	62982	Bag of Loose Parts (Not Illustrated)
—	62983	Bag of Loose Parts (Not Illustrated)
—	62984	Bag of Loose Parts (Not Illustrated)
—	507421	Bag of Loose Parts (Not Illustrated)
—	62969	Owners Manual (Not Illustrated)

\*Standard Hardware Item - May be Purchased  
Locally.

# PARTS LIST FOR CRAFTSMAN 10 INCH DIRECT DRIVE SAW MODEL NO. 113.226640

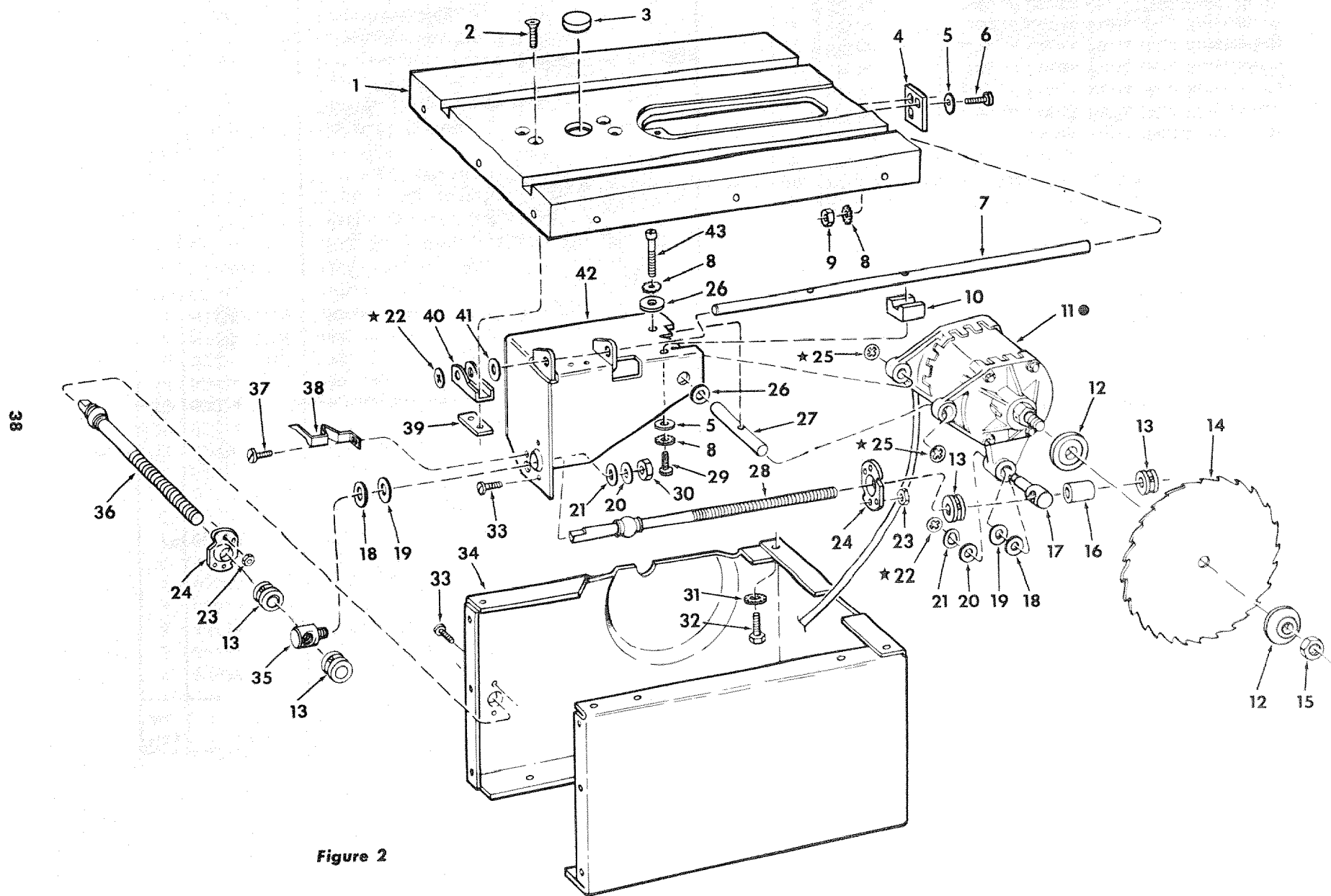

Figure 2

**PARTS LIST FOR CRAFTSMAN 10 INCH DIRECT DRIVE SAW  
MODEL NO. 113.226640**

**FIGURE 2 PARTS LIST**

Key No.	Part No.	Description
1	62977	Table, Saw
2	805297-1	Screw, Flat Hd. 5/16-18 x 1-1/4
3	62493	Insert, Exact-I-Cut
4	62976	Support, Rod
5	STD551010	*Washer, 7/32 x 7/16 x 1/16
6	STD511110	*Screw, Pan Cross 10-32 x 1
7	62624	Rod, Cradle
8	STD551210	*Lockwasher, External Tooth No. 10
9	STD541110	*Nut, Hex No. 10-32
10	62792	Spacer, Cradle Rod
11	62962	•Motor
12	62498	Collar, Blade
13	62683	Collar, Stop L.H.
14	60175	+Blade, Saw 10 inch
15	6362	Nut, Arbor
16	60303	Spacer
17	62681	Nut, Elevation Pivot
18	60328	Washer, Nylon
19	62647	Washer, Rubber
20	62648	Washer, Rubber
21	STD551037	*Washer, .380 x 47/64 x 1/16

Key No.	Part No.	Description
22	60301	★Ring, Retaining 3/8
23	STD541411	*Nut, Lock 10-32
24	62437	Retainer, Bearing
25	60436	★Ring, Retaining 7/16
26	60076	Washer, .505 x 1-1/8 x 1/16
27	62796	Rod, Motor (Includes Key #25)
28	62682	Screw Assembly, Elevation
29	STD511110	*Screw, Pan Rec. 10-32 x 1
30	STD541425	*Nut, Lock 1/4-20
31	STD551131	*Lockwasher, 5/16
32	60078	Screw, Hex Hd. 5/16-18 x 1/2
33	STD511105	*Screw, Pan Hd. 10-32 x 1/2
34	62967	Base, Saw
35	62685	Nut, Bevel Pivot
36	62684	Screw Assembly, Tilt
37	STD600803	*Screw, Type "T" Pan 8-32 x 3/8
38	62686	Indicator, Bevel
39	62436	Nut, Twin
40	62625	Hanger
41	62435	Washer, Thrust 3/8 x 5/8 x 1/16
42	62623	Cradle Assembly
43	436594	Screw, Pan Hd. 10-32 x 1-1/2

\*Standard Hardware Item - May be Purchased Locally.

•Any attempt to repair this motor may create a HAZARD unless repair is done by a qualified service technician. Repair service is available at your nearest Sears Store.

+Stock Item - May be secured through the hardware departments of most Sears Retail Stores or Catalog Order Houses.

★If this part is removed, discard and replace with a new retaining ring.

**PARTS LIST FOR CRAFTSMAN 10 INCH DIRECT DRIVE SAW  
MODEL NO. 113.226640**

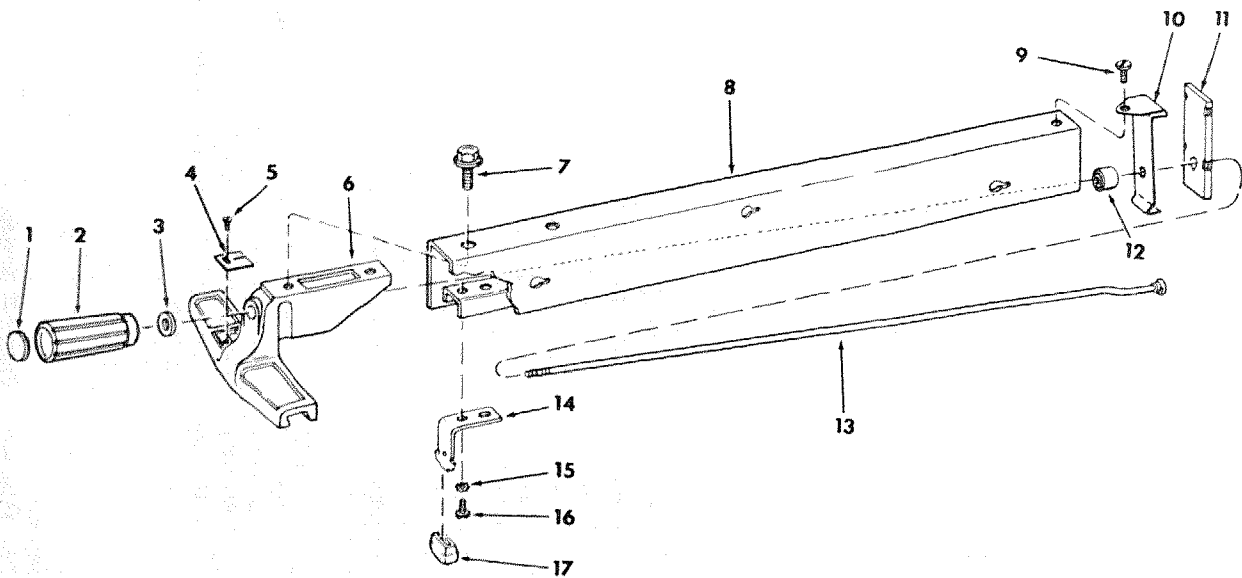
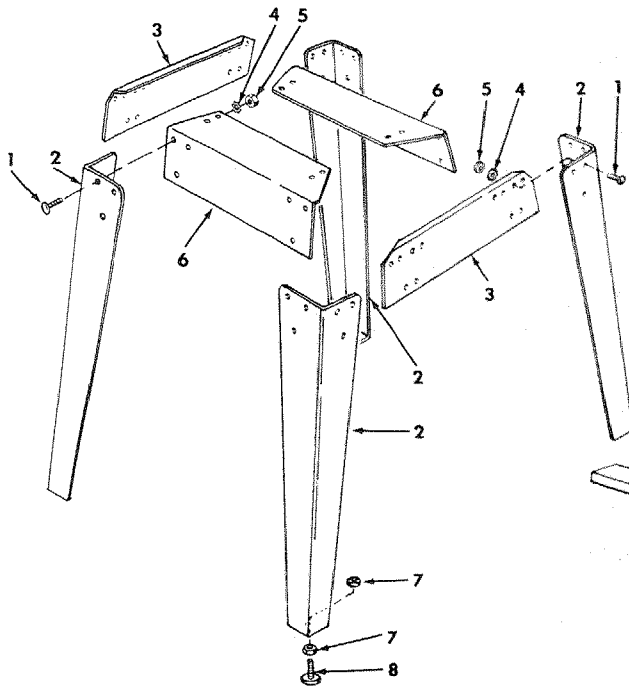

**FIGURE 3 — 62782 FENCE ASSEMBLY**

Key No.	Part No.	Description
-	62782	Fence Assembly, Rip
1	62693	Plug, Button
2	62692	Knob (Includes Key No. 1)
3	STD551031	*Washer, 21/64 x 1/2 x 1/32
4	62775	Indicator, Fence
5	9404336	*Screw, Pan Hd. Type "T" 4-40 x 1/4
6	62774	Head, Fence Includes Key #4
7	423350	Screw, Sems 3/8-16 x 1/2
8	62526	Channel, Fence
9	STD600805	Screw, Pan Hd. Type "T" 8-32 x 1/2
10	62528	Spring, Fence Lock
11	62529	Lock, Rear Fence
12	62531	Roller, Rear Fence
13	62530	Rod, Fence Lock
14	62533	Spring, Head Alignment (Includes Key No. 17)
15	STD551210	*Lockwasher, External Tooth No. 10
16	STD611005	*Screw, Type "A" Hex Hd. No. 10 x 1/2
17	62532	Pad, Alignment

\*Standard Hardware Item — May be Purchased Locally.

**PARTS LIST FOR CRAFTSMAN 10 INCH DIRECT DRIVE SAW  
MODEL NO. 113.226640**



**FIGURE 4**

Key No.	Part No.	Description
1	60314	Screw, Serrated Truss Hd. 1/4-20 x 5/8
2	62552	Leg
3	62554	Stiffener, Side
4	STD551225	*Lockwasher, Ext. 1/4
5	STD541025	*Nut, Hex 1/4-20
6	62553	Stiffener, End
7	STD541250	*Nut, Hex 1/2-13
8	803835 62767	Foot, Leveling †Bag of Loose Parts (not illustrated)

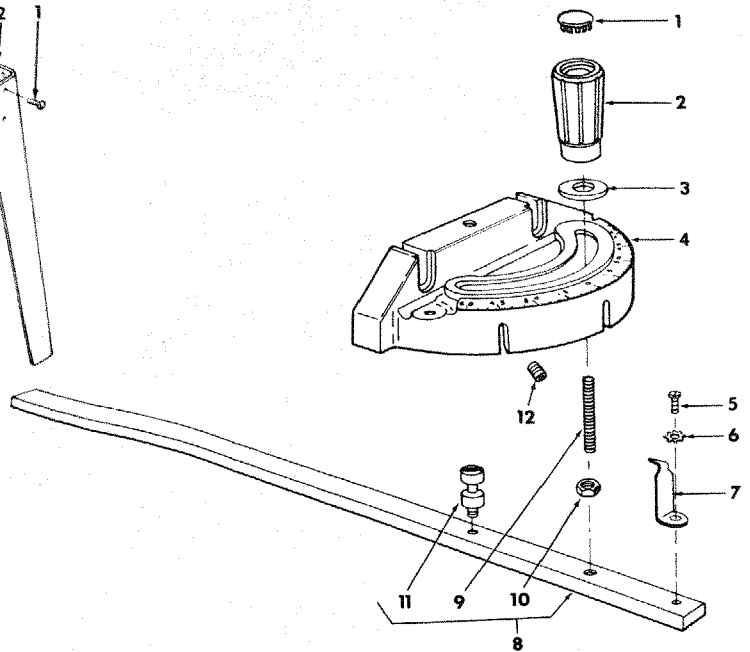

**FIGURE 5  
62694 MITER GAUGE ASSEMBLY**

Key No.	Part No.	Description
-		Miter Gauge Assembly
1	62693	Plug, Button
2	62692	Knob (Includes Key No. 1)
3	STD551031	*Washer, 21/64 x 1 x 1/16
4	37893	Gauge, Miter
5	STD600803	*Screw, Pan Head Type "T" 8-32 x 5/16
6	STD551208	*Lockwasher, External No. 8
7	62042	Indicator
8	62252	Rod Asm., Miter Gauge (Includes Key No. 9, 10, 11)
9	62225	Stud, Clamp
10	STD541231	*Nut, Hex Jam 5/16-18
11	62383	Stud, Pivot
12	60288	Screw, Locking Set, 1/4-20 x 3/8

\*Standard Hardware Items — May be Purchased Locally.

†Bag contains all Loose Parts for Legs.

**PARTS LIST FOR CRAFTSMAN 10 INCH DIRECT DRIVE SAW  
MODEL NO. 113.226640**

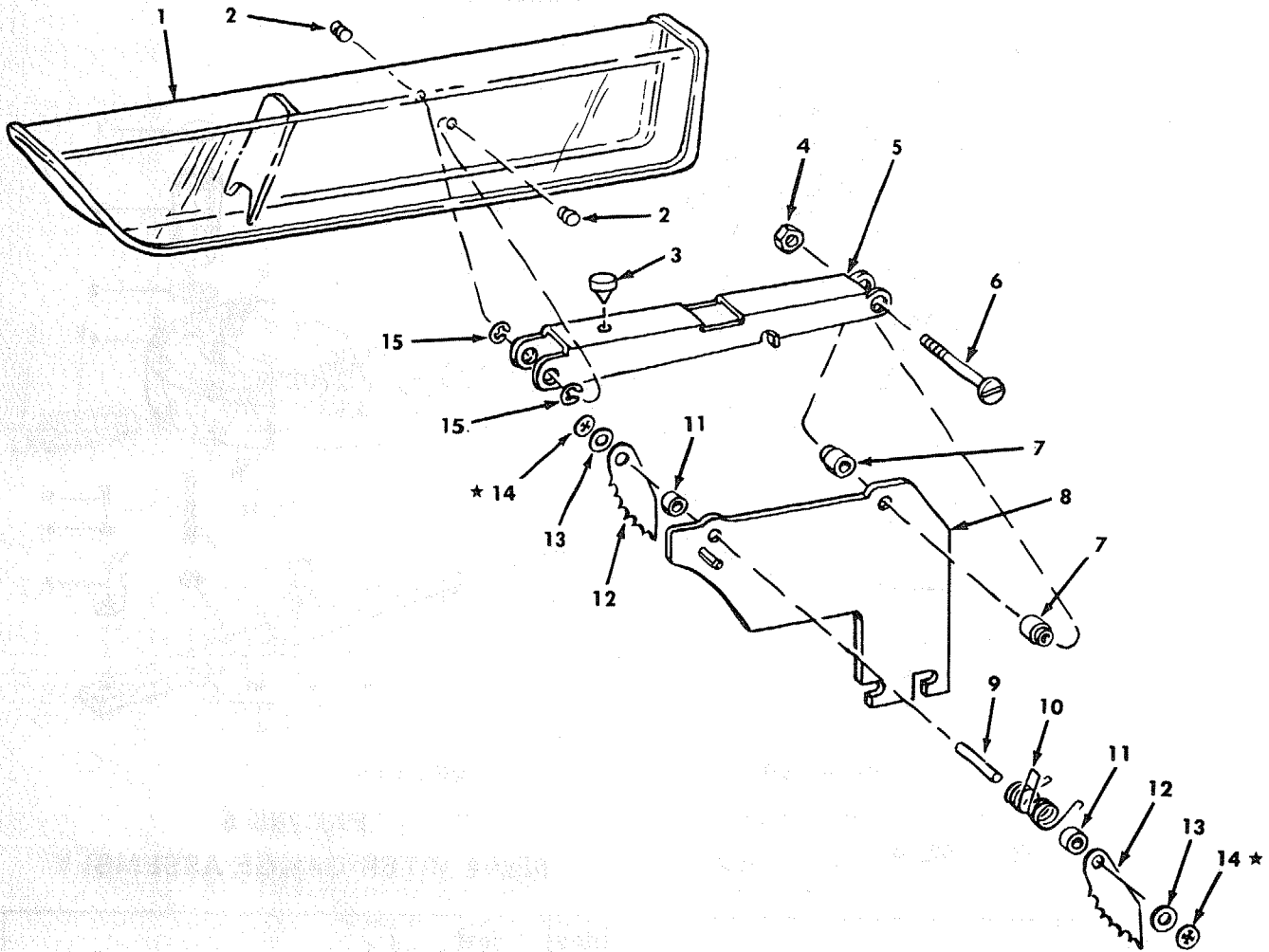
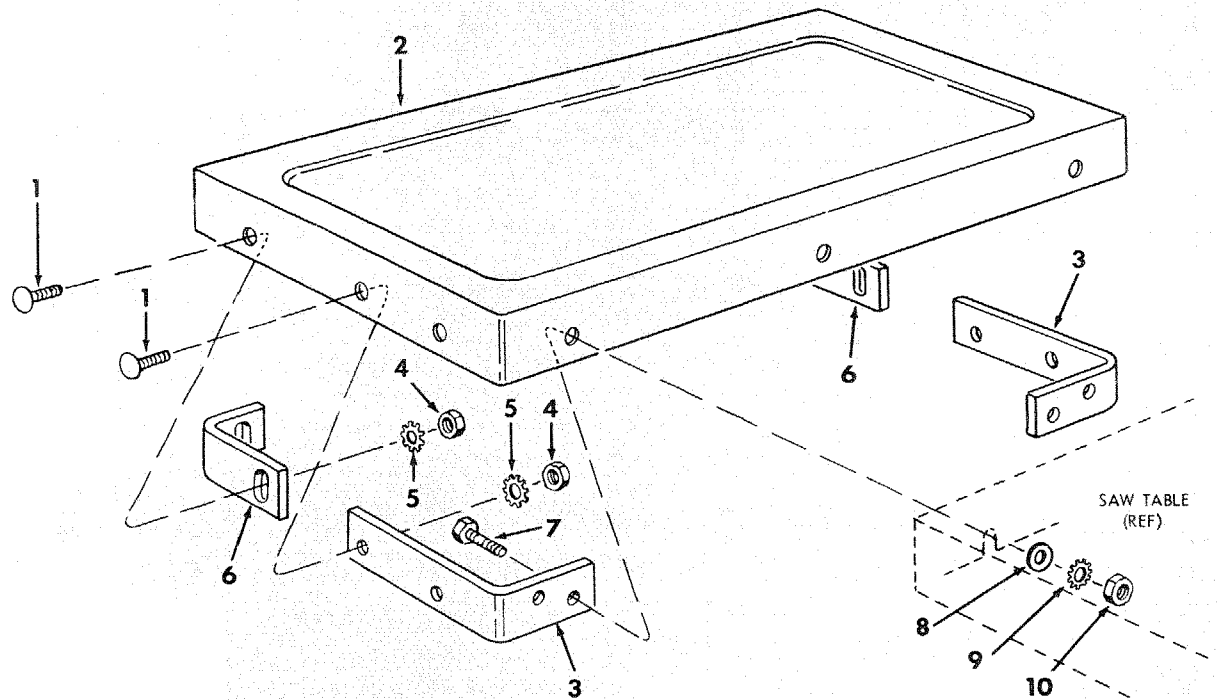

**FIGURE 6 — 62805 GUARD ASSEMBLY**

Key No.	Part No.	Description
-	62805	Guard Assembly
1	62415	Guard
2	62516	Pin
3	62650	Bumper, Snap In
4	STD541425	*Nut, Lock 1/4-20
5	62517	Link, Guard
6	STD512515	*Screw, Pan Hd., 1/4-20 x 1-1/2
7	62522	Spacer, Link
8	62810	Blade, Spreader
9	62410	Pin, 1/4 x 1-3/64
10	62519	Spring, Pawl
11	62520	Spacer, Pawl
12	62974	Pawl
13	STD551012	*Washer, 17/64 x 1/2 x 1/32
14	60297	*Nut, Push
15	STD581025	*Ring, Retaining 1/4

\*Standard Hardware Item — May be Purchased Locally.

**PARTS LIST FOR CRAFTSMAN 10 INCH DIRECT DRIVE SAW  
MODEL NO. 113.226640**



**FIGURE 7 — TABLE EXTENSION**

Key No.	Part No.	Description
-	62546	†Extension Assembly, Complete
1	60323	Screw, Serrated Truss Hd. 1/4-20 x 1"
2	62547	Extension
3	62549	Bracket, Corner Support No. 2
4	STD541025	*Nut, Hex 1/4-20
5	STD551225	*Lockwasher, Ext. 1/4
6	62550	Bracket, Corner Stiffener
7	STD523112	*Screw, Hex Hd. 5/16-18 x 1-1/4
8	STD551031	*Washer, 11/32 x 11/16 x 1/16
9	STD551131	*Lockwasher, Ext. 5/16
10	STD541031	*Nut, Hex 5/16-18

\*Standard Hardware Item - May be Purchased Locally.

†Stock Item - May be secured through the hardware departments of most Sears Retail Stores or Catalog Order House.

# SEARS

*owners  
manual*

## SERVICE

**MODEL NO.  
113.226640**

**SAW WITH LEGS AND  
TWO TABLE EXTENSIONS**

**HOW TO ORDER  
REPAIR PARTS**

## 10 INCH DIRECT DRIVE TABLE SAW

Now that you have purchased your 10-inch table saw should a need ever exist for repair parts or service, simply contact any Sears Service Center and most Sears, Roebuck and Co. stores. Be sure to provide all pertinent facts when you call or visit.

The model number of your 10-inch table saw will be found at the rear of the base.

WHEN ORDERING REPAIR PARTS, ALWAYS GIVE THE FOLLOWING INFORMATION:

PART NUMBER	PART DESCRIPTION
MODEL NUMBER 113.226640	NAME OF ITEM 10-INCH DIRECT DRIVE TABLE SAW

All parts listed may be ordered from any Sears Service Center and most Sears stores. If the parts you need are not stocked locally, your order will be electronically transmitted to a Sears Repair Parts Distribution Center for handling.

**Sold by SEARS, ROEBUCK AND CO., Chicago, IL. 60684 U.S.A.**