

# Griddle/Equipment Stands with Adjustable Undershaft

## ASSEMBLY INSTRUCTIONS

### CAUTION

INSPECT CONTENTS IMMEDIATELY AND FILE CLAIM WITH DELIVERING CARRIER FOR ANY DAMAGE. **SAVE YOUR BOX AND ALL PACKING MATERIALS.** YOU ARE RESPONSIBLE FOR DAMAGE TO YOUR UNIT IF RETURNED IMPROPERLY PACKED.

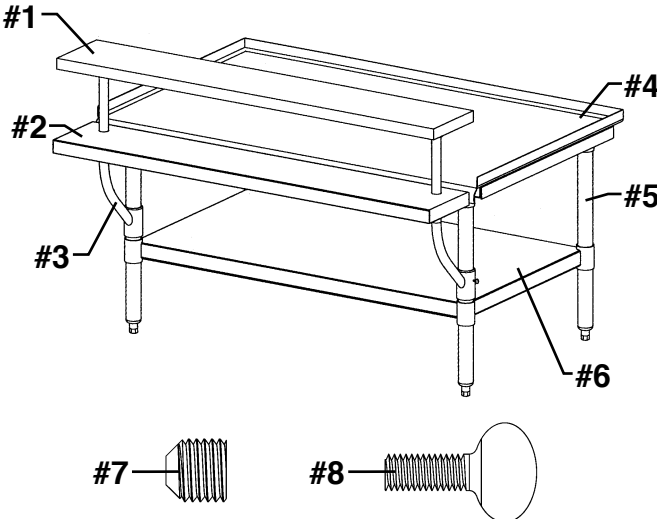

### Parts List

| item # | qty | part # | description                       |
|--------|-----|--------|-----------------------------------|
| #1     | 1   | *      | hardwood cutting board (optional) |
| #2     | 1   | *      | plate shelf (optional)            |
| #3     | 2   | 309762 | leg support** (optional)          |
| #4     | 1   | *      | tabletop                          |
| #5     | 4   | *      | 22 1/2" leg                       |
| #6     | 1   | *      | undershaft                        |

\* Part number varies by size and/or style of table ordered.  
\*\* Leg Support comes with optional hardwood cutting board.

### Hardware List

| item # | qty | part # | description                         |
|--------|-----|--------|-------------------------------------|
| #7     | 8   | 311243 | 5/16-24 set screw                   |
| #8     | 6   | 301546 | 10-32 x 1/2" thumb screw (optional) |

### Step 1 - Assemble legs to undershaft.

- Be sure undershaft is level.
- Recommended height from the floor to the top of the undershaft is 10'.

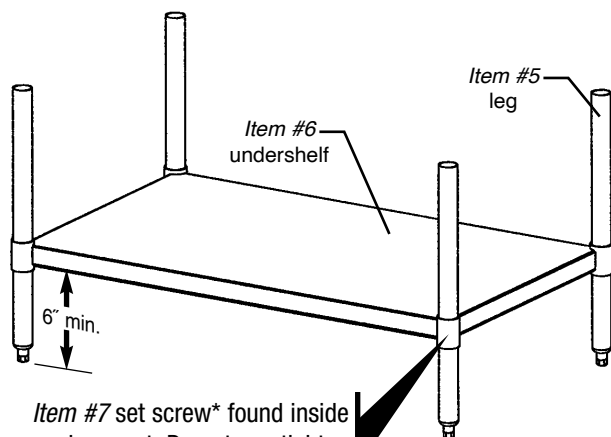

Item #7 set screw\* found inside each gusset. Do not overtighten or failure will occur. Use 5/32" allen wrench (not shown).

**\* To meet NSF standards:**

Set screws must be filled with NSF-approved sealant.

### BEFORE CONTINUING, PLEASE NOTE:

If you ordered optional plate shelf and/or optional hardwood cutting board, proceed to **Step 2**. If not, proceed to **Step 3**.

### Step 2 - Assemble leg supports to front legs at desired location.

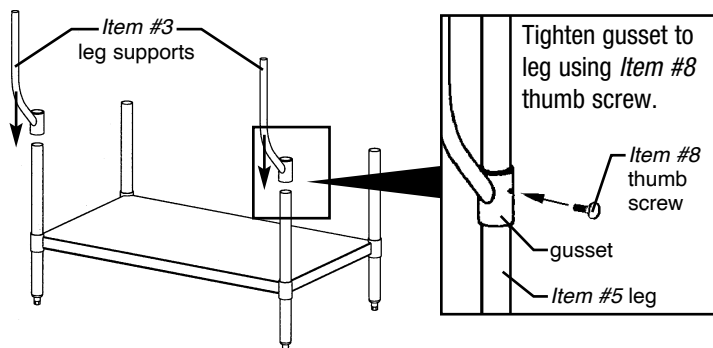

(continued on back page) 

EG9981 Revised 02/23

# Griddle/Equipment Stands with Adjustable Undershelf

## ASSEMBLY INSTRUCTIONS

### Step 3 - Assemble tabletop to leg/undershelf subassembly.

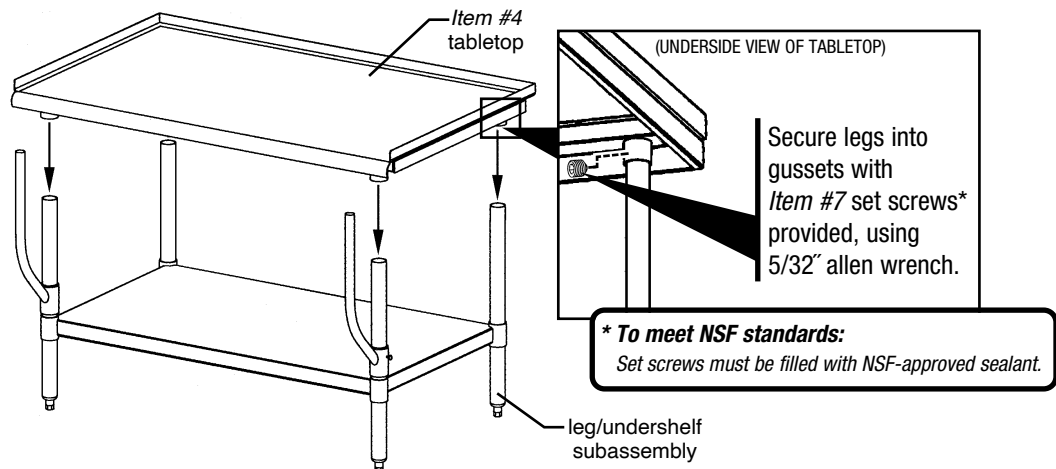

### PLEASE NOTE:

If you ordered optional plate shelf and/or optional hardwood cutting board, proceed below.  
Otherwise, assembly is complete.

### Step 4 - Slide plate shelf over leg supports to desired location.

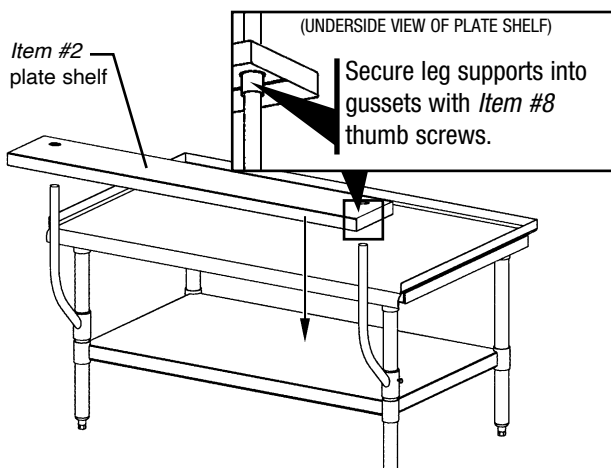

### Step 5 - Set hardwood cutting board onto leg supports.

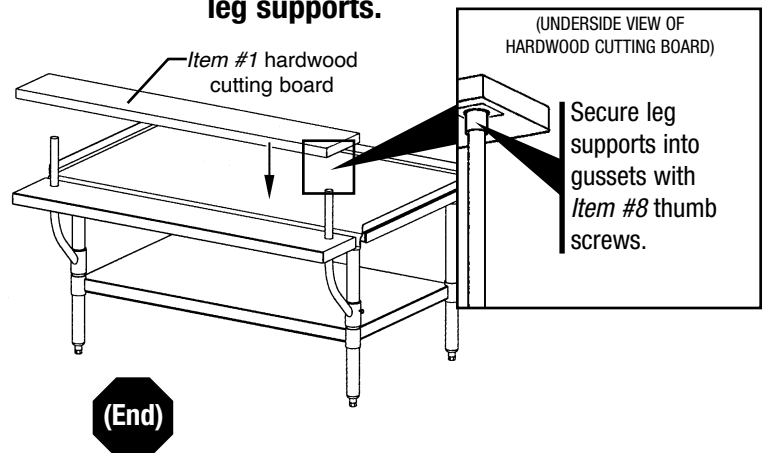

### FOR CLEANING:

1. Wooden cutting boards, butchers blocks, and bakers tables are not intended to be soaked for a prolonged length of time during the cleaning and sanitizing process.
2. Wipe down wood surfaces with warm, soapy water. The top or cutting board should be dried with a rag to insure no standing water remains. Most household cleaners like Windex® or Formula 409® can also be used to clean the top or cutting board\*.
3. Stains can usually be removed with fingernail polish remover or chlorine bleach without damage to the wood surface.
4. The Urethane finish is an exceptionally durable finish. However, NO finish is waterproof. If the wood surface is to be kept immaculate, treat it like a piece of furniture.
5. In most cases, the finish will last for years without further treatment. However, over time, the finish will degrade with continuous use and cutting directly on the surface. If desired, the surface can be sanded down and refinished. We recommend Emmet's "Good Stuff" gel urethane wood finish.

\* Exceptions: Do not use ammonia-based products as they can cloud the finish. Abrasive cleaners and scouring pads can scratch the top.



- 100 Industrial Boulevard, Clayton, Delaware 19938-8903 U.S.A.
- Phone: 302/653-3000 • 800/441-8440 • Fax: 302/653-2065
- www.eaglegrp.com • www.eaglegrpnews.com • www.eaglemhc.com