

Body-Solid®

Built for Life

GLPH1100

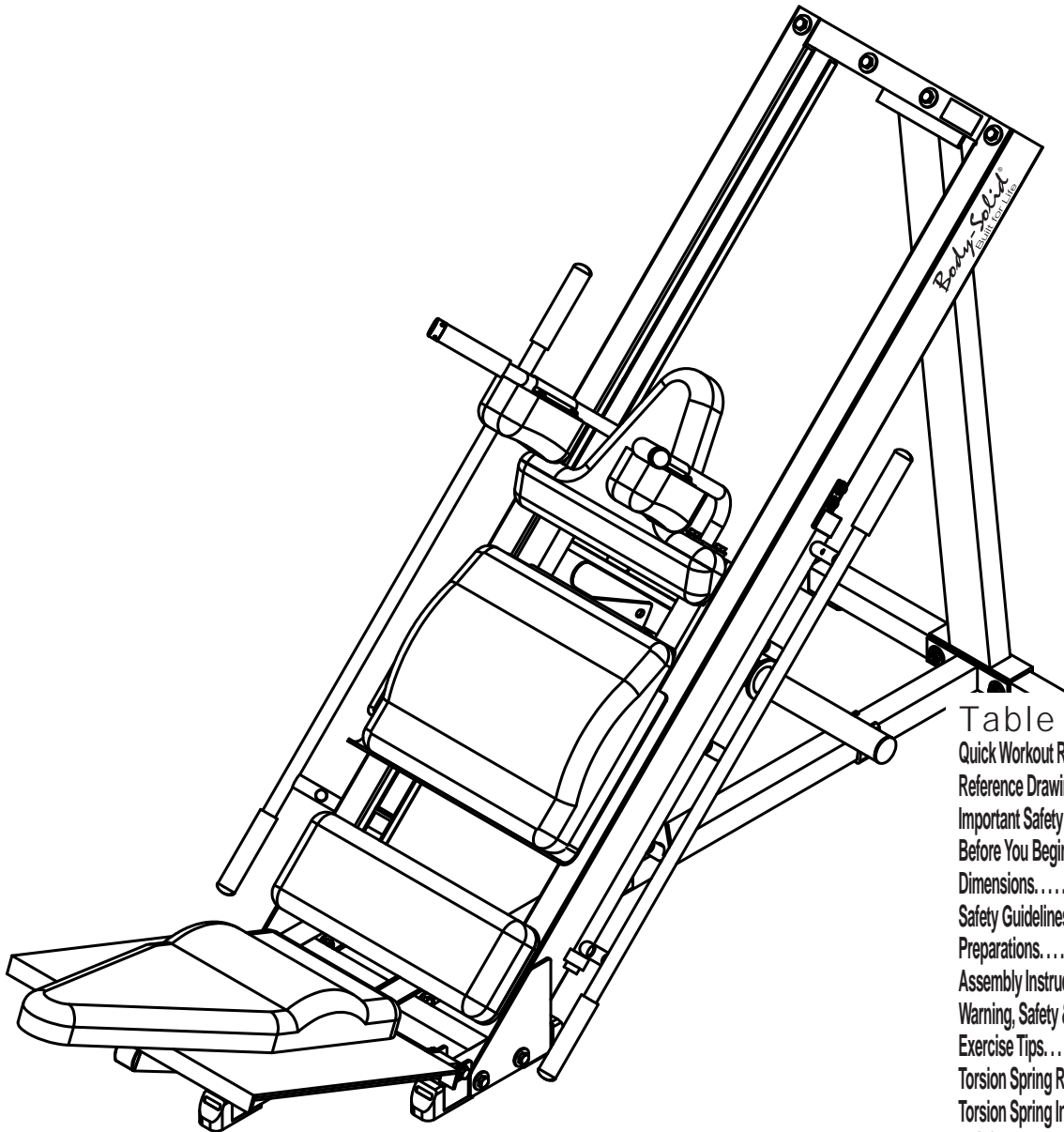

Table of Contents

Quick Workout Reference.....	p. 2
Reference Drawings.....	p. 3
Important Safety Instructions.....	p. 4
Before You Begin.....	p. 5
Dimensions.....	p. 6
Safety Guidelines.....	p. 7
Preparations.....	p. 8
Assembly Instructions.....	p. 9-25
Warning, Safety & Maintenance.....	p. 26-27
Exercise Tips.....	p. 28-47
Torsion Spring Removal.....	p. 48-50
Torsion Spring Installation.....	p. 51-53
Mainframe Parts List.....	p. 54
Hardware List.....	p. 55
Hardware (To Scale).....	p. 56-59
Exploded View Diagram.....	p. 60-61

Assembly & Instructions

OWNER'S & MANUAL

v. 042910

Quick Workout Reference

The GLPH1100 has several adjustments that enable many different and effective workouts. Please see below for a collection of GLPH1100 adjustment references.

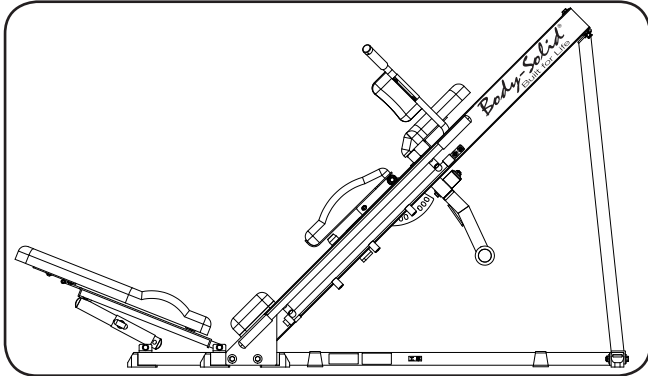

Diagram 1
Squat Press

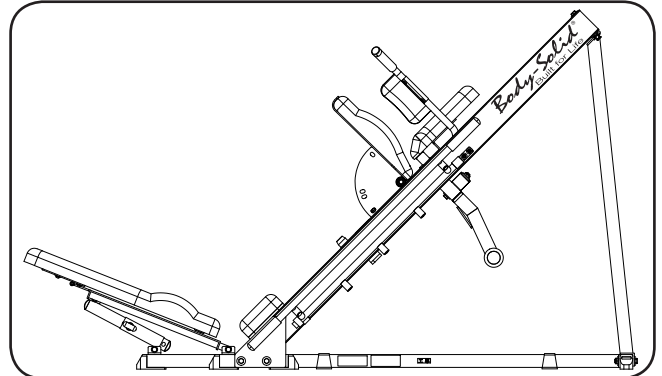

Diagram 4
Leg Press - Position 1

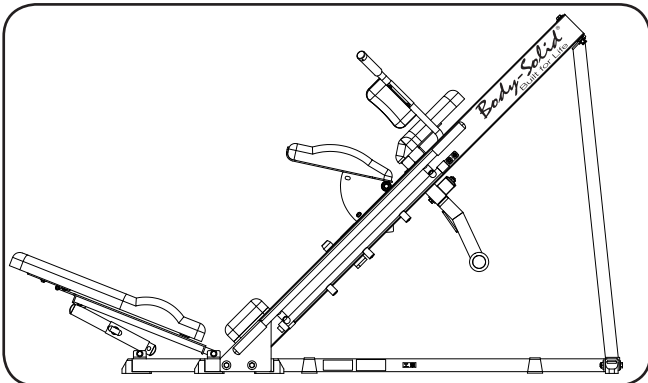

Diagram 2
Calf Press - Position 1

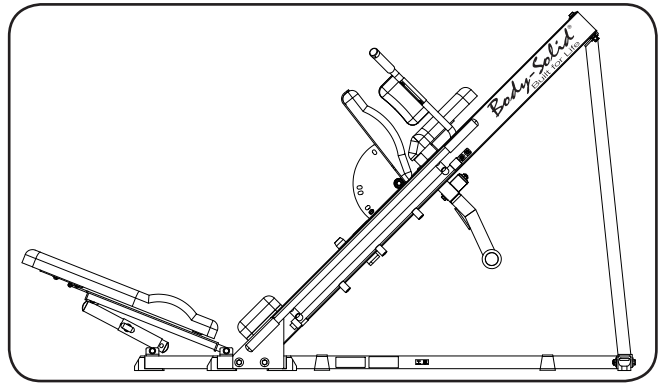

Diagram 5
Leg Press - Position 2

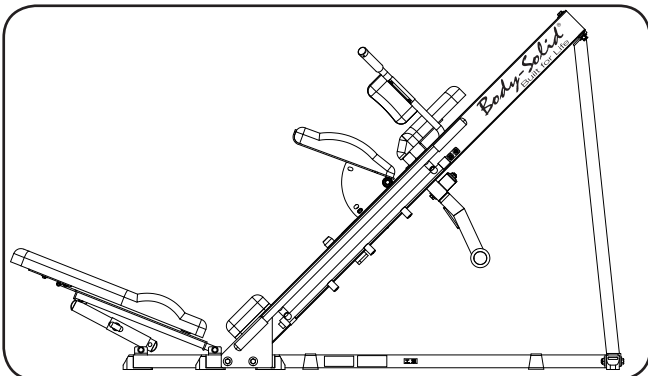

Diagram 3
Calf Press - Position 2

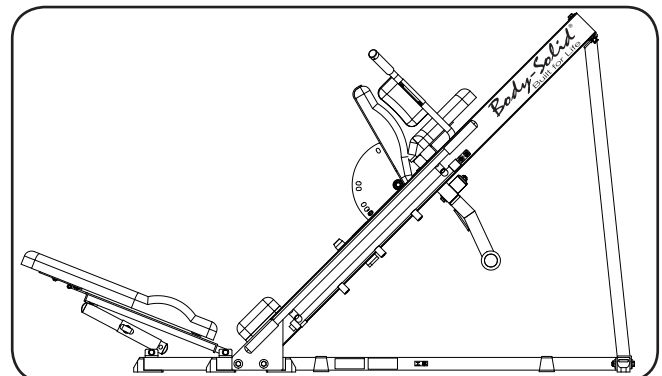
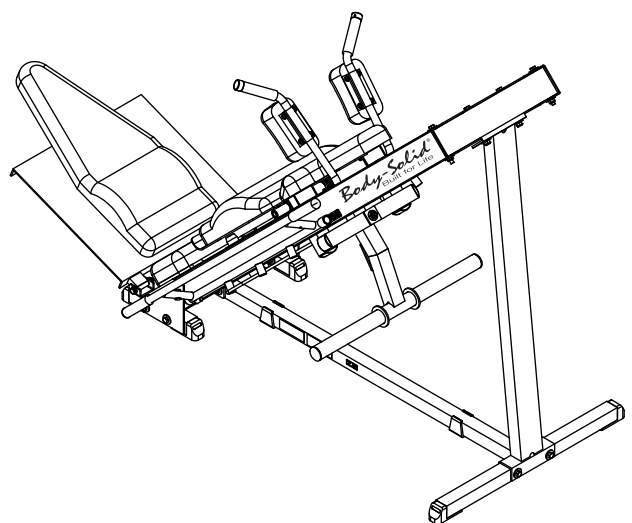
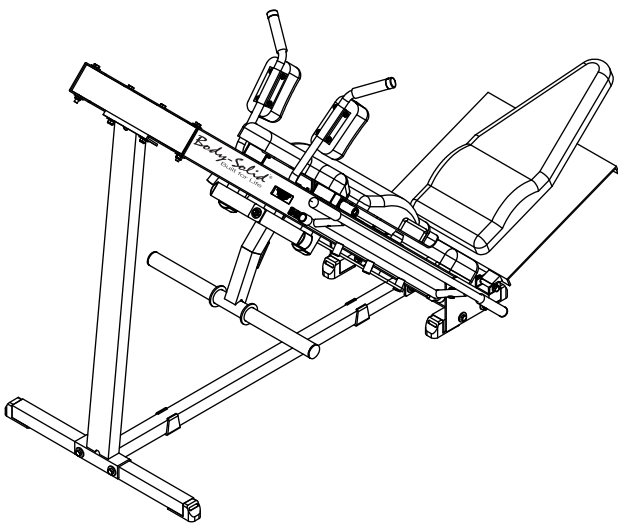
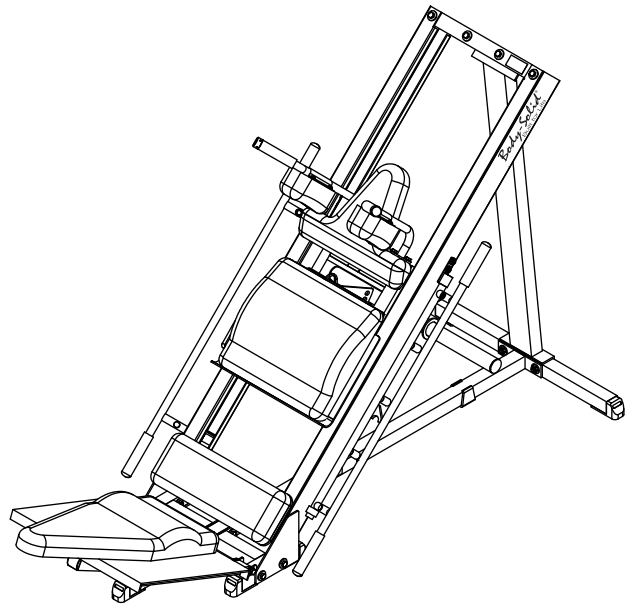
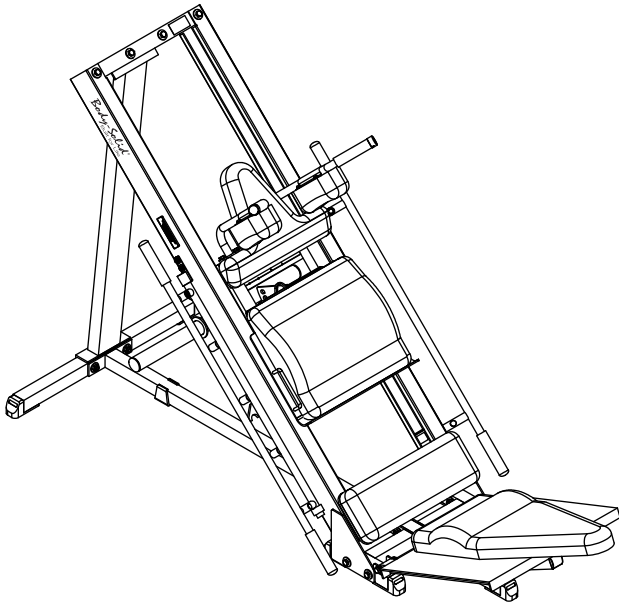

Diagram 6
Leg Press - Position 3

GLPH 1100 Reference Drawings



Note: Due to continuing product improvements, specifications and designs are subject to change without notice.

Even though we have prepared this manual with extreme care, neither the publisher nor the author can accept responsibility for any errors in, or omission from, the information given.

Important Safety Instructions

Before beginning any fitness program, you should obtain a complete physical examination from your physician.

*Il est conseillé de subir un examen médical complet avant d'entreprendre tout programme d'exercice.
Si vous avez des étourdissements ou des faiblesses, arrêtez les exercices immédiatement.*

Antes de comenzar cualquier programa de ejercicios, deberías tener un examen físico con su doctor.

When using exercise equipment, you should always take basic precautions, including the following:

- Read all instructions before using the GLPH1100. These instructions are written to ensure your safety and to protect the unit.
- Do not allow children on or near the equipment.
- Use the equipment only for its intended purpose as described in this guide. Do not use accessory attachments that are not recommended by the manufacturer. Such attachments might cause injuries.
- Wear proper exercise clothing and shoes for your workout, no loose clothing.
- Use care when getting on or off the unit.
- Do not overexert yourself or work to exhaustion.
- If you feel any pain or abnormal symptoms, stop your workout immediately and consult your physician.
- Never operate the unit when it has been dropped or damaged. Return the equipment to a service center for examination and repair.
- Never drop or insert objects into any opening in the equipment.
- Do not use the equipment outdoors or near water.

Personal Safety During Assembly

- It is strongly recommended that a qualified dealer assemble the equipment.
Assistance is required.
- Before beginning assembly, please take the time to read the instructions thoroughly.
- Read each step in the assembly instructions and follow the steps in sequence. Do not skip ahead. If you skip ahead, you may learn later that you have to disassemble components and that you may have damaged the equipment.
- Assemble and operate the GLPH1100 on a solid, level surface. Locate the unit a few feet from the walls or furniture to provide easy access.

The GLPH1100 is designed for your enjoyment. By following these precautions and using common sense, you will have many safe and pleasurable hours of healthful exercise with your Body-Solid GLPH1100.

After assembly, you should check all functions to ensure correct operation. If you experience problems, first recheck the assembly instructions to locate any possible errors made during assembly. If you are unable to correct the problem, call the dealer from whom you purchased the machine or call 1-800-556-3113 for the dealer nearest you.

Obtaining Service

Please use this Owner's Manual to make sure that all parts have been included in your shipment. When ordering parts, you must use the part number and description from this Owner's Manual. Use only Body-Solid replacement parts when servicing this machine. Failure to do so will void your warranty and could result in personal injury.

For information about product operation or service, check out the official Body-Solid website at www.bodysolid.com or contact an authorized Body-Solid dealer or a Body-Solid factory-authorized service company or contact Body-Solid customer service at one of the following:

Toll Free: 1-800-556-3113
Phone: 1-708-427-3555
Fax: 1-708-427-3556
Hours: M-F 8:30-5:00 CST
E-Mail: service@bodysolid.com

Or write to: Body-Solid, Inc.
Service Department
1900 S. Des Plaines Ave.
Forest Park, IL 60130 USA

Retain this Owner's Manual for future reference. Part numbers are required when ordering replacement parts.

Before You Begin

Thank you for purchasing the GLPH1100. This gym is part of the Body-Solid line of quality strength training machines, which let you target specific muscle groups to achieve better muscle tone and overall body conditioning. To maximize your use of the equipment please study this Owner's Manual thoroughly.

Unpacking the Equipment

The GLPH1100 is carefully tested and inspected before shipment. Body-Solid ships the unit in several pieces that require assembly. Ask for assistance during the assembly process.

Carefully unpack the boxes and lay the pieces on the floor near the area where you plan to use the equipment.

Be careful to assemble all components in the sequence presented in this guide.

If any items are missing, contact the dealer from whom you purchased the unit or call 1-800-556-3113 for the dealer nearest you.

Body-Solid continually seeks ways to improve the performance, specifications and product manuals in order to ensure that only superior products are released from our factories. Please take the time to carefully read through this manual thoroughly. Instructions contained in this document are not intended to cover all details or variations possible with Body-Solid equipment, or to cover every contingency that may be met in conjunction with installation, operation, maintenance or troubleshooting of the equipment. Even though we have prepared this manual with extreme care, neither the publisher nor the author can accept responsibility for any errors in, or omission from, the information given. Should additional information be required, or should situations arise that are not covered by this manual, the matter should be directed to your local Body-Solid representative, or the Service Department at Body-Solid Inc. in Forest Park, Illinois.

Any Questions?
Call (800) 556-3113

Dimensions

The room layout diagram below will help you decide the best placement for your GLPH1100.

The dimensions of the GLPH1100 are: Width 2' 11" X Length 7' 8".

The ceiling height requirement for the GLPH1100 is 4' 7".

The usage space is: Width 5' X Length 10' (The usage space is the overall space needed for operation).

The usage space needed for the GLPH1100 could be more, depending on the user.

Minimum Usage Space

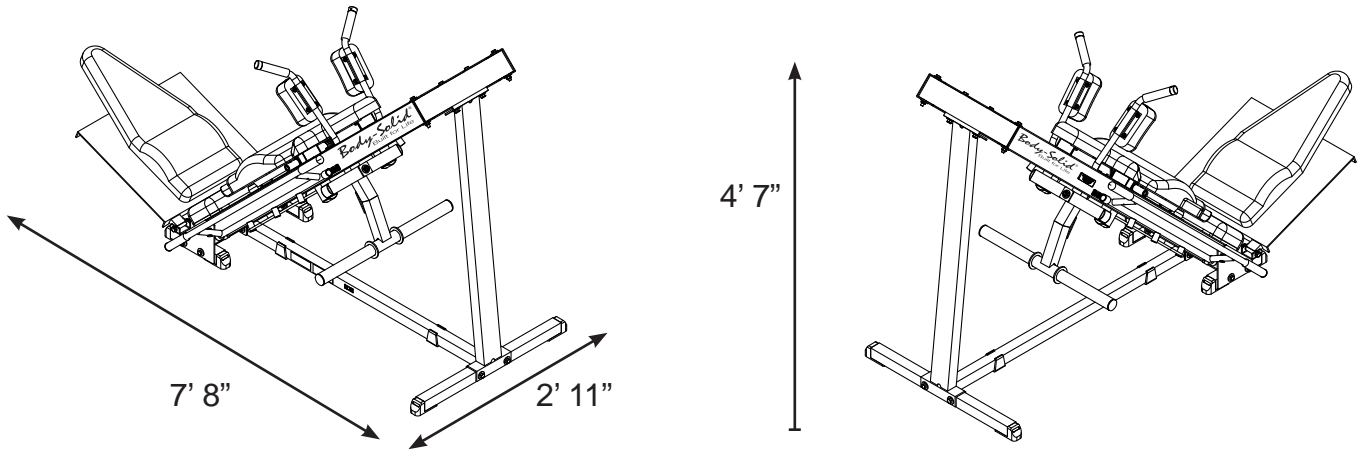

Suggested Usage Space

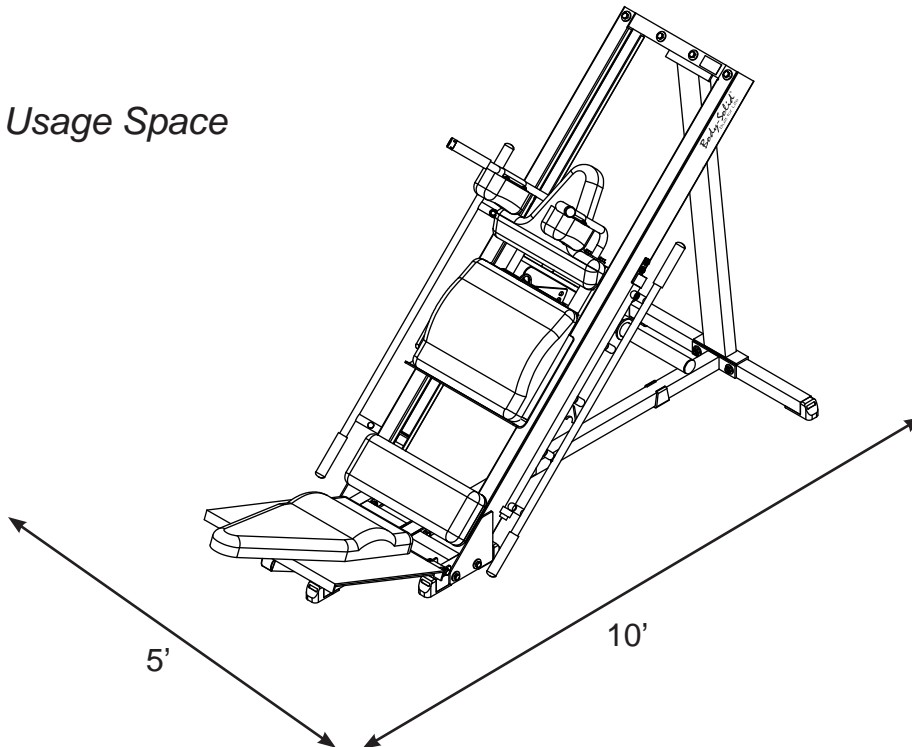

Safety Guidelines

Successful resistance training programs have one prominent feature in common... safety. Resistance training has some inherent dangers, as do all physical activities. The chance of injury can be greatly reduced or completely removed by using correct lifting techniques, proper breathing, maintaining equipment in good working condition, and by wearing the appropriate clothing.

- **It is highly recommended that you consult your physician before beginning any exercise program. This is especially important for individuals over the age of 35, or persons with pre-existing health problems.**
- **Always warm up before starting a workout. Try to do a total body warm up before you start. It is especially important to warm up the specific muscle groups you are going to be using. This can be as simple as performing a warm up set of high repetitions and light weight for each exercise.**
- **Use proper form. Focus on only working the muscle groups intended for the exercise you are doing. If there is strain elsewhere, you may need to re-evaluate the amount of weight that is involved with the lift. Keeping proper form also includes maintaining control through an entire range of motion.**
- **Breathe properly. Inhale during the eccentric phase of the exercise, and exhale during the lifting, or concentric phase. Never hold your breath during any part of an exercise.**
- **Always wear the appropriate clothing and shoes when exercising. Wearing comfortable athletic shoes with good support and loose fitting, breathable clothing will reduce the risk of injury.**
- **Maintaining equipment in proper operating condition is of utmost importance for a safe resistance training program. Pulleys and cables should be checked for wear frequently and replaced as needed. Equipment should be lubricated as indicated by the manufacturer.**
- **Read and study all warning labels on this machine. It is absolutely necessary that you familiarize yourself and all others with the proper operation of this machine prior to use.**
- **Keep hands, limbs, loose clothing and long hair well out of the way of all moving parts.**
- **Do not attempt to lift more weight than you can control safely.**
- **Inspect the machine daily for loose or worn parts. If a problem is found do not allow the machine to be used until all parts are tightened or worn or defective parts are repaired or replaced.**

Preparations

CAUTION: To set up this unit, you will need assistance.
Do not attempt assembly by yourself.

You must review and follow the instructions in this Owner's Manual. If you do not assemble and use the GLPH1100 according to these guidelines, you could void the Body-Solid warranty.

Required Tools

The basic tools that you must obtain before assembling the GLPH1100 include but are not limited to:

- Metric Allen Key Set
- Standard Allen Key Set
- Standard Wrench Set
- Metric Wrench Set
- Adjustable Wrench
- Screwdriver (standard and/or phillips)
- Rubber Mallet
- Silicone Spray Oil

CAUTION: Obtain assistance! Do not attempt to assemble the GLPH1100 by yourself. Review the Installation Requirements before proceeding with the following steps.

The GLPH1100 unit comes in five boxes. Be careful to assemble components in the sequence presented in this guide.

NOTE: With so many assembled parts, proper alignment and adjustment is critical. While tightening the nuts and bolts, be sure to leave room for adjustments.

Installation Requirements

Follow these installation requirements when assembling the GLPH1100:

Set up the GLPH1100 on a solid, flat surface. A smooth, flat surface under the machine helps keep it level. A level machine has fewer malfunctions.

Provide ample space around the machine. Open space around the machine allows for easier access.

Insert all bolts in the same direction. For aesthetic purposes, insert all bolts in the same direction unless specified (in text or illustrations) to do otherwise.

Leave room for adjustments. Tighten fasteners such as bolts, nuts, and screws so the unit is stable, but leave room for adjustments. Do not fully tighten fasteners until instructed in the assembly steps to do so.

Fill out and mail the warranty card.

Assembly Instructions

Assembly of the GLPH1100 takes professional installers about 2 hours to complete. If this is the first time you have assembled this type of equipment, plan on significantly more time.

Professional installers are highly recommended!

However, if you acquire the appropriate tools, obtain assistance, and follow the assembly steps sequentially, the process will take time, but is fairly easy.

Assembly Tips

Read all "Notes" on each page before beginning each step.

While you may be able to assemble the GLPH1100 using the illustrations only, important safety notes and other tips are included in the text.

Some pieces may have extra holes that you will not use. Use only those holes indicated in the instructions and illustrations.

IMPORTANT!

Before you begin you should look at the quick reference guide that shows all hardware parts (in actual size) along with the corresponding key numbers on the assembly instructions.

NOTE: To find out the length of a particular bolt, measure its shank (the long, narrow part beneath the head). Refer to the following diagram:

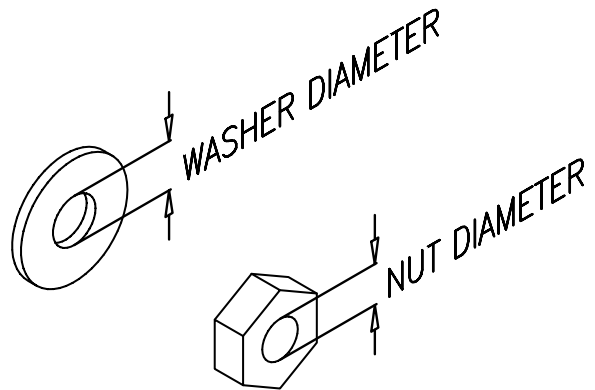
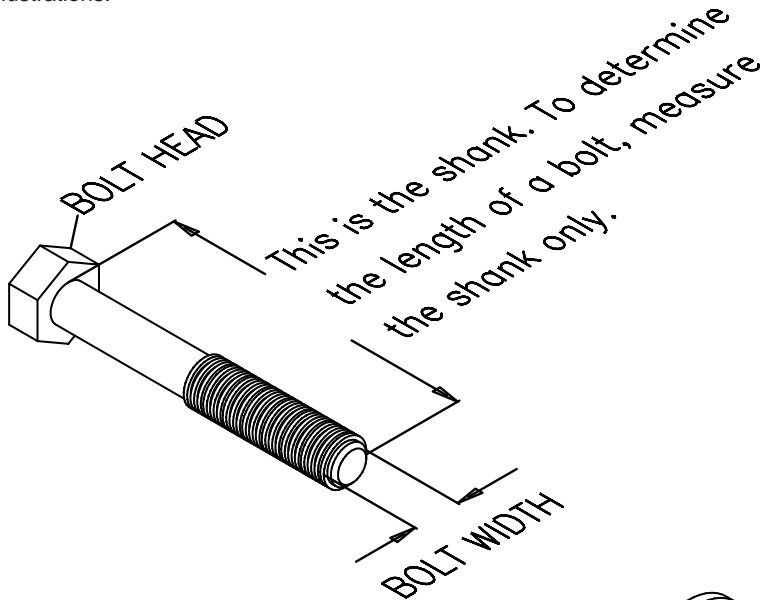

Do not fully tighten bolts until instructed to do so.

NOTE: After assembly, you should check all functions to ensure correct operation. If you experience **problems, first recheck the assembly instructions** to locate any possible errors made during assembly. If you are unable to correct the problem, call the dealer from whom you purchased the machine or call 1-800-556-3113 for the dealer nearest you.

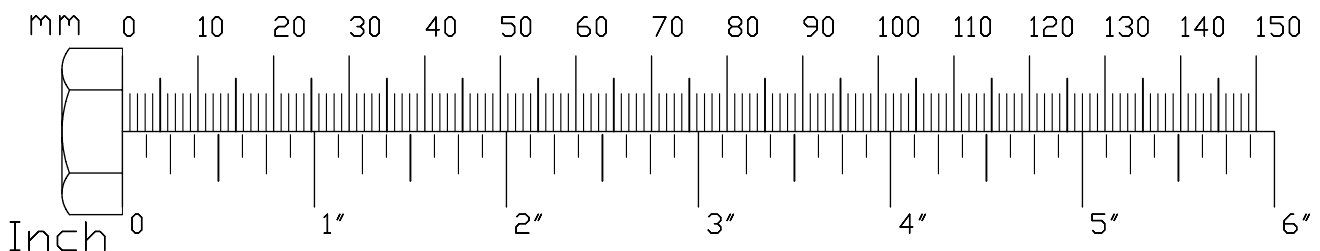

STEP

1

Be careful to assemble all components in the sequence they are presented.

NOTE: Tighten all hardware at the end of this step.

- A. Attach both Base Caps (34) to Base Frame (A) at the positions shown.
- B. Insert Foot Cap (32) into Base Frame (A).
- C. Insert two Foot Caps (32) into Left Stabilizer Frame (D).
- D. Insert two Foot Caps (32) into Right Stabilizer Frame (C).
- E. Insert two End Caps (28) into Selector Insert Frame (N).
- F. Make sure Pop-Pin (17) is preinstalled into Selector Tube (O).
- G. Set Selector Insert Frame (N) into Selector Tube (O) then secure Selector Tube (O) to Base Frame (A) using:
 - One 3 (M12x90 hex head bolt)
 - Two 21 (M12x25 washer)
 - One 18 (M12 nylon lock nut)
- H. Connect Right Stabilizer Frame (C) and Left Stabilizer Frame (D) to Base Frame (A) using:
 - Two 2 (M12x80 hex head bolt)
 - Four 22 (M12x34 washer)
 - Two 18 (M12 nylon lock nut)

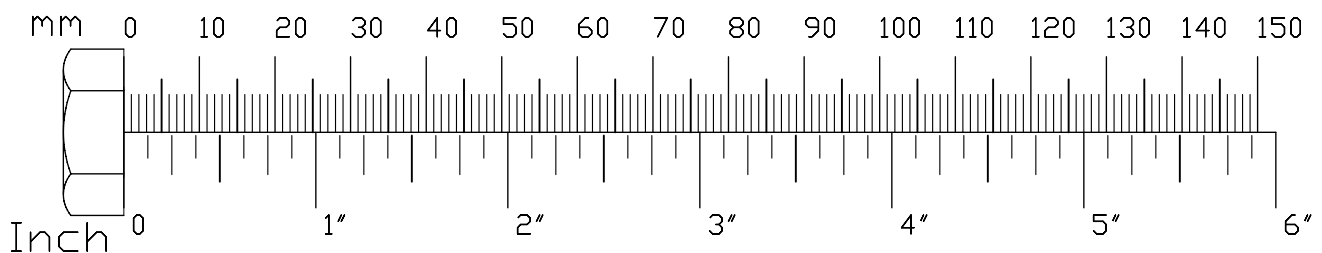

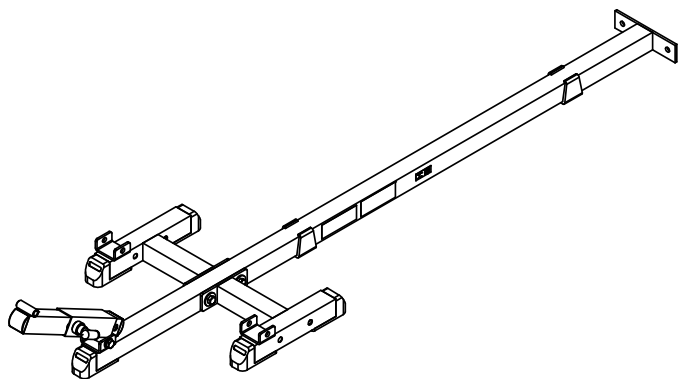

Above shows Step 1 assembled and completed.

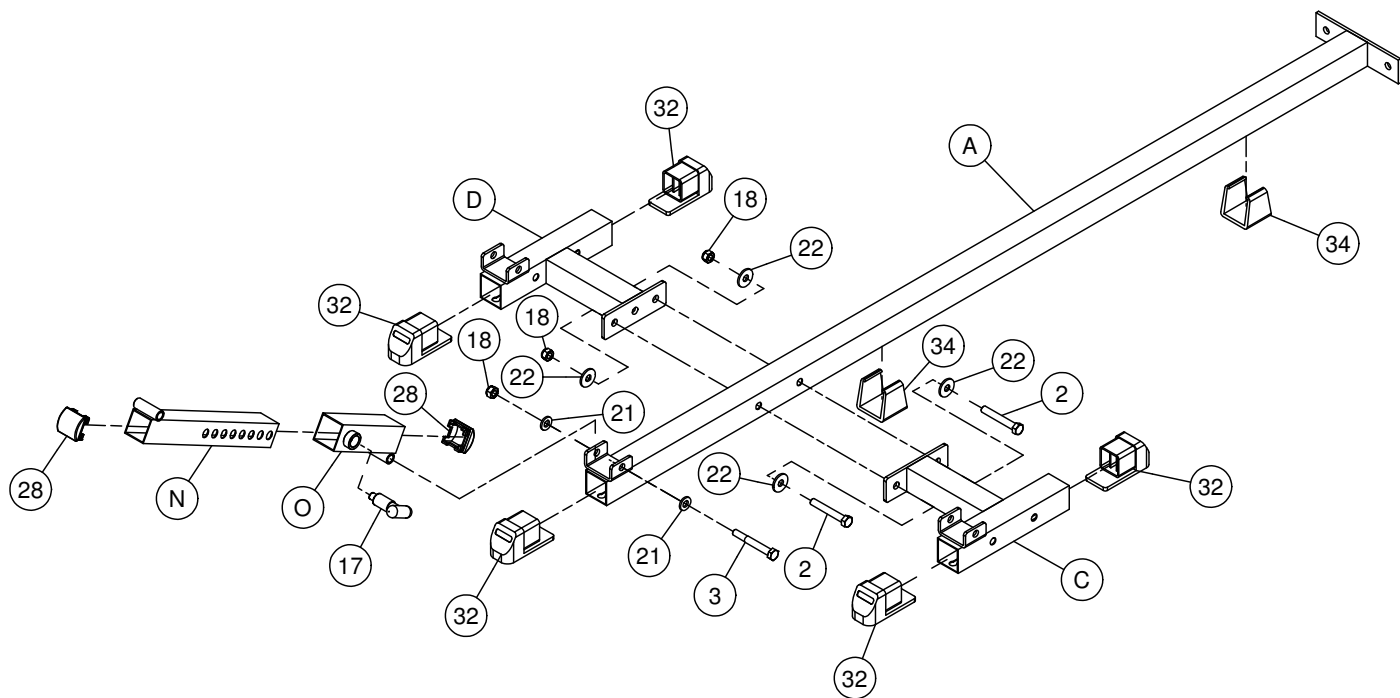

STEP**2**

Be careful to assemble all components in the sequence they are presented.

NOTE: Tighten all hardware at the end of this step.
Some components may be pre-installed.

- A. Insert two End Caps (39) into Carriage (H).
- B. Insert four End Caps (38) into Carriage (H).
- C. Insert two End Caps (29) into Carriage (H).
- D. Insert four End Caps (30) into Carriage (H).
- E. Unscrew both Allen Screws (13) from Carriage (H) to loosen Shaft (48).
- F. Slide Shaft (48) out of Carriage (H).
- G. Connect Adjustable Plate (K) to Carriage (H) by using:
 - Two 41 (copper spacer)
 - One 48 (shaft)
 - One 45 (torsional spring)
 - One 46 (torsional spring)

NOTE: Make sure Torsion Springs (45) and (46) are inserted as shown.

- H. Tighten both Allen Screws (13) in Carriage (H).

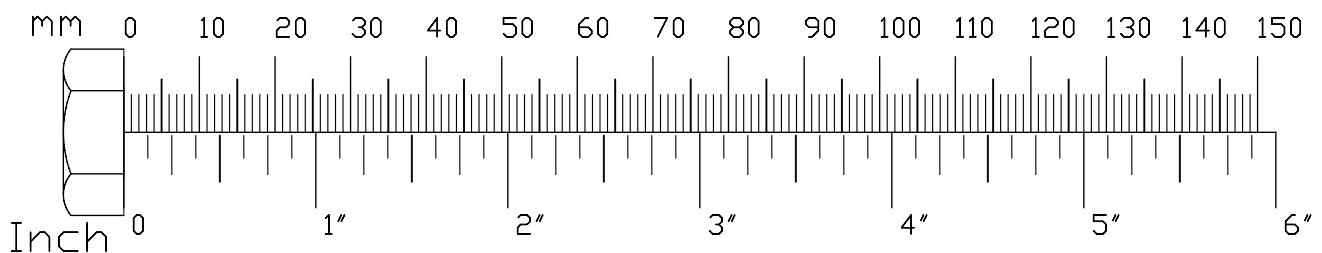

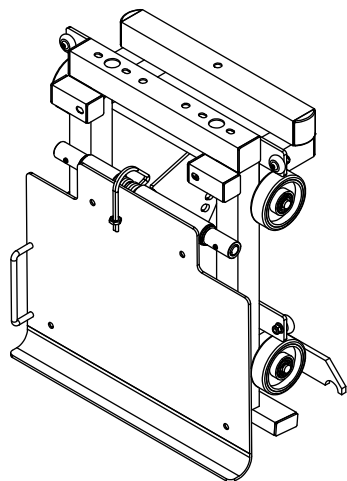

Above shows Step 2 assembled and completed.

Place the short side of both Torsion Springs into the square tube as shown.

Place the long side of both Torsion Springs into the pre-mounted hole located on the rear of Adjustable Plate (K).

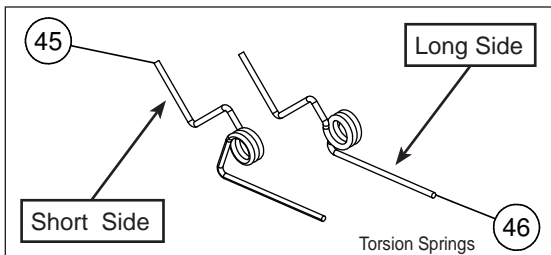
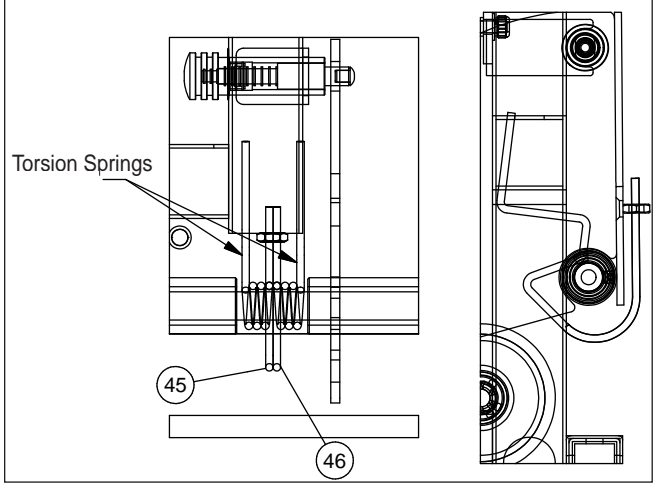
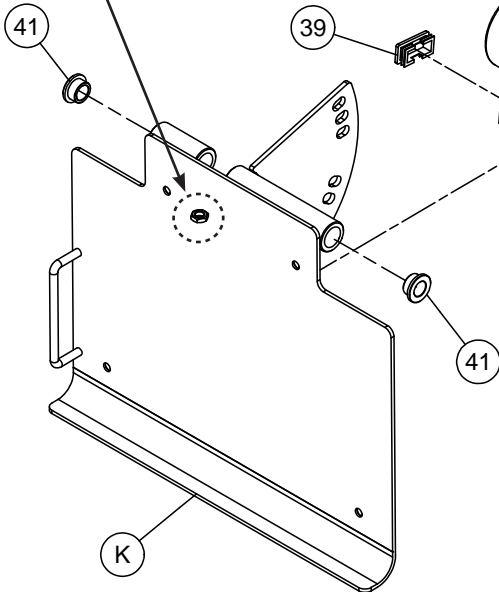
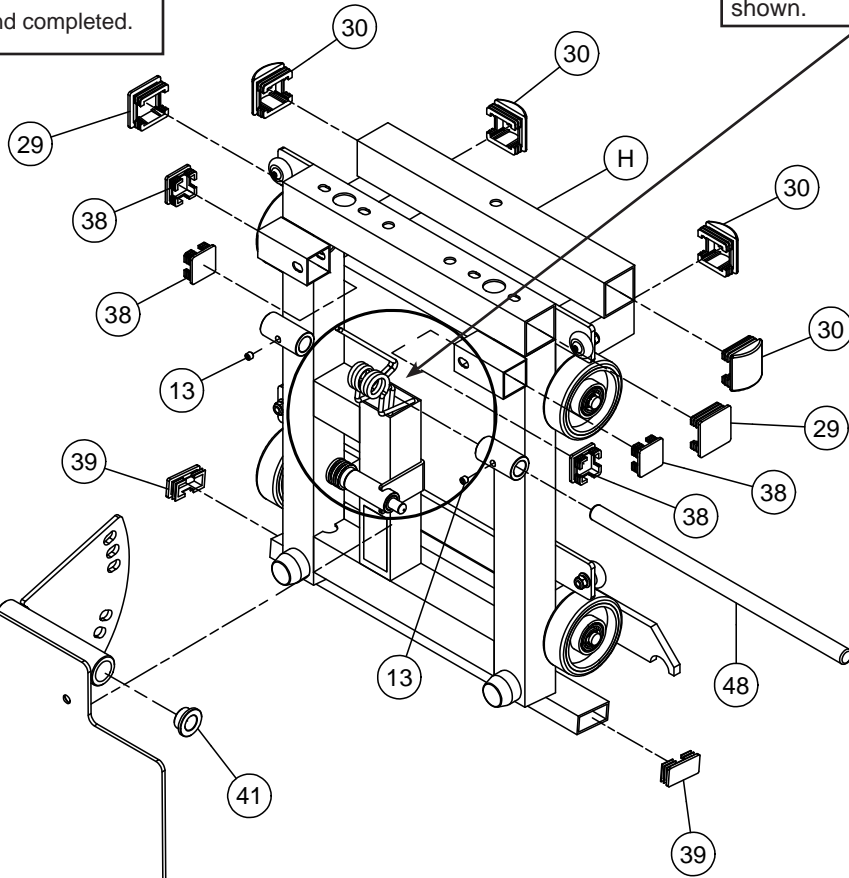

STEP**3**

Be careful to assemble all components in the sequence they are presented.

NOTE: Two people are required to assemble this section.
Tighten all hardware at the end of this step.

- A. **Connect Right Glide Frame (F) to Right Stabilizer Frame (C) using:**
Two 1 (M12x75 hex head bolt)
Four 22 (M12 washer)
Two 18 (M12 nylon lock nut)
- B. **Connect Left Glide Frame (G) to Left Stabilizer Frame (D) using:**
Two 1 (M12x75 hex head bolt)
Four 22 (M12 washer)
Two 18 (M12 nylon lock nut)
- C. **Attach Rubber Pads (35) into Left Glide Frame (G) and Right Glide Frame (F).**
NOTE: Secure Rubber Pads (35) as shown in the diagram.
- D. **Slide Carriage (H) into Left Glide Frame (G) and Right Glide Frame (F).**
NOTE: Carriage (H) is extremely heavy. Two people are required for this installation.
- E. **Insert two Foot Caps (32) into Base Cross Bar (E).**
- F. **Connect Upright (B) to Base Cross Bar (E) and Base Frame (A) using:**
Two 2 (M12x80 hex head bolt)
Four 22 (M12 washer)
Two 18 (M12 nylon lock nut)
- G. **Connect Cross Bar (AD) to Upright (B) using:**
Two 4 (M12x125 hex head bolt)
Four 22 (M12 washer)
Two 18 (M12 nylon lock nut)
- H. **Secure Left Glide Frame (G) and Right Glide Frame (F) to Cross Bar (AD) using:**
Two 5 (M12x135 hex head bolt)
Four 22 (M12 washer)
Two 18 (M12 nylon lock nut)

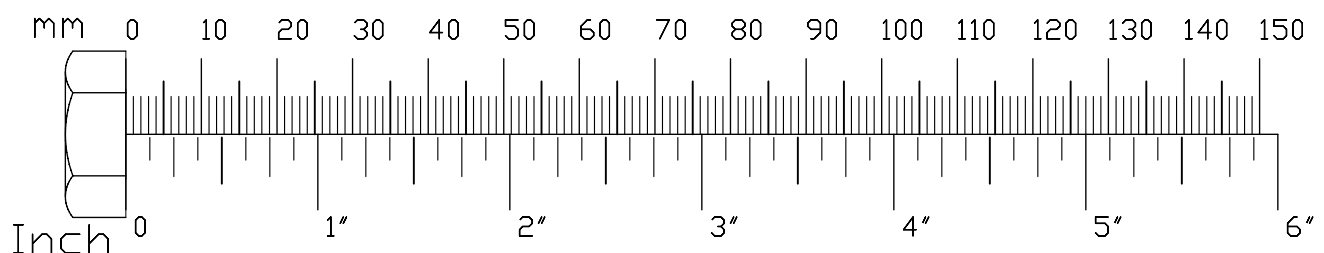

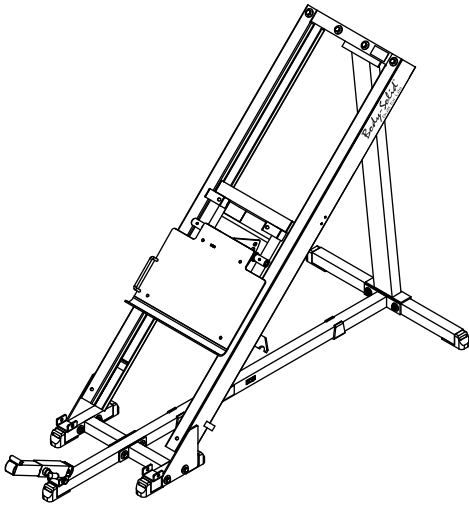

Above shows Step 3 assembled and completed.

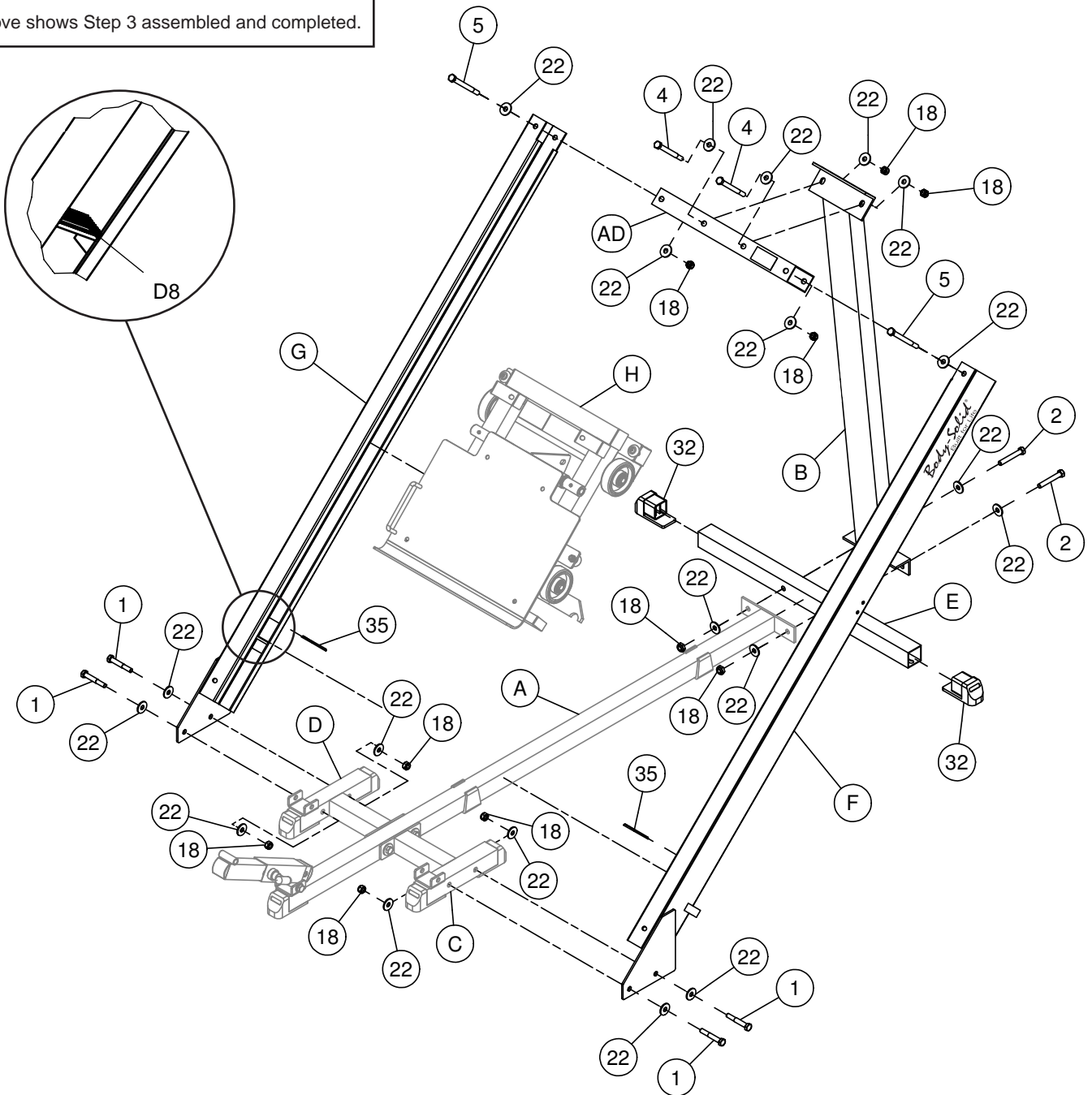

STEP**4**

Be careful to assemble all components in the sequence they are presented.

NOTE: Tighten all hardware at the end of this step.

- A. Connect Foot Plate (S) to Left Stabilizer Frame (D) and Right Stabilizer Frame (C) and secure using:
Two 3 (M12x90 hex head bolt)
Four 21 (M12x25 washer)
Two 18 (M12 nylon lock nut)
- B. Connect Foot Plate (S) to Selector Insert Frame (N) and secure using:
One 3 (M12x90 hex head bolt)
Two 21 (M12x25 washer)
One 18 (M12 nylon lock nut)
- C. Insert two Round End Caps (37) into the ends of Right Adjustment Bar (L) and two Round End Caps (37) to the ends of Left Adjustment Bar (M).
- D. Insert four Round End Caps (33) into Right Adjustment Bar (L) and four Round End Caps (33) into Left Adjustment Bar (M) as shown.
- E. Slide the short end of Right Adjustment Bar (L) into the round insert bracket on Right Glide Frame (F) as shown in the diagram.

NOTE: A detailed view of the long and short Adjustment Bar ends are shown in the figure on the next page.

- F. Insert the long end of Right Adjustment Bar (L) into Slide Tube (P) then secure Slide Tube (P) onto Right Glide Frame (F) using:
Two 8 (M8x20 hex head bolt)
Four 25 (M8 washer)
Two 20 (M8 nylon lock nut)
- G. Slide the short end of Left Adjustment Bar (M) into the round insert bracket on Left Glide Frame (G).

NOTE: A detailed view of the long and short Adjustment Bar ends are shown in the figure on the next page.

- H. Insert the long end of Left Adjustment Bar (M) into Slide Tube (P) then secure Slide Tube (P) onto Left Glide Frame (G) using:
Two 8 (M8x20 hex head bolt)
Four 25 (M8 washer)
Two 20 (M8 nylon lock nut)

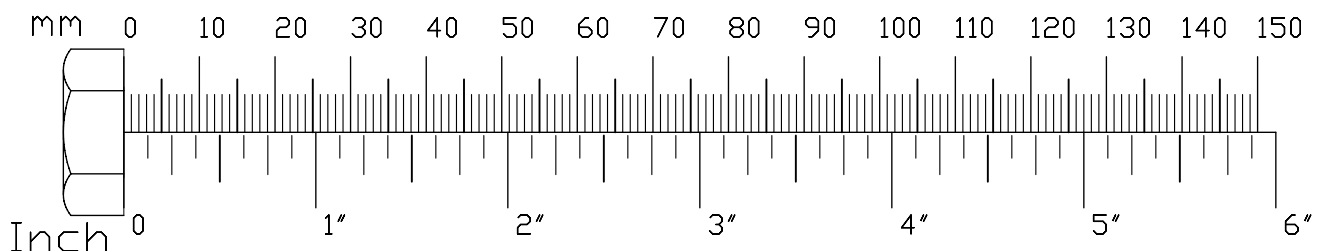

STEP**5**

Be careful to assemble all components in the sequence they are presented.

NOTE: Tighten all hardware at the end of this step.

- A. Connect Upper Pad (Y) to Adjustable Plate (K) using:
Four 9 ($\frac{5}{16}$ " x 1" allen pan head bolt)

NOTE: Do not over tighten Pad Bolts (9), over tightening will strip the T-nuts pressed into the wood.

- B. Attach Rubber Pad (36) to Lower Pad (AA).
NOTE: See figure on next page for a detailed view.

- C. Slide Left Lower Mount Frame (T) and Right Lower Mount Frame (U) onto the rod on Foot Plate (S) and secure Left Lower Mount Frame (T) and Right Lower Mount Frame (U) onto Lower Pad (AA) using:
Four 10 ($\frac{5}{16}$ " x 1" round allen head bolt)
Four 26 (M8 spring washer)
Four 25 (M8 washer)

NOTE: Do not over tighten Pad Bolts (10), over tightening will strip the T-nuts pressed into the wood.

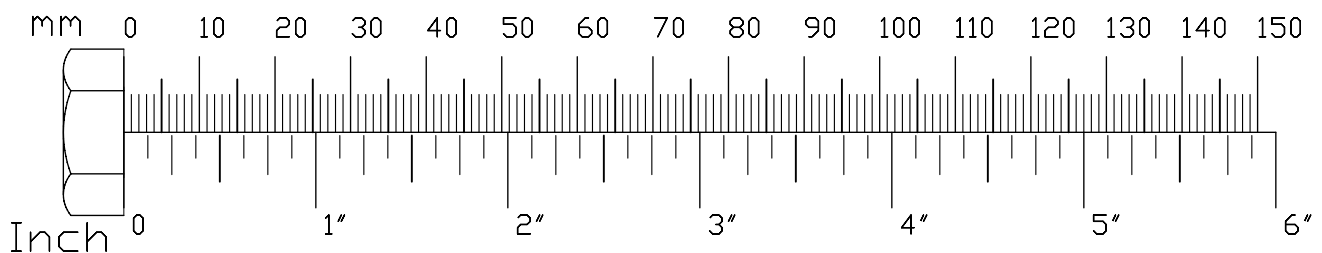

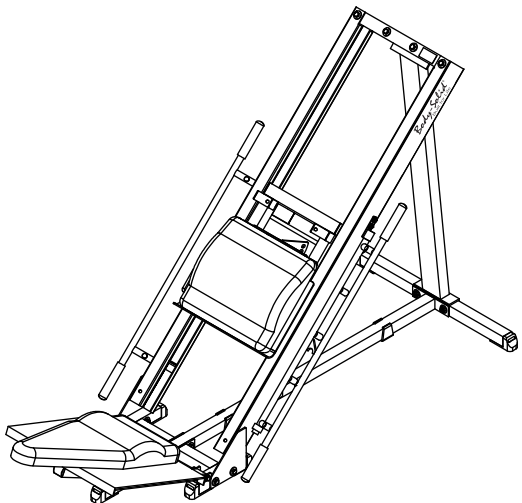

Above shows Step 5 assembled and completed.

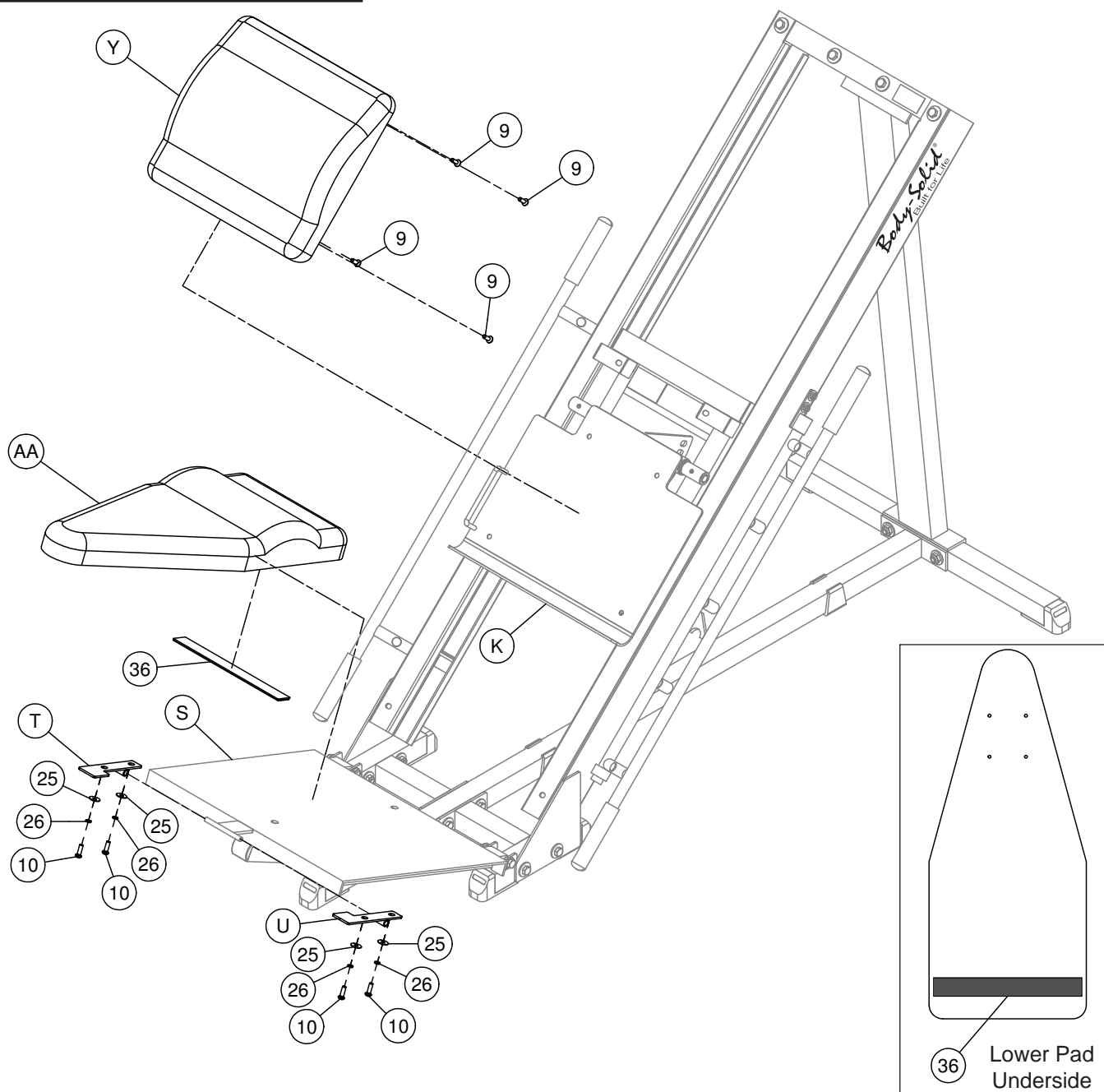

STEP**6**

Be careful to assemble all components in the sequence they are presented.

NOTE: Tighten all hardware at the end of this step.

- A. Connect Middle Pad (AC) to Right Glide Frame (F) and Left Glide Frame (G) using:
Two 11 ($\frac{9}{16}$ " x 1 $\frac{1}{4}$ " hex head bolt)
Two 26 (M8 spring washer)
Two 25 (M8 washer)

NOTE: See correct installation direction in diagram.

Do not over tighten Pad Bolts (11), over tightening will strip the T-nuts pressed into the wood.

- B. Connect Left Arm (Q) to Carriage (H) and secure using:
Two 7 (M10x75 hex head bolt)
Five 24 (M10 washer)
Two 19 (M10 nylon lock nut)
One 6 (M10x20) hex head bolt
- C. Connect Right Arm (R) to Carriage (H) and secure using:
Two 7 (M10x75 hex head bolt)
Five 24 (M10 washer)
Two 19 (M10 nylon lock nut)
One 6 (M10x20) hex head bolt

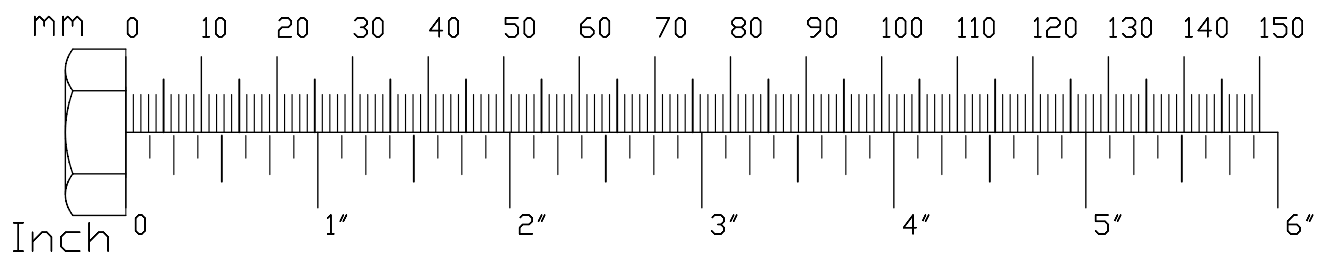

STEP**7**

Be careful to assemble all components in the sequence they are presented.

NOTE: Tighten all hardware at the end of this step.

- A. Insert End Cap (29) into Weight Horn Bar (J).
- B. Insert two Round End Caps (31) into Weight Horn Bar (J).
- C. Connect Weight Horn Bar (J) and Weight Horn Bar Support Plate (X) to Carriage (H) using:
Two 2 (M12x80 hex head bolt)
Four 22 (M12 washer)
Two 18 (M12 nylon lock nut)
- D. Secure Weight Horn Bar (J) to Carriage (H) by adding:
One 4 (M12x125 hex head bolt)
Two 22 (M12 washer)
One V (Support Plate)
One 18 (M12 nylon lock nut)
- E. Connect Arm Pad (AB) and Pad Frame (W) to Left Arm (Q) using:
Four 10 ($\frac{5}{16}$ " x 1" round allen head bolt)
Four 26 (M8 spring washer)
Four 27 (M8 washer)

NOTE: Do not over tighten Pad Bolts (10), over tightening will strip the T-nuts pressed into the wood.

- F. Connect Arm Pad (AB) and Pad Frame (W) to Right Arm (R) using:
Four 10 ($\frac{5}{16}$ " x 1" round allen head bolt)
Four 26 (M8 spring washer)
Four 27 (M8 washer)

NOTE: Do not over tighten Pad Bolts (10), over tightening will strip the T-nuts pressed into the wood.

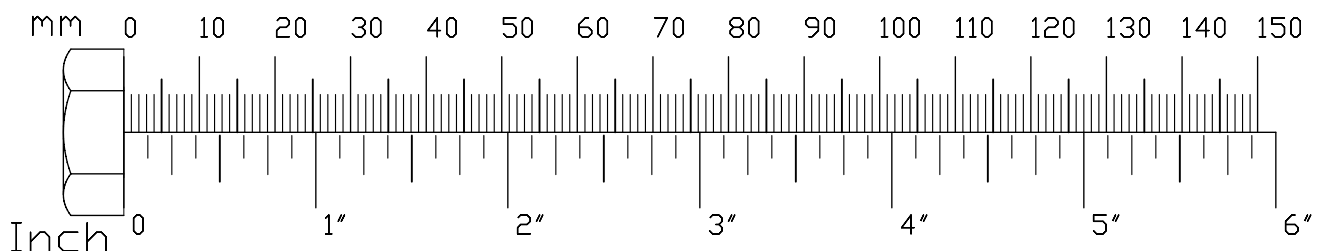

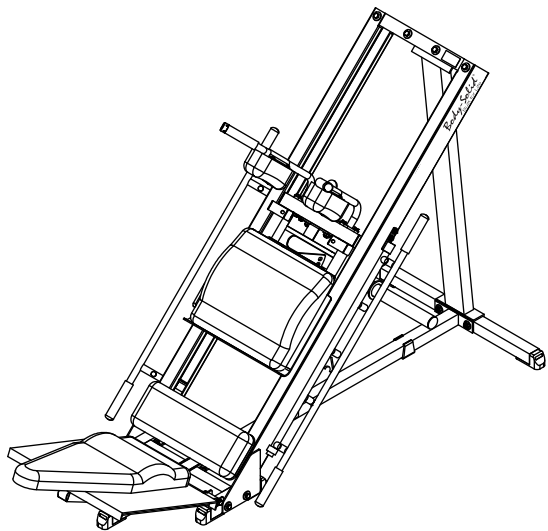

Above shows Step 7 assembled and completed.

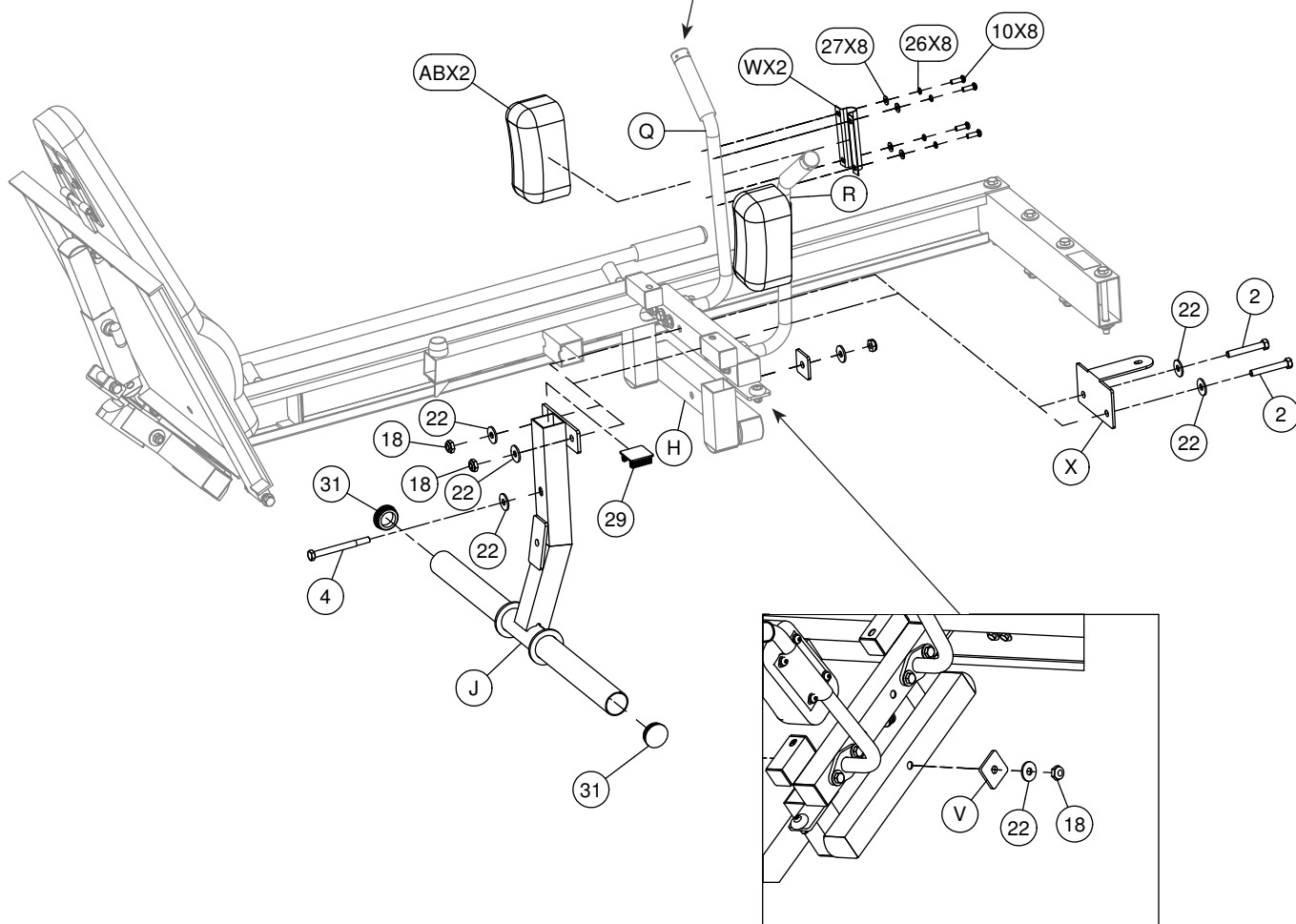
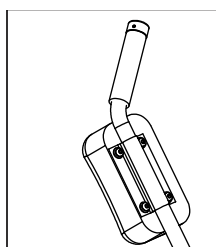

STEP

8

Be careful to assemble all components in the sequence they are presented.

NOTE: Tighten all hardware at the end of this step.

- A. Connect Head Rest Pad (Z) to Carriage (H) using:
Two 12 ($\frac{5}{16}$ " x 2 $\frac{1}{4}$ " hex head bolt)
Two 26 (M8 spring washer)
Two 25 (M8 washer)

NOTE: Do not over tighten Pad Bolts (12), over tightening will strip the T-nuts pressed into the wood.

- B. Connect Head Rest Pad (Z) to Weight Horn Bar Support Plate (X) using:
One 10 ($\frac{5}{16}$ " x 1" round allen head bolt)
One 26 (M8 spring washer)
One 25 (M8 washer)

NOTE: Do not over tighten Pad Bolt (10), over tightening will strip the T-nut pressed into the wood.

- C. Congratulations!! The assembly of your GLPH1100 is now complete.

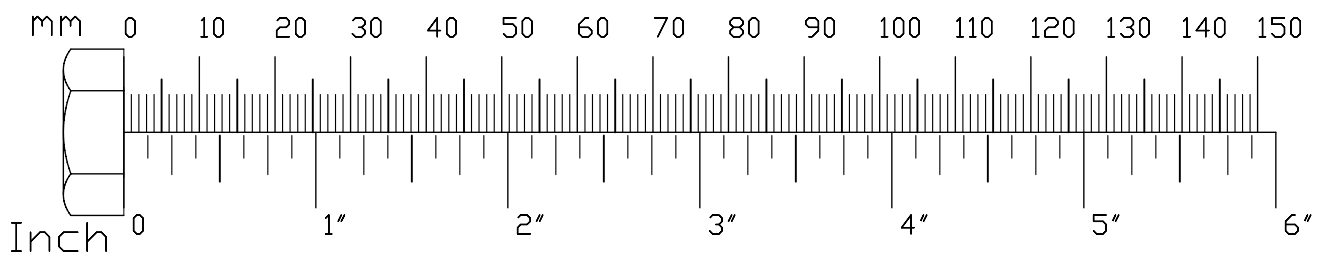

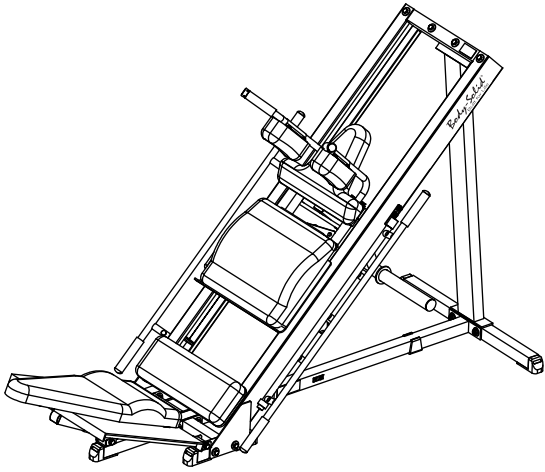

Above shows Step 8 assembled and completed.

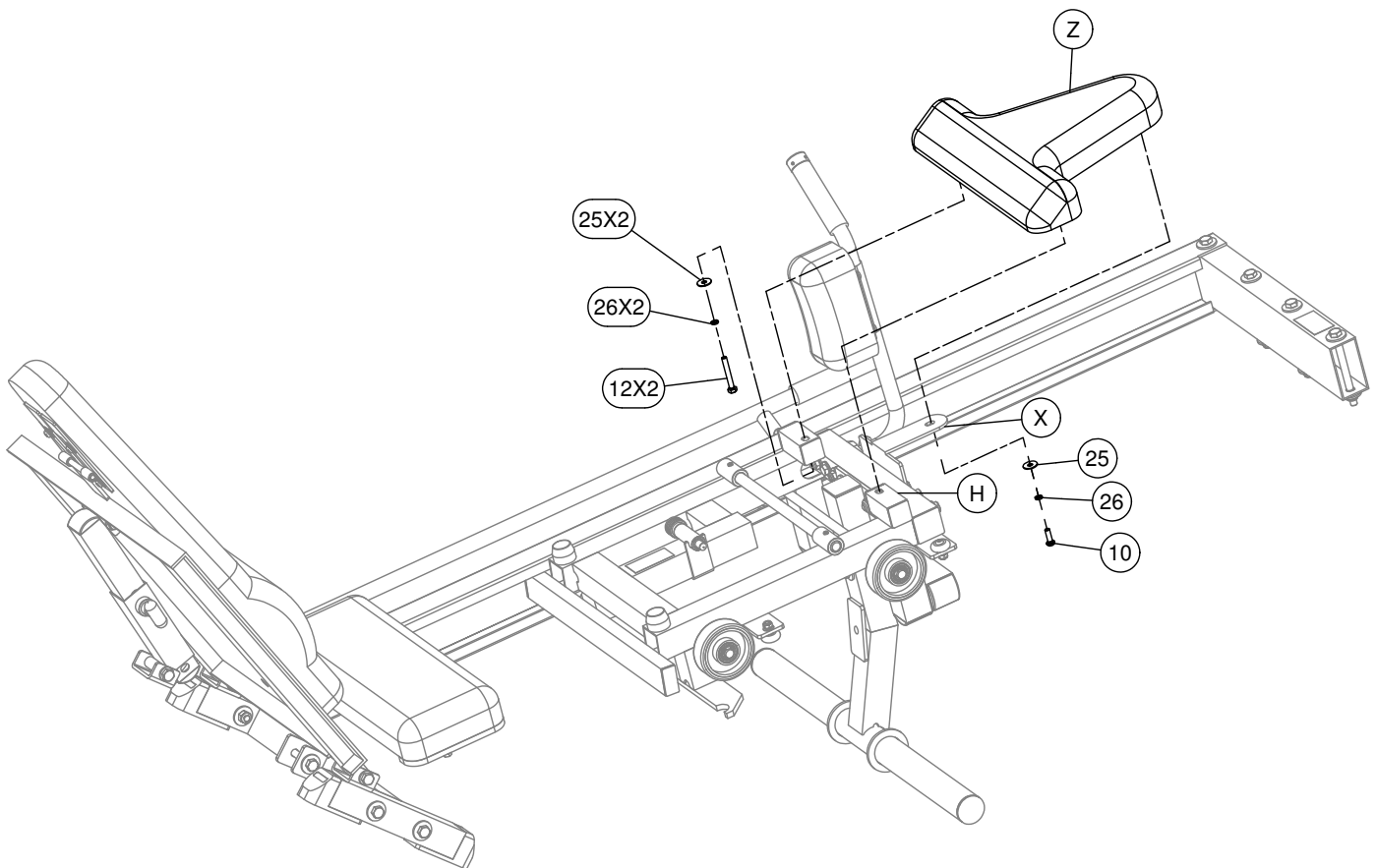

Warning, Safety & Maintenance

Precision craftsmanship assures Body-Solid's ability to consistently deliver products of the highest standards. Our products have been carefully designed to ensure safe, efficient long term operation.

However, it must be realized that safe use of this equipment requires that owners carefully read and follow the Body-Solid use recommendations, warnings, and maintenance guidelines in this Owners Manual.

Routine inspection and maintenance is of critical importance to ensure maximum safety and performance. Body-Solid uses the highest quality materials available, but wear is inevitable. Therefore, you must carefully inspect your equipment as outlined in the Maintenance Schedule.

Be advised that dangerous conditions can arise even during a warranty period. A warranty does not negate the owner's responsibility to thoroughly, carefully and daily inspect the machine.

Including maintaining the equipment, the owner's responsibility is also to:

- Be sure to always provide adequate supervision to all end-users.
- Be sure to instruct all end-users of proper usage.
- Be sure all supervisors and personal trainers who instruct end-users on equipment use are properly trained and know the function and importance of every adjustment and setting.
Also, be sure these trainers provide proper instruction to end-users on the fundamentals of strength training.

UPHOLSTERY:

- Wipe down after every workout.
- Periodically take the time to use a mild soap or a mild vinyl upholstery cleaner. Avoid using any abrasive cleaner not intended for use on vinyl.
- Keep sharp or pointed objects out of your pockets and clear of all upholstery.

NUTS/BOLTS/FASTENERS:

- Periodically inspect all nuts and bolts. Tighten if needed. If bolts seem to loosen periodically, use Loctite 242 for a long-term cure.
- Go through a re-tightening sequence periodically to ensure that all hardware is properly tensioned.

ADJUSTMENTS / LOCKING PINS / TIGHTENING KNOBS:

- Check all pieces for signs of visible wear or damage.
- Check springs in Snap Links and Pop Pins for proper tension and alignment.
- If the spring sticks or has lost its rigidity, replace it immediately.

ANTI-SKID SURFACES:

- Replace if they appear worn or become slippery.

WARNING INSTRUCTION LABELS:

- Inspect and familiarize yourself with all safety warnings and other user information on decals.

GLPH1100 Torsion Spring Removal

- **Remove the two Set Screws (13).**

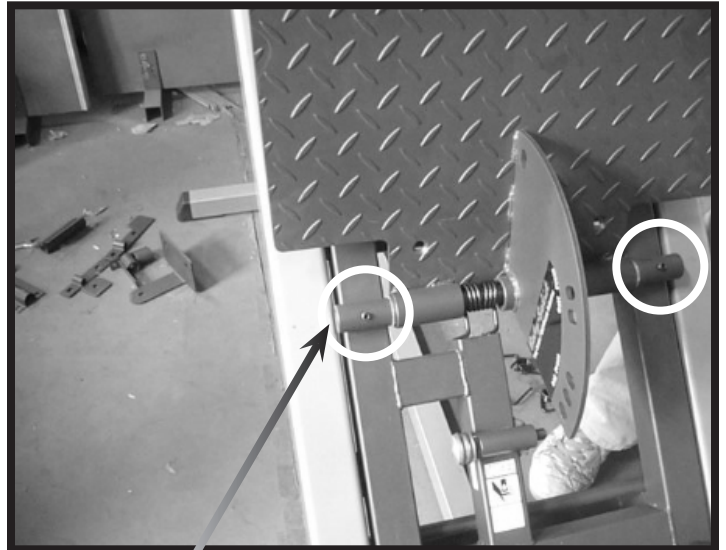

- **Remove the M12x135 Hex Head Bolt (5) as shown.**

or if Shaft (48) is not threaded as shown in the figure, *skip this step.*



- **Thread the M12x135 Hex Head Bolt (5) onto Shaft (48) and leave it finger tight.**

or if Shaft (48) is not threaded, then use a punch or other tool that can be used to push out Shaft (48).



GLPH1100 Torsion Spring Removal

- **Use a hammer to tap on the head of the threaded bolt or punch.**

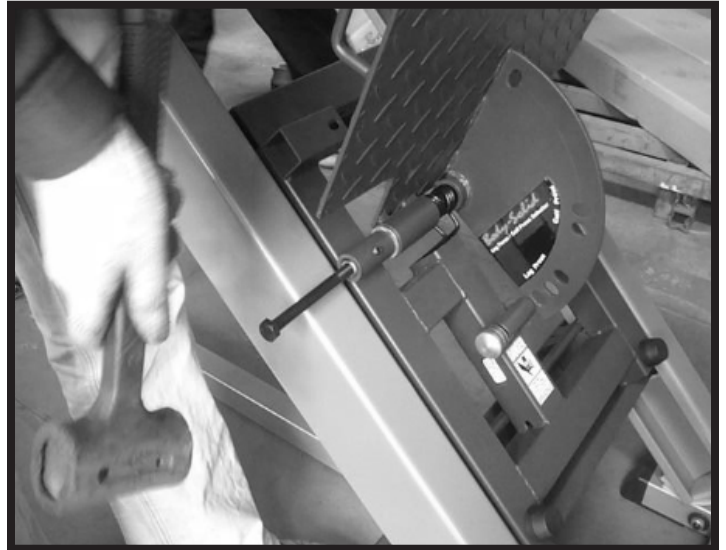

- **Continue using a hammer until the bolt or punch terminates near the axis opening or Shaft (48) is protruding out of the opposite end.**



- **Unscrew and remove the bolt, if this method has been used.**
- **Remember to reinstall the bolt back onto the GLPH1100 mainframe.**



GLPH1100 Torsion Spring Removal

- **Remove Shaft (48) by rotating and pulling it out of the axis of rotation.**
- **Lubrication may be required for this procedure.**



- **Carefully lift Adjustable Plate (K) away from the GLPH1100.**

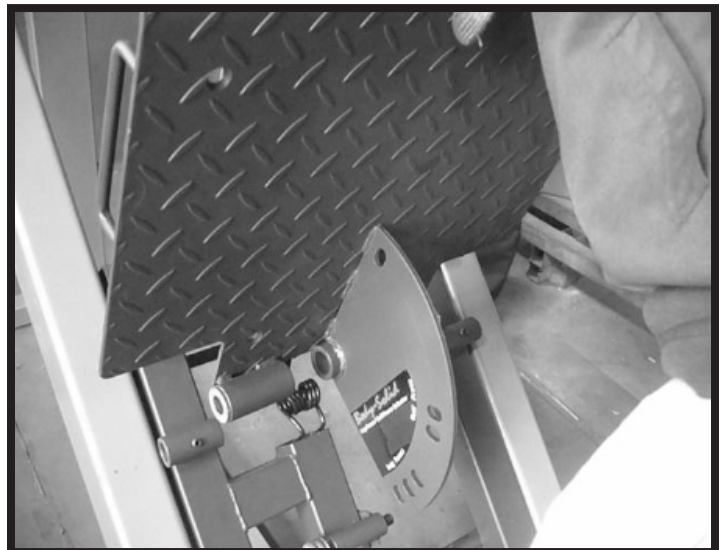

- **Remove both Torsion Springs (45) & (46).**



GLPH1100 Torsion Spring Installation

- **Insert the long side of Torsion Springs (45) & (46) into the rear hole of Adjustable Plate (K).**

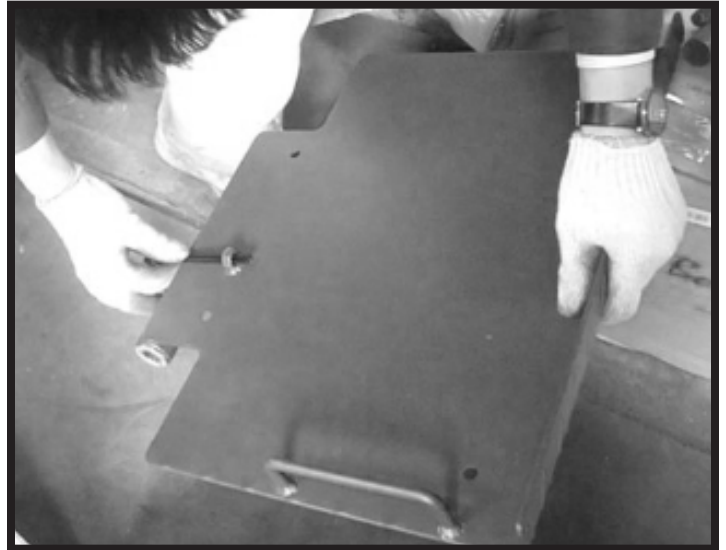

- **Insert the short side of the Torsion Springs (45) & (46) into the square frame on Carriage (H) as shown.**



- **Insert Shaft (48) into the first section of the axis.**
- **Lubrication may assist with this procedure.**

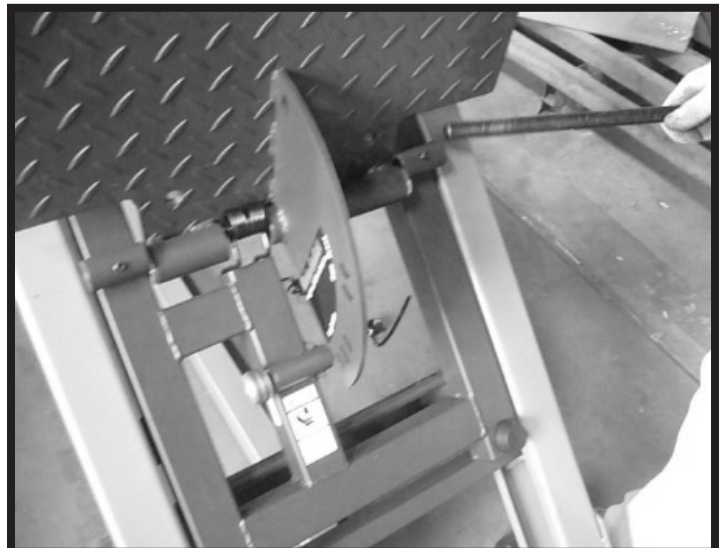

GLPH1100 Torsion Spring Installation

- **Push Shaft (48) inward making sure that both axis are aligned.**

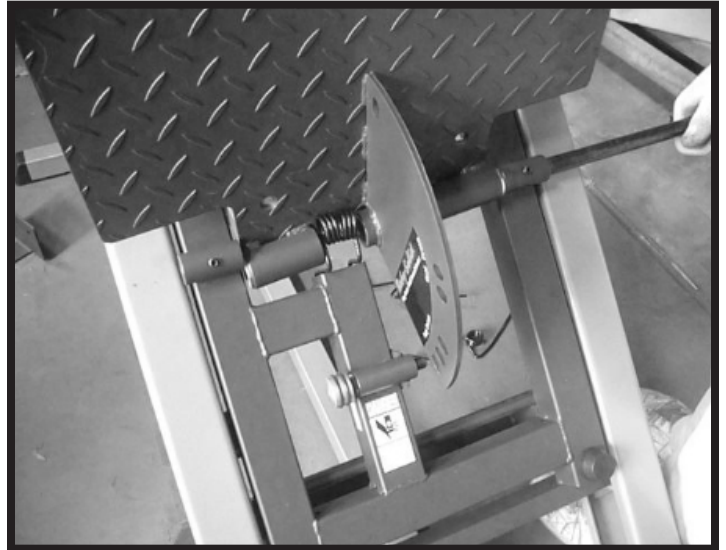

- **Torsion Springs (45) & (46) will need slight alignment while Shaft (48) is being inserted.**



- **Use a hammer to aid the process.**

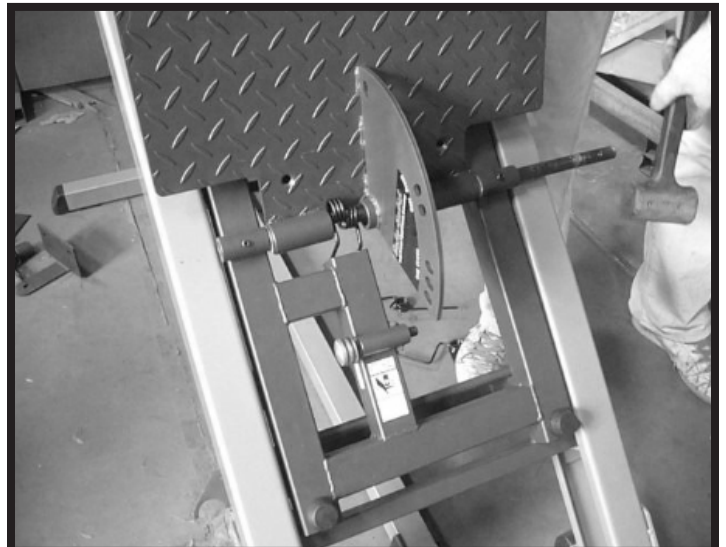

GLPH1100 Torsion Spring Installation

- **Once the shaft passes the first Torsion Spring, tap on the second Torsion Spring to bring it into alignment with the axis of rotation.**



- **Use a hammer to continue inserting Shaft (48).**

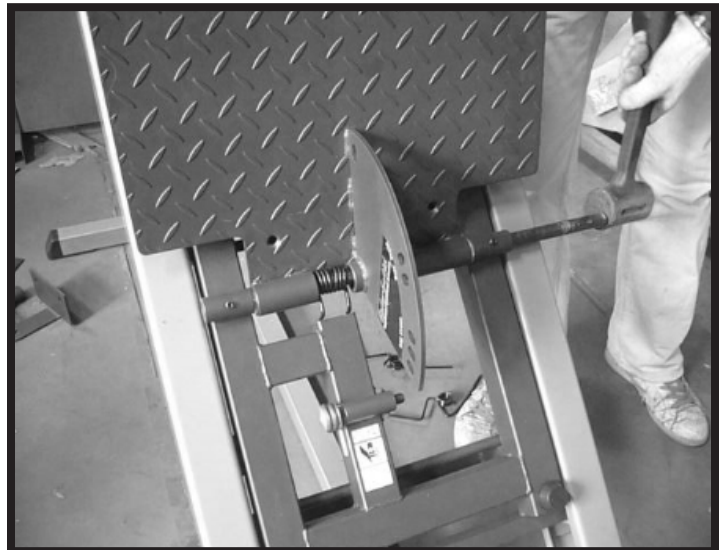

- **Make sure the remainder of Carriage (H) is aligned and continue to insert Shaft (48).**
- **Upon completion, tighten the two Set Screws (13) to secure Shaft (48).**



Mainframe Parts List

Part#	Qty	Description	
A	1	BASE FRAME	
B	1	UPRIGHT	
C	1	RIGHT STABILIZER FRAME	
D	1	LEFT STABILIZER FRAME	
E	1	BASE CROSS BAR	
F	1	RIGHT GLIDE FRAME	
G	1	LEFT GLIDE FRAME	
H	1	CARRIAGE	
J	1	WEIGHT HORN BAR	
K	1	ADJUSTABLE PLATE	
L	1	RIGHT ADJUST BAR	
M	1	LEFT ADJUST BAR	
N	1	SELECTOR INSERT FRAME	
O	1	SELECTOR TUBE	
P	2	SLIDE TUBE	
Q	1	LEFT ARM	
R	1	RIGHT ARM	
S	1	FOOT PLATE	
T	1	LEFT LOWER MOUNT FRAME	
U	1	RIGHT LOWER MOUNT FRAME	
V	1	SUPPORT PLATE	(8312-013)
W	2	PAD FRAME	(8343-023)
X	1	WEIGHT HORN BAR SUPPORT PLATE	(8333-045)
Y	1	UPPER PAD	(9112-026)
Z	1	HEAD REST PAD	(9132-016)
AA	1	LOWER PAD	(9112-025)
AB	2	ARM PAD	(9132-002)
AC	1	MIDDLE PAD	(9122-031)
AD	1	CROSS BAR	

Part numbers are required when ordering parts.

Hardware List (continued)

Part#	Qty	Description			
1	4	HEX HEAD BOLT	M12x75		
2	6	HEX HEAD BOLT	M12x80		
3	4	HEX HEAD BOLT	M12x90		
4	3	HEX HEAD BOLT	M12x125		
5	2	HEX HEAD BOLT	M12x135		
6	2	HEX HEAD BOLT	M10x20		
7	4	HEX HEAD BOLT	M10x75		
8	4	HEX HEAD BOLT	M8x20		
9	4	ALLEN PAN HEAD BOLT	5/16" x 1"		
10	13	ROUND ALLEN HEAD BOLT	5/16" x 1"		
11	2	HEX HEAD BOLT	5/16" x 1 1/4"		
12	2	HEX HEAD BOLT	5/16" x 2 1/4"		
13	2	ALLEN SCREW	M8X8		- PREINSTALLED
14	4	ROUND ALLEN HEAD BOLT	M8x30		- PREINSTALLED
15	4	ALLEN SCREW	M5x5		- PREINSTALLED
16	1	POP PIN	M31.5x115L	(8250-033)	- PREINSTALLED
17	1	POP PIN	M22x78L	(8250-033)	- PREINSTALLED
18	19	NYLON LOCK NUT	M12		
19	4	NYLON LOCK NUT	M10		
20	8	NYLON LOCK NUT	M8		
21	8	WASHER	M12 ID 25MM OD		
22	30	WASHER	M12 ID 34MM OD		
24	10	WASHER	M10 ID 27MM OD		
25	17	WASHER	M8 ID 24MM OD		
26	21	SPRING WASHER	M8		
27	12	WASHER	M8 ID 18MM OD		
28	2	END CAP	M45x45	(9211-091)	
29	3	END CAP	2" x 2"	(9211-006)	
30	4	END CAP	2" x 2"	(9211-087)	
31	2	ROUND END CAP	Ø50	(9211-020)	
32	7	FOOT CAP	2" x 2"	(9211-024)	
33	8	ROUND END CAP	Ø20	(9211-036)	
34	2	BASE CAP	2" x 2"	(9212-010)	
35	2	RUBBER PAD	M38x75	(9310-002)	
36	1	RUBBER PAD	M38x325	(9310-042)	
37	4	ROUND END CAP	1" x 2.5T	(9260-021)	
38	4	END CAP	M38x38	(9211-003)	
39	2	END CAP	M25x50	(9211-009)	
40	8	BEARING		(8510-002)	- PREINSTALLED
41	2	COPPER SPACER		(8520-013)	
42	4	CONVEXITY LOOP		(9213-018)	- PREINSTALLED
43	2	CHROME COLLAR	Ø35xØ26X19L	(8890-061)	- PREINSTALLED
44	2	FOAM GRIP		(9162-010)	- PREINSTALLED
45	1	TORSION SPRING		(8840-044)	- PREINSTALLED
46	1	TORSION SPRING		(8840-045)	- PREINSTALLED
47	2	BAFFLE WALL		(9310-018)	- PREINSTALLED
48	1	SHAFT	Ø3/4" x 410L	(8210-044)	- PREINSTALLED
49	8	C-CLIP			
50	2	BODY SOLID LOGO		(9440-028)	- PREINSTALLED
51	1	BODY SOLID PLATE		(9440-199)	- PREINSTALLED
52	2	POP PIN STICKER		(9440-104)	- PREINSTALLED
53	1	MAINTENANCE LABEL		(9440-103)	- PREINSTALLED
54	1	GENERAL WARNING STICKER		(9440-217)	- PREINSTALLED
55	1	SELECTOR STICKER		(9440-066)	- PREINSTALLED
56	1	CAUTION STICKER		(9440-220)	- PREINSTALLED
57	1	WEIGHT HORN WARNING STICKER		(9440-217)	- PREINSTALLED
58	1	PLATE DANGER STICKER		(9440-208)	- PREINSTALLED
59	4	FOAM GRIP		(9162-002)	- PREINSTALLED
60	4	PU WHEEL		(9213-044)	- PREINSTALLED

Part numbers are required when ordering parts.



Hardware (To Scale)

Part# 1 M12x75 Hex Head Bolt (Partial Thread) Qty. 4

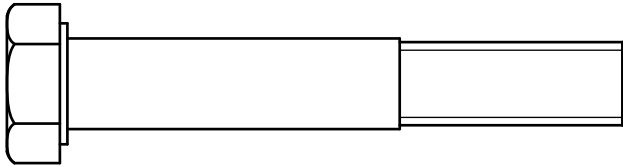

Part# 2 M12x80 Hex Head Bolt (Partial Thread) Qty. 6

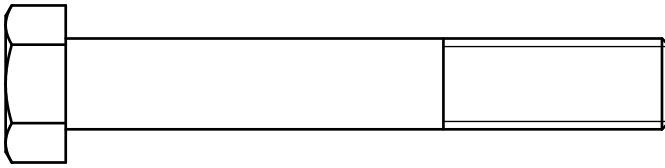

Part# 3 M12x90 Hex Head Bolt (Partial Thread) Qty. 4

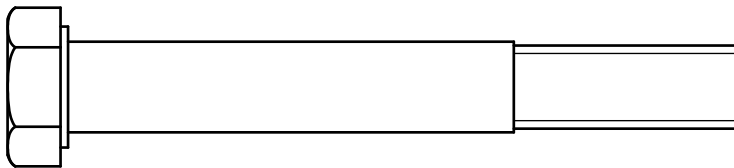

Part# 4 M12x125 Hex Head Bolt (Partial Thread) Qty. 3

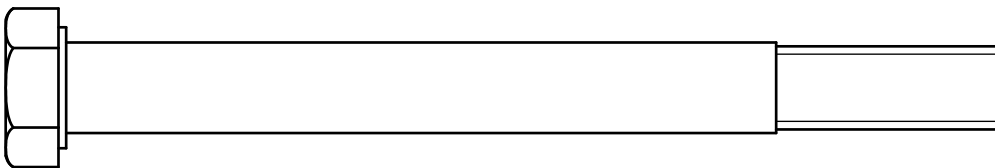

Part# 5 M12x135 Hex Head Bolt (Partial Thread) Qty. 2

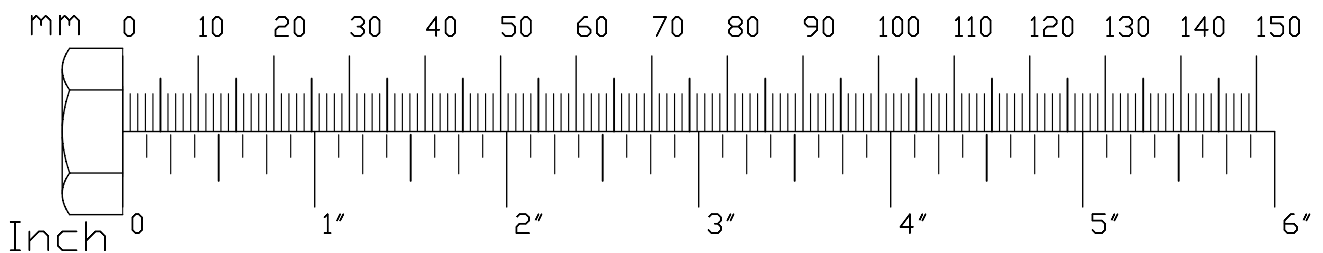
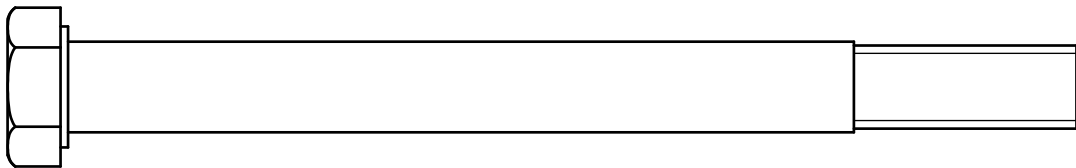

Hardware (To Scale)

Part# 6 M10x20 Hex Head Bolt (Partial Thread) Qty. 2

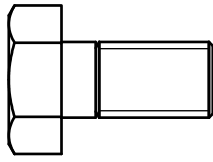

Part# 7 M10x75 Hex Head Bolt (Partial Thread) Qty. 4

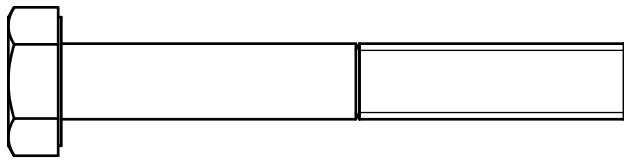

Part# 8 M8x20 Hex Head Bolt (Full Thread) Qty. 4

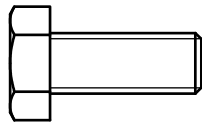

Part# 9 5/16" x 1" Pan Head Bolt (Full Thread) Qty. 4

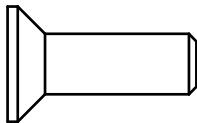

Part# 10 5/16" x 1" Round Allen Head Bolt (Partial Thread) Qty. 13

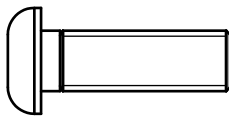

Part# 11 5/16" x 1 1/4" Hex Head Bolt (Full Thread) Qty. 2

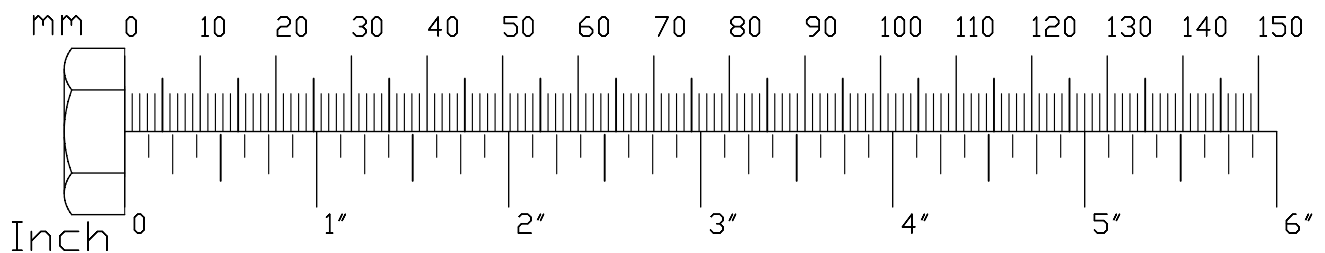
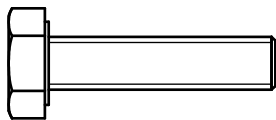

Hardware (To Scale)

Part# 12 $\frac{5}{16}$ " x 2 $\frac{1}{4}$ " Hex Head Bolt (Full Thread) Qty. 2

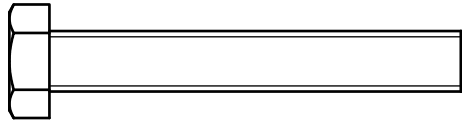

Part# 13 M8x8 Allen Screw (Full Thread) Qty. 2



Part# 14 M8x30 Round Allen Head Bolt (Partial Thread) Qty. 4

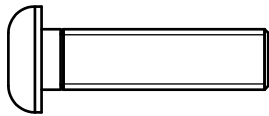

Part# 15 M5x5 Allen Screw (Full Thread) Qty. 4



Part# 18 M12 Nylon Lock Nut Qty. 19

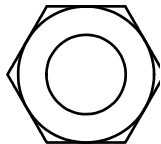
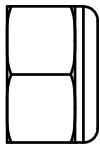

Part# 19 M10 Nylon Lock Nut Qty. 4

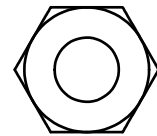
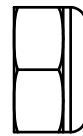

Part# 20 M8 Nylon Lock Nut Qty. 8

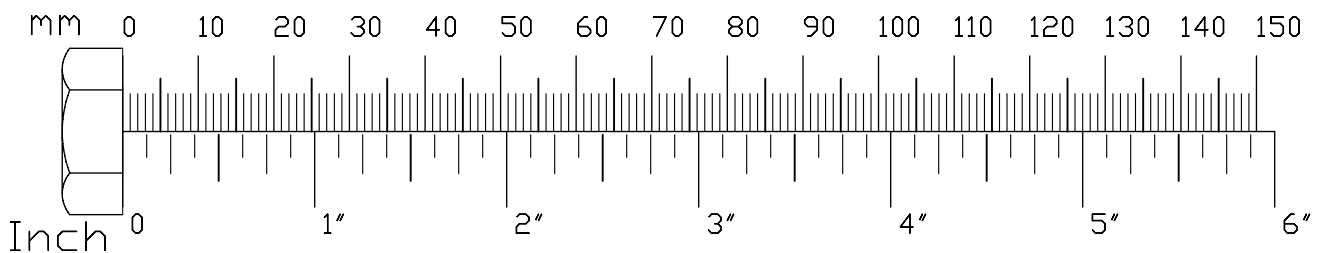
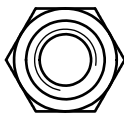
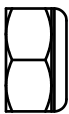

Hardware (To Scale)

Part# 21 M12 (Φ25) Washer Qty. 8

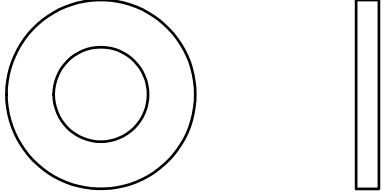

Part# 22 M12 (Φ34) Washer Qty. 30

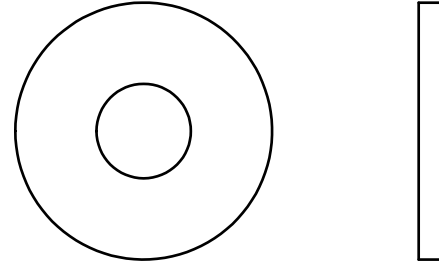

Part# 24 M10 (Φ27) Washer Qty. 10

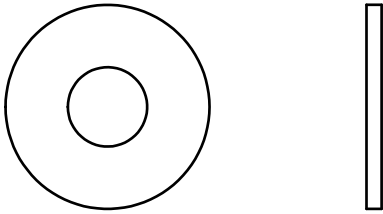

Part# 25 M8 (Φ24) Washer Qty. 17

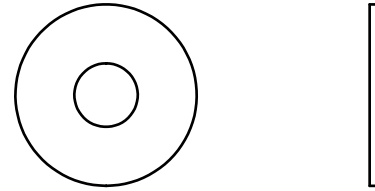

Part# 26 M8 Spring Washer Qty. 21



Part# 27 M8 (Φ18) Washer Qty. 12

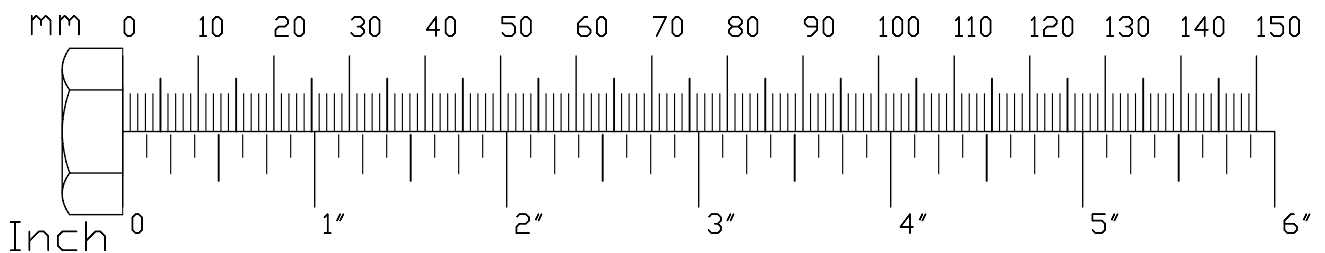
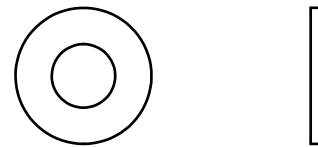

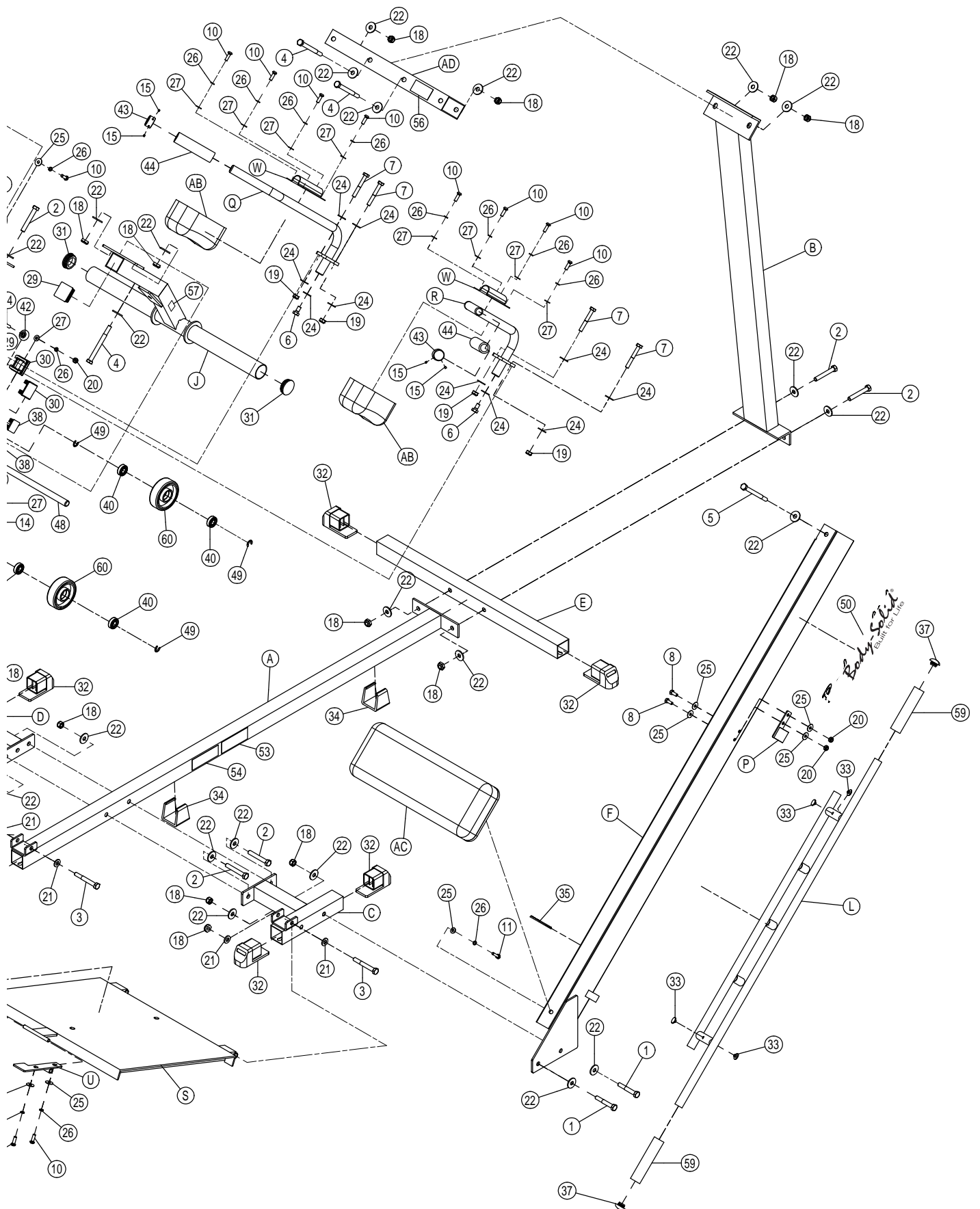

Body-Solid[®]
Built for Life

1900 S. Des Plaines Ave.
Forest Park, IL 60130
1 (800) 556-3113
Hours: M-F 8:30 - 5:00

www.bodysolid.com

© Copyright 2010. Body-Solid. All rights reserved. Body-Solid reserves the right to change design and specifications when we feel it will improve the product. Body-Solid machines maintain several patented and patent pending features and designs. All rights reserved on all design patents and utility patents.