

Sears

**operator's
manual**

- Assembly
- Operation
- Maintenance
- Repair Parts

MODEL NO.

358.356090-3.7/20"

358.356100-3.7/18" PS



WARNING:

Carefully read and follow Safety Rules, Precautions and Operating Instructions. Failure to do so can result in serious personal injury.



CRAFTSMAN

3.7/20" 3.7/18" PS

GASOLINE CHAIN SAWS

Record in the space provided below the Model No. and Serial No. of your saw. These numbers are located on the starting instructions decal.

Model No. _____ Serial No. _____

Retain these numbers for future reference.

Sears, Roebuck and Co., Chicago, Ill. 60684 U.S.A.

FULL ONE YEAR WARRANTY ON GASOLINE CHAIN SAW
(Excluding Bar, Chain, Spark Plug, Air Filter and Starter Rope)

For one year from date of purchase, when you maintain, lubricate, and tune up this chain saw according to the operating and maintenance instructions in the owner's manual, Sears will repair defects in material or workmanship in this gasoline chain saw at no charge.

This warranty excludes the bar, chain, spark plug, air filter, and starter rope which are expendable parts and become worn during normal use.

If this chain saw is used for commercial or rental purposes, this warranty applies for only 30 days from date of purchase. WARRANTY SERVICE IS AVAILABLE BY RETURNING THE CHAIN SAW TO THE NEAREST SEARS SERVICE CENTER IN THE UNITED STATES.

This warranty gives you specific legal rights, and you may also have other rights which vary from state to state.

Sears, Roebuck and Co., Sears Tower, Dept. 698/731A, Chicago, IL 60684

TABLE OF CONTENTS

Specifications	2	Using the Power Sharp® System	12
Safety Rules and Precautions	3	Types of Cutting	14
Know Your Chain Saw	5	A. Basic Cutting Technique	14
A. Introduction	5	B. Tree Felling Techniques	14
B. State and Local Ordinances	5	C. Bucking	16
C. Carton Contents	5	D. Debranching and Pruning	17
Preparing Your Saw For Use	6	Maintenance	18
A. Getting Ready	6	A. Guide Bar and Chain	18
B. Attaching the Handguard	6	B. Ignition, Cooling, and Exhaust Systems	19
C. Attaching the Spur	6	C. Starter Rope Repair and Replacement	20
D. Attaching the Bar and Chain	7	D. Clutch and Drum/Sprocket	21
E. Chain Tension	8	E. Carburetor Adjustments	22
F. Engine Fuel Mixture	8	F. Air Filter	23
G. Bar and Chain Oil	9	G. Counter-Vibe® Vibration System	23
Using Your Saw	10	H. Storage	24
A. Control Devices	10	I. Maintenance Accessories	24
B. Starting Instructions	10	J. Trouble Shooting Chart	25
C. Controlling Kickback	11	K. Maintenance Chart	26
		Parts List	28
		Quick Reference Page	35

SPECIFICATIONS

MODEL	358.356090 (3.7/20")	358.356100 (3.7/18" P.S.)
CU. IN. DISPLACEMENT	3.7 cu. in./60 cu. cm.	3.7 cu. in./60 cu. cm.
GUIDE BAR - LO-KICK®	20" Sprocket Nose	18" Sprocket Nose
CHAIN	3/8 Extended Pitch Oregon® Xtra-GUARD® Chrome Cutters - 70 Drive Links	3/8 Extended Pitch Oregon® Power Sharp® Chrome Cutters-66 Drive Links
SPARK PLUG	Champion CJ-8Y	
SPARK PLUG GAP	.023 to .027	
IGNITION	Solid State	
MODULE AIR GAP	.008 to .014	
FUEL MIX	Gasoline/Oil Mixture 16:1	
MUFFLER	Spark Arresting Temperature Limiting	
OILER SYSTEM	Automatic Manual	
FUEL TANK CAPACITY	19 oz. 562 cu. cm.	
OIL TANK CAPACITY	12 oz. 355 cu. cm.	

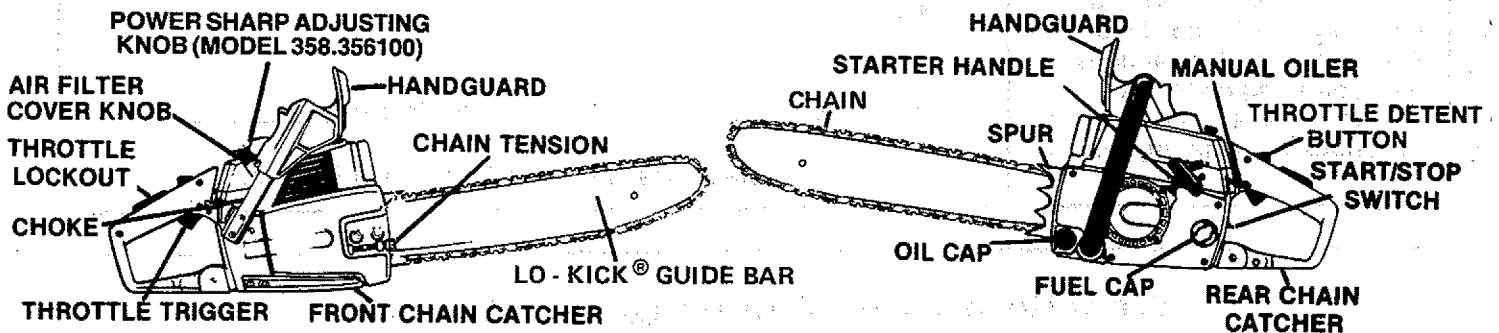

SAFETY RULES AND PRECAUTIONS

WARNING!

Because a chain saw is a high-speed wood-cutting tool, special safety precautions must be observed to reduce the risk of personal accidents. Careless or improper use may cause serious injury.

A. KNOW YOUR SAW

1. Read your Owner's Manual carefully until you completely understand and can follow all safety rules and operating instructions *before* attempting to operate the unit.
2. Restrict the use of your saw to adult users who understand and follow the safety rules, precautions, and operating instructions found in this manual.

B. PLAN AHEAD

1.  Wear personal protective gear. Always use steel-toed safety footwear with non-slip soles; snug-fitting clothing with reinforced cutting resistant inserts; heavy-duty non-slip gloves; appropriate eye protection such as non-fogging, vented goggles or face screen; an approved safety hard hat, and sound barriers — ear plugs or mufflers to protect your hearing. Regular users should have hearing checked regularly as chain saw noise may damage hearing.
2. **Keep children, bystanders, and pets out of the work area.** Do not allow other people to be near the chain saw when starting or operating the chain saw.
3. **Do not handle or operate a chain saw when you are fatigued, ill, or upset; or if you have taken alcohol, drugs or medication.** You must be in good physical condition and mentally alert. Chain saw work is strenuous. If you have any condition that might be aggravated by strenuous work, check with your doctor before operating a chain saw.
4. **Do not attempt to use your saw during bad weather conditions** such as strong wind, rain, snow, etc., or during darkness.
5. **Plan your sawing operations carefully in advance.** Do not start cutting until you have a clear work area, secure footing, and if you are felling trees, a planned retreat path.

C. GUARD AGAINST KICKBACK

Kickback can lead to dangerous loss of control of the saw and possibly cause serious personal injury. Kickback is the upward and backward motion of the guide bar that occurs when the moving chain contacts an object at the tip of the guide bar.

To reduce the hazard of kickback:

1. **Hold the saw firmly with both hands.** Left hand on front handle bar, right hand on rear handle *whether you are right-handed or left-handed.* Never use the saw with one hand.
 2. **Do not overreach.**
 3. **Do not let the tip of the guide bar contact the ground, another log, branch, or any other obstruction.**
 4. **Begin and continue cutting at full throttle.**
 5. **Cut one log at a time.**
 6. **Use extreme caution when re-entering a previous cut.**
 7. **Do not attempt plunge cuts.**
 8. **Watch for shifting logs or other forces that could close a cut and pinch the chain.**
 9. **Do not cut above shoulder height.**
 10. **Follow manufacturer's chain sharpening and maintenance instructions.** Keep the chain properly tensioned. Check tension at regular intervals with the engine stopped, never with the engine running. Make sure the bar clamp nuts are securely tightened after tensioning the chain.
11. **Use the Guard Link Chain and Lo-Kick® Guide Bar** designed for your saw to reduce the hazard of kickback.

D. AVOID REACTIVE FORCES

Pushback and Pull-in occur when the chain is suddenly stopped by being pinched, caught, or by contacting a foreign object in the wood. This results in a reversal of the chain force used to cut wood and causes the saw to move in the opposite direction of chain rotation, resulting in loss of control and possible serious personal injury.

To avoid Pushback:

1. **Be extremely aware of situations or obstructions** that may cause material to pinch the top of or otherwise stop the chain.
2. **Do not cut more than one log at a time.**
3. **Do not twist the saw** as the bar is withdrawn from an under-cut when bucking.

To avoid Pull-in:

1. **Always begin cutting with the engine at full throttle and the spike against the wood.**
2. **Use wedges made of plastic, wood, or light alloy (never of steel or iron)** to hold the cut open.

E. HANDLE FUEL WITH CAUTION

1. Eliminate all sources of sparks or flame in the areas where fuel is mixed, poured, or stored. There should be no smoking, open flames, or work that could cause sparks.
2. Mix, pour and store fuel in a well-ventilated area, on bare ground, and in an approved, marked container.
3. Wipe up all spilled fuel before starting your saw.
4. Move at least 10 feet (3 meters) away from fuel and fueling site before starting the engine.
5. Do not smoke while handling fuel or while operating the saw.
6. Turn the engine off and let your saw cool before removing the fuel tank cap and refueling the unit.
7. Let the saw cool in a non-combustible area, not on dry leaves, straw, paper, etc.

F. OPERATE YOUR SAW SAFELY

1. Do not operate a chain saw that is damaged, improperly adjusted, or not completely and securely assembled.
2. Do not operate the saw from a ladder or in a tree.
3. Position all parts of your body away to the side of the saw chain protruding to the left of cut when the engine is running.
4. Cut wood only. Do not use to pry or shove away limbs, roots or other objects.
5. Make sure the chain will not make contact before starting the engine. Never try to start the saw when the guide bar is in a cut or kerf.
6. Use extreme caution when cutting small size brush and saplings. Slender material may catch the saw chain and be whipped toward you or pull you off balance.
7. Be alert for springback when cutting a limb that is under tension so you will not be struck by the limb or saw when the tension in the wood fibers is released.
8. Do not put pressure on the saw at the end of a cut. This could cause you to lose control when the cut is completed.
9. Stop the engine before setting the saw down.

Exposure to vibrations through prolonged use of chain saws may produce Whitefinger disease (Raynaud's phenomenon). This phenomenon reduces the hand's ability to feel and regulate temperature, produces numbness and burning sensations and may cause nerve and circulation damage and tissue necrosis. An anti-vibration system designed to reduce engine vibration is available on many Sears models and is recommended for those using chain saws on a regular or sustained basis.

An anti-vibration system does not guarantee the avoidance of Whitefinger disease. Continual and regular users should monitor closely their use of chain saws and physical condition.

G. MAINTAIN YOUR SAW IN GOOD WORKING ORDER

1. Have all chain saw service performed by your authorized service dealer center, other than the items listed in the maintenance section of this manual.
2. Keep fuel and oil caps, screws and fasteners securely tightened.
3. Keep the handles dry, clean, and free of oil or fuel mixture.
4. Make certain the saw chain stops moving when the throttle trigger is released. If it does not, refer to page 22 for correct carburetor idle adjustment instructions.
5. Stop the saw if the chain strikes a foreign object. Inspect the unit and repair or replace parts as necessary.
6. Disconnect the spark plug before performing any maintenance except for carburetor adjustments.
7. Never modify your saw in any way. Use only attachments supplied or specifically recommended by Sears.

H. CARRY AND STORE YOUR SAW SAFELY

1. Hand carry the unit with the engine stopped, the Muffler away from your body, and the Guide Bar and Chain to the rear covered preferably with a scabbard.
2. Before transporting in any vehicle or storing in any enclosure, allow your saw to cool completely, cover the bar and chain and properly secure to avoid turnover, fuel spillage or damage.
3. Drain oil and fuel tank before storing for more than 30 days.
4. Store in a dry area out of the reach of children and away from where fuel vapors can reach an open flame from hot water heaters, furnaces, etc.

KNOW YOUR CHAIN SAW

A. INTRODUCTION

The information found in this manual will help you properly prepare your chain saw for use, understand how to operate your saw safely, and perform maintenance required to keep your unit in good working condition.

Your saw has been designed with safety in mind and includes the following safety features as standard equipment:

- Spark Arrestor
- Handguards
- Counter-Vibe® Vibration System
- Lo-Kick® Guide Bar
- Guard Link Chain

The chain saw should never be operated unless these devices are properly installed on the unit. The Lo-Kick® Guide Bar and Guard Link Chain have been designed to reduce the hazard of kickback. You should thoroughly read and understand the section, "Controlling Kickback" on page 11.

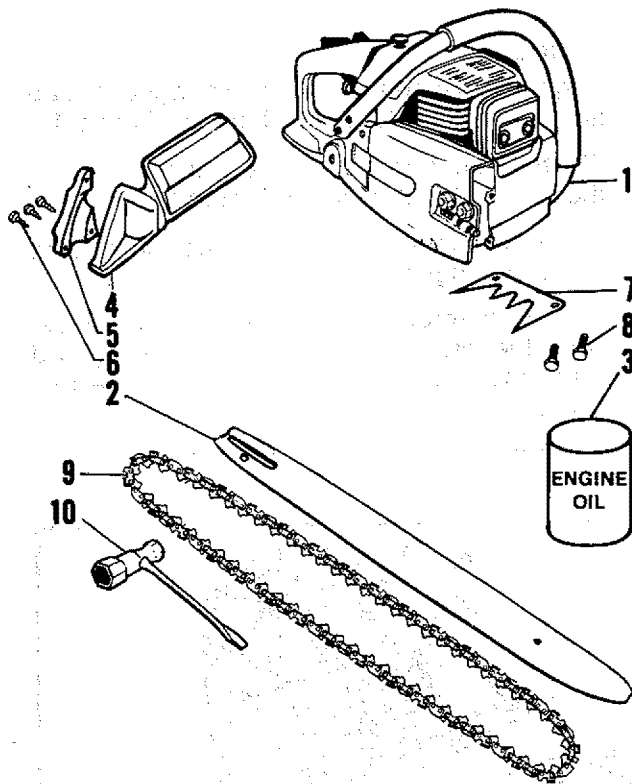

B. STATE AND LOCAL ORDINANCE REQUIREMENTS

Your saw is equipped with a temperature limiting muffler and spark arresting screen which meets the requirements of California Codes 4442 and 4443. All U.S. forest land and the states of California, Maine, Washington and Oregon require many internal combustion engines to be equipped with a spark arrestor screen and a temperature limiting muffler by law.

If you operate a chain saw in a state or locale where such regulations exist, you are legally responsible for maintaining the operating condition of these parts. Failure to do so could subject you to liability or to a fine. Muffler and spark arrestor maintenance is found on page 19.

C. CARTON CONTENTS

After you unpack the carton:

1. Check the contents against the list below.
2. Examine the items for damage.
3. Notify your Sears Store immediately if a part is missing or damaged.

KEY NO. CARTON CONTENTS:

QTY.

1	Power Head	1
2	Guide Bar	1
3	8 oz. can, 2-Cycle Engine Oil	1
—	Loose Parts Bag (not shown)	1

LOOSE PARTS BAG CONTENTS:

—	Operator's Manual (not shown)	1
4	Handguard	1
5	Cap-Handguard	1
6	Screws-Handguard	3
7	Spur	1
8	Screw-Spur	2
9	Chain	1
10	Srench	1

PREPARING YOUR SAW FOR USE

A. GETTING READY

1. READ YOUR OPERATOR'S MANUAL CAREFULLY.

Your Operator's Manual has been developed to help you prepare your saw for use and to understand its safe operation. It is important that you read your manual completely to become familiar with the unit *before* you begin assembly.

2. HAVE THE FOLLOWING AVAILABLE:

- Protective gloves
- Approved, marked fuel container
- One gallon leaded or unleaded, regular gasoline
- Bar and Chain Lubricant (see page 9).
- Scrench**—provided with your unit. No other tool is necessary for assembly. The long end of the tool can be used as a slotted screwdriver. The small pipe end can be used as a socket wrench. The larger pipe end can be used to remove the spark plug.

B. ATTACHING THE HANDGUARD

The Handguard is a protective device designed to help prevent your hand from coming in contact with the cutting chain should your hand slip off the handlebar. It will not eliminate the possibility of injury from kickback or loss of control of the saw.

WARNING!

Do not use the saw without the handguard in place.

- Lift and carry the chain saw by the handlebar or rear handle, not by the handguard.
- Keep the handguard securely fastened at all times. Check the handguard screws each time the saw is used.

To install:

1. Align the Handguard and Handguard Cap around the handlebar as shown in Figure 1.
2. Fit the mounting pin on the Handguard into the hole in the handlebar. Figure 1.
3. Insert the 3 mounting screws into the 3 holes on the Handguard Cap.
4. Turn each screw a little at a time clockwise, until the Handguard Cap and Handguard meet and there is no gap between the two parts.

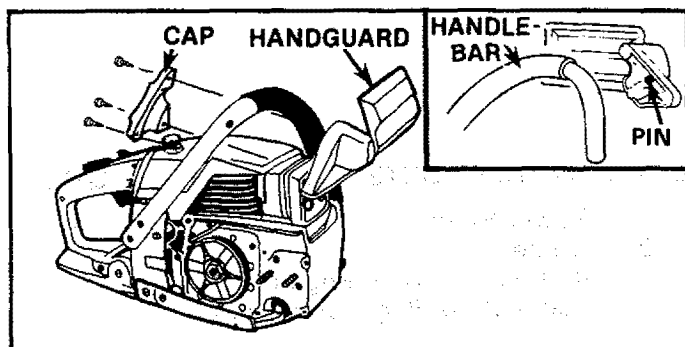

Figure 1

C. ATTACHING THE SPUR

The spur is a special piece of equipment designed to assist the cutting operation. When assembled to the saw, the spur will dig into the tree or log and:

- relieve contact pressure adding ease to the sawing operation.
- allow the saw to be more easily rotated or pivoted into the cut.

To Install:

1. Remove Bar Clamp Nuts, Bar Clamp and Guide Bar Plates.
2. Align the spur over the two holes on the bar clamp side of the saw. Figure 2.
3. Insert the two screws and tighten evenly and securely.

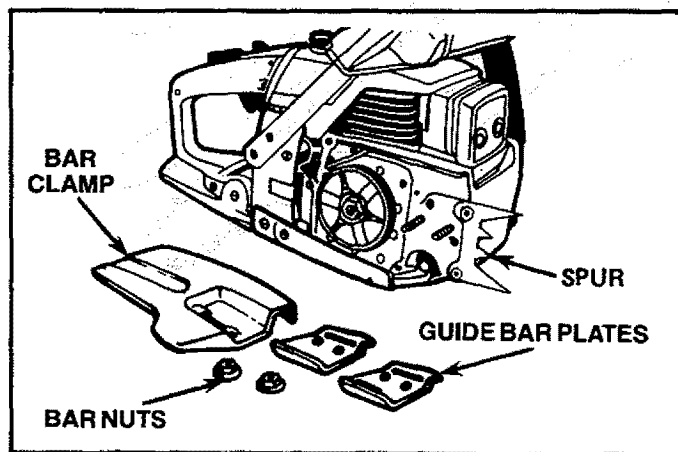

Figure 2

D. ATTACHING THE BAR AND CHAIN

CAUTION: Wear protective gloves when handling or operating your saw. The chain is sharp and can cut you even when it is not moving!

- Your saw is equipped with a Lo-Kick® Guide Bar and a Guard Link Chain designed to help reduce kickback.
- Always use the Lo-Kick® Guide Bar and the Guard Link Chain specified for your chain saw model, when replacing these parts.

WARNING!

Do not start engine without guide bar and chain completely assembled. Otherwise the clutch can come off and serious personal injury could result.

- a. Install the Inner Guide Plate over the bar mounting studs. Figure 3.

NOTE: Be sure the Inner Guide Plate curves or flanges toward the saw frame away from the Guide Bar. Figure 4.

- b. Mount the Guide Bar with the slotted end over the bar mounting studs. Figure 5.

NOTE: Be sure the Guide Bar is positioned with the round hole below the large slot.

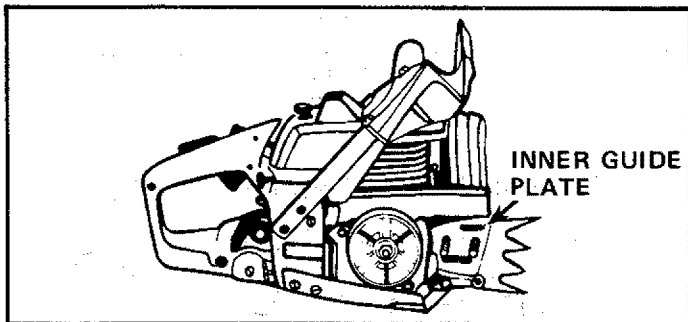

Figure 3

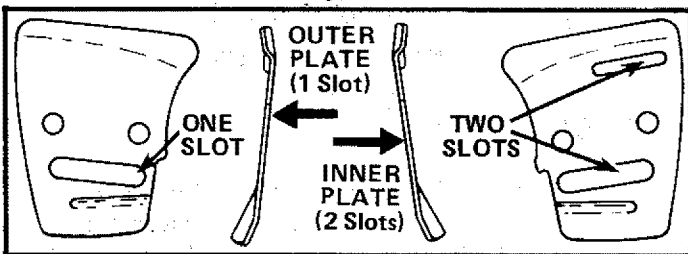

Figure 4

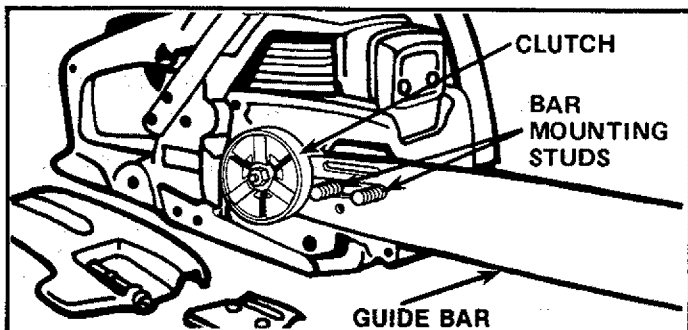

Figure 5

WARNING!

Never try to install the bar upside down to avoid increasing the hazard of kickback.

- c. Hold chain with cutters facing as shown in Figure 6.
- d. Place chain over and behind the clutch drum onto the sprocket.
- e. Slide Guide Bar to the rear of the saw as far as possible.
- f. Fit the bottom of the drive links between the teeth in the sprocket.
- g. Start at the top of the bar and fit the chain drive links into the groove around the Guide Bar. Figure 6.
- h. Pull the Guide Bar forward until the chain is snug in the guide bar groove. Figure 7.
- i. Install the outer guide plate. Figure 3.
- j. Install the Bar Clamp by sliding the bar clamp over the mounting studs and fitting the bar-adjusting pin into the round hole in the Guide Bar. Figure 8.
- k. Replace the Bar Mounting Nuts and tighten finger tight *only*.
- NOTE:** The Bar Clamp nuts must be slightly loose to tension the chain correctly.
- l. Follow "Chain Tension" instructions, page 8.

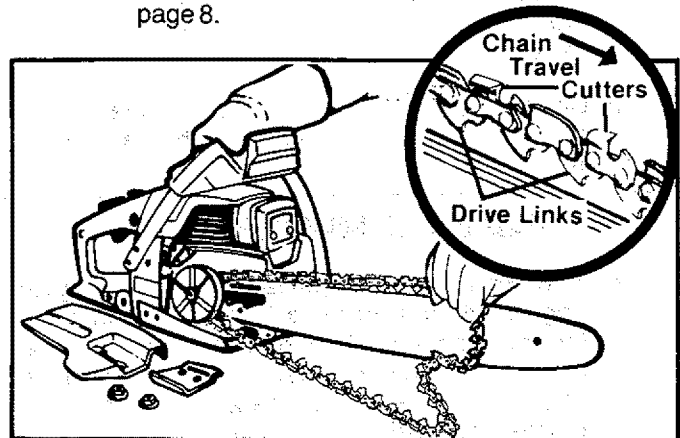

Figure 6

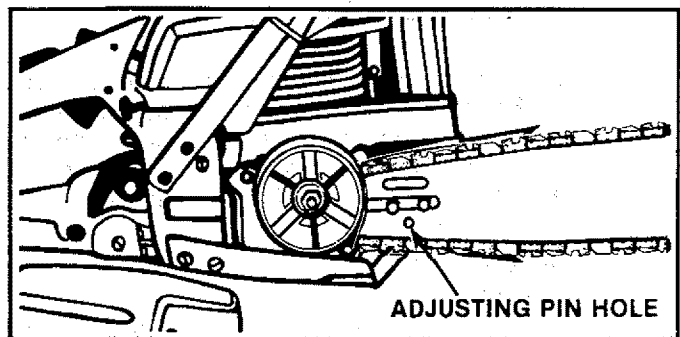

Figure 7

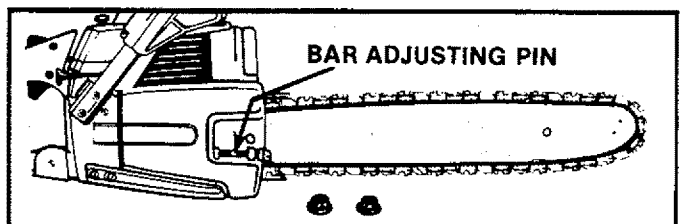

Figure 8

E. CHAIN TENSION

- **Correct chain tension is very important:**
 - a loose chain will wear the bar and itself.
 - a loose chain can jump off the bar while you are cutting.
 - a tight chain can damage the saw and/or break.
- **Chain tension is correct when the chain:**
 - can be lifted about 1/8" from the Guide Bar at a point near the middle of the bar, and
 - will move freely around the bar.
- **The chain stretches during use, especially when new. Check tension:**
 - each time the saw is used
 - more frequently when the chain is new
 - as the chain warms up to normal operating temperature

- **The Bar Clamp Nuts must be slightly loose to tension the chain correctly.**

1. Hold the tip of the Guide Bar up and turn the Adjusting Screw just until the chain does not sag beneath the Guide Bar. Figure 9.

NOTE: Turn screw clockwise to tighten tension. Turn screw counterclockwise to loosen tension.

2. Check the tension by lifting the chain from the Guide Bar at the center of the bar. Figure 10.

3. Continue turning the Adjusting Screw until the tension is correct.
4. Hold the tip of the Guide Bar up and tighten the Bar Clamp Nuts with the Srench.
5. Recheck tension.

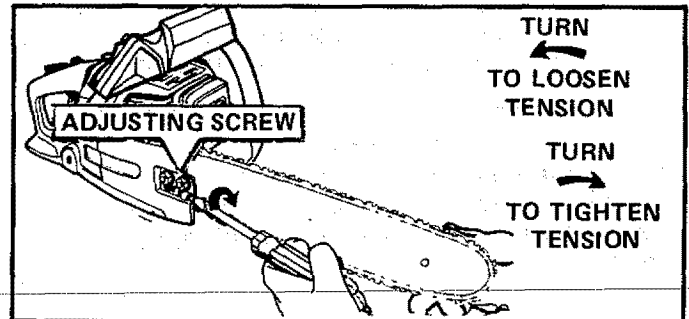

Figure 9

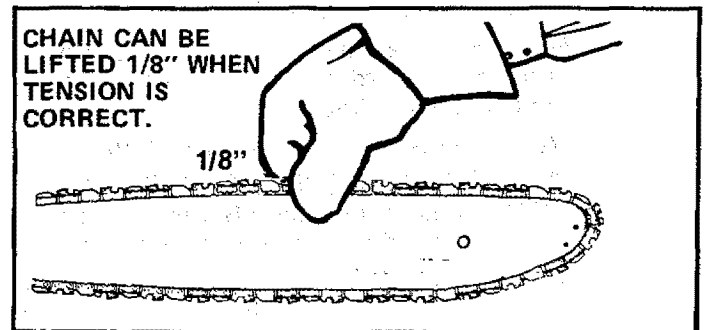
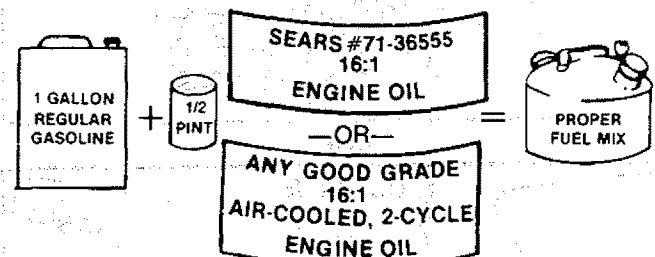

Figure 10

F. ENGINE FUEL MIXTURE

- **Your chain saw is powered by a two-cycle engine which requires a fuel mixture of regular gasoline and a high quality engine oil specially made for 2-cycle, air-cooled engines.** The internal design of the 2-cycle engine requires lubrication of moving parts. Lubrication is provided when you use the recommended mixture of gasoline and oil.
- **Gasoline must be clean and not over two months old.** After a short period of time, gasoline begins to chemically break down and will form compounds that can cause hard starting and damage in 2-cycle engines.
- **The correct measure of gasoline to oil is very important.**
 - Too much oil in the mixture will foul the spark plug.
 - Too little oil will cause the engine to over-heat resulting in damage.
- **Mix the fuel thoroughly in a container since gasoline and oil do not readily combine. Do not try to mix fuel directly in the fuel tank.**

1. USE THE FOLLOWING FUEL MIXTURES:



2. DO NOT USE:

- **BIA Oil (Boating Institute of America)**
 - Does not have proper additives for air-cooled, 2-cycle engines and could cause damage.
- **AUTOMOTIVE OIL** —
 - Does not have proper additives for 2-cycle engines and could cause damage.
- **GASOLINE CONTAINING ALCOHOL — (High Test, Premium or Gasohol)**
 - Stiffens critical carburetor fuel metering elements and causes engine damage from overheating.
 - Increases vaporlock.
 - Attracts water causing corrosion damage.

3. HOW TO MIX FUEL

- Pour one-half of the gasoline into an approved, marked container. *Do not try to mix oil and gasoline directly in the fuel tank.*
- Add entire measure of 2-cycle Engine Oil.
- Mix.
- Add remainder of gasoline.
- Mix thoroughly for one minute.

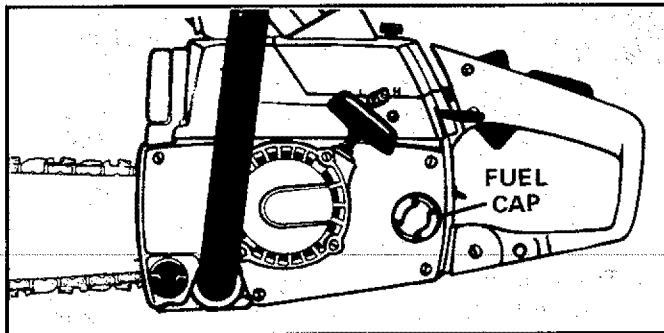

Figure 11

G. BAR AND CHAIN OIL

- The guide bar and cutting chain require continuous lubrication in order to remain in operating condition. Lubrication is provided by the automatic oiler system when the oil tank is kept filled.
 - Lack of oil will quickly ruin the bar and chain.
 - Too little oil will cause overheating shown by smoke coming from the chain and/or discoloration of the guide bar rails.
- Use Sears Bar and Chain Lubricant #71-36554 or clean SAE 30W oil.
- In freezing weather oil will thicken, making it necessary to thin bar and chain oil with a small amount of Diesel Fuel #1 or Kerosene. Bar and chain oil must be free flowing for the oil system to pump enough oil for adequate lubrication.

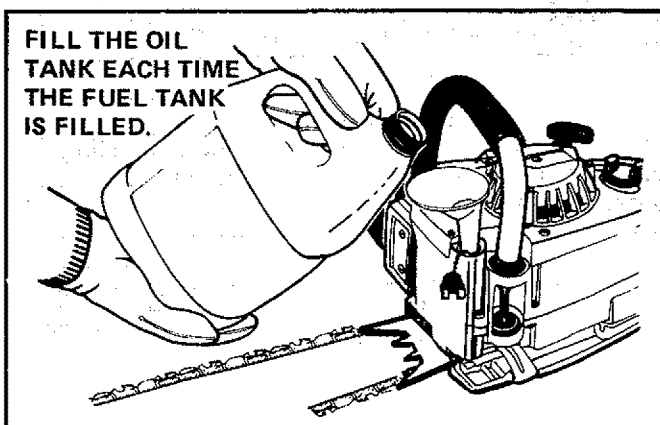

Figure 12

4. IMPORTANT POINTS

- Eliminate all sources of sparks or flame in the areas where fuel is mixed, poured, or stored. There should be no smoking, open flames or work that could cause sparks.
- Mix, pour and store fuel in an approved, marked, container and in a well-ventilated area. Gasoline vapors are harmful to your health and are a serious fire hazard. Use a funnel or spout when pouring fuel.
- Avoid over filling the fuel tank. Allow 3/4 inch for expansion. Tighten Fuel Cap securely. Figure 11.
- Wipe up all fuel spills. Wipe off any fuel spilled on the saw. Completely dry the saw before using.
- Move at least 10 feet (3 meters) away from fuel and fueling site before starting the engine.

1. USE THE FOLLOWING:

- 30°F or above — Lubricant — undiluted.
- 30°F - 0°F — 95% lubricant to 5% Diesel Fuel #1 or Kerosene.
- Below 0°F — 90% lubricant to 10% Diesel Fuel #1 or Kerosene.

2. HOW TO FILL THE OIL TANK

- Stop the engine.
- Turn saw on its side with oil cap up. Figure 12.
- Loosen cap slowly and wait for pressure in the tank to be released before removing the cap.
- Fill the oil tank.
- Replace the oil cap securely.

3. IMPORTANT POINTS TO REMEMBER

- Fill the oil tank each time you refill the fuel tank to ensure there will be sufficient oil for the chain whenever you start and run the saw.
- The saw will use about 1/2 tank of chain oil for each tank of fuel mixture. If less oil is used, check for a plugged oil hole in the guide bar.
- It is normal for a small amount of oil to appear under the saw after the engine stops. This is due to oil draining from the bar and chain when not in use.

USING YOUR SAW

A. CONTROL DEVICES

Understanding the control devices on your saw is an important part of learning how to properly and safely operate the unit. Figure 13.

1. The **Ignition Switch** is a toggle switch which is moved up for the "Start" position and moved down for the "Stop" position.
2. The two-position **Choke** helps to start the saw by controlling the air flow to the fuel system.
3. The **Trigger** accelerates and controls the speed of the engine and is designed to be used with the Throttle Lock.
4. The **Throttle Lock** is a control feature which prevents the Trigger from becoming accidentally engaged. The Throttle Lock must be pressed before the Trigger can be activated.
5. The **Throttle Detent Button** holds the Throttle Lock and Trigger in position while the engine is being started. Release the Throttle Detent Button after the engine is started by lightly squeezing the trigger.

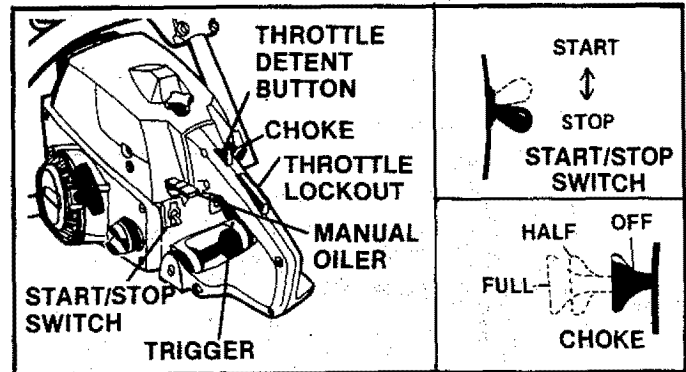

Figure 13

6. The **Manual Oiler** is placed to be operated by your right thumb. Use the manual oiler to supplement the automatic oiler:
 - during a long felling cut
 - when cutting into a log or tree which is greater in diameter than the length of the guide bar.
 - anytime an additional supply of oil is desired.

B. STARTING INSTRUCTIONS

1. IMPORTANT POINTS

- a. Push down on the throttle lockout, squeeze the trigger, press and hold down the throttle detent button, then slowly release the trigger.
- b. Engage choke according to "Starting Instructions" below.
- c. Hold saw firmly with the saw chain free to turn without contacting any object. Figure 14.
- d. Pull starter rope quickly, using no more than 15-18 inches of rope per pull. Using the full length of the starter rope may cause it to break. Do not let the starter rope snap back. Hold the handle and let the rope rewind slowly.
- e. Release the throttle detent button after engine starts, allowing the engine to idle. The chain must not move when the engine runs at idle speed. If correction is required, refer to Carburetor Adjustments, page 22.
- f. Stop engine by moving the ignition switch to the "STOP" position (Figure 13).

WARNING!
Always wear gloves; safety footwear; snug-fitting clothing; and appropriate eye, hearing, and head protection devices when operating a chain saw.

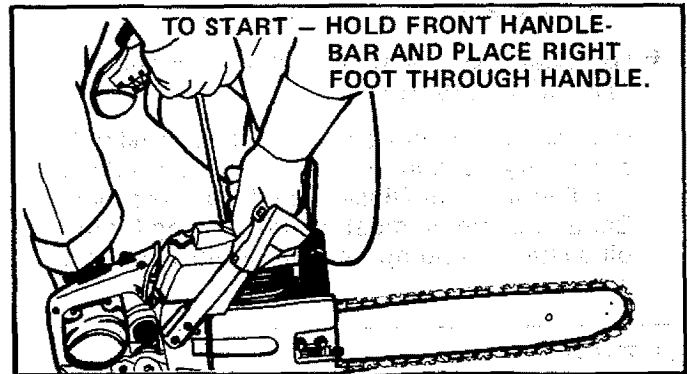

Figure 14

WARNING!
Avoid bodily contact with the muffler when starting a warm engine. The muffler can become very hot and can cause serious burns.

2. STARTING PROCEDURE

	Move ignition switch to start	Pull choke knob to full choke	Press throttle lock and squeeze trigger	Press throttle detent button release trigger	Pull starter rope until engine fires	Push choke knob in	Pull starter rope until engine runs	Squeeze trigger to release throttle detent
a. Cold Engine	X	X	X	X	3-5 times	X	X	X
b. Warm Engine	X	choke off	X	X			1-2 times	X
c. Refueled Engine after running out of gas	X	X	X	X	3-5 times	X	X	X
d. Flooded Engine	X	choke off	X	X			X	X
e. Cold Weather starting	X	X	X	X	3-5 times	half choke* (out of cut)	X	X

* Allow engine to warm-up thoroughly on half-choke, then move choke to the "Off" position. Do not cut with the choke at the "On" or "Half" position. Figure 13.

C. CONTROLLING KICKBACK

Kickback is a dangerous reaction that can cause serious personal injury. Carefully study this manual before you make the first cut with your new saw. You must understand what causes kickback, how you can reduce the chance of kickback, and how you can remain in the best control of the saw if kickback does occur.

1. WHAT CAUSES KICKBACK

Kickback can occur when the moving chain contacts an object at the tip or nose of the guide bar. This contact causes the chain to dig into the object and stops the chain for an instant. The result is a lightning fast, reverse reaction which kicks the saw tip up and back toward the operator. The operator can lose control of the saw and the cutting chain can cause serious personal injury if it contacts any part of the body.

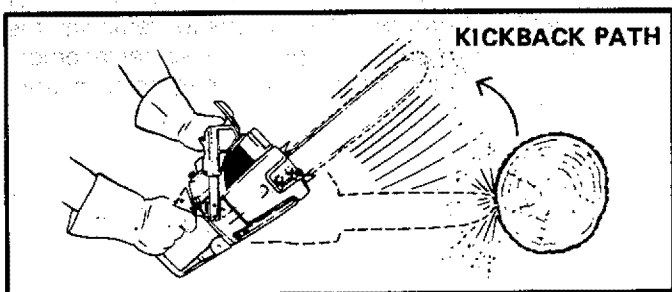

Figure 15

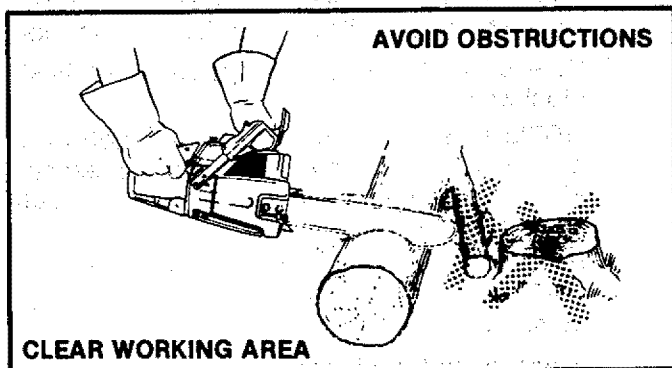

Figure 16

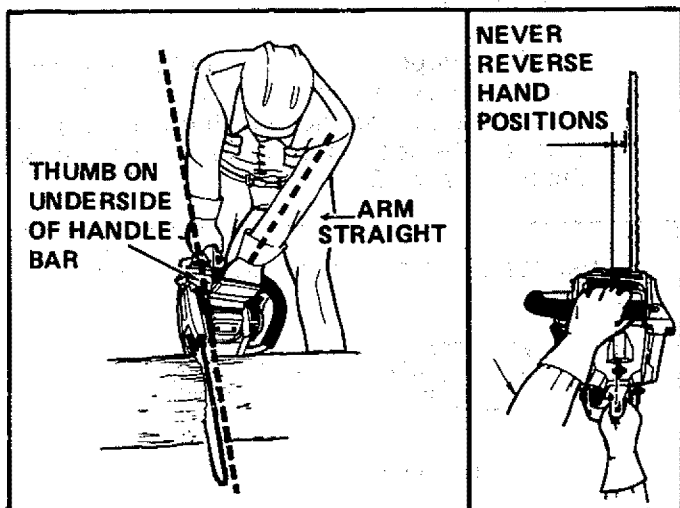

Figure 17

2. REDUCE THE CHANCE OF KICKBACK

- Recognize that kickback can happen. By understanding and knowing about kickback, you are better equipped to deal with an occurrence.
- Never let the moving chain contact any object at the tip of the guide bar. Figure 15.
- Keep the working area free from obstructions such as other trees, branches, rocks, fences, stumps, etc. Figure 16. Eliminate or avoid any obstruction that your saw chain could hit while you are cutting through a particular log or branch.
- Keep your saw chain sharp and properly tensioned. A loose or dull chain can increase the chance of kickback.
- Begin and continue cutting at full throttle. If the chain is moving at a slower speed, there is greater chance for kickback to occur.
- Cut one log at a time.
- Use extreme caution when re-entering a previous cut.
- Do not attempt plunge cuts.
- Watch for shifting logs or other forces that could close a cut and pinch or fall into the chain.
- Use the Lo-Kick® Guide Bar and Guard Link Chain specified for your particular saw. These devices have been designed to reduce the hazard of kickback.
- Use extra caution if your saw is equipped with the Power Sharp® System. The Power Sharp® saw is equipped with a Lo-Kick® Guide Bar and a Guard Link Chain. However, due to the chain requirements of the built-in sharpening mechanism, the kickback force from the Power Sharp® chain may be greater than that from other Guard Link chains.

3. MAINTAIN THE BEST CONTROL

- Keep a good firm grip on the saw with both hands. Figure 17. A firm grip can neutralize kickback and help you maintain control of the saw. Keep the fingers of your left hand encircling and your left thumb under the front handlebar. Keep your right hand completely around the rear handle *whether you are right handed or left handed*. Keep your left arm straight with the elbow locked.
- Position your left hand on the front handlebar so it is in a straight line with your right hand on the rear handle. Figure 17. Never reverse right and left hand position.
- Stand with your weight evenly balanced on both feet.
- Stand slightly to the left side of the saw, to keep your body from being in a direct line with the cutting chain. Figure 17.
- Do not overreach. You could be drawn or thrown off balance and lose control of the saw.
- Do not cut above shoulder height. It is difficult to maintain control of the saw above shoulder height.

USING THE POWER SHARP® SYSTEM (MODEL 358.356100)

Model 358.356100 is equipped with a Power Sharp® System that will perform approximately 80% of the sharpening necessary for the saw chain. The Power Sharp® System uses a built-in grinding stone to sharpen the cutter top plates and set depth gauges. As the built-in sharpener is used, the cutter side plates gradually will be altered. Hand filing is required to correct the cutter side plates.

- **Sharpen the saw chain when:**
 - wood chips become small and powdery. Wood chips made by the chain should be about the size of the teeth of the chain.
 - saw cuts to one side.
 - saw has to be forced through the cut.

CAUTION: Always wear gloves when handling the chain. The chain can be sharp enough to cut you, even when it is too dull to cut wood.

- **Always replace the sharpening stone when**
 - sparks are no longer seen at full adjustment
 - only 1/4 inch of stone is remaining
 - stone has become cracked or damaged.
- **a new chain is installed.** The used stone will be worn to the shape of the old chain and can cause excessive wear to a new chain. Replacement chain comes supplied with Stone Cartridge Replacement #69099. Refer to replacement instructions on page 13.
- **Always remove the sharpening stone if a conventional chain is substituted for the Power Sharp® Chain.** See instructions for removing the Stone Cartridge on page 13. Use replacement chain #71-3638. Follow chain sharpening instructions on page 18.

A. AUTOMATIC SHARPENING

1. Stop the engine.
2. Place the saw on a solid, flat surface and make sure that the chain will not contact any object.
3. Adjust the chain with correct tension. Refer to Chain Tension, page 8.

IMPORTANT: The chain *must be* tensioned correctly for proper sharpening to occur.

4. Start the engine and operate at half to three-quarters throttle during steps "5", "6", "7", and "8".

NOTE: Saw *must be* running at half to three-quarters throttle *before* knob is pressed.

5. Push the Power Sharp® Knob down slowly until fully pressed down. Figure 19.

NOTE: If stone should contact chain before knob is fully pressed down, release knob and turn knob counterclockwise until condition does not exist. Repeat Step "5" again.

6. Turn knob slowly clockwise until sparks can be seen as shown in Figure 19.

NOTE: Proper sharpening occurs when a light flow of sparks is seen. Improper sharpening is shown by a heavy flow of sparks or no sparks.

7. Release knob and turn *one* additional "click" clockwise.

NOTE: It is important to turn the knob only one "click" each time the knob is pressed. More turns will result in making the chain dull instead of sharp.

8. Press knob firmly against chain and hold for 10-15 seconds or until sparks can no longer be seen.
9. Release knob and stop the engine.
10. Inspect chain cutters.

NOTE: A properly sharpened cutter will show grinding marks across its entire width. Figure 20. If cutters do not appear sharp or burrs are seen on the top front of the cutters, repeat Steps "7" and "8".

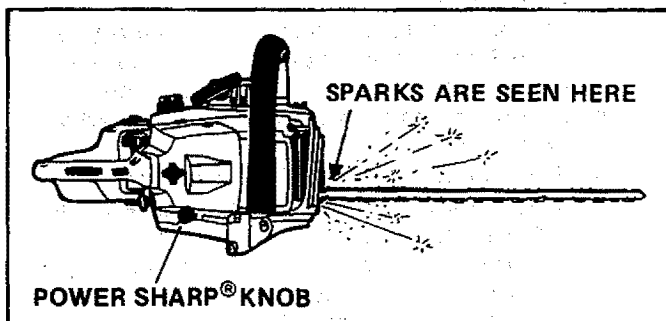

Figure 19

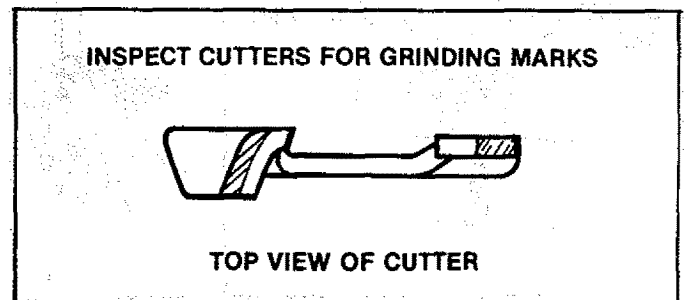

Figure 20

B. HAND FILING

Sharpen the side plates by hand after every 3rd to 5th time the Power Sharp® System is used.

Items Required:

Gloves flat file
5/32" file vise
file holder

NOTE: If abrasive materials such as rocks, nails, sand or dirt are contacted by the chain, the side plates should be checked more often. Damage to the cutters caused by abrasive materials usually results in discoloration spots where the chrome has been worn away. Cutter side plates should be filed until these spots are removed.

1. Stop the engine.
2. Adjust the chain for proper tension, page 8.
3. Clamp the bar in a vise to hold the chain steady. Do not clamp the chain.

NOTE: Work at the midpoint of the bar, moving the chain forward with a screwdriver as each cutter is filed.

4. Support the square rod on the file holder (with 5/32" round file) on cutter top plate. Figure 21.
5. Hold the file holder level with the 22° guide mark parallel to guide bar. Figure 22.
6. File from inside toward outside of cutter in one direction only — 2 or 3 strokes per side plate edge should be enough. Figure 23.

NOTE: Avoid hitting the top edge of the cutters when filing the side plate.

7. Maintain a 1/32" side plate projection. Figure 24.
8. File all side plates on one side of the chain, then move to the other side of bar and file remaining side plates.

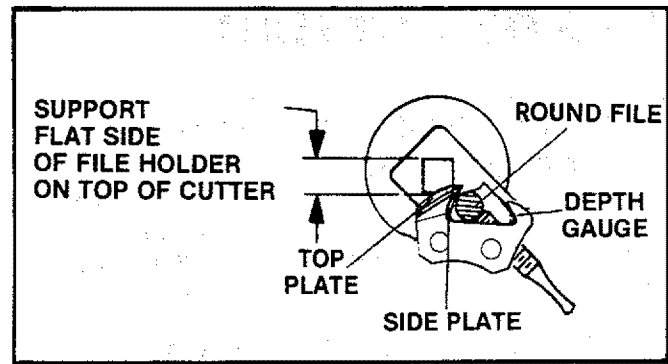

Figure 21

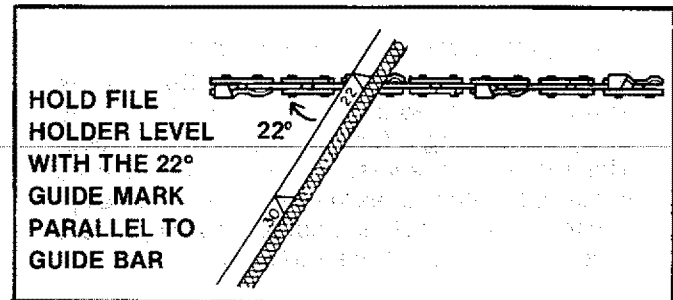

Figure 22

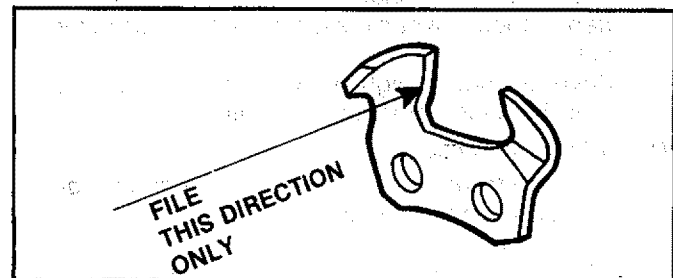

Figure 23

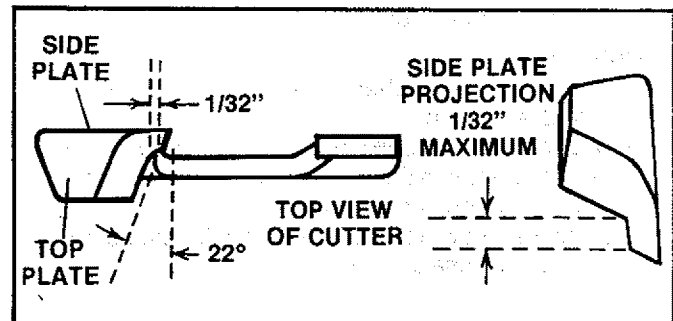

Figure 24

C. REPLACE OR REMOVE THE STONE AND CARRIER ASSEMBLY

1. Remove Carburetor Cover and Bar Clamp.
2. Remove the two screws which hold cartridge assembly to crankcase. Figure 25.
3. Discard old assembly.
4. Install new cartridge assembly.

NOTE: Be careful not to let the Slide Button fall out.

5. Reinstall Carburetor Cover and Bar Clamp.

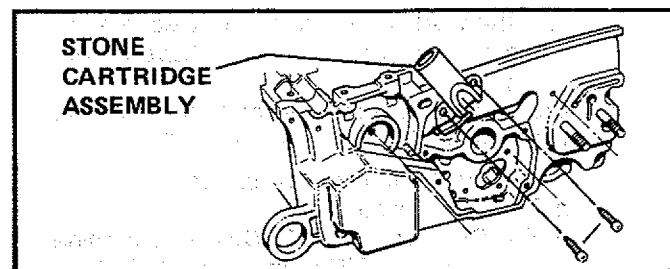

Figure 25

TYPES OF CUTTING

A. BASIC CUTTING TECHNIQUE

1. IMPORTANT POINTS.

- Cut wood only.** Do not cut metal, plastics, masonry, non-wood, building materials; etc.
- Stop the saw if the chain strikes a foreign object.** Inspect the unit and repair or replace parts as necessary.
- Keep the chain out of dirt and sand.** Even a small amount of dirt will quickly dull a chain and thus, increase the possibility of kickback.

2. UNDERSTAND REACTIVE FORCES

Pushback and Pull-in occur when the chain is suddenly stopped by being pinched, caught, or by contacting a foreign object in the wood.

This results in a reversal of the chain force used to cut wood and causes the saw to move in the opposite direction of chain rotation, resulting in loss of control and possible serious personal injury.

● Pushback:

- occurs when the chain, on top of the bar, is suddenly stopped when the top of the bar is used for cutting.
- drives the saw straight back toward the operator, possibly causing loss of saw control.

To avoid Pushback:

- Be extremely aware of situations or obstructions** that may cause material to stop or pinch the top of the chain.
- Do not cut more than one log at a time.**
- Do not twist the saw** as the bar is withdrawn from an under-cut.

● Pull-in:

- occurs when the chain on the bottom of the bar is suddenly stopped.
- occurs when the spike or saw housing is not held securely against the tree or limb and/or when the cut is not begun at full throttle.
- pulls the saw forward, and could cause the operator to lose control.

To avoid Pull-in:

- Always begin cutting with the engine at full throttle and the spike against the wood.**
- Use wedges made of plastic, wood, or light alloy** (never of steel or iron) to hold the cut open.

3. PROCEDURE

Practice cutting a few small logs using the following technique to get the "feel" of using your saw before you begin a major sawing operation.

- Accelerate the engine to full throttle just before entering the cut** by squeezing the Throttle Trigger.
- Begin cutting with the spur against the log.** Figure 26.
- Keep the engine at full throttle the entire time** you are cutting.
- Allow the chain to cut for you;** exert only light downward pressure. If you force the cut, damage to the bar, chain or engine can result.
- Release the throttle trigger as soon as the cut is completed,** allowing the engine to idle. If you run the saw at full throttle without a cutting load, unnecessary wear can occur to the chain, bar, and engine.
- Do not put pressure on the saw at the end of the cut** to avoid losing control when the cut is complete.
- Stop the engine before setting the saw down** after cutting.

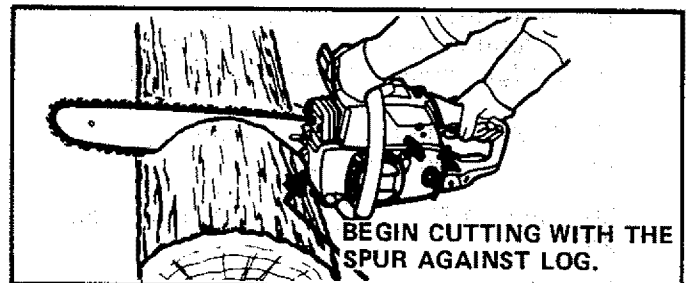

Figure 26

B. TREE FELLING TECHNIQUES

1. PLAN YOUR SAWING OPERATION CAREFULLY IN ADVANCE

- Clear the work area.** You need a clear area all around the tree where you can have secure footing.
- Study the natural conditions that can cause the tree to fall in a particular direction:**
 - 1.) The **WIND** direction and speed
 - 2.) The **LEAN** of the tree
 - 3.) **WEIGHTED** with **BRANCHES** on one side
 - 4.) Surrounding **TREES** and **OBSTACLES**
- Look for decay and rot.** If the trunk is rotted, it could snap and fall toward the operator.

- Check for broken or dead branches** which could fall on you while cutting.
- Make sure there is enough room for the tree to fall.** Maintaining a distance of 2½ tree lengths from the nearest person or other objects. Engine noise may drown out warning call.
- Remove dirt, stones, loose bark, nails, staples, and wire** from the tree where cuts are to be made.
- Plan to stand on the up-hill side when cutting on a slope.**
- Plan a clear retreat path to the rear and diagonal to the line of fall.** Figure 27.

2. FELLING SMALL TREES — LESS THAN 6" IN DIAMETER

- a. If you know the direction of fall:
 - 1.) Make a single felling cut on the side away from the direction of fall.
 - 2.) Cut all the way through.
 - 3.) Stop the saw, put it down, and get away quickly on your planned retreat path.
- b. If you are not sure which way the tree will fall, use the notch method described for felling large trees.

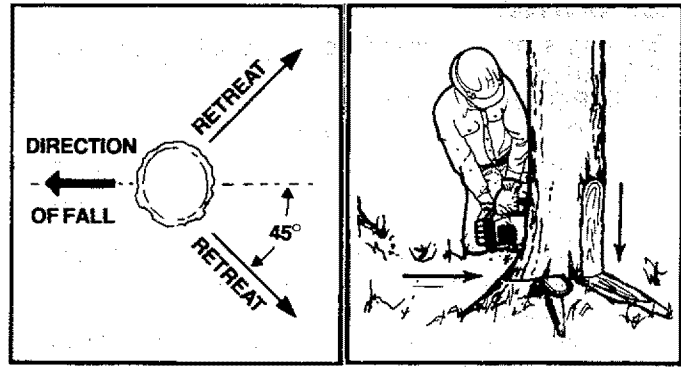

Figure 27

Figure 28

WARNING!

DO NOT CUT:

- near electrical wires or buildings.
- if you do not know the direction of tree fall.
- at night since you will not be able to see well.
- during bad weather — strong wind, snow, rain, etc.

3. FELLING LARGE TREES — 6" DIAMETER OR MORE

The notch method is used to cut large trees. A notch is cut on the side of the tree in the desired direction of fall. After a felling cut is made on the opposite side of the tree, the tree will tend to fall into the notch.

NOTE: If the tree has large buttress roots, remove before making the notch. Cut into the buttresses vertically, then horizontally. Figure 28.

- a. Make the notch cut. Figure 29.
 - 1.) Cut the bottom of the notch first, through 1/3 of the diameter of the tree.
 - 2.) Complete the notch by making the slant cut.
 - 3.) Remove the notch of wood.
- b. Make the felling cut on the opposite side of the notch about 2" higher than the bottom of the notch.
- c. Leave enough uncut wood between the felling cut and the notch to form a hinge. Figure 30.

NOTE: The hinge helps to keep the tree from twisting and falling in the wrong direction.

- d. Use a wedge if there is any chance that the tree will not fall in the desired direction.

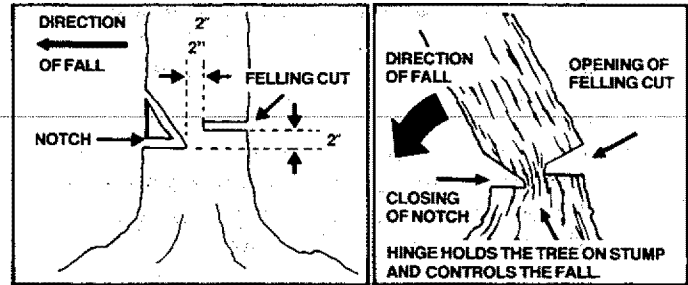

Figure 29

Figure 30

NOTE: Before the felling cut is complete, drive wedges to open up the cut when necessary to control the direction of fall. Use wood, plastic or light alloy wedges but *never* steel or iron, to avoid kickback and chain damage.

- e. Be alert for signs that the tree is ready to fall:
 - 1.) cracking sounds
 - 2.) widening of the felling cut
 - 3.) movement in the upper branches.
- f. As the tree starts to fall, *stop the saw; put it down, and get away quickly on your planned retreat path.*
- g. Be extremely cautious with partially fallen trees that may be poorly supported. When a tree doesn't fall completely, set the saw aside and pull down the tree with a cable winch, block and tackle or tractor. Do not cut it down with your saw to avoid injury.

DON'T PUT YOURSELF IN THESE POSITIONS

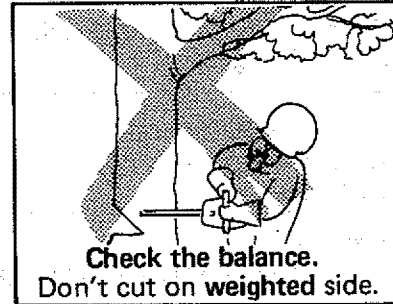
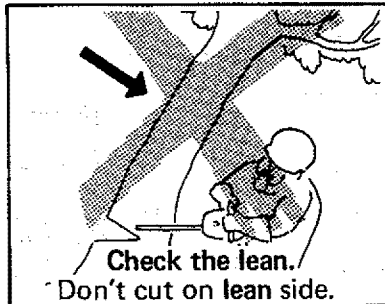
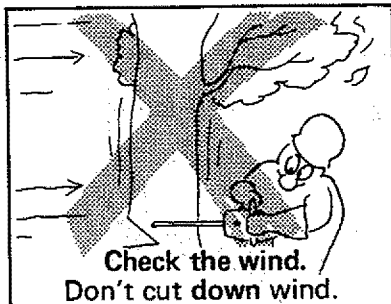

C. BUCKING

Bucking is the term used for cutting a fallen tree to the desired log size.

1. IMPORTANT POINTS

- Cut only one log at a time.
- Cut shattered wood very carefully. Sharp pieces of wood could be flung toward the operator.
- Use a sawhorse to cut small logs. Never allow another person to hold the log while cutting and never hold the log with your leg or foot.
- Give special attention to logs under strain to prevent the saw from pinching. Make the first cut on the compression side to relieve the stress on the log. (Figure 31)
- Do not cut in an area where logs, limbs and roots are tangled such as in a blown down area. Drag the logs into a clear area before cutting by pulling out exposed and cleared logs first.
- Make the first bucking cut 1/3 of the way through the log and finish with a 2/3 cut on the opposite side. As the log is being cut, it will tend to bend. The saw can become pinched or hung in the log if you make the first cut deeper than 1/3 of the diameter of the log.

2. TYPES OF CUTTING USED Figure 32.

- Overcutting** – begin on the top side of the log with the spur against the log; exert light pressure downward.
- Undercutting** – begin on the under side of the log with the top of the saw against the log; exert light pressure upward. During undercutting, the saw will tend to push back at you. Be prepared for this reaction and hold the saw firmly to maintain control.

WARNING!

If saw becomes pinched or hung in a log, don't try to force it out. You could lose control of the saw resulting in personal injury and/or damage to the saw. Stop the saw and drive a wedge of plastic, wood or light alloy into the cut until saw can be removed easily. Figure 33. Do not use a steel or iron wedge to avoid kickback and chain damage.

3. BUCKING — WITHOUT A SUPPORT

- Overcut with a 1/3 diameter cut.
- Roll log over and finish with an overcut.

4. BUCKING — USING ANOTHER LOG AS A SUPPORT (Figure 34):

WARNING!

Do not stand on the log being cut. The cut portion will roll down hill.

- In area A:
 - Undercut 1/3 of the way through the log.
 - Finish with an overcut.
- In area B:
 - Overcut, 1/3 of the way through the log.
 - Finish with an undercut.

WARNING!
Never turn the saw upside down to undercut. The saw cannot be controlled in this position.

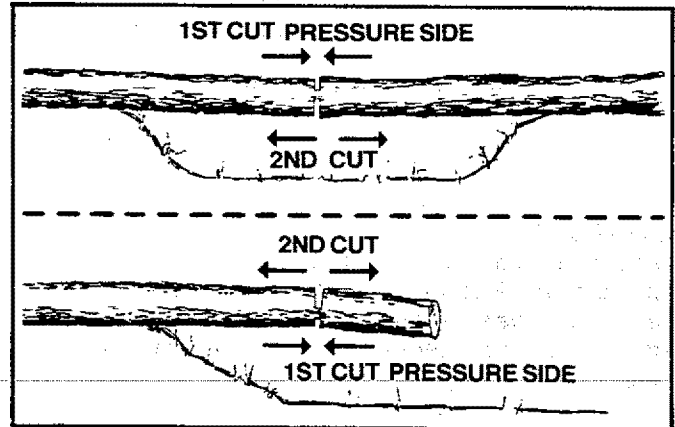

Figure 31

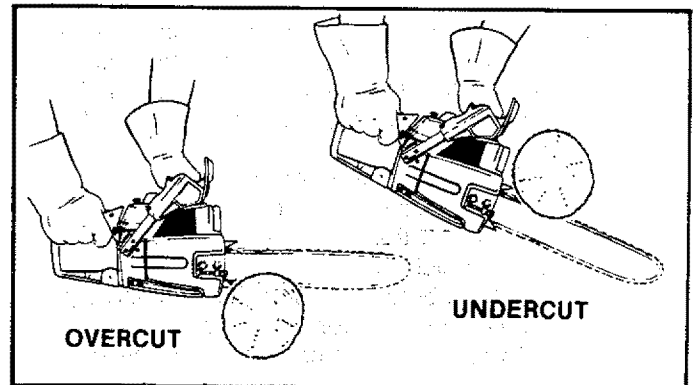

Figure 32

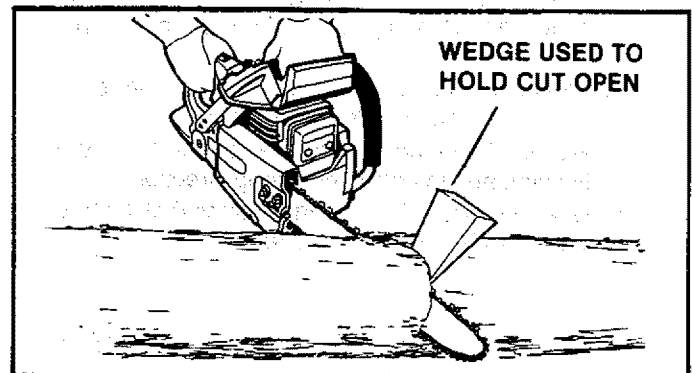

Figure 33

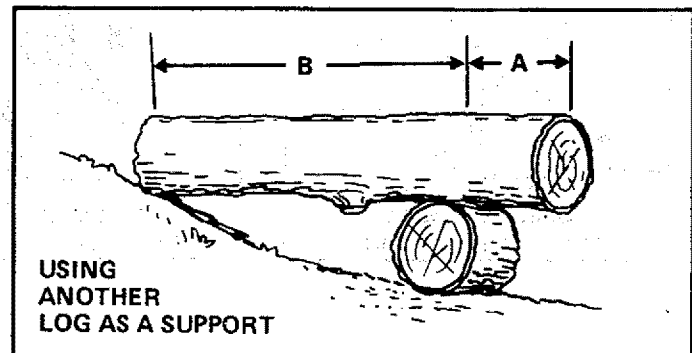

Figure 34

5. BUCKING — USING A STAND (Figure 35):

- a. In area A:
 - 1.) Undercut 1/3 of the way through the log.
 - 2.) Finish with an overcut.
- b. In area B:
 - 1.) Overcut 1/3 of the way through the log.
 - 2.) Finish with an undercut.

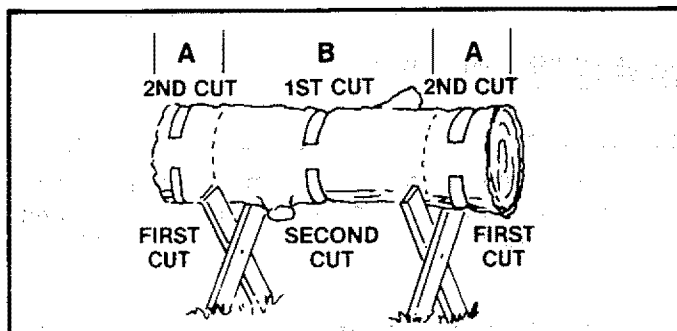

Figure 35

D. DEBRANCHING AND PRUNING

- **Work slowly, keeping both hands on the saw with a firm grip.** Maintain secure footing and balance.
- **Watch out for springpoles.** Use extreme caution when cutting small size limbs. Slender material may catch the saw chain and be whipped toward you or pull you off balance.
- **Be alert for springback.** Watch out for branches that are bent or under pressure as you are cutting to avoid being struck by the branch or the saw when the tension in the wood fibers is released.
- **Keep a clear work area.** Frequently clear branches out of the way to avoid tripping over them.

1. DEBRANCHING

- a. **Limit debranching to limbs shoulder height or below.** Always debranch a tree after it is cut down. Only then can debranching be done safely and properly.
- b. **Leave the larger lower limbs to support the tree as you work.**
- c. **Start at the base of the felled tree and work towards the top, cutting branches and limbs.** Remove small limbs with one cut. Figure 36.
- d. **Keep the tree between you and the chain.** Cut from the side of the tree opposite the branch you are cutting.
- e. **Remove larger, supporting branches with the 1/3, 2/3 cutting techniques described in the bucking section.**
 - 1.) Start with an overcut
 - 2.) Finish with an overcut
- f. **Always use an overcut to cut small and freely hanging limbs.** Undercutting could cause limbs to fall and pinch the saw.

2. PRUNING

- a. **Limit pruning to limbs shoulder height or below.** Do not cut if branches are higher than your shoulder. Get a professional to do the job.
- b. **Refer to Figure 37 for the pruning technique.**
 - 1.) Undercut 1/3 of the way through the limb near the trunk of the tree.
 - 2.) Finish with an overcut farther out from the trunk.
 - 3.) Keep out of the way of the falling limb.
 - 4.) Cut the stump flush near the trunk of the tree.

WARNING!
Never climb into a tree to debranch or prune. Do not stand on ladders, platforms, a log or in any position which might cause you to lose control of the saw.

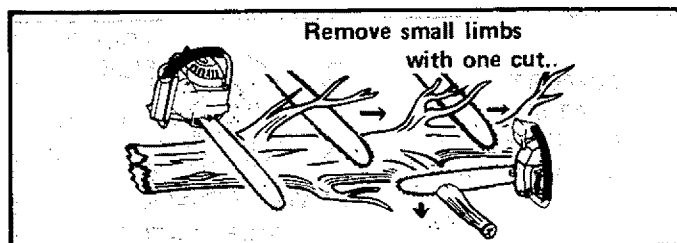
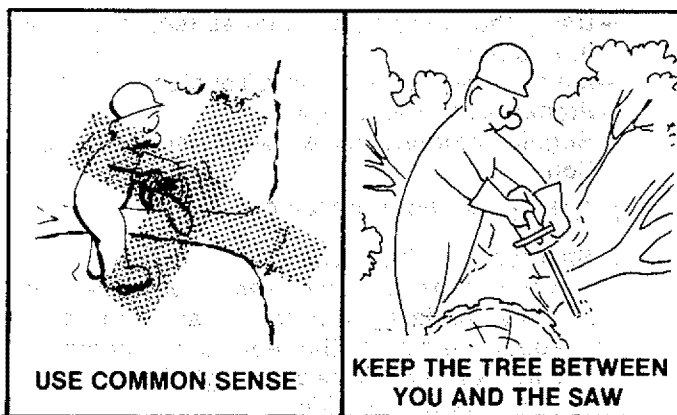

Figure 36

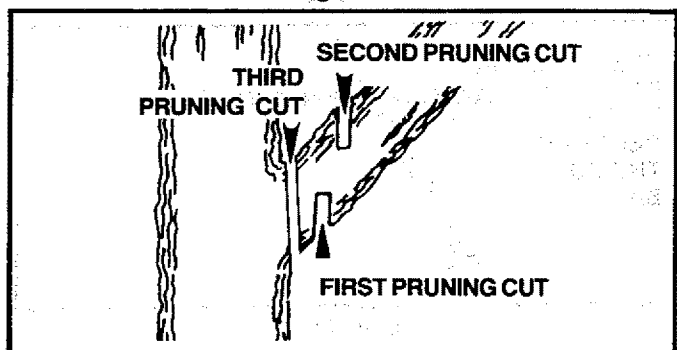

Figure 37

WARNING!
BE ALERT FOR AND GUARD AGAINST KICKBACK. Do not allow the moving chain to contact any other branches or objects at the nose of the guide bar when debranching or pruning. Allowing such contact could result in serious personal injury.

MAINTENANCE

A good maintenance program of regular inspection and care will increase the service life and help to maintain the safety and performance of your saw.

- Make all adjustments or repairs (except carburetor adjustments) with:
 - spark plug wire disconnected
 - engine cool as opposed to a unit that has just been run.

- Check the saw for loose bolts, screws, nuts, and fittings on a regular basis. Loose fasteners can cause an unsafe condition as well as damage to your saw.

WARNING!

All chain saw service, repair, adjustments and maintenance not described in this manual should be performed by your Sears Service Center.

A. GUIDE BAR AND CHAIN

Increase the service life of your Guide Bar and Chain by:

- Using the saw properly and as recommended in this manual.
- Maintaining correct Chain Tension, page 8.
- Proper lubrication, page 9.
- Regular maintenance as described in this section.

1. CHAIN MAINTENANCE

- Sharpen the chain when:
 - wood chips are small and powdery. Wood chips made by the saw chain should be about the size of the teeth of the chain.
 - saw has to be forced through the cut.
 - saw cuts to one side.

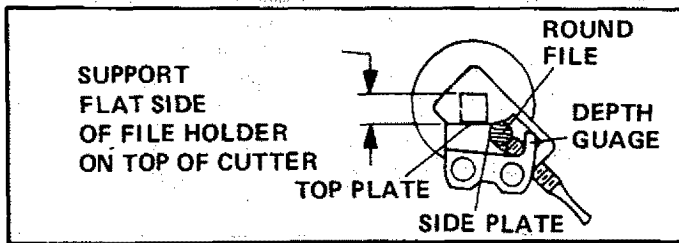

Figure 38

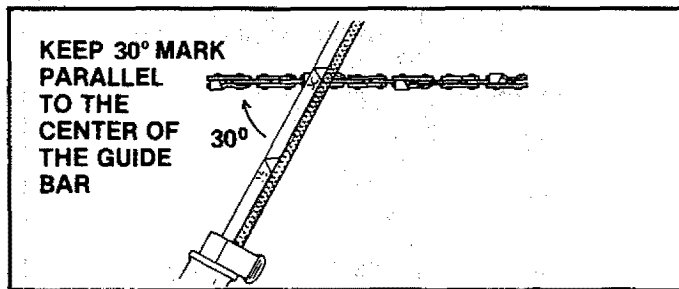

Figure 39

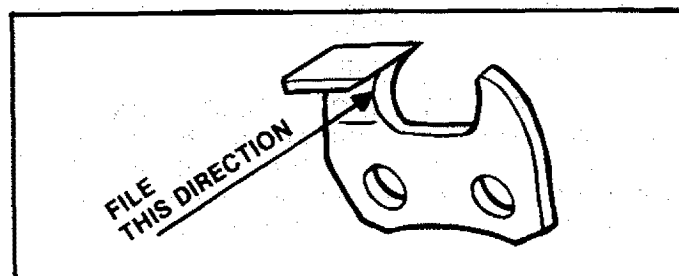

Figure 40

CAUTION: Wear protective gloves when handling the chain. The chain can be sharp enough to cut you even though it is too dull to cut wood.

- SHARPENING INSTRUCTIONS — Model 358.356090 only (For Power Sharp® Model 358.356100, see page 12)

Items required:

- | | |
|----------------|------------------|
| Gloves | Medium file |
| 7/32" file | Depth Gauge Tool |
| 6" file holder | Vise |

- Stop engine.
- Adjust the chain for proper tension, page 8.
- Clamp bar in a vise to hold chain steady. Do not clamp chain.
- Work at the midpoint of the bar, moving the chain forward by hand as each cutter is filed.
- Sharpen cutters.
 - Support flat side of file holder (with 7/32" round file) on cutter top plate. Figure 38.
 - Hold the file holder level with the 30° guide mark parallel to the center line of the bar. Figure 39.
 - File from inside toward outside of cutter, straight across, in one direction only. Use 2 or 3 strokes per cutting edge. Figure 40.
- Correct Depth Gauges.
 - Place depth gauge (Catalog No. 71-36557) tool over each cutter depth gauge. Figure 41.
 - File level with the flat file if depth gauge is higher than the depth gauge tool.
 - Maintain rounded front corner of depth gauge with a flat file. Figure 41.

NOTE: The very top of the depth gauge should be flat with the front half rounded off with a flat file.
- CHAIN REPLACEMENT
 - Replace the chain when cutters or links break.
 - See your Sears Service Center to replace and sharpen individual cutters to match your chain.
 - Always replace the worn sprocket when installing a new chain to avoid excessive wear to the chain.

2. GUIDE BAR MAINTENANCE

- Conditions which can require guide bar maintenance:
 - saw cuts to one side
 - saw has to be forced through a cut
 - inadequate supply of oil to bar and chain.
 - Check the condition of the guide bar each time the chain is sharpened. A worn guide bar will damage the chain and make cutting more difficult.
 - Replace the guide bar when:
 - the inside groove of the guide bar rails is worn.
 - the guide bar is bent or cracked.
- a. Remove the guide bar to service.
 - b. Clean oil holes at least once for each five hours of operation.
 - c. Remove sawdust from the guide bar groove periodically with a putty knife or a wire. Figure 43.

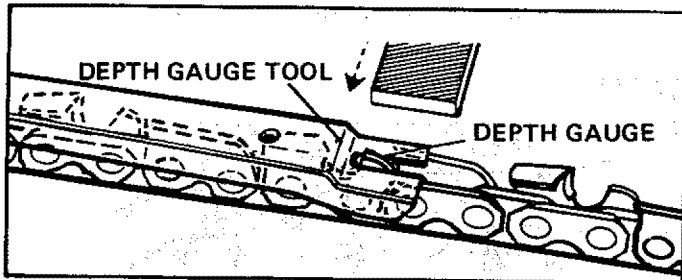

Figure 41

- d. Remove burrs by filing the side edges of the guide bar grooves square with a flat file. Figure 44.
- e. Restore square edges to an uneven rail top by filing with a flat file. Figure 44.

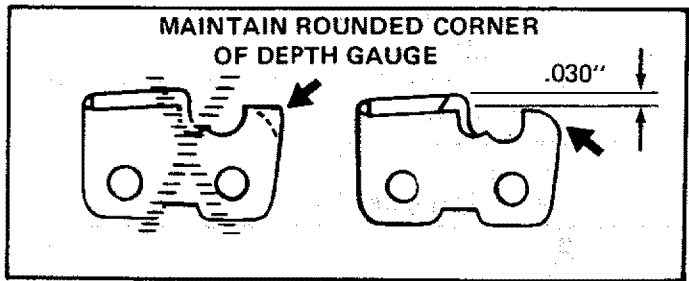

Figure 42

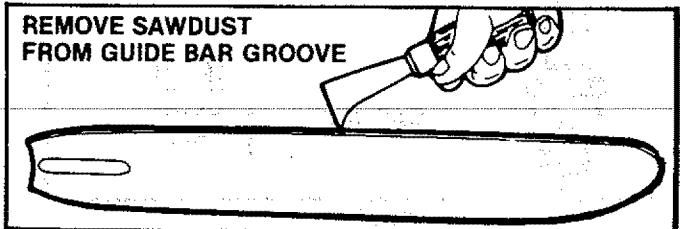

Figure 43

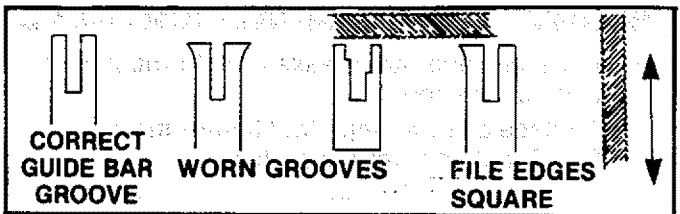

Figure 44

B. IGNITION, COOLING AND EXHAUST SYSTEMS

- Carbon deposits will build up on exhaust ports, spark arrestor, muffler, and spark plug as the saw is used. All of these parts should be cleaned at the same time to prevent engine damage, overheating, loss of power, and hard starting.
- Clean parts:
 - as required
 - at least once for each 25-30 hours of operation

1. COOLING AND EXHAUST SYSTEM

- Carbon build-up on the cooling and exhaust system can cause the engine to lose power in a cut.
- Keep the spark arrestor clean at all times.
- Replace the spark arrestor when breaks in the screen are found.

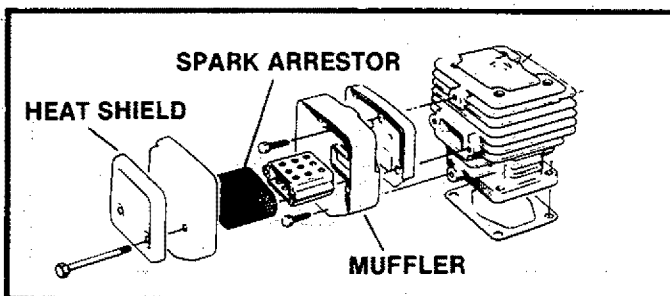

Figure 45

Items required:

- wire brush
 - 3/8" wrench
 - hardwood stick
- a. Disconnect the spark plug.
 - b. Remove the muffler, baffles, and screen. Figure 45.
 - c. Pull the starter rope until the piston moves far enough to close the exhaust ports.
 - d. Scrape the carbon deposits from the exhaust ports and surrounding exhaust chamber using a hardwood stick. Figure 46.

CAUTION: Do not use a metallic scraping tool to avoid damage to the piston.

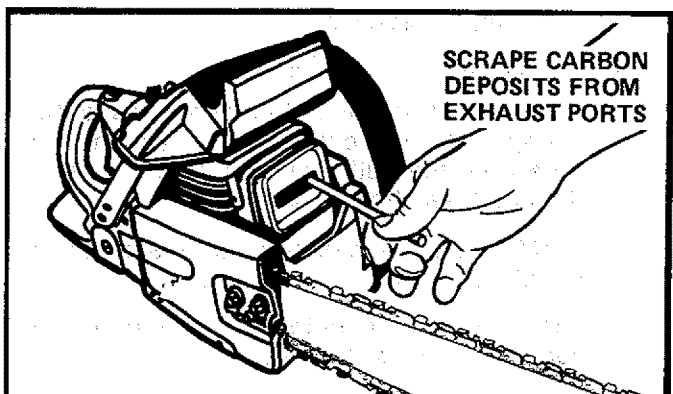

Figure 46

- e. Blow out loosened carbon with compressed air.
- f. Clean the spark arrestor screen with a wire brush or replace if breaks in the screen are found.
- g. Reassemble muffler parts.

2. SPARK PLUG

- Maintenance is indicated when the engine is hard to start.
- Keep the spark plug:
 - clean
 - properly gapped (.025")

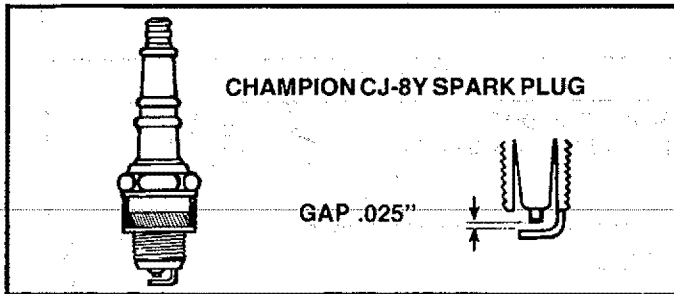

Figure 47

Items Required: Small brush, such as a tooth brush, or a pocket knife.

- a. Remove the carburetor cover.
- b. Pull the rubber connector from the spark plug and remove the spark plug from the cylinder.
- c. Clean deposits from the electrodes of the spark plug with a small brush or a pocket knife.

NOTE: Be careful when removing, cleaning, gapping and replacing the spark plug. If it is damaged, it will not work properly and must be replaced.

- d. Set the gap between the electrodes to .025 using a wire or flat gauge. Figure 47.
- e. Replace the spark plug in the cylinder and attach the rubber connector.
- f. Replace carburetor cover and knob.

C. STARTER ROPE REPAIR AND REPLACEMENT

- A starter rope that breaks next to the pulley can be repaired.
- Replace a starter rope that breaks more than 2 or 3 inches from the pulley.

WARNING!

Always wear eye protection when servicing the starter rope. The recoil spring beneath the pulley is under tension. If the spring should pop out serious personal injury could result.

NOTE: The recoil spring, located beneath the pulley, is under tension. If spring pops out, it will require considerable time and effort to reinstall. For this reason, you may want to let your Sears Service Center handle this repair. If you do try to repair the starter rope and the recoil spring pops out, take the unit to your Sears Service Center.

1. Remove the four screws on the side of the fan housing. Figure 48.

NOTE: Notice the different lengths of the screws and their proper locations while removing the screws.

2. Remove the fan housing.
3. If the starter rope is not broken, release the spring tension by pulling about 12 inches of rope from the pulley and catch the rope in the notch as shown. Figure 49.

NOTE: The tension on the starter spring will be released if the rope has broken.

4. Turn the pulley counterclockwise until the spring tension is released.

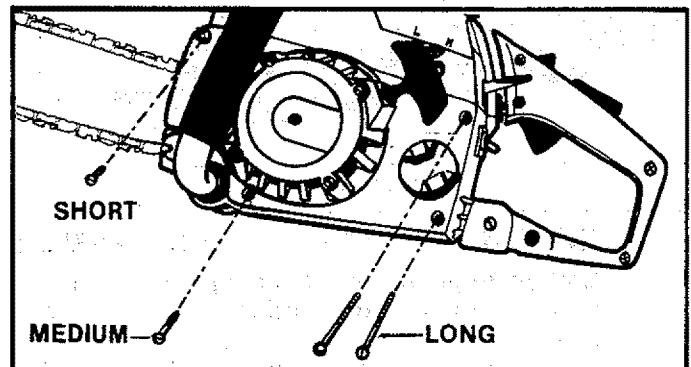

Figure 48

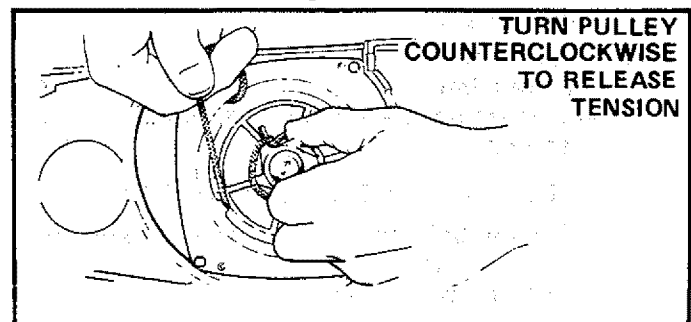

Figure 49

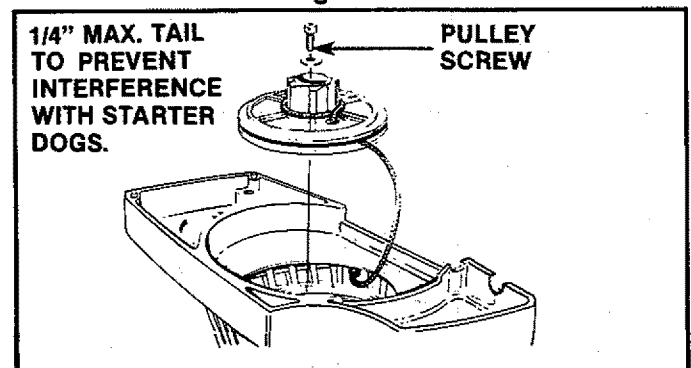





Figure 50

5. Remove the pulley screw in the center of the pulley. Figure 50.
6. Lift the pulley *carefully* while gently twisting it counterclockwise , and remove the old rope.
7. Move away from the fuel tank and burn the end of the new rope to go into the pulley.
8. Pull the burnt end while hot through a rag to smooth it.
9. Feed the rope through the housing and the round starter hole. Figure 50.
10. Put the rope into the pulley groove and up through the hole.
11. Wrap rope counterclockwise around pulley ratchet end and tuck loose end back under rope leaving a 3/8 to 1/2 inch tail.
12. Rewind all the rope onto the pulley, turning counterclockwise .
13. Set the pulley into the housing; push it down and engage the spring.
14. Replace and tighten the pulley screw.

15. Pull out 12 inches of rope and catch the rope in the slot in the pulley. Figure 51.
16. Turn the pulley 3 complete turns clockwise, , winding up the spring.
17. Hold the pulley and pull the starter rope to the full extent of length and let the rope re-wind slowly.
18. Replace fan housing with the four screws in their proper location.

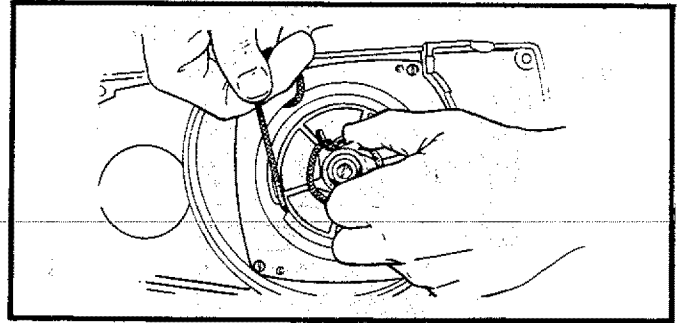

Figure 51

D. CLUTCH, AND DRUM/SPROCKET

WARNING!

Do not start engine without Guide Bar, Chain, and Bar Clamp completely assembled. The clutch can come off without the guide bar and chain completely assembled and serious injury could result. Do not loosen and spin the clutch off of the crankshaft with a power tool. The clutch shoes and drum could separate causing the clutch to violently fly apart and serious personal injury could result.

- Take the saw to your nearest Sears Service Center for full clutch inspection and service after each 100 hours of operation. It is recommended that you do not try to service the clutch yourself unless you are a competent small engine mechanic and have the proper clutch service tools. Proper disassembly and repair of the clutch is extremely important to the life of the engine and the safety of the operator.
- Clutch maintenance is required when:
 - the chain continues to turn while engine idles after the idle speed screw has been adjusted to its capacity.
 - slippage occurs during a cut.
 - a chattering noise occurs during cutting.
- Clean the clutch, drum /sprocket, and surrounding area daily during heavy use of the saw. Check to see that the clutch drum turns freely and smoothly.
- Inspect the sprocket regularly for wear. A worn sprocket will make the chain run erratically and will shorten the life of the bar and chain. Figure 52.

- Replace the sprocket whenever a new chain is installed in order to gain the full life expectancy of the chain. Use the following procedure:

Items Required: Srench
9/16" Socket Wrench
3/4" Socket Wrench

1. Remove the carburetor cover and pull the spark plug away from the rubber connector.
2. Remove the bar clamp, outer guide plate, guide bar, and chain. Figure 53.

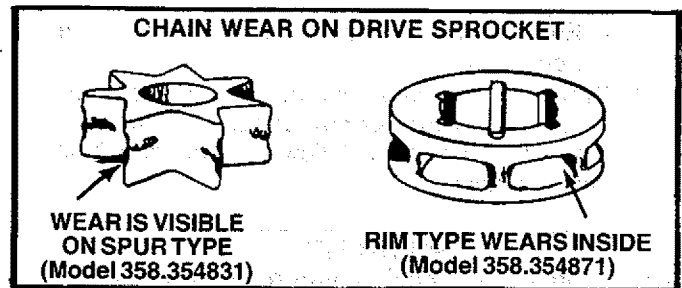

Figure 52

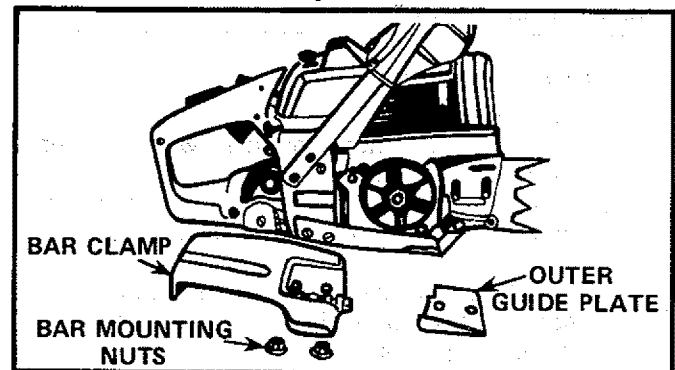

Figure 53

3. Remove the fan housing.
 4. Use a 9/16" socket wrench on the flywheel nut to keep the crankshaft from moving. Figure 54.
- NOTE:** Place the socket handle forward as shown in Figure 54.
5. Remove the clutch with a 3/4" socket or end wrench in a *clockwise* direction. Figure 55.

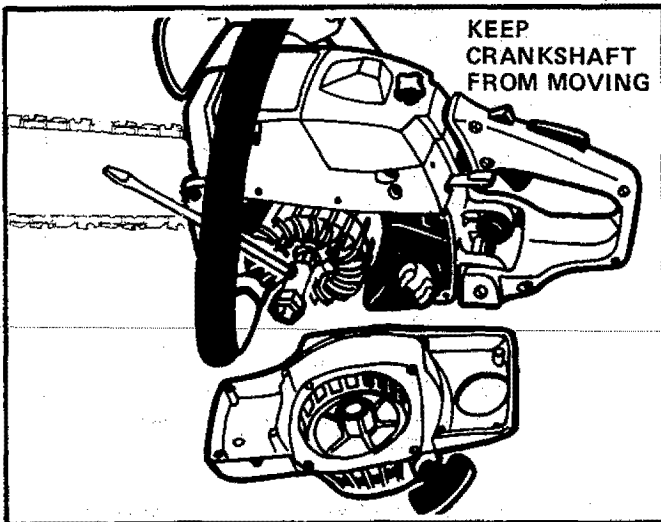

Figure 54

CAUTION: Do not remove the clutch with a punch or a power tool to avoid clutch damage or breakage.

6. Remove worn sprocket and replace.
7. Install clutch in a *counterclockwise* direction. Figure 55.
8. Hold flywheel by hand and torque clutch to 22 ft. pounds.

NOTE: Do not hold a wrench on the flywheel nut when replacing the clutch. This could loosen the flywheel nut.

9. Reinstall fan housing, bar chain and bar clamp.

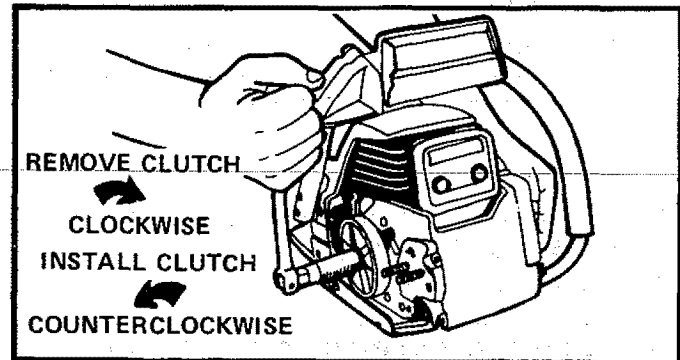

Figure 55

E. CARBURETOR ADJUSTMENTS

- The carburetor has been adjusted at the factory for sea level conditions. Adjustment may become necessary if the unit is used at significantly higher altitudes or if you notice any of the following conditions:
 - Chain moves with the engine at idle speed.
 - Loss of cutting power which is not corrected by air filter or muffler screen cleaning.
 - Engine dies or hesitates when it should accelerate.
- Permanent damage will occur to the engine if incorrect carburetor adjustments are made. To make the adjustment, follow the procedure below very carefully.

- f. Turn the **Low Speed Mixture Screw** and the **High Speed Mixture Screw** one full turn counterclockwise ←

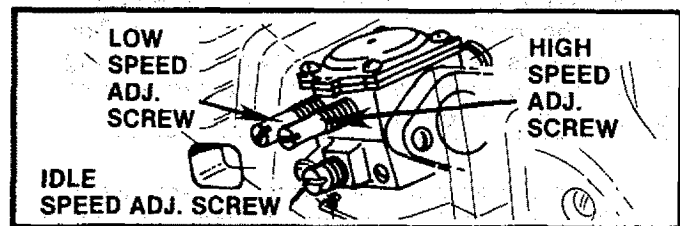

Figure 56

WARNING!
The chain may be moving during this procedure. Wear your protective gear and observe all of the safety precautions.

1. PREPARATION

- a. Stop engine.
- b. Use a fresh fuel mixture with proper gasoline/oil ratio.
- c. Place the saw on a solid, flat surface and make sure the chain will not contact any object.
- d. Locate the three (3) Carburetor adjusting screws located on the fan housing side of the saw. Figure 56.
- e. Turn the **Low Speed Mixture Screw** and the **High Speed Mixture Screw** clockwise → just until they stop. *Do not turn the screws until they are tight as you may damage the needle seats.*

2. IDLE SPEED ADJUSTMENT—I

- a. Start the engine and allow to idle.
- b. Adjust if the engine dies or stops by turning the **Idle Speed Screw** 1/2 turn clockwise →

NOTE: To increase idle speed, turn the Idle Speed Screw clockwise →. To decrease idle speed, turn the Idle Speed Screw counterclockwise ←.

- c. Run the engine for a few minutes to bring it up to operating temperature.

NOTE: The engine must be at operating temperature for proper adjustments to be made.

3. LOW SPEED MIXTURE ADJUSTMENT

- a. Turn the **Low Speed Mixture Screw** slowly clockwise → until the RPM starts to drop. Note the position.
- b. Turn the **Low Speed Mixture Screw** counterclockwise ← until the RPM speeds up and starts to drop again. Note the position.
- c. Set the **Low Speed Mixture Screw** at the mid-point between the two positions.

4. IDLE SPEED ADJUSTMENT—II

- Allow engine to idle.
- Adjust if the chain is turning by turning the **Idle Speed Screw** counterclockwise ←.
- Squeeze the throttle trigger; The saw should accelerate without hesitating.
NOTE: It may be necessary to recheck the low speed mixture setting after the idle speed has been reduced by repeating "Low Speed Mixture Adjustment" as in step 3 above.

5. HIGH SPEED MIXTURE ADJUSTMENT

- Make a test cut.
- Adjust if the saw smokes or seems to have low power in the test cut by turning the **High Speed Mixture Screw** 1/16th of a turn clockwise →.
- Repeat test cut.
- Repeat adjustment until the saw runs smoothly.

CAUTION: Never set the High Speed Mixture Screw less than 7/8 turn open. This is too lean a setting and will ruin your engine.

6. IDLE SPEED ADJUSTMENT—III

Recheck for proper idle mixture setting.

NOTE: It may be necessary to repeat Idle Speed Adjustment-I and Low Speed Mixture, Adjustment.

7. CHECK ACCELERATION

Adjust if there is a slight hesitation, by turning the **Low Speed Mixture Screw** 1/16 of a turn at a time counterclockwise ← until you have smooth acceleration.

NOTE: Check to be sure the chain is not turning when engine is idling. If chain moves at idle speed, repeat Idle Speed Adjustment-II.

F. AIR FILTER

- A dirty air filter:
 - reduces cutting power
 - increases fuel consumption
- Clean the Air Filter:
 - frequently, especially under very dusty conditions.
 - always after 10 tanks of fuel mixture or 5 hours of operation whichever is less.

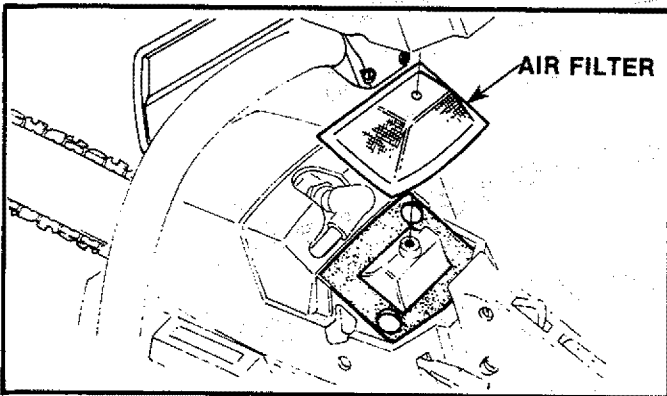

Figure 57

CAUTION: Never operate the unit without the air filter in place to avoid engine damage.

Items Required: soft bristled brush, such as a paint brush.

- Clean off the carburetor cover and the area around it.
- Close choke to prevent dirt from entering the carburetor.
- Remove the carburetor cover. Figure 57.
- Remove the air filter carefully.
- Soak the filter in soap and water.

CAUTION: Do not use gasoline or other flammable liquid to clean the filter to avoid creating a fire hazard.

- Brush away all dust and debris from the filter.
- Allow filter to dry.
- Brush away all debris from surfaces which were covered by the carburetor cover.
- Replace filter and carburetor cover.

G. COUNTER-VIBE® VIBRATION SYSTEM

This saw is equipped with a counter vibration system consisting of 5 isolator mounts. Figure 58. The Isolator Mounts protect the user from engine, bar, and chain vibration similar to the way shock absorbers on a car protect from jolts and bumps in the road.

- Check isolators each time the saw is used.
- Replace isolators when:
 - vibration increases
 - mounts develop an out of round or swollen shape usually caused from exposure to gasoline and oil for long periods of time.
- Replace all five isolators when a failure to one occurs.

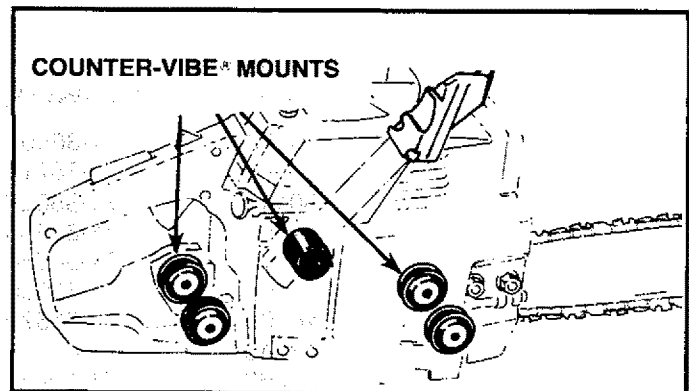

Figure 58

H. STORAGE

When your saw is to be stored for over 30 days always:

1. Drain fuel tank in a safe manner (see Important Points, page 9.)
2. Start Engine and allow to run at an idle speed until the engine stops.

NOTE: This will remove most of the fuel from the fuel system.

CAUTION: Wear protective gloves when handling the chain. The chain is sharp and can cut you even when it is not moving.

3. Drain oil tank.
4. Remove, clean, and dry the bar and chain.
5. Store the chain in a container filled with oil to prevent rust.
6. Apply a coating of oil to the entire surface of the bar and wrap it in heavy paper, cloth or plastic.
7. Clean the outside surfaces of the engine.
8. Store the saw in a dry place, out of the reach of children and away from where fuel vapors can reach open flames from hot water heaters, furnaces, etc.

I. MAINTENANCE ACCESSORIES

Available from your nearest Sears Store, Catalog Sales Office, or Service Center, but not furnished with your saw.

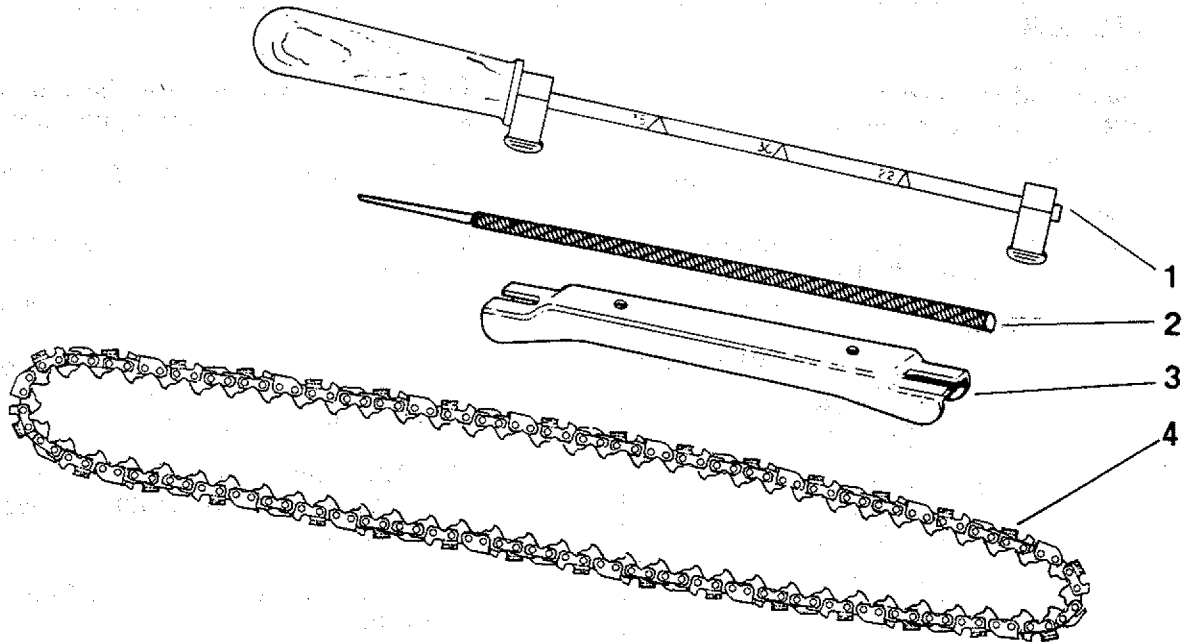

Key No.	Part No.	Catalog No.	Description
1	55046	71-36565	File Guide
2	—	71-36524	File-5/32" dia.-Twin Pack
		71-36526	File-7/32" dia.-Twin Pack
3	—	71-36557	Depth Gauge Tool

Part No.	Catalog No.	Description
30073	71-36407	Spark Plug-Champion CJ-8Y
—	71-36711	Replacement Recoil Cord
30114	71-36627	Carrying Case
—	71-36555	2-Cycle Engine Oil
—	71-36554	Bar and Chain Lubricant (gallon size)
—	71-36556	Bar and Chain Lubricant (quart size)
44209	71-36370	Lo-Kick® Guide Bar - 18" - 358.356100
44246	—	Lo-Kick® Guide Bar - 20" - 358.356090
51262	71-36867	Xtra GUARD® Chain - Oregon® (72SG-70) - 358.356090 (requires 7/32" dia. file)
51241	71-3639	Power Sharp® Chain - Oregon® (76 TS-66) - 358.356100 (includes Stone Cartridge Assy.)

J. TROUBLE SHOOTING CHART

TROUBLE	CAUSE	REMEDY
ENGINE WILL NOT START	<ol style="list-style-type: none"> 1. Ignition Switch off. 2. Fuel tank empty. 3. Spark Plug not firing. 4. Fuel not reaching carburetor. 5. Engine flooded. 6. Compression low. 	<ol style="list-style-type: none"> 1. Move switch to "Start". 2. Fill tank with correct fuel mixture, page 8. 3. Install new plug, page 20. 4. Check for dirty fuel filter; clean. Check for kinked or split fuel line; repair or replace. 5. See Starting Instructions, page 10. 6. Contact Sears Service Center.
ENGINE WILL NOT IDLE PROPERLY	<ol style="list-style-type: none"> 1. Idling speed set too low. 2. Idle speed set too high. 3. Low speed screw requires adjustment. 4. Crankshaft seals worn. 5. Compression low. 	<ol style="list-style-type: none"> 1. Adjust idle speed screw clockwise to increase speed, page 22. 2. Adjust idle speed screw counterclockwise to reduce speed, page 22. 3. See Carburetor Adjustments, page 22. 4. Replace seals or contact Sears Service Center. 5. Contact Sears Service Center.
ENGINE WILL NOT ACCELERATE, LACKS POWER OR DIES IN THE CUT	<ol style="list-style-type: none"> 1. Carburetor requires adjustment. 2. Air filter dirty. 3. Spark Plug fouled, page 19. 4. Carbon build-up. 5. Low Compression. 	<ol style="list-style-type: none"> 1. See Carburetor Adjustments, page 22. 2. Clean or replace air filter, page 23. 3. Clean or replace Spark Plug and regap, page 20. 4. Clean exhaust system including spark arrestor, page 19. 5. Contact Sears Service Center.
ENGINE SMOKES EXCESSIVELY	<ol style="list-style-type: none"> 1. Choke partially on. 2. High speed needle requires adjustment. 3. Air filter dirty. 4. Oil rich fuel mixture. 5. Crankcase leak. 	<ol style="list-style-type: none"> 1. Push Choke in. 2. See Carburetor Adjustments, page 22. 3. Clean or replace air filter, page 23. 4. Empty fuel tank and refill with correct fuel mixture, page 8. 5. Contact Sears Service Center.
ENGINE RUNS HOT	<ol style="list-style-type: none"> 1. Fuel Mixture Incorrect. 2. Spark Plug Incorrect. 3. Carbon build-up. 4. High Speed Mixture set too low. 	<ol style="list-style-type: none"> 1. See Engine Fuel Mixture, page 8. 2. Replace with correct plug, page 20. 3. Clean exhaust systems including spark arrestor, page 19. 4. See Carburetor Adjustments, page 22.
OIL INADEQUATE FOR BAR AND CHAIN LUBRICATION	<ol style="list-style-type: none"> 1. Oil tank empty. 2. Oil pump or oil filter clogged. 3. Guide bar oil hole blocked. 	<ol style="list-style-type: none"> 1. Fill oil tank, page 9. 2. Contact Sears Service Center. 3. Remove bar and clean, page 19.
CHAIN MOVES AT IDLE SPEED	<ol style="list-style-type: none"> 1. Carburetor requires adjustment. 2. Clutch requires repair. 	<ol style="list-style-type: none"> 1. See Carburetor Adjustments, page 22. 2. Contact Sears Service Center.
CHAIN DOES NOT MOVE WHEN ENGINE IS ACCELERATED	<ol style="list-style-type: none"> 1. Chain tension too tight. 2. Carburetor requires adjustment. 3. Guide bar rails pinched. 4. Clutch slipping. 	<ol style="list-style-type: none"> 1. See Chain Tension, page 8. 2. See Carburetor Adjustments, page 22. 3. Repair or replace, page 7 & 19. 4. Contact Sears Service Center.
CHAIN CLATTERS OR CUTS ROUGHLY	<ol style="list-style-type: none"> 1. Chain tension incorrect. 2. Cutters dull, improperly sharpened; depth gauges too high. 3. Sprocket worn. 4. Chain wear due to contact with dirt, sand or frozen wood. 5. Cutters damaged after striking foreign material. 	<ol style="list-style-type: none"> 1. See Chain Tension, page 8. 2. See Chain Sharpening Instructions, page 18 (page 12-13 for Power Sharp*). 3. Replace, page 21. 4. Resharpen or replace Chain, page 18-19 (page 12-13 for Power Sharp*). 5. Contact Sears Service Center. Sharpen all cutters evenly and uniformly or replace chain. See chain sharpening instructions, page 18-19 (page 12-13 for Power Sharp*).
CHAIN STOPS WITHIN THE CUT	<ol style="list-style-type: none"> 1. Chain cutter tops not filed flat. 2. Guide bar burred or bent; rails uneven. 3. Clutch slipping. 	<ol style="list-style-type: none"> 1. See Chain Sharpening instructions, page 18-19 (page 12-13 for Power Sharp*). 2. Repair or replace guide bar, page 7 & 19. 3. Contact Sears Service Center.
CHAIN CUTS AT AN ANGLE	<ol style="list-style-type: none"> 1. Cutters damaged on one side. 2. Chain dull on one side. 3. Guide bar bent, or worn. 	<ol style="list-style-type: none"> 1. Resharpen until all cutters have equal angles and lengths, page 18-19 (page 12-13 for Power Sharp*). 2. Resharpen until all cutters have equal angles and lengths, page 18-19 (page 12-13 for Power Sharp*). 3. Replace guide bar, page 7 & 19.

MAINTENANCE CHART

		before starting work	after finishing work or daily	after each refueling stop	weekly	monthly	if faulty	if damaged	as required	see page:
Complete machine	Visual inspection (condition, leaks)	x		x						
	clean		x							
Throttle trigger, safety throttle lock, stop switch	Check operation	x		x						10
Filter in fuel tank	Clean Felt					x				
	Replace felt							x		
Fuel tank	Clean					x				
Chain oil tank	Clean					x				
Chain lubrication	Check	x								9
Saw chain	Inspect, also check sharpness	x		x						
	Check chain tension	x		x						8
	Sharpen								x	18
Guide bar	Inspect (wear, damage)	x								19
	Clean				x		x			19
	Lubricate sprocket nose		x							19
	Deburr				x					19
	Replace							x	x	7
Chain sprocket	Check				x					21
Air filter	Clean	x					x			23
	Replace							x		23
Cooling inlets	Clean		x							19
Cylinder fins	Clean					x				19
Carburetor	Check idle adjustment – chain must not turn	x		x						22
	Readjust idle								x	22
Spark plug	Readjust electrode gap						x			20
All accessible screws and nuts (not adjusting screws)	Retighten	x								
Vibration mounts	Inspect				x					23
	To be replaced by a qualified Service Dealer							x		
Spark arrestor screen	Inspect	x								19
	Clean or replace							x		19

NOTES

SEARS CHAIN SAW PARTS LIST

MODELS	358.356090	358.356100
	3.7/20"	3.7/18" PS

Figure 1

Key No.	Part No.	Qty.	Description	Key No.	Part No.	Qty.	Description
1	39095	1	Flywheel Assembly (incl. # 2)	37	15365	1	Screw - Fan Housing (Lower Front)
2	23817	2	Spring - Starter Dog	38	30073	1	Spark Plug (CJ-8Y)
3	STD522525	2	Screw - Muffler Cover	39	15195	1	Clip - High Tension Lead Cylinder
4	15434	2	Screw - Spur	40	25933	2	Piston Ring
5	24476	1	Spur	41	24492	1	Crankshaft and Rod Assembly
6	1626	1	Washer - Flywheel	42	1624	4	Screw - Cylinder
7	1722	1	Flywheel Nut	43	39096	1	High Tension Lead
8	15468	1	Screw - Starter Pulley	44	10626	1	Piston Assembly Kit (incl. #40 and pin)
9	15123	1	Washer - Starter Pulley Retainer	45	STD580008	1	Key - Flywheel
10	STD600603	2	Screw Disc Mounting	46	15366	2	Screw - Fan Housing (Rear)
11	30054	—	Sealant Crankcase 3 oz. Optional	47	39097	1	Boot - Spark Plug
12	42053	1	Disc - Recoil Spring Outer	48	39071	1	Connector - Spark Plug
13	24329	1	Bushing - Recoil Spring	49	39102	1	High Tension Lead Assembly (Incl. #43, 47, & 48)
14	42051	1	Spring - Starter Recoil	50	10444	1	Oil Cap Assembly (Incl. #51)
15	42066	1	Disc - Recoil Spring Inner	51	19119	1	"O" Ring - Oil Cap
16	15364	1	Screw - Fan Housing (Top Front)	52	24334	1	Clamp - High Tension Lead (Crankcase)
17	10720	1	Fan Housing Assembly	53	39093	1	Ignition Module (incl. #49 & 59)
18	24392	1	Shield Muffler	54	15425	2	Screw - Module Mounting
19	24391	1	Muffler Cover	55	23661	2	Clamp - Lead
20	STD522505	2	Screw - Muffler Body/Cylinder	56	STD600603	2	Screw - Lead Clamp
21	24385	1	Screen - Spark Arrestor	57	STD511007	9	Screw - Crankcase
22	24384	2	Diffuser - Muffler	58	23732	1	Switch - Toggle
23	19097	2	Seal - Crankshaft	59	39099	1	Switch Lead
24	STD600603	2	Screw - Air - Baffle	60	23575	1	Ignition Switch Nut
25	24232	1	Baffle - Air	61	24858	1	Plate - Start/Stop
26	28487	1	Pulley - Starter	62	31107	1	Scrench
27	24388	1	Back Plate - Muffler	—	66371	1	Operator's Manual (not shown)
28	24387	1	Muffler Body	Decal A	26468	1	Decal Fan Housing
29	32051	2	Bearings - Crankshaft				
30	15354	2	Thrust Washers - Crankshaft				
31	30039	2	Kit - Bar Stud Replacement				
32	42056	1	Handle - Starter Rope				
33	42052	1	Rope - Starter				
34	12067	1	Cylinder				
35	19098	1	Gasket - Cylinder				
36	—	—	Crankcase Assembly Right & Left Half (incl. #23, 29, 31 & 50 on Fig. 1; also includes from Fig. 3, #22, 30, 43 & one of 37.)				
	10696	1	358.356090				
	10699	1	358.356100				



SEARS CHAIN SAW PARTS LIST

MODELS

358.356090
3.7/20"

358.356100
3.7/18" PS

Figure 2

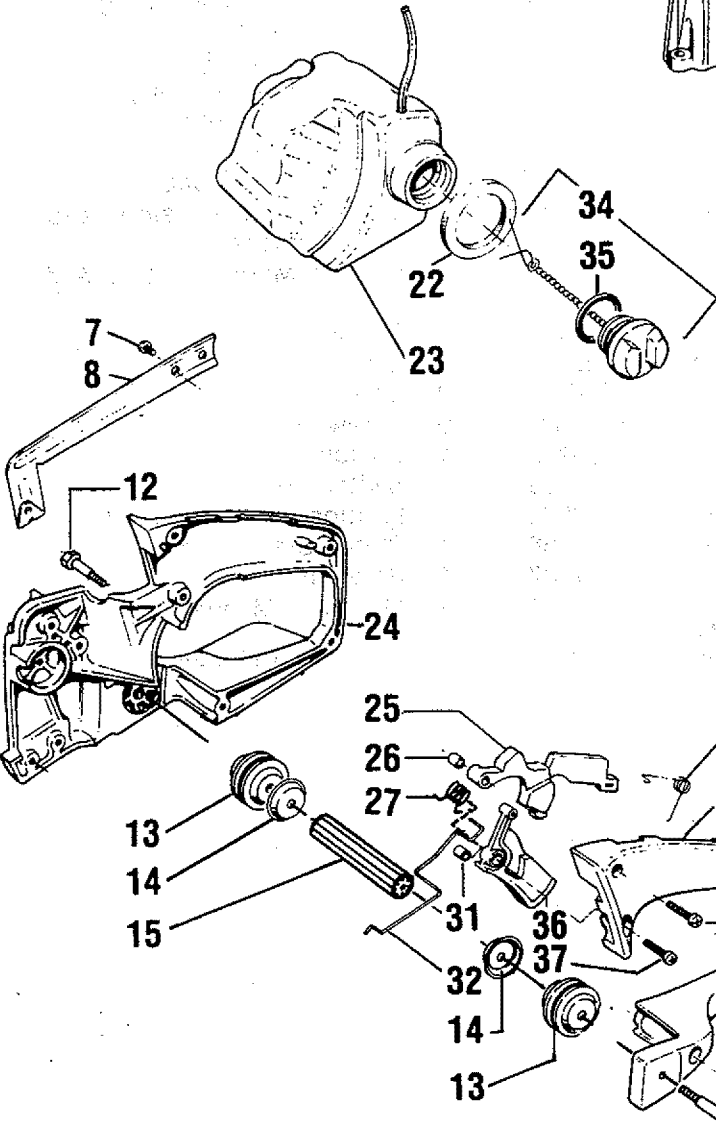
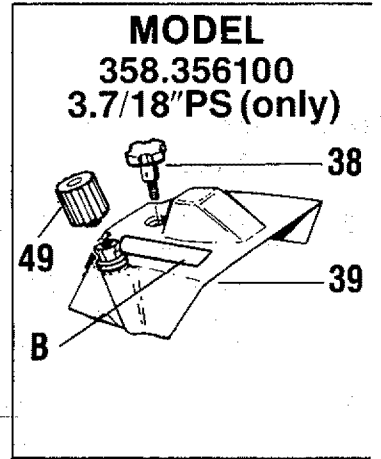
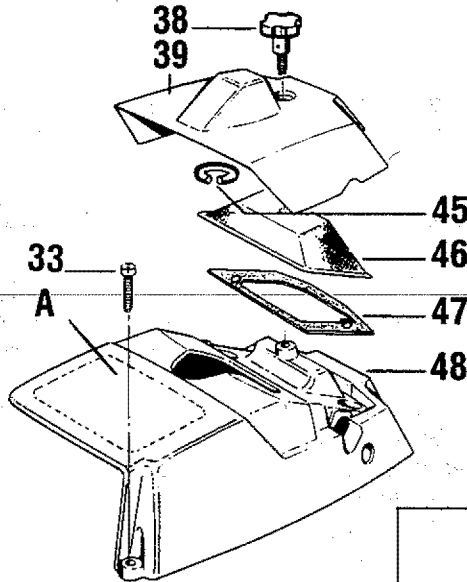
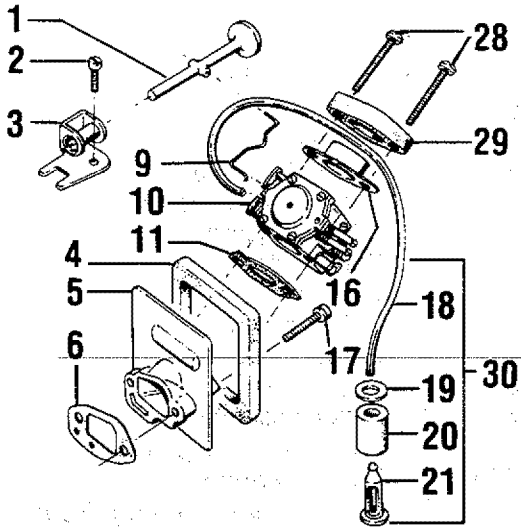

CARBURETOR ASSEMBLY
PART NO. 35094

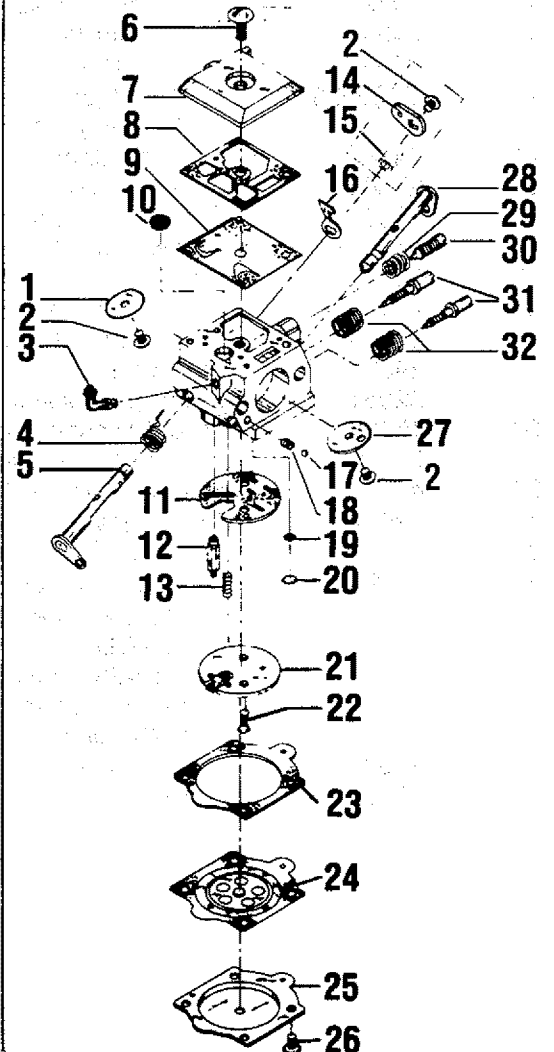

SEARS CHAIN SAW PARTS LIST

MODELS 358.356090 358.356100
3.7/20" 3.7/18" PS

Figure 3

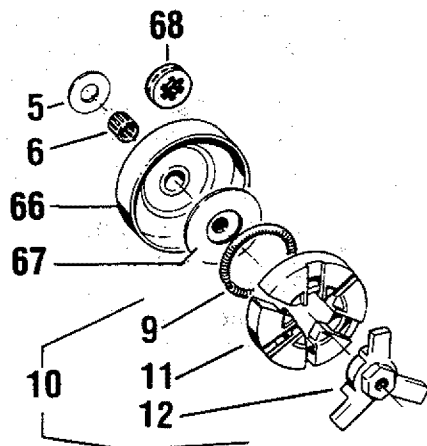
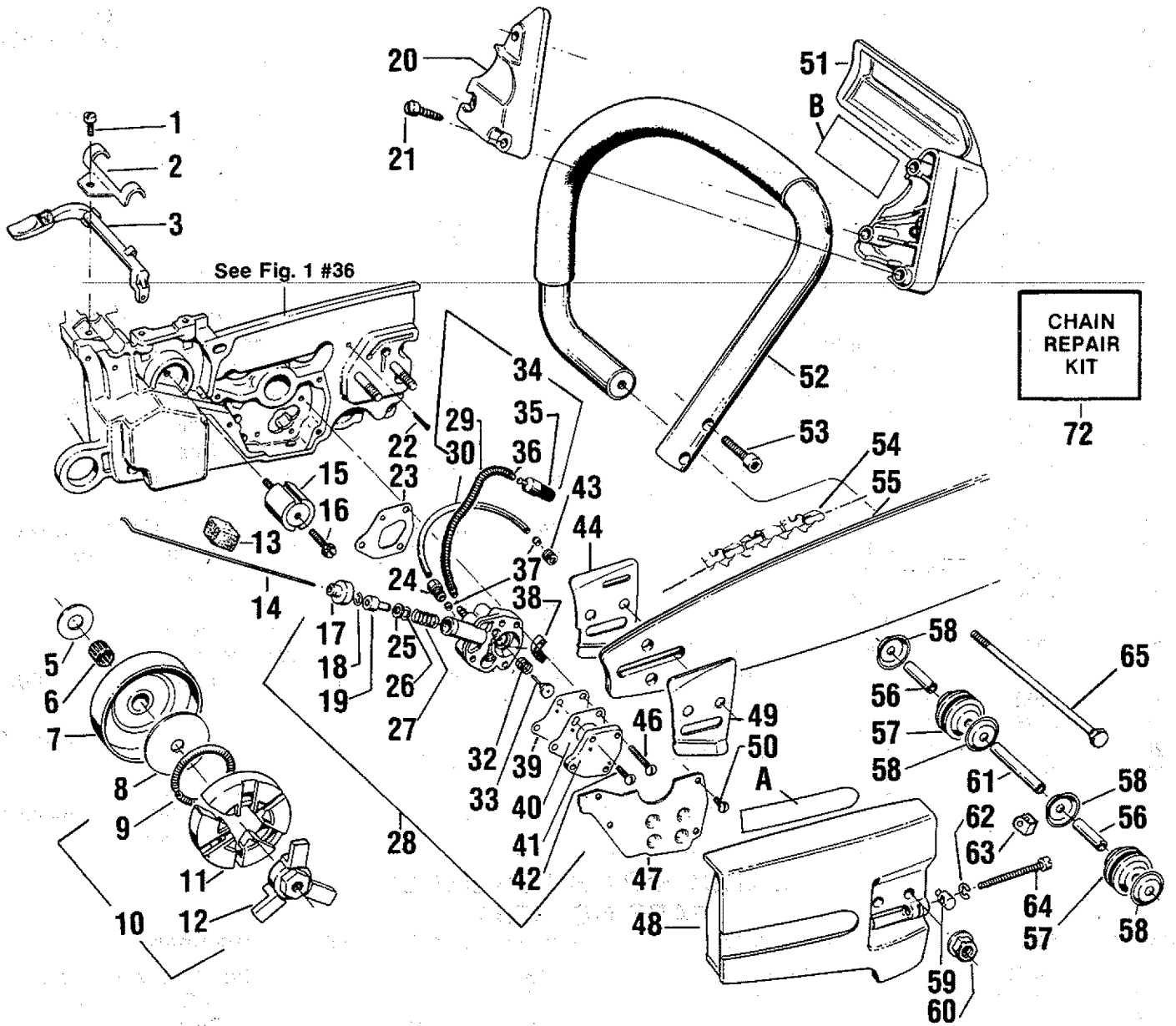

MODEL
358.356100
3.7/18" PS
(only)

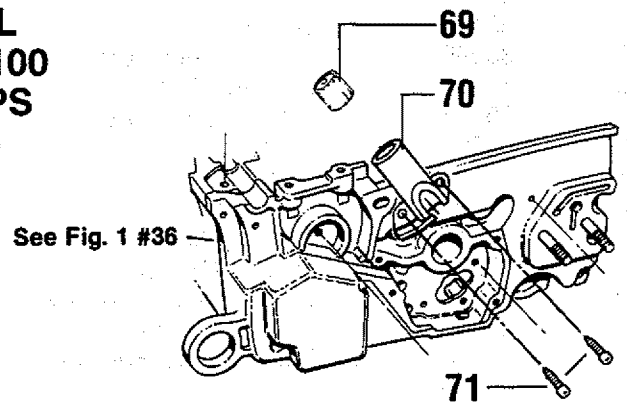

SEARS CHAIN SAW PARTS LIST
MODELS 358.356090 358.356100
3.7/20" 3.7/18" PS

Figure 3

Key No.	Part No.	Qty.	Description	Key No.	Part No.	Qty.	Description
1	STD511003	1	Screw-Bracket to Crankcase	40	19102	1	Gasket - Cover to Body
2	24351	1	Bracket-Lever to Crankcase	41	25987	1	Cover - Pump
3	24348	1	Lever - Manual Oiler	42	15297	1	Screw-Oil Pump Cover
5	15357	1	Thrust Washer	43	15422	1	Tubing Nut - Crankcase
6	32049	1	Bearing - Clutch	44	25925	1	Guide Bar Plate - Inner
7	—	1	Drum & Sprocket Assembly	46	STD510810	3	Screw - Pump to Crankcase
	48069		358.356090	47	24399	1	Cover Plate - Oiler
	48071		358.356100	48	—	—	Bar Clamp Assembly
8	24465	1	Plate - Clutch (358.356090)		10727	1	(incl. #59, 62, 63 & 64) 358.356090
					10741	1	358.356100
9	24353	1	Spring - Clutch	49	25924	1	Guide Bar Plate - Outer
10	—	—	Clutch Ass'y. (Incl. #9, 11 & 12)	50	STD600603	4	Screw Oiler Cover Plate
	10291	1	358.356090	51	24466	1	Handguard
	10466	1	358.356100	52	22258	1	Handle Bar Assembly
11	24352	3	Shoe Clutch	53	STD522510	2	Screw - Handlebar/ Rear Handle
12	—	—	Spider - Clutch	54	—	—	Chain
	26246	1	358.356090		51262	1	358.356090
	25428	1	358.356100		51241	1	358.356100 - Incl. #70
13	23373	1	Boot - Oiler Rod	55	44209	1	Bar - 18" SN
14	24347	1	Rod - Manual Oiler		44246	1	Bar - 20" SN
15	24225	1	Isolator - Crankcase Side	56	15362	2	Isolator Mount Spacer Front Handlebar
16	15406	1	Screw-Side Isolator/ Crankcase	57	24373	2	Isolator - Front Handlebar
17	23356	1	Cap - Oil Pump	58	24376	4	Isolator Cups - Front Handlebar
18	STD583037	1	Retainer Ring - Oil Pump	59	25044	1	Pin - Bar Adj.
19	23357	1	Piunger - Oil Pump	60	15445	2	Flange Nut - Bar Mounting
20	24467	1	Cap - Handguard	61	15361	1	Spacer - Isolator
21	15509	3	Screw/Handguard	62	STD581018	1	E Ring - Adj. Screw
22	STD560907	1	Cotter Pin - Vent	63	25414	1	U-Clip - Bar Clamp
23	19103	1	Gasket Body to Crankcase	64	15385	1	Screw - Bar Adj.
24	2615	1	Tubing Nut - Oiler	65	15549	1	Screw - Isolator Mount to Handlebar
25	19029	1	Quad Ring - Oil Pump	66	48071	1	Clutch Drum & Adaptor Ass'y. - (7 Spline 3/8P) - (358.356100)
26	15418	1	Washer - Oiler	67	15484	1	Plate Clutch (358.356100)
27	23358	1	Spring - Oil Pump	68	4746	1	Floating Rim - Sprocket (3/8P - 7 Tooth) - (358.356100)
28	10638	1	Oil Pump Assembly- Auto/Manual (Incl. #17, 18, 19, 24, 25, 26, 27, 30, 32, 33, 34, 38, 39, 40, 41, 42 & one of 37)	69	25421	1	Slide Button
29	24677	1	Spring - Oil Line Protector	70	69099	1	Stone & Carrier Ass'y. (Incl. #69) - (358.356100)
30	21038	1	Discharge Oil Line	71	STD511005	2	Screw - (358.356100)
32	23699	1	Spring - Diaphragm	72	52079	—	Chain Repair Kit (358.356090 only) optional
33	22197	1	Button and Pintle Assembly				
34	10289	1	Oil Line Pick-Up Assembly (Incl. #29, 35 and 36)	Decal			
35	24676	1	Weight - Oil Pick-Up Line	A	26468	1	Decal Strip - Bar Clamp
36	21031	1	Oil Line	B	25631	1	Decal Handguard
37	2464	2	Sleeve - 1/8 Tubing	—	26550	1	Decal Chain Tensioning- Not Shown
38	24691	1	Filter - Oil Pump Vent	—	26545	1	Decal - Warranty - Guide Bar - not shown
39	24345	1	Diaphragm - Oil Pump				

NOTES

QUICK REFERENCE PAGE

**Read and follow all Safety Rules, Precautions and Operating Instructions.
Failure to do so can result in serious personal injury.**

	page
SAFETY RULES AND PRECAUTIONS	3-4
PREPARATION	3
1. Wear personal protective gear — gloves; safety footwear; snug fitting clothing; and eye, hearing and head protection.	
2. Check for worn, loose, or damaged parts and repair or replace as necessary.	
3. Check the chain for sharpness and tension.	
4. Keep children, bystanders and pets out of the work area.	
5. Plan your sawing operation carefully in advance.	
FUEL AND OIL	8
1. Eliminate all sources of sparks or flame where fuel is mixed, poured, or stored.	
2. Use 1 part air-cooled, 2-cycle engine oil to 16 parts regular gasoline.	
3. Use gasoline not over 2 months old.	
4. Mix, store and pour fuel in an approved, marked container and in a well-ventilated area.	
5. Move a minimum of 10 feet away from fuel and fueling site before starting engine.	
6. Fill the oil tank each time the fuel tank is refueled.	
STARTING THE ENGINE	10
1. Hold saw firmly with the saw chain free to turn without making contact with any object.	
2. Push saw away from you with your right hand while pulling the starter rope with your left hand.	
3. Use no more than 15-18 inches of rope per pull.	
4. Pull rope no more than 5-6 times.	
5. Release the trigger after engine starts allowing engine to idle.	
OPERATING THE UNIT	14
1. Cut wood only.	
2. Accelerate the engine to full throttle before entering the cut.	
3. Begin cutting with the saw frame up against the log.	
4. Cut only at full throttle.	
5. Release the trigger as soon as the cut is completed.	
6. Stop the engine before setting the saw down after cutting.	
MAINTENANCE	18
1. Adjust or have the carburetor adjusted if the chain moves when the engine idles.	
2. Disconnect spark plug before performing maintenance except for carburetor adjustment.	
3. Check the guide bar for wear each time the chain is sharpened.	
4. Clean the air filter frequently and always after 10 tanks of fuel mixture or 5 hours of operation, whichever is less.	
5. Clean igniton, cooling and exhaust systems at least once for each 25-30 hours of operation.	
6. Take the saw to your Sears Service Center for full clutch inspection after each 100 hours of operation.	
7. Drain fuel tank in a safe manner after each use.	
8. Store saw in a dry place out of the reach of children.	

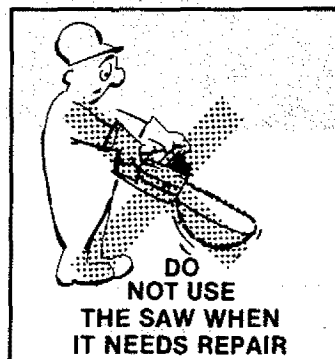
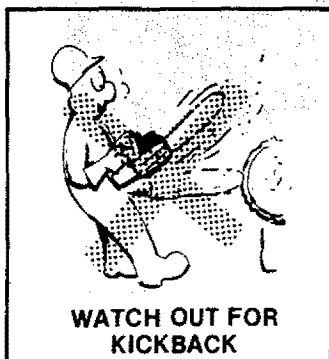

Sears

MODEL NO.

358.356090-3.7/20"
358.356100-3.7/18" PS

How to Order Repair Parts

SEARS SERVICE

The Model Number will be found under the handle with the Serial Number. Always mention the Model Number when requesting service or repair parts for your Chain Saw.

All parts listed herein may be ordered from any Sears Service Center and most Sears Stores.

WHEN ORDERING REPAIR PARTS, ALWAYS GIVE THE FOLLOWING INFORMATION AS SHOWN IN THIS LIST.

1. The PART NUMBER
2. The MODEL NUMBER
358.356090-3.7/20"
358.356100-3.7/18" PS
3. The PART DESCRIPTION
4. The NAME OF ITEM —
Chain Saw

If the parts you need are not stocked locally, your order will be electronically transmitted to a Sears Repair Parts Distribution center for expedited handling.

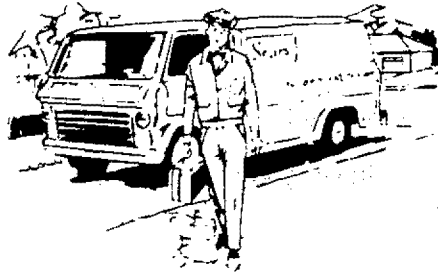

When you buy merchandise from Sears you get an extra something that nobody else can offer ... Sears Service.

Across town or across the country, Sears Service follows you, providing trustworthy, competent service technicians using only Sears specified factory parts.

TOTAL-TESTED
for Quality and Dependability

Chain Saws bearing this label undergo our toughest testing program ever

- ✓ Parts are inspected to meet rigid quality control standards
- ✓ Each saw is started and tuned electronically before it's packed to insure dependability
- ✓ Another quality check: saws are randomly selected and re-inspected
- ✓ Professional woodcutters performance-test our saws under actual working conditions

Sears, Roebuck and Co., Chicago, Ill. 60684 U.S.A.