

Use & Care Guide

Manual de Uso y Cuidado

Guide d'utilisation et d'entretien

English / Español / Français

Models/Modelos/Modèles: 253.7034*, 7041*, 7042*, 7044*

Kenmore®

French Door Bottom Freezer

Congelador Inferior de Puerta Doble
La Porte-fenêtre Congélateur Inférieur

* = Color number, número de color, le numéro de couleur

P/N A05963501 (1611)

Sears Brands Management Corporation

Hoffman Estates, IL 60179 U.S.A.

www.kenmore.com

www.sears.com

Sears Canada Inc.

Toronto, Ontario, Canada M5B 2C3

www.sears.ca



Record Model/Serial Numbers

Please read and save these instructions.

This Use & Care Guide provides specific operating instructions for your model. Use your unit only as instructed in this guide. These instructions are not meant to cover every possible condition and situation that may occur. Common sense and caution must be practiced when installing, operating, and maintaining any appliance.

Please record your model and serial numbers below for future reference. This information is found on the serial plate located inside the refrigerator compartment.

Model Number: 253

Serial Number: _____

Purchase Date: _____

IMPORTANT

Use only soap and water to clean serial plate.

Table of Contents

Record Model/Serial Numbers	2
Important Safety Instructions.....	2-4
Warranty Information	5
Master Protection Agreements	6
Features at a Glance	7
Installation	8-10
Door Removal Instructions	11-12
Installing Door Handles	13
Connecting the Water Supply.....	14-15
Controls	16-20
Automatic Ice & Water Dispenser	21-23
Storage Features	24-27
Storing Food and Saving Energy	28
Normal Operating Sounds	29
Changing the Filter	30-31
Care & Cleaning	32-33
Before You Call	34-38

Important Safety Instructions

Safety Precautions

Do not attempt to install or operate your unit until you have read the safety precautions in this manual. Safety items throughout this manual are labeled with a Danger, Warning, or Caution based on the risk type.

Definitions

 This is the safety alert symbol. It is used to alert you to potential personal injury hazards. Obey all safety messages that follow this symbol to avoid possible injury or death.



DANGER

DANGER indicates an imminently hazardous situation which, if not avoided, will result in death or serious injury.



WARNING

WARNING indicates a potentially hazardous situation which, if not avoided, could result in death or serious injury.



CAUTION

CAUTION indicates a potentially hazardous situation which, if not avoided, may result in minor or moderate injury.

IMPORTANT

Indicates installation, operation, or maintenance information which is important but not hazard-related.

Important Safety Instructions



WARNING

Please read all safety instructions before using your new appliance.

For your Safety

DO NOT store or use gasoline, or other flammable liquids in the vicinity of this or any other appliance. Read product labels for warnings regarding flammability and other hazards.

DO NOT operate the refrigerator in the presence of explosive fumes.

Avoid contact with any moving parts of automatic ice maker.

Remove all staples from the carton. Staples can cause severe cuts, and also destroy finishes if they come in contact with other appliances or furniture.

Child Safety

Destroy or recycle the carton, plastic bags, and any exterior wrapping material immediately after the refrigerator is unpacked. Children should never use these items to play. Cartons covered with rugs, bedspreads, plastic sheets or stretch wrap may become airtight chambers, and can quickly cause suffocation.

Proper Disposal of your Refrigerator or Freezer

Risk of child entrapment

Child entrapment and suffocation are not problems of the past. Junked or abandoned refrigerators or freezers are still dangerous – even if they will sit for “just a few days”. If you are getting rid of your old refrigerator or freezer, please follow the instructions below to help prevent accidents.

We strongly encourage responsible appliance recycling/disposal methods. Check with your utility company or visit www.energystar.gov/recycle for more information on recycling your old refrigerator.

Before you throw away your old refrigerator/freezer:

Remove doors.

Leave shelves in place so children may not easily climb inside.

Have refrigerant removed by a qualified service technician.

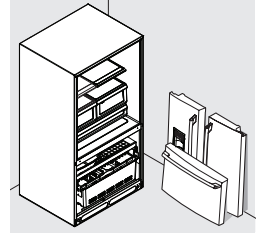

IMPORTANT

CFC/HCFC Disposal

Your old refrigerator may have a cooling system that used CFCs or HCFCs (chlorofluorocarbons or hydrochlorofluorocarbons). CFCs and HCFCs are believed to harm stratospheric ozone if released to the atmosphere. Other refrigerants may also cause harm to the environment if released to the atmosphere.

If you are throwing away your old refrigerator, make sure the refrigerant is removed for proper disposal by a qualified technician. If you intentionally release refrigerant, you may be subject to fines and imprisonment under provisions of environmental legislation.

Important Safety Instructions

Electrical information

The refrigerator must be plugged into its own dedicated 115 Volt, 60 Hz., 15 Amp, AC only electrical outlet. The power cord of the appliance is equipped with a three-prong grounding plug for your protection against electrical shock hazards. It must be plugged directly into a properly grounded three prong receptacle. The receptacle must be installed in accordance with local codes and ordinances. Consult a qualified electrician. Avoid connecting refrigerator to a Ground Fault Interrupter (GFI) circuit. Do not use an extension cord or adapter plug.

If the power cord is damaged, it should be replaced by an authorized service technician to prevent any risk.

Never unplug the refrigerator by pulling on the power cord. Always grip the plug firmly, and pull straight out from the receptacle to prevent damaging the power cord.

Unplug the refrigerator before cleaning and before replacing a light bulb to avoid electrical shock.

Performance may be affected if the voltage varies by 10% or more. Operating the refrigerator with insufficient power can damage the compressor. Such damage is not covered under your warranty.

Do not plug the unit into an electrical outlet controlled by a wall switch or pull cord to prevent the refrigerator from being turned off accidentally.

IMPORTANT

Pressing and holding the On/Off button for three seconds, located on the temperature control panel, will disable your refrigerator's cooling system but does not disconnect the power to the light bulb and other electrical components. To turn off power to your refrigerator you must unplug the power cord from the electrical outlet.

Grounding type wall receptacle

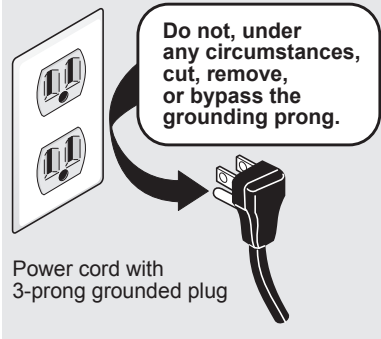

CAUTION

To avoid personal injury or property damage, handle tempered glass shelves carefully. Shelves may break suddenly if nicked, scratched, or exposed to sudden temperature change.

Warranty Information

KENMORE LIMITED WARRANTY

FOR ONE YEAR from the date of sale this appliance is warranted against defects in material or workmanship when it is correctly installed, operated and maintained according to all supplied instructions.

WITH PROOF OF SALE, a defective appliance will receive free repair or replacement at option of seller.

For warranty coverage details to obtain free repair or replacement, visit the web page: www.kenmore.com/warranty

This warranty applies for only 90 DAYS from the sale date in the United States, and is void in Canada, if this appliance is ever used for other than private household purposes.

This warranty covers ONLY defects in material and workmanship, and will NOT pay for:

1. Expendable items that can wear out from normal use, including but not limited to filters, belts, bags or screw-in base light bulbs.
2. A service technician to clean or maintain this appliance, or to instruct the user in correct appliance installation, operation and maintenance.
3. Service calls to correct appliance installation not performed by Sears authorized service agents, or to repair problems with house fuses, circuit breakers, house wiring, and plumbing or gas supply systems resulting from such installation.
4. Damage to or failure of this appliance resulting from installation not performed by Sears authorized service agents, including installation that was not in accord with electrical, gas or plumbing codes.
5. Damage to or failure of this appliance, including discoloration or surface rust, if it is not correctly operated and maintained according to all supplied instructions.
6. Damage to or failure of this appliance, including discoloration or surface rust, resulting from accident, alteration, abuse, misuse or use for other than its intended purpose.
7. Damage to or failure of this appliance, including discoloration or surface rust, caused by the use of detergents, cleaners, chemicals or utensils other than those recommended in all instructions supplied with the product.
8. Damage to or failure of parts or systems resulting from unauthorized modifications made to this appliance.
9. Service to an appliance if the model and serial plate is missing, altered, or cannot easily be determined to have the appropriate certification logo.

Disclaimer of implied warranties; limitation of remedies

Customer's sole and exclusive remedy under this limited warranty shall be product repair or replacement as provided herein. Implied warranties, including warranties of merchantability or fitness for a particular purpose, are limited to one year on the appliance and five years on the sealed system, or the shortest period allowed by law. Seller shall not be liable for incidental or consequential damages. Some states and provinces do not allow the exclusion or limitation of incidental or consequential damages, or limitation on the duration of implied warranties of merchantability or fitness, so these exclusions or limitations may not apply to you.

This warranty applies only while this appliance is used in the United States or Canada*.

This warranty gives you specific legal rights, and you may also have other rights which vary from state to state.

* In-home repair service is not available in all Canadian geographical areas, nor will this warranty cover user or servicer travel and transportation expenses if this product is located in a remote area (as defined by Sears Canada Inc.) where an authorized servicer is not available.

Sears Brands Management Corporation, Hoffman Estates, IL 60179
Sears Canada Inc., Toronto, Ontario, Canada M5B 2C3

Master Protection Agreements

Congratulations on making a smart purchase. Your new Kenmore® product is designed and manufactured for years of dependable operation. But like all products, it may require preventive maintenance or repair from time to time. That's when having a Master Protection Agreement can save you money and aggravation.

The Master Protection Agreement also helps extend the life of your new product. Here's what the Agreement* includes:

- ✓ **Parts and labor** not just for repairing defects, but to help keep products operating properly **under normal use**. Our coverage goes **well beyond the product warranty**. No deductibles, no functional failure excluded from coverage— **real protection**.
- ✓ **Expert service** by a force of more than **10,000 authorized Sears service technicians**, which means someone you can trust will be working on your product.
- ✓ **Unlimited service calls and nationwide service**, as often as you want us, whenever you want us.
- ✓ **“No-lemon” guarantee** – replacement of your covered product if four or more product failures occur within twelve months.
- ✓ **Product replacement** if your covered product can't be fixed.
- ✓ **Annual Preventive Maintenance Check** at your request – no extra charge.
- ✓ **Fast help by phone** – we call it **Rapid Resolution** – phone support from a Sears representative on all products. Think of us as a “talking owner's manual.”
- ✓ **Power surge protection** against electrical damage due to power fluctuations.
- ✓ **\$250 Food Loss Protection** annually for any food spoilage that is the result of mechanical failure of any covered refrigerator or freezer.
- ✓ **Rental reimbursement** if repair of your covered product takes longer than promised.
- ✓ **25% discount** off the regular price of any non-covered repair service and related installed parts.

Once you purchase the Agreement, a simple phone call is all that it takes for you to schedule service. You can call anytime day or night, or schedule a service appointment online.

The Master Protection Agreement is a risk free purchase. If you cancel for any reason during the product warranty period, we will provide a full refund. Or, a prorated refund anytime after the product warranty period expires. Purchase your Master Protection Agreement today!

Some limitations and exclusions apply. For prices and additional information in the U.S.A. call 1-800-827-6655.

*** Coverage in Canada varies on some items. For full details call Sears Canada at 1-800-361-6665.**

Sears Installation Service

For Sears professional installation of home appliances, garage door openers, water heaters, and other major home items, in the U.S.A. call 1-844-553-6667, and in Canada call 1-800-469-4663.

Features At A Glance

*Features may vary according to model

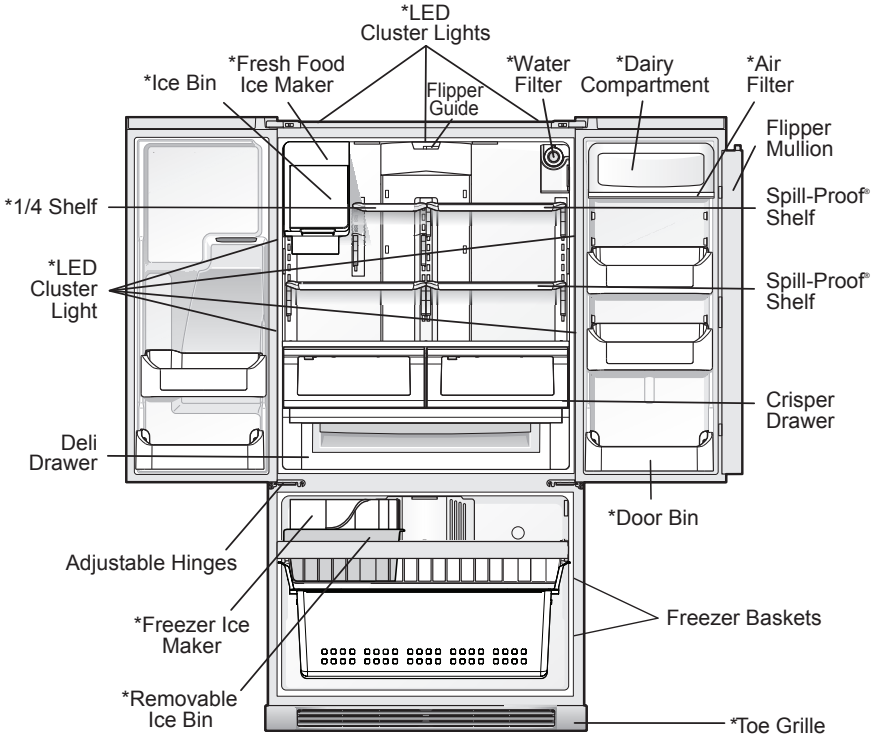

Installation

Tools Necessary:

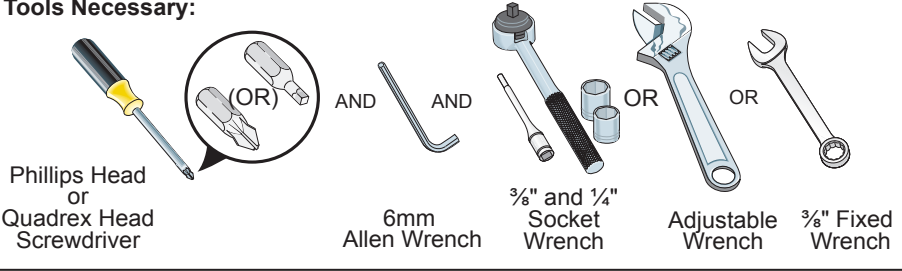

Components Provided:

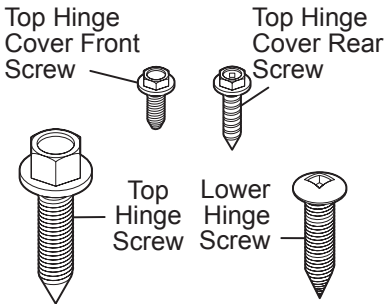

This Use & Care Guide provides general installation and operating instructions for your model. We recommend using a service or kitchen contracting professional to install your refrigerator. Use the refrigerator only as instructed in this Use & Care Guide. Before starting the refrigerator, follow these important first steps.

Location

Choose a place that is near a grounded, non-GFCI, electrical outlet. Do Not use an extension cord or an adapter plug.

If possible, place the refrigerator out of direct sunlight and away from the range, dishwasher, or other heat sources.

The refrigerator must be installed on a floor that is level and strong enough to support a fully loaded refrigerator.

Consider water supply availability for models equipped with an automatic ice maker.



CAUTION

Do Not install the refrigerator where the temperature will drop below 55°F (13°C) or rise above 110°F (43°C). The compressor will not be able to maintain proper temperatures inside the refrigerator.

Do Not block the toe grille on the lower front of your refrigerator. Sufficient air circulation is essential for the proper operation of your refrigerator.

Installation

Allow the following clearances for ease of installation, proper air circulation, and plumbing and electrical connections:

Sides & Top	3/8 inch (9.5 mm)
Back	1 inch (25.4 mm)

NOTE

If your refrigerator is placed with the door hinge side against a wall, you may have to allow additional space so the door can be opened wider.

Door opening

Your refrigerator should be positioned to allow easy access to a counter when removing food. For best use of refrigerator drawers and freezer baskets, the refrigerator should be in a position where both can be fully opened.

Installation



CAUTION

Do Not loosen or remove these 3 hex screws.

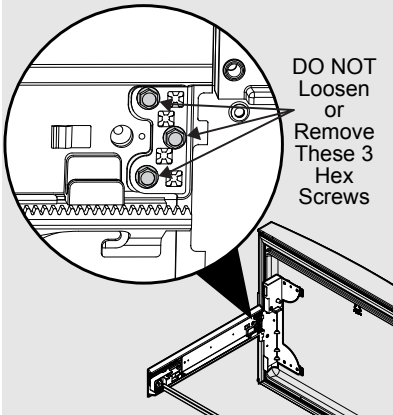

Cabinet Leveling & Refrigerator Door Alignment (if necessary)

Guidelines for final positioning of your refrigerator:

All four corners of the cabinet must rest firmly on the floor.

The front should be slightly elevated to ensure that doors close and seal properly.

Doors should align with each other and be level.

Most of these conditions can be met by raising or lowering the adjustable front rollers.

To level the cabinet using the front rollers:

- 1 Slightly open freezer drawer if the toe grille is installed. Lift the toe grille and gently pull forward.
- 2 Make initial cabinet adjustments by using the front roller height adjusting screws. Use a 3/8 inch socket wrench to turn the adjustment screws (1 per side).

To raise: turn adjustment screw clockwise.

To lower: turn adjustment screw counterclockwise.

- 3 Ensure both doors are bind-free with their seals touching the cabinet on all four sides and that cabinet is stable.
- 4 After unit is leveled, lower anti-tip leg using a 3/8 inch socket wrench until it firmly contacts the floor.

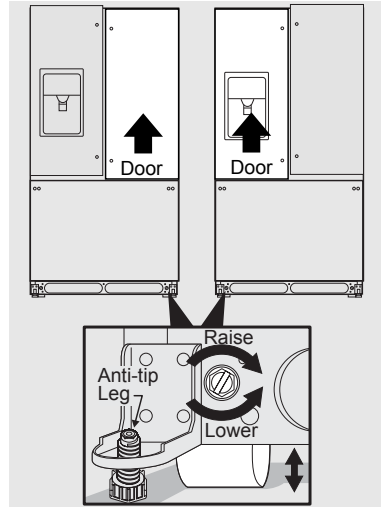

- 5 Install the toe grille by fitting into place.

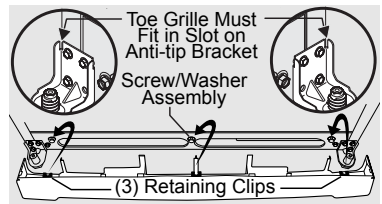

Installation

To make final door height adjustments:

1. Open freezer drawer to make lower hinge visible.
2. Insert 6mm Allen wrench into the shaft of the lower hinge.
3. Adjust the height by turning clockwise or counterclockwise. Turning clockwise will lower the door. Turning counterclockwise will raise the door. Default setting is to the lowest height when you receive your appliance.

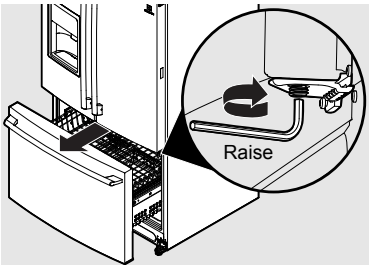

To adjust the flipper mullion:

1. Loosen the screw located on the flipper mullion hinge.

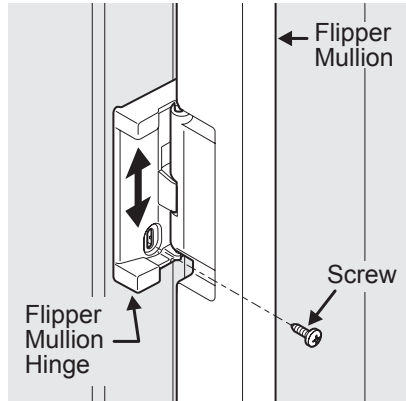

Adjusting Flipper Mullion Screw

2. Adjust flipper mullion height. For proper connection with the flipper mullion guide, there should be a separation about the thickness of a coin (0.060 inches, or 1.5 mm) between the guide and flipper mullion.

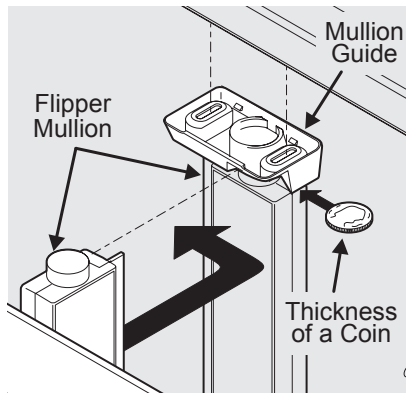

Adjusting Flipper Mullion Height

3. Re-tighten screw.

Door Removal Instructions

Getting through narrow spaces

If your refrigerator will not fit through an entrance area, you can remove the doors. Check first by measuring the entrance.

To prepare for removing the doors:

- 1 Make sure the electrical power cord is unplugged from the wall outlet.
- 2 Open the freezer drawer and remove the toe grille (see Installation section).
- 3 Remove any food from the door shelves and close the doors.

To remove the top hinge covers:

- 1 Remove the two screws from each cover over the top door hinges.
- 2 Lift inside edge of hinge cover and tilt back.

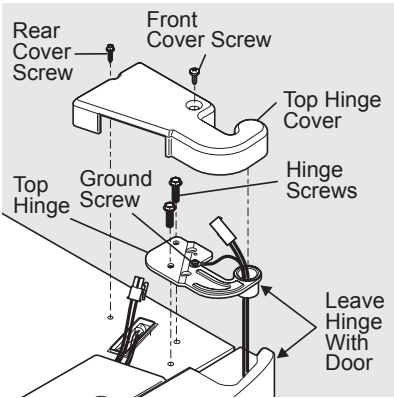
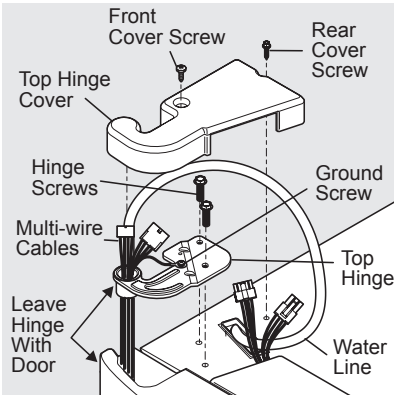

NOTE

DO NOT remove the ground screw from hinge.

To remove the refrigerator doors

- 1 Trace lightly around the door's top hinges with a pencil. This makes reinstallation easier.

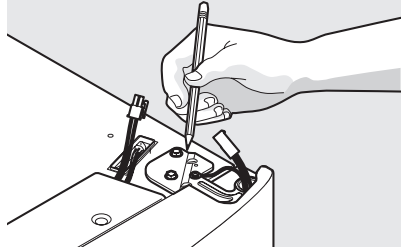

- 2 Disconnect the harness by grasping both sides of the connector firmly, depress the latch, and pull apart. Remove the two screws from the top hinge. Lift the door off of the bottom hinge and set it aside.

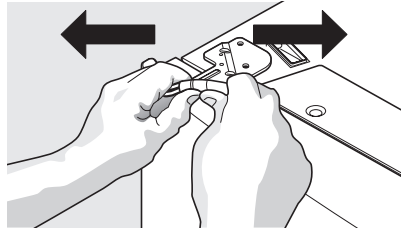

- 3 Detach the water tube from the connector located behind the refrigerator and pull the tube back out to the front of the unit. The connector releases when you press inward on the outer sleeve while pushing the tube toward the connector then while continuing to hold in the sleeve, pull the tube away.

NOTE

Use care while pulling the water tube from the unit to be sure that you do not kink the tube.

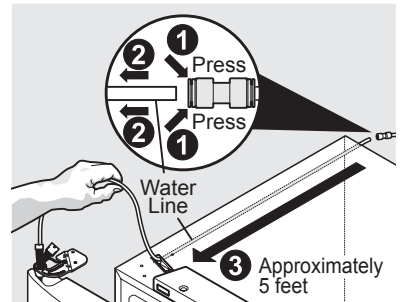

Door Removal Instructions

NOTE

You will be pulling approximately five feet of water tube from the back of the refrigerator.

- 4 Unscrew the three lower hinge screws and slide the hinge inwards.

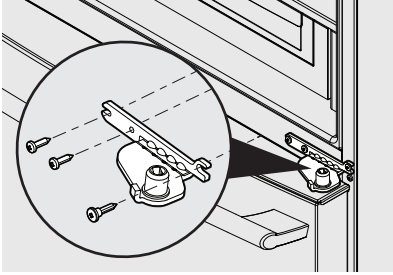

Lower Hinge Removal



CAUTION

Be sure doors are set aside in a secure position where they cannot fall and cause personal injury, or damage to the doors or handles.

To reinstall the refrigerator doors:

Reverse the above steps.

NOTE

Upon replacement, the tube needs to be fully inserted up to the marking line.

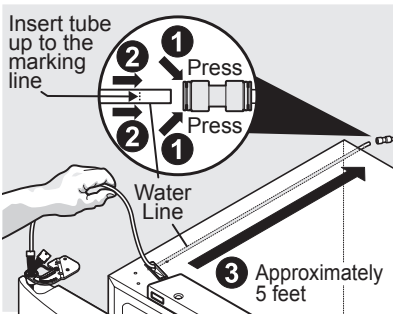

NOTE

When reinserting the water tube and replacing the top hinge cover, use care to be sure you do not kink the tube.

Once both doors are in place, ensure they are aligned with each other and level (Please see the Installation section for more details), and replace the top hinge cover.

Removing Freezer Drawer



CAUTION

Drawer is heavy. Use caution when lifting.

- 1 Remove 4 hex head drawer screws.
- 2 Lift up drawer to remove.

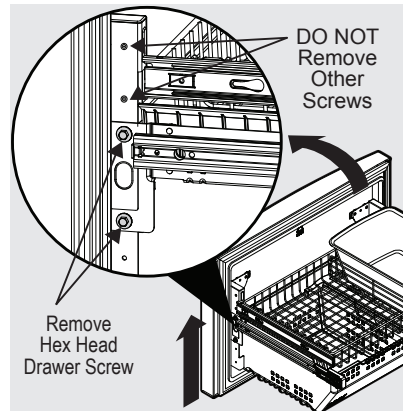

Replacing Freezer Drawer

- 1 Lower drawer back into place.
- 2 Replace 4 hex head drawer screws and tighten.

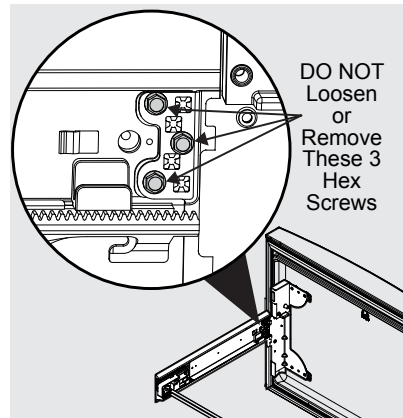

Installing Door Handles

Door Handle Mounting Instructions



CAUTION

Wear gloves and safety goggles. Use extreme CAUTION when installing these handles. The rounded end of the handles may be sharp.

1. Remove handles from carton and any other protective packaging.
2. Position fresh food handle end over upper and lower pre-installed shoulder bolts (A) that are fastened into the doors ensuring the holes for the set screws are facing towards the opposite door.
3. While holding handle firmly against door, fasten upper and lower Allen set screws (B) with supplied Allen wrench.
4. Repeat steps two and three to install opposite handle. Ensure the holes for the set screws are facing towards the first door.
5. Position freezer handle end over left and right pre-installed handle mounts that are fastened to the door, ensuring the holes for the set screws are facing down.
6. While holding handle firmly against door, loosely tighten far right Allen set screw (B) with supplied Allen wrench until there is no gap between handle and door.
7. Still holding the handle firmly to the door, firmly tighten far left Allen set screw (B) with supplied Allen wrench.
8. Return to the far right Allen set screw (B) and firmly tighten with supplied Allen wrench.

NOTE

All set screws should be tightened so that the screw is below the surface of the handle. The handles should be drawn tight to freezer and refrigerator doors with no gaps. Opening the opposite door while tightening the Allen screw makes installation easier.

The door handle may loosen over time. If this happens, tighten the set screws on the handles.

Mounting Refrigerator Handles

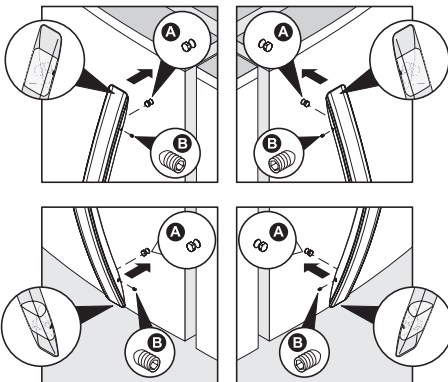

Mounting Freezer Handles

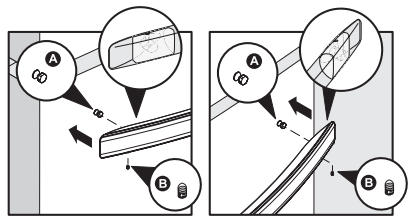

Connecting the Water Supply



WARNING

To avoid electric shock, which can cause death or severe personal injury, disconnect the refrigerator from electrical power before connecting a water supply line to the refrigerator.



CAUTION

To Avoid Property Damage:

Copper or Stainless Steel braided tubing is recommended for the water supply line. Water supply tubing made of 1/4 inch plastic is not recommended to be used. Plastic tubing greatly increases the potential for water leaks, and the manufacturer will not be responsible for any damage if plastic tubing is used for the supply line.

DO NOT install water supply tubing in areas where temperatures fall below freezing.

Chemicals from a malfunctioning water softener can damage the ice maker. If your home has a water softening system, ensure the softener is maintained and working properly.

IMPORTANT

Ensure that your water supply line connections comply with all local plumbing codes.

Before Installing The Water Supply Line, You Will Need:

Basic Tools: adjustable wrench, flat-blade screwdriver, and Phillips™ screwdriver

Access to a household cold water line with water pressure between 30 and 100 psi.

A water supply line made of 1/4 inch (6.4 mm) OD, copper or stainless steel tubing. To determine the length of tubing needed, measure the distance from the ice maker inlet valve at the back of the refrigerator to your cold water pipe. Then add approximately 7 feet (2.1 meters), so the refrigerator can be moved out for cleaning (as shown).

A shutoff valve to connect the water supply line to your household water system. **DO NOT** use a self-piercing type shutoff valve.

Do not re-use compression fitting or use thread seal tape.

A compression nut and ferrule (sleeve) for connecting a copper water supply line to the ice maker inlet valve.

NOTE

Check with your local building authority for recommendations on water lines and associated materials prior to installing your new refrigerator.

To Connect Water Supply Line To Ice Maker Inlet Valve

- 1 Disconnect refrigerator from electric power source.
- 2 Place end of water supply line into sink or bucket. Turn ON water supply and flush supply line until water is clear. Turn OFF water supply at shutoff valve.
- 3 Remove plastic cap from water valve inlet and discard cap.
- 4 If you use copper tubing - Slide brass compression nut, then ferrule (sleeve) onto water supply line. Push water supply line into water valve inlet as far as it will go (1/4 inch/6.4 mm). Slide ferrule (sleeve) into valve inlet and finger tighten compression nut onto valve. Tighten another half turn with a wrench; **DO NOT** over tighten. See Figure 1.

Connecting the Water Supply

If you use braided flexible stainless steel tubing - The nut is already assembled on the tubing. Slide nut onto valve inlet and finger tighten nut onto valve. Tighten another half turn with a wrench; DO NOT over tighten. See Figure 2.

- 5 With steel clamp and screw, secure water supply line to rear panel of refrigerator as shown.
- 6 Coil excess water supply line (copper tubing only), about 2½ turns, behind refrigerator as shown and arrange coils so they do not vibrate or wear against any other surface. Do not kink tubing.
- 7 Turn ON water supply at shutoff valve and tighten any connections that leak.
- 8 Reconnect refrigerator to electrical power source.
- 9 To turn ice maker on, lower wire signal arm (freezer ice maker) or set the ice maker's On/Off power switch to the "On" position (fresh food ice maker).

NOTE

These instructions do not cover after market ice maker installation. Instructions in after market ice maker kit should be used.

IMPORTANT

After connecting the water supply, refer to "How to Prime the Water Supply System" for important information about priming an empty water supply system.

Your refrigerator's water supply system includes several tubing lines, a water filter, a water valve, and a water tank. To ensure that your water dispenser works properly, this system must be completely filled with water when your refrigerator is first connected to the household water supply line.

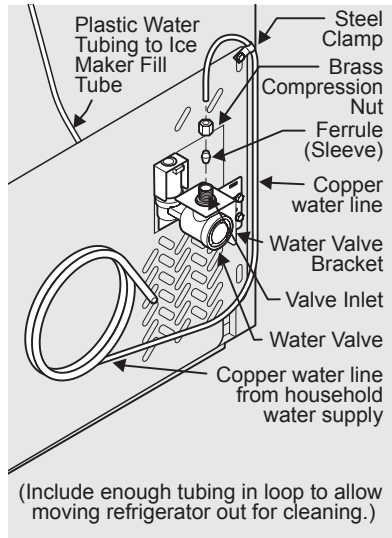

Figure 1

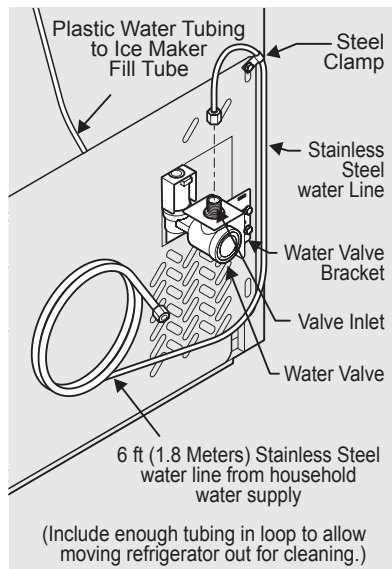
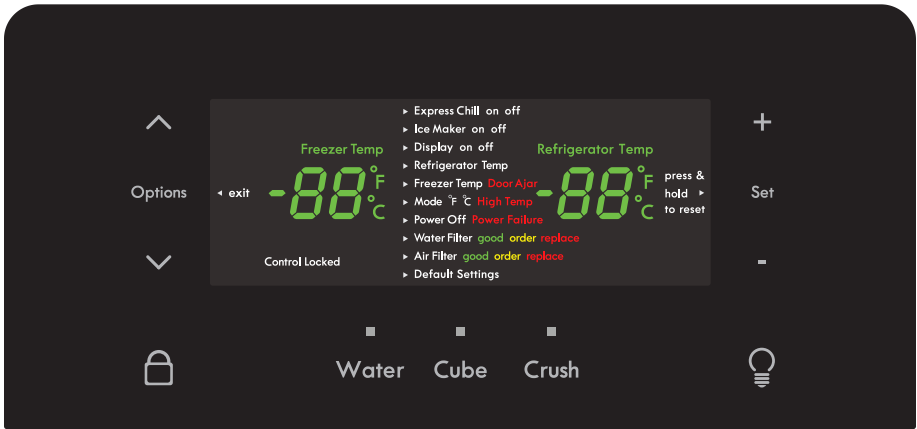

Figure 2

Controls - Dispenser Models

User Interface (options may vary)





Enlarged view of user interface display menu (options may vary)

- ▶ Express Chill on off
 - ▶ Ice Maker on off
 - ▶ Display on off
 - ▶ Refrigerator Temp
 - ▶ Freezer Temp Door Ajar
 - ▶ Mode °F °C High Temp
 - ▶ Power Off Power Failure
 - ▶ Water Filter good order replace
 - ▶ Air Filter good order replace
 - ▶ Default Settings
- Refrigerator Temp
- 88 °F
- 88 °C

Controls - Dispenser Models

Options May Vary

options (^ or v)	Used to enter and exit the options menu and make selections.
exit	Toggles the options and run modes.
control locked	While in the locked state, you will not be able to change any settings on the display nor dispense ice and water. The "Control Locked" indicator will flash and an audible warning tone is played.
	
express chill on off	Activates a faster rate for freezing food and increases ice production in the freezer. Deactivates after 12 hours.
ice maker on off	Toggles the ice maker in the refrigerator compartment "ON" or "OFF". In the "Off" state, the indicator will blink when ice is dispensed.
display on off	Toggles the display of the temperature settings On and Off.
refrigerator temp	Allows the temperature set-points to be adjusted. Control temperatures range from +33°F / +1°C to +47°F / +8°C.
freezer temp	Allows the temperature set-points to be adjusted. Control temperatures range from -6°F / -21°C to +6°F / -15°C.
mode °F °C	Toggles display from Fahrenheit to Celsius.
light 	Toggles dispenser light On and Off.
power off	Press and hold for three seconds to turn off the cooling system. It also turns off the ice maker and all dispenser functions. The display will read "power off".
water filter	Displays the current status of the water filter (Good, Order, or Replace). To reset the filter status to "Good", press and hold the "set" key for three seconds.
air filter	Displays the current status of the air filter (Good, Order, or Replace). To reset the filter status to "Good", press and hold the "set" key for three seconds.

default settings While in the default option, press and hold the "set" key for three seconds to reset all refrigerator settings to their factory default settings.

set (+ or -) Selects the current menu selection option.

water Press the "water" key to select water. An indicator light will be illuminated above the active feature.

cube Press the "cube" key to select cubed ice. An indicator light will be illuminated above the active feature.

crush Press the "crush" key to select crushed ice. An indicator light will be illuminated above the active feature.

Setting cooling temperatures (options may vary)

NOTE

The recommended settings for a product installed in a kitchen is 37°F for the fresh food compartment and 0°F for the freezer.

IMPORTANT

If your product has food freezing in the fresh food compartment, increase the temperature setting 1 or 2 degrees.

IMPORTANT

If you place food within 1 inch in front of the air ports, there may be the chance of freezing food.

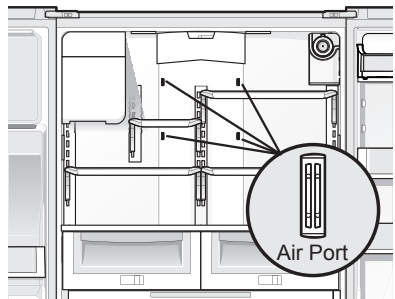

Controls - Dispenser Models

NOTE

Control features and alarms may vary by model.

Alarms

Power Failure

In the event of a power failure, the power fail alert will be illuminated. Press set to acknowledge the alarm. Other modes may be turned off until the alarm is acknowledged. While a power fail alert is displayed on the control panel, the unit will continue normal operation. The power fail alert on the control panel will be removed once in the user acknowledges the power fail condition by pressing any key on the control panel. The high temp alarm may also be illuminated until a safe operating range temperature has been reached.

Freezer Temp

If the freezer temperature reaches 26°F or greater, the alarm will sound and the temperature will flash. You can disable the alarm by pressing the set key but the “High Temp” indicator will illuminate until the temperature goes below 26°F.

Fresh Food Temp

If the fresh food temperature reaches 55°F or greater, the alarm will sound and the temperature will flash. You can disable the alarm by pressing the set key but the “High Temp” indicator will illuminate until the temperature goes below 55°F.

Door Ajar

If the freezer or fresh food doors have been left open for five minutes or more, an alarm will sound and the door ajar indicator will illuminate on the display. Press the set key to reset any system alarms.

Flapper

When “Cube” or “Crush” is selected, if the flapper (or ice chute door) is being held open by a jammed ice cube, an alarm will sound for two minutes. The alarm will reset after two minutes or when the ice cube is removed and the set key is pressed to reset.

Sabbath Mode

The Sabbath Mode is a feature that disables portions of the refrigerator and its controls in accordance with observance of the weekly Sabbath and religious holidays within the Orthodox Jewish community.

Sabbath Mode is turned ON and OFF by simultaneously pressing and holding both the “√” and “+” for five seconds. The display shows “Sb” while in Sabbath mode.

In the Sabbath Mode, the High Temp alarm is active for health reasons. For example, if the door is left ajar the High Temp alarm is activated. The refrigerator will function normally once the door is closed, without any violation of the Sabbath/Holidays. The High Temp alarm is permitted when cabinet temperature is outside the safe zone for 20 minutes. The alarm silences itself after 10 minutes while the High Temp icon stays lit until the Sabbath mode is exited.

For further assistance, guidelines for proper usage and a complete list of models with the Sabbath feature, please visit the web at <http://www.star-k.org>.



NOTE

While in Sabbath Mode, neither the lights, dispenser, nor the control panel will work until Sabbath Mode is deactivated.

Refrigerator stays in Sabbath Mode after power failure recovery. It must be deactivated with the buttons on the control panel.

NOTE

Although you have entered the Sabbath Mode, the ice maker will complete the cycle it had already initiated. The ice cube compartment will remain cold and new ice cubes can be made with standard trays.

Controls - Non-Dispenser Models



A red indicator light will be illuminated above most active features.

Touch the icon to activate the options below.

- quick ice** Increases the production of ice
- water filter** Press and hold for three seconds to reset after filter change.
- C/F** Touch to toggle display from Fahrenheit to Celsius.
- default settings** Resets all refrigerator settings such as temp, temp display and tones to their factory default settings.
- Power on-off** Press and hold for three seconds to turn off the cooling system to clean the refrigerator. It also turns off the ice maker. The temperature displays will read OFF.
- alert reset** Tones emitted by each key press can be turned off based on user preference. The sounds are muted when the red indicator is lit. Warning signals will stay active.

IMPORTANT

Pressing the power on/off icon does not turn off power to your refrigerator. You must unplug the power cord from the wall outlet.

Setting Cooling Temperatures

Press the “^” or “v” indicator to adjust the temperature to the desired setting.

The temperature display will begin to blink with the first touch. The display will time out after 10 seconds and return to the basic display.

Controls - Non-Dispenser Models

Alarms

Door Ajar If the door has been left open for an extended period of time, an alarm will sound and the door ajar indicator will display on the bottom display of the control panel. The alarm is turned off by closing the door. The mute sounds key will blink to prompt the reset of any active alarms. Press this key to reset any system alarms.

High Temp In the event of a high temperature condition, the temperature display will blink and display "HI". After 20 minutes, the alarm will sound and the high temp indicator will be red on the bottom of the control panel. The mute sounds icon will illuminate until pressed, acknowledging the alarm, at which time the highest temperature reached will be displayed and the refrigerator will resume normal operation. In case the high temp alarm is not acknowledged at the first alarm sound time out, when the door is first opened, the alarm sound will be repeated.

Power Fail In the event of a power failure, the power fail alert will be displayed and the temperature display will blink until the mute sounds icon is pressed, acknowledging the alarm. Other modes may be turned off until the alarm is acknowledged. The power fail alert is turned off and the refrigerator will resume normal operation. The high temp alarm may also be illuminated until a safe operating range temperature has been reached.

Sabbath Mode

The Sabbath Mode is a feature that disables portions of the refrigerator and its controls in accordance with observance of the weekly Sabbath and religious holidays within the Orthodox Jewish community.

Sabbath Mode is turned ON and OFF by simultaneously pressing and holding both the freezer "∨" and refrigerator "∧" indicators for five seconds. The display shows "Sb" while in Sabbath mode.

In the Sabbath Mode, the High Temp alarm is active for health reasons. For example, if the door is left ajar the High Temp alarm is activated. The refrigerator will function normally once the door is closed, without any violation of the Sabbath/Holidays. The High Temp alarm is permitted when cabinet temperature is outside the safe zone for 20 minutes. The alarm silences itself after 10 minutes while the High Temp icon stays lit until the Sabbath mode is exited.

For further assistance, guidelines for proper usage and a complete list of models with the Sabbath feature, please visit the web at <http://www.star-k.org>.



NOTE

While in Sabbath Mode, neither the lights, nor the control panel will work until Sabbath Mode is deactivated.

Refrigerator stays in Sabbath Mode after power failure recovery. It must be deactivated with the buttons on the control panel.

NOTE

During the Sabbath Mode, the automatic ice maker will continue to work and must be manually turned off to be compliant with the Sabbath observances.

Automatic Ice & Water Dispenser (select models)



CAUTION

For proper dispenser operation, recommended water supply pressure should fall between 30 psi and 100 psi. Excessive pressure may cause the system to malfunction.

Priming the water supply system

- 1 Begin filling the system by pressing and holding a drinking glass against the water dispenser paddle.
- 2 Keep the glass in this position until water comes out of the dispenser. It may take about 1½ minutes.
- 3 Continue dispensing water for about four minutes to flush the system and plumbing connections of any impurities (stopping to empty the glass as necessary).



Dispenser (varies by model)

Counter Depth model, the ice bin will hold about 4 pounds of ice.

Turning the fresh food ice maker on and off

Ice production is controlled by the ice maker's On/Off feature on the control panel. Pressing the On/Off feature turns the ice maker on & off.

IMPORTANT

Turning off the ice maker simply disables ice making. You will still be able to dispense existing ice, and you will still be able to dispense water.

NOTE

The ice maker also has a built-in plastic signal arm that automatically stops ice production when the ice bin is full. This signal arm should not be used to manually stop the ice maker.

Using the ice maker after installation

Before making ice for the first time, be sure to prime the water supply system. Air in new plumbing lines can result in two or three empty ice maker cycles. Furthermore, if the system is not flushed, the first ice cubes may be discolored or have an odd flavor.

NOTE

The water dispenser has a built-in device that shuts off the water flow after three minutes of continuous use. To reset this shutoff device, simply release the dispenser paddle.

NOTE

Dispensed water is not chilled. For colder water, add ice to cup or container before dispensing water.

IMPORTANT

Your ice maker is turned on at the factory so it can work as soon as you install your refrigerator. If you cannot connect a water supply, set the ice maker's On/Off feature to Off; otherwise, the ice maker's fill valve may make a loud chattering noise when it attempts to operate without water.

IMPORTANT

On occasion, unusually small ice cubes may be noticed in the bucket or in dispensed ice. This could occur in normal operation of the ice maker. If you start seeing these more frequently, it may be an indication of low water pressure or the water filter needs to be replaced. As the water filter nears the end of its useful life and becomes clogged with particles, less water is delivered to the ice maker during each cycle. Remember, if it's been six months or longer since you last changed your water filter, replace the water filter with a new one. Poor quality household water may require the filter to be changed more frequently.

Ice maker operation & care

After the refrigerator is installed properly and has cooled for several hours, the ice maker can produce ice within 24 hours. The ice maker will fill the ice bin from the rear. You must dispense some ice to force the ice forward in the bin. This will allow the bin to fill completely.

Ice Maker and Storage Bin Capacity

This ice maker should produce 2.5 to 3 pounds of ice per 24 hours.

In a Standard Depth model, the ice bin will hold about 6.5 pounds of ice. In a

Automatic Ice & Water Dispenser (select models)

Ice maker/dispenser tips

If your refrigerator is not connected to a water supply or the water supply is turned off, turn off the ice maker as described in the previous section.

The following sounds are normal when the ice maker is operating:

- Motor running
- Ice dropping into ice bin
- Water valve opening or closing
- Running water

If you need a large quantity of ice at one time, it is best to get cubes directly from the ice bin.

Ice cubes stored too long may develop an odd flavor. Empty the ice bin as explained below.

When dispensing cubed ice, it is normal to have a small quantity of little pieces along with the whole cubes.

To avoid splashing, dispense ice into your container before adding liquids.

It is normal for ice to fill to the top of the ice bin.

- 4 Allow the ice bin to dry completely before replacing in the freezer.
- 5 Replace the ice bin. Turn the ice maker on.

Remove and empty the ice bin if:

An extended power failure (one hour or longer) causes ice cubes in the ice bin to melt and refreeze together after power is restored, jamming the dispenser mechanism.

You do not use the ice dispenser frequently. Ice cubes will freeze together in the bin, jamming the dispenser mechanism.

Remove the ice bin and shake to loosen the cubes or clean as explained above.



CAUTION

NEVER use an ice pick or similar sharp instrument to break up the ice. This could damage the ice bin and dispenser mechanism.

To loosen stuck ice, use warm water. Before replacing the ice bin, make sure it is completely dry.



CAUTION

If the water supply to your refrigerator is softened, be sure the softener is properly maintained. Chemicals from a water softener can damage the ice maker.

Cleaning the ice maker

Clean the ice maker and ice bin at regular intervals, especially prior to vacation or moving.

- 1 Turn off the ice maker.

- 2 Remove the ice bin by pulling straight out.

- 3 Empty and carefully clean the ice bin with mild detergent.

Do not use harsh or abrasive cleaners. Rinse with clear water.

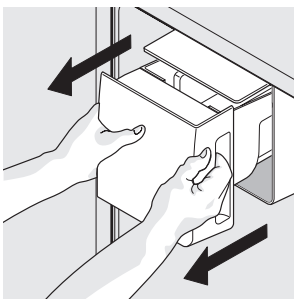

Removing Ice Bin

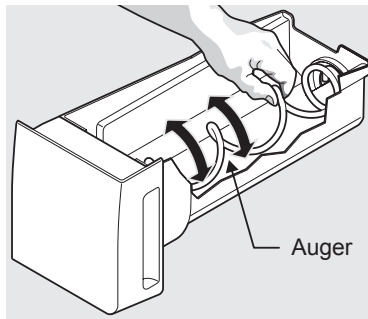

Adjusting Ice Bin Auger

IMPORTANT

When removing or replacing the ice bin, avoid rotating the auger in the ice bin. If the auger is accidentally rotated, you must realign the auger by turning it in 45 degree turns (see below) until the ice bin fits into place with the drive mechanism. If the auger is not properly aligned when replacing the ice bin, the refrigerator will not dispense ice. The fresh food door also may not close properly causing warm air to leak into the fresh food compartment.

Automatic Ice Maker - Freezer (select models)

Operation & Care of the Freezer Ice Maker (select models)

After the refrigerator is installed properly, the ice maker can produce ice within 24 hours. When using the ice maker for the first time, and in order for it to work properly, it is necessary to clear air from the water tubing and the filter. Furthermore, if the system is not flushed, the first ice cubes may be discolored or have an odd flavor. Once the ice maker begins making ice, allow the bin to fill completely, then discard the first FULL bin of ice on a Standard Depth model, and the first TWO FULL bins of ice on a Counter Depth model.

Ice Maker and Storage Bin Capacity

This ice maker should produce between 2 and 2.5 pounds of ice per 24 hours depending on usage conditions. In a Standard Depth model, the ice bin will hold about 12 pounds of ice. In a Counter Depth model, the ice bin will hold about 7 pounds of ice.

IMPORTANT

Your ice maker is turned on at the factory so it can work as soon as you install your refrigerator. If you cannot connect a water supply, lift the ice maker's wire signal arm to turn it off. Otherwise, the ice maker's fill valve may make a loud chattering noise when it attempts to operate without water.

Turning the ice maker on and off

The ice maker is turned off and on by lifting/lowering the ice maker's wire signal arm. To gain access to the ice maker, pull the freezer drawer out. Lift the wire signal arm to turn the ice maker OFF and lower the wire signal arm to turn it ON.

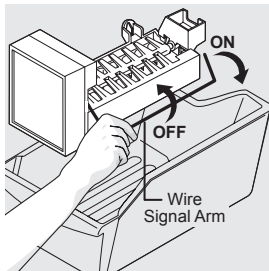

Ice maker tips

The following sounds are normal when the ice maker is operating:

- Motor running
- Ice dropping into ice bin
- Water valve opening or closing
- Running water

Ice cubes stored too long may develop an odd flavor. Empty the ice bin as explained below.



CAUTION

If the water supply to your refrigerator is softened, be sure the softener is properly maintained. Chemicals from a water softener can damage the ice maker.

Express Chill Function

Your refrigerator is equipped with a Express Chill Function for freezing food at a faster rate, but it can also increase ice production. This function terminates automatically after 12 hours. This function affects only the ice maker in the freezer.

NOTE

For Non Dispenser models choose the Quick Ice Function.

Cleaning the ice maker

Clean the ice maker and ice bin at regular intervals, especially prior to vacation or moving.

- 1 Turn off the ice maker.
- 2 Remove the ice bin.
- 3 Empty and carefully clean the ice bin with mild detergent. Do not use harsh or abrasive cleaners. Rinse with clean water.
- 4 Allow the ice bin to dry completely before replacing in the freezer.
- 5 Replace the ice bin. Turn the ice maker on.

Remove and empty the ice bin if an extended power failure (one hour or longer) causes ice cubes in the ice bin to melt and refreeze together after power is restored.

Remove the ice bin and shake to loosen the cubes or clean as explained above.



CAUTION

NEVER use an ice pick or similar sharp instrument to break up the ice. This could damage the ice bin.

To loosen stuck ice, use warm water. Before replacing the ice bin, make sure it is completely dry.

Storage Features



CAUTION

To avoid personal injury or property damage, handle tempered glass shelves carefully. Shelves may break suddenly if nicked, scratched, or exposed to sudden temperature change. Allow the glass shelves to stabilize to room temperature before cleaning. Do not wash in dishwasher.

NOTE

Features may vary according to model.

Your refrigerator includes Spill-Proof™ glass shelves that are designed to catch and hold accidental spills.

You can easily adjust shelf positions in the fresh food compartments to suit your needs. The shelves have mounting brackets that attach to slotted supports at the rear of each compartment.

IMPORTANT

Be aware of the air seal located at the rear of the shelf. Shelves located on the left side should have the air seal mounted on the far left side. Shelves located on the right side should have the air seal mounted on the far right side. This is to ensure there is no interference with the large air tower on the back wall of the cabinet. This also applies to the crisper shelves.

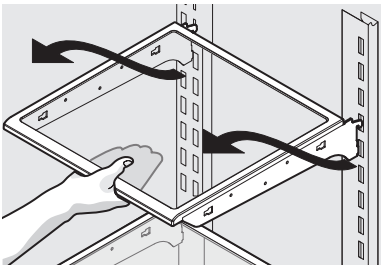

Full Spill-Proof™ Shelf

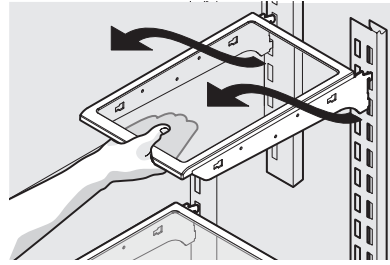

Half Spill-Proof™ Shelf

Change the Position of a Shelf

- 1 Remove all food from shelf.
- 2 Lift the front edge up and pull the shelf out.
- 3 Replace by inserting the mounting bracket hooks into the desired support slots.
- 4 Lower the shelf and lock into position.

Reposition the Air Seal

For slide-out shelves & crisper shelves:

- 1 Remove air seal by pushing down on the flap with a downward rotation.
- 2 Position the air seal towards the outside end of the shelf to avoid the air tower when shelf is pushed back into place.
- 3 Install seal by sliding lower tab of seal up into bottom rear slot of shelf with seal at a downward angle then pulling up on seal flap until seal sits snug on back of shelf and flap sits at about a 10 degree angle from shelf surface.

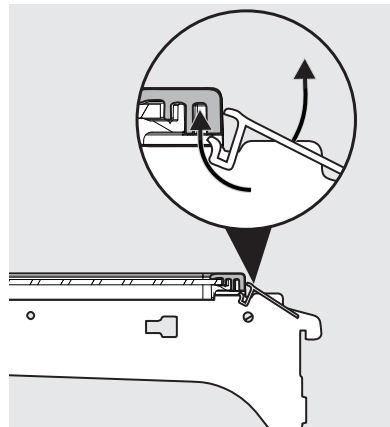

Storage Features

Drawers

Your refrigerator includes a variety of storage drawers.

Crispers

Crisper drawers are designed for storing fruits, vegetables, and other fresh produce.

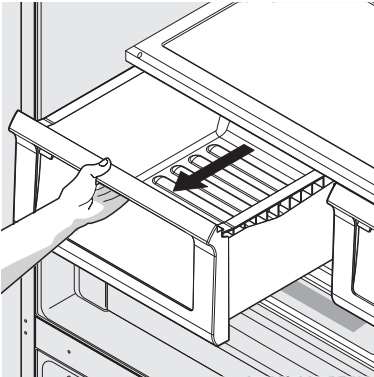

Opening Crisper Drawer

To remove the Crisper Drawer for cleaning:

- 1 Pull the drawer out until it stops.
- 2 Lift the front slightly and remove the drawer.

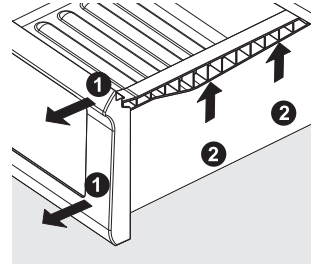

Removing Crisper Drawer

Deli drawer

Ideal for storage of deli meats and cheese.

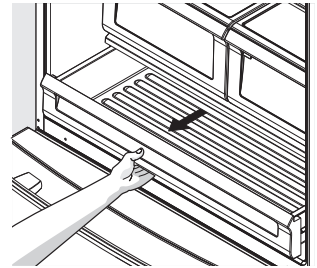

Crisper humidity control

Crisper drawers include a sliding control for adjusting the humidity inside the crisper. Leafy vegetables keep best when stored with the Humidity Control set on Higher Humidity. Fresh fruits keep best when stored with the Humidity Control set on Lower Humidity.

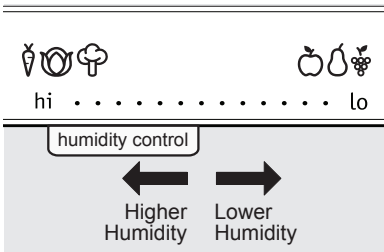

Adjusting Crisper Humidity

Doors

Storage bins

The doors to your fresh food compartment use a system of modular storage bins. All of these bins are removable for easy cleaning. Some of them have fixed positions, while others can be adjusted to your needs.

Storage Features

Door bins are ideal for storing jars, bottles, cans, and large drink containers. They also enable quick selection of frequently used items.

To change the position of an adjustable door bin:

- 1 Remove all food from door bin.
- 2 Grip the bin firmly with both hands and lift it upward.
- 3 Remove the bin.
- 4 Place the bin just above desired position.
- 5 Lower the bin onto supports until locked in place.

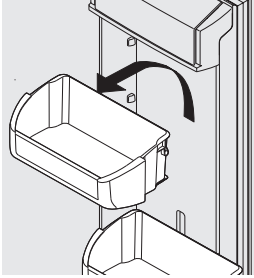

Adjustable Door Bin

Accessories (varies by model)

Dairy compartment

Use the dairy compartment, at the top of the fresh food compartment door, for short-term storage of cheese, spreads, or butter. The dairy compartment is designed to be warmer than the open area and includes a lift-up cover and a dairy divider (select models).

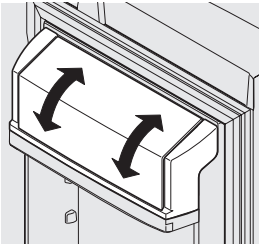

Dairy Compartment

Freezer Features (varies by model)

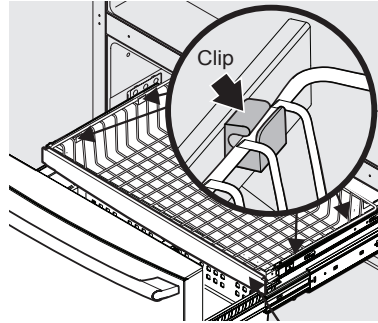

Freezer Baskets

To Remove Upper Freezer Basket

- 1 Find the side where the basket frame is aligned to the clip opening. The basket frame should be aligned to both front and rear clips on the same side (either left or right side).
- 2 If the basket frame is not aligned to the left or right side, push the basket sideways (to either side) until it is aligned.
- 3 By grabbing the basket wire frame close to the frontal clip, pull up to take the basket frame out.
- 4 Grab the basket frame close to the rear clip and pull up until it comes out of the clip.
- 5 Once one side of the basket is off the clips or retainers, slide the basket sideways until the other side of the frame is aligned with the clip openings on the opposite side of the freezer.
- 6 In the same way, pull up the basket frame from the frontal and rear clips until it is out of the clips.
- 7 Remove the basket.

Reverse the steps to reinstall the basket.

NOTE

If basket is not resting on stabilizer bar retainer clips, the drawer will not close properly.

Storage Features

Removing Freezer Basket Instructions

- 1 Locate the basket clips in the rear corners of the basket and pull them out to remove.
- 2 Open fresh food doors completely.
- 3 Lift the basket up and remove.

Replacing Freezer Basket Instructions

- 1 Place freezer basket back inside the freezer drawer.
- 2 Replace clips by sliding them back into the slots.

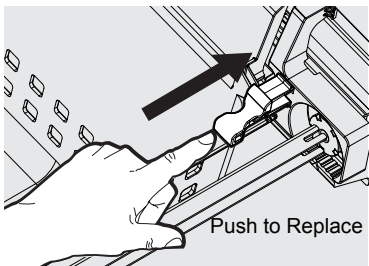
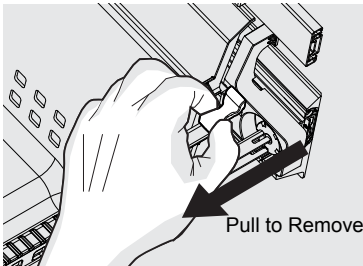
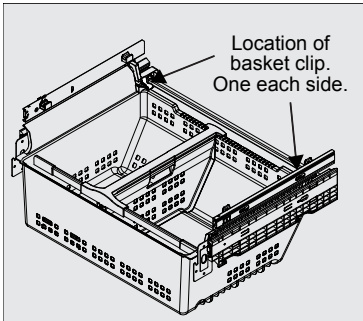

Dividers Removal

Lift up on the front of the upper divider and pull out.

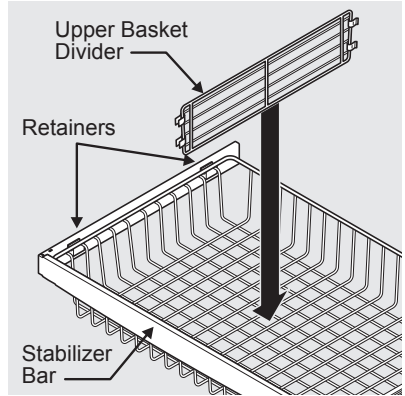

Upper Basket Divider

Squeeze handle and lift up in the center of the divider to move it side-to-side. (The divider cannot be removed.)

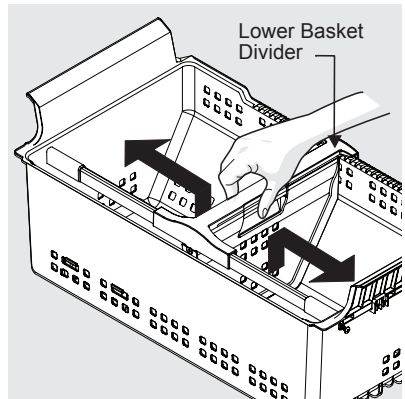

Plastic Lower Basket Divider

Tilt Wire Shelf

The freezer tilt wire shelf (located on the inside of the freezer drawer) is not designed to be removed.

Storing Food and Saving Energy

Ideas for storing foods

Fresh food storage

- Keep the fresh food compartment between 34°F and 40°F with an optimum temperature of 37°F.
- Avoid overcrowding the refrigerator shelves, which reduces air circulation and causes uneven cooling.
- Avoid placing food in front of air ports. (See Controls Section for illustration.)

Fruits and vegetables

- Store fruits and vegetables in crisper drawers, where trapped moisture helps preserve food quality for longer time periods.
- Wash items and remove excess water.
- Wrap any items that have strong odors or high moisture content.

Meat

- Wrap raw meat and poultry separately and securely to prevent leaks and contamination of other foods or surfaces.
- Use the deli drawer to store meat/poultry for short-term storage. Any meat to be kept longer than two days should be frozen.

Frozen food storage

- Keep the freezer compartment at 0°F or lower.
- A freezer operates most efficiently when it is at least $\frac{2}{3}$ full.

Packaging foods for freezing

- To minimize food dehydration and quality deterioration, use aluminum foil, freezer wrap, freezer bags, or airtight containers. Force as much air out of the packages as possible and seal them tightly. Trapped air can cause food to dry out, change color, and develop an off-flavor (freezer burn).
- Wrap fresh meats and poultry with suitable freezer wrap prior to freezing.
- Do not refreeze meat that has completely thawed.

Loading the freezer

- Prior to grocery shopping, activate “Express Chill” (some models) so that on your return you can ensure your newly

purchased food designated for the freezer will be preserved as quickly as possible.

- Activating “Express Chill” (some models) also will help your freezer more efficiently maintain the selected temperature after placing new purchases with pre-existing frozen foods.
- Avoid adding too much warm food to the freezer at one time. This overloads the freezer, slows the rate of freezing, and can raise the temperature of frozen foods.
- Leave a space between packages, so cold air can circulate freely, allowing food to freeze as quickly as possible.

Ideas for saving energy

Installation

- Locate the refrigerator in the coolest part of the room, out of direct sunlight, and away from heating ducts or registers.
- Do not place the refrigerator next to heat-producing appliances such as a range, oven, or dishwasher. If this is not possible, a section of cabinetry or an added layer of insulation between the two appliances will help the refrigerator operate more efficiently.
- Level the refrigerator so that the doors close tightly.

Temperature settings

- Refer to the “Controls” section for procedures on temperature settings.

Food storage

- Avoid overcrowding the refrigerator or blocking cold air vents. Doing so causes the refrigerator to run longer and use more energy.
- Cover foods and wipe containers dry before placing them in the refrigerator. This cuts down on moisture build-up inside the unit.
- Organize the refrigerator to reduce door openings. Remove as many items as needed at one time and close the door as soon as possible.
- Do not place a hot container directly on a cold shelf. Remember, such an extreme temperature change may damage the glass.

Normal Operating Sounds and Sights

Understanding the sounds you may hear

Your new, high-efficiency refrigerator may introduce unfamiliar sounds. These sounds normally indicate your refrigerator is operating correctly. Some surfaces on floors, walls, and kitchen cabinets may make these sounds more noticeable.

The following is a list of major components in your refrigerator and the sounds they can cause:

- A Evaporator** - Refrigerant through the evaporator may create a boiling or gurgling sound.
- B Evaporator fan** - You may hear air being forced through the refrigerator by the evaporator fan.
- C Defrost heater** - During defrost cycles, water dripping onto the defrost heater may cause a hissing or sizzling sound. After defrosting, a popping sound may occur.
- D Automatic ice maker** - When ice has been produced, you will hear ice cubes falling into the ice bin. Ice maker fan, water valve activation, and refrigerant gas fluid may create sounds from its operation.
- E Electronic control & automatic defrost control** - These parts can produce a snapping or clicking sound when turning the cooling system on and off.
- F Condenser fan** - You may hear air being forced through the condenser.
- G Compressor** - Modern, high-efficiency compressors run much faster than older models. The compressor may have a high-pitched hum or pulsating sound.
- H Water valve** - Makes a buzzing sound each time it opens to fill the ice maker.
- I Drain pan (not removable)** - You may hear water dripping into the drain pan during the defrost cycle.
- J Condenser** - May create minimal sounds from forced air.

- L Ice dispensing paddle** - When dispensing ice, you will hear a snapping, clicking, or popping sound.
- M Motorized damper** - May produce a light humming during operation.

NOTE

Energy efficient foam in your refrigerator is not a sound insulator.

NOTE

During automatic defrost cycle, a red glow in the back wall vents of your freezer compartment is normal.

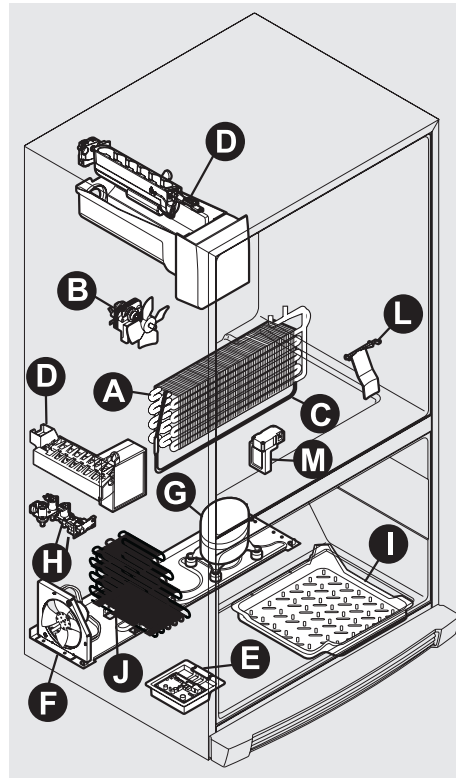

Features vary by model

Changing the Filter

Air filter (select models)

The air filter is located under the utility bin.

Replacing your Kenmoreclean™ air filter

To ensure optimal filtering of refrigerator odors, you should change the air filter every six months (the filter status light on the Touch Panel prompts you to replace the filter after six months).

- 1 Open the air filter door.
- 2 Remove the old filter and discard it.
- 3 Unpack the new filter and slide it into the housing. The open face of the filter should be installed facing downward.
- 4 To close the air filter door, push the top and bottom to lock the door closed.
- 5 Press and hold the Air Filter Reset button on the control panel for three seconds. When the display changes from “Replace” to “Good,” the status has been reset.
- 6 The Air Filter Reset will turn itself off after a few seconds.

Ordering replacement filters

Order new filters through the dealer where you bought your refrigerator. You may want to consider ordering extra filters when you first install your refrigerator.

Air Filter Replacement cartridge, part #9920

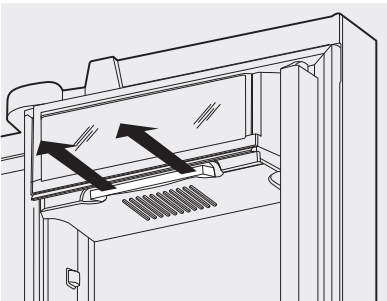
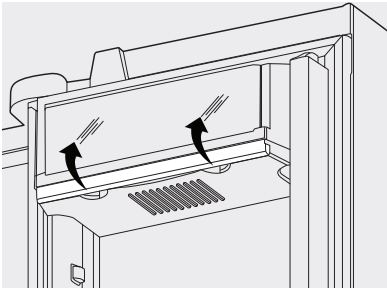

Changing the Filter

Locating the Filters

Your refrigerator is equipped with water filtering system. The water filter system filters the water used to produce ice.

Water Filter

The water filter is located at the top right side of the fresh food compartment.

Replacing the Water Filter

In general, you should change the water filter every six months to ensure the highest possible water quality. **Water Filter Status** on the user interface prompts you to replace the filter after a standard amount of water (200 gallons/757 liters for **Kenmorepure!**[™]) has flowed through the system.

If your refrigerator has not been used for a period of time (during moving for example), change the filter before reinstalling the refrigerator.

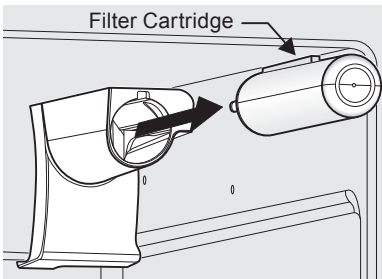

Ordering Replacement Filters

To order your replacement filters, please visit the dealer where you purchased your refrigerator. Sears recommends that you order extra filters when you first install your refrigerator, and that you replace your filters at least once every six months.

Here is the product number to request when ordering:

Kenmorepure![™] Water Filter
Part #046-9999

NOTE

When ordering your replacement filter, please reorder the same filter type that is currently in your refrigerator.

More about your Advanced Water Filter



The **Kenmorepure!**[™] ice and water filter system is tested and certified to NSF/ANSI Standards 42 and 53 for the reduction of claims specified on the performance data sheet.

Do not use with water that is microbiologically unsafe or of unknown quality without adequate disinfection before or after the system. Systems certified for cyst reduction may be used on disinfected waters that may contain filterable cysts.

Test & Certification Results:

- Rated Capacity - 200 gallons/757 liters for **Kenmorepure!**[™] ice and water filter
- Rated service flow - .50 gallons per minute
- Operating Temp.: Min. 33°F, Max. 100°F
- Maximum Rated Pressure - 100 pounds per square inch
- Recommended Minimum Operating Pressure: 30 pounds per square inch

To Replace your Kenmorepure![™] Water Filter:

It is not necessary to turn the water supply off to change the filter. Be ready to wipe up any small amounts of water released during the filter replacement.

1. Turn Off ice maker.
2. Remove the filter by pushing on the end/face of the filter.
3. Slide the old water filter cartridge straight out of the housing and discard it.
4. Unpackage the new filter cartridge. Using the alignment guide, slide it gently into the filter housing until it stops against the snap-in connector at the back of the housing.
5. Push firmly until the cartridge snaps into place (you should hear a click as the cartridge engages the snap-in connector).
6. Turn On ice maker.
7. To reset the water filter on your IQ-Touch control, press and hold the water filter icon for three seconds. When the display changes from Red to Green, the status has been reset.

Care & Cleaning

Protecting your investment

Keeping your refrigerator clean maintains its appearance and prevents odor build-up. Wipe up any spills immediately and clean the freezer and fresh food compartments at least twice a year.

NOTE

Do not use abrasive cleaners such as window sprays, scouring cleansers, flammable fluids, cleaning waxes, concentrated detergents, bleaches, or cleansers containing petroleum products on plastic parts, interior doors, gaskets, or cabinet liners. Do not use paper towels, scouring pads, or other abrasive cleaning materials.

- Never use metallic scouring pads, brushes, abrasive cleaners, or strong alkaline solutions on any surface.
- Never use CHLORIDE or cleaners with bleach to clean stainless steel.
- Do not wash any removable parts in a dishwasher.
- Always unplug the electrical power cord from the wall outlet before cleaning.

NOTE

If you set your temperature controls to turn off cooling, power to lights and other electrical components will continue until you unplug the power cord from the wall outlet.

- Remove adhesive labels by hand. Do not use razor blades or other sharp instruments which can scratch the appliance surface.
- Do not remove the serial plate. Removal of your serial plate voids your warranty.
- Before moving your refrigerator, raise the anti-tip brackets so the rollers will work correctly. This will prevent the floor from being damaged.



CAUTION

Pull the refrigerator straight out to move it. Shifting it from side to side may damage flooring. Be careful not to move the refrigerator beyond the plumbing connections.

Damp objects stick to cold metal surfaces. Do not touch refrigerated surfaces with wet or damp hands.

IMPORTANT

If you store or move your refrigerator in freezing temperatures, be sure to completely drain the water supply system. Failure to do so could result in water leaks when the refrigerator is put back into service. Contact a service representative to perform this operation.

Refer to the guide on the next page for details on caring and cleaning specific areas of your refrigerator.

Vacation and moving tips

Occasion Tips

- | | |
|-----------------|--|
| Short Vacations | <ul style="list-style-type: none">• Leave refrigerator operating during vacations of three weeks or less.• Use all perishable items from refrigerator compartment.• Turn automatic ice maker off and empty ice bucket, even if you will only be gone a few days. |
| Long Vacations | <ul style="list-style-type: none">• Remove all food and ice if you will be gone one month or more.• Turn the cooling system off (see “Controls” section for location of On/Off button) and disconnect power cord.• Turn water supply valve to closed position.• Clean interior thoroughly.• Leave both doors open to prevent odors and mold build-up. Block doors open if necessary. |
| Moving | <ul style="list-style-type: none">• Remove all food and ice.• If using a handcart, load from the side.• Adjust rollers all the way up to protect them during sliding or moving.• Pad cabinet to avoid scratching surface. |

Care & Cleaning

Care & Cleaning Tips		
Part	What To Use	Tips and Precautions
Interior & Door Liners	<ul style="list-style-type: none"> • Soap and water • Baking soda and water 	<ul style="list-style-type: none"> • Use two tablespoons of baking soda in one quart of warm water. Be sure to wring excess water out of sponge or cloth before cleaning around controls or any electrical part.
Door Gaskets	<ul style="list-style-type: none"> • Soap and water 	<ul style="list-style-type: none"> • Wipe gaskets with a clean soft cloth.
Drawers & Bins	<ul style="list-style-type: none"> • Soap and water 	<ul style="list-style-type: none"> • Use a soft cloth to clean drawer runners and tracks.
Glass Shelves	<ul style="list-style-type: none"> • Soap and water • Glass cleaner • Mild liquid sprays 	<ul style="list-style-type: none"> • Allow glass to warm to room temperature before immersing in warm water.
Toe Grille	<ul style="list-style-type: none"> • Soap and water • Mild liquid sprays • Vacuum attachment 	<ul style="list-style-type: none"> • Vacuum dust from front of toe grille. Remove toe grille (see Installation Instructions). Vacuum backside, wipe with sudsy cloth or sponge. Rinse and dry.
Exterior & Handles	<ul style="list-style-type: none"> • Soap and water • Non Abrasive Glass Cleaner 	<ul style="list-style-type: none"> • Do not use commercial household cleaners containing ammonia, bleach or alcohol to clean handles. Use a soft cloth to clean smooth handles. DO NOT use a dry cloth to clean smooth doors.
Exterior & Handles (Stainless Steel Models Only)	<ul style="list-style-type: none"> • Soap and water • Stainless Steel Cleaners 	<ul style="list-style-type: none"> • Never use CHLORIDE or cleaners with bleach to clean stainless steel. • Clean stainless steel front and handles with non-abrasive soapy water and a dishcloth. Rinse with clean water and a soft cloth. Use a non-abrasive stainless steel cleaner. These cleaners can be purchased at most home improvement or major department stores. Always follow manufacturer's instructions. Do not use household cleaners containing ammonia or bleach. • NOTE: Always clean, wipe and dry with the grain to prevent scratching. Wash the rest of the cabinet with warm water and mild liquid detergent. Rinse well, and wipe dry with a clean soft cloth.

Before You Call

Concern	Potential Cause	Common Solution
Automatic Ice Maker		
Ice maker is not making any ice.	<ul style="list-style-type: none"> • Ice maker is turned off. • Refrigerator is not connected to water line or water valve is not open. • The water supply line is kinked. • The water filter is not seated properly. • The water filter may be clogged with foreign material. • Freezer ice maker wire signal arm is being held up by an item not allowing it to go in the on or down position. 	<ul style="list-style-type: none"> • Turn on ice maker. For the fresh food ice maker, press ice maker on-off once. For the freezer ice maker, lower the arm to turn the ice maker on, or raise it and snap it in its upper position to turn the ice maker off. • Connect the unit to the household water supply and ensure the water valve is open. • Ensure that the supply line does not kink when the refrigerator is pushed into place against the wall. • Remove and re-install the water filter. Be sure to push firmly until the cartridge snaps into place. • If water dispenses slowly or not at all, or if the filter is six months old or older, it should be replaced. • Move any item or frozen ice cubes that may block the signal arm from being in the on or down position. Additionally, the ice bin itself may be out of position so that it prevents the signal arm from dropping all the way down. Be sure the bin is pushed all the way to the rear of the shelf. See Automatic Ice Maker-Freezer section in manual.

Before You Call

Concern	Potential Cause	Common Solution
Automatic Ice Maker (Cont'd)		
Ice maker is not making enough ice.	<ul style="list-style-type: none"> • Ice maker is producing less ice than you expect. • The water filter may be clogged with foreign material. • The water supply line is kinked. • Saddle valve on cold water pipe is clogged or restricted by foreign material. • Heavy traffic, opening or closing of the doors excessively. • Freezer control is set too warm (freezer ice maker). • Water pressure is extremely low. Cut-off and cut-on pressures are too low (well systems only). • Reverse osmosis system is in regenerative phase. 	<ul style="list-style-type: none"> • The ice maker will produce approximately 2.3 pounds of ice (fresh food ice maker) and 2.5 pounds of ice (freezer ice maker) every 24 hours depending on usage conditions. • If water dispenses slower than normal, or if the filter is six months old or older, it should be replaced. • Ensure that the supply line does not kink when the refrigerator is pushed into place against the wall. • Turn off household water line valve. Remove valve. Ensure that valve is not a self-piercing saddle valve. Clean valve. Replace valve if necessary. • Press Express Chill to temporarily increase ice production rate. (Freezer ice maker only.) Press Quick Ice for Non Dispenser models. • Set freezer control to colder setting to improve performance of the ice maker (freezer ice maker). Allow 24 hours for temperature to stabilize. • Have someone turn up the cut-off and cut-on pressure on the water pump system (well systems only). • It is normal for a reverse osmosis system to be below 20 psi during the regenerative phase.
Freezer ice maker will not stop making ice (select models).	<ul style="list-style-type: none"> • Ice maker wire signal arm is being held down by a package in the freezer that has fallen against ice maker. 	<ul style="list-style-type: none"> • Move any item or frozen ice cubes that may block the signal arm from being in the off or upward position. See Automatic Ice Maker-Freezer section in manual.
Ice cubes are freezing together.	<ul style="list-style-type: none"> • Ice cubes are not being used frequently enough or interruption of power for prolonged time. • Ice cubes are hollow (shells of ice with water inside). The hollow cubes break open in the bin and leak their water onto existing ice, which causes it to freeze together. 	<ul style="list-style-type: none"> • Remove ice container and discard ice. The ice maker will produce fresh supply. Ice should be used at least twice weekly to keep the cubes separated. • This generally occurs when the ice maker does not get enough water. This is usually the result of a clogged water filter or restricted water supply. Replace the water filter and if the condition still occurs check for a Saddle Valve, water valve not turned on all the way or kinked water supply line.

Before You Call

Concern	Potential Cause	Common Solution
Dispenser (Ice & Water)		
Dispenser will not dispense ice.	<ul style="list-style-type: none"> • There is no ice in the bin to be dispensed. • The refrigerator doors are not completely closed. • Dispenser paddle has been pressed too long and the dispenser motor has overheated. 	<ul style="list-style-type: none"> • See the “Ice maker is not making any ice” section above. • Be sure the refrigerator doors are completely closed. • The motor overload protector will reset in about three minutes and then ice can be dispensed.
Ice dispenser is jammed.	<ul style="list-style-type: none"> • Ice has melted and frozen around auger due to infrequent use, temperature fluctuations, and/or power outages. • Ice cubes are jammed between ice maker and back of ice container. 	<ul style="list-style-type: none"> • Remove ice container, thaw, and empty the contents. Clean container, wipe dry, and replace in proper position. When new ice is made, dispenser should operate. • Remove ice cubes that are jamming the dispenser.
Dispenser will not dispense water.	<ul style="list-style-type: none"> • Water filter not seated properly. • Water filter is clogged. • Household water line valve is not open. 	<ul style="list-style-type: none"> • Remove and reinstall the water filter. For Kenmorepure™, be sure to push firmly until the cartridge snaps into place. • Replace filter cartridge. Be sure to push firmly until the cartridge snaps into place. • Open household water line valve. See CONCERN column AUTOMATIC ICE MAKER.
Water not cold enough.	<ul style="list-style-type: none"> • The water dispensing system is not designed to chill water. 	<ul style="list-style-type: none"> • Add ice to cup or container before dispensing water.
Water has an odd taste and/or odor.	<ul style="list-style-type: none"> • Water has not been dispensed for an extended period of time. • Unit not properly connected to cold water line. 	<ul style="list-style-type: none"> • Draw and discard 10-12 glasses of water to freshen the supply. • Connect unit to cold water line that supplies water to the kitchen faucet.
Ice maker is not making enough ice.	<ul style="list-style-type: none"> • Heavy traffic, opening or closing of the doors excessively. 	<ul style="list-style-type: none"> • Press Quick Freeze to temporarily increase ice productions rate.

Before You Call

Concern	Potential Cause	Common Solution
Opening/Closing Of Doors/Drawers		
Door(s) will not close.	<ul style="list-style-type: none"> • Door was closed too hard, causing other door to open slightly. • Refrigerator is not level. It rocks on the floor when moved slightly. • Refrigerator is touching a wall or cabinet. 	<ul style="list-style-type: none"> • Close both doors gently. • Ensure floor is level and solid, and can adequately support the refrigerator. Contact a carpenter to correct a sagging or sloping floor. • Ensure floor is level and solid, and can adequately support the refrigerator. Contact a carpenter to correct a sagging or sloping floor.
Drawers are difficult to move.	<ul style="list-style-type: none"> • Food is touching shelf on top of drawer. • Track that drawers slide on is dirty. 	<ul style="list-style-type: none"> • Remove top layer of items in drawer. • Ensure drawer is properly installed on track. • Clean drawer, rollers, and track. See Care & Cleaning.
Running of Refrigerator		
Compressor does not run.	<ul style="list-style-type: none"> • Freezer control is set to "OF". • Refrigerator is in defrost cycle. • Plug at electrical outlet is disconnected. • House fuse blown or tripped circuit breaker. • Power outage. 	<ul style="list-style-type: none"> • Set freezer control. • This is normal for a fully automatic defrost refrigerator. The defrost cycle occurs periodically, lasting about 30 minutes. • Ensure plug is tightly pushed into outlet. • Check/replace fuse with a 15 amp time-delay fuse. Reset circuit breaker. • Check house lights. Call local electric company.
Refrigerator seems to run too much or too long.	<ul style="list-style-type: none"> • Your variable speed compressor is designed to run 100% of the time except during the defrost cycle. At times it will run faster, such as after a defrost cycle. 	<ul style="list-style-type: none"> • It is normal for the compressor to run continuously except during defrost mode.
Digital Temperature Setting Display		
Digital temperature displays an error.	<ul style="list-style-type: none"> • Electronic control system has detected a performance problem. 	<ul style="list-style-type: none"> • Call your Sears Home service representative, who can interpret any messages or number codes flashing on the digital displays.

Before You Call

Concern	Potential Cause	Common Solution
Water/Moisture/Frost Inside Refrigerator		
Moisture collects on inside of refrigerator walls.	<ul style="list-style-type: none"> • Weather is hot and humid. • Flipper mullion 	<ul style="list-style-type: none"> • The rate of frost buildup and internal sweating increases. • Adjust flipper mullion. (See “To adjust the flipper mullion” in the Installation section.)
Water collects on bottom side of drawer cover.	<ul style="list-style-type: none"> • Vegetables contain and give off moisture. 	<ul style="list-style-type: none"> • It is not unusual to have moisture on the bottom side of the cover. • Move humidity control (some models) to lower setting.
Water collects in bottom of drawer.	<ul style="list-style-type: none"> • Washed vegetables and fruit drain while in the drawer. 	<ul style="list-style-type: none"> • Dry items before putting them in the drawer. Water collecting in bottom of drawer is normal.
Water/Moisture/Frost Outside Refrigerator		
Moisture collects on outside of refrigerator or between doors.	<ul style="list-style-type: none"> • Weather is humid. 	<ul style="list-style-type: none"> • This is normal in humid weather. When humidity is lower, the moisture should disappear.
Food in Fresh Food Compartment		
Food is freezing.	<ul style="list-style-type: none"> • Temperature setting is too low. • Temperature sensor is covered by food (right side of fresh food area). • Food is covering the air ports. 	<ul style="list-style-type: none"> • Move the setting to a higher degree. • Allow space for air flow to the sensor. • Allow space between the air ports and the food.