

CHEFMAN

RJ02-180-4

MULTI-FUNCTIONAL
180° GRILL +
PANINI PRESS



CUSTOMER SERVICE: 888.315.6553 | customerservice@chefman.com



READ ALL INSTRUCTIONS BEFORE USE

For your safety and continued enjoyment of this product, always read the instruction manual before using.

Contents

- 1** Introduction
- 2** Safety Instructions
- 5** Features
- 7** Operating Instructions
- 15** Cleaning and Maintenance
- 17** Notes
- 19** Terms and Conditions
- 20** Warranty Card

INTRODUCTION

Congratulations on your purchase!

Every Chefman product is manufactured to the highest standards of performance and safety, and we are confident that you will be so satisfied with your purchase that Chefman will be your go-to company for appliances in the future.

Customer satisfaction is a key element of our company's philosophy. The Chefman brand exists to fill a void on retail shelves and in consumer kitchens for a truly value-focused kitchen appliance. By questioning and adding value and innovation at every touch point in the manufacturer to end user journey, Chefman provides home chefs with the tools they need to achieve picture-perfect results with maximum efficiency. In addition to manufacturing appliances that are dependable, affordable, and built with intuitive features to enhance your kitchen experience, we pride ourselves on providing top-of-the line post purchase support, which includes complimentary access to ClubChefman.com for product tutorials, delicious recipes & how-to videos, and access to our team of dedicated Chefs.

Should a problem arise, each product is backed by a comprehensive manufacturer's 1-year warranty as well as outstanding after-sales service support through our dedicated customer service team. In the unlikely event that your product does not operate as described in the manual please feel free to call or email our helpline for assistance. We understand that sometimes products can malfunction, so if you feel that your appliance is not operating as it should, warranty claims can be made within one year from the date of purchase when accompanied by a dated receipt.

This guarantee is in addition to your statutory rights; your statutory rights are not affected. This limited warranty does not apply in cases of damage caused by accident, improper use, abuse or force majeure.

This warranty gives you specific legal rights. Rights may vary depending on your state or province of residence. Some locations do not allow limitations on implied warranties or special incidental, or consequential damages, so the limitations may not apply to you. This limited warranty will be invalidated if the appliance is tampered with in any way whatsoever.

Our telephone helpline (888) 315-6553 is available for questions or technical assistance- Monday-Friday 9am to 5 pm EST.

Customers can also receive support via email: customerservice@chefman.com.

SAFETY INSTRUCTIONS

IMPORTANT SAFEGUARDS

THIS APPLIANCE IS FOR HOUSEHOLD USE ONLY. SAVE THESE INSTRUCTIONS

WARNING: When using electrical appliances, basic safety precautions should always be followed to reduce the risk of fire, electric shock, and/or injury to persons including the following:

- This appliance is intended for indoor home use only.
- Never use any accessories or parts from other manufacturers. Your warranty will become invalid if such accessories or parts have been used.
- Wash all removable parts with a mild cleanser before the first use.
- Check that your home power supply corresponds with this appliance's intended voltage.
- Place this appliance on a stable, heat resistant surface. Make sure not to place near or on a heat source such as gas or electric burner or oven.
- Before using this appliance, inspect the plug and cord line for cuts and/or abrasion marks. If they are found, do not use this appliance and contact our authorized customer service representative.
- During initial use, you may notice some smoke and or a slight odor. This is normal and should quickly dissipate. It should not reoccur after the appliance has been used a few more times.
- Always preheat for approximately 3 minutes.
- Before using your panini maker for the first time, wipe the cooking plates with a damp cloth to remove all dust, and then dry them. Never use abrasive scouring pads or cleaners on any part of the panini maker.
- This appliance should be used only by persons who are capable of understanding the user manual or are supervised by those who have adequate understanding of the appliances' features, their use, and the operating instructions. Children must be supervised and should not be left alone with appliances during their operation.
- During use appliances should not be left unattended.
- Care should be taken not to move appliances that are in use.
- **CAUTION:** this appliance generates heat during use. Proper precautions must be taken to prevent the risk of burns, fire or other damage to persons or property.
- Always preheat for approximately 3 minutes.

SAFETY INSTRUCTIONS

- Appliances can emit heat or steam when in use, therefore care should be taken not to block inlets or outlets.
- Do not use this appliance near an open flame or flammable materials.
- Before cleaning, make sure that the appliance is turned off, unplugged, and cooled to room temperature.
- Clean the housing of this appliance with a non-abrasive cleaner and a soft pad or cloth.
- Do not use alcohol as a cleaning product.
- Store unit in a cool, dry location.
- In case of any electric emergency such as a fire call 911.

SAVE THESE INSTRUCTIONS THIS APPLIANCE IS FOR HOUSEHOLD USE ONLY.

SHORT CORD INSTRUCTIONS

A short power supply cord is provided to reduce the hazards resulting from entanglement or tripping over a longer cord. Longer detachable power-supply cords or extension cords are available and may be used if care is exercised in their use. If a longer detachable power-supply extension cord is used:

1. The marked electrical rating of the cord set or extension cord should be at least as great as the electrical rating of the appliance, and:
2. The cord should be arranged so that it will not drape over the countertop or tabletop where it can be pulled on by children or tripped over unintentionally.

SAFETY INSTRUCTIONS

LINE CORD SAFETY TIPS

1. Never pull or yank on cord or the appliance.
2. To insert plug, grasp it firmly and guide it into outlet.
3. To disconnect appliance, grasp plug and remove it from outlet.
4. Before each use, inspect the line cord for cuts and/or abrasion marks. If any are found, this indicates that the appliance should be serviced and the line cord replaced. Please return it to an authorized service representative.
5. Never wrap the cord tightly around the appliance, as this could place undue stress on the cord where it enters the appliance and cause it to fray and break.

DO NOT OPERATE APPLIANCE IF THE LINE CORD SHOWS ANY DAMAGE OR IF APPLIANCE WORKS INTERMITTENTLY OR STOPS WORKING ENTIRELY.

CAUTION: To ensure continued protection against risk of electric shock, connect to properly grounded outlets only.

IMPORTANT: During the first few minutes of initial use, you may notice smoke and/or a slight odor. This is normal and should quickly disappear. It will not recur after appliance has been used a few more times.

This appliance is not intended for use by persons (including children) with reduced physical, sensory or mental capabilities, or lack of experience and knowledge, unless they have been given supervision or instruction concerning use of the appliance by a person responsible for their safety.

FEATURES

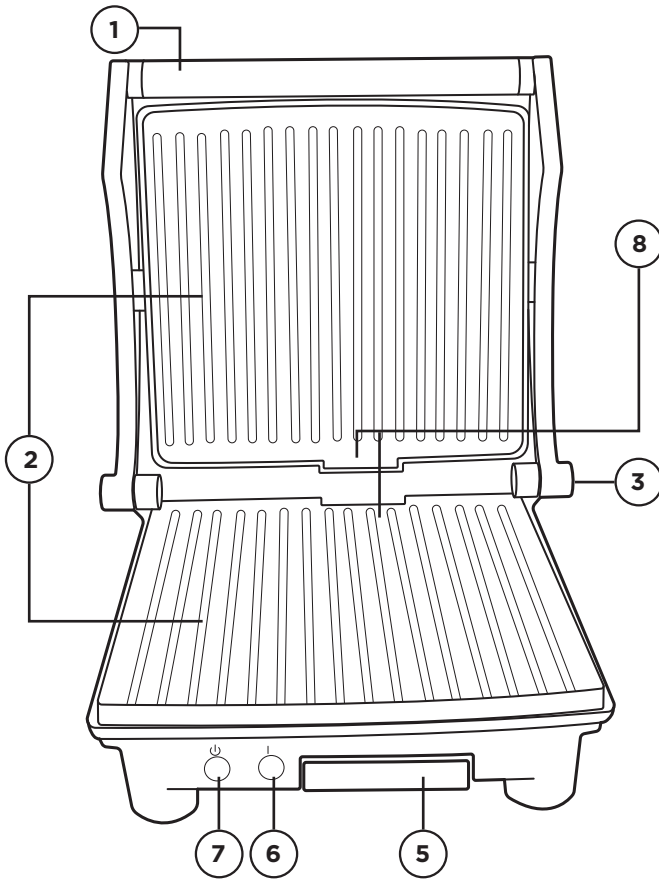

1. Handle
2. Non-stick grill plates
3. Lay-flat release button
4. Pull-out tilting Feet
5. Removeable drip tray
6. Ready light
7. Power light
8. Drip tray reservoir

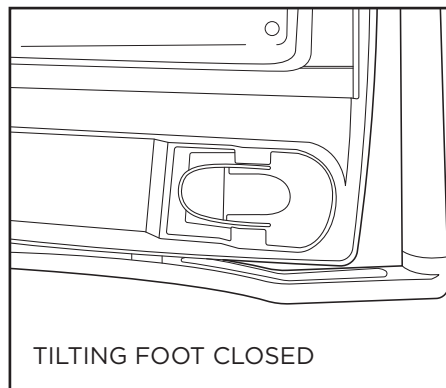
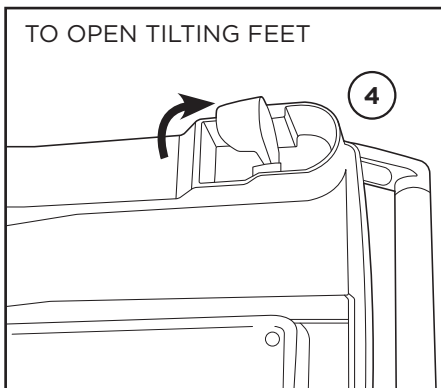

OPERATING INSTRUCTIONS

Using as a panini press in the closed position:

1. Always preheat the panini maker closed.
2. Before using the panini maker, use a pastry brush to lightly coat the top and bottom grilling plates with vegetable oil. This will help enhance the non-stick quality of the grill plates.

IMPORTANT: We recommend not to use non-stick sprays as they can cause build-up on the cooking plate.

3. Make sure that the removable drip tray is in the correct position before you use the panini maker.
4. The front two feet of the panini maker can be raised or lowered. Raising the feet will allow the grease to drain to the back of the appliance when grilling.
5. Adjust the feet by pressing the center tab of each foot. This will cause the foot to tilt into the upright position and it is now ready for use.
6. Preheat the panini maker for about 3 minutes. Keep the panini maker closed when preheating.
7. Check to make sure that the cord is fully unwrapped and ready to plug in an electrical outlet. The (POWER) light will illuminate and remain lit during use.
8. While preheating, prepare your food to be grilled.
9. After approximately 2 minutes, the green (READY) light will light up, indicating the appliance is preheated and ready for use.

NOTE: When the panini maker is heated for the first time, it may emit a slight smoke or odor; this is normal and should disappear after 2 or 3 uses. That does not affect the safety of the appliance.

NOTE: When cooking more than one panini side by side, try to make sure that each sandwich is similar in thickness. This will allow both to cook quickly, evenly, and grill well on both the top and bottom.

10. Place the panini sandwich centered on the bottom grill plate.
11. Close the handle and gently lower the top grill plate.
12. To ensure a perfectly grilled panini, make sure that the top grill plate lies evenly on the top of the bread and the sandwich is centered on the grill plate. If desired, press the handle down several times while cooking to press the sandwich and make it flatter.
13. During cooking, the green (READY) indicator light will cycle on/off during cooking. This indicates that the thermostat is maintaining the proper cooking temperature.
14. Continue grilling until the bread is toasted, and food is cooked to your liking.
15. To remove your grilled panini sandwiches, always use a heat safe plastic or wooden spatula as the grill becomes hot during cooking.

WARNING: never use a sharp edge or metal utensil as this can scratch the non-stick finish on the grill plates.

OPERATING INSTRUCTIONS

Using this as a grill in the open position:

The panini maker can be used in the open position to grill many types of food with ease.

1. Press the hinge button to create a completely flat contact grill. Wear protective oven mitts because the appliance will become hot. Grasp the handle and open the panini maker.
2. Follow the direction to raise the front tilt down feet. (See features on page 5). This will enable the grease to drain in the center of the flattened grill plates, and then into the drip tray.
3. When the grill plates are in an opened, flat position, it may be necessary to adjust the angle of the upper grill plate. Press the grill plate down on the upper plate's drip tray reservoir to adjust the angle (See figure 1).

CAUTION: Always wear protective oven mitts when touching a hot surface.

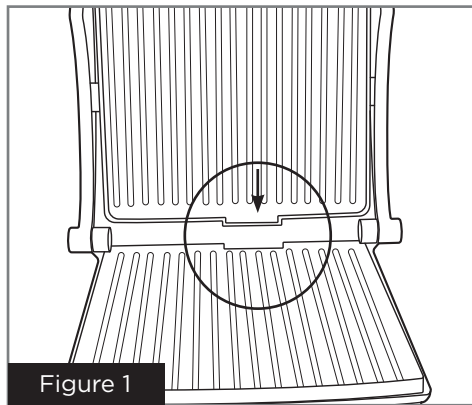

Figure 1

4. Preheat the grill to produce the best grilled results.
5. The green (READY) light will cycle on and off as the grill maintains cooking temperatures.
6. Follow your recipe for the optimum cooking time and doneness for each of your grilled foods.
7. Note the perfect grill times for each food for future cooking reference.
8. Wearing oven mitts, remove grilled food from the cooking plate(s). Use a non-metallic utensil to avoid scratching the non-stick finish. A plastic heat safe spatula will help to remove delicate food in one piece. Plastic heat safe tongs are helpful when grilling meat or sausages.

NOTE: When grilling more than one piece of food, it is best to use foods that are consistent in size and thickness.

CLEANING AND MAINTENANCE

- Disconnect the panini press from the electrical outlet and make sure that it has cooled to room temperature.
- Wipe the grill surface with a soft damp cloth to remove grease or left over food. Use a heat safe plastic or wooden cooking utensil to remove cooked on food residue. Never use steel wool or abrasive cleaning pads to remove food residue.
- Use a damp cloth or non-abrasive sponge with a small amount of non-abrasive dish-washing liquid to clean the cooking surfaces of the grill.
- With a soft dry cloth dry the inside and outside of the panini press. Do not immerse this product in any liquid.
- Close the plastic feet on this grill before storing this item.
- Store in a dry, cool place.

TIPS AND TRICKS

Panini Pizazz!

1. Using your panini press wisely — Your panini press allows you to control the cooking time, pressure and level of crispiness of your sandwich. Personal preference is what determines your combination.
2. Experiment with a variety of breads and fillings — You can make sweet or savory sandwiches based on your choice of fillings. You can use all types of breads such as: bagels, biscuits, brioche, challah, white, rolls, rye, sourdough, multigrain, pita etc.
3. Add some crunch — Make the most of your sandwich by using olive oil, butter or cooking sprays on the outside of your panini to create a more crispy and flavorful sandwich.
4. Remember that the crispiness of your sandwich will change if you use fillings with a lot of moisture. You can add breadcrumbs to the more moist fillings to absorb the excess liquid.
5. If you are using rounded breads like baguettes you may want to flip them inside out so that the flat surface of the bread contacts the grill.
6. If you enjoy greens like lettuce and do not want them to wilt as you grill, add them at the end or right before serving.

Terms & Conditions

Limited Warranty

CHEFMAN® LLC warrants, subject to the conditions stated below, that from the date of purchase, this product will be free from mechanical defects for a period of ONE (1) year. CHEFMAN® LLC, at its option, will repair or replace this product found to be defective during the warranty period. Should this product become defective by reason of improper workmanship or material defect during the specified warranty period, CHEFMAN® LLC will repair or replace the same effecting all necessary parts replacements for a period of one year from the date of purchase. If product is no longer available we will replace it with a product of equal value. Transportation charges on parts, or products in whole, submitted for repair or replacement, under this warranty, must be borne by the purchaser. This warranty is void if the product is used for other than single-family household use or subjected to any voltage and waveform other than as specified on the rating label (e.g., 120V - 60 Hz).

This warranty is available to consumers only. You are a consumer if you own a CHEFMAN® product that was purchased at retail for personal, family or household use. Except as otherwise required under applicable law, this warranty is not available to retailers or other commercial purchasers or owners.

CONDITIONS: This warranty is valid for the original USA and Canada retail purchaser from the date of initial retail purchase and is not transferable. Keep the original sales receipt. Proof of purchase is required to obtain warranty service or replacement. Dealers, service centers, or retail stores do not have the right to alter, modify or in any way, change the terms and conditions of this warranty. Warranty registration is not necessary to obtain warranty on CHEFMAN® LLC Products. Save your proof of purchase receipt.

ABOUT YOUR PRODUCT WARRANTY: Most warranty repairs are handled routinely, but sometimes requests for warranty service may not be appropriate. For example, warranty service would NOT apply if the product damage occurred because of misuse, lack of routine maintenance, shipping, handling, 3rd party warehousing or improper installation. Similarly, the warranty is void if the manufacturing date or the serial number on the product has been removed or the equipment has been altered or modified. During the warranty period, the authorized service dealer, at its option, will repair or replace any part that, upon examination, is found to be defective under normal use and service.

NORMAL WEAR: This warranty does not cover normal wear of parts or damage resulting from any of the following: negligent use or misuse of the product; improper voltage or current; use contrary to the operation instructions; deviation from instructions regarding storage and transportation; repair or alteration by anyone other than CHEFMAN® LLC or an authorized service center. Further, the warranty does not cover Acts of God, such as fire, flood, hurricanes and tornadoes. CHEFMAN® LLC shall not be liable for any incidental or consequential damages caused by the breach of any express or implied warranty. Except to the extent prohibited by applicable law, any implied warranty of merchantability or fitness for a particular purpose is limited in duration to the duration of the above warranty. Some states, provinces or jurisdictions do not allow the exclusion or limitation of incidental or consequential damages or limitations on how long an implied warranty lasts, so the above limitations or exclusion may not apply to you. This warranty gives you specific legal rights, and you may also have other rights that vary from state to state or province to province.

HOW TO OBTAIN WARRANTY SERVICE: If your CHEFMAN® product should prove to be defective within the warranty period, we will repair it, or if we think necessary, replace it. To obtain warranty service, simply email customerservice@chefman.com or call our toll-free number 1-888-315-6553 for additional information from our Customer Service Representatives, or send the defective product to Customer Service at Chefman, 1 Sharp Plaza, Mahwah, NJ 07495.

This warranty is effective for the time periods listed above and subject to the conditions provided for within this policy.

CALIFORNIA RESIDENTS ONLY:

California law provides that for In-Warranty Service, California residents have the option of returning a nonconforming product (A) to the store where it was purchased or (B) to another retail store which sells CHEFMAN® products of the same type. The retail store shall then, at its discretion, either repair the product, refer the consumer to an independent repair facility, replace the product, or refund the purchase price less the amount directly attributable to the consumer's prior usage of the product. If the above two options do not result in the appropriate relief to the consumer, the consumer may then take the product to an independent repair facility if service or repair can be economically accomplished. CHEFMAN® and not the consumer will be responsible for the reasonable cost of such service, repair, replacement, or refund for nonconforming products under warranty.

CHEFMAN® is a registered trademark of RJ BRANDS, LLC.

Warranty



MULTI-FUNCTIONAL

180° GRILL+ PANINI PRESS



All data fields are required in order for us to process your request:

Model Number: _____

Full Name: _____

Address: _____

Phone: _____ Email: (if applicable) _____

Date of Purchase*: _____

*We recommend you keep the receipt with this warranty card

Retail Store of Purchase: _____

Description of Malfunction:

Return your completed warranty card to:

RJ Brands
1 Sharp Plaza
Suite 207
Mahwah, NJ
07495

MULTI-FUNCTIONAL

180° GRILL+
PANINI PRESS

MODEL:
RJ02-180-4

888.315.6553

customerservice@chefman.com

Phone lines available Monday to Friday, 9am-5pm EST

1-YEAR LIMITED WARRANTY



To log-in to ClubChefman.com follow the below steps:

1. Enter www.clubchefman.com into your web browser.
2. Click on "Sign Up Now".
3. Fill in the required information as prompted.
NOTE: "Place of Purchase" refers to the store at which you purchased your product.
4. Sign in using your User Name and Password.

CLUB CHEFMAN ACCESS CODE: 2131716

CHEFMAN



RJBRANDS.COM | CLUBCHEFMAN.COM | CHEFMAN.COM