



EN ■ Multi-purpose Contact Grill

READ CAREFULLY AND STORE FOR FUTURE USE.

- This appliance may be used by children 8 years of age and older and by persons with physical or mental impairments or by inexperienced persons, if they are properly supervised or have been informed about how to use the product in a safe manner and understand the potential dangers. Cleaning and maintenance performed by the user must not be performed by children unless they are older than 8 years of age and under supervision. Keep this appliance and the power cord out of reach of children that are younger than 8 years of age. Children must not play with the appliance.
- Before connecting the appliance to a power socket, check that the rated voltage stated on the appliance's rating label matches the electrical voltage in the socket to which you wish to connect the appliance.
- Connect the appliance only to a properly grounded socket.



Attention:

This appliance is not designed to be controlled using a programmed device, external timer switch or remote control.

- The appliance is designed for household use only. It is not intended for use in locations such as:
 - staff kitchens in stores, offices and other workplaces;
 - hotel or motel rooms and other living areas;
 - agricultural farms;
 - bed and breakfast establishments.
- Do not use the appliance in an industrial environment or outdoors or for purposes other than those for which it is intended.
- Do not place the appliance on window sills, kitchen sink drainboards or unstable surfaces. Always place it on a stable, even and dry surface.
- Do not place the appliance on an electric or gas stove or in its vicinity, do not place it in the vicinity of an open fire or an appliance that is a source of heat.
- To prevent potential injury by electrical shock, do not submerge any part of the appliance in water or any other liquid.
- Do not use the appliance without the slide-in drip tray and without the grill/griddle plates installed.
- During operation there needs to be sufficient area for air circulation above the appliance and on all its sides. Do not use the appliance near flammable materials such as curtains, kitchen towels, etc.



Attention: Hot surface

- The temperature of accessible surfaces may be higher if the appliance is in operation. Take care not to touch the hot outer case or the surface of the grill plates. Use the handle to tilt open the top griddle plate.
- Always turn off the appliance and disconnect it from the power socket when leaving it without supervision, after finishing using it and before cleaning or moving it.
- Allow the appliance to fully cool down before moving, cleaning or storing it.
- Clean the surface of the grill plates after each use, as described in chapter Maintenance and cleaning.
- Disconnect the power cord from the power socket by pulling on the plug, never pulling on the cord. Otherwise, this could damage the power cord or the socket.
- Make sure the power cord does not hang over the edge of a table and that it is not touching a hot surface.
- In the event that the power cord is damaged, have it repaired at a professional service centre to prevent causing a dangerous situation. It is forbidden to use the appliance if it has a damaged power cord.
- To avoid the danger of injury by electrical shock, do not repair the appliance yourself or make any adjustments to it. Have all repairs performed at an authorised service centre. By tampering with the appliance, you risk voiding your legal rights arising from unsatisfactory performance or quality warranty.

A

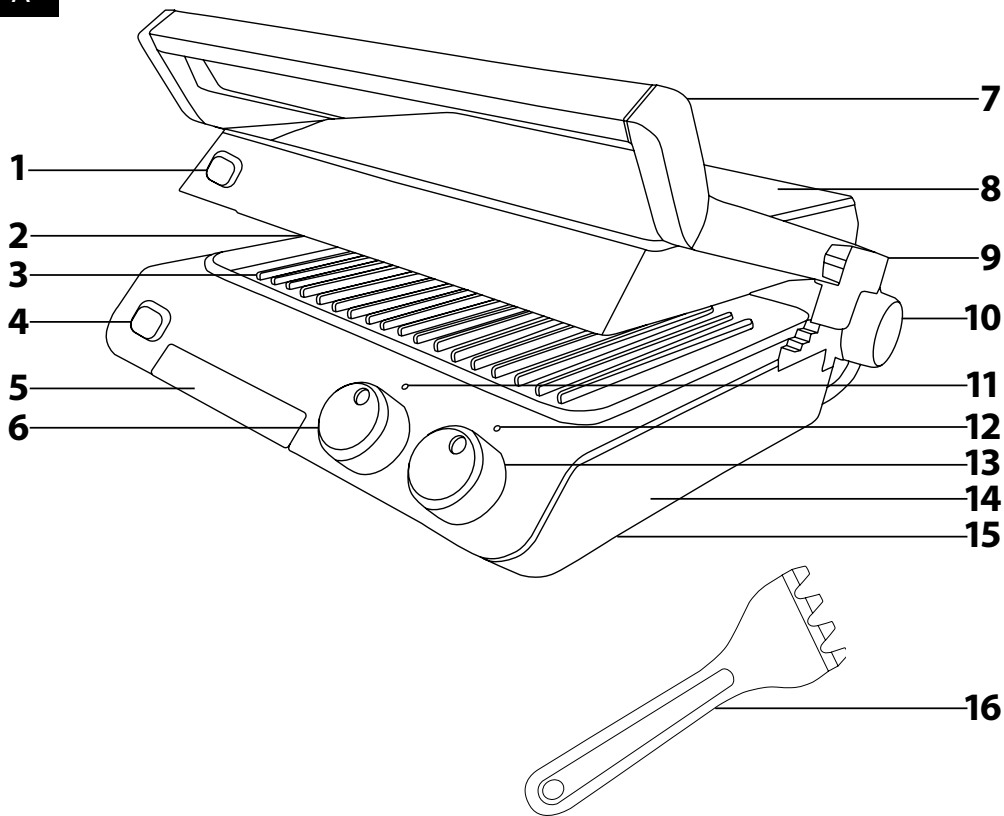

- Prior to using this appliance, please read the user's manual thoroughly, even if you already have experience in using similar appliances. Only use the appliance in the manner described in this user's manual. Keep this user's manual in a safe place where it can be easily retrieved for future use.
- We recommend saving the original cardboard box, packaging material, purchase receipt and responsibility statement of the vendor or warranty card for at least the duration of the legal liability for unsatisfactory performance or quality. In the event of transportation, we recommend that you pack the appliance in the original box from the manufacturer.

DESCRIPTION OF THE CONTACT GRILL

- A1** Top griddle plate release button
- A2** Removable top griddle plate
- A3** Removable bottom grill plate
- A4** Bottom grill plate release button
- A5** Removable drip tray
- A6** 30-minute timer
- A7** Handle for carrying and tilting open the top plate
- A8** Top griddle plate cover
- A9** Sliding lock for locking and unlocking the grill plates and setting the height of the top griddle plate
- A10** Top plate hinge lock release button
- A11** Timer setting indicator
- A12** Heating grill plates indicator
- A13** Temperature control knob with a range of 80–240 °C
- A14** Base unit
- A15** Power cord storage space
- A16** Scraper

REMOVING AND ATTACHING THE GRILL PLATES

- Prior to removing or attaching the grill plates, check that the grill is turned off, disconnected from the power socket and has cooled down.
- To attach or insert a grill plate, it is necessary to slide the lock **A9** to the "OPEN" position and to use the handle **A7** to tilt open the top plate **A2** into the vertical position.
- To remove the top plate **A2**, use one hand to push and hold down button **A1**, and the other to remove the plate **A2**. After removing it, release button **A1**. To remove the bottom grill plate **A3**, use one hand to push and hold down button **A4**, and the other to remove the plate **A3**. After removing it, release button **A4**.
- To attach, insert the top plate **A2** into the top cover **A8** so that the cut outs at the rear of the plate **A2** slide on to the tabs at the rear of the cover **A8**. Then push the plate **A2** against the cover **A8**, so that the tab under the grill plate **A2** slides into the hole in the cover **A8**. Attach the bottom plate **A3** to the base unit **A14** in the same way.

LOCKING AND UNLOCKING THE GRILL PLATES AND SETTING THE HEIGHT OF THE TOP GRIDDLE PLATE

- When the top griddle plate **A2** is tilted down on to the bottom grill plate **A3** and the lock **A9** is set in the "LOCK" position, the grill plates are locked together. This setting is intended for carrying the grill in the vertical position and for storing the grill in the vertical position.
- To release the top griddle plate **A2**, slide the lock **A9** to the "OPEN" position. Now the top griddle plate **A2** can be tilted open all the way to the vertical position.
- Setting the sliding lock **A9** to position 1 to 5 adjusts the height of the top griddle plate **A2**, i.e. the distance of the top griddle plate **A2** from the bottom grill plate **A3**. Height adjustment is suitable for grilling fish, hamburgers, vegetables, toasted sandwiches and cooking other delicate foods where it is undesirable for the top griddle plate **A2** to compress the food with its full weight. When setting the height, it is necessary to lift and hold the top griddle plate **A2** above the bottom grill plate **A3**. To lift and hold the griddle plate **A2**, use the handle **A7**.
- To tilt open the top griddle plate **A2** so that it is level with the bottom grill plate **A3**, hold down button **A10** while at the same time tilting open the top griddle plate **A2** so that the handle **A7** is resting on the tabletop or kitchen countertop. This will double the grilling area. After tilting open the top griddle plate **A2**, release button **A10**.

NON-STICK COATING ON THE GRILL PLATES

- The grill plates on your contact grill have a special non-stick surface coating. This coating enables you to prepare healthy meals while using a minimum amount of fat or oil.
- For placing food on the grill or removing it, use only heat-resistant wooden, plastic or silicone kitchen utensils.
- Do not use sharp or metal kitchen utensils and do not cut the food directly on the grill plate. The manufacturer takes no responsibility for damage to the coating caused by the use of sharp objects or metal utensils.
- Any discolouration of the surface of the grill plates affects only appearance, not functionality.

BEFORE FIRST USE

- Before first use, remove the contact grill from the packaging material and remove all promotional materials including labels located on the grill/griddle plates. Wipe the griddle plate **A2** and grill plate **A3** with a clean dampened cloth and then wipe dry. Take the removable drip tray **A5** and wash it in warm water using a neutral kitchen detergent. Then rinse it under clean running water, wipe it dry and put it back in its place.
- Wash the scraper **A16** in warm water using a neutral kitchen detergent. Then rinse it under clean running water and wipe it dry.
- The griddle/grill plates **A2** and **A3**, the removable drip tray **A5** and the scraper **A16** can also be washed in a dishwasher (in the upper rack).

- Do not rinse or submerge the grill or its power cord in water or any other liquids.
- Before first use, run the grill empty for 10 minutes with the temperature control knob **A13** set to the maximum grilling temperature. Then turn the grill off, disconnect it from the power socket and allow it to cool down.



Note:

When first turned on, a small amount of smoke may be emitted. This is a completely normal event.

USING THE CONTACT GRILL

- Before every use, we recommend to apply a thin layer of high-temperature cooking oil on to the griddle/grill plates **A2** and **A3**.
- Check that the removable drip tray **A5** is properly inserted all the way into the base unit **A14** and that the griddle/grill plates **A2** and **A3** are installed in their place. Check that the timer and temperature control knob are set in the off position, and connect the grill to a power socket.
- If the griddle/grill plates are locked together, release them by setting the lock **A9** to the "OPEN" position. Allow the grill to heat up by setting timer **A6** to 5 minutes and the temperature control knob **A13** to position 4 – "SUPER HIGH" (maximum temperature). To heat up faster, leave the griddle plate **A2** tilted down. When the timer **A6** is set, indicator **A11** will be lit. Heating of the grill plates to the set temperature is signalled by indicator **A12**. At the end of the set time a sound is made and the grill turns off automatically. Indicator **A11** will dim and indicator **A12** will turn off completely.
- After preheating the grill plates, set the desired time using the timer **A6**, and set the temperature control knob **A13** based on the type of food that you are grilling. The timer **A6** can be set in 5-minute intervals in the range from 0 to 30 minutes. The temperature control knob **A13** can be used to set four different temperature levels.

TEMPERATURE CONTROL KNOB SETTINGS	TEMPERATURE
0	off
1 – "LOW" (low temperature)	80–120 °C
2 – "MED" (medium temperature)	120–160 °C
3 – "HIGH" (high temperature)	160–200 °C
4 – "SUPER HIGH" (maximum temperature)	200–240 °C

- The timer **A6** counts down the set time and the temperature control knob **A13** displays the selected temperature level. The temperature can be adjusted as required while grilling.

Grilling with the top plate tilted down

- Tilt open the top plate **A2** so that it is in a vertical position. Use the handle **A7** to tilt out the plate. Place meat, vegetables, a sandwich or other food that you wish to grill or bake in on to the bottom plate **A3**. Use the handle **A7** to tilt down the top plate **A2**. Regularly check on the condition of the meat while grilling. If you do not wish the top plate **A2** to lie on the food, adjust its height as described in chapter Locking and unlocking the grill plates and setting the height of the top griddle plate.

Grilling on an open grill

- The unique design of the contact grill enables both grilling surfaces to be used at the same time. Tilt open the top griddle plate **A2** so that it is level with the bottom grill plate **A3** as described in chapter Locking and unlocking the grill plates and setting the height of the top griddle plate.
- Place meat, vegetables or other food suitable for grilling on to the grill plates. Turn the food over as required while grilling.



Note:

The grill plate heating indicator **A12** turns on and off intermittently during operation. This signals that the set temperature is being maintained.

- At the end of the set time a sound is made and the grill turns off automatically. Indicator **A11** will dim and indicator **A12** will turn off completely. Set the temperature control knob **A13** to position 0 (off).
- Remove the cooked meal from the grill plate. For this purpose, use heat-resistant wooden, silicone or plastic kitchen utensils. Do not use metal tongs, metal spatulas, knives or other sharp metal kitchen utensils. This could cause damage to the non-stick coating of the grill plates.
- After you have finished using the appliance, ensure that the timer and temperature control knob are set to position 0 (off), and that the power cord is disconnected from the power socket. Allow the grill to cool down before handling it again in any way.

TIPS FOR GRILLING MEAT

- To achieve optimal results, cut meat into slices to a thickness where the top griddle plate rests on them when tilted down.
- We do not recommend using the contact grill for grilling meat with thick bones, such as bone-in pork chops.
- Do not salt the meat before grilling. This would result in the meat being tough and dry.
- Before grilling marinated meat, pat it down with paper towels to remove excess marinade. Some marinades have a high sugar content, which may burn on to the grill plates.
- Do not avoid juices from escaping, do not puncture the meat with a knife or fork. Otherwise the meat will be tough and dry.
- Do not dry out the meat by grilling it for too long.
- Always make sure that chicken meat is thoroughly cooked.
- When the meat has finished grilling, season it with salt or other seasoning.
- You do not have to prick pre-cooked hot dogs before grilling them.

RECOMMENDED TEMPERATURE AND TIME SETTINGS

FOOD TYPE	TEMPERATURE CONTROL KNOB SETTINGS	GRILLING TIME (WITH THE TOP PLATE TILTED DOWN)
Beef • sirloin of beef	3 – HIGH (high temperature)	4 minutes (medium) 5–6 minutes (well done)
• steak as a fast meal • hamburgers	3 – HIGH (high temperature) 3 – HIGH (high temperature)	5–8 minutes 8–10 minutes
Pork • medallions from pork tenderloin • slices (schnitzels) • neck of pork slices	3 – HIGH (high temperature) 3 – HIGH (high temperature) 3 – HIGH (high temperature)	4–6 minutes 7–8 minutes 9–10 minutes
Lamb • tenderloin • slices • steaks from leg of lamb	3 – HIGH (high temperature) 3 – HIGH (high temperature) 3 – HIGH (high temperature)	6 minutes 8 minutes 8 minutes
Chicken • breast fillets • thigh fillets	3 – HIGH (high temperature) 3 – HIGH (high temperature)	6 minutes or more, until they are well cooked 4–5 minutes or more, until they are well cooked
Sausages / hot dogs • thin • thicker	2 – MED (medium temperature) 2 – MED (medium temperature)	5–6 minutes 7–8 minutes
Seafood • skinless fish fillets • fish fillets with skin on • octopus (cleaned) • prawns	4 – SUPER HIGH (maximum temperature) 4 – SUPER HIGH (maximum temperature) 3 – HIGH (high temperature) 3 – HIGH (high temperature)	8–10 minutes 10–12 minutes 8 minutes 5 minutes
Sandwich or focaccia	2 – MED (medium temperature)	5–6 minutes
Vegetables sliced into 2 cm thick slices • eggplant • zucchini • sweet potatoes	2 – MED (medium temperature) 2 – MED (medium temperature) 2 – MED (medium temperature)	8–10 minutes 8–10 minutes 8–10 minutes



Note:
The temperature control knob settings **A13** indicated above serve only as a reference and may differ depending on the thickness of the meat slices or food size.

MAINTENANCE AND CLEANING

- Before cleaning it, make sure that the grill is turned off, disconnected from the power socket and that it has cooled down.
- Clean the surface of the grill plates after every use to prevent the formation of layers of charred food remains.
- First use the scraper **A16** to clean food remains from the ribbed grill plate **A3**. Then clean the grill plates **A2** and **A3** using a dampened, fine textile. If you are unable to remove charred food remains, e.g. from marinated meat, apply a weak solution of water and neutral kitchen detergent. After applying the kitchen detergent, thoroughly wipe the grill plates with a clean damp cloth.



Note:
It will be easier to clean the grill plates **A2** and **A3** while they are still slightly warm.

- After every use, rinse out and wash the drip tray **A5** in warm water with neutral dishwashing detergent. Then rinse it with clean water, dry it and place it back into the underside of the grill.
- Wash the scraper **A16** in warm water using a neutral kitchen detergent. Then rinse it under clean running water and wipe it dry.
- The griddle/grill plates **A2** and **A3**, the removable drip tray **A5** and the scraper **A16** can also be washed in a dishwasher (in the upper rack).
- To clean the outer surface, use a dry or a slightly dampened cloth and then wipe the surface of the grill until dry.
- To clean the contact grill and its parts, do not use steel wool, abrasive cleaning products, petrol, etc. Do not rinse or submerge the grill or its power cord in water or any other liquids.

STORAGE

- When the contact grill plates have cooled down, tilt the top griddle plate **A2** down on the bottom grill plate **A3** and lock them together by sliding the lock **A9** to position "LOCK". Wind the power cord into the storage space **A15** at the bottom of the grill. Store the grill in a clean, dry place that is out of reach of children.

TECHNICAL SPECIFICATIONS

Rated voltage 220–240 V
 Rated frequency 50/60 Hz
 Rated power input 2 000 W

We reserve the right to change text and technical specifications.

INSTRUCTIONS AND INFORMATION REGARDING THE DISPOSAL OF USED PACKAGING MATERIALS

Dispose of used packaging material at a site designated for waste in your municipality.

DISPOSAL OF USED ELECTRICAL AND ELECTRONIC EQUIPMENT



This symbol on products or original documents means that used electric or electronic products must not be added to ordinary municipal waste. For proper disposal, renewal and recycling hand over these appliances to determined collection points. Alternatively, in some European Union states or other European countries you may return your appliances to the local retailer when buying an equivalent new appliance.



Correct disposal of this product helps save valuable natural resources and prevents potential negative effects on the environment and human health, which could result from improper waste disposal. Ask your local authorities or collection facility for more details.

In accordance with national regulations penalties may be imposed for the incorrect disposal of this type of waste.

For business entities in European Union states

If you want to dispose of electric or electronic appliances, ask your retailer or supplier for the necessary information.

Disposal in other countries outside the European Union.

This symbol is valid in the European Union. If you wish to dispose of this product, request the necessary information about the correct disposal method from the local council or from your retailer.



This product meets all the basic requirements of EU directives related to it.