

Infinite WaterColors™ LED Light Controller

This product requires AquaLink® RS revision Y or later
or AquaLink EDGE

Essential installation and startup instructions are included in this manual.
Additional operation and troubleshooting information is available online
by scanning the QR code with your phone or visiting jandy.com



WARNING

FOR YOUR SAFETY – This product must be installed and serviced by a contractor who is licensed and qualified in pool equipment by the jurisdiction in which the product will be installed where such state or local requirements exist. The maintainer must be a professional with sufficient experience in pool equipment installation and maintenance so that all of the instructions in this manual can be followed exactly. Before installing this product, read and follow all warning notices and instructions that accompany this product. Failure to follow warning notices and instructions may result in property damage, personal injury, or death. Improper installation and/or operation may void the warranty.

Improper installation and/or operation can create unwanted electrical hazard which may cause serious injury, property damage, or death.



ATTENTION INSTALLER – This manual contains important information about the installation, operation and safe use of this product. This information should be given to the owner/operator of this equipment.

Table of Contents

Section 1. Important Safety Instructions 3	3.4 Low Voltage Wiring and Communication 9
1.1 Safety Instructions 3	3.5 RS-485 Wiring and Communication 9
1.2 Landscape Lighting Instructions 4	3.6 Bonding 10
1.3 Specifications 5	
Section 2. Best Installation Practices 5	Section 4. Connecting to Automation 11
Section 3. Installation 8	4.1 Connected to AquaLink RS 11
3.1 Location Requirements for Pool and Spa Light Applications 8	4.2 Connected to AquaLink EDGE 12
3.2 Mounting 8	Section 5. Additional Online Content 12
3.3 High Voltage Wiring 8	Section 6. Troubleshooting 13

FCC Regulatory Compliance Statement

This device complies with Part 15 of the FCC Rules. Operation is subject to the following two conditions:

1. This device may not cause harmful interference, and
2. This device must accept any interference received, including interference that may cause undesired operation.

 CAUTION
Changes or modifications not expressly approved by the party responsible for compliance could void the user's authority to operate the equipment.

NOTE: This equipment has been tested and found to comply with the limits for a Class B digital device, pursuant to Part 15 of the FCC Rules. These limits are designed to provide reasonable protection against harmful interference in a residential installation. This equipment generates, uses and can radiate radio frequency energy and, if not installed and used in accordance with the instructions, may cause harmful interference to radio communications. However, there is no guarantee that interference will not occur in a particular installation. If this equipment does cause harmful interference to radio or television reception which can be determined by turning the equipment off and on, the user is encouraged to try to correct the interference by one or more of the following measures:

- Reorient or relocate the receiving antenna.
- Increase the separation between the equipment and receiver.
- Connect the equipment into an outlet on a circuit different from that to which the receiver is connected.
- Consult the dealer or an experienced radio/TV technician for help.

This device must be installed to provide a separation distance of at least 20cm from all persons and must not be collocated or operating in conjunction with any other antenna or transmitter, except in accordance with FCC multi-transmitter product guidelines.

ISED Canada Regulatory Compliance Statement

This device contains licence-exempt transmitter(s)/receiver(s) that comply with Innovation, Science and Economic Development Canada's licence-exempt RSS(s). Operation is subject to the following two conditions:

1. This device may not cause interference.
2. This device must accept any interference, including interference that may cause undesired operation of the device.

This radio transmitter IC:10837A-WT000354 has been approved by Innovation, Science and Economic Development Canada to operate with the antenna types listed below, with the maximum permissible gain indicated. Antenna types not included in this list that have a gain greater than maximum gain indicated for any type listed are strictly prohibited for use with this device.

Antenna	Type	Input impedance	Gain
AANE-WH-0209	Rod Antenna	50Ω	2.4 dBi
W1038x	Rod Antenna	50Ω	4.71 dBi

This device complies with ISED radiation exposure limits set forth for an uncontrolled environment. This equipment should be installed and operated with minimum distance 20cm between the radiator and your body. This transmitter must not be collocated or operating in conjunction with any other antenna or transmitter.



Section 1. Important Safety Instructions

IMPORTANT SAFETY INSTRUCTIONS READ AND FOLLOW ALL INSTRUCTIONS

1.1 Safety Instructions

All electrical work must be performed by a licensed electrician and conform to all national, state, provincial and local codes. When installing and using this electrical equipment, basic safety precautions should always be followed, including the following:

WARNING

EQUIPMENT UNDER PRESSURE: Always turn pump off prior to installation or service. Your pump/filter system is operated under pressure and the pressure must be released before you begin work. Please see your pump/filter owner's manual for further instructions.

To reduce the risk of electric shock, fire or injury, service should only be attempted by a qualified pool service professional.

RISK OF ELECTRIC SHOCK: When installed as a power source for landscape lighting: Install power unit 5 feet (1.5 m) or more from a pool or spa and 10 feet (3.05 m) or more from a fountain. Where the power unit is installed within 10 feet (3.05 m) of a pool or spa connect power unit to a GFCI protected branch circuit. Canadian installations must be at least three (3) meters from the water.

RISK OF ELECTRIC SHOCK WHICH CAN RESULT IN SERIOUS INJURY OR DEATH: Before attempting to install or service, ensure that all power to the circuit supplying power to the system is disconnected or turned off at the circuit breaker. All wiring must be done in accordance with the National Electrical Code® (NEC)®, NFPA-70®, including those in Article 680 - Swimming Pools, Fountains, and Similar Installations.

In Canada, the Canadian Electrical Code (CEC), CSA C22.1, must be followed. All applicable local installation codes and regulations must be followed.

ATTENTION

This power center and the chlorine generator control center are not to be considered as suitable for use as service equipment. Therefore, it is required to have the appropriate means of disconnection, circuit isolation, and/or branch circuit protection installed upstream of the power/control center.

WARNING

To reduce the risk of injury do not permit children to use this product unless they are closely supervised at all times.

Risk of Accidental Drowning. Extreme caution must be exercised to prevent unauthorized access by children. To avoid accidents, ensure that children cannot use a spa or hot tub unless they are closely supervised at all times

This appliance is not intended for use by persons (including children) with reduced physical, sensory or mental capabilities, or lack of experience and knowledge, unless they have been given supervision or instruction concerning use of the appliance by a person responsible for their safety.

PREVENT CHILD DROWNING: Do not let anyone, especially small children, sit, step, lean or climb on any equipment installed as part of your pool's operational system. Locate the components of your operational system at least 1 m 3.3 feet (1 m) from the pool so children cannot use the equipment to access the pool and be injured or drown.

To reduce the risk of injury, do not remove the suction fittings of your spa or hot tub. Never operate a spa or hot tub if the suction fittings are broken or missing. Never replace a suction fitting with one rated less than the flow rate marked on the equipment assembly.

A terminal bar marked "GROUND" is provided within the power center. To reduce the risk of electrical shock, connect this terminal bar to the grounding terminal of your electric service or supply panel with a continuous copper conductor having green insulation and one that is equivalent in size to the circuit conductors supplying this equipment, but no smaller than no. 12 AWG (3.3 mm²). In addition, a second wire connector should be bonded with a no. 8 AWG (8.4 mm²) copper wire to any metal ladders, water pipes, or other metal within five 5 feet (1.5 m) of the pool/spa. In Canada, the bonding wire must be minimum 6 AWG (13.3 mm²).

Install only on a branch circuit protected by a ground fault circuit interrupter (GFCI), Class A GFCI in Canada. The conductors on the load side of the ground-fault circuit-interrupter shall not occupy conduit, boxes, or enclosures containing other conductors unless the additional conductors are also protected by a ground-fault circuit-interrupter. Refer to local codes for complete details.

⚠ CAUTION

This device is intended for use with permanent swimming pools and may also be used with hot tubs and spas if so marked. Do not use with storable pools. A permanently-installed pool is constructed in or on the ground or in a building such that it cannot be readily disassembled for storage. A storable pool is constructed so that it is capable of being readily disassembled for storage and reassembled to its original integrity.

Modifications made to this equipment, which are not authorized by the manufacturer, may void the user's authority to operate this equipment.

⚠ WARNING

To reduce the risk of FIRE OR INJURY TO PERSONS: Turn off/unplug and allow to cool before replacing lamp.

LAMP GETS HOT QUICKLY! Contact only switch/plug when turning on. Do not touch hot lens, guard, or enclosure (see diagram/picture). Keep lamp away from materials that may burn. Do not touch the lamp at any time. Use a soft cloth. Oil from skin may damage lamp. Do not operate the luminaire fitting with a missing or damaged shield. **LIGHTED LAMP IS HOT!**

SAVE THESE INSTRUCTIONS

1.2 Landscape Lighting Instructions

THIS SECTION INCLUDES INSTRUCTIONS, PRECAUTIONS AND WARNINGS APPLICABLE TO LANDSCAPE LIGHTING APPLICATIONS. FOLLOW ALL REQUIREMENTS OF THIS SECTION WHEN LIGHT CONTROLLER IS USED IN LANDSCAPE LIGHTING APPLICATIONS.

⚠ CAUTION

For use only on a branch circuit protected by a ground fault circuit interrupter (GFCI), Class A GFCI in Canada.

⚠ WARNING

RISK OF ELECTRICAL SHOCK. Install power unit 5 feet (1.5 m) or more from a pool or spa and 10 feet (3.05 m) or more from a fountain. Where the power unit is installed within 10 feet (3.05 m) of a pool or spa connect power unit to a GFCI protected branch circuit. In Canada, do not mount power supply or landscape luminaires within 10 feet (3.05 m) of a swimming pool or spa or fountain.

THIS DEVICE IS ACCEPTED AS A COMPONENT OF A LANDSCAPE LIGHTING SYSTEM WHERE THE SUITABILITY OF THE COMBINATION SHALL BE DETERMINED BY CSA OR LOCAL INSPECTION AUTHORITIES HAVING JURISDICTION

- IN CANADA, LANDSCAPE LIGHTING POWER SUPPLIES ARE FOR OUTDOOR USE ONLY. MOUNT AT LEAST 30 CM ABOVE GROUND.
- THIS DEVICE IS CERTIFIED FOR USE WITH LANDSCAPE LIGHTING SYSTEMS. THIS DEVICE IS ACCEPTED AS A COMPONENT OF A LANDSCAPE LIGHTING SYSTEM WHERE THE SUITABILITY OF THE COMBINATION SHALL BE DETERMINED BY CSA OR LOCAL INSPECTION AUTHORITIES HAVING JURISDICTION.
- DO NOT CONNECT TWO OR MORE POWER SUPPLIES IN PARALLEL.
- LANDSCAPE LIGHTING SYSTEMS ARE FOR OUTDOOR USE ONLY. NOT FOR USE IN DWELLING UNITS.

1.3 Specifications

Power Supply	
Input:	120VAC, 60 Hz, 2.75A
Output:	14 VAC, 60 Hz, max 300W
Enclosure: Type 3RX	
Knockouts: 8 total 1/2" - 3/4" combination	

AquaLink® RS will support control of up to 4 Infinite WaterColors Light Controllers per system. AquaLink EDGE will support up to 8 controllers per system. Each controller will support communication with up to 16 (15W) and 9 (25W) lights. Ensure the combined light wattage does NOT exceed 240W per controller.

⚠ WARNING

The Infinite WaterColors LED Light Controller should not be considered suitable for use as service equipment. Therefore, it is required to have the appropriate means of disconnection, circuit isolation, and/or branch circuit protection installed upstream of the power center.

Section 2. Best Installation Practices

Infinite WaterColors LED Lights use a digital communication protocol unlike Jandy WaterColors LED Lights. To ensure proper operation, it is essential to follow all installation best practices when wiring and connecting the Infinite WaterColors LED Light Controller.

Ensure that the pool meets the requirements of the current National Electrical Code® and all local codes and ordinances. A licensed or certified electrician must install the electrical system to meet or exceed those requirements before the underwater light is installed.

Optimal Wiring Architecture

- Keep low voltage wiring as short as possible. Do not exceed a combined 200' between the Infinite WaterColors LED Light Controller and Infinite WaterColors LED lights.
- Do not run low-voltage and high-voltage in the same conduit.
- Place the Infinite WaterColors LED Light Controller as close as possible to the junction box and lights.
- Multiple light controllers require dedicated conduit runs to each light/junction box; do not share conduit between different light controllers.
- For all installations, use a minimum of 10 AWG wire. Refer to Figure 5 for proper wire size on new or upgraded installations.

NOTE: If necessary, extend the AC line voltage distance between the Jandy automation system and the Infinite WaterColors LED Light Controller. Use proper shielded Type TC (or equivalent) cabling when AC power lines and RS-485 data cables share the same raceway.

- Junction box wire-to-wire connections should have maximum wire contact to reduce signal / voltage loss and ensure reliable performance.

Preferred connection methods:

1. Screw terminals / bus bar
2. Wire nuts
3. Lever / pushin nuts

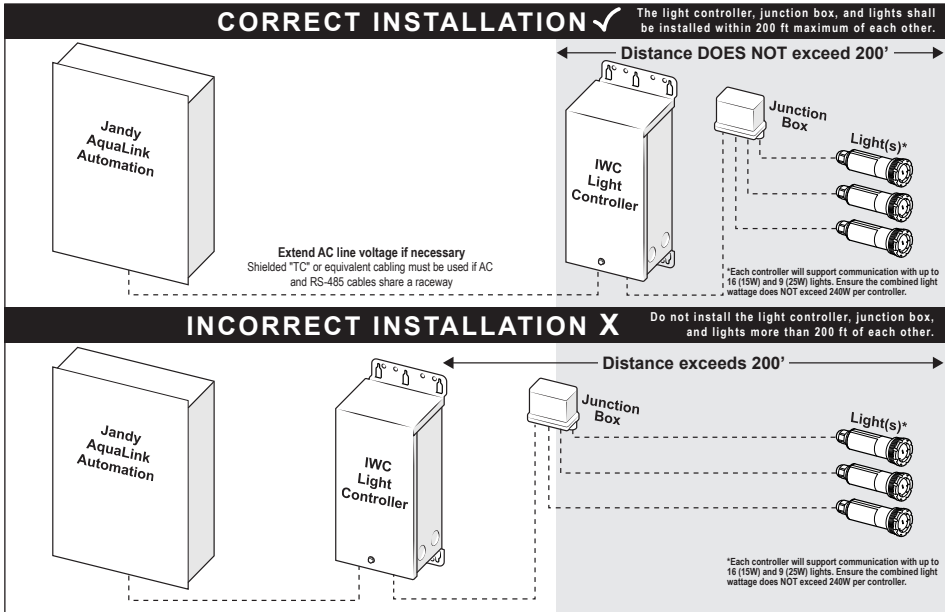

Figure 1. Infinite WaterColors Installation

- Aim for star network power distribution where possible. (See figure 2)
- Wire lights or junction boxes directly to the power source.

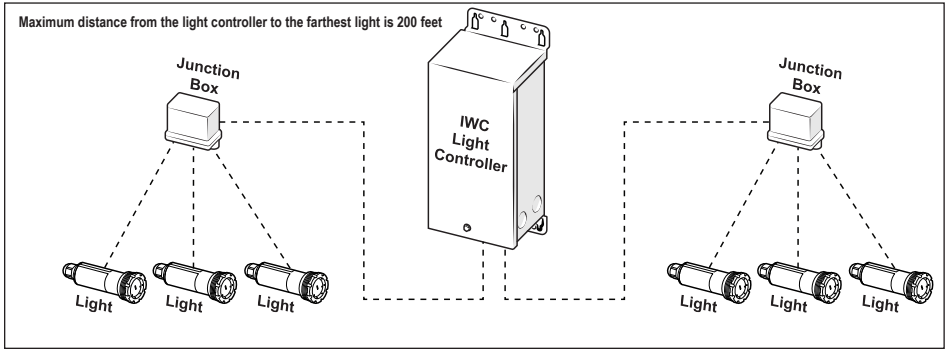

Figure 2. Star Distribution Network

- Junction boxes shall not be daisy chained together. This will create a large load of power at the end of the power distribution network and will result in communication losses. Wire directly to the power source instead. (See Figure 3)

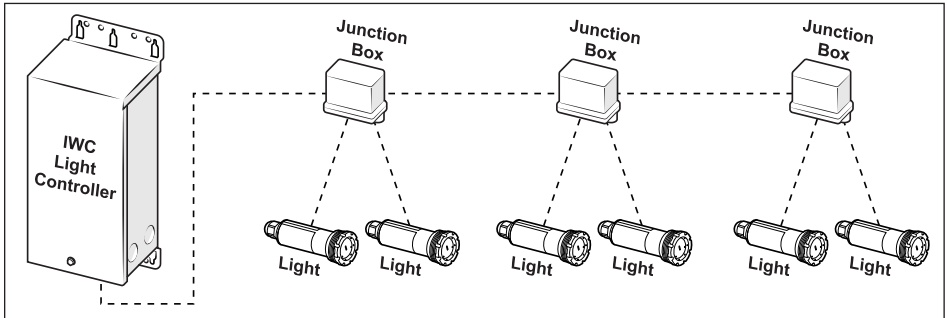

Figure 3. Do Not Daisy Chain Junction Boxes

Low Voltage Wire Gauge Selection

- Always use a minimum of 10-gauge (AWG) multi-stranded (braided) wire for the connection between the Infinite WaterColors LED Light Controller and the junction box.
- Do not wire to a relay. Must be wired directly to a circuit breaker.

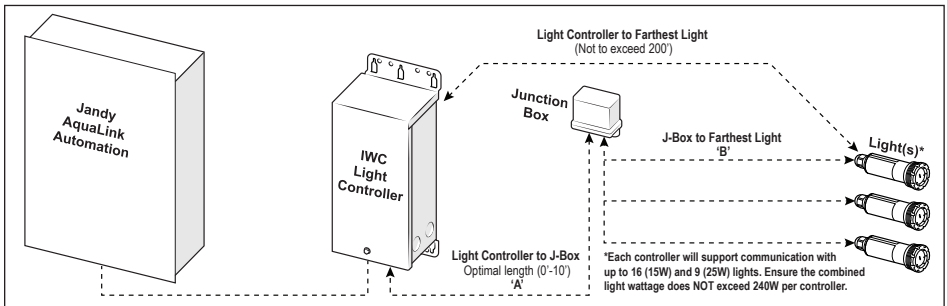

Figure 4. Jandy LED Infinite WaterColors Wiring Diagram



To determine the appropriate wire gauge needed, calculate the total wattage of all lights connected to each junction box.

- If your total light wattage is less than 120 watts, use 10 gauge (AWG) multi-stranded (braided) wire.
- If the total light wattage is over 120 watts, you must first determine Distance A, then Distance B, before consulting the charts below.

For total wattage between 120-180W see figure 5, for total wattage between 181-240W see figure 6.

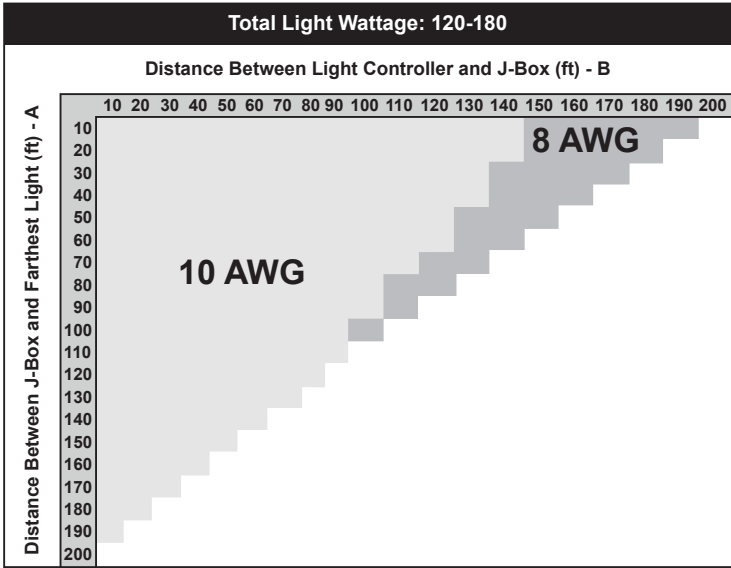

Figure 5. Wire Gauge Selection Chart 120-180W

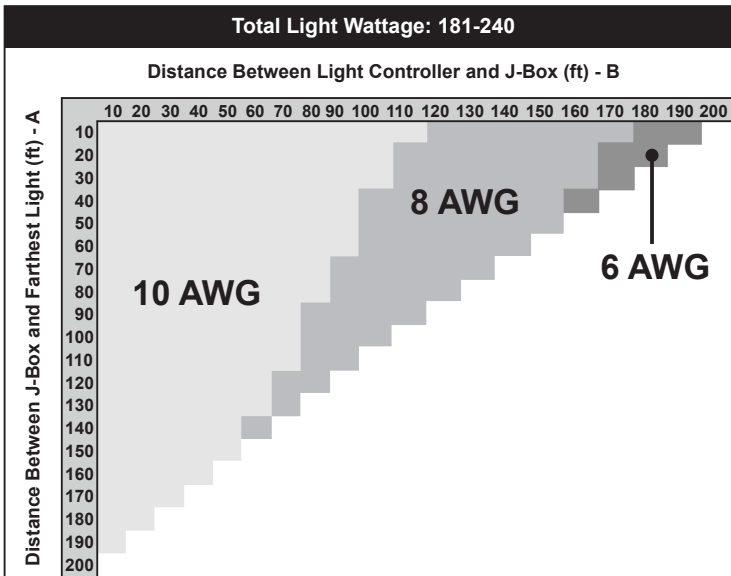

Figure 6. Wire Gauge Selection Chart 181-240W



Section 3. Installation

3.1 Location Requirements for Pool and Spa Light Applications

In order to protect the Infinite Water Colors LED Light Controller from pressurized water spray (such as that from irrigation sprinklers) and from mechanical impacts and/or damage, it should be located:

- At least 4 inches (10 cm) above the ground.
- At least 8 inches (20 cm) above the water level.
- At least 4 feet (1.3 m) from the inside edge of the pool or spa, at least 10 feet (3.05 m) from a fountain, or as required by local code.

3.2 Mounting

The Infinite WaterColors LED Light Controller is shipped with mounting brackets fastened on the back.

- Turn the Light Controller over and inspect the brackets installed inverted on the back.
 - If any parts are missing or damaged, please call your local distributor or technical support at 1.800.822.7933 for assistance.
1. Remove mounting screws from upper and lower brackets on the back of the Light Controller.
 2. Rotate and secure upper and lower brackets with mounting screws to the same mounting holes, see *Figure 7*.

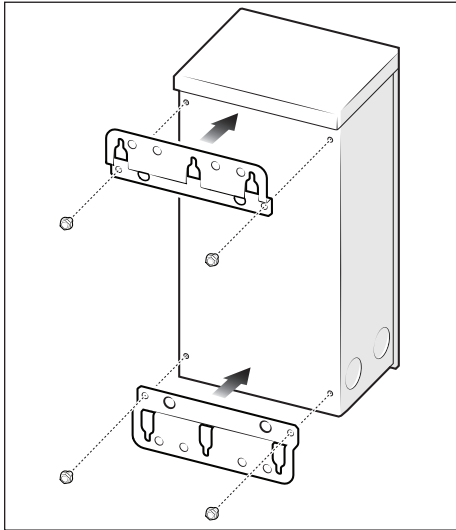

Figure 7. Install Brackets

3. Mark the location for the mounting screws.
4. Drill holes where the mounting screws will be installed.
5. Secure screws (or other hardware appropriate for the mounting surface) through either the keyhole slots or the mounting holes of the Light Controller enclosure, see *Figure 8*.

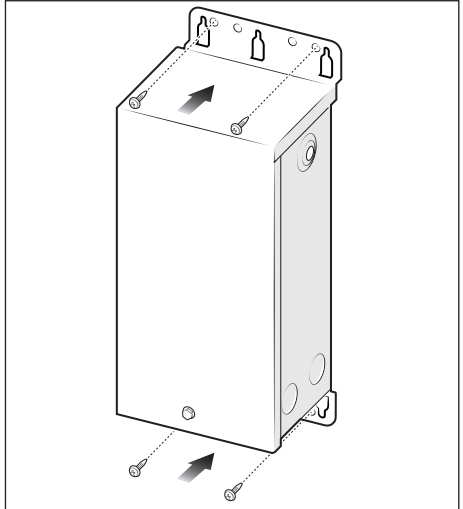

Figure 8. Mounting Light Controller

3.3 High Voltage Wiring

⚠ WARNING

RISK OF ELECTRIC SHOCK WHICH CAN RESULT IN SERIOUS INJURY OR DEATH: Before attempting to install or service, ensure that all power to the circuit supplying power to the system is disconnected or turned off at the circuit breaker. All wiring must be done in accordance with the National Electrical Code® (NEC)®, NFPA70®.

In Canada, the Canadian Electrical Code (CEC), CSA C22.1, must be followed. All applicable local installation codes and regulations must be followed.

Wiring connections must be made exactly as shown in the wiring diagram found on the inside of the Infinite WaterColors LED Light Controller cover. The NEC and CEC also require that pool equipment be bonded together as part of the equipotential bonding grid. Fluidra provides a labeled bonding lug on the bottom of the Light Controller to accommodate this requirement.

1. Turn off power at the breaker panel.
2. Remove the cover. The cover is held on by one screw, see *Figure 9 (a)*.
3. Remove a knockout from the bottom left side of the Light Controller.
4. Thread a conduit connector that is rated to local code into the knockout hole on the Light Controller, see *Figure 9 (b)*.
5. Feed 120 VAC through the conduit and conduit connector on the Light Controller, see *Figure 9*.

NOTE: Power the Infinite WaterColors LED Light Controller directly from a breaker, do NOT wire to a relay.

6. Connect the green ground wire to the ground terminal bar in the Light Controller, see *Figure 9 (c)*.
7. Use wire nuts to connect the line wires (black to black) and neutral wires (white to white), see *Figure 9 (d)*.
8. Proceed to *Section 2.4, Low Voltage Wiring and Communication*.

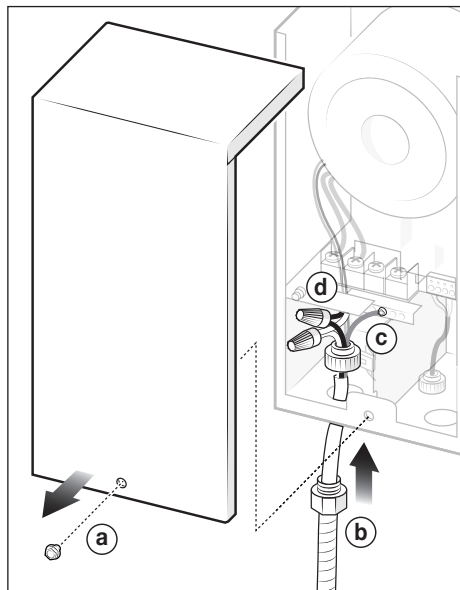

Figure 9. Connect High Voltage Wires

3.4 Low Voltage Wiring and Communication

1. Remove a knockout from the bottom right side of the Light Controller.
2. Thread a conduit connector into the knockout hole on the Light Controller, see *Figure 10*.

NOTE: Provide a dedicated conduit for each light controller. For systems with more than one controller, ensure that the wiring for each controller is routed through its own separate conduit.

3. Feed low voltage light cord through the conduit and conduit connector on the Light Controller, see *Figure 10*.

NOTE: It is recommended to add a junction box when installing more than two lights. Low voltage wires are not polarity sensitive.

4. Use wire nuts to connect the low voltage light wires, white wire connects to orange wire and black wire connects to orange wire, see *Figure 9*. If installing a niched light, connect the green ground wire to the terminal bar in the controller.
5. Install cover and secure hand tight with the screw provided.
6. Turn on the breaker to restore power.

NOTE: For AquaLink RS systems with multiple Jandy Infinite WaterColors LED Light Controllers, ensure only one controller is powered at a time when assigning lights to minimize risk of crosstalk between units.

7. Once power is restored, verify pool lights perform the "rainbow sequence" (it could take up to two minutes), this indicates the lights are powered and communicating to the Light Controller.

NOTE: A blinking yellow pool light means no communication between lights and the light controller.

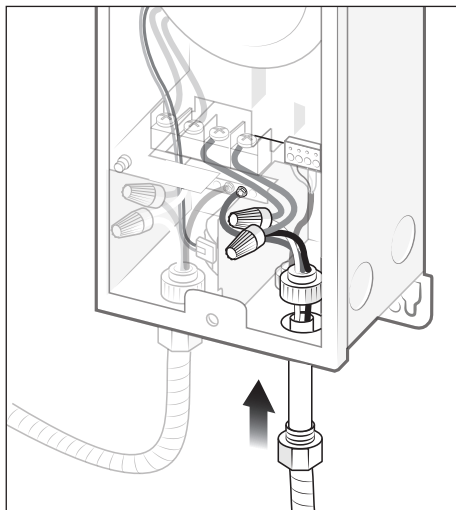

Figure 10. Connect Low Voltage Wires

3.5 RS-485 Wiring and Communication

1. Turn off power at the breaker panel.
2. Screw the antenna onto the connector hand tight.

NOTE: When connecting the device the antenna may be repositioned or relocated (using R1106900 - AquaLink EDGE Antenna Mount with Extension) for improved connection as needed.

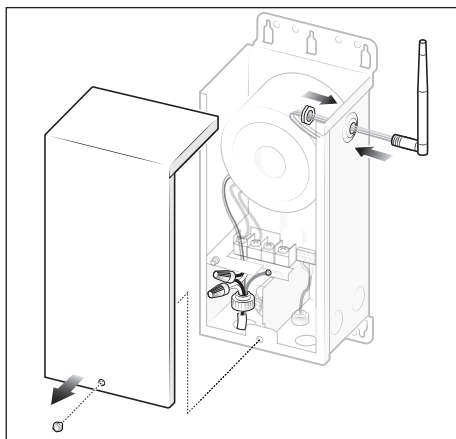

Figure 11. Antenna Install

See instructions to connect via Wi-Fi in your AquaLink EDGE manual.

The antenna LED light ring shows the status of the light controller when connected to an AquaLink RS or AquaLink EDGE automation system. See Figure 12 for descriptions of the status indicators.

LED Light Ring Indicators When connected to RS, light ring will remain off	
SOLID	
Green	Connected, verified
Blue	BLE pairing
Yellow	Service mode
Red	Cannot connect, already verified
SLOW FLASH	
Green	Connected, not verified
Red	Not connected, not verified
Yellow	OTA in progress
FAST FLASH	
Blue	Find me enabled

Figure 12. LED Light Ring Indicators

- Remove the cover. The cover is held on by one screw, see Figure 9 (a)
- RS-485 comes factory wired to the Light Controller. Connect the low voltage RS-485 communication low voltage wires to either the AquaLink RS or AquaLink EDGE automation system. First wire red (R) to 1, black (B) to 2, yellow (Y) to 3, and green (G) to 4 on the connector, see Figure 13.

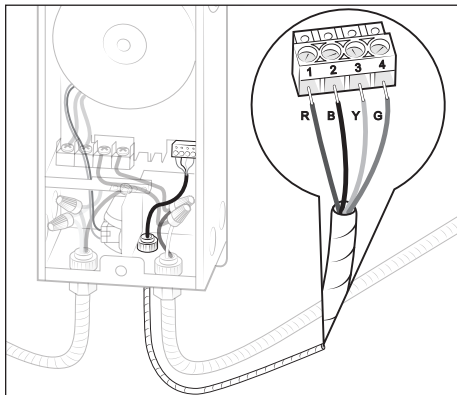

Figure 13. Connect RS-485 Wires

- Check all connection points and wiring for secure connections.

NOTE: Cover screw ensures bonding to ground, and must be secured in place.

- Turn on the breaker to restore power. Confirm the LED status indicators listed below:

- LED1: Turns on red when powered
 - LED2: Continuously flashes green when communicating to automation
 - LED3: Turns on yellow if communicating with AquaLink EDGE
 - LED4: Flashes blue if a communication error with lights is detected
- Pool & Spa Lights will be off due to control from automation, see Figure 14.

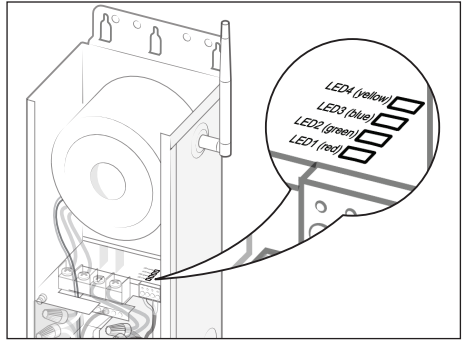

Figure 14. LED Lights

- Install cover and secure hand tight with the screw provided.

3.6 Bonding

Fluidra requires that the Infinite Water Colors LED Light Controller be connected to a “bonding loop” that includes all electrical equipment in the system and on the equipment pad. Bonding lugs must be connected with a solid copper wire not smaller than 8 AWG (6 AWG in Canada). Failure to do so may void the Fluidra warranty.

⚠ CAUTION

To prevent premature failure of the equipment resulting from stray voltages and voltage differentials, the Infinite WaterColors LED Light Controller must be bonded to other equipment which is part of the pool plumbing system with a solid copper wire not smaller in diameter than 8 AWG (6 AWG in Canada).

Additionally, in the United States the National Electrical Code® (NEC®) and in Canada the Canadian Electrical Code (CEC), require that all metallic components of a pool structure, including reinforcing steel, metal fittings and above ground components be bonded together (forming an equipotential bonding grid) with a solid copper conductor not smaller than an 8 AWG (6 AWG in Canada).

The NEC and CEC also require that the equipment and/or appliances associated with the pool water circulating system, including, but not limited to, pump motors and heaters, be bonded together as part of the equipotential bonding grid. Fluidra provides special labeled bonding lugs on the bottom of the power center to accommodate this requirement.



After bonding the electronics to the grounding lug, installer must verify ground continuity of all metal components using a multimeter.

⚠ WARNING

Installer must ensure that the Infinite WaterColors LED Light Controller is in acceptable working condition; including all seals/gaskets must be in place and functional; grounding lug must be present, functional, and bonded; and corrosion must not compromise ingress protection against weather. Additionally, all hardware must be present and functional. If any of the aforementioned conditions are not met, a new enclosure **MUST** be used.

⚠ WARNING

Risk of electric shock which can result in serious injury or loss of life. Before attempting to install or service, ensure that all power to the circuit supplying power to the system is disconnected or turned off at the circuit breaker. All wiring must be done in accordance with the National Electrical Code® (NEC)®, NFPA-70®.

In Canada, the Canadian Electrical Code (CEC), CSA C22.1, must be followed. All applicable local installation codes and regulations must be followed.

Wiring connections must be made exactly as shown in the wiring diagram found on the inside of the Infinite WaterColors LED Light Controller cover. The NEC and CEC also require that pool equipment be bonded together as part of the equipotential bonding grid. Fluidra provides a labeled bonding lug on the bottom of the Light Controller to accommodate this requirement.

Section 4. Connecting to Automation

This product requires connection to either Jandy AquaLink RS (Rev Y or greater), or AquaLink EDGE. The programming is different based on which automation system is being used. Download the iAquaLink app or upgrade to the latest version prior to light and zone set up. App function and design is subject to change.

NOTE: When replacing lights, make sure to follow these steps:

- Remove any existing light aux names (system setup > label aux >)
- Remove previous light aux labels (system setup > color lights)
- Remove schedules of light auxiliaries (system setup > schedules)

4.1 Connected to AquaLink RS

4.1.1 Light Setup

NOTE: For AquaLink RS systems with multiple Jandy Infinite WaterColors LED Light Controllers, ensure only one controller is powered at a time when assigning lights to minimize risk of crosstalk between units.

1. Open the app on your device.

2. From My Systems page, select your pool.
3. From the home page, choose the cog system icon on the top right and select System Setup.

• Assign Lights

1. From the System Setup page, select Light Setup and Assign Lights.
2. From the Assign Lights pop up, choose proceed to continue the process.
3. On the Light Zone Setup page, select a light in order to move it to a different zone. Selected light will flash the color of the zone it's currently assigned to. Follow further instructions in the app.

NOTE: Default zone colors include: zone 1 (green), zone 2 (white), zone 3 (red), and zone 4 (blue).

When exiting the Light Zone Setup page, the lights will turn off.

Lights have to be assigned to a zone in order to rename the zone.

• Name Light Zones

1. Go to > System Setup > Light Setup > Zone Name.
2. From the Edit Zone Name pop up, enter the zone name and choose OK.

4.1.2 Turn Lights On/Off

1. Open the app on your device.
2. From My Systems page, select your pool.
3. Choose the equipment page.
4. Turn zone lights on/off by tapping the toggle to the right of the desired zone.

NOTE: Ability to turn light zones on/off is only done through the app.

4.1.3 Select Colors

1. Open the app on your device.
2. From the My System page, select your pool.

• Select Custom Color

1. Go to > equipment page.
2. From the equipment page, choose the zone you want to change color.
3. From that zones page, choose Custom Color.
4. Choose your custom color from the color wheel.
5. Choose Apply to apply the custom color to your zone.

• Preset Colors

1. Go to the equipment page and select the zone you want to change color.
2. After selecting the zone, then choose from the list of preset colors to apply that preset color to your zone.

• Preset Color Shows

1. From equipment page, choose the zone you want to change color.
2. After selecting the zone, then choose from the list of preset color shows to apply that preset color show to your zone.

4.1.4 Adjust Brightness

1. From the equipment page, select the sun icon on the zone where you want to adjust the brightness.
2. Move the slider bar up or down with your finger and then click apply to change the brightness.

4.2 Connected to AquaLink EDGE

4.2.1 Light Setup

Navigate to the light assignment center on the EDGE display. Follow the on-screen instruction to set up your lights. Light controls are grouped inside spaces.

4.2.2 Turn Lights On/Off

To turn lights on enter the space and select the light group. Follow the on-screen instructions to achieve the desired effect.

4.2.3 Select Colors

To select colors enter the space and select the light group. Follow the on-screen instructions to achieve the desired effect.

Section 5. Additional Online Content

For information on the following, please refer to the online manual:

- System Overview
- OneTouch Setup (AquaLink RS only)
- Amazon Alexa Light Control (AquaLink RS only)
- Online content for EDGE
- Troubleshooting

Section 6. Troubleshooting

PROBLEM	POSSIBLE CAUSE	CORRECTION ACTION
Lights don't turn on	Light zone is not enabled	Ensure that the light is in an enabled zone.
	No power / controller failure (red LED off)	Verify the following: <ul style="list-style-type: none"> - The breaker has not tripped. - 120 VAC is present on the input pigtail, check wiring if not present. - 14VAC is present on screw terminals. - The light controller's red LED is on. If NO, verify the automation fuse has not blown. - If the automative fuse has not blown, replace controller PCBA.
	Light wiring	Verify the junction box closest to the light is reading 14 VAC. Rewire the connections to ensure good electrical contact. Ensure that appropriately sized stranded wire is being used. Refer to Low Voltage Wire Gauge Selection on page 6-7.
	Light failure	Disconnect RS485 from the light controller and power cycle the unit. Check whether the light performs the "rainbow" sequence. For niched lights, remove the light from the pool and open to check for 14VAC on the terminals inside. If OV, replace the full unit (broken cable), otherwise replace the PCBAs only.
Lights are out of sync	Zones are set differently	Verify that lights are in the same zone, or the same light show is applied to all zones
One or more lights are dim, blinking or not working	Poor connection	Verify wiring and connections
	Voltage sag	Verify that the correct wire gauge is being used and is stranded. Refer to Low Voltage Wire Gauge Selection on page 6-7.
	Cross talk between multiple light controllers	To ensure that there are no learn in issues or duplicate lights as a result of cross talk between multiple light controllers at startup, or when replacing one or more lights, follow the steps below to reset the units and learn the lights in correctly: <ul style="list-style-type: none"> - Ensure light controllers are routed in separate, dedicated conduits or run with shielded cable. Shared conduit with multiple light controllers will result in crosstalk issues. - Disconnect RS485 from all light controllers. - Factory reset all light controllers by holding the factory reset button on the control board for 7 seconds while powered. - Power off all light controllers. - Clear memory on the RS, or forget the device in EDGE. - Plug in RS485 to all light controllers. - Power on 1 light controller at a time to learn the controller and lights into automation. - Once all light controllers have been learned in, set up zones and assign lights. - Verify the issues are resolved.
Lights are flashing yellow	Third party transformer	Only the Jandy LED Light Controller can be used to power and communicate with Infinite WaterColors lights. Replace any third party transformers with IWCLC300W2.
	Controller communication	Check the DCT red LED status. If the unit is OFF, verify that 14 VAC is present at the screw terminals. If 14 VAC is confirmed, replace the DCT. If ON, verify that the wiring is properly sized, stranded, and that secure connections are present at each junction box. Refer to Best Installation Practices on pages 5-7

Different colors from other lights	Lights in different zones	Verify that lights are in the same zone, or that all zones are set to the same color. If colors still wont match, refer to light failure corrective actions.
	Light failure	Turn all lights to Ruby Red, then Emerald Green, then Cobalt Blue. If any of the colors did NOT work, check the light for physical damage or water intrusion.
Zones / lights not showing up in the app	No lights connected	Verify at least 1 light is conencted. Light setup and zones will only appear once at least 1 light is connected and communicating.
	RS485 wiring / communication	Check if light controller green LED is flashing. If yes, confirm the controller appears in the automation device list and continue with the following steps. - Verify that wiring is correct (1 - red, 2 - black, 3 - yellow, 4 - green). Incorrect wiring at other devices can also affect the light controller. - Check for 10 VDC at the light controller red 4-pin connector. If no voltage is present, proceed to the next step. - Check continuity on black and yellow comm wires between automation and the light controller to ensure they are not damaged or broken.
	Automation failure	Confirm if other RS485 devices operating properly. If not, verify for the following: - Check for 10 VDC at the RS system. If 10 VDC is missing, replace the RS. - Check for continuity between automation and light controller red 4 pins to ensure no RS485 wires are broken.
	Light controller failure	Unplug the RS485 and power cycle the light controller. Verify the lights perform the "rainbow" sequence on power up. -If yes, the device is good, check comms further. -If no, connect a known good light directly to the light controller to identify whether the issue is the controller or light. Replace as needed.