

JENN-AIR BOTTOM FREEZER REFRIGERATOR



USER GUIDE

TABLE OF CONTENTS

Introduction.....	2	Freezer Features	13
Important Safety Information.....	3	Automatic Ice Maker	13
Installation Instructions.....	4-9	Drawers.....	13
How to Remove the Doors and Hinges	4	Accessories	13
How to Reverse Refrigerator Door.....	5	Water Filtration	14
How to Install and Remove Handles.....	5	Water Filter Data	15
How to Replace the Doors and Hinges.....	6	Hints and Care	16
How to Install and Remove Panels.....	6	Cleaning Instructions.....	16
How to Remove and Install the Pullout Drawer.....	7	How to Remove and Replace Light Bulbs	17
How to Connect the Water Supply.....	8	Food Storage Tips	18
How to Level Your Refrigerator	9	Food Storage Chart	19
Temperature Controls.....	10	Normal Operating Sounds	20
Fresh Food Features.....	11-12	Before You Call For Service	21-22
Water Dispenser	11	Warranty.....	23
Interior Shelves.....	11	Guide de L'Utilisateur	25
Door Storage.....	11	Guía del Usuario.....	49
Climate-Controlled Drawers	12		
Accessories	12		

INTRODUCTION

Congratulations on the purchase of a Jenn-Air refrigerator!

We appreciate your purchase decision and feel confident you will be happy with this appliance for years to come. For best results, please read this guide carefully. You will find instructions on the proper operation and maintenance of your refrigerator. Additionally, food storage information has been included for you.

Should you ever need our future assistance with your refrigerator, a complete model and serial number recorded in the spaces below will be extremely helpful. These numbers are found on a data plate inside the refrigerator compartment on the upper surface.

Model Number _____

'P' Number _____

Serial Number _____

Purchase Date _____

Dealer Name _____

Dealer Address _____

Dealer Phone _____

BEFORE CALLING FOR SERVICE...

If something seems unusual, please check the "Before You Call For Service" section, which is designed to help you solve basic problems before calling a servicer.

WHAT IF THESE FEATURES ARE DIFFERENT FROM MINE?

This book is intended to show the variety of features that are available in the product line. If your refrigerator does not have all the options that are shown, many of these options may be purchased by contacting the Consumer Affairs Department. If you have questions, write us (include your model number and phone number) or call:

Maytag Appliances Sales Company
Attn: CAIR® Center
P.O. Box 2370
Cleveland, TN 37320-2370
U.S. and Canada 1-800-JENNAIR
(1-800-536-6247)
1-800-688-2080 (U.S.A. TTY for
hearing or speech impaired)
(Mon.-Fri., 8 am-8 pm Eastern Time)
Internet: <http://www.maytag.com>



IMPORTANT SAFETY INFORMATION

WHAT YOU NEED TO KNOW ABOUT SAFETY INSTRUCTIONS

Warning and Important Safety Instructions appearing in this manual are not meant to cover all possible conditions and situations that may occur. Common sense, caution, and care must be exercised when installing, maintaining, or operating refrigerator.

Always contact your dealer, distributor, service agent, or manufacturer about problems or conditions you do not understand.

RECOGNIZE SAFETY SYMBOLS, WORDS, LABELS

⚠ DANGER:

DANGER – Immediate hazards which **WILL** result in severe personal injury or death.

⚠ WARNING:

WARNING – Hazards or unsafe practices which **COULD** result in severe personal injury or death.

⚠ CAUTION:

CAUTION – Hazards or unsafe practices which **COULD** result in minor personal injury.

⚠ DANGER:

To reduce risk of injury or death, follow basic precautions, including the following:

IMPORTANT: Child entrapment and suffocation are not problems of the past. Junked or abandoned refrigerators are still dangerous – even if they sit out for “just a few days.” If you are getting rid of your old refrigerator, please follow the instructions below to help prevent accidents.

Before you throw away your old refrigerator or freezer:

- > Take off the doors.
- > Leave the shelves in place so children may not easily climb inside.

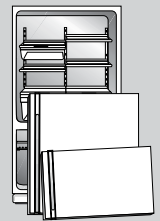

⚠ WARNING:

To reduce risk of fire, electric shock, serious injury or death when using your refrigerator, follow these basic precautions, including the following:

1. Read all instructions before using the refrigerator.
2. Observe all local codes and ordinances.
3. Be sure to follow grounding instructions.
4. Check with a qualified electrician if you are not sure this appliance is properly grounded.
5. **DO NOT** ground to a gas line.
6. **DO NOT** ground to a cold-water pipe.
7. Refrigerator is designed to operate on a separate 103 to 126 volt, 15 amp., 60 cycle line. **DO NOT** modify plug on power cord. If plug does not fit electrical outlet, have proper outlet installed by a qualified electrician.
8. **DO NOT** use a two-prong adapter, extension cord or power strip.
9. **DO NOT** remove warning tag from power cord.
10. **DO NOT** tamper with refrigerator controls.
11. **DO NOT** service or replace any part of refrigerator unless specifically recommended in Owner's Manual or published user-repair instructions. **DO NOT** attempt service if instructions are not understood or if they are beyond personal skill level.
12. Always disconnect refrigerator from electrical supply before attempting any service. Disconnect power cord by grasping the plug, not the cord.
13. Install refrigerator according to Installation Instructions. All connections for water, electrical power and grounding must comply with local codes and be made by licensed personnel when required.
14. Keep your refrigerator in good condition. Bumping or dropping refrigerator can damage unit or cause unit to malfunction or leak. If damage occurs, have refrigerator checked by qualified service technician.
15. Replace worn power cords and/or loose plugs.
16. Always read and follow manufacturer's storage and ideal environment instructions for items being stored in refrigerator.

SAVE THESE INSTRUCTIONS

INSTALLATION INSTRUCTIONS

These instructions were provided to aid you in the installation of your refrigerator.

MEASURING THE OPENING

A ½" of air space should be provided for the back of the unit to allow for the power cord and water line. When installing your unit, measure carefully.

Subflooring or floor coverings (i.e. carpet, tile, wood floors, rugs) may make your opening smaller than anticipated.

Some clearance may be gained by using the leveling procedure on page 9.

IMPORTANT: If unit is to be installed into a recess where top of unit is completely covered, use dimensions from floor to top of hinge cap to verify proper clearance.

TRANSPORTING YOU REFRIGERATOR

Follow these tips when moving the unit to final location:

- **NEVER** transport unit on its side. If an upright position is not possible, lay unit on its back. Allow unit to sit upright for approximately 30 minutes prior to plugging unit in to assure oil return to the compressor. Plugging unit in immediately may cause damage to internal parts.
- Use an appliance dolly when moving unit. **ALWAYS** truck unit from its side—**NEVER** from its front or back.
- Protect outside finish of unit during transport by wrapping cabinet in blankets or inserting padding between the unit and dolly.
- Secure unit to dolly firmly with straps or bungee cords. Thread straps through handles when possible. **DO NOT** overtighten. Overtightening restraints may dent or damage outside finish.

SELECTING THE BEST LOCATION

- Allow for a free flow of air through the front base grille.
- Install the refrigerator where the room temperature will not go below 55° F. With temperatures below 55° F, the refrigerator will not run frequently enough to maintain proper temperature in the freezer.
- Locate the refrigerator away from heat producing appliances such as the range or dishwasher, heat vents and direct sunlight.
- A minimum of ½" clearance is required at the back. Allow ½" at the sides for ease of installation. If refrigerator is placed with the door hinge side against a wall, you may want to allow additional space.
- Use caution when installing the refrigerator on vinyl or hardwood floors so as not to mark or otherwise damage the flooring. A piece of plywood, a rug or other material should be used to protect the floor while positioning the refrigerator.

HOW TO REMOVE THE DOOR AND HINGES

Some installations require door removal to transport refrigerator to its final location.

To remove drawer, see instructions on page 7.

⚠ WARNING:

To avoid electrical shock which can cause severe personal injury or death, observe the following:

- Disconnect power to refrigerator before removing doors. Connect power only after replacing doors.

⚠ CAUTION:

To avoid damage to walls and flooring, protect soft vinyl or other flooring with cardboard, rugs or other protective material.

1. Unplug power cord from power source.
2. Remove toe grille and bottom bracket covers.
3. Remove the top trim of fresh food door with Phillips screwdriver.

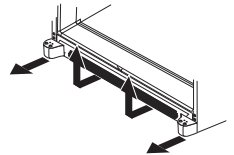

- Retain screws and trim for replacement.
4. Unscrew 5/16" hex head screws from top hinge to remove hinge.

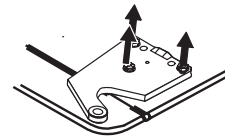

- Retain all screws for later use.
5. Lift refrigerator door from center hinge pin.
 6. Remove center hinge pin with a 5/16" hex nut driver.

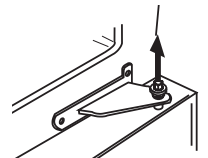

- Retain hinge pin for later use.
7. Remove Phillips screws to remove center hinge.

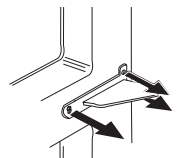

- Retain all screws for later use.
8. Remove both stabilizing brackets with 3/8" hex head driver.
- Retain screws for later use.

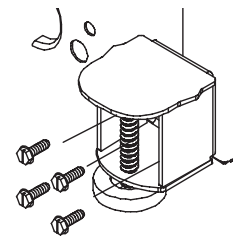

HOW TO REVERSE REFRIGERATOR DOOR

Note:

When working directly on door, lay the interior side of the door down flat, nonabrasive surface. If using a floor or table, prepare working surface with rugs or towels to avoid damage to door finish.

DOORS WITH TRIM AND PANELS

1. Perform all steps listed in **How to Remove the Door and Hinges**.
2. Perform removal steps listed in **How to Remove and Install Handles**.
3. Transfer cabinet plugs and screws to opposite side of cabinet.
4. Remove plugs with flat blade of screwdriver wrapped in masking tape.
5. Remove center mullion screws with $\frac{5}{16}$ " hex head driver.
6. Locate door stop (B) and door cap (A) on bottom edge of fresh food door. Remove with a Phillips screwdriver.

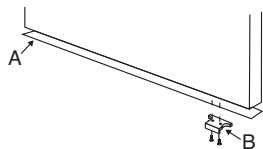
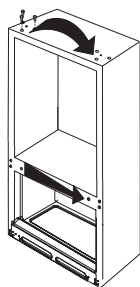

- Retain all items for later replacement.

⚠ WARNING:

To avoid possible injury and damage to property, tape decorative panels (some models) securely into place before removing side door trim and handles.

7. Remove side door trim (A) and handle side trim (B) from door by tapping bottom edges upward with a soft rubber mallet.

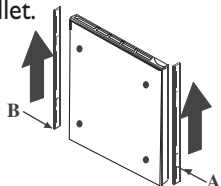

- Trim will slide up approximately $\frac{3}{4}$ " and release from door.

8. Rotate door panel 180° and tape in place.
9. Remove top door extension with $\frac{1}{4}$ " hex head driver. Flip door extension (A) so notched corner turns in toward interior of door (B).

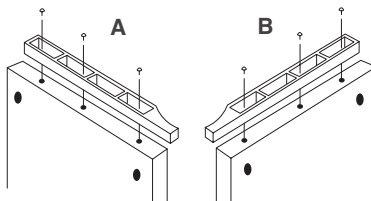
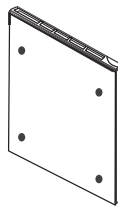

10. Retrieve alternate side door trim shipped with refrigerator. Install trim by aligning notches of trim with metal mounting tabs on side of door.

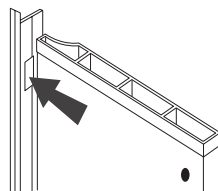

- Slide trim down until piece locks into place.
- Tap top of trim with rubber mallet to insure snug fit.
- Repeat same procedure to install handle side trim removed in step 7.

11. Replace bottom door cap (A) removed in step 6. Install door stop (B) on opposite side of door.



12. Remove tape from panels.
13. Proceed to next column to reinstall handle.

HOW TO INSTALL AND REMOVE HANDLES

In some cases, handles may need to be removed to transport unit through tight spaces, reverse doors, or install panels.

Some models may come with handles shipped separate from the refrigerator door.

INSTALLING HANDLES

1. Retrieve handle from shipping material (some models).
2. Locate handle mounting posts on face of door.
3. Position handle over mounting posts.
4. Tighten set screws (A) with a $\frac{3}{32}$ " Allen wrench.

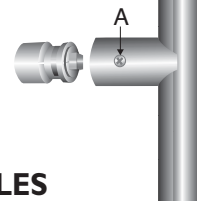

REMOVING HANDLES

1. Locate set screws in handle and loosen set screws with a $\frac{3}{32}$ " Allen wrench.
2. Lift handle from handle mounting posts to remove.

Note:

In cases of door reversal, panel installation, or panel removal, the mounting posts must be removed. Use a $\frac{1}{4}$ " hex head driver to remove the post from the door.

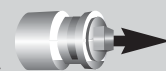

INSTALLATION INSTRUCTIONS, CONT.

HOW TO REPLACE THE DOOR AND HINGES

1. Install center hinge with Phillips screws.
2. Install stabilizing brackets with $\frac{3}{8}$ " hex head screws.
3. Replace center hinge pin.
4. Place hinge side of refrigerator door on center hinge pin.

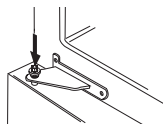

Note:

If fresh food door is being reversed, install alternate top hinge from literature assembly.

5. While holding refrigerator door upright, tighten down top hinge with $\frac{5}{16}$ " hex head driver.
6. Install top door trim of fresh food door with a Phillips screwdriver.

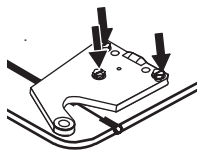

HOW TO INSTALL AND REMOVE PANELS (SOME MODELS)

⚠ WARNING:

To avoid personal injury or property damage, fresh food panel should not weigh more than 30 lbs (14 kgs) and freezer panel should not weigh more than 15 lbs (7 kgs).

TO INSTALL PANELS:

1. Perform the handle removal instructions in **How to Install and Remove the Handles**, including instructions to remove mounting posts from door face.
2. Remove top door trim.
3. Remove handle side door trim.
4. Slide panel in the handle side of door, by using grooves provided by bottom door cap and side door trim.
5. Replace mounting posts, handles, and trim.

TO REMOVE PANELS:

1. Perform the handle removal instructions in **How to Install and Remove the Handles**, including instructions to remove mounting posts from door face.
2. Remove top door trim.
3. Remove handle side door trim.
4. Slide panel out the handle side of door.

WHAT IF I AM INSTALLING RAISED PANELS?

Please see recommended dimensions for paneling. All panel holes are $\frac{1}{4}$ " diameter.

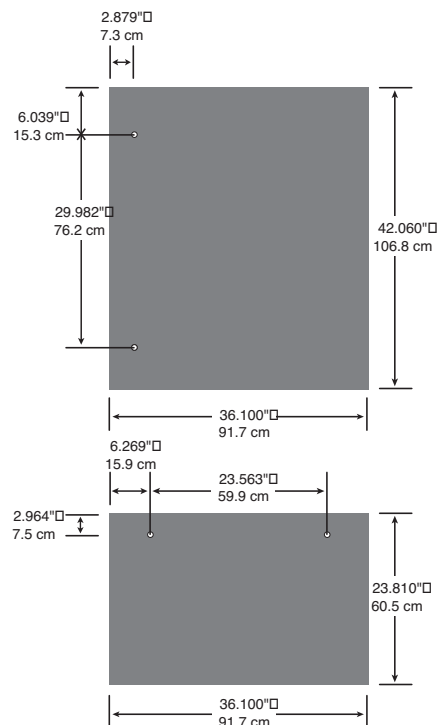

HOW DO I MOUNT HANDLES ON RAISED PANELS?

The refrigerator is shipped with the handle mounting posts attached to the door with $\frac{1}{4}$ " hex head screw that is approximately $1\frac{1}{2}$ " long. This length is necessary to safely secure the mounting post to the door.

If handles are being mounted to a raised surface, the factory supplied hex head screws will have to be replaced with a longer version. To determine how long the replacement screw must be, add the thickness of the raised panel to the $1\frac{1}{2}$ " measurement. See example below.

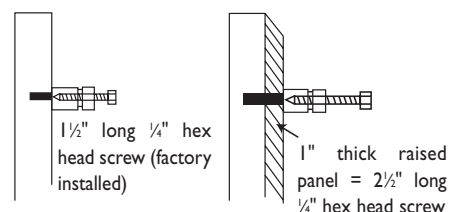

HOW TO REMOVE AND INSTALL THE PULLOUT DRAWER

⚠ WARNING:

To avoid electrical shock which can cause severe personal injury or death, disconnect power to refrigerator before removing doors. After replacing doors, connect power.

⚠ CAUTION:

To avoid possible injury, product, or property damage, you will need two people to perform the following instructions.

To remove:

1. Pull upper basket out to full extension and lift out to remove.

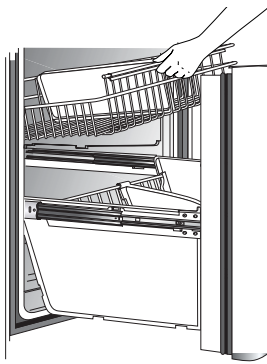

2. Remove lower basket by lifting basket from rail system. (Model design may vary.)

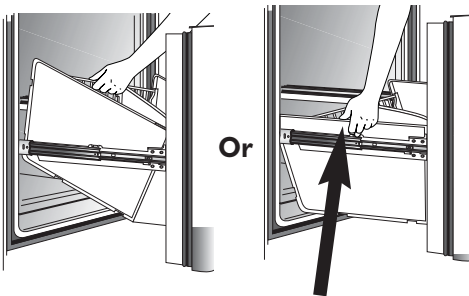

Press Tab Here
(some models)

3. Pull drawer open to full extension.
4. Remove Phillips screw from each side of rail system. (Some models)

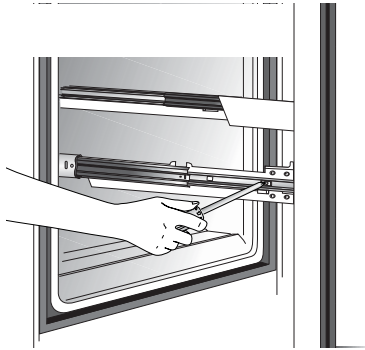

5. Lift top of door to unhook door supports from rail system. Lift door out to remove.

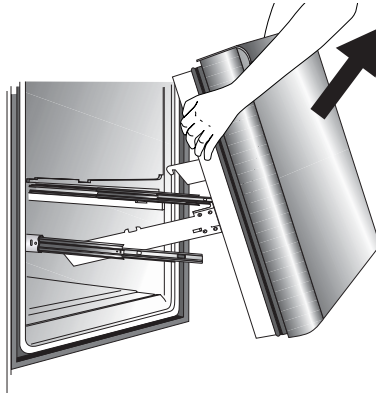

To install:

1. Pull both rails out to full extension.

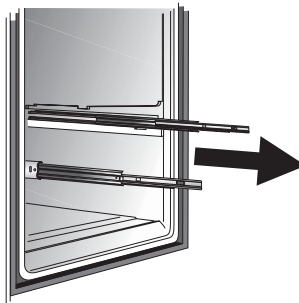

2. While supporting door, hook door supports into tabs located on inside of rail.

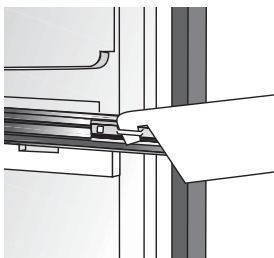

3. Lower door into final position.
4. Replace and tighten Phillips screws that were removed from each side of rail system.

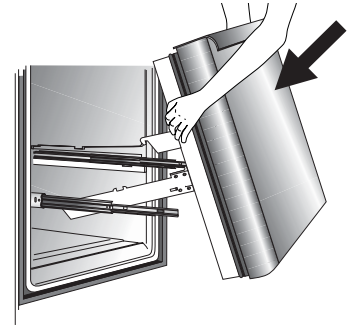

5. With drawer pulled out to full extension, insert lower basket by aligning tabs on both sides of lower basket with notches in rail assembly. Verify that the basket sides are hooked securely over the rails.

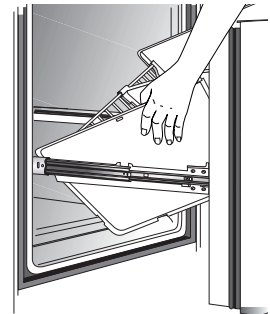

6. Slide upper basket into freezer. Make sure that rear of basket hooks behind rail catch.

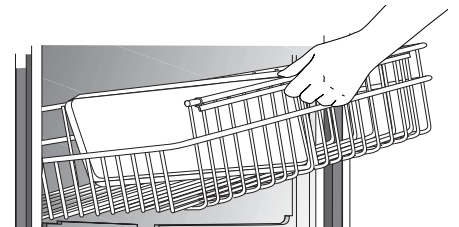

INSTALLATION INSTRUCTIONS, CONT.

HOW TO CONNECT THE WATER SUPPLY

⚠ WARNING:

To reduce the risk of injury or death, follow basic precautions, including the following:

- Read all instructions before installing device.
- DO NOT attempt installation if instructions are not understood or if they are beyond personal skill level.
- Observe all local codes and ordinances.
- DO NOT service device unless specifically recommended in owner's manual or published user-repair instructions.
- Disconnect power to unit prior to installing device.

⚠ CAUTION:

To avoid property damage or possible injury, follow basic precautions, including the following:

- Consult a plumber to connect copper tubing to household plumbing to assure compliance with local codes and ordinances.
- Confirm water pressure to water valve is between 20 and 100 pounds per square inch. If water filter is installed, water pressure to water valve must be a minimum of 35 pounds per square inch.
- DO NOT use a self-piercing, or $\frac{3}{16}$ " saddle valve! Both reduce water flow, become clogged with time, and may cause leaks if repair is attempted.
- Tighten nuts by hand to prevent cross threading. Finish tightening nuts with pliers and wrenches. Do not overtighten.
- Wait 24 hours before placing unit into final position to check and correct any water leaks.

MATERIALS NEEDED

- $\frac{1}{4}$ " outer diameter flexible copper tubing
- Shut-off valve (requires a $\frac{1}{4}$ " hole to be drilled into water supply before valve attachment)
- Adjustable wrench
- $\frac{1}{4}$ " hex nut driver

Note:

Add 8' to tubing length needed to reach water supply for creation of service loop.

1. Create service loop with tubing using care to avoid kinks in tubing.

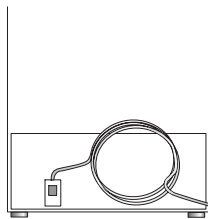

2. Remove plastic cap from water valve inlet port.

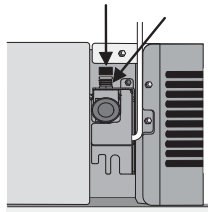

3. Place brass nut (A) and sleeve (B) on copper tube end as illustrated.

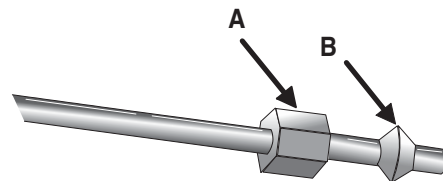

4. Place end of copper tubing into water valve inlet port. Shape tubing slightly – DO NOT KINK – so that tubing feeds straight into inlet port.

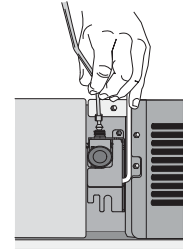

5. Slide brass nut over sleeve and screw nut into inlet port. Tighten nut with wrench.

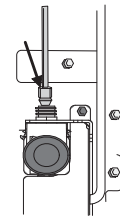

IMPORTANT: DO NOT overtighten. Cross threading may occur.

6. Pull on tubing to confirm connection is secure. Connect tubing to frame with water tubing clamp (C) and turn on water supply. Check for leaks and correct, if present.

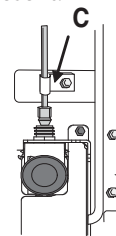

7. Monitor water connection for 24 hours. Correct leaks, if necessary.

HOW TO LEVEL YOUR REFRIGERATOR

If your refrigerator requires an ice maker water supply connection, complete connection instructions on page 8 before leveling your refrigerator.

⚠ CAUTION:

To protect personal property or unit from damage, observe the following:

- Protect soft vinyl or other flooring with cardboard, rugs, or other protective material.
- Do not use power tools when performing leveling procedure.

MATERIALS NEEDED

- $\frac{3}{8}$ " hex head driver
- Level

1. Remove toe grille and bottom bracket covers.

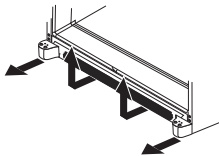

2. Turn both front adjustment screws (A) clockwise to raise and counterclockwise to lower.

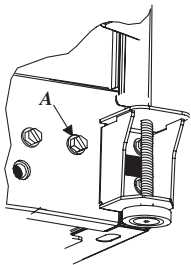

3. Turn both rear adjustment screws (B) clockwise to raise and counterclockwise to lower.

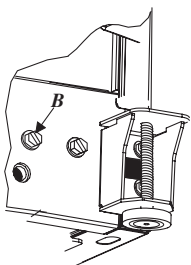

4. Turn stabilizing legs (C) clockwise until firmly against floor.
5. Turn front roller adjustment screws (A) 2 to 3 times counterclockwise, so that full weight of unit rests on stabilizing legs (C).

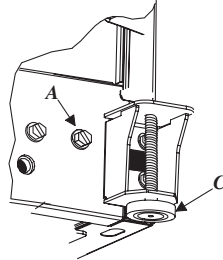

6. Using a level, make sure front of refrigerator is $\frac{1}{4}$ " (6 mm) or $\frac{1}{2}$ bubble higher than back of refrigerator. See leveling step 3 for assistance.
7. Replace toe grille and bracket cover(s). See markings on inside of toe grille to insure proper placement.

Snap bottom portion into place first. Press down on top part of grille until top portion snaps into place.

TEMPERATURE CONTROLS

The controls are located at the top front of the refrigerator and freezer compartments. **NOTE:** The freezer control turns the cooling system on. Neither section will cool if freezer control is set to off.

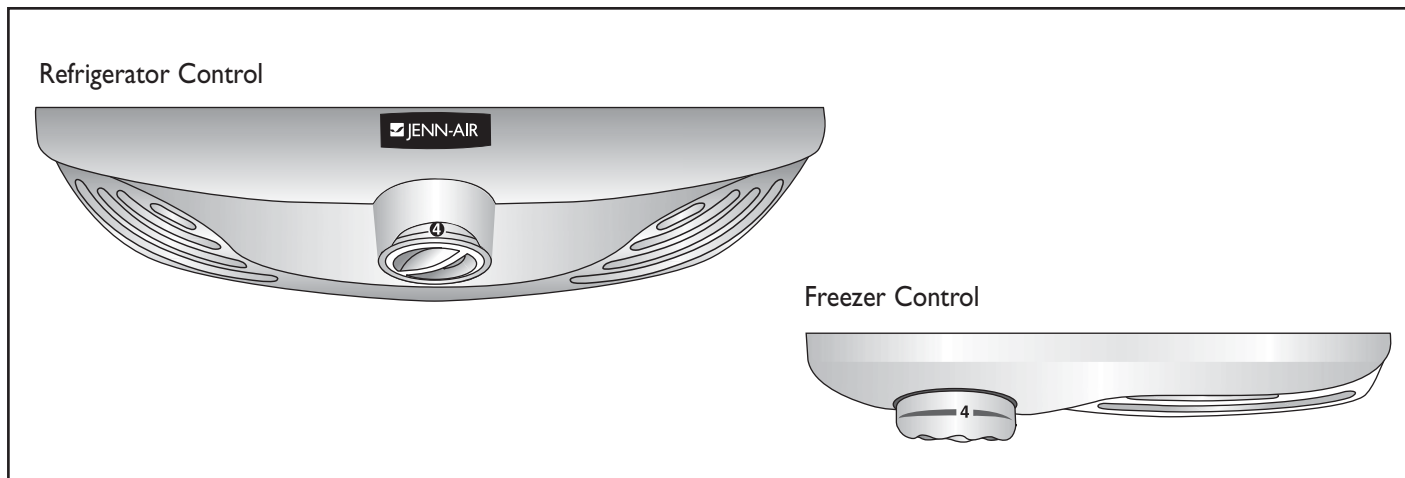

INITIAL CONTROL SETTINGS

After plugging the refrigerator in, set the controls.

- To adjust the controls, turn the control knob to the left or right as desired.
 - Initially set the refrigerator control on 4.
 - Initially set the freezer control on 4.
 - Let the refrigerator run at least 8-12 hours before adding food.

WARM CABINET SURFACES

At times, the front of the refrigerator cabinet may be warm to the touch. This is a normal occurrence that helps prevent moisture from condensing on the cabinet. This condition will be more noticeable when you first start the refrigerator, during hot weather and after excessive or lengthy door openings.

ADJUSTING THE CONTROLS

- Twenty-four hours after adding food, you may decide that one or both compartments should be colder or warmer. If so, adjust the control(s) as indicated in the table below.
- Do not change either control more than one number at a time when adjusting controls.
- Allow 5-8 hours for temperatures to stabilize.
- Changing either control will have some effect on the temperature of the other compartment.

TEMPERATURE CONTROL GUIDE

Refrigerator too warm	Turn the refrigerator control to next higher number.
Refrigerator too cold	Turn the refrigerator control to next lower number.
Freezer too warm	Turn the freezer control to next higher number.
Freezer too cold	Turn the freezer control to next lower number.
Turn refrigerator OFF	Turn the freezer control to OFF.

NOTE: Turning freezer control to OFF stops cooling in both compartments. It does not shut off power to the refrigerator.

FRESH FOOD COMPARTMENT

WATER DISPENSER (SOME MODELS)

A water dispenser is located on the left side wall of the fresh food section. This design is for cold water dispensing only.

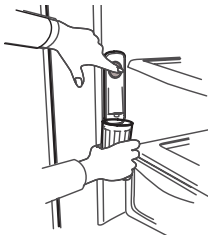

To dispense water:

- Hold container under spout and press dispenser pad, as illustrated.

INTERIOR SHELVES

⚠ CAUTION:

To avoid personal injury or property damage, observe the following:

- Confirm shelf is secure before placing items on shelf.
- Handle tempered glass shelves carefully. Shelves may break suddenly if nicked, scratched, or exposed to sudden temperature change.

SPILL-CATCHER™ SHELVES (SOME MODELS)

Spill-Catcher™ shelves feature the convenience of easy cleaning with a pullout design to reach items in the back. For ease of cleaning, glass shelf may be removed by pulling to full extension and lifting out of frame.

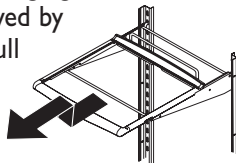

- To remove shelves, lift up and out.
- To install shelves, reverse above procedure.

REAR SHELF EXTENSIONS (SOME MODELS)

Rear Shelf Extensions help prevent articles from falling off the back of the shelf.

To remove and install shelf extension:

- To remove, pull extension straight up from rear of shelf.

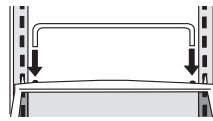

- To install, insert posts of the shelf extension into holes in the shelf frame.

DOOR STORAGE

DAIRY COMPARTMENT

The covered Dairy Compartment provides convenient storage for items such as butter, yogurt, cheese, etc. This compartment is an adjustable feature located in the door. It can be moved to several different locations to accommodate storage needs.

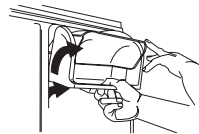

- To remove, open dairy door, pull upward and tilt out.
- To install, reverse above procedure.

DOOR BINS

Door Bins adjust to meet individual storage needs.

- To remove, slide bins up and pull straight out.
- To install, reverse above procedure.

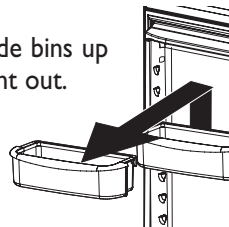

FULL WIDTH DOOR SHELF

The lower shelf on the door is full width and not adjustable.

To remove for cleaning:

- Lift shelf up and out.

To reinstall:

- Reverse above procedure.

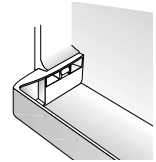

FRESH FOOD COMPARTMENT, CONT.

CLIMATE-CONTROLLED DRAWERS

CRISPER DRAWERS

The **Crispers** provide storage for fruit and vegetables. There is a humidity control located on the crisper shelf above each of the crisper drawers.

- For fruit storage, slide the crisper control toward the center to provide lower humidity conditions in the drawer.

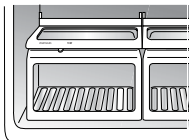

- For vegetable storage, slide the crisper control away from the center to provide higher humidity conditions in the drawer.

To remove and install crisper drawers:

- To remove drawer, pull drawer out to full extension. Tilt up front of drawer and pull straight out.

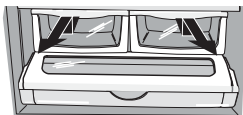

- To install, insert drawer into frame rails and push back into place.

GOURMET BAY™

The **Gourmet Bay™** provides a full-width drawer with a variable temperature control that keeps the compartment up to 5° F (3° C) colder than refrigerator temperature. This drawer can be used for large party trays, deli items, or beverages.

Gourmet Bay™ Control

The control, located on the right of the drawer, regulates the air temperature inside the drawer. Set control to 'cold' to provide normal refrigerator temperature. Use the 'coldest' setting for meats or other deli items.

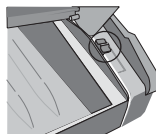

Note:

Cold air directed to the drawer can decrease refrigerator temperature. Refrigerator control may need to be adjusted.

To remove and install drawer:

- To remove drawer, pull drawer out to full extension. Tilt up front of pantry and pull straight out.

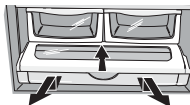

- To install, push metal glide rails to the back of the unit. Place drawer onto rails and slide drawer back until it falls into place.

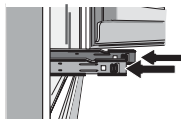

HOW DO I REMOVE THE GLASS AND CRISPER FRAME IF I WANT TO CLEAN IT?

- Remove the drawers as instructed at left.
- Place hand beneath frame to push up glass from underneath. Lift glass out.
- Lift frame from refrigerator liner rails.
- To install, repeat above instructions in reverse order.

ACCESSORIES

EGG CRADLE (SOME MODELS)

The **Egg Cradle** holds a "dozen plus" eggs. It can be removed to carry to a work area or to be washed.

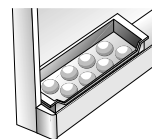

WINE TRIVET/CAN RACK (SOME MODELS)

The **Wine Trivet/Can Rack** accessory fits in the bottom of most drawer assemblies.

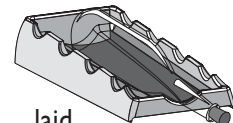

Bottles can be laid crosswise, or a single bottle may be laid in the center depression. Cans may also be stored horizontally.

GOURMET BAY™ DIVIDER (SOME MODELS)

The **Gourmet Bay™ Divider** is used to organize the Gourmet Bay™ into sections.

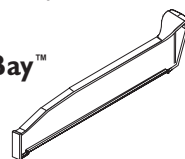

Note:

For easiest removal and replacement, remove drawer. If removal is not possible, pull drawer open to its fullest extension.

To remove and replace divider:

- To remove, raise front of divider to unhook divider from rear wall of drawer, and pull out.
- To install, hook back of divider over rear wall of drawer and lower into place.



GOURMET BAY™ TRAY

The **Gourmet Bay™ Tray** allows for a removable tray within the full-width storage drawer.

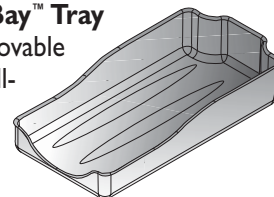

FREEZER COMPARTMENT

AUTOMATIC ICE MAKER (SOME MODELS)

⚠ CAUTION:

To avoid property damage, observe the following:

- Do not force ice maker arm down or up.
- Do not place or store anything in ice storage bin.

Using Ice Maker for the First Time

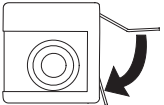
1. Confirm ice bin is in place and ice maker arm is down. 
2. After freezer section reaches between 0° to 2° F (-18° to -17° C), ice maker fills with water and begins operating.
3. Allow approximately 24 hours after installation to receive first harvest of ice.
4. Discard ice created within first 12 hours of operation to verify system is flushed of impurities.

Operating Instructions

1. Confirm ice bin is in place and ice maker arm is down.
2. After freezer section reaches 0° to 2° F (-18° to -17° C), ice maker fills with water and begins operating. You will have a complete harvest of ice approximately every 3 hours.
3. Stop ice production by raising ice maker arm until click is heard. 
4. Ice maker will remain in the off position until arm is pushed down.

DRAWERS

PULLOUT DRAWER BASKETS

(Door assembly of drawer removed from illustration for visual clarity)

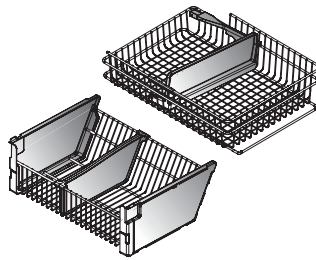

To remove and replace baskets:

- See page 7 for basket removal and replacement instructions.

⚠ DANGER:

To prevent accidental child entrapment or suffocation risk, DO NOT remove the divider in the top freezer basket.

ACCESSORIES

LOWER BASKET DIVIDER

The **Lower Basket Divider** allows the option to organize the basket area into sections.

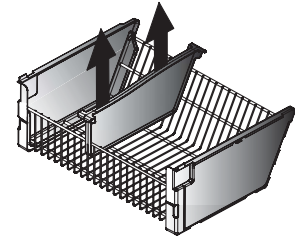

To remove and replace divider:

- To remove, pull divider straight up.
- To install, hook top corners of divider over top horizontal basket rungs.

ICE BIN (SOME MODELS)

The **Ice Bin** is useful storage for ice, frozen concentrate, etc.

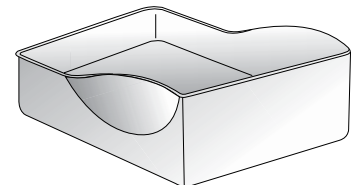

LOWER BASKET TRAY

The **Basket Tray** is a removable plastic item that rests on the bottom of the lower pullout basket to catch spills and small food items before they can fall through to the freezer compartment.

The tray can be removed for easy cleaning by lifting the tray from the basket.

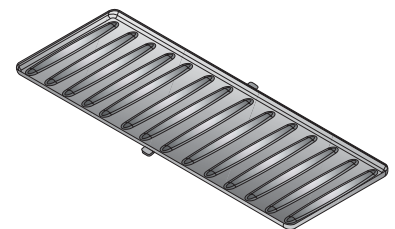

FILTRATION SYSTEM

WATER FILTER REMOVAL AND INSTALLATION

⚠ WARNING:

To avoid serious illness or death, do not use unit where water is unsafe or of unknown quality without adequate disinfection before or after use of filter.

⚠ CAUTION:

- Bypass cap **DOES NOT** filter water. Be sure to have replacement cartridge available when filter change is required.
- If water filtration system has been allowed to freeze, replace filter cartridge.
- If system has not been used for several months, and water has an unpleasant taste or odor, flush system by dispensing 2-3 glasses of water. If unpleasant taste or odor persists, change filter cartridge.

INITIAL INSTALLATION OF WATER FILTER

1. Remove blue bypass cap and retain for later use.

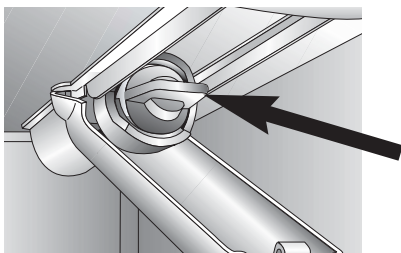

2. Remove sealing label from end of filter and insert into filter head.
 - Rotate gently clockwise until filter stops and snap filter cover closed.

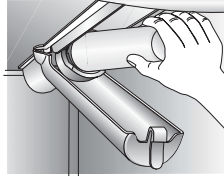

3. Reduce water spurts by flushing air from system. Run water continuously for 2 minutes through dispenser until water runs steady.
 - Additional flushing may be required in some households where water is of poor quality.

REPLACING WATER FILTER

IMPORTANT: Air trapped in system may cause water and cartridge to eject. Use caution when removing.

1. Turn filter counterclockwise until it releases from filter head.
2. Drain water from filter into sink and dispose in normal household garbage.
3. Wipe up excess water in filter cover.
4. Remove sealing label from end of filter and insert into filter head.
 - Rotate gently clockwise until filter stops and snap filter cover closed.
5. Reduce water spurts by flushing air from system. Run water continuously for 2 minutes through dispenser until water runs steady.
 - Additional flushing may be required in some households where water is of poor quality.

WHEN DO I CHANGE THE WATER FILTER?

Filter should be changed every 6 months.

IMPORTANT: Condition of water and amount used determines life span of water filter cartridge. If water use is high, or if water is of poor quality, replacement may need to take place more often.

HOW DO I ORDER A REPLACEMENT FILTER CARTRIDGE?

For OW51 replacement filter cartridges or for service, contact your dealer or Maytag Appliances Sales Company, Jenn-Air Customer Assistance, U.S. and Canada: 1-800-JENNAIR (1-800-536-6247).

I'M TRYING TO DISPENSE WATER TO FLUSH THE SYSTEM. WHERE'S THE WATER?

During initial use, allow about a 1- to 2-minute delay in water dispersal to allow internal water tank to fill.

WHAT IF I CHOOSE NOT TO USE THE WATER FILTRATION SYSTEM?

Dispenser feature may be used without water filter cartridge. If you choose this option, replace filter with blue bypass cap.

WATER FILTER DATA

SYSTEM SPECIFICATION AND PERFORMANCE DATA SHEET REFRIGERATOR WATER FILTER CARTRIDGE MODEL OWF51

Specifications

Service Flow Rate (maximum)	0.75 GPM (2.83 L/min)
Rated Service Life OWF50-NI300 (maximum).....	300 gallons/1135 liters
Rated Service Life OWF50-WI500 (maximum).....	500 gallons/1892 liters
Maximum Operating Temperature	100° F/38° C
Minimum Operating Temperature	33° F/1° C
Minimum Pressure Requirement	35 psi/138 kPa
Maximum Operating Pressure.....	120 psi/827 kPa

PERFORMANCE DATA

Substance	Influent Challenge Concentration	Effluent Average	Average % Reduction	Maximum Effluent	Min. Required Reduction	Inlet pH
Lead	0.15 mg/L +/- 10%	0.001 mg/L	99.33%	0.001 mg/L	0.010 mg/L	6.5
Lead	0.15 mg/L +/- 10%	0.002 mg/L	98.66%	0.003 mg/L	0.010 mg/L	8.5
Cyst	Minimum 50,000/L	1 count/mL	99.99%	3 count/mL	> 99.95%	NA
Turbidity	11 +/- 1 NTU	0.12 NTU	98.98%	0.18 NTU	0.5 NTU	NA
Lindane	0.002 mg/L +/- 10%	0.00005 mg/L	97.62%	0.00005 mg/L	0.00002 mg/L	NA
Atrazine	0.009 mg/L +/- 10%	0.0002 mg/L	97.93%	0.0006 mg/L	0.003 mg/L	NA
Chlorine	2.0 mg/L +/- 10%	0.09 mg/L	95.26%	0.17 mg/L	≥75%	NA
Particulate*	at least 10,000 particles/mL	900 count/mL	99.68%	2400 count/mL	≥85%	NA
2,4-D	0.210 mg/L +/- 10%	45.45 ug/L	84.42%	100 ug/L	0.0017 mg/L	NA
Asbestos	10 ⁷ to 10 ⁸ fibers/L; fibers greater than 10 micrometers in length	0.16 MFL/mL	99.96%	0.16 MFL/mL	99%	NA

Tested using a flow rate of 0.75 GPM (2.83 L/min.) and a maximum pressure of 120 psi (827 kPa) under standard laboratory conditions, however, actual performance may vary. Health Claim Performance tested and certified by NSF International

*Particle size range classification of test. Particles used were 0.5 – 1 microns.

State of California
Department of Health Services
Water Treatment Device
Certificate Number
01 - 1486

Date Issued: September 21, 2001
Date Revised: March 20, 2002

Trademark/Model Designation	Replacement Elements	Rated Capacity
WF50-WI500	WF50	500 gal
WF50-NI300	WF50	300 gal
WF50-KWI500	46 9005	500 gal
WF50-KNI300	46 9005	300 gal
OWF50-WI500	OWF51	500 gal
OWF50-NI300	OWF51	300 gal

Manufacturer: PentaPure Incorporated

The water treatment device(s) listed on this certificate have met the testing requirements pursuant to Section 116830 of the Health and Safety Code for the following health related contaminants:

Microbiological Contaminants and Turbidity	Inorganic/Radiological Contaminants
Cysts	Asbestos
	Lead
Organic Contaminants	
Atrazine	
Lindane	



Tested and certified by NSF International against ANSI/NSF Standards 42 and 53 in models OWF50-WI500 and OWF50-NI300 for the reduction of:

Standard No. 42: Aesthetic Effects

Taste and Odor Reduction
Chlorine Reduction
Mechanical Filtration Unit
Particulate Reduction Class I

Standard No. 53: Health Effects

Chemical Reduction Unit
Lead, Atrazine, Lindane and 2, 4-D Reduction
Mechanical Filtration Unit
Cyst, Turbidity and Asbestos Reduction



1000 Apollo Road
Eagan, Minnesota U.S.A.
EPA EST #35917-MN-1

GENERAL USE CONDITIONS

Read this Performance Data Sheet and compare the capabilities of this unit with your actual water treatment needs.

DO NOT use this product where water is microbiologically unsafe or of unknown quality without adequate disinfection before or after the system. System certified for cyst reduction may be used on disinfected water that may contain filterable cysts.

Use only with cold water supply. Check for compliance with the state and local laws and regulations.

The retractable water filtration system uses a OWF51 replacement cartridge. Timely replacement of filter cartridge is essential for performance satisfaction from this filtration system. Please refer to the applicable section in this owner's manual for general operation, maintenance requirements and troubleshooting.

Replacement Elements: OWF51

This system has been tested according to ANSI/NSF 42 and 53 for reduction of the substances listed below. The concentration of the indicated substances in water entering the system was reduced to a concentration less than or equal to the permissible limit for water leaving the system, as specified in ANSI/NSF 42 and 53.



HINTS AND CARE

CLEANING INSTRUCTIONS

⚠ WARNING:

To avoid electrical shock which can cause severe personal injury or death, disconnect power to refrigerator before cleaning. After cleaning, connect power.

⚠ CAUTION:

To avoid personal injury or property damage, observe the following:

- Read and follow manufacturer's directions for all cleaning products.
- **DO NOT** place buckets, shelves or accessories in dishwasher. Cracking or warping of accessories may result.

PART	DO NOT USE	DO
Textured Doors and Exterior Cabinet Interior	<ul style="list-style-type: none"> ➤ Abrasive or harsh cleaners ➤ Ammonia ➤ Chlorine bleach ➤ Concentrated detergents or solvents ➤ Metal or plastic-textured scouring pads 	<ul style="list-style-type: none"> ➤ Use 4 tablespoons of baking soda dissolved in 1 quart (1 liter) warm soapy water. ➤ Rinse surfaces with clean warm water and dry immediately to avoid water spots.
Stainless Steel Doors and Exterior IMPORTANT: <i>Damage to stainless steel finish due to improper use of cleaning products or non-recommended products is not covered under this product's warranty.</i>	<ul style="list-style-type: none"> ➤ Abrasive or harsh cleaners ➤ Ammonia ➤ Chlorine bleach ➤ Concentrated detergents or solvents ➤ Metal or plastic-textured scouring pads ➤ Vinegar-based products ➤ Citrus-based cleaners 	<ul style="list-style-type: none"> ➤ Use warm, soapy water and a soft, clean cloth or sponge. ➤ Rinse surfaces with clean warm water and dry immediately to avoid water spots.
Door Gaskets	<ul style="list-style-type: none"> ➤ Abrasive or harsh cleaners ➤ Metal or plastic-textured scouring pads 	
Condenser Coil <i>Remove base grille to access</i>		<ul style="list-style-type: none"> ➤ Use a vacuum cleaner hose nozzle.
Condenser Fan Outlet Grille <i>See back of refrigerator</i>		<ul style="list-style-type: none"> ➤ Use a vacuum cleaner hose nozzle with brush attachment.
Accessories <i>Shelves, buckets, drawers, etc.</i>	<ul style="list-style-type: none"> ➤ A dishwasher 	<ul style="list-style-type: none"> ➤ Follow removal and installation instructions from appropriate feature section. ➤ Allow items to adjust to room temperature. ➤ Dilute mild detergent and use a soft clean cloth or sponge for cleaning. ➤ Rinse surfaces with clean warm water. ➤ Dry glass and clear items immediately to avoid spots.

REMOVING ODORS FROM REFRIGERATOR

1. Remove all food.
2. Disconnect refrigerator.
3. Clean the following items using the appropriate instructions in the Care and Cleaning table on page 16.
 - Walls, floor and ceiling of cabinet interior
 - Drawers, shelves and gaskets according to the instructions in this section.
4. Pay special attention to clean all crevices by completing the following steps.
 - Dilute mild detergent and brush solution into crevices using a plastic bristle brush.
 - Let stand for 5 minutes.
 - Rinse surfaces with warm water. Dry surfaces with a soft, clean cloth.
5. Wash and dry all bottles, containers and jars. Discard spoiled or expired items.
6. Wrap or store odor-causing foods in tightly sealed containers to prevent reoccurring odors.
7. Connect power to refrigerator and return food to unit.
8. After 24 hours, check if odor has been eliminated.

If odor is still present:

1. Remove drawers and place on top shelf of refrigerator.
2. Pack refrigerator and freezer sections – including doors – with crumpled sheets of black and white newspaper.
3. Place charcoal briquettes randomly on crumpled newspaper in both freezer and refrigerator compartments.
4. Close doors and let stand 24-48 hours.

ENERGY SAVING IDEAS

- Avoid overcrowding refrigerator shelves. This reduces air circulation around food and causes refrigerator to run longer.
- Avoid adding too much warm food to unit at one time. This overloads compartments and slows rate of cooling.
- Do not use aluminum foil, wax paper, or paper toweling as shelf liners. This decreases air flow and causes unit to run less efficiently.
- A freezer that is $\frac{2}{3}$ full runs most efficiently.
- Locate refrigerator in coolest part of room. Avoid areas of direct sunlight, or near heating ducts, registers or other heat producing appliances. If this is not possible, isolate exterior by using a section of cabinet or an added layer of insulation.
- Refer to recommended control settings on page 10.
- Clean door gaskets every three months according to cleaning instructions on page 16. This will assure that door seals properly and unit runs efficiently.
- Take time to organize items in refrigerator to reduce time that door is open.
- Be sure your doors are closing securely by leveling unit as instructed on page 9.
- Clean condenser coils as instructed on page 16 every 3 months. This will increase energy efficiency and cooling performance.

REMOVE AND REPLACE LIGHT BULBS

⚠ WARNING:



To avoid electrical shock which can cause severe personal injury or death, disconnect power to refrigerator before replacing light bulb. After replacing light bulb, connect power.

⚠ CAUTION:

To avoid personal injury or property damage, observe the following:

- Allow light bulb to cool.
- Wear gloves when replacing light bulb.

FRESH FOOD SECTION

1. Slide shield toward back of compartment to release from light assembly. 
2. Remove light bulbs.
3. Replace with appliance bulbs **no greater than 40 watts**.
4. Replace light bulb cover by inserting tabs on light shield into liner holes on each side of light assembly. Slide shield toward front of unit until it locks into place. **DO NOT** force shield beyond locking point. Doing so may damage light shield. 

FREEZER

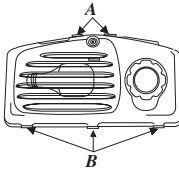
1. Pinch rear tabs on light cover and pull straight down.
2. Remove light bulb.
3. Replace bulb with appliance bulb **no greater than 40 watts**. 
4. Insert front tabs of light cover into freezer liner and snap rear portion over light assembly until rear tabs engage.

FOOD STORAGE TIPS

FRESH FOOD STORAGE

- The fresh food compartment of a refrigerator should be kept between 34° F and 40° F with an optimum temperature of 37° F. To check the temperature, place an appliance thermometer in a glass of water and place in the center of the refrigerator. Check after 24 hours. If the temperature is above 40° F adjust the controls as explained on page 10.
- Avoid overcrowding the refrigerator shelves. This reduces the circulation of air around the food and results in uneven cooling.

FRUITS AND VEGETABLES

- Storage in the crisper drawers traps moisture to help preserve the fruit and vegetable quality for longer time periods. (Refer to page 12).
- Sort fruits and vegetables before storage and use bruised or soft items first. Discard those showing signs of decay.
- Always wrap odorous foods such as onions and cabbage so the odor does not transfer to other foods.
- While vegetables need a certain amount of moisture to remain fresh, too much moisture can shorten storage times (especially leafy vegetables). Drain vegetables well before storing.

MEAT AND CHEESE

- Raw meat and poultry should be wrapped securely so leakage and contamination of other foods or surfaces does not occur.
- Occasionally mold will develop on the surface of hard cheeses (Swiss, Cheddar, Parmesan). Cut off at least an inch around and below the moldy area. Keep your knife or instrument out of the mold itself. The remaining cheese will be safe and flavorful to eat. Do **NOT** try to save individual cheese slices, soft cheese, cottage cheese, cream, sour cream or yogurt when mold appears.

DAIRY FOOD

- Most dairy foods such as milk, yogurt, sour cream and cottage cheese have freshness dates on their cartons for appropriate length of storage. Store these foods in the original carton and refrigerate immediately after purchasing and after each use.

FROZEN FOOD STORAGE

- The freezer compartment of a refrigerator should be kept at approximately 0° F. To check the temperature, place an appliance thermometer between the frozen packages and check after 24 hours. If the temperature is above 0° F, adjust the control as described on page 10.
- A freezer operates more efficiently when it is at least two-thirds full.

PACKAGING FOODS FOR FREEZING

- To minimize dehydration and quality deterioration use aluminum foil, freezer wrap, freezer bags or airtight containers. Force as much air out of the packages as possible and be sure they are tightly sealed. Trapped air can cause the food to dry out, change color and develop an off-flavor (freezer burn).
- Overwrap fresh meats and poultry with suitable freezer wrap prior to freezing.
- **Do not refreeze meat that has completely thawed.**

LOADING THE FREEZER

- Avoid adding too much warm food to the freezer at one time. This overloads the freezer, slows the rate of freezing and can raise the temperature of frozen foods.
- Leave space between the packages so cold air can circulate freely, allowing food to freeze as quickly as possible.

Refer to the Food Storage Chart on page 19 for approximate storage times.

FOOD STORAGE CHART

(Storage times are approximate and may vary depending on type of packaging, storage temperature, and the quality of the food when purchased.)

Foods	Refrigerator	Freezer	Storage Tips
DAIRY PRODUCTS			
Butter	1 month	6-9 months	Wrap tightly or cover.
Milk & cream	1 week	Not recommended	Check carton date. Close tightly. Don't return unused portions to original container. Don't freeze cream unless whipped.
Cream cheese, cheese spread & cheese food	1-2 weeks	Not recommended	Wrap tightly.
Cottage cheese	3-5 days	Not recommended	Store in original carton. Check carton date.
Sour cream	10 days		
Hard cheese (Swiss, Cheddar & Parmesan)	1-2 months	4-6 months May become crumbly	Wrap tightly. Cut off any mold.
EGGS			
Eggs in the shell	3 weeks	Not recommended	Refrigerate small ends down.
Leftover yolks or whites	2-4 days	9-12 months	For each cup of yolks to be frozen, add 1 tsp. sugar for use in sweet, or 1 tsp. salt for non-sweet dishes.
FRUITS			
Apples	1 month	8 months (cooked)	May also store unripe or hard apples at 60-70° F.
Bananas	2-4 days	6 months (whole/peeled)	Ripen at room temperature before refrigerating. Bananas and avocados darken when refrigerated.
Pears, plums, avocados	3-4 days	Not recommended	
Berries, cherries, apricots	2-3 days	6 months	
Grapes	3-5 days	1 month (whole)	
Citrus fruits	1-2 weeks	Not recommended	May also store at 60-70° F. If refrigerated, store uncovered.
Pineapples, cut	2-3 days	6-12 months	Will not ripen after purchase. Use quickly.
VEGETABLES			
Asparagus	1-2 days	8-10 months	Do not wash before refrigerating. Store in crisper.
Brussels sprouts, broccoli, cauliflower, green peas, lima beans, onions, peppers	3-5 days	8-10 months	Wrap odorous foods. Leave peas in pods.
Cabbage, celery	1-2 weeks	Not recommended	Wrap odorous foods & refrigerate in crisper.
Carrots, parsnips, beets, & turnips	7-10 days	8-10 months	Remove tops. Wrap odorous foods and refrigerate in the crisper.
Lettuce	7-10 days	Not recommended	
POULTRY & FISH			
Chicken and Turkey, whole	1-2 days	12 months	Keep in original packaging for refrigeration. Place in the Meat and Cheese Drawer. When freezing longer than 2 weeks, overwrap with freezer wrap.
Chicken and Turkey, pieces	1-2 days	9 months	
Fish	1-2 days	2-6 months	
MEATS			
Bacon	7 days	1 month	Fresh meats can be kept in original packaging for refrigeration. Place in the Meat and Cheese Drawer. When freezing longer than 2 weeks, overwrap with freezer wrap.
Beef or lamb, ground	1-2 days	3-4 months	
Beef or lamb, roast & steak	3-5 days	6-9 months	
Ham, fully cooked, whole	7 days	1-2 months	
half	5 days	1-2 months	
slices	3 days	1-2 months	Unopened, vacuum-packed luncheon meat may be kept up to 2 weeks in the Meat and Cheese Drawer.
Luncheon meat	3-5 days	1-2 months	
Pork, roast	3-5 days	4-6 months	
Pork, chops	3-5 days	4 months	
Sausage, ground	1-2 days	1-2 months	
Sausage, smoked	7 days	1-2 months	
Veal	3-5 days	4-6 months	Processed meats should be tightly wrapped and stored in the Meat and Cheese Drawer.
Frankfurters	7 days	1 month	

Sources: United States Department of Agriculture; Food Marketing Institute; Cooperative Extension Service, Iowa State University

NORMAL OPERATING SOUNDS

Today's refrigerators have new features and are more energy efficient. Foam insulation is very energy efficient and has excellent insulating capabilities, however, foam insulation is not as sound absorbent. As a result, certain sounds may be unfamiliar. In time, these sounds will become familiar. Please refer to this information before calling service.

TOPIC	POSSIBLE CAUSE	SOLUTION
Clicking	➤ Freezer control (A) clicks when starting or stopping compressor.	➤ Normal operation
	➤ Defrost timer (B) sounds like an electric clock and snaps in and out of defrost cycle.	➤ Normal operation
Air rushing or whirring	➤ Freezer fan (C) and condenser fan (D) make this noise while operating.	➤ Normal operation
Gurgling or boiling sound	➤ Evaporator (E) and heat exchanger (F) refrigerant makes this noise when flowing.	➤ Normal operation
Thumping	➤ Ice cubes from ice maker (select models) drop into ice bucket (G) .	➤ Normal operation
Vibrating noise	➤ Compressor (H) makes a pulsating sound while running.	➤ Normal operation
	➤ Refrigerator is not level.	➤ See Installation Instructions for details on how to level your unit.
Buzzing	➤ Ice maker water valve (I) hookup (select models) buzzes when ice maker fills with water.	➤ Normal operation
Humming	➤ Ice maker (J) is in the 'on' position without water connection.	➤ Stop sound by raising ice maker arm to 'off' position. See <i>Automatic Ice Maker</i> section in your Owner's Manual for details.
	➤ Compressor (H) can make a high-pitched hum while operating.	➤ Normal operation
Hissing or popping	➤ Defrost heater (K) hisses, sizzles or pops when operational.	➤ Normal operation

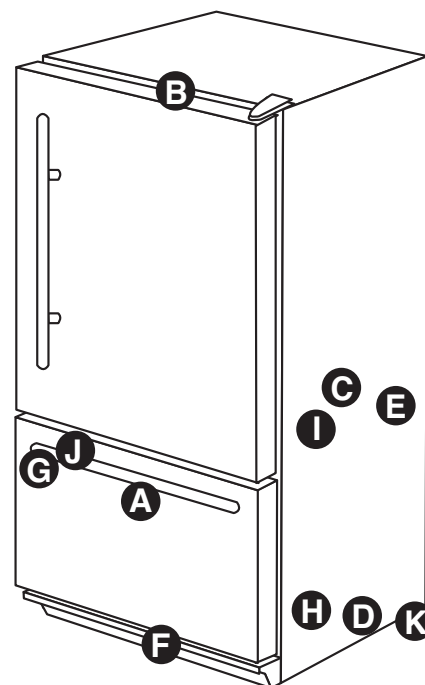

BEFORE YOU CALL FOR SERVICE

Review this chart of troubleshooting tips first...you may not need to call for service at all.

	PROBLEM	POSSIBLE CAUSES	WHAT TO DO
GENERAL OPERATION	Freezer control and lights are on, but compressor is not operating	Refrigerator is in defrost mode.	Normal operation. Wait 40 minutes to see if refrigerator restarts.
	Refrigerator does not operate	Refrigerator is not plugged in.	Plug in unit.
		Freezer control is not on.	See page 10.
		Fuse is blown, or circuit breaker needs to be reset.	Replace blown fuses. Reset circuit breaker.
		Power outage has occurred	Call local power company listing to report outage.
	Refrigerator still won't operate	Unit is malfunctioning.	Unplug refrigerator and transfer food to another refrigerator. If another unit is not available, place dry ice in freezer section to preserve food. Warranty does not cover food loss. Contact service for assistance.
	Refrigerator has an odor	Compartment is dirty or has odor-causing food.	See page 17.
	Crisper drawers do not close freely	Contents of drawer, or positioning of items in the surrounding compartment could be obstructing drawer.	Reposition food items and containers.
		Drawer is not in proper position.	See page 12 for proper crisper placement.
		Refrigerator is not level.	See page 9.
Drawer channels are dirty or need treatment.		Clean drawer channels with warm, soapy water. Rinse and dry. Apply a thin layer of petroleum jelly to drawer channels.	
Refrigerator runs too frequently	Doors have been opened frequently or for long periods of time.	Minimize door openings.	
	Humidity or heat in surrounding area is high.	Normal operation.	
	Food has recently been added.	Allow time for recently added food to reach refrigerator or freezer temperature.	
	Refrigerator is exposed to heat by environment or by appliances nearby.	Evaluate your refrigerator's environment. Refrigerator may need to be moved to run more efficiently.	
	Condenser coils are dirty.	Clean according to cleaning instructions. See page 16.	
	Controls need to be adjusted.	See page 10.	
	Door is not closing properly.	Refrigerator is not level. See page 9.	
	Today's refrigerators start and stop more often to maintain even temperatures.	Check gaskets for proper seal. Clean, if necessary. See page 16. Check to see if something is preventing door from closing.	
NOISE	Noise, sounds and vibrations	Normal operation.	See page 20.
		Cabinet not level.	Level cabinet. See page 9.
TEMPERATURE	Food temperature is too cold	Condenser coils are dirty.	Clean according to cleaning instructions. See page 16.
		Refrigerator or freezer controls are set too high.	See page 10.
	Food temperature is too warm	Door is not closing properly.	Refrigerator is not level. See page 9. Check gaskets for proper seal. Clean, if necessary. See page 16. Check to see if something is preventing door from closing.
		Controls need to be adjusted.	See page 10.
		Condenser coils are dirty.	Clean according to cleaning instructions. See page 16.
		Rear air grille is blocked.	Check the positioning of food items in refrigerator to make sure grille is not blocked. Rear air grilles are located under crisper drawers.
		Prolonged door openings.	Minimize door openings.



BEFORE YOU CALL FOR SERVICE, CONT.

	PROBLEM	POSSIBLE CAUSES	WHAT TO DO
ICE	Refrigerator is leaking water	Plastic tubing was used to complete water connection.	Use copper tubing for installation. Plastic is less durable and can cause leakage.
	Ice forms in inlet tube to ice maker	Improper water valve was installed.	Check water connection procedure in the Installation Instructions. Self-piercing and $\frac{3}{16}$ " saddle valves cause low water pressure and may clog the line over time.
		Water pressure is low.	Water pressure must be between 20 to 100 pounds per square inch to function properly.
	Water flow is slower than normal	Freezer temperature is too high.	See page 7. Freezer temperature should be approximately 0° F (-18° C).
		Water pressure is low.	Water pressure must be between 20 to 100 pounds per square inch to function properly.
		Improper water valve was installed.	Check water connection procedure in the Installation Instructions. Self-piercing and $\frac{3}{16}$ " saddle valves cause low water pressure and may clog the line over time.
MOISTURE	Water droplets form on outside of refrigerator	Check gaskets for proper seal.	Clean, if necessary. See page 16.
		Humidity levels are high.	Normal during times of high humidity.
		Controls require adjustment.	See page 10.
	Water droplets form on inside of refrigerator	Humidity levels are high or door has been opened frequently.	Minimize door openings.
Check gaskets for proper seal.		Clean, if necessary. See page 16.	

REFRIGERATOR WARRANTY

Full One Year Warranty

For **one (1) year** from the date of original retail purchase, any part which fails in normal home use will be repaired or replaced free of charge.

Ice Maker – when purchased with the refrigerator and installed by the dealer the ice maker will be considered part of the refrigerator for warranty purposes.

Limited Warranty — Major Refrigeration Components

Second thru Fifth Year:

After the first year from the date of original retail purchase, through the end of the fifth year, Maytag Appliances will repair or replace, at its option, free of charge for parts and labor, any part of the sealed refrigeration system (consisting of the compressor, evaporator, condenser, drier and connecting tubing) and the cabinet liner (exclusive of the door liner) which fail in normal home use. Mileage and transportation charges, if required, shall be the responsibility of the owner.

Limited Warranty — Water Filter:

With regard to the water filter cartridge, Maytag Appliances will replace any part of the water filter cartridge which fails due to a defect in workmanship or materials, *for a period of Thirty Days from the date of original purchase*. This is a full 30 day warranty, and during this warranty period we will also provide free of charge, all labor and in-home service required to replace the defective part.

Limited Warranty — Other Parts:

Second Year:

Parts other than major refrigeration components which fail in normal home use during the second year following the date of original retail purchase will be repaired or provided free of charge for the part itself, with the owner paying all other costs, including labor, mileage and transportation.

Please note: The full warranty and the limited warranties apply when the refrigerator is located in the United States or Canada. Refrigerators located elsewhere are covered by the limited warranties only including parts that fail during the first year.

LIMITATIONS OF LIABILITY

The warrantor shall not be liable for any incidental or consequential damages, including food loss. Some states do not allow the exclusion or limitation of consequential damages, so the above limitation or exclusion may not apply to you.

The specific warranties expressed above are the ONLY warranties provided by the manufacturer. This warranty gives you specific legal rights, and you may also have other rights that vary from state to state.

WHAT IS NOT COVERED BY THESE WARRANTIES:

1. Conditions and damages resulting from any of the following:
 - a. Improper installation, delivery, or maintenance.
 - b. Any repair, modification, alteration or adjustment not authorized by the manufacturer or an authorized servicer.
 - c. Misuse, abuse, accidents, or unreasonable use.
 - d. Incorrect electric current, voltage or supply.
 - e. Improper setting of any control.
2. Warranties are void if the original serial numbers have been removed, altered, or cannot be readily determined.
3. Light bulbs.
4. Products purchased for commercial or industrial use.
5. The cost of service or service call to :
 - a. Correct installation errors.
 - b. Instruct the user on proper use of the product.
 - c. Transport the appliance to the servicer.
6. Consequential or incidental damages sustained by any person as a result of any breach of these warranties.

Some states do not allow the exclusion or limitation of consequential or incidental damages, so the above exclusion may not apply.

TO RECEIVE WARRANTY SERVICE

To locate an authorized service company in your area contact the Jenn-Air dealer from whom your appliance was purchased; or call Maytag Appliances Sales Company, Jenn-Air Customer Assistance at the number listed below. Should you not receive satisfactory warranty service, please call or write:

Maytag Appliances Sales Company
Attn: CAIR® Center
P.O. Box 2370
Cleveland, TN 37320-2370

U.S. and CANADA 1-800-JENNAIR (1-800-536-6247)
U.S. customers using TTY for deaf, hearing impaired or speech impaired, call 1-800-688-2080.

NOTE: When writing about an unsolved service problem, please include the following information:

- (a) Your name, address and telephone number;
- (b) Model number, serial number, and revision number (found on the top front interior of the refrigerator compartment);
- (c) Name and address of your dealer and the date the appliance was bought;
- (d) A clear description of the problem you are having.
- (e) Proof of purchase (sales receipt).

User's Guides, service manuals and parts catalogs are available from Maytag Appliances Sales Company, Jenn-Air Customer Assistance.



Jenn-Air • 403 West Fourth Street North • P.O. Box 39 • Newton, Iowa 50208

