

# WINDTUNNEL™ UPRIGHT

The WindTunnel™ series of uprights was first introduced in mid 1997. Four deep wine colored models comprised the line and all were similar in overall appearance like the one in Figure 1.

Features included on the various models:

- 13" and 15" nozzles
- Embedded dirt finder (two models)
- Cords 31' and 35'
- Bag check indicator (three models)
- Agitator, replaceable roll sleeve type
- Headlight, one 12 volt 27313101
- Flat belt 38528033
- Hard bag enclosure
- One speed motor
- Stair cleaning handle
- Four position height adjustment
- Tool storage on the cleaner
- Micro-filtration throw away bags Type "Y"
- Bag check indicator (three models)
- 4, 5 or 6 stage filtration
- Edge cleaning "Edgers"
- Rotating top cord hook
- 10' and 12' hose reach

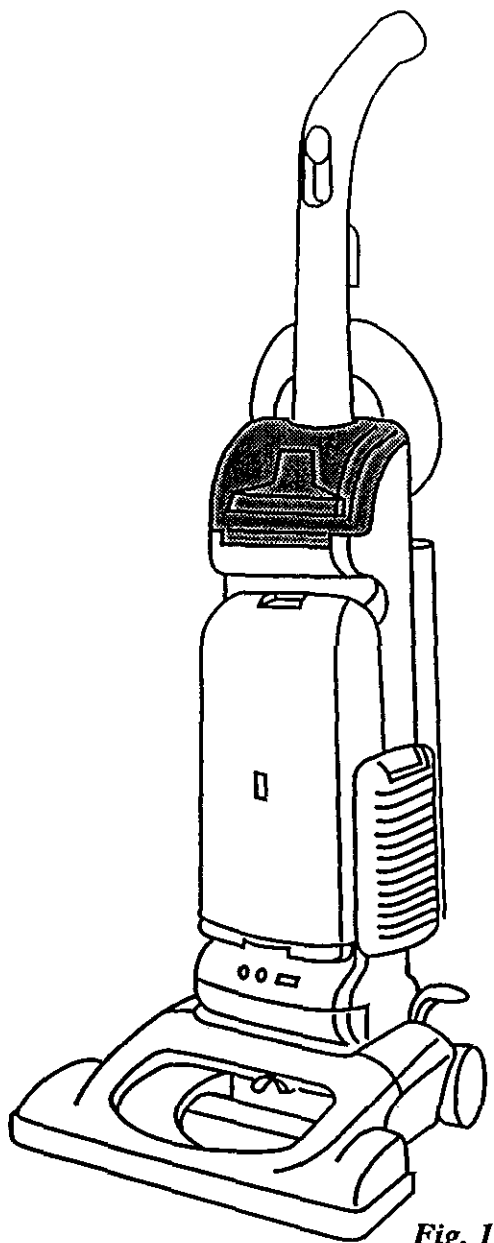

These cleaners operate on a clean air principle, i.e., where the dirty air enters the bag or dirt receptacle before it goes past the motor area. Since the same air is used to cool the motor, it is extremely important that it be filtered adequately to prevent dirt and dust from getting into the motor and/or back into the room.

**Basic operation** of the clean air system in these units is illustrated in Figure 2 on page 2.

**Air flow in the WindTunnel** is shown in Figure 2A on page 2.

# Air Flow

 Dirty Air

 Filtered Air

 Clean Air

 Filters

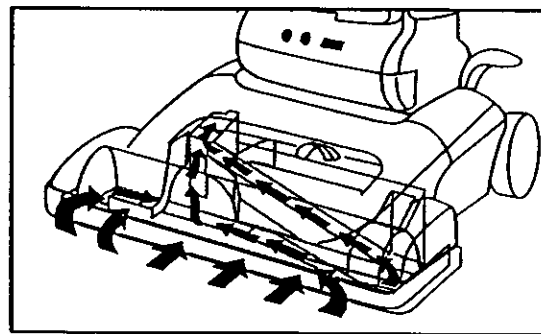
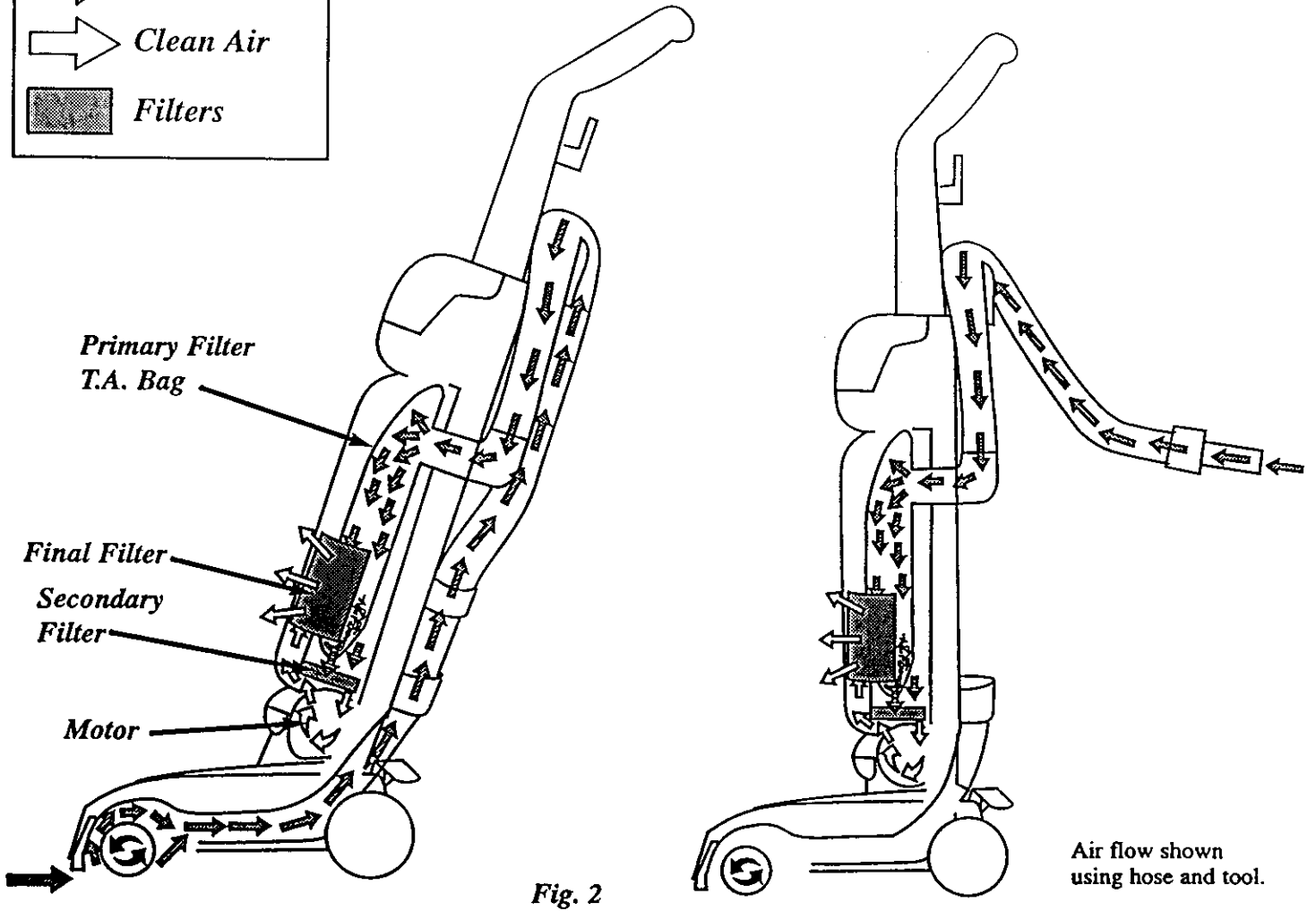

Fig. 2A

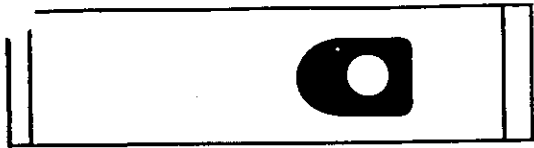

Fig. 3

**TYPE "Y" MICRO-FILTRATION** throw away bags are specified on all models as the primary (2 stage) filter **Figure 3**.

Secondary filters are located behind a grill in the bottom of the bag cavity **Figure 4**.

They can be washed and reinstalled when completely dry or replaced with new ones.

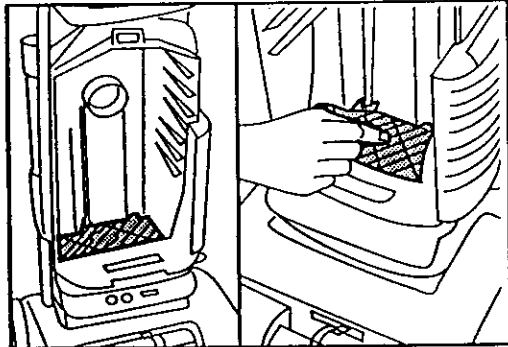

Fig. 4

Final filters are located on the side of the bag housing **Figure 5**. They too are washable and/or replaceable, and made in 1, 2 or 3 layers.

**Nozzle height** is adjusted on the front of the unit and ranges from high, for very deep pile carpet, to bare floor on the lowest setting **Figure 6**.

An **Embedded Dirt Finder™ (EDF)** feature is on some models. The control circuit for this feature is directly wired and **does not require a battery**.

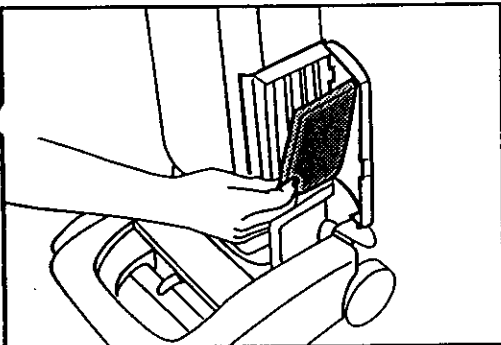

Fig. 5

Red and green lights (A in **Figure 7**) signal the user that the system is working. The red light comes on when the cleaner is first energized then goes off and the green one comes on to let the user know when to begin cleaning. While cleaning, a red light indicates that embedded dirt is being removed from the carpet. When the light turns green the carpet is clean.

A sensitivity switch near the light allows the user to increase or decrease the units sensitivity to dirt (B in **Figure 8**). "Hi" increases sensitivity, "Reg" decreases it.

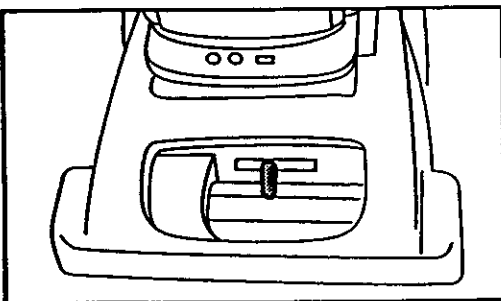

Fig. 6

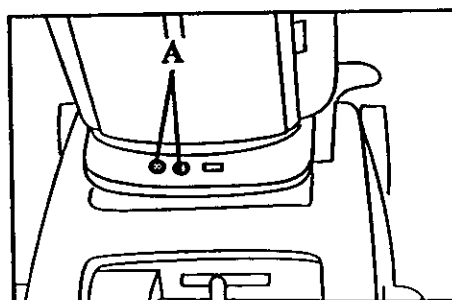

Fig. 7

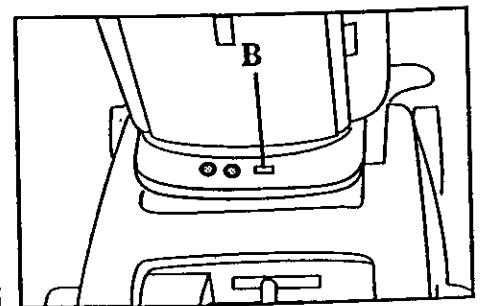

Fig. 8

Key components of a deluxe WindTunnel model are shown in Figure 9.

Refer to the Hoover Service Manual for repair procedures and the Microfiche Parts Catalog light brown header for spare parts.

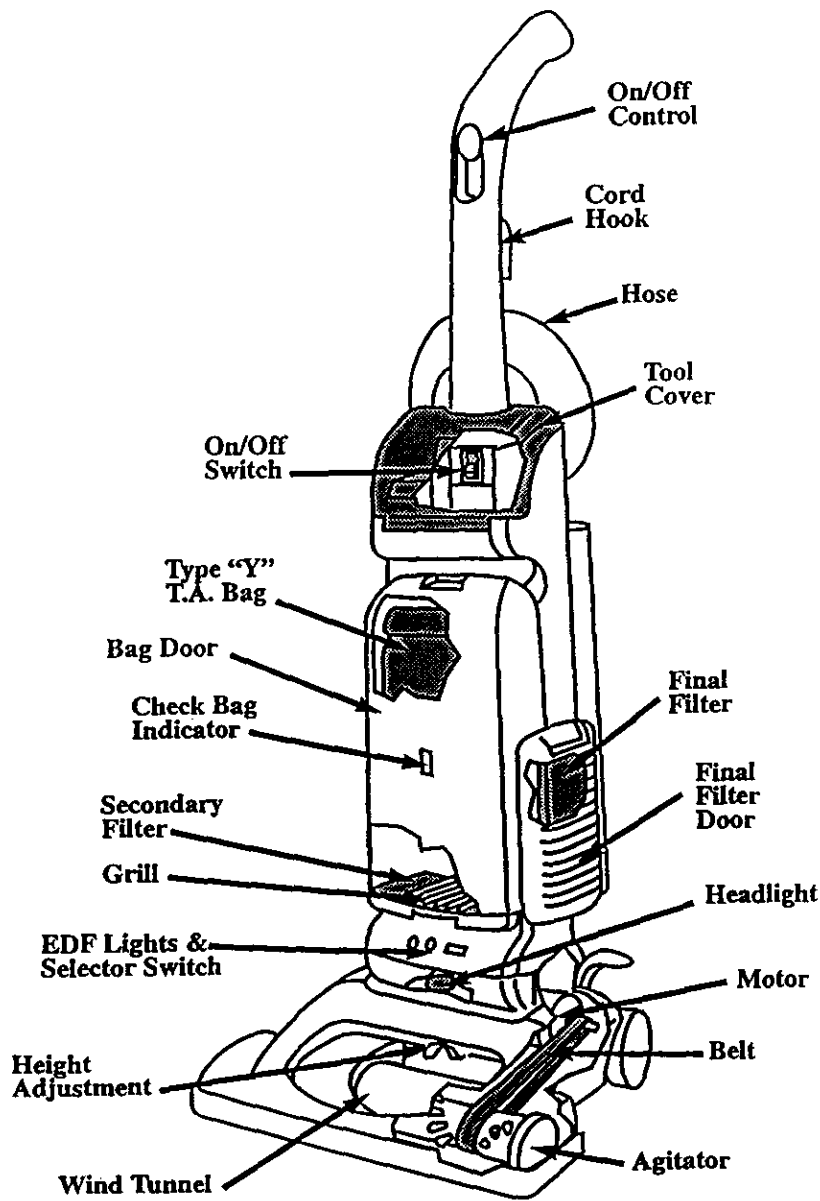

Fig. 9



Service Instructions  
WindTunnel Uprights



Service Support. 7/97

# WindTunnel w/o EDF

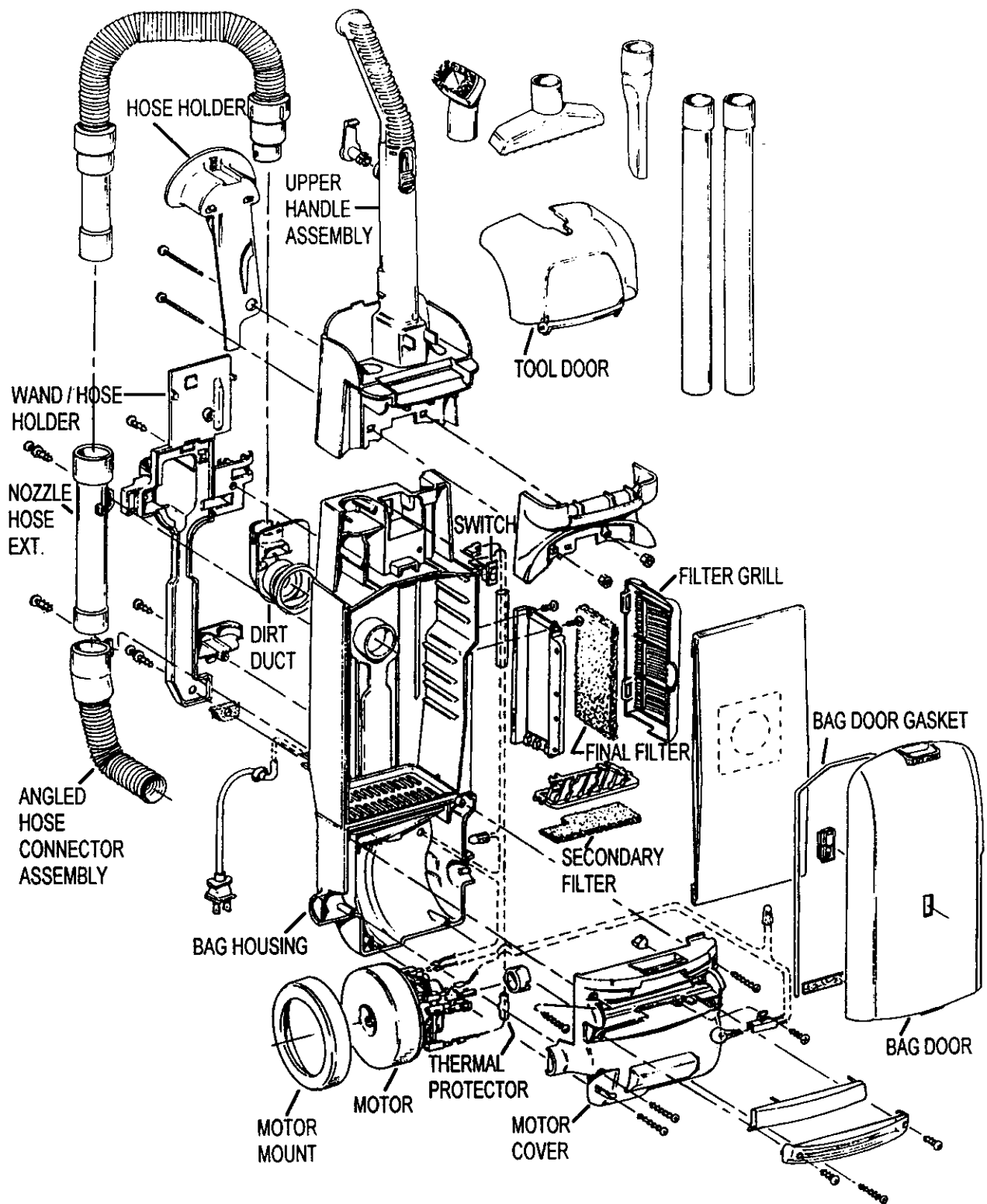

# WindTunnel w/EDF

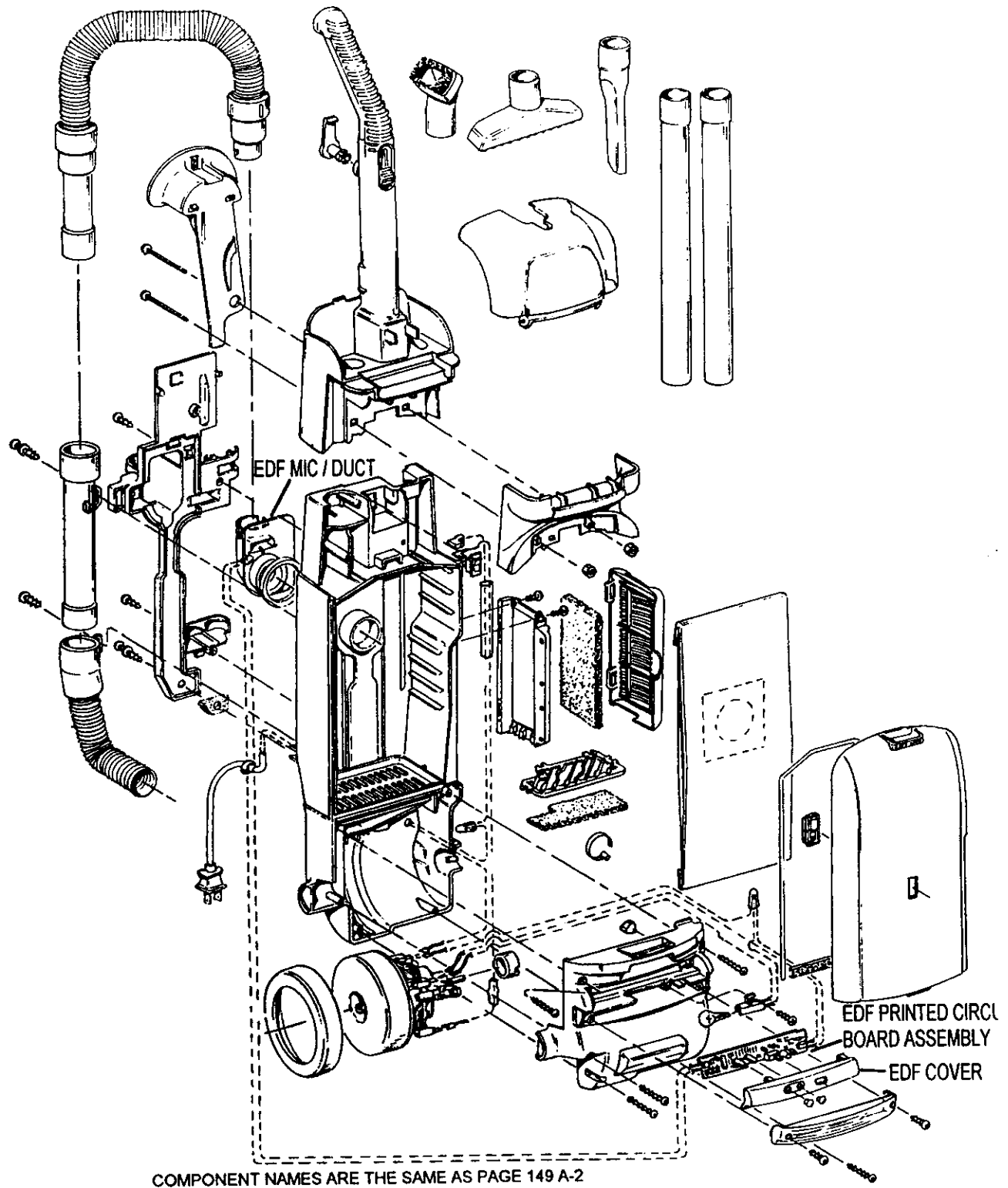

COMPONENT NAMES ARE THE SAME AS PAGE 149 A-2  
EXCEPT THOSE LISTED

# WindTunnel - 13" & 15" Width (Half Hood)

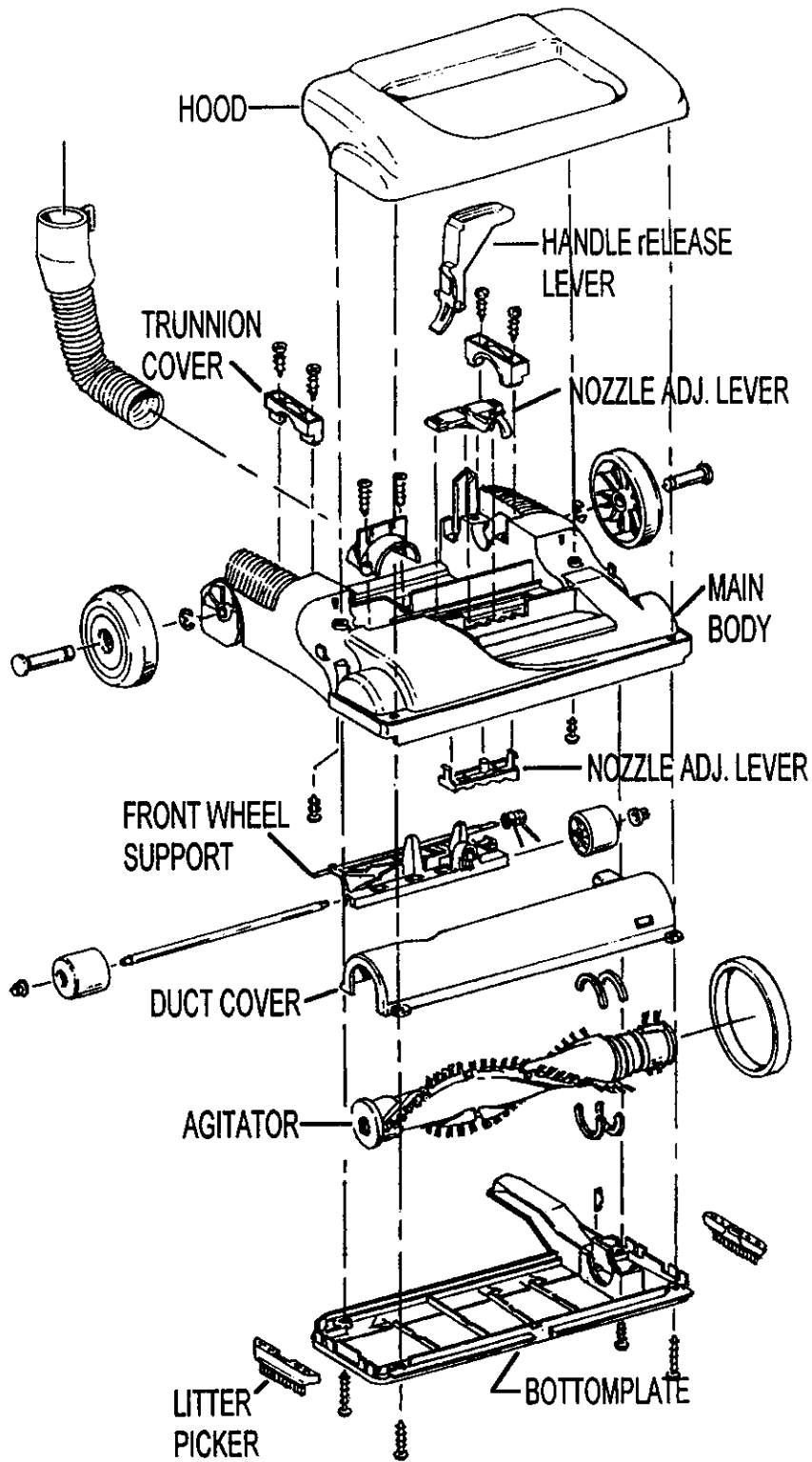

# WindTunnel - 13" & 15" Width (Full Hood)

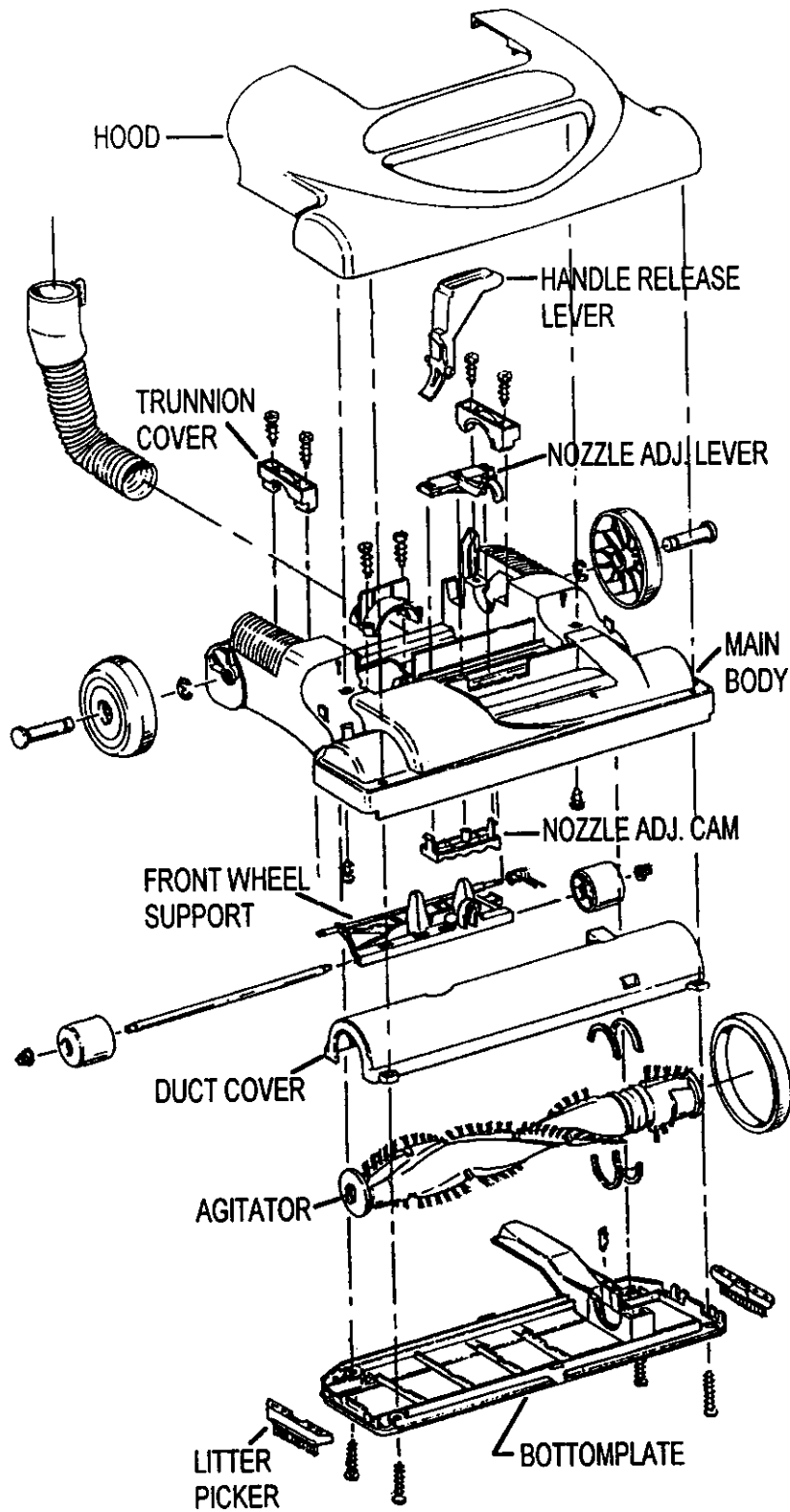

## I. General

The WindTunnel cleaners are upright vacuums that feature computer designed air vanes to provide a powerful dual air stream which dramatically improves dirt pickup capabilities.

These cleaners also come in 13" and 15" widths and feature on board tool storage and fast easy above floor cleaning. Some models feature the Embedded Dirt Finder, Bag Check Indicator, Edge Cleaning Edgers "Litter Pickers", 10' and 12' hose reach (upper end models include an extra 20' reach hose).

All models feature type "Y" allergen top fill disposable bags. Low end units include a 4 stage filtration system and as the line progresses 5 and 6 stage filtration systems are utilized.

## II. Basic Operation

These cleaners operate on a clean air principle, i.e., where the dirty air enters the bag or dirt receptacle before it goes past the motor area. Since the same air is used to cool the motor, it is extremely important that it be filtered adequately to prevent dirt and dust from getting into the motor and/or back into the room.

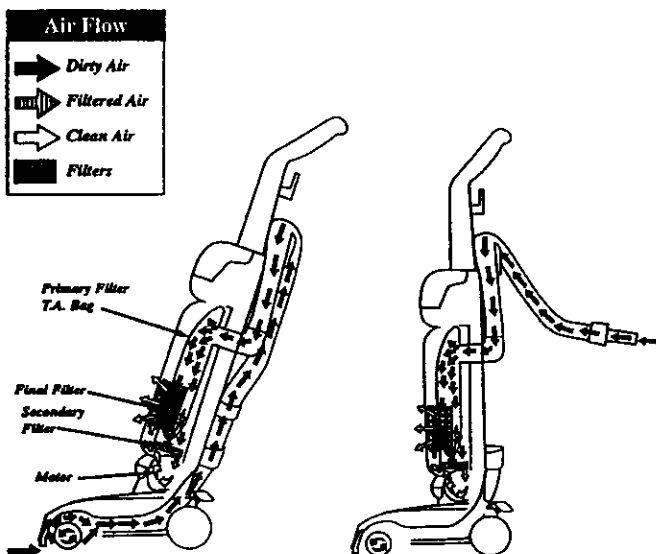

## III. Disassembly

### A. Bottom Plate - Agitator - Belt

1. Remove 4 screws and lift off bottom plate (Fig. 1).

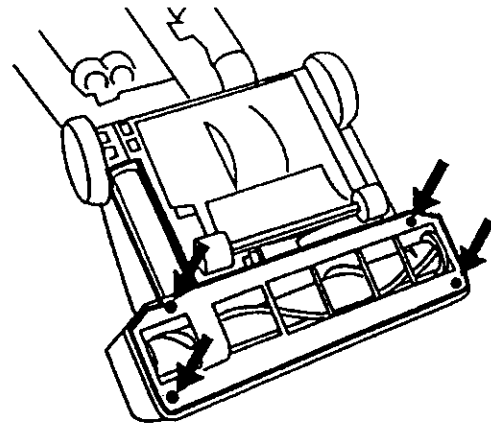

Fig. 1

Rubber edge groomers on bottom plate are replaceable to remove slide off of plate (Fig. 2).

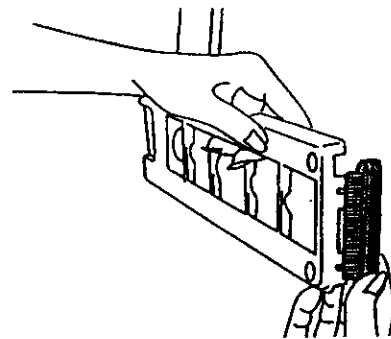

Fig. 2

2. Remove agitator and belt.

To service agitator, consult the agitator section of the service manual.

## B. Duct Cover

1. Slide out of main body (Held into place by bottom plate screws). (Fig. 3).

Fig. 3

## C. Front Wheels and Wheel Support

1. Pry spring leg up and out of track in wheel support (Fig. 4)

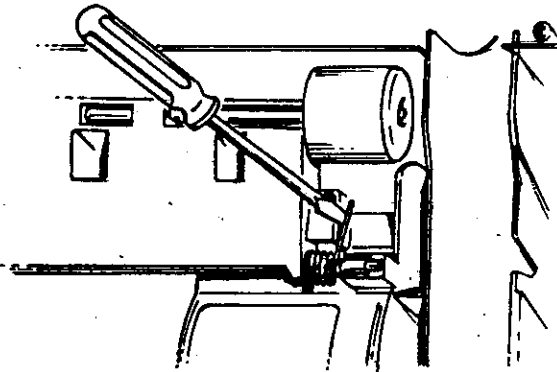

Fig. 4

2. Pivot wheel support up and out of main body.

To reassemble:

Position spring on wheel support with the long leg inward.

Position spring so that longest leg slides into slot on main body (Fig. 5).

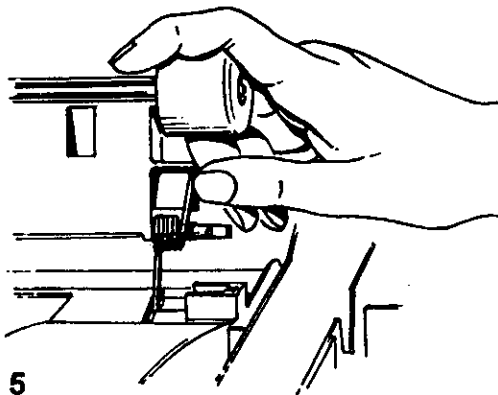

Fig. 5

Pull short leg of spring backward and hook into track on wheel support.

Wheels and wheel shaft can be replaced by removing plastic wheel retainers. Note: Once wheel retainers are removed they should be replaced.

## D. Hood

Remove 2 screws (Fig. 6) and remove hood.

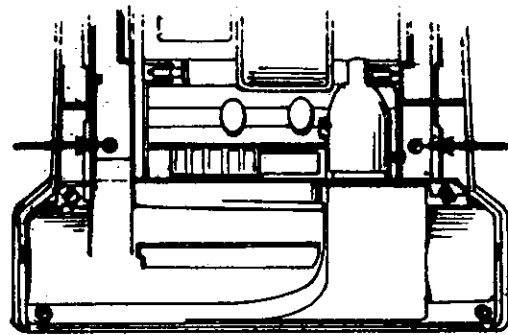

Fig. 6

## E. Height Adjustment Lever

1. Release two locking tabs and separate cam and lever (Fig. 7).

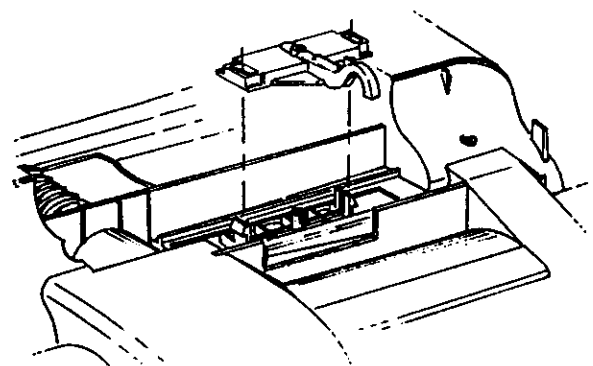

Fig. 7

Note the position of cam for proper reassembly

Improper assembly will cause the lever to lock into position.

### F. Main Body

1. Remove two R.H. and two L.H. trunnion screws - marked "A" (Fig. 9)

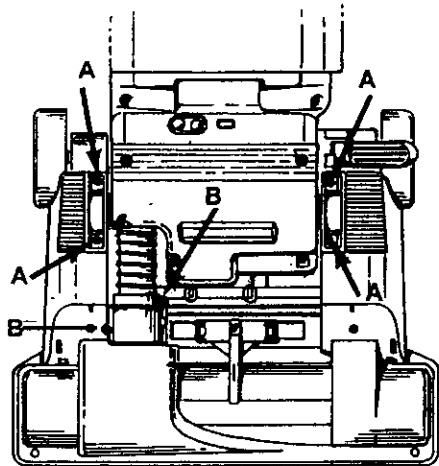

Fig. 9

2. Remove hose clamp - two screws ("B") (Fig. 9)

Lift entire upper assembly up and off of main body.

### G. Handle Release Lever

Snap fit into base. Pivot lever inward and work a screwdriver in behind to release tabs. Slide lever out of main body.

### H. Rear Wheels

Remove "E" clips and slide shaft out of main body (Fig. 10).

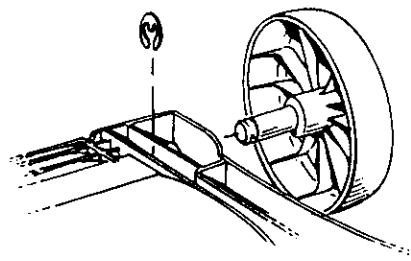

Fig. 10

### I. Hose

Hose is replaced as an assembly.

1. Twist hose connector to unlock from duct assembly and remove (Fig. 11).

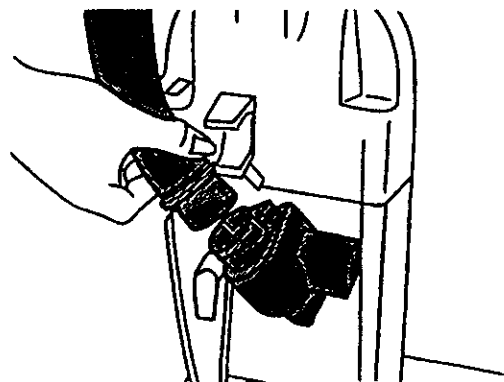

Fig. 11

### J. Nozzle Hose Extension (Where Applicable)

1. Remove screw.
2. Pivot clockwise and remove.

### K. Angled Hose Conn. Assembly.

1. Remove screw (Fig. 12).

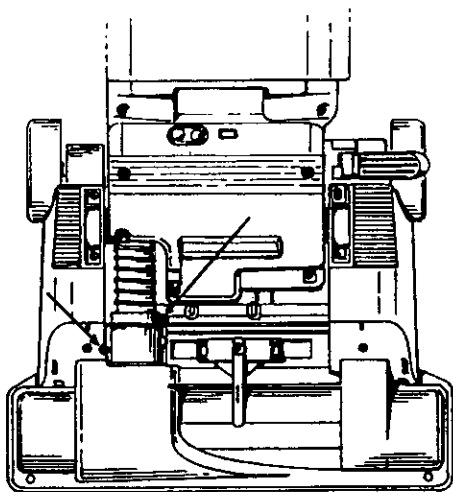

Fig. 12

### L. Upper Handle

Replaces as an assembly.

1. Remove two bolts and lift off of bag housing. (Fig. 13).

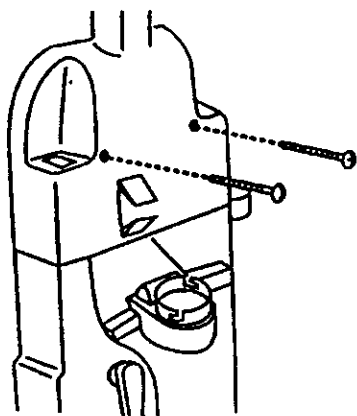

Fig. 13

### M. Filter Holder

Deluxe, Plus and Supreme models:

1. Remove two screws which secures holder to bag housing and lift off.

Standard Models:

1. Trapped into position by motor cover.

### N. Wand/Hose Holder

Models with "up front" tool storage.

1. Remove three screws (Fig. 14).

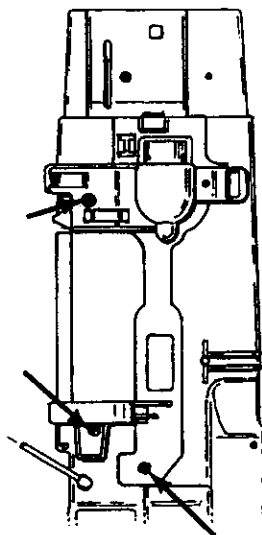

Fig. 14

1. Release two clips (Fig. 15)

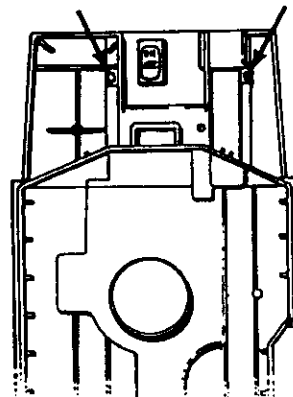

Fig. 15

2. Lift wand / hose holder out of position. Dirt Duct is trapped into position by wand / hose holder. On EDF models it is supplied with the microphone. Gasket is replaceable.

Note the routing of the wiring to the switch and microphone (where applicable) (Fig. 16).

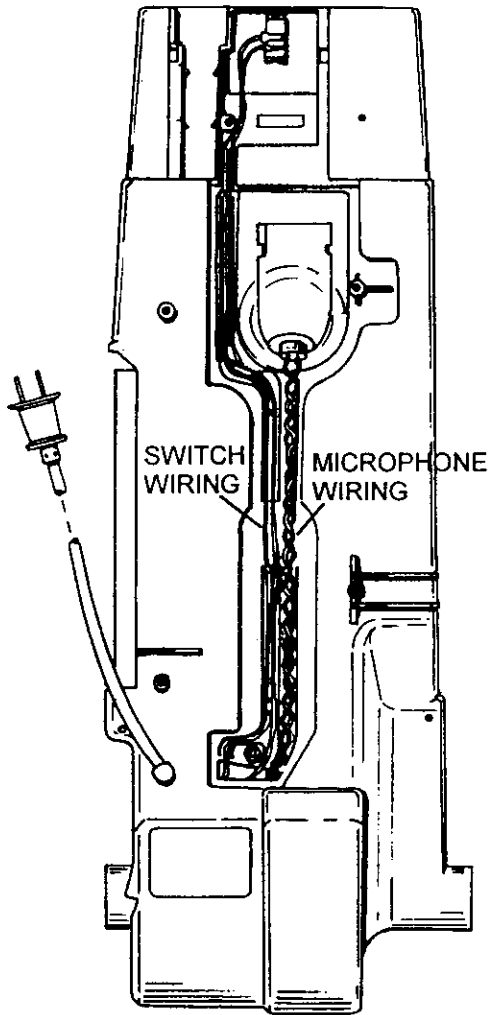

Fig. 16

### O. Switch

1. Switch is exposed once upper handle and wand / hose holder are removed. Disconnect leads and remove switch.

### P. Headlight Lens

1. Remove two screws and lift off lens (Fig. 17).

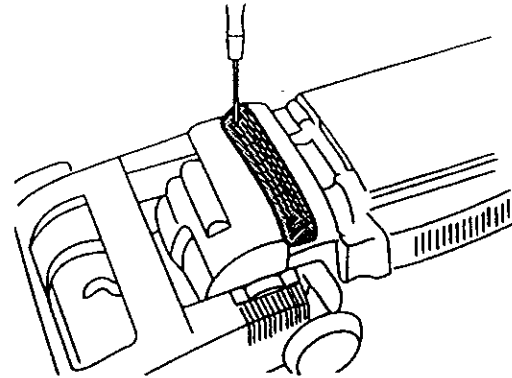

Fig. 17

### Q. EDF Printed Circuit Board Assembly (where applicable)

1. Remove headlight bracket screw.
2. Raise panel and board out of position
3. Unsnap four tabs to separate the board and cover.
4. Disconnect leads and replace board.

To ease reassembly of the board into the cover remove the red and green lens, snap board into position then reassemble both the lens.

Note: The discharge of static electricity to a circuit board can damage the components. When removing the circuit board from the following precautions should be taken.

1. Avoid being statically charged when handling board.
2. Circuit board should be handled by outside edge only.
3. **DON'T** touch the metal traces (circuits) on bottom of circuit board.

## R. Wire Opening Plug

This plug is in the bottom of the EDF cavity. It is important to keep this plug in position to eliminate air leakage (Fig. 18)

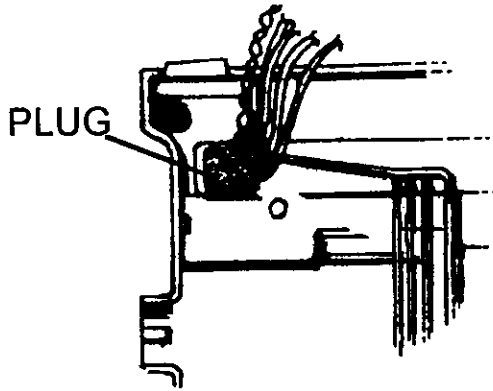

Fig. 18

## S. Motor Cover

1. Remove five screws and lift off (Fig. 19)

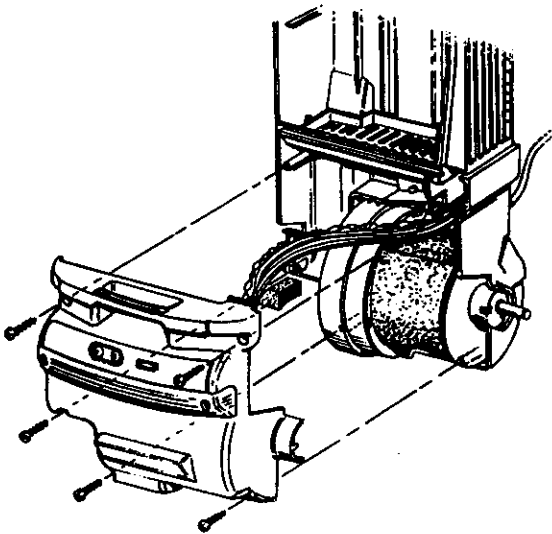

Fig. 19

## T. Cord

1. Remove strain relief.
2. Disconnect leads and replace cord.

## U. Motor

1. Remove bottomplate and agitator (Section A)
2. Remove hood (Section C)
3. Remove trunnion covers and hose clamp screws. (Section F)
4. Remove motor cover. (Section S)
5. Remove motor sound foam. (late models only)
6. Lift motor out of position and disconnect leads.

The motor is replaced as an assembly. Motor brushes are available.

## V. Motor Brushes

Brushes are supplied as an assembly which include the brush and brush holder.

### To Replace:

1. Pry open tab on brush holder and work out of holder.
2. Grasp brush holder with needle nose pliers and pull out of position.

### To install:

Position brush holder and slide into position insuring the terminal connection.

**Note:** Do not grasp outside of brush holder with pliers as it could damage the holder and cause the brush to stick.

### III. Troubleshooting check list - WindTunnel

The following is a guide to aid in determining the origin of a problem for which this model could conceivably be brought in for service.

<b>Problem</b>	<b>Possible Cause</b>	<b>Possible Solution</b>
A. Motor won't run	1. Open in attachment cord.	1. Replace cord.
	2. Open in wiring.	2. Check connections at motor and insulated terminals. Check wiring to switch.
	3. Thermal protector open.	3. Replace TOC (early models). Unplug unit and plug it back in and check operation (late models). Continual tripping of TOC requires further attention.
	4. Switch failed.	4. Replace switch.
	5. Switch rod failed.	5. Replace upper handle assembly.
	6. Motor brushes failed.	6. Replace motor brushes.
	7. Motor failed.	7. Replace motor assembly.
B. No pickup at nozzle	1. Agitator belt broken.	1. Replace belt.
	2. Agitator brushes worn.	2. Replace agitator.
	3. Paper bag full.	3. Replace bag.
	4. Secondary filter clogged.	4. Clean or replace filter.
	5. Gasket on bag door damaged.	5. Replace gasket.
	6. Gasket at base of bag door damaged.	6. Replace gasket.
	7. Seal on dirt duct damaged.	7. Replace seal.
	8. Hose disconnected at rear of unit.	8. Check to insure hose is locked into dirt duct and nozzle hose extension or angled hose connection.
	9. Hole in hose or hose clogged.	9. Replace hose or clear obstruction.
	10. Hose from nozzle damaged or mispositioned.	10. Replace if damaged. Check to insure hose is properly held in position by hose clamp at main body.
	11. Seals in agitator cavity or bottomplate worn or missing.	11. Replace. This condition will not result in significant suction loss.
	12. Motor mount mispositioned or damaged.	12. Replace or reposition. Position is critical.
C. No pickup using tools	1. Hose damaged or clogged.	1. Clear obstruction or replace hose.
	2. Hose not locked into dirt duct.	2. Check connection.
	3. Bag full.	3. Replace bag.
	4. Secondary filter clogged.	4. Clean or replace filter.
	5. Gasket on bag door damaged.	5. Replace gasket.
	6. Gasket at base of bag door damaged.	6. Replace gasket.
	7. Seal on dirt duct damaged.	7. Replace seal.
	8. Motor mount mispositioned or damaged.	8. Replace or reposition. Position is critical.

Problem	Possible Cause	Possible Solution
D. EDF circuitry not working Green light won't come on	Note: When the unit is energized there is a slight delay then the green light illuminates. If the green light does not come on check the following: 1. No power to board. 2. Circuit board failed.	1. Check 120 volt leads on the LH side of the board. Also check connection at wire nut and motor connector. 2. Replace board.
E. Light doesn't change from green to red during normal operation	Note: The red light may seldom come on during cleaning. This means your cleaner is picking up primarily fine surface dust and lint which the system may not detect or the carpet is clean. Switch the unit to Hi sensitivity and re-check. Also check the following: 1. Microphone out of position. 2. Dirt duct opening "caked" with dirt. 3. Microphone leads disconnected from board. (Small leads on RH side) 4. Microphone failed.	1. Check to insure the microphone is firmly pressed into the seat in the dirt duct. 2. Clean and check operation. 3. Check connection. 4. Replace- check the above first.
F. Red light stays on. Won't go to green	Note: Run cleaner while holding it off the floor. If green light does not come on check the following: 1. Circuit board failed.	1. Replace board.
G. Thermal protector trips	1. Final filter clogged. 2. Motor bearing tight- motor dragging. 3. Thermal Protector defective.	1. Clean or replace filter. 2. Replace motor. 3. Replace TOC and check operation. Check items 1 and 2 first.

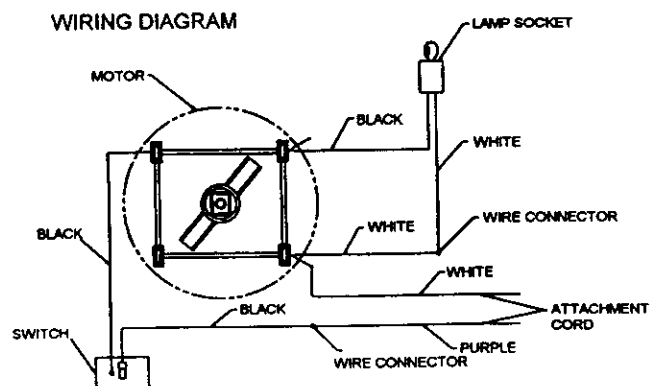
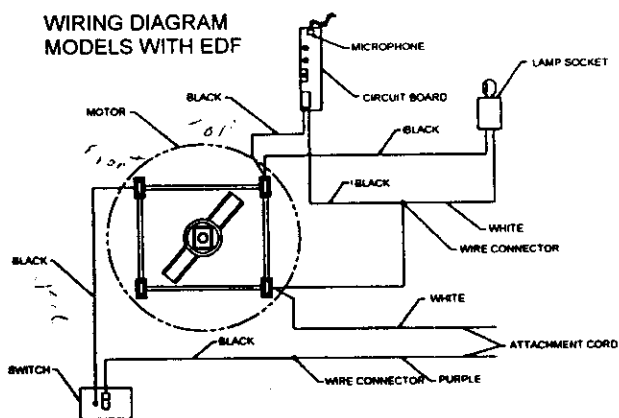

# Troubleshooting Guide

## WindTunnel Cleaners



The following is a guide to aid in determining the origin of a problem for which this model could conceivably be brought in for service.

<b>Problem</b>	<b>Possible Cause</b>	<b>Possible Solution</b>
<b>A. Motor won't run</b>	1. Open in attachment cord.	1. Replace cord.
	2. Open in wiring.	2. Check connections at motor and insulated terminals. Check wiring to switch.
	3. Thermal protector open.	3. Replace TOC (early models). Unplug unit and plug it back in and check operation (late models). Continual tripping of TOC requires further attention.
	4. Switch failed.	4. Replace switch.
	5. Switch rod failed.	5. Replace upper handle assembly.
	6. Motor brushes failed.	6. Replace motor brushes.
	7. Motor failed.	7. Replace motor assembly.
<b>B. No pickup at nozzle</b>	1. Agitator belt broken.	1. Replace belt.
	2. Agitator brushes worn.	2. Replace agitator.
	3. Paper bag full.	3. Replace bag.
	4. Secondary filter clogged.	4. Clean or replace filter.
	5. Gasket on bag door damaged.	5. Replace gasket.
	6. Gasket at base of bag door damaged.	6. Replace gasket.
	7. Seal on dirt duct damaged.	7. Replace seal.
	8. Hose disconnected at rear of unit.	8. Check to insure hose is locked into dirt duct and nozzle hose extension or angled hose connection.
	9. Hole in hose or hose clogged.	9. Replace hose or clear obstruction.
	10. Hose from nozzle damaged or mispositioned.	10. Replace if damaged. Check to insure hose is properly held in position by hose clamp at main body.
	11. Seals in agitator cavity or bottomplate worn or missing.	11. Replace. This condition will not result in significant suction loss.
	12. Motor mount mispositioned or damaged.	12. Replace or reposition. Position is critical.
<b>C. No pickup using tools</b>	1. Hose damaged or clogged.	1. Clear obstruction or replace hose.
	2. Hose not locked into dirt duct.	2. Check connection.
	3. Bag full.	3. Replace bag.
	4. Secondary filter clogged.	4. Clean or replace filter.
	5. Gasket on bag door damaged.	5. Replace gasket.
	6. Gasket at base of bag door damaged.	6. Replace gasket.
	7. Seal on dirt duct damaged.	7. Replace seal.
	8. Motor mount mispositioned or damaged.	8. Replace or reposition. Position is critical.

<b>Problem</b>	<b>Possible Cause</b>	<b>Possible Solution</b>
D. EDF circuitry not working Green light won't come on	Note: When the unit is energized there is a slight delay then the green light illuminates. If the green light does not come on check the following: 1. No power to board. 2. Circuit board failed.	1. Check 120 volt leads on the LH side of the board. Also check connection at wire nut and motor connector. 2. Replace board.
E. Light doesn't change from green to red during normal operation	Note: The red light may seldom come on during cleaning. This means your cleaner is picking up primarily fine surface dust and lint which the system may not detect or the carpet is clean. Switch the unit to Hi sensitivity and re-check. Also check the following: 1. Microphone out of position. 2. Dirt duct opening "caked" with dirt. 3. Microphone leads disconnected from board. (Small leads on RH side) 4. Microphone failed.	1. Check to insure the microphone is firmly pressed into the seat in the dirt duct. 2. Clean and check operation. 3. Check connection. 4. Replace- check the above first.
F. Red light stays on. Won't go to green	Note: Run cleaner while holding it off the floor. If green light does not come on check the following: 1. Circuit board failed.	1. Replace board.
G. Thermal protector trips	1. Final filter clogged. 2. Motor bearing tight- motor dragging. 3. Thermal Protector defective.	1. Clean or replace filter. 2. Replace motor. 3. Replace TOC and check operation. Check items 1 and 2 first.