

INALSA

OVEN TOASTER GRILLER

Master  Chef
Quick  Chef

Instruction Manual
Cum
Warranty Card

Dear Customer,

Congratulations! On the purchase of your INALSA Oven Toaster Griller, this is designed to include many superior features that permit you the fullest expression of your cooking skill and enthusiasm. You are now on the threshold of a whole new world of cooking pleasure.

At INALSA, we have a reputation of manufacturing innovative, high quality appliances such as Food Processors, Mixer Grinders, Juicer Mixer Grinders, Cooking Ranges, Juice Extractors, Cooktops, Oven Toaster Grillers, Hand Blenders, Electric Kettles, Rice Cookers, and Electric Chimneys. Your newly acquired INALSA Oven Toaster Griller bears the same distinctive hallmark of excellence.

It is all the result of vigorous quality consciousness in INALSA's design and development where uncompromising standards are maintained and rigid quality control measures are exercised on raw materials, components and finally, the finished product.

Your INALSA Oven Toaster Griller has a lot of thoughtful features built in to make your cooking convenient. Please read these instructions carefully, so that you may get the best out of the power packed features in your INALSA Oven Toaster Griller.

Welcome to the INALSA world of cooking pleasure!!

Parts Identification

Master Chef / Quick Chef (10BK)

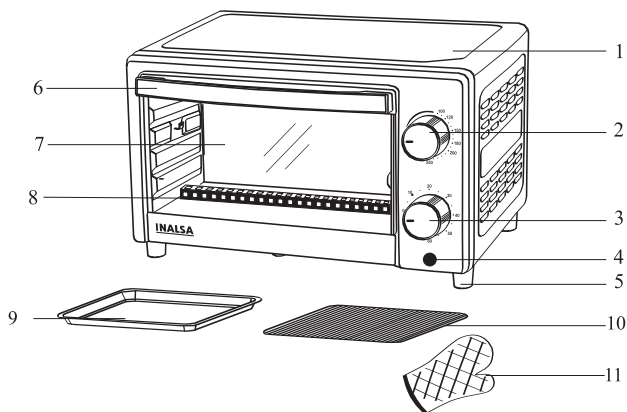

<u>Part No.</u>	<u>Parts Name</u>
1.	Top body frame
2.	Thermostat knob
3.	Timer knob
4.	Power indicator
5.	Legs
6.	Door handle
7.	Glass door
8.	Heating element
9.	Drip tray
10.	Wire rack
11.	Hand Glove

Parts Identification

Master Chef / Quick Chef (16BK)

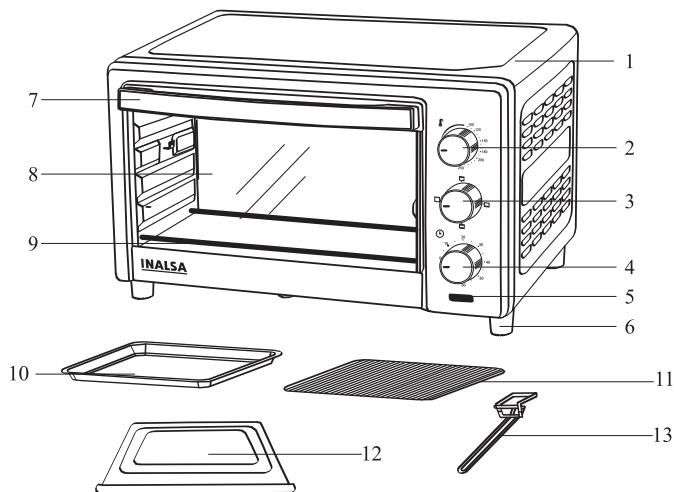

Part No.	Parts Name
1.	Top body frame
2.	Thermostat knob
3.	Heat selector knob
4.	Timer knob
5.	Power indicator
6.	Legs
7.	Door handle
8.	Glass door
9.	Heating element
10.	Drip tray
11.	Wire rack
12.	Crumb tray
13.	Tray handle

Parts Identification

Master Chef / Quick Chef (19BKR)

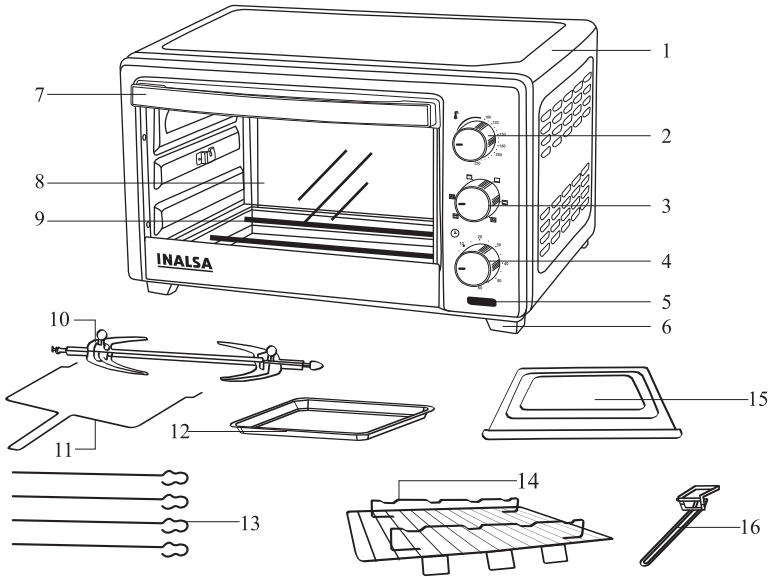

Part No.	Parts Name
1.	Rust proof housing
2.	Thermostat knob
3.	Heat selector knob
4.	Timer knob
5.	Power indicator
6.	Legs
7.	Door handle
8.	Glass door
9.	Heating element
10.	Rotisserie set
11.	Rotisserie handle
12.	Drip tray
13.	Skewer rod - 4 Nos.
14.	Wave wire grill rack
15.	Crumb tray
16.	Tray handle

Parts Identification

Master Chef (24RSS)

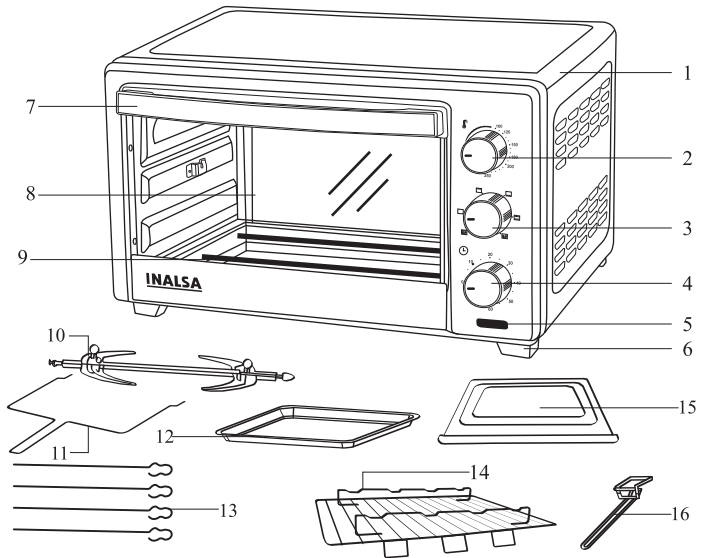

Part No.	Parts Name
1.	Rust proof housing
2.	Thermostat knob
3.	Heat selector knob
4.	Timer knob
5.	Power indicator
6.	Legs
7.	Door handle
8.	Glass door
9.	Heating element
10.	Rotisserie set
11.	Rotisserie handle
12.	Drip tray
13.	Skewer rod- 4 Nos.
14.	Wave wire grill rack
15.	Crumb tray
16.	Tray handle

Parts Identification

Master Chef (30SSRC/46SSRC)

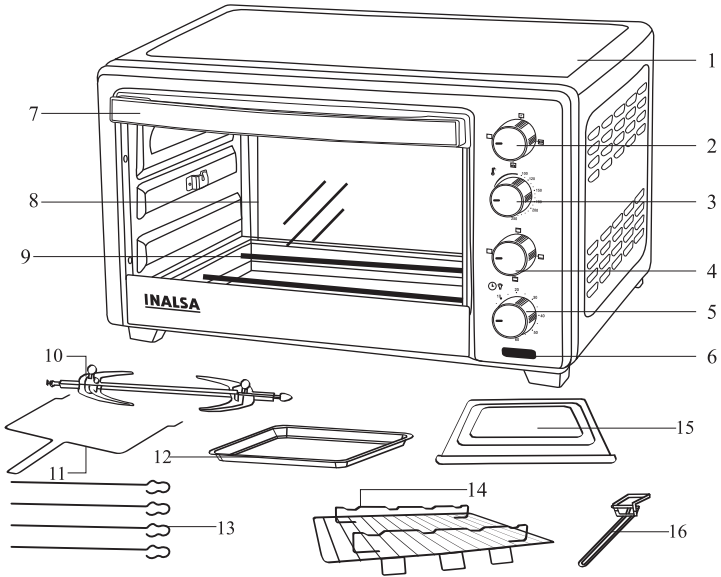

<u>Part No.</u>	<u>Parts Name</u>
1.	Rust proof housing
2.	Rotisserie / Convection selector knob
3.	Thermostat knob
4.	Heat selector knob
5.	Timer knob
6.	Power indicator
7.	Door handle
8.	Glass door
9.	Heating element
10.	Rotisserie set
11.	Rotisserie handle
12.	Drip tray
13.	Skewer rod - 4 Nos.
14.	Wave wire grill rack
15.	Crumb tray
16.	Tray handle

Technical Specifications *

Specification	Master Chef / Quick Chef			Master Chef		
	10BK	16BK	19BKR	24RSS	30SSRC	46SSRC
Capacity (L)	10	16	19	24	30	46
Voltage	220-240V, AC, 50/60Hz					
Power (W)	800	1300		1600		2000
Heating element	Quartz	Stainless Steel				
Timer	60 Mins. with STAY ON function					
Rotisserie	Not provided		Provided			
Skewer Rods	Not provided		Provided (4 Nos.)			
Convection	Not provided				Provided	
Thermostat	100 to 250°C					
Housing	Rust Proof Powder coated			Rust Proof Stainless Steel		
Bulb	No				Yes	

* Due to continuous improvements in product, specifications are subject to change without prior notice.

Important Instructions

Do's

1. Ensure that the appliance is placed on firm level surface and close to an electrical outlet.
2. A distance of at least 10cm should be maintained between the oven and the wall.
3. Before putting the food on the tray, spread a layer of edible oil onto the tray to avoid the food sticking to the tray after baking.
4. If the supply cord is damaged, it must be replaced by the authorized service personnel of the company in order to avoid a hazard.
5. Always keeps children away from the oven.

Don'ts

1. Never use the oven if it is damaged in any way.
2. When in use, the oven is hot! Never touch the oven and the glass door.
3. Don't let power cord hang over the edge of the table or kitchen worktop or touch hot surfaces.
4. Don't use out doors.
5. Don't sprinkle water on the glass window whilst it is still very hot, this could cause the glass to crack.
6. The user must not leave the oven during use.
7. Remove the plug from the power socket after use.
8. The oven can not be put into water or washed with water.
9. Do not place the appliance near a source of heat.

10. Never place any paper, cardboard or plastic in the oven and do not place anything on top of it (utensils, objects etc.)
11. Do not operate you appliance under a wall cupboard, shelves or close to flammable materials such as blinds, curtain, etc.

Before using for the first time

1. Carefully unpack the oven making sure to remove all packing materials.
2. Wipe the oven and accessories with a damp cloth, and dry.
3. Remove all the accessories from the oven (rack, tray etc.)
4. Fully unwind the removable cord plug.
5. Plug in and adjust the thermostat knob at maximum setting.
6. Set the timer knob to 15 minutes.
7. Run empty oven for 15 minutes, smoke etc.

Caution: During heating smoke may appear. This is normal and will soon disappear.

How to use

Function Knob (Master Chef 30SSRC/46SSRC)

1. OFF
2. Convection
3. Rotisserie.
4. Convection & Rotisserie.

Heat Selector Knob (Master Chef 16BK / 30SSRC / 46SSRC / Quick Chef 16BK)

1. OFF
2. Top heating element.
3. Bottom heating element.
4. Top & bottom heating element.

Heat Selector Knob (Master Chef 19BKR / 24RSS / Quick Chef 19BKR)

1. Top heating element.
2. Bottom heating element.
3. Top & bottom heating element.
4. Top heating element & rotisserie.
5. Bottom heating & rotisserie.
6. Top & bottom heating element with rotisserie.

Before use

1. Ensure that there is enough ventilation around the oven.
2. Ensure that the oven is completely dry before use.

3. The oven should not be placed on untreated wooden surface. Place the oven on a heat resistant surface.
4. The feet of the oven can leave some marks on the table, if this happens, remove the marks with a damp cloth.

Oven use

1. Turn the thermostat dial clockwise to the desired temperature.
2. Turn the selector dial to the desired position.
3. Turn the timer dial clockwise to the desired cooking time.
STAY ON Timer : Turn timer dial anti-clockwise to “STAY ON” position for continuous use. Oven will keep working until it is turned OFF manually
4. The power light will light up after timer is turned on, and will go out when the timer is turned to OFF.
5. When the cooking time is over, the timer will auto shut off and the bell will ring.
6. If the cooking is finished earlier than the set cooking time, please turn back the timer to OFF to turn off the oven.
7. In the first use of this oven, there might be some light smoke coming out from the oven, this is normal. After 5-15 minutes the smoke will disappear.
8. In order to get better cooking performance, it is recommended to pre-heat the oven about 10-15 minutes.

Rotisserie use

1. Put one skewer through the pointed end of the spit, making sure the points of skewer face towards the spit's pointed end. Slide the skewer towards the square end of the spit.
2. Insert the spit directly through the center of the food which you want to roast.
3. Put the other skewer through the pointed end of the spit, making sure the points of skewer face the spit's square end.
4. Put the two skewers into the food, then secure both skewers with the thumbscrews.
5. Make sure the food is centered on the spit.
6. Insert the pointed end of the spit into the drive socket, make sure the square end of the spit rests on the spit support.
7. Plug the oven.
8. Set the thermostat to 250°C.
9. Turn the timer to the time which you require, the power indicator will light up. Normally it takes 30 minutes to roast a 2.5Kg(5.5Pd) weight chicken.
10. Set the selector to ROTISSERIE or Full Function setting, the rotisserie starts rotating.
11. When roasting is completed, turn back the timer to OFF.
12. After the oven is cooled, place the hooks of the rotisserie handle under the grooves on both sides of the spit. Lift the right side of the spit first, move towards right side a little bit, so that the left side of the spit goes out of the drive socket. Then carefully move out the roasted food from the oven.
13. Take the food off the spit.

Grill cooking

1. Leave the door at the open point.
2. Turn the selector to GRILL setting (Top heating).
3. Turn the temperature dial to 250°C.
4. Turn the timer to the desired grill time.
5. When the grill cooking is done, turn back the timer to OFF to turn off the oven.

Practical advice

1. When baking or grilling, it is advisable to always pre-heat the oven to the desired temperature, to get the best possible cooking results.
2. Cooking time depends on the ingredient quality, the food temperature and on individual taste. The time suggested in this manual are only indicative and thus susceptible to variations and do not take into account the time needed to pre-heat the oven.
3. When cooking freeze-dried foods, check the time suggested in the products' packaging.
4. Do not leave the food in the oven for a long time as it may become too dry.

Convection cooking (Available in Master Chef 30SSRC/46SSRC only)

1. This function is ideal for cooking great savory pies, all types of meat-based main dishes (apart from small fowl), roast potatoes and cakes in general. It is also suitable for simultaneous cooking on two different levels.
2. Insert the wire rack to the oven.
3. Turn the function selector knob to convection position.
4. Set the thermostat at required temperature.
5. Set the timer knob to the desired time setting.
6. Wait for the oven to reach the set temperature (the pilot light goes off), then put the food in.
7. If cooking is completed before the set time manually turn the timer knob to position "O".

Cleaning and maintenance

1. Allow appliance to cool completely before cleaning. Unplug cord from the outlet.
2. The grill & drip tray may be washed as other kitchen ware, either by hand or in the dishwasher
3. To clean the outside surfaces always use a moist sponge. Avoid using abrasive products that could damage the finish. Ensure water or soap does not penetrate the inside of the oven through the vents.
4. Never immerse the appliance in water.
5. To clean the inside walls never use aluminum-corrosive products (spray detergents) and never scrape the walls with sharp or pointed objects.

INALSA

**OVEN TOASTER
GRILLER**

*Recipes
Book*

Recipes for Inalsa OTG

Vegetarian

Chilly Garlic Lady finger

Ingredients

Lady finger	:	500 gm.
Oil	:	4 tsp
Green chillies, finely chopped	:	5-6 pieces
Garlic, finely chopped	:	10-12 flakes
Lime juice	:	1 tsp
Slat	:	1 tsp

Method of Preparation

1. Clean the lady fingers and slit them from the centre keeping the ends intact.
2. Spread half of the oil on the drip/baking tray and keep aside.
3. Mix together the green chillies and garlic along with lime juice and salt.
4. Stuff the lady finger with the green chilly garlic masala.
5. Place the stuffed lady fingers on the greased drip/ baking tray. Brush the lady fingers with the balance oil.
6. Grill and 250 degree C.
7. Serve hot with paranthas or chapattis.

Quick Pizza

Ingredients

Pizza bread	:	1 small
Cooked corn	:	2 tbsp
Tomato sauce/Puree	:	2 tbsp
Onion rings	:	3-4
Oregano/Ajwain	:	¼ tsp
Pepper	:	¼ tsp
Cheese cubes, grated	:	2 cubes

A little butter

Method of Preparation

1. Spread sauce on the pizza bread.
2. Sprinkle ajwain and then spread the corn and a sprinkle of pepper.
3. Arrange onion and capsicum rings. Top with cheese.
4. Grill for five minutes.

Stuffed Pepper Platter

Ingredients

Peppers (red, green and yellow)	:	6
Leftover rice/ spicy vegetable	:	50 gm
Garlic, chopped	:	1 tbsp
Cheese, grated	:	30 gm
Slat to taste		

Method of Preparation

1. Spilt open the peppers into halves. Blanch in hot water for 10 seconds.
2. Rub the inside of the pepper with salt and garlic.
3. Add the filling of our choice leftover rice, curry or palak paneer.
4. Top with cheese and bake till cheese melts.
5. Serve as an accompaniment or on its own.

Baked Tomatoes

Ingredients

Tomatoes, hard & ripe	:	6 medium sized, halved
Cheese spread	:	½ cup
Fresh cream, well beaten	:	½ cup
Coriander leaves	:	A few, finely chopped
Green chillies, finely chopped	:	2
Spring onion, finely chopped	:	2
Cinnamon ground	:	½ tsp
Salt	:	To taste

Method of Preparation

1. Mix all the ingredients except the tomatoes and cinnamon powder.
2. Fill each tomato half with this mixture, pushing it inside the tomato with spoon.
3. Arrange all the tomatoes in a baking tray.
4. Sprinkle cinnamon powder.
5. Bake in a pre-heated oven for about 10-12 minutes at 220° C.

Pasta Bake

Ingredients

Macaroni	:	200gm.
Onions	:	2 large
Ginger Garlic paste	:	2 tbsps

Tomato puree	:	½ cup
Mushrooms	:	1 cup
Butter	:	5 tbsps
Flour	:	2 tbsps
Milk	:	1½ cup
Salt, red chilly, pepper powder	:	To taste

Method of Preparation

1. Boil the macaroni in salted water till tender, drain and keep aside.
2. Chop and saute one onion in butter till transparent, then add ginger and garlic paste and fry till oil comes to the top.
3. Add tomato puree, boiled macaroni, salt pepper and red chilly to taste. Fry till mixture is dry.
4. Clean and chop the mushrooms. Chop and saute the remaining onion in butter.
5. When transparent, add mushrooms, salt, red chilly and pepper. Add water and cook till done.
6. Melt 2 tbsps butter and add sifted flour. Cook till flour turns pink, then remove from fire and slowly add milk stirring all the time.
7. Bring to a boil when all the milk is used up.
8. Line a buttered baking dish with cooked mushrooms and pour half the white sauce.
9. Next spread the macaroni mixture and pour the remaining white sauce.
10. Bake at 200-220° C till firmly set.

Tomato Souffle

Ingredients

Tomatoes boiled and pureed	:	300gm.
Paneer, grated	:	50 gm.
Onion, chopped	:	20 gm.
Butter	:	10 gm.
Bread	:	1 slice
Milk	:	3 tbsps
Chilly powder	:	½ tsp
Salt	:	To taste

Bread crumbs as required

Method of Preparation

1. Mix all the ingredients and keep aside for fine minutes.
2. Divide the mixture into six balls and neatly pierce it through skewer and bake in tandoor/ oven till light golden in colour. Remove from skewer.
3. Serve on a plate, sprinkle lemon juice and chat masala. Place onion rings on the side.

Cheese and Peas Bake

Ingredients

Tomato shells	:	4
Boiled peas	:	1 cup
Chopped onion	:	2 small
Pulp of 4 tomatoes		
Cheese, grated	:	2 tbsp
Breadcrumbs	:	1 tbsp
Salt and pepper	:	To taste
White sauce	:	1 cup
For White Sauce		
Butter	:	1 tbsp
Maida	:	2 tbsp
Milk	:	200 ml
Salt and pepper	:	To taste

Method of Preparation

1. Prepare white sauce by gently roasting the maida in the butter. As soon as there is an aroma, remove from fire and beat in milk, stirring constantly to break lumps.
2. Place on low flame and heat gently till it begins to bubble. Remove and season. Let it cool.
3. Fry onions till golden brown. add peas and a little water.
4. Cover and cook till peas are tender.
5. Add tomato pulp and cook till dry. Mix with white sauce.
6. Add cheese, keeping half aside. Adjust seasoning.
7. Mix the rest of the cheese with the Breadcrumbs. Spoon filling into the shells.
8. Top with the bread crumbs cheese and bake till it turns golden brown. Serve hot.

Mixed Vegetable Fiesta

Ingredients

For the pastry	:	100 gm.
Flour	:	500 gm.
Butter	:	1 tsp
Salt	:	To taste
For the filling		
Paneer, cubed	:	100 gm.
Mixed vegetables, chopped	:	1½ cups

Onion	:	1 large
Eggs	:	2
Cheese	:	50 gm.
Butter	:	2 tbsps
Milk	:	2 tbsps
Salt, pepper, red chilly powder	:	To taste

Method of Preparation

1. Rub the butter and salt into sifted flour till texture resembles breadcrumb
2. Add the required cold water and form into a dough.
3. Roll the dough evenly and line a buttered pie dish. Keeps in fridge till required.
4. Chop the onion and saute in butter till transparent.

Rich Bread Vegetable

Ingredients

Mixed vegetables	:	250 gm.
Onion	:	1 large
Ginger & garlic paste	:	2 tbsps
Milk extract from 1 coconut	:	
Tomato puree	:	1 cup
Bread slices	:	6
Cheese	:	100gm.
Arrowroot powder	:	2 tbsps
Cashewnuts	:	30 gm.
Raisins	:	30 gm.
Coriander	:	2 springs
Butter	:	4 tbsps
Milk	:	1 cup
Slat, red chilly, garam masala and chat masala to taste		

Method of Preparation

1. Chop one onion and saute in butter till transparent.
2. Add ginger and garlic paste and fry till oil oozes on the top.
3. Ad mixed chopped vegetables, coconut extract, chopped coriander, broken cashew nuts and raisins. Add salt, red chilly, chat masala and pepper.
4. Cook till vegetables are done. Add milk if necessary.
5. Bring tomato puree to a boil. Add salt, red chilly and arrowroot powder (mixed in cold water).

6. Keep stirring till mixture become thick. Cool.
7. Dip bread slices in salted milk and line a buttered ovenproof dish with the slices.
8. Spread the cooked vegetables on the bread slices and pour the tomato puree.
9. Sprinkle grated cheese and dot with butter.
10. Bake at 180°C for 20 minutes, till firm. Serve hot.

Vegetarian Kababs

Ingredients

Potatoes	:	400 gm.
Carrots	:	100 gm.
French beans	:	100 gm.
Peas	:	100 gm.
Soya granules	:	300 gm.
Coriander leaves	:	½ bunch
Oil	:	1½ tsp
Salt	:	To taste
Green chilly paste	:	2 tbsp
Dhania jeera powder	:	1 tbsp

Method of Preparation

1. Steam vegetable and soya granules in pressure cooker.
2. Mix and mash all the steamed ingredients and add salt, dhania-jeera powder, green chilly paste and coriander leaves.
3. Knead well and make into 3" long rolls.
4. Dip a finger in the oil and apply on the kababs and grill in a oven till brown.
5. Serve hot with a dip.

Tomato and Veg Lasagne

Ingredients

Lasagne sheets	:	80 gm.
Tomato (chopped)	:	10 gm.
Cheese (grated)	:	60 gm.
Mixed vegetable (diced & boiled)	:	60 gm.
Bechamel sauce	:	60 gm.

For Bechamel Sauce

Butter	:	1 tbsp
Plain flour	:	1 tbsp
Hot milk	:	1 cup

Salt	:	To taste
Freshly ground pepper		
Grated nutmeg		
For Tomato Sauce		
Olive oil	:	¼ cup
Garlic	:	3 cloves
Bay leaves	:	2
Tomatoes (blanched & chopped)	:	400 gm.

Salt

Black pepper

Method of Preparation

1. To prepare bechamel sauce, heat butter in a pan and when it starts to foam, stir in the flour. Stir constantly until the mixture is golden.
2. Slowly pour in hot (not boiling) milk a little at a time, constantly stirring till the sauce is smooth and thick. Season with salt and pepper and a little grated nutmeg. Keep aside.
3. Boil lasagne in plenty of water that is at a rolling boil. Add the sheets one by one adding one tbsp of oil to prevent the sheets from sticking.
4. Cook till just tender and remove carefully with two spatulas and lay them to cool on a clean towel, wring out in cold water.
5. To make tomato sauce, heat the oil in a frying pan and brown garlic and bay leaves.
6. Add tomatoes and a little water. Add seasoning and bring to boil. Simmer for 12-14 minutes. Strain.
7. Take a deep pie dish and make layers with lasagne, tomatoes, cheese and vegetable with bechamel sauce and cheese. Bake in a moderate oven and serve on a bed of tomato sauce.

Saffron & Spinach Casserole

Ingredients

Pasta/Macaroni	:	1 cup
Oil	:	1 tbsp
Onion	:	1 large
Garlic	:	15 cloves
French beans	:	8-10
Zucchini	:	1 medium
Broccoli	:	½ medium
Spinach	:	½ bunch
Carrots	:	2 medium
Butter	:	3 tbsp

Maida	:	1 tbsp
Milk	:	1½ cups
Nutmeg (Grated)	:	1 pinch
Cheese (Grated)	:	1 cup
Salt	:	To taste
Pepper powder	:	¼
Peppercorns (freshly crushed)	:	¼ tsp
Saffron	:	A generous pinch

Method of Preparation

1. Heat water, bring it to boil. Add 1 tablespoon of oil and the pasta. Boil till it is nearly done, but not fully.
2. Peel, wash and chop onions. Peel and finely chop garlic.
3. Boil water and blanch French beans, zucchini, broccoli, spinach and carrot one by one. Cut beans, zucchini and carrots in diamond shape. Puree the blanched spinach and break broccoli into small florets.
4. Heat 1 tbsp of butter and lightly saute maida. Gradually add 1 cup milk and stir continuously so that no lumps remain. Add nutmeg, some cheese, salt and pepper powder. This is the mornay sauce.
5. Heat 1 tbsp of butter in a pan, add chopped garlic, saute till golden brown, Add chopped onion and saute again till golden brown.
6. Add beans, broccoli, zucchini and salt and saute well.
7. Add half of the mornay sauce. ½ cup of milk and mix well.
8. Add spinach puree and half of the freshly crushed pepper and mix well.
9. Dissolve the saffron in remaining ½ cup of milk.
10. In another pan, heat the remaining butter and saute carrots. Add boiled pasta, remaining mornay sauce, saffron milk and mix well. Add salt. Cook for some time and add the remaining freshly crushed pepper.
11. In an oven proof dish, pour the green vegetable mixture and then pour the carrots-pasta mixture over it. Again spread a layer of remaining grated cheese and bake of for 5-10 minutes in a preheated oven at 250°C till the cheese melts and turns golden.

Non-Vegetarian

Protein Packs

Ingredients

Tomato shells	:	4
Eggs	:	2
Butter	:	2 tbsps
Chicken shreds (boiled)	:	½ cup
Salt, pepper, mustard powder	:	To taste

Method of Preparation

1. Beat the eggs.
2. Heat butter and cook the eggs over a gentle flame, stirring constantly.
3. When nearly cooked, add seasoning and chicken.
4. Spoon into shells and grill.

Fish Kababs

Ingredients

Onion	:	1 small
Ginger	:	1 inch piece
Garlic	:	6-7 flakes
Green chillies	:	5
Lime juice	:	1 tsp
Oil	:	8 tsp
Potatoes, boiled peeled & mashed	:	2 medium sized
Pomfret, boiled & mashed	:	1 (approx, 500 gms)
Garam masala	:	½ tsp
Salt	:	½ tsp

Method of Preparation

1. Grease drip / baking tray with 2 tsp of oil. Place washed and cleaned pomfret on it and bake at 250° C for 12 minutes.
2. Remove debone, clean tray and grease and keep aside.
3. Grind onions, ginger and green chillies along with lime juice to a fine paste.
4. Heat 3 tsp of oil. Add the ground paste. Fry for about 1 minute and mix the potatoes, fish, garam masala and salt. Mix well. Fry for about two minutes.
5. Cool and knead well.
6. Divide mixture into equal portions. Make balls and flatten them slightly. Place half the kababs in the drip/ baking tray. Baste with oil
7. Grill at 250° C. Turn the kabab midway during the cooking process.
8. Similarly grill the remaining kababs, basting with oil.
9. Serve hot along with rice. It can also be served as a snack.

Quick White Pie

Ingredients

Potatoes	:	250 gm.
Hard oiled eggs	:	4
Egg, stiffly beaten	:	1

Cheese	:	150 gm.
Groundnuts, ground	:	50 gm.
Breadcrumb	:	100gms
Salt, red chilly, chat masala, garam masala	:	To taste

Method of Preparation

1. Boil, peel and mash the potatoes, Add salt, red chilly powder, chat masala, garam masala to taste.
2. Chop the hard-boiled eggs and line a buttered Pyrex dish with it. Sprinkle the coarsely ground groundnuts.
3. Next, make a layer with the potato mixture.
4. Lastly, grate cheese and sprinkle on top.
5. Beat the egg stiffly and pour on top. Sprinkle breadcrumb
6. Dot with butter and bake for 20 minutes. Serve hot.

Kheema Cups

Ingredients

Tomato shells	:	4
Kheena	:	1½ cup
Onion, finely sliced	:	2 small
Pulp of 3 tomatoes	:	
Cloves	:	2
Cardamom seeds	:	2 large
Cinnamon	:	1 small piece
Tej patta	:	½
Haldi powder	:	½ tsp
Dhani-jeera powder	:	2 tsps
Salt	:	To taste
Oil	:	

Method of Preparation

1. Heat a little oil and fry onions till golden brown. Add all the whole spices.
2. Add kheema and fry till it turns dry and crumbly and dark brown in colour.
3. Add tomato pulp haldi dhania-jeera powder and salt to taste. Cover and cook till done. Continue cooking till kheema is absolutely dry. Let it cool.
4. Spoon into prepared shells and grill for 20 minutes till tomato looks tender.
5. Serve with large chunks of boiled eggs.

Mince Meat

Ingredients

Precooked kheema	:	¼ Kg.
Bread	:	6-8 slices
Curd	:	200 gm.
Fresh boiled peas	:	½ cup
Tomato, sliced	:	2
Grated cheese	:	1 cube
Salt & cummin	:	100 gm.

A few coriander leaves

Method of Preparation

1. Layer a baking dish with bread slices
2. Add salt, cumin powder and coriander leaves to the curd and then pour over the slices.
3. Layer it with kheema and then with peas and tomato slices.
4. Top with grated cheese and bake for 10 minutes. Serve hot.

Spaghetti with Chicken & Eggplant

Ingredients

Chicken (boneless)	:	200 gm.
Capsicum	:	2
Mustard paste	:	1 tbsp
Spaghetti	:	100 gm.
Eggplant (small)	:	4-5
Oil	:	6 tbsp
Tomato concasse	:	¾ cup
Garlic	:	3-4 cloves
Tomato ketchup	:	¼ cup
Peppercorns (crushed)	:	½ tsp
Parsley (finely chopped)	:	1 tsp
Red chillies (crushed)	:	3 tsp
Slat	:	To taste
Butter	:	1 tsp
Cheese (grated)	:	¾ cup

Method of Preparation

1. Wash remove stem, halve, deseed and cut capsicum into juliennes. Peel and chop garlic.
2. Clean and wash the chicken. Pat dry and cut into thin 1½ inches long strip. Marinate the chicken with mustard paste for about 15-20 minutes. Heat 2 tbsps oil in a frying pan and fry the chicken. Add capsicum juliennes and mix. Keep it aside.
3. Cut the eggplant into thin roundels and soak in cold salted water for 10 minutes.
4. Boil spaghetti in a large vessel in plenty of salted water with 1 tbsp of oil till it is nearly cooked. Drain, mix it with 1 tbsp of oil and spread on a plate to cool.
5. At the same time, heat 1 tbsp of oil in another frying pan, add garlic and saute, add tomato concasse, tomato ketchup and mix. Add salt, one third of the crushed black peppercorns and 1 tbsp of chopped fine parsley.
6. Add cooked spaghetti in the sauce and mix properly but gently. Remove from the heat and keep aside.
7. Heat the remaining oil in another frying pan and add roundels of eggplant. Let it cook on low heat. Add some salt, one third of the crushed peppercorns, half of the crushed red chilly, half tbsp of chopped parsley and mix. Turn over the eggplant roundels and again season it with salt, remaining crushed red chilly and half tbsp of chopped parsley.
8. Take a baking dish; apply butter on the base and inner sides. Cover the base with the cooked chicken and capsicum and then spread the spaghetti over.
9. Arrange the eggplant over the spaghetti until the spaghetti is covered entirely.
10. Sprinkle grated cheese and the remaining chopped parsley over it.
11. Cook in a preheated oven at 160 degree C for 10-15 minutes. Serve hot.

TIP: To make tomato concasse, blanch the tomatoes, remove the skin and the seeds and roughly chop.

Lamb Boulangere

Ingredients

Mutton leg	:	1 kg.
Garlic	:	8 cloves
Potatoes	:	4 medium
Onion	:	3 medium
Thyme	:	1 spring
Butter	:	2 tbsps
Salt	:	To taste
Pepper powder	:	¼ tsp
Bay leaf	:	1
Vegetable or chicken stock	:	1½ cups
Olive oil for greasing	:	As required
Parsley leaves	:	A few

Method of Preparation

1. Peel and slice half the garlic cloves. Crush the remaining half. Peel, wash and slice the potatoes and onion. Wash the thyme spring.
2. Make small incision in the mutton and insert thinly sliced pieces of garlic cloves into the incision.
3. Pre-heat the oven and grease in a baking dish with 1 tbsp butter.
4. Arrange the potatoes, onion, crushed garlic, herbs, salt and pepper in the buttered dish.
5. Add enough stock to just cover, dot with remaining butter, cover with foil and bake in the oven at 200° C for 30 minutes.
6. Grease a heavy frying pan with a little oil, add the mutton and sear quickly until brown all over.
7. Put the lamb on top of the potatoes and cover with a foil and bake for 1 hour at 200° C.
8. Remove the foil and bake it open for 10 minutes so that the top browns well. Remove mutton, slice, garnish with parsley leaves and serve hot with the potatoes.

Ground Meat Casserole

Ingredients

Mutton mince	:	500 gm
Garlic	:	2 cloves
Peppercorns	:	6
Clove	:	1
Thyme (dried)	:	1/8 tsp
Salt	:	To taste
Onion	:	½ small
Oil	:	2 tbsps
Green chillies	:	3
Green tomatoes	:	6 medium
Coriander leaves	:	½ cup
Capsicum	:	1
Capsicum	:	1
Oil	:	For frying
Corn tortilla	:	6
Sour cream	:	½ cup
Cheddar cheese (grated)	:	¾ cup

Method of Preparation

1. Grind 1 garlic clove, thyme and salt in a mortar.
2. Add to it the mutton mince and mix well
3. Peel, wash and chop onion.
4. Heat 1 tbsp oil in a pan add chopped onion and saute till it turns transparent. Add mutton mince and continue to saute over medium heat for 10 more minutes. Keep aside.
5. Boil 3 green chillies in half a cup of water for 2-3 minutes. Add the green tomatoes and cook until they change colour. Drain and let it cook for a while. Transfer to blender, add 1 clove of garlic, coriander leaves and salt, puree and keep aside.
6. Roast the capsicum till the outer skin is lightly charred. Remove the skin and cut into strips.
7. Preheat the oven to 190° C.
8. Heat the remaining oil in a skillet and fry each tortilla on both sides for minute each. Arrange 3 tortilla overlapping each other in a baking dish. Cover with a layer of mince, a layer of half the capsicum strips, a layer of half the sour cream and one third of the grated cheese. Repeat these layers once more. Cover with tomato puree made earlier and bake in the preheated oven for 10 minutes. Sprinkle the remaining grated cheese and bake till the cheese melts and browns.

Desserts/Puddings

Banana Walnut Cake

Ingredients

Bananas	:	4 large
Walnuts	:	5-6
Butter or Margarine	:	10 tbsps
Sugar	:	¾ cup
Eggs	:	3
Refined flour (maida)	:	2 cups
Baking powder	:	1 tsp
Baking soda	:	¼ tsp
Coffee powder	:	1 tsp
Vanilla essence	:	1 tsp
Cinnamon powder	:	1 tsp
Lemon juice (freshly squeezed)	:	1 tbsp
Milk	:	10 tbsps

Method of Preparation

1. Shell walnuts and coarsely chop them.
2. Cream butter and sugar till light and fluffy.
3. In a separate bowl. Break the eggs on at a time and beat them well.
4. Add the beaten eggs to the butter and sugar mixture and mix well.
5. Sieve flour with baking powder and baking soda.
6. Mix walnuts, vanilla essence, coffee powder and cinnamon in a bowl.
7. Mash the bananas, Add lemon juice. Mix it in the nuts mixture.
8. Add the flour mixture alternating with the banana mixture to the butter, sugar and egg mixture. Add milk. Mix lightly.
9. Pour the batter in a buttered, baking dish. Bake in preheated oven at 175° C for about 1 hour.
10. Let it cool in the dish initially and then gently unmould it onto a rack and leave it to cool.
11. Cut into slices and serve with tea.

Chocolate Brown

Ingredients

Chocolate chips/Crunchies	:	2 cups
All purpose flour	:	½ cup
Baking powder	:	¼ tsp
Slat	:	¼ tsp
Brown sugar	:	1½ cups
Butter	:	10 tbsps
Vanilla essence	:	½ tsp
Eggs	:	3

Method of Preparation

1. Mix together flour, baking power and salt in a bowl.
2. In a separate bowl, mix brown sugar, butter and vanilla essence together until creamy.
3. Beat eggs separately till light and fluffy. Add it to the brown sugar mixture and mix lightly.
4. Gradually mix the brown sugar and egg mixture into the flour mixture.
5. Add chocolate wafers/crunchies.
6. Spread the mixture on a greased flat tray.
7. Preheat the oven at 160° C.
8. Bake for 20-25 minutes or till the cake is done.
9. Take the tray out and let it cool completely.
10. Cut into desired shape and serve.

Boondi and Bread Pudding

Ingredients

Boondi laddoos	:	4
Bread	:	6 slices
Pure Ghee	:	2 tbsp
Almond	:	10
Pistachio nuts	:	10
Cashewnuts	:	10
Rabri	:	1½ cups
Sliver varq	:	1
Rose water	:	1 tsp

Method of Preparation

1. Blanch and slice almonds and pistachios. Take ghee in a pan and fry cashew nuts till golden brown. Reserve the ghee. Break the boondi laddoo to separate into individual boondi.
2. Trim the edges of the bread and cut into triangles.
3. Heat a little ghee on a tawa and toast the bread triangles slightly.
4. Spread half the slices in a baking dish.
5. Spread half the boondi over the slices evenly.
6. Pour half the rabri over the boondi.
7. Spread the remaining toasted slices followed by the remaining boondi and rabri.
8. Spread the fried cashew nuts, almonds and pistachio on the top.
9. Bake in a preheated oven at 220° C for 10 minutes.
10. When done, sprinkle some rose water and spread silver varq and serve hot.

TIP: You can also use condensed milk, slightly thinned with a little plain milk, instead of rabri.

Baked Apple Tart

Ingredients

For Sweet Paste

Butter	:	200 gm
Flour	:	400 gm
Icing sugar	:	200 gm
Eggs	:	5

For Apple Tart

Sweet paste for pie base

Fresh cream	:	400 ml
Eggs	:	5
Sugar	:	120 gm

- Cooking apples : 4
 Vanilla essence : A few drops

Method of Preparation

Basic sweet paste

1. Cream butter and sugar together till light.
2. Add eggs one by one beating constantly.
3. Fold in the flour.
4. Wrap dough in butter paper and chill for an hour.
5. Roll the paste to desired thickness.

For the tart

1. Press the sweet into tart mould and prick with a fork.
2. Half bake and keep aside.
3. Mix fresh cream with sugar, eggs and vanilla essence.
4. Peel and core apples and cut into 4. Place apple chunks in flan and pour the prepared mixtures over it Bake at 150° C for 30 minutes.
5. Cool and serve with fresh piped cream.

Basic Sponge Cake

Ingredients

- Eggs : 10
 Sugar : 250 gm.
 Flour : 250 gm.
 Flour : A few drops
 Vanilla essence

Method of Preparation

1. Beat eggs and sugar in a mixing bowl using a whisk till light and frothy. Add vanilla essence.
2. Fold in the flour.
3. Pour batter into 4 9” round tins bake at 160° C for 30-35 minutes.
4. Remove from tin and cool on a wire rack.

For Chocolate Sponge

1. Substitute vanilla essence with 50 gms cocoa powder.
2. Sieve cocoa with 200 gms of flour.
3. The method is same as above.

Cornflake Crunch

Ingredients

- Maida : 1½ cups

Soda bicarb	:	½ tsp
Baking powder	:	½ tsp
Butter	:	½ cup
Powdered sugar	:	½ cup
Egg	:	1
Nuts	:	½ cup
For smearing		
Cornflakes (crushed)	:	½ cup
Sugar	:	3 tbsp

Method of Preparation

1. Sieve maida soda and baking power.
2. In a bowl, beat the egg, add sugar and beat till well blended. Add butter and continue beating.
3. Slowly mix in the maida and lastly the nuts. Knead lightly. Form into lemon sized balls.
4. Roll in the cornflake-sugar mixture and flatten slightly.
5. Bake in a moderate oven for about 20 minutes.

Kesar Badam Biscuits

Ingredients

Maida	:	1½ cups
Baking powder	:	½ tsp
Sugar	:	½ cup
Cream/Malai	:	½ cup
Almond (powdered coarsely)	:	½ cup
Almond (whole)	:	A few
Saffron threads	:	A big pinch

Method of Preparation

1. Sieve maida and baking powder together.
2. Whisk cream lightly in a separate bowl, add sugar.
3. Mix in the rest of the ingredients except the whole almonds. Knead lightly to a pliable dough.
4. Roll out into a big thin round and cut into shapes your desire.
5. Stick an almond on each biscuit and bake in a moderate oven for 15 minutes till pale brown.

Coconut Currant Bites

Ingredients

Maida	:	1½ cups
Soda bicarb	:	½ tsp

Baking powder	:	½ tsp
Egg	:	1
Butter	:	¼ cup
Sugar	:	1 cup
Curd	:	½ cup
Currants	:	½ cup
Vanilla essence	:	A few drops
Desiccated coconut	:	1 cup

Method of Preparation

1. Sieve maida with baking powder and soda bicarb.
2. In a separate bowl, beat the egg. ix in sugar, butter, curd and essence on by one.
3. Mix in the rest of the ingredients except the desiccated coconut. Drop spoonfuls on greased baking tray.
4. Dab coconut over it, press lightly and bake in a moderated oven for 15 minutes.
5. Cool thoroughly.

Sweet Canapes

Ingredients

Bread	:	4 slices
Butter	:	2 tbsps
Butter	:	½ cup
Honey	:	½ cup

Nuts, finely chopped

Method of Preparation

1. Remove the crust from the slices of bread and butter them. Cut each slice into 2 long pieces. Butter the slices.
2. Mix nuts with the honey, spread nut mixture over bread pieces.
3. Roll tem up with wet hands, use tooth pick, if required.
4. Pour a little butter or oil over each canape. Toast in the oven.
5. Serve hot with honey poured over them.

Queen of Puddings

Ingredients

Fresh, white bread crumbs	:	1 cup
Milk, scalded	:	2 cups
Eggs, separated	:	2
Sugar	:	½ cup

Mixed fruit jam	:	3 tbsps
Bananas, sliced	:	1 cup
Cream		

Method of Preparation

1. Place breadcrumbs in a bowl with hot milk and let stand for 10 minutes.
2. Beat egg-yolks with half the sugar and stir into crumb mixture.
3. Pour the mixture or until firm to the touch.
4. Combine the jam and banana slices and spread over the baked mixture.
5. Whip egg whites until stiff and then beat in remaining sugar to form a meringue. Swirl meringue over top.
6. Increase oven temperature to moderately hot and bake pudding for 8-10 minutes or until meringue is set and lightly browned.
7. Serve hot or warm by itself or with cream.

Egg Less Chocolate Cake

Ingredients

Refined flour	:	½ cup
Baking powder	:	1 tsp
Cocoa powder	:	2 tsp
Drinking chocolate	:	2 tsp
Soda bicarb	:	¼ tsp
Water	:	75 ml
Vanilla essence	:	1/8 tsp
Condensed milk	:	½ tin

Method of Preparation : Butter

1. Grease and dust 18 cm square tin (mould) and keep aside.
2. Sieve together flour, baking powder, cocoa powder, drinking chocolate and soda bicarb thrice and keep aside.
3. Mix water and Vanilla essence and keep aside.
4. Mix condensed milk and butte, beating continuously in one direction.
5. Add 1tbsp of the sieved flour mixture into the beaten mixture. At the same time, add the water mixture into the beaten mixture. Continue doing the same until the sieved mixture is over.
6. Fold the cake batter into the greased and dusted tin. Place the tin into the drip/ baking tray.
7. Bake at 180° C. Bake for 15 minutes or till done.
8. Cool on wire rack and serve

WARRANTY

The INALSA "OTG" is fully warranted against any manufacturing defect for a period of TWO YEARS from the date of purchase. Should any defect develop in the OTG during the warranty period, Tuareg Marketing Pvt. Ltd. undertakes to get the OTG or any part thereof, repaired at any of its authorised service center.

The above warranty shall be subject to the following terms and conditions:-

1. Any defective product or part thereof will be repaired within the above stated warranty period on receipt of the same with this card duly filled in and stamped by dealer from whom the product was purchased along with the purchase bill/ invoice, provided the product is brought to our nearest service center freight paid and packed securely.
2. In the event of repairs/ replacement of any part of product, this warranty will thereafter continue and remain in force only for the unexpired period of warranty.
3. This warranty is valid only when:-
 - The product is purchased from the company's authorized dealer and accompanied by this warranty card/ cash memo.
 - The product has been serviced by the Inalsa's authorized service personnel.
 - The product has been used and maintained in accordance with the instruction manual.
4. The warranty does not apply to :-
 - Normal wear and tear of the product
 - Damage due to chipping, peeling, plating and denting.
 - Damages arising due to running of the appliances on the alternate sources of power such as Inverter, generator or any such auxiliary power supply aid resulting in variation/ fluctuating voltage
 - Breakage or damage to components made of ABS, SAN, Bakelite, Glass and such plastic/rubber parts, cord, bulbs and surface coating.
 - Damages resulting from accidents, mishandling or negligence on the part of the customer
 - Product if used for the commercial purposes.
 - Product, the serial number of which has been removed obliterated or altered on the specification plate.
5. The warranty is in lieu of all other warranty, expressed or implied and does not cover indirect or consequential damages/ loss.

WARRANTY CARD

Product : Oven Toaster Griller

Model : Master Chef 10BK Quick Chef 10BK
 Master Chef 16BK Quick Chef 16BK
 Master Chef 19BKR Quick Chef 19BKR
 Master Chef 24RSS
 Master Chef 30SSRC
 Master Chef 46SSRC

Serial No.....

Date of purchase.....

Bill/ Cash Memo no.....

Purchaser' name.....

Address.....
.....

Dealer's stamp and Signature

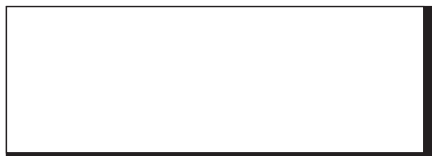

Customer Care Number (Timing: 9:30 to 5:30) (Mon - Sat)
9773982065

INALSA

TUAREG MARKETING PVT. LTD.
154, Bhalswa, Delhi- 110033