

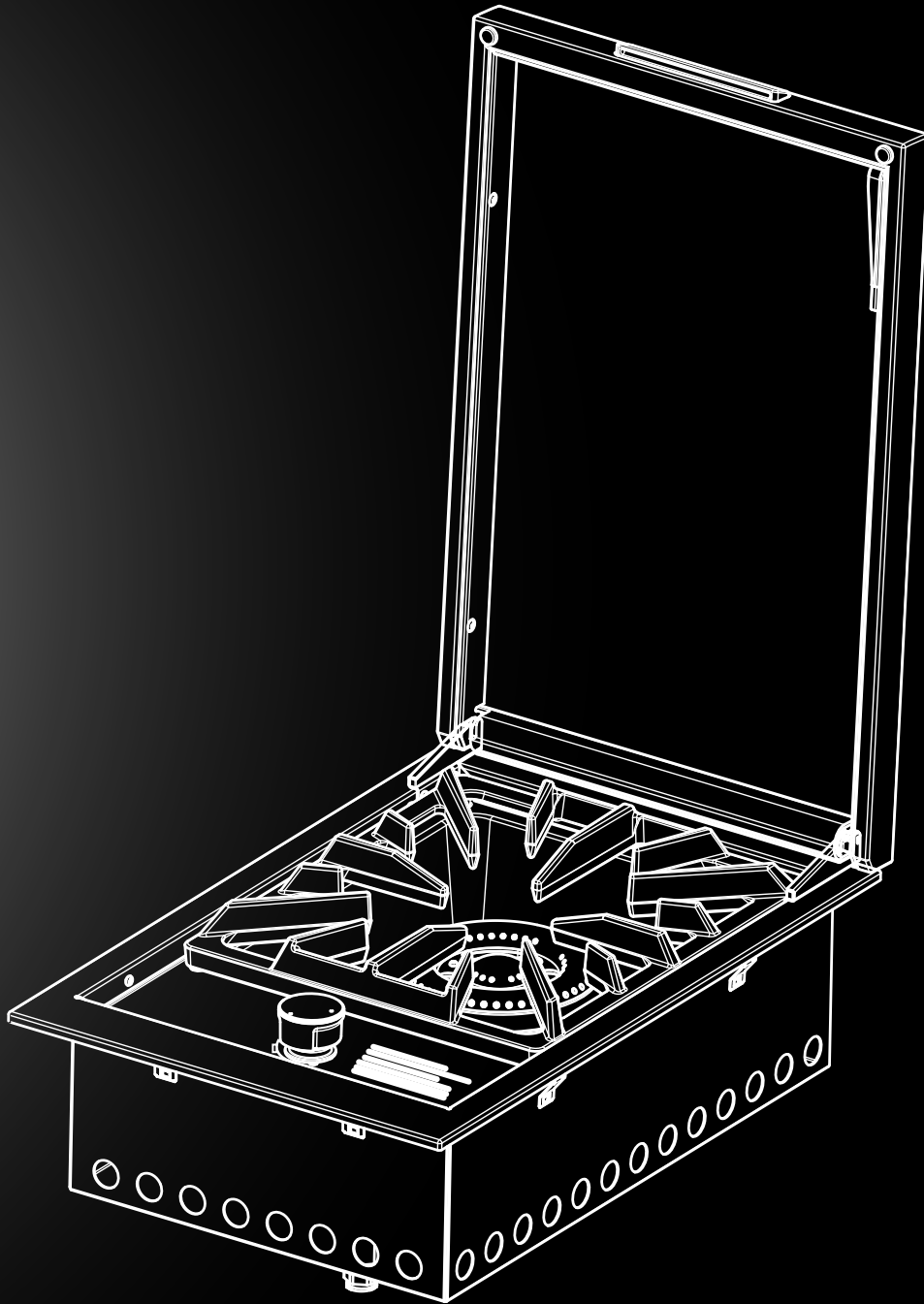

Assembly and Operating Instructions

INTEGRATED SIDE BURNER

BSW318SA



AUSTRALIA / NEW ZEALAND



Dear customer,

Congratulations and thank you for choosing our appliance. We are sure you will find it a pleasure to use. Before you use the appliance, we recommend that you read through the relevant sections of this manual, which provide a description of your appliance and its functions.

To avoid the risks that are always present when you use an appliance, it is important that the appliance is installed correctly and that you read the safety instructions carefully to avoid misuse and hazards.

We recommend that you keep this instruction booklet for future reference and pass it on to any future owners.

After unpacking the appliance, please check it is not damaged. If in doubt, do not use the appliance but contact your local customer care centre.

This appliance complies with requirements of Australian Standards AS4563.

CONDITIONS OF USE

These important notes apply to your appliance, failure to adhere to these conditions of use may affect your ability to make a claim under the manufacturer's warranty.

- This appliance **MUST** be installed and serviced only by a qualified licensed person.
- This product is intended for installation and use at a domestic residence only. This product is not intended for commercial use.
- This product is not suitable for installation or use in marine craft, caravans or recreational vehicles.
- This product must be installed in accordance with these instructions, the requirements of AS/NZS 5601.1 and in accordance with local authority.
- This product must be installed, operated and maintained as per the instructions.
- Ventilation holes in the unit must not be obscured by the installation.

Please ensure you read the instruction manual fully before you call for service, or a full service fee could be applicable.

Record model and serial number here:

Model number:

Serial number:

PNC:

General warnings	3
Product description	4
Gas specifications	6
Gas connection detail	6
Natural gas installation	7
Leak test procedure	7
Universal LPG installation	8
Gas bottle safety	9
Installation warnings	10
Installation instructions	11
Dimensions	12
Gas requirements	13
Positioning of burner	13
Connecting to the integrated barbecue	14
Burner operation	15
Pivoting safety leg	15
Cleaning and care	16
Troubleshooting	17
Accessories	17
Notes	18
Warranty	19

Please read the user manual carefully and store in a handy place for later reference.

The symbols you will see in this booklet have these meanings:



WARNING

This symbol indicates information concerning your personal safety.



CAUTION

This symbol indicates information on how to avoid damaging the appliance.



IMPORTANT

This symbol indicates tips and information about use of the appliance.



ENVIRONMENT

This symbol indicates tips and information about economical and ecological use of the appliance.

IMPORTANT INFORMATION THAT MAY IMPACT YOUR MANUFACTURER'S WARRANTY

Adherence to the directions for use in this manual is extremely important for health and safety. Failure to strictly adhere to the requirements in this manual may result in personal injury, property damage and affect your ability to make a claim under the BeefEater manufacturer's warranty provided with your product. Products must be used, installed and operated in accordance with this manual. You may not be able to claim on the BeefEater manufacturer's warranty in the event that your product fault is due to failure to adhere this manual.



IMPORTANT SAFETY INSTRUCTIONS

Please read the user manual carefully and store in a handy place for later reference.



IMPORTANT

Important – check for any damages or marks

If you find the appliance is damaged or marked, you must report it within 7 days if you wish to claim for damage/marks under the manufacturer's warranty. This does not affect your statutory rights.



ENVIRONMENT

Information on disposal for users

- Most of the packing materials are recyclable. Please dispose of those materials through your local recycling depot or by placing them in appropriate collection containers.
- If you wish to discard this product, please contact your local authorities and ask for the correct method of disposal.



WARNING

This appliance must be serviced only by a qualified licensed person.

Improper installation, adjustment, alteration or maintenance can cause injury or property damage.

Please contact your nearest Electrolux Service Department for additional information or assistance for an approved installer.

NOTE: This manual must remain with the owner for future reference.



IMPORTANT

Flame Failure - Auto Shut Off Safety System

Operating Instructions

For added gas safety, your barbecue is fitted with Flame Failure Technology. This safety system will shut off the gas supply to an individual burners if the flame goes out for any reason.

How It Works

Flame Failure Technology switches gas off to an individual burner if the flame goes out. During normal operation the burner flame is in contact with the sensor probe. If the flame is blown out by a strong breeze for example, the control valve will shut off the gas supply to the burner to avoid a continuous .



WARNING

- Do not lean over appliance when lighting.
- Do not leave the appliance unattended when alight.
- Do not delay lighting once the gas has been turned on.
- Do not store or use aerosol cans in the vicinity of the appliance.
- Do not store flammable liquids in the vicinity of the appliance.
- Do not use caustic or abrasive based cleaners on the appliance.
- Do not attempt to dismantle or adjust the control valves.
- Do not attempt to dismantle or adjust the regulator.
- Do not test for leaks with a naked flame.
- Do not modify the construction of this appliance or modify the injector orifice size.
- Do not obstruct any ventilation of the appliance.
- Do not allow children to operate or play near the appliance.
- This appliance is not suitable for caravans or boat installation.



CAUTION

This appliance is supplied set up for Natural Gas and is labelled accordingly. A Universal LPG conversion kit is included if required. Conversion of this unit to Universal LPG must be carried out by a qualified licensed person and a Certificate of Compliance must be issued to the owner at the completion of the installation and conversion.

PRODUCT DESCRIPTION

Integrated burner

- ① Slimline lid
- ② Gas connection point

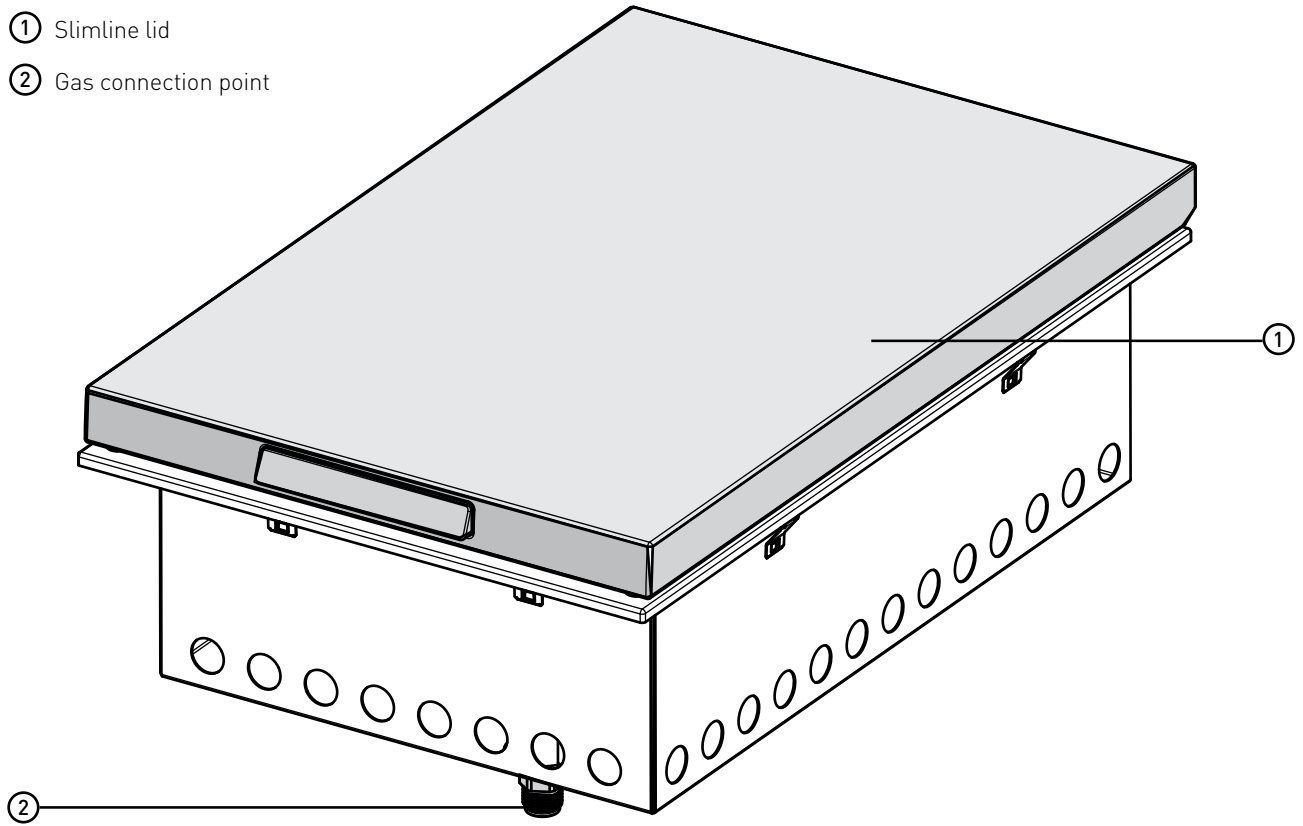

PRODUCT DESCRIPTION

- ③ Pivoting lid safety leg
- ④ Lid mounting bracket
- ⑤ Trivet
- ⑥ Burner
- ⑦ Burner control

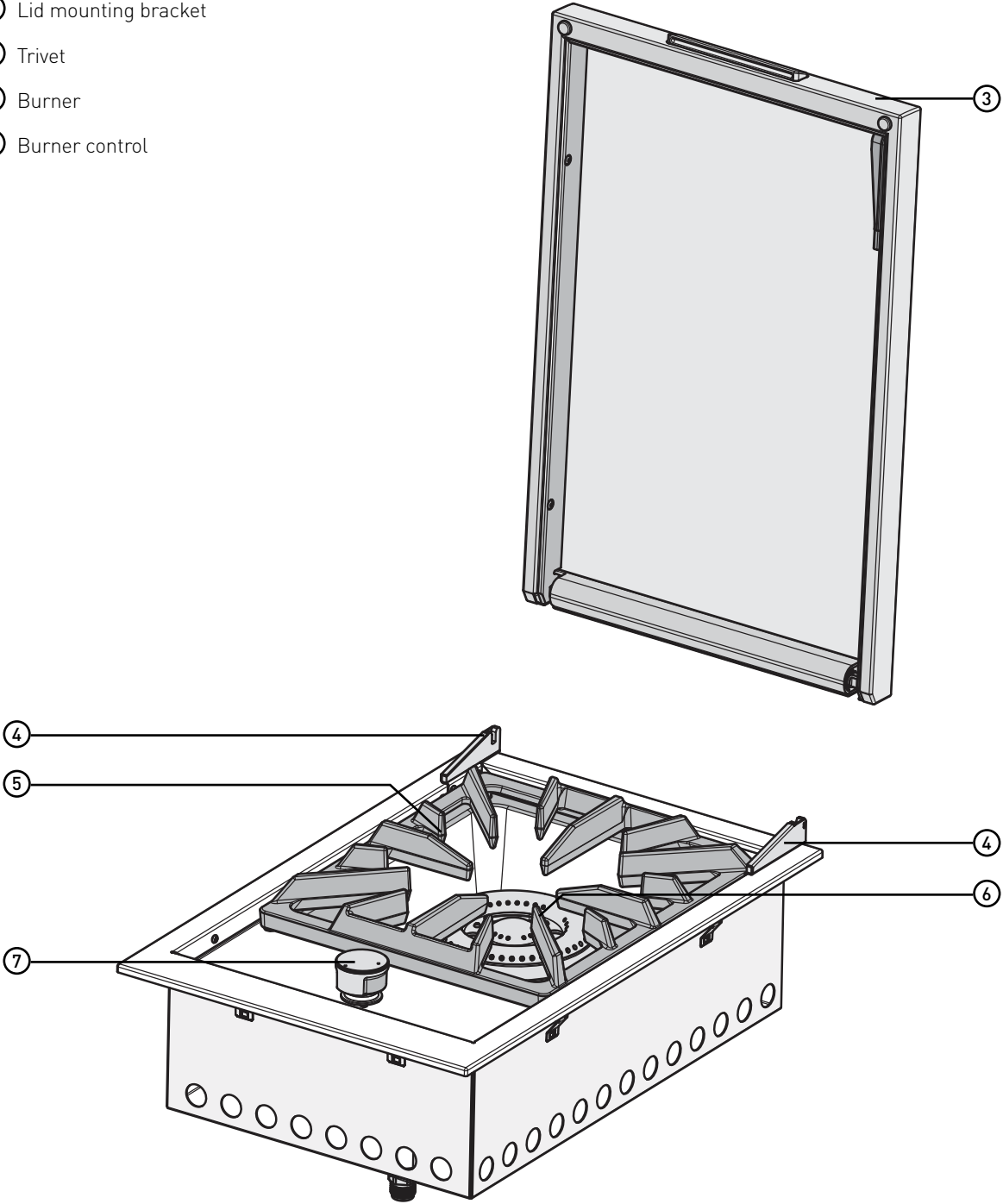

GAS SPECIFICATIONS

GAS TYPE	NATURAL GAS	UNIVERSAL LPG
Maximum gas consumption	21 MJ/h	23 MJ/h
Injector orifice diameter	2.20mm	1.30mm
Number of injectors	1	1
Regulator pressure	1.00 kPa	2.75 kPa

NOTES:

- This appliance **MUST** be installed and serviced only by a qualified licensed person.
- This appliance must be installed in accordance with these instructions, Australian Standard AS/NZS 5601, and local authority.
- This product must be installed as per the instructions which requires the installation of venting to enable the appliance to operate correctly. Failure to provide adequate ventilation for supply of air to the appliance may result in poor burner performance or excessive heat build-up within the mounting enclosure.
- Ventilation holes in the unit must not be obscured by the installation.

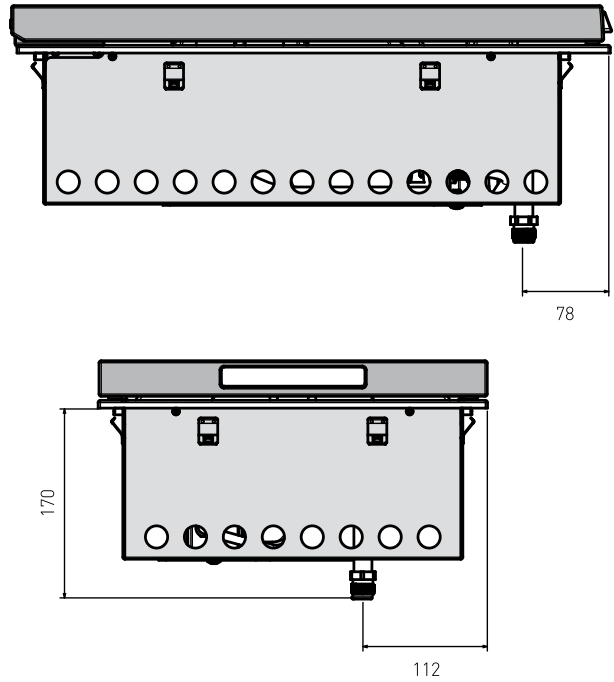

This appliance is supplied set up for Natural gas and is labelled accordingly. A Universal LPG conversion kit is supplied if required. Refer to Universal LPG installation for details.

Connecting the appliance to an NG gas supply

Components supplied in a bag for NG are:

- Natural gas regulator
- Natural gas installation pipe
- 2 x fibre washers

Preparing the unit for Natural Gas connection to mains

Natural gas connection to be made by a licensed gas fitter.

Preparing the unit for Natural Gas installation

Fit natural gas installation pipe to the gas inlet to enable access to the regulator in the installed position. When tightening the regulator or any other connection do not over-tighten.

1. Fitting the natural gas installation pipe.
Fit pipe ensuring the blue fibre washer is in place. Do not over-tighten.
2. Fitting the regulator.
Fit the regulator ensuring the blue fibre washer is in place and the arrow indicating the gas flow is correct. Do not over-tighten.
3. Connect to consumer piping.
 - The NG regulator inlet has a 1/2" parallel pipe thread.
 - The inlet of the NG regulator may be connected to consumer piping using a suitable hose assembly if required.

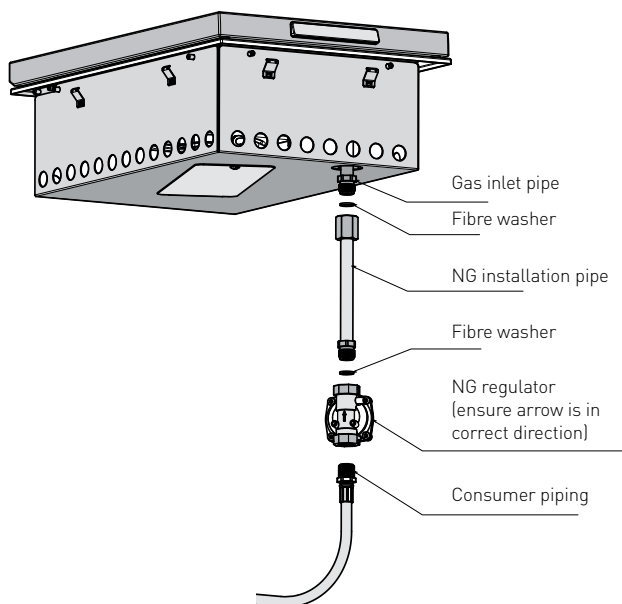

- Ensure gas valve is in the 'OFF' position.
- In a small container, mix a solution of water and detergent or soap.
- After connection of the hose, turn on the gas supply at the gas bottle or mains as appropriate.
- Using a brush apply the solution to the gas connection points and look for bubbles forming.
- Bubbling will indicate a leak.
- Turn off the gas supply and re-tighten the joint. Repeat the leak test.
- If the leak persists, turn off the gas at the isolation valves and contact a licensed gas fitter to correct.

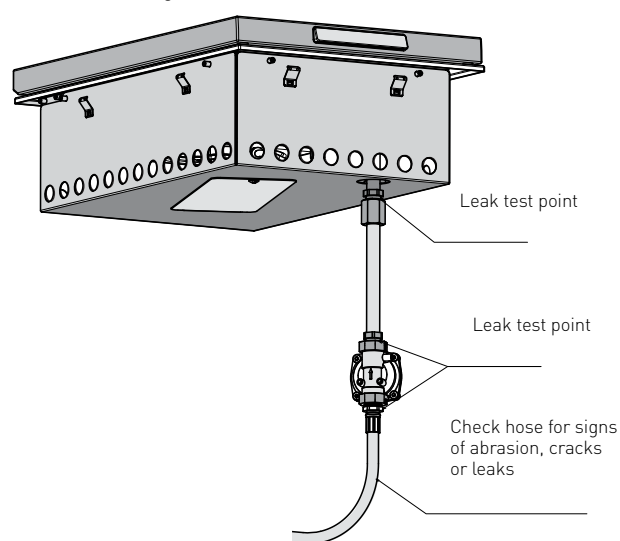

WARNING

Failure to ensure gas tight connections and complete the gas leak test procedure before use and after every reconnection to a gas cylinder may result in a fire or explosion.

UNIVERSAL LPG INSTALLATION

NOTE: Conversion of this unit to Universal LPG must be carried out by a qualified licensed person and a Certificate of Compliance must be issued to the owner on completion of the installation and conversion.

Converting the Unit to Universal LPG

This appliance is supplied set up for Natural gas and is labelled accordingly. A Universal LPG conversion Kit is supplied with the product.

The components required for conversion are:

- Brass adaptor.
- Fibre washer.
- Small plastic bag containing:
 - 1 x 1.30mm brass injector
 - LPG sticker

Procedure

1. Remove screw and cover panel on base of burner box.

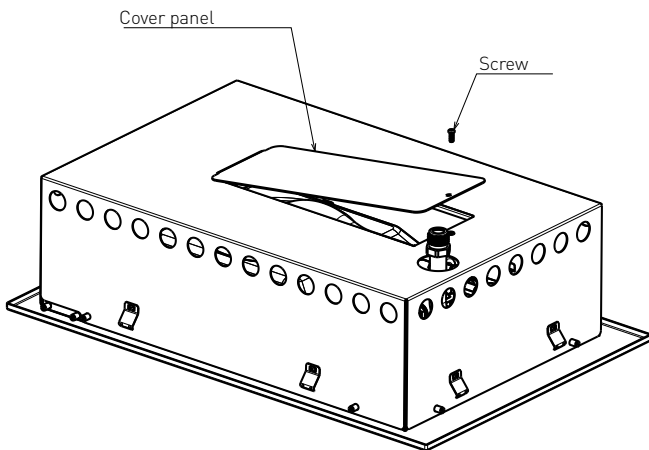

2. Remove two screws fastening burner.

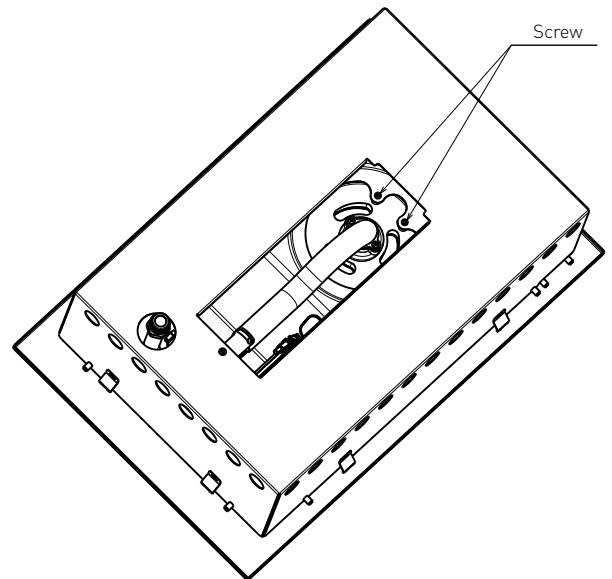

3. Remove burner from burner box.

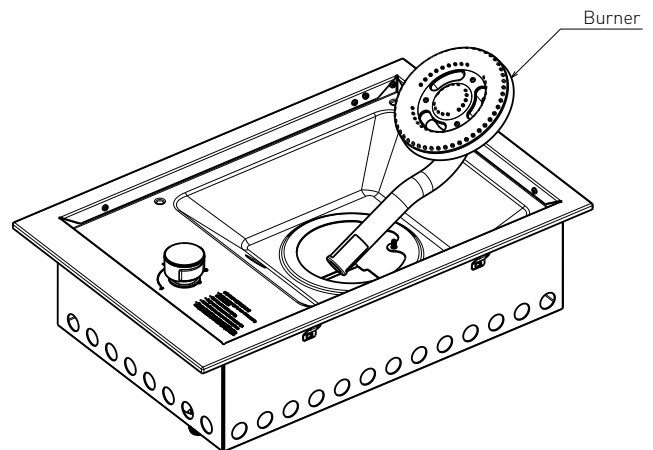

4. Replace gas injector with appropriate size injector (refer to Gas Specification Table on page 6).

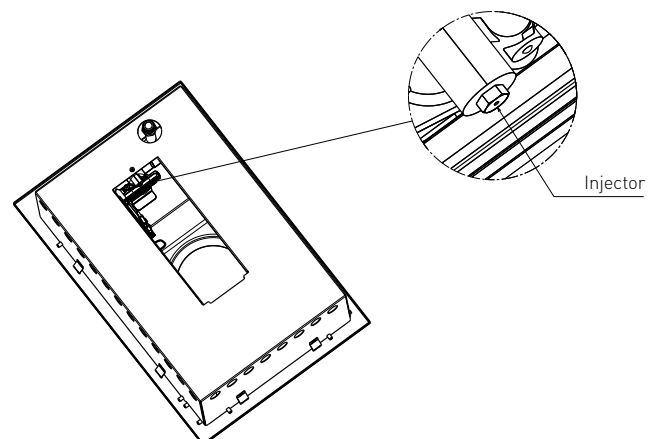

- The factory setting for the primary air shutter is fully open, and should not be modified. Ensure the primary air shutter is fully open before replacing the burner.

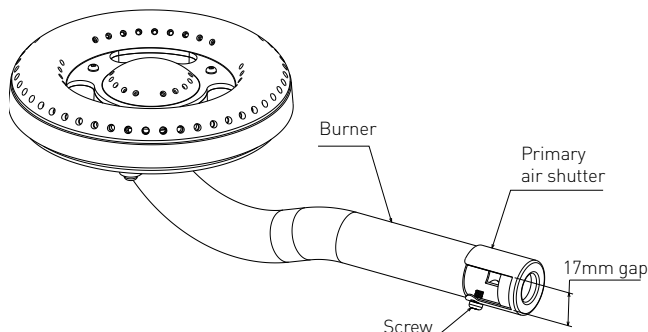

- Replace burner and cover panel.
- Remove Natural Gas sticker on the base panel and replace with Universal LPG sticker provided.

The final step in the conversion of the appliance to Universal LPG is the adjustment of the turndown setting. This can only be completed after the appliance has been connected to a supply of Universal LPG. Connecting to a Portable 9kg LPG Cylinder or Connecting to remote supply of LPG.

Adjust the turndown setting on the valve.

To complete the conversion to Universal LPG the turndown setting of the valve will need to be adjusted, and at the same time the operation of the appliance can be tested. Proceed as follows:

- Check that the burner ignites (REFER OPERATING INSTRUCTIONS).
- Light the burner and rotate the control knob to the lowest setting, then remove the knob from the valve shaft, and remove the grommet.
- Using a small flat-blade screwdriver adjust the turndown adjustment screw to achieve a small steady flame on the burner.
- Replace the grommet and the knob.

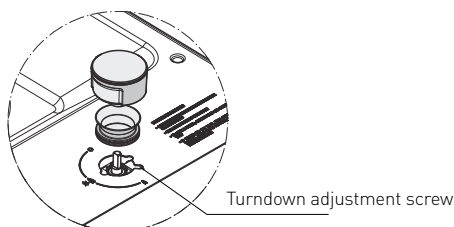

- Recheck the operation of the burner at maximum and turndown.

Connecting the appliance to an LPG gas supply

The appliance may be supplied LPG from either:

- A 9kg portable LPG cylinder, or
- A remote supply of LPG via fixed pipework.

Gas bottle safety information

- This appliance is designed to use a 9kg (20 lbs) gas cylinder.
- The gas cylinder must be made and marked in accordance with specifications for LPG or Propane cylinders.
- It is recommended to turn off the cylinder valve when the appliance is not in use.
- Gas cylinders must be stored in an approved housing out of reach of children.
- When disconnecting the gas bottle ensure that all the control valves are in the 'OFF' position.
- Remove the bottle from any housing in which it may be stored before disconnection.
- When reconnecting the hose to the bottle, ensure that all connections are tight before replacing in the storage compartment.
- Carry out a leakage check as detailed below after each reconnection.

Connecting to a Portable 9kg LPG Cylinder

The components required to make this type of connection are included.

The components required are:

- LPG hose and regulator assembly to suit 9 kg cylinder
- Brass adaptor
- Sealing washer.

To assemble the connection (refer diagram below):

- Connect the brass adaptor to the appliance gas inlet with the sealing washer in place to seal the connection. Then assemble the hose to the brass adaptor.
- Connect the POL fitting at the inlet of the regulator to the valve on the LPG cylinder.
- Leak test all connections in the assembly as described under LEAK TEST PROCEDURE.

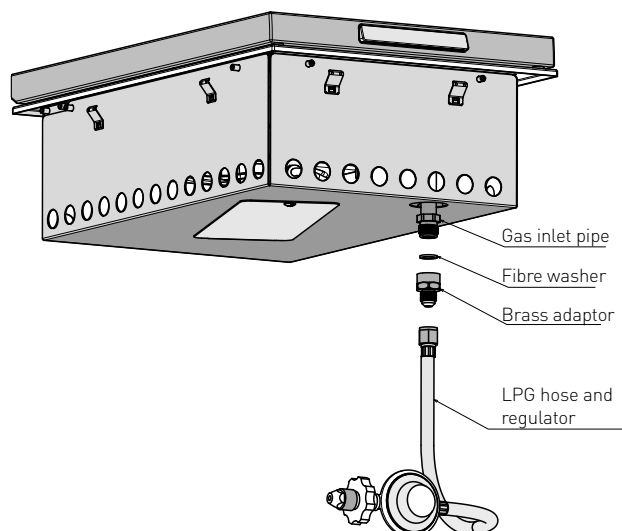

Connecting to a remote supply of LPG

The components required to make this type of connection are available as an accessory and can be purchased either on the Electrolux spare parts website or by contacting the Electrolux Customer Service Centre. Refer to Accessories section on page 17.

Never connect the appliance to an unregulated LPG supply. Ensure that the supply pressure at the inlet of the appliance is 2.75kPa.

BeefEater strongly recommends installation of a manual shut-off valve, or hose assembly with a certified quick connect that is accessible with the appliance installed, so that the appliance may be isolated from gas in the event of an emergency or for servicing.

The components required are

- Brass test point adapter
- Sealing washer

To assemble the connection:

- Connect the brass test point adapter to the appliance gas inlet with the arrow on the adapter oriented according to direction of gas flow, with the sealing washer in place to seal the connection.
- The inlet to the adapter has a standard internal 1/2" pipe thread and can connect to any standard external 1/2" tapered threaded connection. This connection is sealed with any thread tape or sealing compound that is suitable for gas connections. Connect the fixed LPG pipework to the inlet of the test point adapter by any suitable means in accordance with requirements of AS/NZS 5601.1.
- Leak test all connections in the assembly as described under LEAK TEST PROCEDURE.

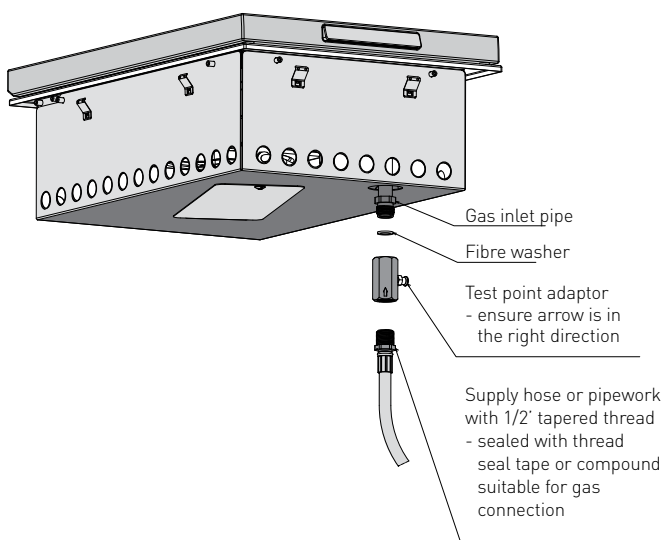

WARNING

- This appliance may be installed outdoors, under cover, or in an outdoor kitchen or outdoor living area.
- Outdoor areas where this appliance is located may be enclosed by blinds, partitions or similar for the purpose of weatherproofing.
- This appliance must not be installed or used in a boat, caravan or recreational vehicle.
- This appliance must not be installed or used inside an inadequately ventilated building. Building ventilation must comply with Clause 5.13 of AS/NZS 5601.1. This is to prevent the possibility of fire, carbon monoxide poisoning or asphyxiation

INSTALLATION INSTRUCTIONS

When planning the location and preparing the installation structure for this appliance note the following:

- This appliance is Certified to AS 4563, and Clause 6.10.2 of AS/NZS 5601.1 is applicable.
- Requirements in these instructions for clearances to combustible materials also apply to combustible materials that have non-combustible materials attached to their surface.
- This appliance must be installed such that no part of the appliance is in contact with or within 10mm of any combustible material.
- The minimum clearance to a vertical wall above bench level made from a combustible material is 250mm.
- The vertical clearance above the cooking surface to any combustible materials must be at least 1000mm.
- When using LPG in an enclosure ventilation must be provided. Gas is highly explosive and can cause serious injury and damage to property if allowed to accumulate and then be ignited.
- This appliance is intended to be built into a benchtop with a minimum depth (front to rear) of 600 mm.
- Avoid windy positions as this will affect cooking performance and burner efficiency. If this situation cannot be avoided some shielding may be necessary.

The mounting enclosure

- The appliance requires a non-combustible barrier under the appliance to prevent excessive temperatures being accessed. The barrier panel is to be placed at least 30mm under the base of unit.
- The benchtop that supports the appliance must be constructed from non-combustible material. Suitable materials include masonry, granite, marble, Hardiplank®, Villaboard® over a metal frame, or tiles on a non-combustible substrate.
- There shall be at least 250mm clearance between the appliance and any part of the benchtop made from combustible material.
- This appliance requires venting. Refer to diagrams {on next page} for vent specification and location.
- For ULPG use, cabinetry below the appliance must have low level venting to prevent the possibility of LPG accumulating.
- Ensure there is a minimum of 20mm clearance on all sides, between the sides of the appliance and the support structure.

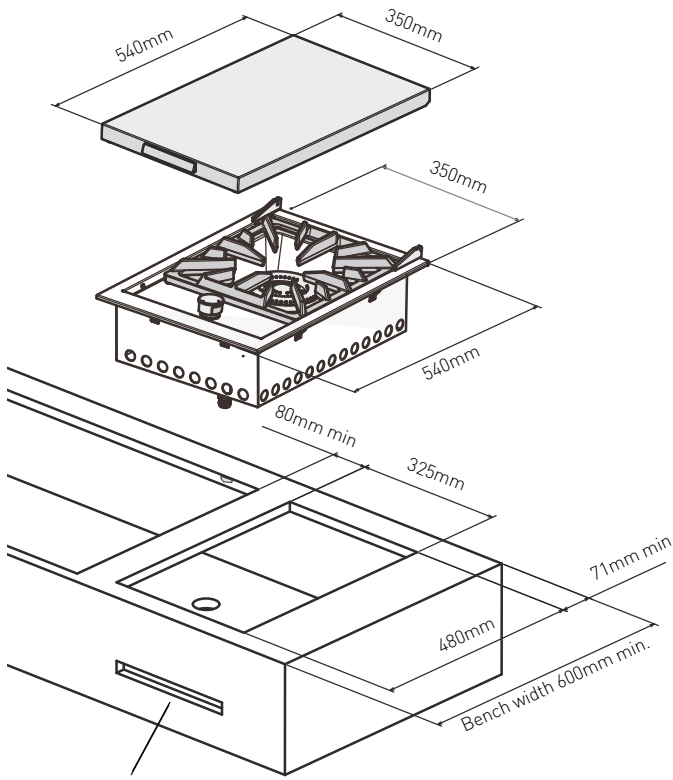

Vent 250mm x 25mm (required when installed separately to barbecue)

! WARNING!

- This appliance requires venting. This vent is to allow air into the enclosure for the correct combustion of gases and for the correct exhausting of the products of combustion. The vent must be no less than 250mm x 25mm unless installed adjacent to integrated barbecue refer to diagram on page 13.

Side view - lid up

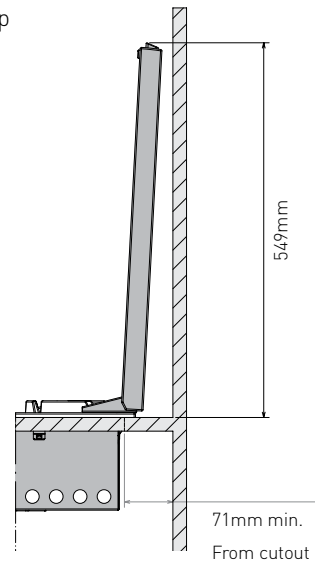

Side view - lid down

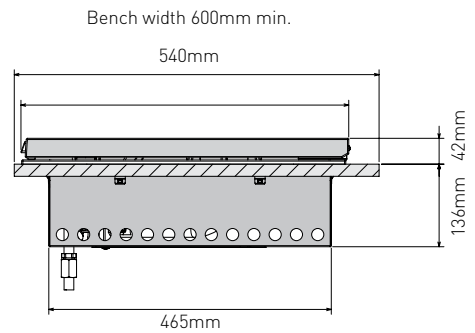

Natural Gas requirements

- The enclosure must be constructed so that access can be gained to the Natural Gas regulator at all times.
- For pipe sizing requirements for supply pipe refer to AS/NZS 5601.1.

Universal LPG requirements

- If an LPG bottle is to be stored in the enclosure under the burner unit, it must be isolated from the burner unit with a non-combustible panel. The enclosure must comply with the requirements of AS/NZS 5601.1.
- AS/NZS 5601.1 ventilation requirements for cylinder storage are:
 - Where of sheet metal or similar impervious construction there shall be ventilation openings at the top and bottom of the enclosure or recess, each opening providing a free area of at least 200cm² for every cylinder enclosed.
- For ULPG installations having enclosed cabinetry below the separation panel that does not contain a gas bottle, low level venting must be installed. This is to allow the gas which is heavier than air escape from the enclosure in the situation where there may be a leak. A minimum opening of 200cm² is required.

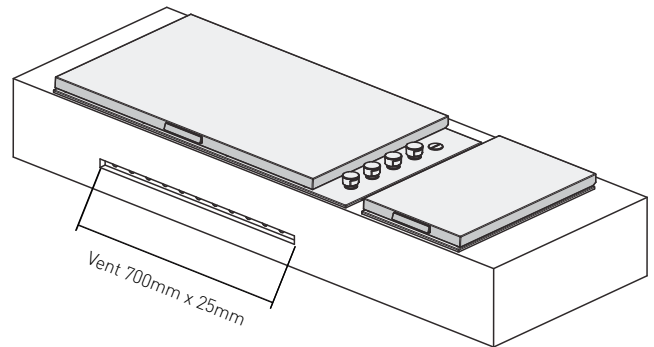

When installing integrated burner with the integrated barbecue, ventilation to the side burner can be achieved from one common vent (as shown above). Provided there is no restriction of airflow in the enclosure construction (i.e. no separation panel between barbecue and side burner).

A minimum clearance of 80mm (as shown on page 12) must be observed. This prevents heat transfer between units.

Refer to manufacturer's instructions for construction requirements of specific bench top materials.

CONNECTING TO THE INTEGRATED BARBECUE

If the integrated burner is located adjacent to the built in barbecue and the units are to be connected to the same outlet or cylinder, the gas line must branch off prior to the regulator. Each appliance must have its own regulator.

For Natural Gas

This can be achieved with hard plumbing to each of the regulators.

From the regulator to the appliance the connection method remains unchanged.

For Universal LPG

This is achieved by adding fittings to branch off at the cylinder connection on the high pressure side. To each branch the regulator and hose assembly is fitted for each appliance. From the regulator and hose assembly to the appliance the connection method remains unchanged.

This appliance must be installed by a qualified licensed person. For piping size requirements for supply pipe refer to AS/NZS 5601.1.

Control functions

Before lighting the burner:

- Check that all hoses and gas fittings are tight.
- Remove or pivot lid to open.

NOTE: The lid is designed as a cover for weather protection. The lid is not designed to be used as a cooking hood.

- Check control knob is in the 'OFF' position.
- Ensure that the cooking surfaces are clean.
- Ensure that the gas isolation valve or the LPG bottle are 'ON'.

Lighting instructions

- Do not attempt to light burner with the cooking surfaces covered.
- To light burner, depress the knob and rotate to 'BOOST'.
- If burner did not light, turn knob to the 'OFF' position. Allow gas to disperse, then repeat lighting procedure.

Manual lighting

- If, in the event of the ignition system not working, the burner can be lit manually.
- Rotate the knob to the 'BOOST' and place a lighted match near to the burner.
- If the unit does not operate correctly refer to the troubleshooting section on page 17.

To turn the burner off

- When cooking is complete, rotate the knob fully clockwise so the pointer on the knob is positioned at the off position.

WARNING!

Ensure the cast trivet is in the correct orientation with the 4 feet on the trivet located into the recess in the hob. The height of the trivet is critical for burner operation.

To ensure that the user remembers to turn off the gas before closing the lid, a pivoting safety leg has been fitted.

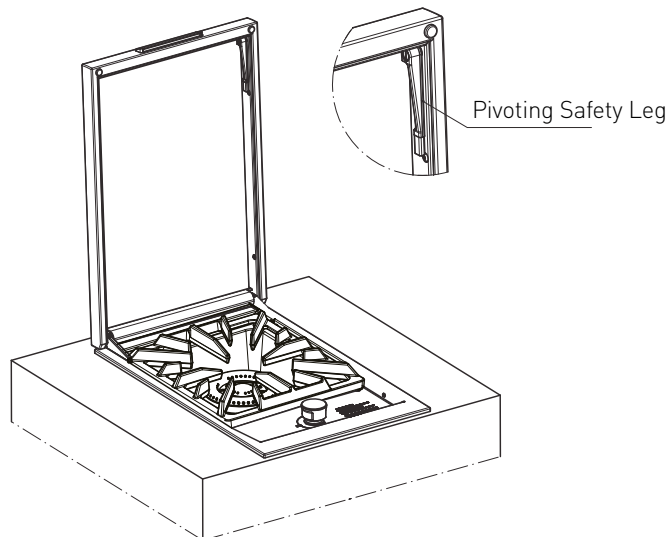

When closing the lid the safety leg will pivot forward and rest against the trim surface to prevent the lid closing. After ensuring the gas has been turned off, to fully close the lid, the leg needs to be rotated backwards.

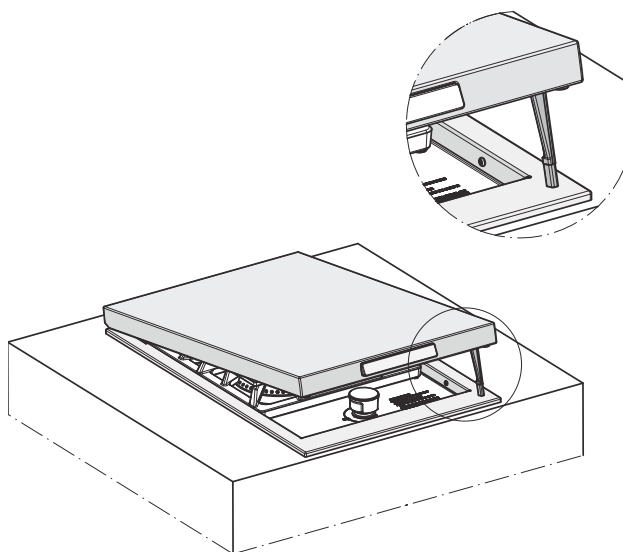

WARNING!

THE SLIMLINE LID MUST NOT BE CLOSED WHEN THE BURNER IS OPERATING.

Closing the lid during burner operation can cause discolouration and damage to the lid and burner unit.

CLEANING AND CARE

The Beefeater integrated burner has been constructed from select grade stainless steel which, if not cared for, may discolour over time. To keep your appliance looking its best we recommend that the cooking surfaces are cleaned after every use.

Cleaning

- Always ensure the appliance is turned off before cleaning.
- This appliance contains brass and aluminium fittings. Do not use caustic based cleaners.
- Do not use steam cleaners as this may cause moisture build up on electrical components.
- Always clean the appliance immediately after any food spoilage.



CAUTION

Do not place cast iron trivet or grill plate in a dishwasher.



WARNING

Please ensure that your appliance is switched off and has cooled down before following the instructions below.

Cleaning of Stainless Steel surfaces



CAUTION

Do not use abrasive or caustic cleaners, scourers or metal scrapers on these stainless steel surfaces as they may permanently scratch and damage your barbecue. Take particular care around the control knob graphics and instructions.

- Wash all stainless steel components, including the slimline lid and control knob cap with a soft dishcloth using hot soapy water.
- The interior can be wiped down with a soft cloth in hot soapy water.
- Ensure that all surfaces are dried with a clean dry cloth.



CAUTION

Take extra care (particularly when cleaning on and around the control knob) to ensure that water and soapy residue do not enter the control panel, where the valve is located or into the burner.

Trivet and reversible grill plate

The trivet can be removed for cleaning. Clean by washing in warm soapy water. Take care when replacing the trivets as dropping them may damage the enamelled surfaces.

Burner

The burner ports should be checked for blockages and cleared as required. The brass top of burner will become discoloured with use, this is normal.

Maintenance



IMPORTANT

Special note on "tea staining"

Sometimes stainless steel surfaces are affected by a brown discolouration called tea staining. This usually occurs in areas which use high heat and can be easily removed using specialised stainless steel cleaners. For best results, we recommend that specialised cleaners be used regularly on all stainless steel components.

Burners

Burners should be checked at least once per year and cleaned as necessary. Inspect burners to ensure no residues have been deposited and gas ports are clear.

NOTE: Environmental conditions need to be taken into account with regards to the maintenance required on your product. In particular units installed in humid climates or seaside locations will be more susceptible to surface corrosion/discolouration over time. In these conditions BeefEater strongly recommends cleaning and drying your barbecue after every use and covering it when not in use to minimise exposure to the elements. Surface corrosion can be removed by using a specialized stainless steel cleaner.

Speak to your local Authorized Service Centre periodically to check the conditions of the gas supply pipe and the pressure adjuster, if fitted. An AGA certified class A flexible connection may be used to connect the barbecue with LPG.



PROBLEM	POSSIBLE CAUSE	REMEDY
Appliance won't light	No gas	Check isolation valve is ON Gas bottle empty - refill or change gas bottle
	Ignition system not working	Ignition electrode wet or dirty Manually light the burner
Flame not staying on when knob is released	Knob not held down long enough for flame safeguard to engage	Repeat lighting procedure and hold knob down for 5 seconds
	Port blockage adjacent to thermocouple	Check the flame is present and the tip of the thermocouple is heated by the flame
Excess smoke being emitted from the cooking area	Gas valve set too high	Turn gas valves down or turn off the burner
Smell of gas DO NOT ATTEMPT TO LIGHT THE APPLIANCE	Gas leak	Turn off gas at the isolation valves
		Check for leaks, tighten joints
		If problem persists call Electrolux Service

To order any of the following accessories and spare parts, or for more information on any other suitable accessories for this product, please contact the Electrolux Customer Service Centre.

ACCESSORIES
standard inclusions+
gas conversion kit - Universal LPG
optional extras *
cast iron reversible grill plate
weatherproof cover (for model BSW318SA)

+ Standard inclusion with the product but can also be purchased separately via the Electrolux Customer Service Centre.

* Sold separately via the Electrolux Customer Service Centre. For the full range of accessories please visit beefeaterbbq.com



Electrolux Warranty

FOR SALES IN AUSTRALIA AND NEW ZEALAND
APPLIANCE: BEEFEATER SIGNATURE BBQ, ALFRESCO KITCHEN

This document sets out the terms and conditions of the product warranties for BeefEater Appliances. It is an important document. Please keep it with your proof of purchase documents in a safe place for future reference should there be a manufacturing defect in your Appliance. This warranty is in addition to other rights you may have under the Australian Consumer Law.

1. In this warranty:

- (a) 'ACL' or 'Australian Consumer Law' means Schedule 2 to the Competition and Consumer Act 2010;
- (b) 'Appliance' means any Electrolux product purchased by you and accompanied by this document;
- (c) 'ASC' means Electrolux's authorised serviced centres;
- (d) 'BeefEater' is the brand controlled by Electrolux Home Products Pty Ltd of 163 O'Riordan Street, Mascot NSW 2020, ABN 51 004 762 341 in respect of Appliances purchased in Australia and Electrolux (NZ) Limited (collectively "Electrolux") of 3-5 Niall Burgess Road, Mount Wellington, in respect of Appliances purchased in New Zealand;
- (e) 'Warranty Period' means the period specified in clause 3 of this warranty;
- (f) 'you' means the purchaser of the Appliance not having purchased the Appliance for re-sale, and 'your' has a corresponding meaning.

2. Application: This warranty only applies to new Appliances, purchased and used in Australia or New Zealand and is in addition to (and does not exclude, restrict, or modify in any way) other rights and remedies under a law to which the Appliances or services relate, including any non-excludable statutory guarantees in Australia and New Zealand.

3. Warranty Period: Subject to these terms and conditions, this warranty continues in Australia for a period of 24 months and in New Zealand for a period of 24 months, following the date of original purchase of the Appliance. Specific components are warranted against manufacturing defects in Australia and New Zealand for the periods listed below;

- Stainless steel box, plates and grills (excludes burners, gas valves and ignitions) – Further 8 years
- Quartz stone & marine grade plywood carcasses – Further 3 years

4. Repair or replace warranty: During the Warranty Period, Electrolux or its ASC will, at no extra charge if your Appliance is readily accessible for service, without special equipment and subject to these terms and conditions, repair or replace any parts which it considers to be defective. Electrolux may, in its absolute discretion, choose whether the remedy offered for a valid warranty claim is repair or replacement. Electrolux or its ASC may use refurbished parts to repair your Appliance. You agree that any replaced Appliances or parts become the property of Electrolux.

5. Travel and transportation costs: Subject to clause 7, Electrolux will bear the reasonable cost of transportation, travel and delivery of the Appliance to and from Electrolux or its ASC. Travel and transportation will be arranged by Electrolux as part of any valid warranty claim.

6. Proof of purchase is required before you can make a claim under this warranty.

7. Exclusions: You may not make a claim under this warranty unless the defect claimed is due to faulty or defective parts or workmanship. This warranty does not cover:

- (a) light globes, batteries, filters or similar perishable parts;

- (b) parts and Appliances not supplied by Electrolux;
- (c) cosmetic damage which does not affect the operation of the Appliance;
- (d) damage to the Appliance caused by:
 - (i) negligence or accident;
 - (ii) misuse or abuse, including failure to properly maintain or service;
 - (iii) improper, negligent or faulty servicing or repair works done by anyone other than an Electrolux authorised repairer or ASC;
 - (iv) normal wear and tear;
 - (v) power surges, electrical storm damage or incorrect power supply;
 - (vi) incomplete or improper installation;
 - (vii) incorrect, improper or inappropriate operation;
 - (viii) insect or vermin infestation;
 - (ix) failure to comply with any additional instructions supplied with the Appliance;

In addition, Electrolux is not liable under this warranty if:

- (a) the Appliance has been, or Electrolux reasonably believes that the Appliance has been, used for purposes other than those for which the Appliance was intended, including where the Appliance has been used for any non-domestic purpose;
- (b) the Appliance is modified without authority from Electrolux in writing;
- (c) the Appliance's serial number or warranty seal has been removed or defaced.

8. How to claim under this warranty: To enquire about claiming under this warranty, please follow these steps:

- (a) carefully check the operating instructions, user manual and the terms of this warranty;
- (b) have the model and serial number of the Appliance available;
- (c) have the proof of purchase (e.g. an invoice) available;
- (d) telephone the numbers shown below.

9. Australia: For Appliances and services provided by Electrolux in Australia: Electrolux goods come with guarantees that cannot be excluded under the Australian Consumer Law. You are entitled to a replacement or refund for a major failure and for compensation for any other reasonably foreseeable loss or damage. You are also entitled to have the Appliance repaired or replaced if the Appliance fails to be of acceptable quality and the failure does not amount to a major failure. 'Acceptable quality' and 'major failure' have the same meaning as referred to in the ACL.

10. New Zealand: For Appliances and services provided by Electrolux in New Zealand, the Appliances come with a guarantee by Electrolux pursuant to the provisions of the Consumer Guarantees Act, the Sale of Goods Act and the Fair Trading Act. Where the Appliance was purchased in New Zealand for commercial purposes the Consumer Guarantee Act does not apply.

11. Confidentiality: You accept that if you make a warranty claim, Electrolux and its agents including ASC may exchange information in relation to you to enable Electrolux to meet its obligations under this warranty.

Important Notice

Before calling for service, please ensure that the steps listed in clause 8 above have been followed.

AUSTRALIA	FOR SERVICE or to find the address of your nearest authorised service centre in Australia PLEASE CALL 1300 307 939 <small>For the cost of a local call</small>	FOR SPARE PARTS or to find the address of your nearest spare parts centre in Australia PLEASE CALL 13 13 50 <small>For the cost of a local call</small>
NEW ZEALAND	FOR SERVICE or to find the address of your nearest authorised service centre in New Zealand PLEASE CALL 0800 10 66 10	FOR SPARE PARTS or to find the address of your nearest spare parts centre in New Zealand PLEASE CALL 0800 10 66 20



Customer Care Centre

Contact us if you need more help

AUSTRALIA

phone: 1300 307 939

email: customercare@beefeaterbbq.com

web: beefeaterbbq.com

NEW ZEALAND

phone: 0800 436 245

email: customercare@electrolux.co.nz

web: beefeaterbbq.com

