

# NAM 60 68 72 H FLAIL MOWER



## Operator's Manual

**MechMaxx**

[www.mechmaxx.com](http://www.mechmaxx.com)





## TABLE OF CONTENTS

|                                     |   |                                    |    |
|-------------------------------------|---|------------------------------------|----|
| <b>TABLE OF CONTENTS</b>            | 1 | <b>OPERATING INSTRUCTIONS</b>      | 8  |
| <b>SPECIFICATIONS</b>               | 2 | TRANSPORTING                       | 8  |
| <b>SAFETY SIGNS</b>                 | 3 | MOWING INSTRUCTIONS                | 8  |
| <b>IMPORTANT SAFETY INFORMATION</b> | 4 | OPERATING INSTRUCTIONS             | 8  |
| SAFETY AT ALL TIMES                 | 4 | <b>ADJUSTMENTS</b>                 | 9  |
| LOOK FOR THE SAFETY ALERT SYMBOL    | 4 | LEVELING THE MOWER                 | 9  |
| BE AWARE OF SIGNAL WORDS            | 4 | CUTTING HEIGHT ADJUSTMENT          | 9  |
| FOR YOUR PROTECTION                 | 4 | 3-POINT HITCH ADJUSTMENTS          | 9  |
| SHUTDOWN AND STORAGE                | 4 | BELT TENSION                       | 9  |
| USE SAFETY LIGHTS AND DEVICES       | 4 | <b>MAINTENANCE AND LUBRICATION</b> | 10 |
| TRANSPORT MACHINERY SAFELY          | 5 | MAINTENANCE                        | 10 |
| KEEP RIDERS OFF MACHINERY           | 5 | KNIFE REPLACEMENT                  | 10 |
| PRACTICE SAFE MAINTENANCE           | 5 | V-BELT INSTALLATION                | 10 |
| PREPARE FOR EMERGENCIES             | 5 | STORAGE                            | 10 |
| WEAR PROTECTIVE EQUIPMENT           | 5 | LUBRICATION                        | 10 |
| AVOID HIGH PRESSURE FLUIDS HAZARD   | 5 | <b>TROUBLESHOOTING</b>             | 12 |
| INTRODUCTION                        | 5 | <b>APPENDIX</b>                    | 13 |
| APPLICATION                         | 5 | BOLT TORQUE                        | 13 |
| USING THIS MANUAL                   | 5 | ENGLISH TORQUE SPECIFICATIONS      | 13 |
| TERMINOLOGY                         | 6 | METRIC TORQUE SPECIFICATIONS       | 14 |
| DEFINITIONS                         | 6 | <b>WARRANTY</b>                    | 15 |
| OWNER ASSISTANCE                    | 6 | <b>PARTS DIAGRAM</b>               | 16 |
| SERIAL NUMBER PLATE                 | 6 | <b>PARTS LIST</b>                  | 17 |
| <b>ASSEMBLY AND SET-UP</b>          | 7 |                                    |    |
| TRACTOR REQUIREMENTS                | 7 |                                    |    |
| ASSEMBLY                            | 7 |                                    |    |
| TRACTOR HOOK-UP                     | 7 |                                    |    |
| DRIVELINE INSTALLATION              | 7 |                                    |    |



## SPECIFICATIONS

| Model                            | NAM60H                    | NAM68H  | NAM72H   |
|----------------------------------|---------------------------|---------|----------|
| Power Required                   | 30-60 hp                  |         | 45-85 hp |
| Working Width                    | 60"                       | 68"     | 72"      |
| Cutting Height Range             | 0.6 – 2"                  |         |          |
| PTO Turning Speed                | 540 rpm                   |         |          |
| PTO Shaft                        | T5-LF-39 , 39.25" / 46.5" |         |          |
| Flail Type                       | Hammer                    |         |          |
| Number of Flails                 | 24                        | 28      |          |
| Roller Diameter                  | 4"                        |         |          |
| Overall Width                    | 66"                       | 75"     | 78"      |
| Rotor Shaft Diameter             | 5"                        |         |          |
| 3PT Center to Center Bottom Pins | 24"                       |         |          |
| 3PT Top Link Pin to Bottom Pins  | 20"                       |         |          |
| Material                         | Steel                     |         |          |
| Side Plate Thickness             | 0.25"                     |         |          |
| Number of Belts                  | 3                         |         |          |
| Blade Swing Diameter             | 14"                       |         |          |
| Slide Distance                   | 16"                       |         |          |
| Finsh                            | Powder Coating            |         |          |
| Product Weight                   | 659 lbs                   | 686 lbs | 701 lbs  |

## SAFETY SIGNS

The rating plate on your machine may show symbols. These represent important information about the product or instructions on its use.

**⚠ DANGER ⚠**



**High Pressure Fluid Hazard.**  
High pressure fluid leak will pierce skin. Release pressure before working on system.  
Detect leaks with wood or cardboard. Wear sturdy gloves and goggles. NEVER use fingers.  
Fluid injected in skin must be surgically removed by trained doctor immediately or gangrene will result.  
Fluid injected into skin will injure or kill.

**⚠ WARNING**

**ENGAGE TRACTOR CLUTCH SLOWLY DURING START UP OR DAMAGE WILL OCCUR. KEEP PTO SHAFT WITH 25° OF LEVEL DURING OPERATION.**

**⚠ WARNING ⚠**

**To Prevent Serious Injury Or Death:**

- Read and understand Operator's manual before using.
- Do not permit riders on the tractor or mower. Never carry child on tractor seat.
- Operate with guards installed and in good condition.
- Operate only with tractor equipped with ROPS and seatbelts.
- Keep away from moving parts.
- Stop engine, set brake and wait for all moving parts to stop before dismounting.
- Be sure lights and reflectors required by law are clean and in good working order before transporting.
- Do not allow children to operate mower.
- Travel with SMV and lights that follow local codes.
- Clean debris from mowing area.
- Do not operate in the raised position.
- Support securely before working beneath unit.
- Review safety instructions annually.

**⚠ WARNING**



**Read and understand operators manual before using this machine.**

**⚠ WARNING**

The PTO Driveline MUST be measured and cut (if required) as per the Owner's Manual. Failure to do so will result in damage to both the tractor and the implement.

**⚠ CAUTION**



**GREASE**

**⚠ DANGER**

**GUARD MISSING WHEN THIS IS VISIBLE DO NOT OPERATE ENTANGLEMENT HAZARD**

**⚠ WARNING**



**BELT DRIVE: HAND AND ARM ENTANGLEMENT HAZARD.**  
Do not open or remove safety shields while engine is running.

**⚠ WARNING**



**PINCH POINT HAZARD**  
Keep clear

**⚠ DANGER ⚠**

**ROTATING KNIVES HAZARD**

To prevent serious injury or death from rotating knives:  
• DO NOT go under frame when rotor is turning or engine is running. Keep others away.  
• Disconnect & lockout power source BEFORE adjusting or servicing.  
• Keep hands, feet, hair, and clothing away from moving parts.

**⚠ WARNING**



**HIGH PRESSURE FLUID HAZARD**  
Relieve pressure before disconnecting lines. Do Not use hands to check for leaks. Consult physician immediately if skin penetration occurs.

**⚠ CAUTION** To avoid Injury or Machine Damage: \*Operate only with 540 rpm PTO

**540 RPM ONLY**

**LIFT POINT**



**⚠ DANGER! STAY BACK 150 FEET AT ALL TIMES**

**⚠ WARNING! DO NOT MOW IN REVERSE OR DAMAGE WILL OCCUR TO YOUR MOWER!**

**⚠ DANGER**



**ROTATING DRIVELINE CONTACT CAN CAUSE DEATH KEEP AWAY! DO NOT OPERATE WITHOUT :**

- All driveline guards, tractor, and equipment shields in place.
- Drivelines securely attached at both ends.
- Driveline guards that turn freely on driveline.

**⚠ DANGER**



**ROTATING BLADES KEEP HANDS AWAY**

**⚠ WARNING**



**FLYING OBJECTS HAZARD**  
Keep clear.

## IMPORTANT SAFETY INFORMATION

### SAFETY AT ALL TIMES

Thoroughly read and understand the instructions given in this manual before operation. Refer to the "Safety Decal", read all instructions noted on them.

Do not allow anyone to operate this equipment who has not fully read and comprehended this manual and who has not been properly trained in the safe operation of the equipment.

- Operator should be familiar with all functions of the unit.
- Operate implement from the driver's seat only.
- Make sure all guards and shields are in place and secured before operating the implement.
- Do not leave tractor or implement unattended with engine running.
- Dismounting from a moving tractor could cause serious injury or death.
- Do not stand between tractors and implement during hitching.
- Keep hands, feet, and clothing away from power-driven parts.
- Wear snug fitting clothing to avoid entanglement with moving parts.
- Watch out for wires, trees, etc., when raising implement. Make sure all persons are clear of working area.
- Turning tractor too tight may cause implement to ride up on wheels. This could result in injury or equipment damage.

### LOOK FOR THE SAFETY ALERT SYMBOL

The SAFETY ALERT SYMBOL indicates there is a potential hazard to personal safety involved and extra safety precaution must be taken. When you see this symbol, be alert and carefully read the message that follows it. In addition to design and configuration of equipment, hazard control and accident prevention are dependent upon the awareness, concern, prudence and proper training of personnel involved in the operation, transport, maintenance and storage of equipment.

### BE AWARE OF SIGNAL WORDS

A signal word designates a degree or level of hazard seriousness. The signal words are:



**DANGER**

**Indicates an imminently hazardous situation which, if not avoided, will result in death or serious injury. This signal word is limited to the most extreme situations, typically for machine components that, for functional purpose, cannot be guarded.**



**WARNING**

**Indicates a potentially hazardous situation which, if not avoided, could result in death or serious injury, and includes hazards that are exposed when guards are removed. It may also be used to alert against unsafe practices.**



**CAUTION**

**Indicates a potentially hazardous situation which, if not avoided, may result in minor or moderate injury. It may also be used to alert against unsafe practices.**

### FOR YOUR PROTECTION

- Thoroughly read and understand the "safety label" section, read all instructions noted on them.

### SHUTDOWN AND STORAGE

- Lower machine to ground, put tractor in park, turn off engine, and remove the ignition key.
- Detach and store implements in a area where children normally do not play. Secure implement by using blocks and supports

### USE SAFETY LIGHTS AND DEVICES

- Slow moving tractors, self-propelled equipment, and towed implements can create a hazard when driven on public roads. They are difficult to see, especially at night.
- Flashing warning lights and turn signals are recommended whenever driving on public roads. Use lights and devices provided with implement.

## TRANSPORT MACHINERY SAFELY

- Comply with state and local laws.
- Maximum transport speed for implement is 20 mph. Do not exceed. Never travel at a speed which does not allow adequate control of steering and stopping. Some rough terrain requires a slower speed.
- Sudden braking can cause a towed load to swerve and upset. Reduce speed if towed load is not equipped with brakes.
- Use the following maximum speed - tow load weight ratios as a guideline:
- 20 mph when weight is less than or equal to the weight of tractor.
- 10 mph when weight is double the weight of tractor.
- **IMPORTANT:** Do not tow a load that is more than double the weight of tractor.

## KEEP RIDERS OFF MACHINERY

- Riders obstruct of operator's view, they could be struck by foreign objects or thrown from the machine.
- Never allow children to operate equipment.

## PRACTICE SAFE MAINTENANCE

- Understand procedure before doing work. Use proper tools and equipment. refer to Operator's Manual for additional information.
- Work in a clean dry area.
- Lower the implement to the ground, put tractor in park, turn off engine, and remove key before performing maintenance.
- Allow implement to cool completely.
- Do not grease or oil implement while it is operation.
- Inspect all parts. Make sure parts are in good condition and installed properly.
- Remove buildup of grease, oil or debris.
- Remove all tools and unused parts from implement before operation.

## PREPARE FOR EMERGENCIES

- Be prepared if a fire starts.
- Keep a fist aid kit and fire extinguisher handy.
- Keep emergency numbers for doctor, ambulance, hospital and fire department near phone.

## WEAR PROTECTIVE EQUIPMENT

- Protective clothing and equipment should be worn.
- Wear clothing and equipment appropriate for the job. Avoid loose fitting clothing.
- Prolonged exposure to loud noise can cause hearing impairment or hearing loss. Wear suitable hearing protection such as earmuffs or earplugs.
- Operating equipment safely requires the full attention of the operator. Avoid wearing radio headphones while operating machinery.

## AVOID HIGH PRESSURE FLUIDS HAZARD

- Escaping fluid under pressure can penetrate the skin causing serious injury.
- Avoid the hazard by relieving pressure before disconnecting hydraulic lines.
- Use a piece of paper or cardboard, not body parts, to check for suspected leaks. Wear protective gloves and safety glasses or goggles when working with hydraulic systems.
- If an accident occurs, see a doctor immediately. Any fluid injected into the skin must be treated within a few hours or gangrene may result.

## INTRODUCTION

welcomes you to the growing family of new product owners. This implement has been designed with care and built by skilled workers using quality materials. Proper assembly, maintenance, and safe operating practices will help you get years of good use from the machine.

## APPLICATION

The Flail Mowers are designed for Category 1 - three point hitch or Quick-Hitch System mounting. These Fixed Bar Flail Mowers are ideal for ripping, leveling, finish grading, and backfilling applications at feedlots, outdoor arenas, building sites, and maintenance operations on farm and ranch lanes or roadways.

## USING THIS MANUAL

- This Operator's Manual is designed to help familiarize you with safety, assembly, operation, adjustments, troubleshooting, and maintenance. Read this manual and follow the recommendations to help ensure safe and efficient operation.
- The information contained within this manual was current at the time of printing. Some parts may change slightly to assure you of the best performance.

- To order a new Operator's or Parts Manual contact us.

## **TERMINOLOGY**

"Right" or "Left" as used in this manual is determined by facing the direction the machine will operate while in use unless otherwise stated.

## **DEFINITIONS**

Note : A special point of information that the operator must be aware of before continuing.

Important : A special point of information related to its preceding topic. The intention is that this information should be read and noted before continuing.

## **OWNER ASSISTANCE**

The parts on your machine have been specially designed and should only be replaced with genuine parts.

## **SERIAL NUMBER PLATE**

For prompt service always use the serial number and model number when ordering parts from your dealer. Be sure to include your serial and model numbers in correspondence also.

## Assembly and Set-up



**THE GEARBOX AND TRANSMISSION ARE SHIPPED WITHOUT OIL.**

**WARNING ADD OIL BEFORE FIRST USE!**

### TRACTOR REQUIREMENTS

This mower is designed with a 3-Point category I hitch. Tractor horse power rating should not exceed 80 PTO horse power.

### ASSEMBLY

Refer to the parts illustration.

### TRACTOR HOOK-UP

1. Be certain that tractor draw bar will not interfere. Move draw bar ahead or remove if required. Draw bar should also be checked for clearance when unit is being raised for the first time.
2. Align lower link arms of tractor to hitch clevises on mower. Insert lower hitch pins into lower ball swivels and attach linch pins.
3. Attach tractor top link to upper floating hitch on mower with pin supplied. Secure with lock pin.
4. Adjust tractor top link in or out to place upper hitch pin vertically above or slightly behind lower hitch pins to allow mower flotation. The mower should be run with the back 15 degrees lower than the front.

### DRIVELINE INSTALLATION

1. Slide driveline end with extended safety cone over splined shaft of gearbox and secure with attaching device.
2. Slide driveline over tractor's splined PTO shaft and secure with locking device of driveline.
3. Driveline should now be moved back and forth to insure that it is secure on the PTO shaft of the tractor and mower gearbox.
4. Attach chain from the driveline shield to one of the upper hitch braces to ensure that the shield does not rotate.
5. Should driveline require shortening:

- a. Hold the half-shafts next to each other in the shortest working position and mark them.
- b. Shorten inner and outer guard tubes equally.
- c. Shorten inner and outer sliding profiles by the same length as the guard tubes.
- d. Proper overlap is a minimum of one-half the length of each tube, with both tubes being of equal length.
- e. Round off all sharp edges and remove burrs. Grease sliding profiles.



**CAUTION**

**Tractors PTO shield and all mower guards must be in place at all times during operation!**

## OPERATING INSTRUCTIONS

### TRANSPORTING

NOTE: Always disengage PTO before raising mower to transport position.

1. When raising the mower to transport position, be sure that driveline does not contact tractor or mower. Adjust and set the tractor's 3-point hitch lift height so that the driveline does not contact mower deck in the fully raised position.
2. Be sure to reduce tractor ground speed when turning, leaving enough clearance so that the mower does not contact obstacles such as buildings, trees or fences.
3. Select a safe ground travel speed when transporting from one area to another. When traveling on roadways, transport in such a way that faster moving vehicles may pass safely.
4. When traveling over rough or hilly terrain, shift tractor to a lower gear.



CAUTION

**When traveling on public roads, whether at night or during the day, use accessory lights and devices for adequate warning to operators of other vehicles. Comply with all Federal, State, and local laws.**

### MOWING INSTRUCTIONS

1. Clear area to be mowed of objects and debris that might be picked up and thrown by the mower blades.
2. Grass is best cut when it is dry. Mowing wet grass can cause plugging resulting in grass clumps behind the mower.
3. Grass should be mowed frequently as shorter clippings deteriorate faster.
4. If mowing extremely tall grass, it is best to raise cutting height and mow the area, then lower cutting height and mow a second time at the desired height.

### OPERATING INSTRUCTIONS

Proper servicing and adjustments are the key to the long life of any machine. With careful and systematic inspection of the mower, costly maintenance, time and repair can be avoided. Before beginning to mow, the following inspection should be performed:

1. Check oil level in gearbox.
2. Check that all plugs in gearbox have been replaced and tightened properly.
3. Be sure all mower knives, bolts and nuts are tight.
4. Be certain all guards and shields are in place and secure.
5. Grease driveline shaft and all other grease fittings.
6. Clear area to be mowed of rocks, branches and other foreign objects.
7. Lower mower to ground. Set tractor throttle at approximately 1/4 open. Engage PTO to start blades rotating.
8. Operate with 540 rpm PTO tractor.
9. At first begin mowing at a slow forward speed and shift up until the desired speed is achieved - maintaining 540 PTO rpm.
10. Mower knives will cut better at a faster blade speed than at reduced throttle.
11. After mowing the first 50 feet, stop and check to see that the mower is adjusted properly.
12. Do not make sharp turns or attempt to back up while mower is on the ground.
13. Do not engage PTO with mower in the fully raised position. Do not engage PTO at full throttle.

## ADJUSTMENTS

### LEVELING THE MOWER

NOTE: Tractor and mowers should be on level ground.

Leveling can be adjusted at the tractor's 3-point arms and center link.

### CUTTING HEIGHT ADJUSTMENT

The machine's cutting height depends upon the position of the rear roller.

1. Remove the bolts that fix the roller on both sides.
2. Lift or lower both sides of roller in equal measurements.
3. Replace bolts and re-tighten.

### 3-POINT HITCH ADJUSTMENTS

The 3-point hitch system on this mower has been designed for front to back flotation when mowing on uneven terrain. Adjust tractor's top center link to place the upper hitch pin vertically above or slightly behind the lower hitch pins. The mower should be run with the back 15 degrees lower than the front.

The hitch can also be adjusted from side to side by turning the adjustment handle. Turn handle until you have achieved your desired location.

2. Excessive tension on the belt may lead to premature failure of belt and drive components.



CAUTION

**Excessive tension on the belt may lead to premature failure of belt and drive components. Excessive tension on the belt may also lead to a safety hazard to the operator or bystanders.**



CAUTION

**Engage parking brake, shut off tractor, remove key and disengage PTO before making any height adjustments!**

### BELT TENSION



CAUTION

**Belt drive system under spring tension; use care to avoid bodily harm!**

The Belt tension should be checked after the first 20 hours of use. And then every 40 hours of use.

1. Tension on the belt can be adjusted with the belt tension bolt. Turn the bolt until desired tension is achieved. When the belt has the correct tension the gearbox should be adjusted so that the gearbox extension is running straight (parallel) with the flail mower. Loosen bolts at the bottom of the gearbox and move gearbox until gearbox extension is running straight.

## MAINTENANCE AND LUBRICATION

### MAINTENANCE

Proper servicing and adjustment is the key to the long life of any farm implement. With careful and systematic inspection, you can avoid costly maintenance, time and repair.



**CAUTION**

**For safety reasons, each maintenance operation must be performed with tractor PTO disengaged, mower lowered completely to ground and tractor engine shut off with ignition key removed.**

**After using the mower for several hours, check all bolts to be sure they are tight and check drive belt tension. Replace any worn, damaged or illegible safety decals by obtaining new decals from dealer.**

### KNIFE REPLACEMENT

**IMPORTANT:** Make sure that the knife is the same length as the others on the mower. This will keep the rotor rotation balanced.

1. Remove bolt and nut.
2. Remove old knife.
3. Install new knife and existing bolt.
4. Secure with nut.

### V-BELT INSTALLATION



**CAUTION**

**Belt drive system under spring tension; use care to avoid bodily harm!**

1. Remove belt guard fender and belt cover.
2. Disengage belt tension by loosening belt tension bolt until belt can be removed.
3. With tension relieved from belt remove old belt from pulleys.
4. Tighten belt tension bolt.
5. Reinstall belt guard and belt guard fender.

### STORAGE

At the end of the working season or when the mower will not be used for a long period, it is good practice to clean off any dirt or grease that may have accumulated on the mower and any of moving parts.

1. Clean as necessary.
2. Check knives for wear and replace if necessary.
3. Inspect mower for loose, damaged or worn parts and adjust or replace as needed.
4. Store unit inside if possible for longer life.
5. Repaint parts where paint is worn or scratched to prevent rust.
6. Replace all damaged or missing decals.

### LUBRICATION

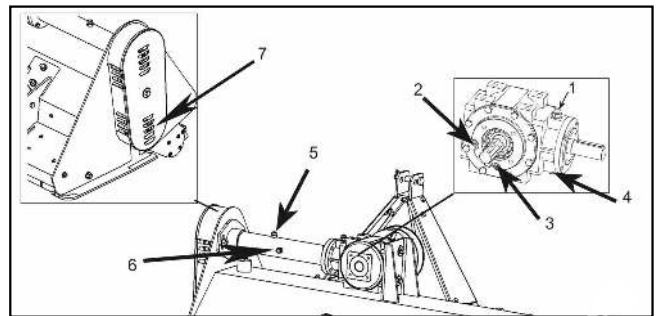

1. Cap for inlet gearbox oil.
2. Cap for gearbox oil level.
3. Cap for discharge gearbox oil.
4. Cap for discharge gearbox oil.
5. Cap for inlet transmission oil.
6. Cap for transmission oil level.
7. Bearing lubricator.

Roller Bearing (Both Ends)



Type of Lubrication: Multipurpose Grease

Driveline Profiles

|   |   |
|---|---|
|  |  <b>20 HOURS</b> |
|---|---|

Type of Lubrication: Multipurpose Grease

Cutter Rotor Bearing (Both Ends)

|   |   |
|---|---|
|  |  <b>25 HOURS</b> |
|---|---|

Type of Lubrication: Multipurpose Grease

Shaft tube

|   |  |
|---|--|
|  |  <b>AS REQUIRED</b> |
|---|--|

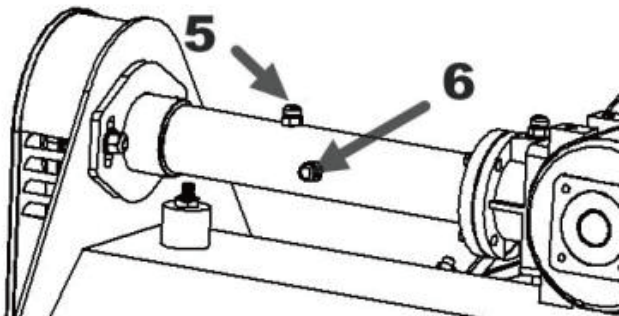

Type of Lubrication: It is advisable to use SAE 85W/140 OIL or equivalent for shaft tube. Correspond to following specifications API - GL5. Oil quantity is 0.35 Lt.

Check oil level in shaft tube by removing the plug (6). Oil should be level with bottom of plug (6) hole. Add oil if necessary by removing top fill plug (5) and side plug (6). Add oil until it flows from side plug (6) hole.

Gearbox

|   |  |
|---|--|
|  |  <b>AS REQUIRED</b> |
|---|--|

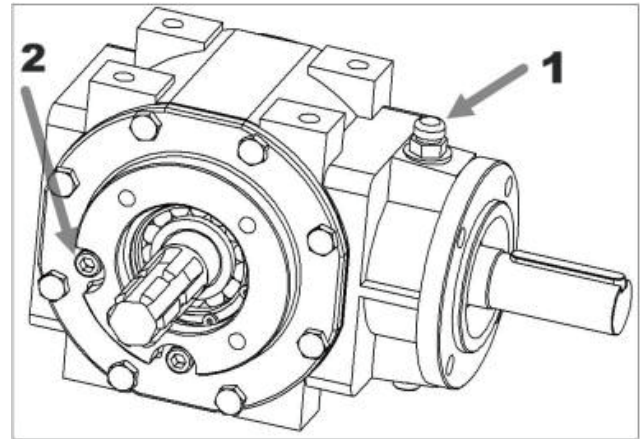

Type of Lubrication: It is advisable to use SAE 85W/140 OIL or equivalent for the overdrive unit. Correspond to following specifications API - GL5. Oil quantity is 1.2 Lt.

Check oil level in gearbox by removing the plug (2) located on the right hand side. Oil should be level with bottom of plug (2) hole. Add oil if necessary by removing top fill plug (1) and side plug (2). Add oil until it flows from side plug (2) hole.

Do not overfill!

**IMPORTANT:** Mower should be level when checking oil in gearbox!

## TROUBLESHOOTING

| Problem   | Solution   |
|---|--|
| <br><b>CAUTION</b> | <b>Do not try to clean rear discharge area when mower is running. Bodily harm may occur!</b> |
| Belt slipping   | Unplug and clean mower deck.   |
|   | Remove belt guard shields and clean sheaves.   |
|   | Replace belt.  |
| Patches of uncut grass  | Mow at full throttle (540 PTO rpm), check PTO speed and tractor engine.                      |
|   | Shift transmission to a lower gear.  |
|   | Tighten belts.   |
|   | Replace missing knives.  |
| Excessive vibration   | Replace knives.  |
|   | Replace drive belt.  |
|   | Replace pulleys or align.  |
|   | Remove belt guard shields & clean debris from belt area & sheaves.                           |
| Gearbox noisy   | Check lubricant level.   |
| Knives scalping grass   | Raise cutting height by adjusting roller.  |
|   | Change mowing pattern.   |
|   | Reduce speed turns.  |
| Uneven cut  | Shift to a lower gear.   |
|   | Level mower.   |
|   | Replace missing knives.  |
| Tractor loaded down by mower  | Mow at full throttle (540 PTO rpm).  |
|   | Shift to a lower gear.   |
|   | Clean mower.   |

## APPENDIX

### Bolt Torque

The tables shown below give correct torque values for various bolts and cap screws. Tighten all bolts to the torques specified unless otherwise noted. Check tightness of bolts periodically, using bolt torque chart as a guide. Replace hardware with the same strength.

### ENGLISH TORQUE SPECIFICATIONS

| Bolt Diameter | Bolt Torque |       |       |       |       |       |
|---------------|-------------|-------|-------|-------|-------|-------|
|               | SAE 2       |       | SAE 5 |       | SAE 8 |       |
|               | N.m         | lb-ft | N.m   | lb-ft | N.m   | lb-ft |
| 1/4"          | 8           | 6     | 12    | 9     | 17    | 12    |
| 5/16"         | 13          | 10    | 25    | 19    | 36    | 27    |
| 3/8"          | 27          | 20    | 45    | 33    | 63    | 45    |
| 7/16"         | 41          | 30    | 72    | 53    | 100   | 75    |
| 1/2"          | 61          | 45    | 110   | 80    | 155   | 115   |
| 9/16"         | 95          | 60    | 155   | 115   | 200   | 165   |
| 5/8"          | 128         | 95    | 215   | 160   | 305   | 220   |
| 3/4"          | 225         | 165   | 390   | 290   | 540   | 400   |
| 7/8"          | 230         | 170   | 570   | 420   | 880   | 650   |



**METRIC TORQUE SPECIFICATIONS**

| Bolt Diameter | Bolt Torque |       |      |       |
|---------------|-------------|-------|------|-------|
|               | 8.8         |       | 10.9 |       |
|               | N.m         | lb-ft | N.m  | lb-ft |
| M3            | 0.5         | 0.4   | 1.8  | 1.3   |
| M4            | 3           | 2.2   | 4.5  | 3.3   |
| M5            | 6           | 4     | 9    | 7     |
| M6            | 10          | 7     | 15   | 11    |
| M8            | 25          | 18    | 35   | 26    |
| M10           | 50          | 37    | 70   | 52    |
| M12           | 90          | 66    | 125  | 92    |
| M14           | 140         | 103   | 200  | 148   |
| M16           | 225         | 166   | 310  | 229   |
| M20           | 435         | 321   | 610  | 450   |
| M24           | 750         | 553   | 1050 | 744   |
| M30           | 1495        | 1103  | 2100 | 1550  |
| M36           | 2600        | 1917  | 3675 | 2710  |

Torque figures indicated above are valid for non-greased or non-oiled threads and heads otherwise specified. Therefore, do not grease or oil bolts or cap screws unless otherwise specified in this manual. When using locking elements, increase torque values by 5%.



---

## WARRANTY

---

We warrants to the original purchaser that this product will be free from defects in material and workmanship beginning on the date of purchase by the end user according to the following schedule when used as intended and under normal service and conditions for personal use.

Overall Unit and Driveline: One year Parts

Gearbox: One year on all components.

Blades and Belts: Considered wear items.

This warranty is limited to the replacement of any defective part by manufacturer, and does not cover common wear items such as blades, belts, tines, etc. We reserves the right to inspect any equipment or parts which are claimed to have been defective in material or workmanship.

This warranty does not apply to any part or product which in judgment shall have been misused or damaged by accident or lack of normal maintenance or care, or which has been repaired or altered in a way which adversely affects its performance or reliability, or which has been used for a purpose for which the product not designed. Misuse also specifically includes failure to properly maintain oil levels, grease points, and driveline shafts.

Claims under this warranty must be made to directly and all warranty adjustments must be made through. We reserves the right to make changes in materials or design of the product at any time without notices. This warranty shall not be interpreted to render We liable for damages of any kind, direct, consequential, or contingent to property. Furthermore, We shall not be liable for damages resulting from any cause beyond its reasonable control. This warranty does not extend to loss of crops, any expense or loss for labor, supplies, rental machinery or for any other reason.

No other warranty of any kind whatsoever, express or implied, is made with respect to this sale; and all implied warranties of merchant-ability and fitness for a particular purpose which exceed the obligations set forth in this written warranty are hereby disclaimed and excluded from this sale.

**PARTS DIAGRAM**

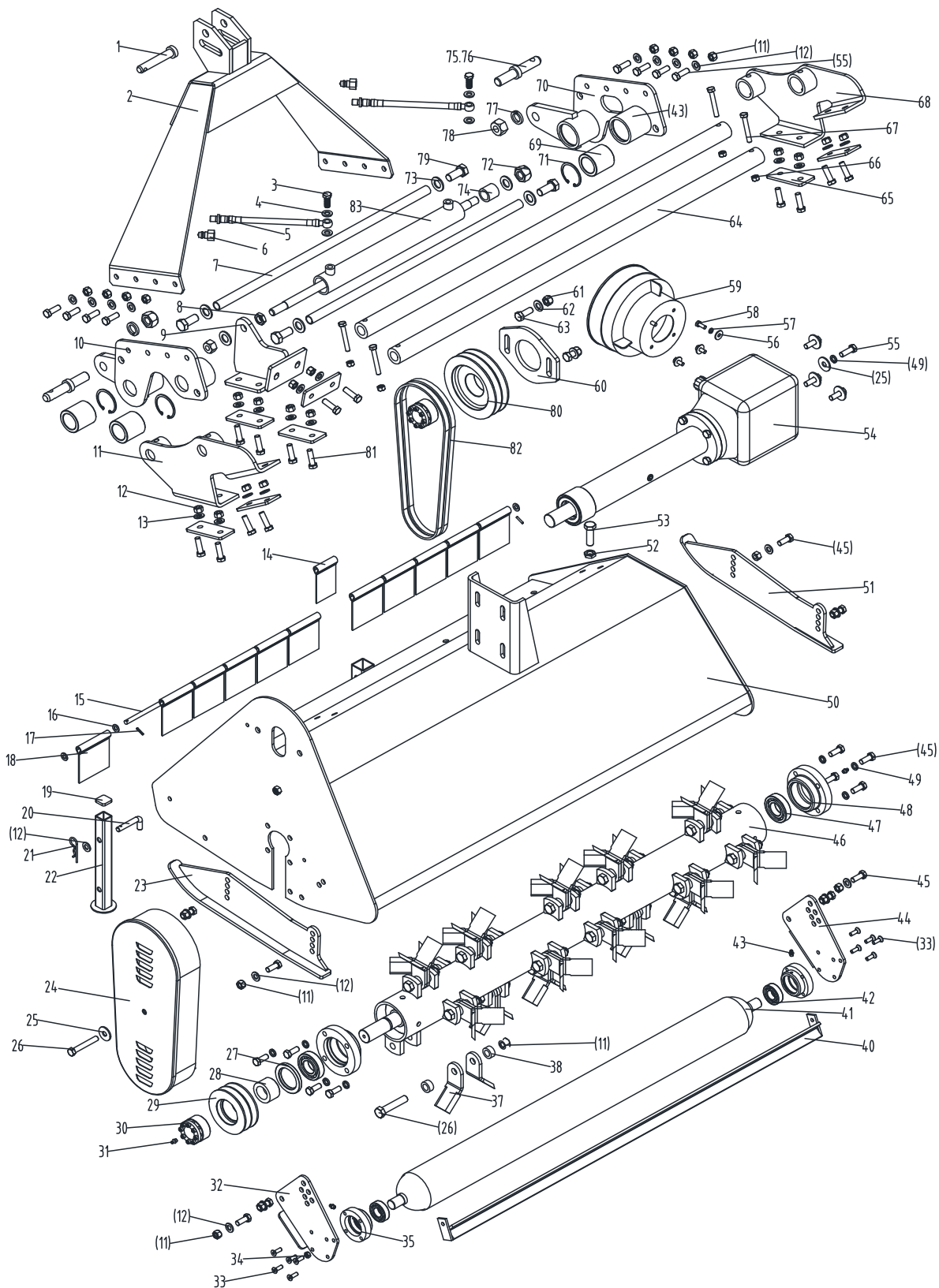

## PARTS LIST

| REF | DESCRIPTION                  | QTY |
|-----|------------------------------|-----|
| 1   | Pin shaft                    | 1   |
| 2   | Hanging weldment             | 1   |
| 3   | Bolt M12X1.25X30             | 2   |
| 4   | Washer 12                    | 4   |
| 5   | Oil pipe                     | 2   |
| 6   | Quick connector R1/2"        | 2   |
| 7   | Supporting tube              | 2   |
| 8   | Nut M18x1.5                  | 1   |
| 9   | Cylinder seat                | 1   |
| 10  | Slippage bracket(R)          | 1   |
| 11  | Connecting bracket(R)        | 1   |
| 12  | Locking nut M12              | 50  |
| 13  | Plain washer 12              | 53  |
| 14  | Fender                       | 1   |
| 15  | Shaft for fender             | 1   |
| 16  | Plain washer 10              | 17  |
| 17  | Elastic cylindrical pin 4x22 | 2   |
| 18  | Fender                       | 12  |
| 19  | Cover                        | 1   |
| 20  | Bent pin                     | 1   |
| 21  | R pin                        | 1   |
| 22  | Supporting frame             | 1   |
| 23  | Base plate (L)               | 1   |
| 24  | Belt cover                   | 1   |
| 25  | Plain washer 12              | 5   |
| 26  | Bolt M12x1.5x80              | 21  |
| 27  | Oil seal FB55X80X8           | 1   |
| 28  | Oil-sealing sleeve           | 1   |
| 29  | Small belt ptlley            | 1   |

| REF | DESCRIPTION               | QTY |
|-----|---------------------------|-----|
| 30  | Swellable sleeve          | 2   |
| 31  | Oil cup M8X1              | 2   |
| 32  | Supporting for roller (R) | 1   |
| 33  | Hex.head bolt M8X25       | 10  |
| 34  | Locking nut M8            | 12  |
| 35  | Bearing                   | 2   |
| 37  | Blade                     | 40  |
| 38  | Sleeve                    | 40  |
| 40  | Mud shield                | 1   |
| 41  | Roller weldment           | 1   |
| 42  | Flange UC205              | 2   |
| 43  | Oil cup M6                | 6   |
| 44  | Supporting for roller (L) | 1   |
| 45  | Bolt M12x30               | 23  |
| 46  | Blade axle weldment       | 1   |
| 47  | Flange UC207-Z            | 2   |
| 48  | Bearing                   | 2   |
| 49  | Spring washer 12          | 12  |
| 50  | The cover weldment        | 1   |
| 51  | Base plate (R)            | 1   |
| 52  | Nut M16x1.5               | 1   |
| 53  | Bolt M16X1.5X50           | 1   |
| 54  | Gearbox assembly          | 1   |
| 55  | Bolt M12x35               | 12  |
| 56  | Plain washer 8            | 4   |
| 57  | Spring washer 8           | 4   |
| 58  | Bolt M8x20                | 4   |
| 59  | Guard shade               | 1   |
| 60  | Tension plate             | 1   |

| REF | DESCRIPTION           | QTY |
|-----|-----------------------|-----|
| 61  | Locking nut M14       | 2   |
| 62  | Plain washer 14       | 2   |
| 63  | Bolt M14x35           | 2   |
| 64  | Guide rail            | 2   |
| 65  | Splint                | 7   |
| 66  | Locking nut M10       | 4   |
| 67  | Bolt M10x70           | 4   |
| 68  | Connecting bracket(L) | 1   |
| 69  | Nylon bush            | 4   |
| 70  | Slippage bracket(L)   | 1   |
| 71  | Circlip 60            | 4   |
| 72  | Locking nut M18X1.5   | 2   |
| 73  | Plain washer 18       | 6   |
| 74  | Sleeve                | 1   |
| 75  | Lockpin               | 2   |
| 76  | Pin for lifting       | 2   |
| 77  | Plain washer 22       | 2   |
| 78  | Locking nut M22X1.5   | 2   |
| 79  | Bolt M18X40           | 4   |
| 80  | Big belt ptlley       | 1   |
| 81  | Bolt M12x40           | 14  |
| 82  | Strap SPB991          | 2   |
| 83  | Slippage cylinder     | 1   |

## GEARBOX ASSEMBLY

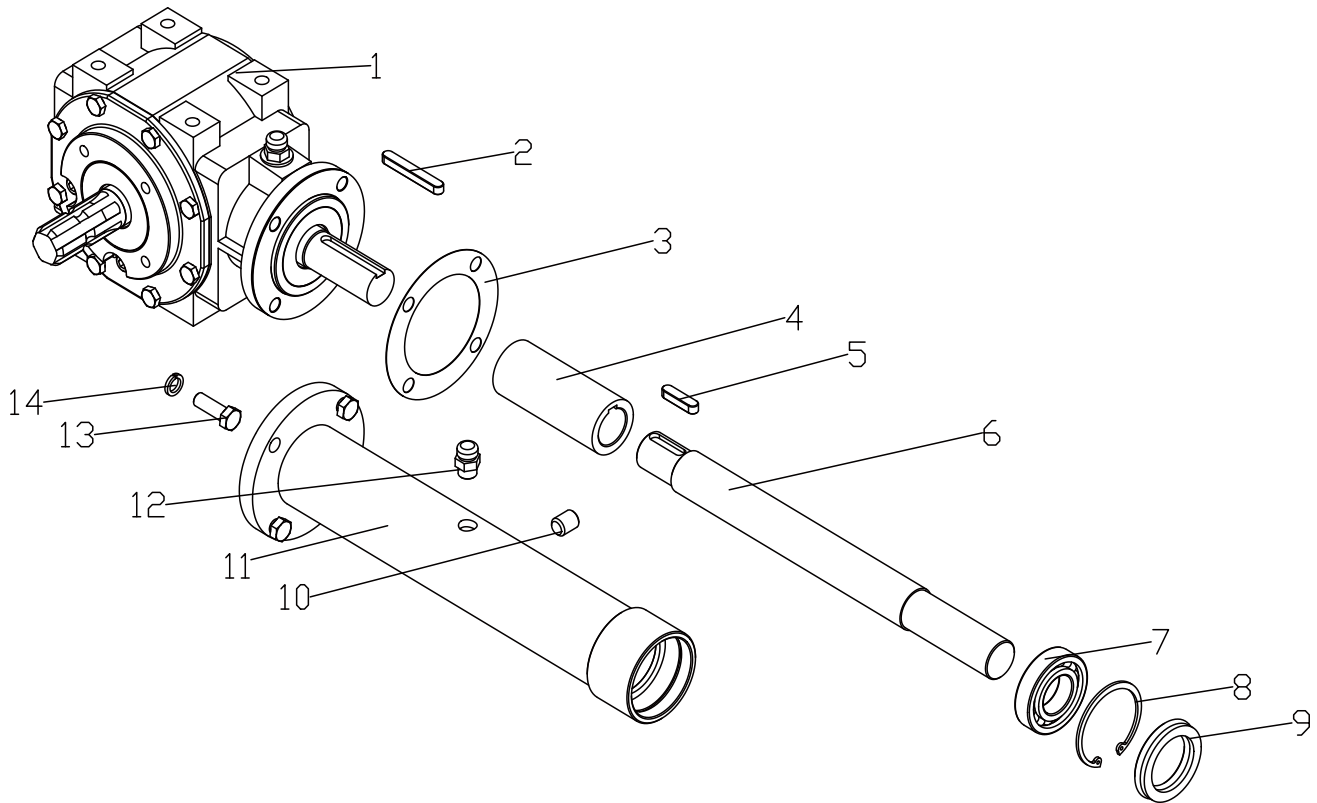

## PARTS LIST

| REF | DESCRIPTION      | QTY |
|-----|------------------|-----|
| 1   | Gearbox assembly | 1   |
| 2   | Key A10X70       | 1   |
| 3   | Paper gasket     | 1   |
| 4   | Connected sleeve | 1   |
| 5   | Key A10X40       | 1   |
| 6   | Shaft            | 1   |
| 7   | Bearing 6207     | 1   |

| REF | DESCRIPTION                  | QTY |
|-----|------------------------------|-----|
| 8   | Circlip 72                   | 1   |
| 9   | Oil seal 35x72x10            | 1   |
| 10  | Retainer                     | 1   |
| 11  | Shaft tube weldment          | 1   |
| 12  | Bolt of plug screw ZG3/8"-19 | 1   |
| 13  | Bolt M12X35                  | 4   |
| 14  | Spring washer 12             | 12  |

## GEARBOX

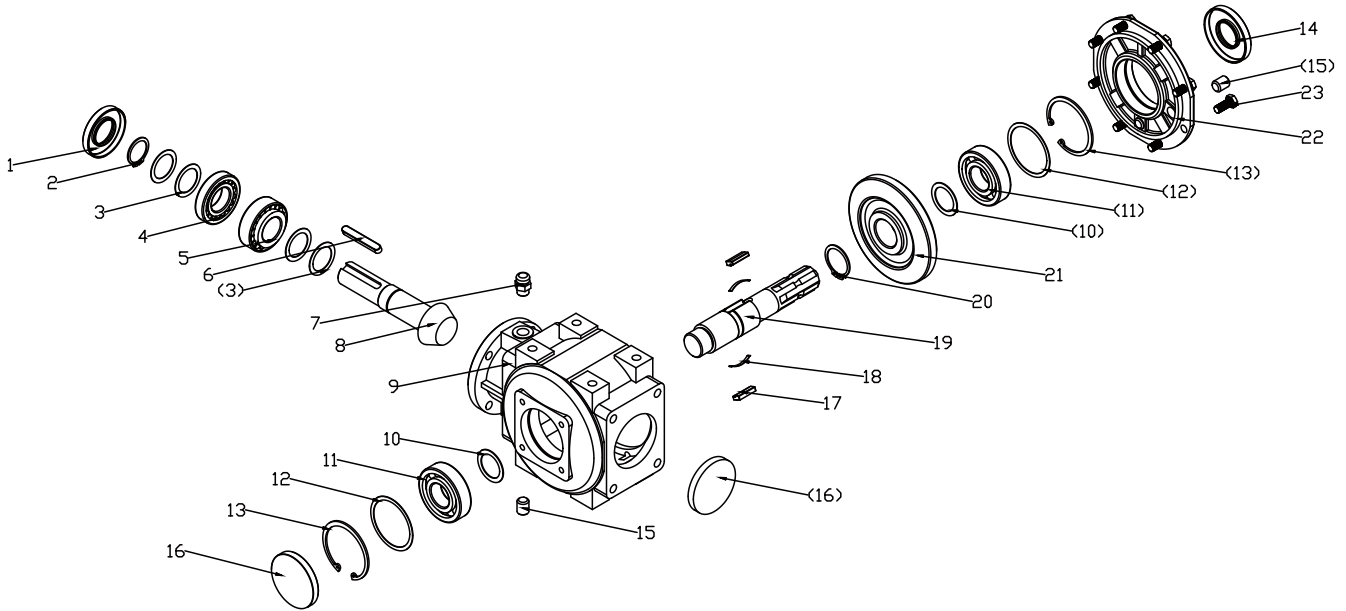

## PARTS LIST

| REF | DESCRIPTION                  | QTY |
|-----|------------------------------|-----|
| 1   | Oil seal 35x72x10            | 1   |
| 2   | Circlips for shaft 35        | 1   |
| 3   | Washer (S) 0.7               | 4   |
| 4   | Bearing 30207                | 1   |
| 5   | Bearing 32207                | 1   |
| 6   | Key 10X65                    | 1   |
| 7   | Bolt of plug screw ZG3/8"-19 | 1   |
| 8   | Bevel gear shaft             | 1   |
| 9   | Gearbox complete             | 1   |
| 10  | Washer (S) 1                 | 2   |
| 11  | Bearing 6307                 | 2   |
| 12  | Washer (B) 0.7               | 2   |

| REF | DESCRIPTION           | QTY |
|-----|-----------------------|-----|
| 13  | Circlips for hole 80  | 2   |
| 14  | Oil seal 35x80x10     | 1   |
| 15  | Retainer              | 1   |
| 16  | Seal cover            | 2   |
| 17  | Key                   | 2   |
| 18  | Spring                | 2   |
| 19  | Pinion shaft          | 1   |
| 20  | Circlips for shaft 42 | 1   |
| 21  | Bevel gear            | 1   |
| 22  | Gearbox cover         | 1   |
| 23  | Bolt M18x40           | 8   |



***MechMaxx***

[info@mechmaxx.com](mailto:info@mechmaxx.com)

