



6+

CONTENTS AND GETTING STARTED

Contents

- 1 Vortex
- 1 Remote Control

Getting Started

The remote control requires 2 AAA 1.5V batteries (not included) and the vehicle requires 4 AA 1.5V batteries (not included).

Vehicle

1. Make sure the power switch on the bottom of the vehicle is in the off position.
2. Use a Phillips-head screwdriver to remove the screw from the battery cover and then remove the battery cover.
3. Insert 4 AA 1.5V batteries (not included) into the battery compartment according to the battery diagram.
4. Replace the battery cover and securely tighten the screw.

Remote control

1. Use a tool to press and hold the battery cover release on the back of the remote control and then slide down the battery cover.
2. Insert 2 AAA 1.5V batteries (not included) into the battery compartment according to the battery diagram.
3. Slide the battery cover back into place securely.

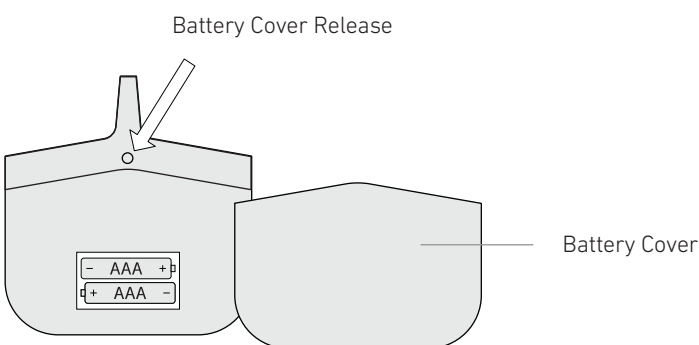
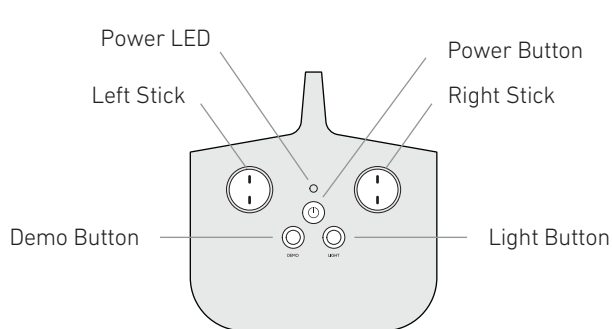
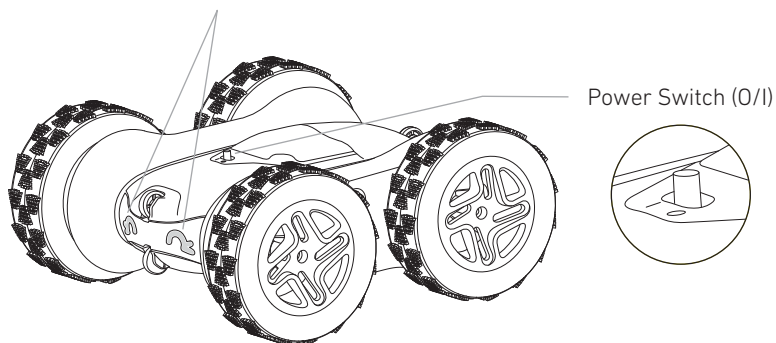
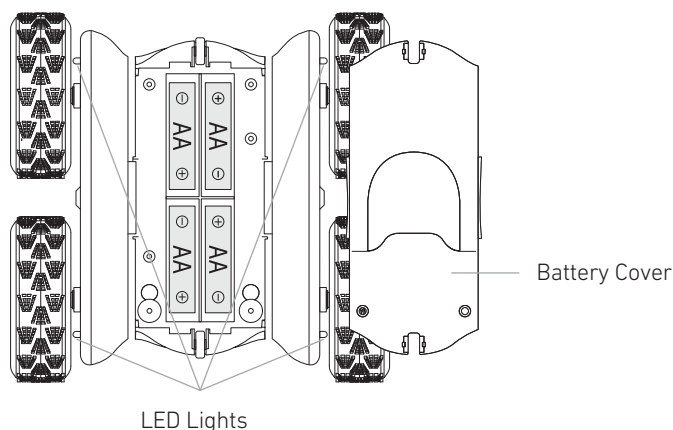

HOW TO PLAY

Power and Pairing

1. Make sure both the remote control and vehicle are powered off.
2. Press the power button on the remote control to power on the remote control. The power light on the remote control will glow white, fading on and off, to indicate the remote control is in pairing mode and ready to pair with the vehicle.
3. Flip the switch on the bottom of the vehicle to the on position to power on the vehicle. The pairing light on the vehicle will glow, fading on and off, to indicate the vehicle is in pairing mode. It will automatically begin pairing with the remote control.
4. Wait for the pairing light on the remote control to quit fading on and off. It will stay solidly lit when pairing is successful.
5. If pairing is unsuccessful within 60 seconds, power off both the remote control and vehicle and then repeat steps 2 through 4.
6. Start driving!
7. If pairing is interrupted or out of range, the remote control and vehicle will both enter pairing mode and attempt to reconnect. Move the remote control and vehicle closer together. If pairing is unsuccessful within 60 seconds, power off both the remote control and vehicle and then repeat steps 2 through 4.
8. When finished driving, press the power button on the remote control to power off the remote control and flip the switch on the bottom of the vehicle to the off position to power off the vehicle.

Note: To save battery life, the remote control and vehicle automatically enter sleep mode after 5 minutes of inactivity. To wake from sleep mode, power off and then power on the remote control and vehicle.

IMPORTANT: If the vehicle stops suddenly while the headlights flash rapidly, power off the vehicle and wait at least 30 minutes for the battery to cool before continuing to drive.

Multiple Drivers

The remote control connects to the vehicle using 2.4GHz digital channel selection that allows up to 16 drivers to race side by side in the same wireless range without interference. Pair each vehicle and remote separately.

6+

HOW TO PLAY

Forward

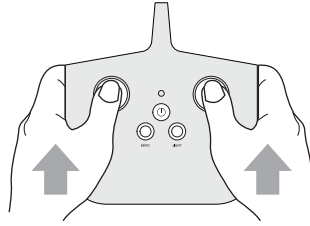
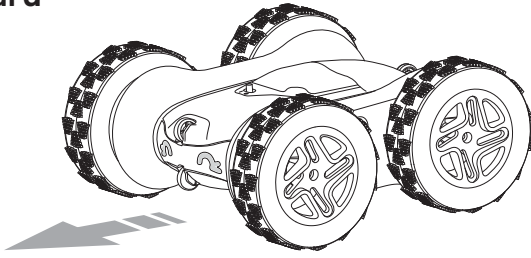

Reverse

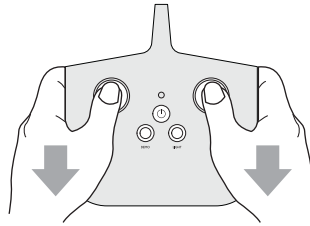
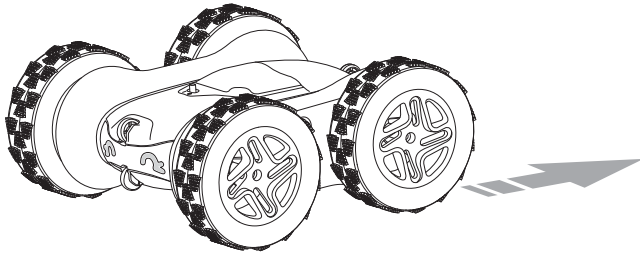

Left Spin

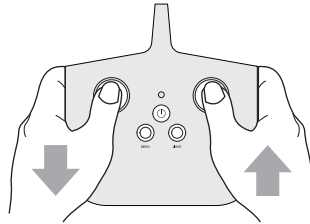
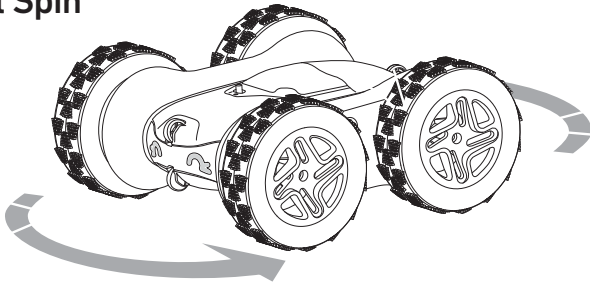

Right Spin

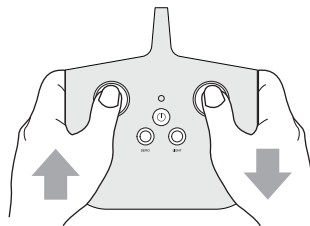
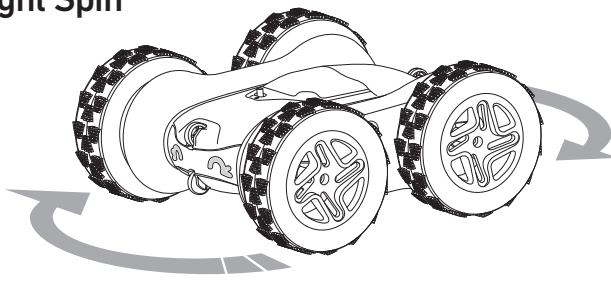

Demo Show

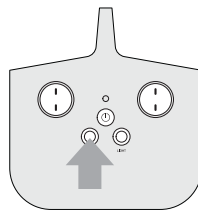
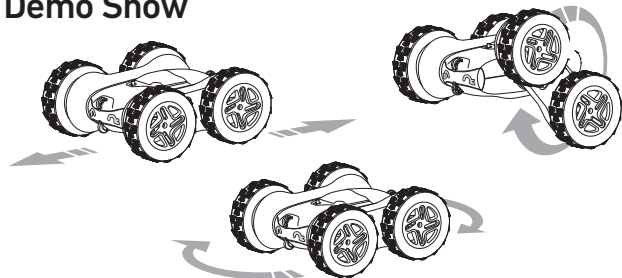

Light Effect

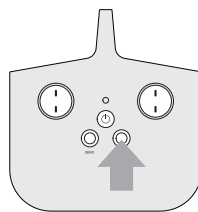
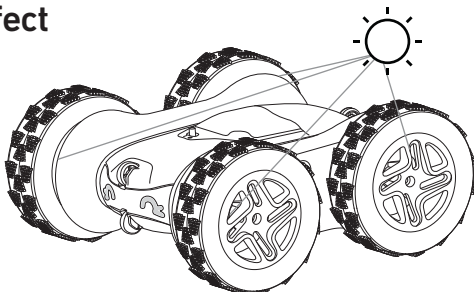

SAFETY PRECAUTIONS

- Adult supervision is recommended when operating the vehicle.
- Always drive responsibly and make sure driving paths are clear. Never drive towards or in close proximity to people or animals. Never drive on streets or roadways to avoid traffic hazards.
- Keep fingers, hair, and loose clothing away from tires and all moving parts while the vehicle is in motion.
- Avoid exposing the vehicle and remote control to water. Avoid driving through water. Never drive outdoors in rain or snow. Never leave the vehicle or remote control outdoors overnight.
- Do not expose the vehicle or remote control to extreme temperatures.
- Do not leave the vehicle or remote control near sources of heat or under direct sunlight for extended periods.
- Do not sit, step, stand, or place objects on the vehicle. It is not designed to support extra weight.
- Do not disassemble or modify the vehicle or remote control.
- Thoroughly inspect the vehicle and remote control before every use. If the vehicle or remote control appears worn, frayed, splintered, cracked, or broken in any manner, discontinue use and discard immediately.

⚠️ ALKALINE BATTERY WARNINGS

- Do not mix old and new batteries.
- Do not mix alkaline, standard (carbon-zinc), or rechargeable batteries.
- Alkaline batteries are recommended. Use only the specified voltage.
- Insert batteries using the correct polarity. Always use, replace, and recharge (if applicable) batteries under adult supervision.
- Do not attempt to charge non-rechargeable batteries.
- Do not short-circuit the battery supply terminals.
- Do not dispose of batteries in fire: batteries may explode or leak.
- Remove batteries before storing.
- Recycle or dispose of batteries according to federal, state, and local laws.
- Keep these instructions for future reference.

This device complies with Part 15 of the FCC Rules. Operation is subject to the following two conditions: (1) this device may not cause harmful interference, and (2) this device must accept any interference received, including interference that may cause undesired operation.

Note: This equipment has been tested and found to comply with the limits for a Class B digital device, pursuant to Part 15 of the FCC Rules. These limits are designed to provide reasonable protection against harmful interference in a residential installation. This equipment generates, uses and can radiate radio frequency energy and, if not installed and used in accordance with the instructions, may cause harmful interference to radio communications. However, there is no guarantee that interference will not occur in a particular installation. If this equipment does cause harmful interference to radio or television reception, which can be determined by turning the equipment off and on, the user is encouraged to try to correct the interference by one or more of the following measures:

- Reorient or relocate the receiving antenna.
- Increase the separation between the equipment and receiver.
- Connect the equipment into an outlet on a circuit different from that to which the receiver is connected.
- Consult the dealer or an experienced radio/TV technician for help.

Warning: Changes or modifications to this unit not expressly approved by the party responsible for compliance could void the user's authority to operate the equipment.

Sharper Image® name and logos (including the 77 logo) are trademarks or registered trademarks. Distributed by and © 2024 MerchSource, LLC, Irvine, CA 92618. All rights reserved.

Model No.: 1019040



WARNING:
CHOKING HAZARD – Small Parts.
Not for children under 3 years of age.

KEEP THIS INSTRUCTION MANUAL AS IT CONTAINS IMPORTANT INFORMATION FOR FUTURE REFERENCE.

Due to continuous product improvements, the pictures on this manual may differ slightly from the actual product.

Printed in China

For customer support, please visit
www.msccustomercaare.com or call

1-800-374-2744