

Use & Care Guide

Manual de Uso y Cuidado

Guide d'utilisation et d'entretien

English / Español / Français

Models/Modelos/Modèles: 253.6000\*, 6002\*, 6008\*, 6030\*, 6040\*, 6041\*,  
6050\*, 7008\*, 7030\*, 7040\*, 7050\*

# Kenmore®

## Top Mount Refrigerator

### Refrigerador Superior

### Réfrigérateur à compartiments superposés

\* = Color number, número de color, le numéro de couleur

P/N A04720801 (1606)

Sears Brands Management Corporation

Hoffman Estates, IL 60179 U.S.A.

[www.kenmore.com](http://www.kenmore.com)

[www.sears.com](http://www.sears.com)

Sears Canada Inc.

Toronto, Ontario, Canada M5B 2C3

[www.sears.ca](http://www.sears.ca)



# Record Model/Serial Numbers

Please read and save these instructions.

This Use & Care Guide provides specific operating instructions for your model. Use your unit only as instructed in this guide. These instructions are not meant to cover every possible condition and situation that may occur. Common sense and caution must be practiced when installing, operating, and maintaining any appliance.

Please record your model and serial numbers below for future reference. This information is found on the serial plate located inside the refrigerator compartment.

Model Number: 253

Serial Number: \_\_\_\_\_

Purchase Date: \_\_\_\_\_

## IMPORTANT

Use only soap and water to clean serial plate.

## Table of Contents

Record Model/Serial Numbers .....	2
Important Safety Instructions.....	2-4
Warranty Information .....	5
Master Protection Agreements .....	6
Features at a Glance .....	7
First Steps .....	8-14
Connecting the Water Supply.....	15
Setting the Temperature Control .....	16-17
Optional Features .....	18-19
Food Storage and	
Energy-Saving Ideas.....	20
Ice Service .....	21
Normal Operating Sounds .....	22
Care & Cleaning .....	23-25
Before You Call .....	26-28

# Important Safety Instructions

## Safety Precautions

Do not attempt to install or operate your unit until you have read the safety precautions in this manual. Safety items throughout this manual are labeled with a Danger, Warning, or Caution based on the risk type.

## Definitions

 This is the safety alert symbol. It is used to alert you to potential personal injury hazards. Obey all safety messages that follow this symbol to avoid possible injury or death.



## DANGER

**DANGER** indicates an imminently hazardous situation which, if not avoided, will result in death or serious injury.



## WARNING

**WARNING** indicates a potentially hazardous situation which, if not avoided, could result in death or serious injury.



## CAUTION

**CAUTION** indicates a potentially hazardous situation which, if not avoided, may result in minor or moderate injury.

## IMPORTANT

Indicates installation, operation, or maintenance information which is important but not hazard-related.

# Important Safety Instructions



## WARNING

Please read all safety instructions before using your new appliance.

- Refrigerants must be evacuated by a licensed, EPA certified refrigerant technician in accordance with established procedures.

## For Your Safety

- Do not store or use gasoline or other flammable liquids in the vicinity of this or any other appliance. Read product labels for warnings regarding flammability and other hazards.
- Do not operate the unit in the presence of explosive fumes.
- Avoid contact with any moving parts of automatic ice maker.
- Remove all staples from the carton. Staples can cause severe cuts and also destroy finishes if they come in contact with other appliances or furniture.

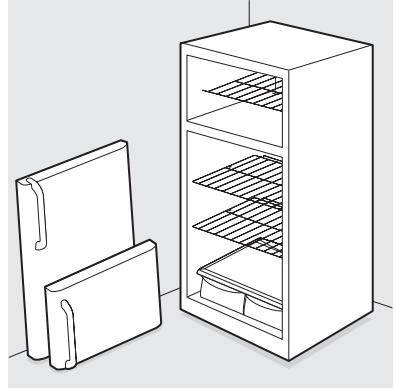

## Child Safety

Destroy or recycle the carton, plastic bags, and any exterior wrapping material immediately after the unit is unpacked. Children should never use these items to play. Cartons covered with rugs, bedspreads, plastic sheets or stretch wrap may become airtight chambers and can quickly cause suffocation.



## WARNING

These guidelines must be followed to ensure that safety mechanisms in this unit will operate properly.

## Proper Disposal of your Appliance

### Risk of child entrapment

Child entrapment and suffocation are not problems of the past. Junked or abandoned appliances are still dangerous – even if they will sit for “just a few days.” If you are getting rid of your appliance, please follow the instructions below to help prevent accidents.

Dispose of refrigerator in accordance with Federal and Local regulations. Before you throw away your old unit:

- Remove doors.
- Leave shelves in place so children may not easily climb inside.

## Electrical Information

- The refrigerator must be plugged into its own dedicated 10 amp, 115 Volt, 60 Hz. AC only electric outlet. The power cord of the appliance is equipped with a three-prong grounding plug for your protection against shock hazards. It must be plugged directly into a properly grounded three-prong receptacle. The receptacle must be installed in accordance with local codes and ordinances. Consult a qualified electrician. Do not use an extension cord or adapter plug.
- Immediately repair or replace any power cord that becomes frayed or damaged.

# Important Safety Instructions

- Never unplug the refrigerator by pulling on the power cord. Always grip the plug firmly, and pull straight out from the receptacle to prevent damaging the power cord.
- Unplug the refrigerator before cleaning and before replacing a light bulb to avoid electrical shock.
- Performance may be affected if the voltage varies by 10% or more. Operating the unit with insufficient power can damage the motor. Such damage is not covered under the warranty. If you suspect your household voltage is high or low, consult your power company for testing.
- Do not plug the unit into an outlet controlled by a wall switch or pull cord to prevent the refrigerator from being turned off accidentally.
- Avoid connecting refrigerator to a Ground Fault Circuit Interruptor (GFCI).

## IMPORTANT

### CFC/HCFC Disposal

Your old refrigerator may have a cooling system that used CFCs or HCFCs (chlorofluorocarbons or hydrochlorofluorocarbons). CFCs and HCFCs are believed to harm stratospheric ozone if released to the atmosphere. Other refrigerants may also cause harm to the environment if released to the atmosphere.

If you are throwing away your old refrigerator, make sure the refrigerant is removed for proper disposal by a qualified technician. If you intentionally release refrigerant, you may be subject to fines and imprisonment under provisions of environmental legislation.

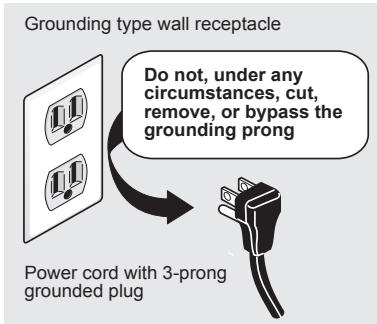

# Warranty Information

## KENMORE LIMITED WARRANTY

FOR ONE YEAR from the date of sale this appliance is warranted against defects in material or workmanship when it is correctly installed, operated and maintained according to all supplied instructions.

WITH PROOF OF SALE, a defective appliance will receive free repair or replacement at option of seller.

For warranty coverage details to obtain free repair or replacement, visit the web page: [www.kenmore.com/warranty](http://www.kenmore.com/warranty)

This warranty applies for only 90 DAYS from the sale date in the United States, and is void in Canada, if this appliance is ever used for other than private household purposes.

This warranty covers ONLY defects in material and workmanship, and will NOT pay for:

1. Expendable items that can wear out from normal use, including but not limited to filters, belts, bags or screw-in base light bulbs.
2. A service technician to clean or maintain this appliance, or to instruct the user in correct appliance installation, operation and maintenance.
3. Service calls to correct appliance installation not performed by Sears authorized service agents, or to repair problems with house fuses, circuit breakers, house wiring, and plumbing or gas supply systems resulting from such installation.
4. Damage to or failure of this appliance resulting from installation not performed by Sears authorized service agents, including installation that was not in accord with electrical, gas or plumbing codes.
5. Damage to or failure of this appliance, including discoloration or surface rust, if it is not correctly operated and maintained according to all supplied instructions.
6. Damage to or failure of this appliance, including discoloration or surface rust, resulting from accident, alteration, abuse, misuse or use for other than its intended purpose.
7. Damage to or failure of this appliance, including discoloration or surface rust, caused by the use of detergents, cleaners, chemicals or utensils other than those recommended in all instructions supplied with the product.
8. Damage to or failure of parts or systems resulting from unauthorized modifications made to this appliance.
9. Service to an appliance if the model and serial plate is missing, altered, or cannot easily be determined to have the appropriate certification logo.

### Disclaimer of implied warranties; limitation of remedies

Customer's sole and exclusive remedy under this limited warranty shall be product repair or replacement as provided herein. Implied warranties, including warranties of merchantability or fitness for a particular purpose, are limited to one year on the appliance and five years on the sealed system, or the shortest period allowed by law. Seller shall not be liable for incidental or consequential damages. Some states and provinces do not allow the exclusion or limitation of incidental or consequential damages, or limitation on the duration of implied warranties of merchantability or fitness, so these exclusions or limitations may not apply to you.

This warranty applies only while this appliance is used in the United States or Canada\*.

This warranty gives you specific legal rights, and you may also have other rights which vary from state to state.

\* In-home repair service is not available in all Canadian geographical areas, nor will this warranty cover user or servicer travel and transportation expenses if this product is located in a remote area (as defined by Sears Canada Inc.) where an authorized servicer is not available.

**Sears Brands Management Corporation, Hoffman Estates, IL 60179**  
**Sears Canada Inc., Toronto, Ontario, Canada M5B 2C3**

# Master Protection Agreements

Congratulations on making a smart purchase. Your new Kenmore® product is designed and manufactured for years of dependable operation. But like all products, it may require preventive maintenance or repair from time to time. That's when having a Master Protection Agreement can save you money and aggravation.

The Master Protection Agreement also helps extend the life of your new product. Here's what the Agreement\* includes:

- ☑ **Parts and labor** not just for repairing defects, but to help keep products operating properly **under normal use**. Our coverage goes **well beyond the product warranty**. No deductibles, no functional failure excluded from coverage— **real protection**.
- ☑ **Expert service** by experienced service technicians trusted in millions of homes every year.
- ☑ **Unlimited service calls and nationwide service**, as often as you want us, whenever you want us.
- ☑ **“No-lemon” guarantee** – replacement of your covered product after three separate product failures occur within twelve months and a fourth repair is required. Includes free delivery and installation, if necessary, of replacement product.
- ☑ **Product replacement** if your covered product can't be fixed.
- ☑ **Annual Preventive Maintenance Check** at your request – no extra charge.
- ☑ **Fast help by phone** – phone support from a service agent on all products to help troubleshoot problems. Think of us as a “talking owner's manual.”
- ☑ **Power surge protection** against electrical damage due to power fluctuations.
- ☑ **\$300 Food Loss Protection** for any food spoilage that is the result of mechanical failure of any covered refrigerator or freezer.
- ☑ **Service Promise: \$50** if first attempt repair of your covered product can't be accomplished and product is not usable while awaiting further repair service.
- ☑ **25% discount** off the regular price of any non-covered repair service and related installed parts.

Once you purchase the Agreement, a simple phone call is all that it takes for you to schedule service. You can call anytime day or night.

The Master Protection Agreement is a risk free purchase. If you cancel for any reason during the product warranty period, we will provide a full refund. Or, a prorated refund anytime after the product warranty period expires. Purchase your Master Protection Agreement today!

**Some limitations and exclusions apply. For prices and additional information in the U.S.A. call 1-800-827-6655.**

**\* Coverage in Canada varies on some items. For full details call Sears Canada at 1-800-361-6665.**

## Sears Installation Service

For Sears professional installation of home appliances, garage door openers, water heaters, and other major home items, in the U.S.A. call 1-844-553-6667, and in Canada call 1-800-469-4663.

# Features At A Glance

Features may vary according to model

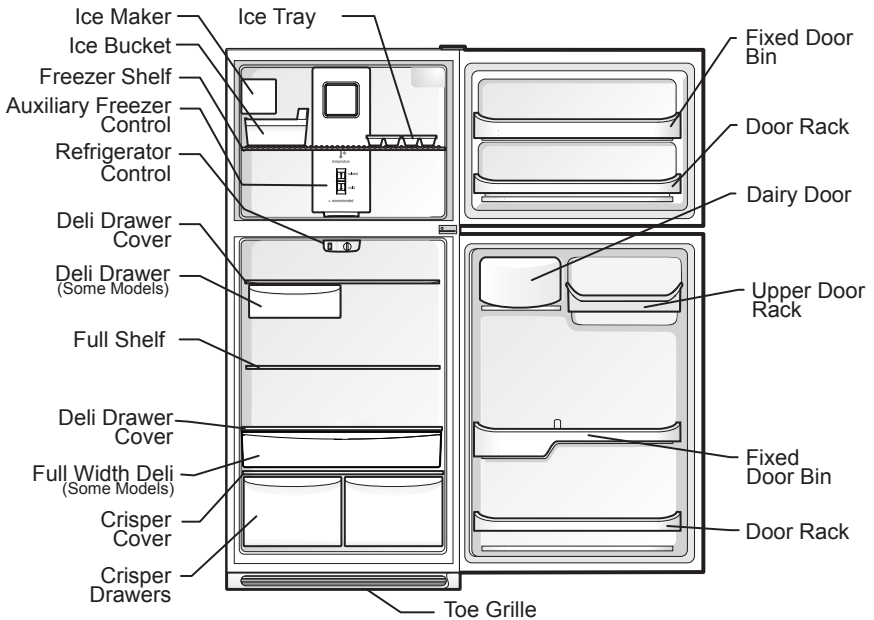

## IMPORTANT

### Cleaning your Refrigerator

Remove tape and glue residue from surfaces before turning on the refrigerator. Rub a small amount of liquid dish soap over the adhesive with your fingers. Rinse with warm water and dry with a soft cloth.

Do not use sharp instruments, rubbing alcohol, flammable fluids, or abrasive cleaners to remove tape or glue. These products can damage the surface of your refrigerator.

After you remove all of the package materials, clean the inside of your refrigerator before using it. See the "Care & Cleaning" section in this manual.

See important information about cleaning glass shelves and covers in the "Optional Features" section of this manual.

## IMPORTANT

### Moving your Refrigerator

Your refrigerator is heavy. When moving the refrigerator for cleaning or service, be sure to cover the floor with cardboard or hardboard to avoid floor damage. Always pull the refrigerator straight out when moving it. Do not wiggle or "walk" the refrigerator when trying to move it as floor damage could occur.

# First Steps

This Use & Care Guide provides general operating instructions for your model. Use the refrigerator only as instructed in this Use & Care Guide. Before starting the refrigerator, follow these important first steps.

## Location

- Choose a place that is near a grounded electrical outlet. Do not use an extension cord or an adapter plug.
- If possible, place the refrigerator out of direct sunlight and away from the range, dishwasher or other heat sources.
- The refrigerator must be installed on a floor that is level and strong enough to support a fully loaded refrigerator.
- Consider water supply availability for models equipped with an automatic ice maker. If you do not hook up water to the refrigerator, remember to turn the ice maker off.



## CAUTION

**Do not install the refrigerator where the temperature will drop below 55°F (13°C) or rise above 110°F (43°C).**

**The compressor will not be able to maintain proper temperatures inside the refrigerator.**

**Do not block the toe grille on the lower front of your refrigerator. Sufficient air circulation is essential for the proper operation of your refrigerator.**

## IMPORTANT

If you install your refrigerator in a garage or other unheated area, you may experience freezer temperature problems during the winter months when temperatures dip below 55°F (13°C).

Upgrading your refrigerator with a Garage Kit will lower the minimum operating temperature of your unit to 34°F (1°C). This kit can be ordered through Sears stores or Sears Parts & Repair at an additional cost (Kit No. 5303918301).

## NOTE

For additional instructions on garage installation, refer to “Setting the Temperature Controls” section.

## Installation

### Installation clearances

- Allow the following clearances for ease of installation, proper air circulation, and plumbing and electrical connections:

Sides & Top	3/8 inch
Back	1 inch

## NOTE

If your refrigerator is placed with the door hinge side against a wall, you may have to allow additional space for the handle so the door can be opened wider.

### Guidelines for final positioning of your refrigerator:

- All four corners of the cabinet must rest firmly on the floor.
- The cabinet should be level at the front and rear.
- The sides should tilt 1/4-inch (6 mm) from front-to-back (to ensure that doors close and seal properly).
- Doors should align with each other and be level.

# First Steps

To level the cabinet using the front rollers:

- 1 Remove the toe grille.

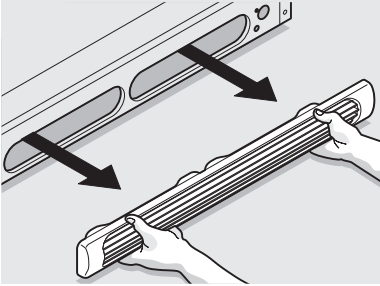

## NOTE

Raise the front of the refrigerator enough so the doors close freely when opened halfway. The refrigerator should slope  $\frac{1}{4}$  inch to  $\frac{1}{2}$  inch from front-to-back. Then level the refrigerator from side-to-side.

- 2 Use a flat-blade screwdriver or  $\frac{3}{8}$  inch socket wrench to raise or lower the front rollers (Figure 2). Do not raise the cabinet more than  $\frac{9}{16}$  inch.

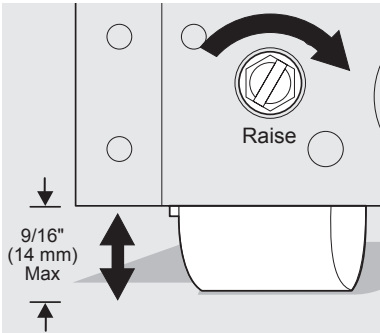

Figure 2

or

- 3 Use adjustable wrench to adjust leveling screws. Lower the leveling screws on each side clockwise until they contact the floor (Figure 3). Do not raise the cabinet more than  $\frac{9}{16}$  inch.

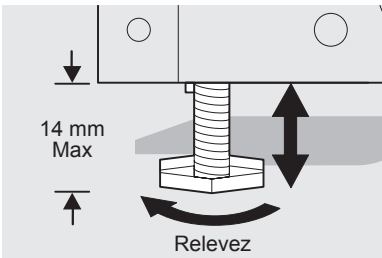
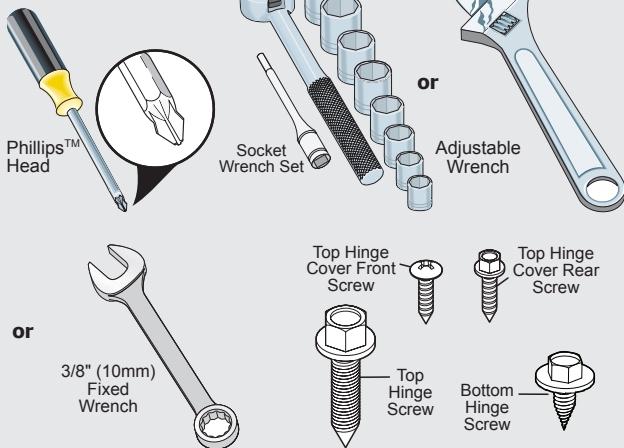

Figure 3

# First Steps

## Tools Necessary:



## NOTE

The direction in which your refrigerator doors open (door swing) can be reversed, from left to right or right to left, by moving the door hinges from one side to the other. Reversing the door swing should be performed by a qualified person.

## IMPORTANT

Before you begin, turn the refrigerator temperature control to "0" and remove the electrical power cord from the wall outlet. Remove any food from door shelves.

## Door removal and reversal instructions:

1. Remove toe grille.
2. Remove top hinge cover. Trace around the hinge with a soft lead pencil. This makes reinstallation easier. Remove top hinge and lift door off center hinge pin. Set door, hinge and hinge screws aside for later reinstallation.

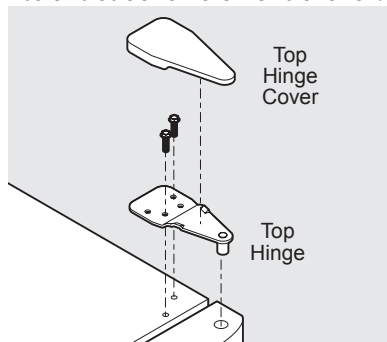

3. Unscrew center hinge pin using adjustable wrench and save for reassembly. Ensure plastic washer stays on hinge pin.
4. Lift refrigerator door off of bottom hinge and set aside.
5. Remove center hinge and shim by removing inside screw and loosening two outside screws enough to allow hinge and shim to slide out. Reinsert inside screw and tighten all three screws.
6. On opposite side of refrigerator, loosen the two outside screws and

remove inside screw. Flip the center hinge and shim over and slide under outside screws. Insert inside screw and tighten all three screws.

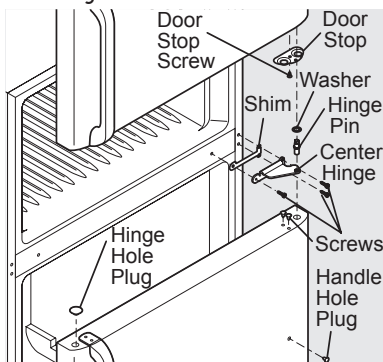

7. Remove three screws from bottom hinge with  $\frac{3}{8}$ " socket wrench.
8. Install bottom hinge on opposite side with the three screws removed in step 7.

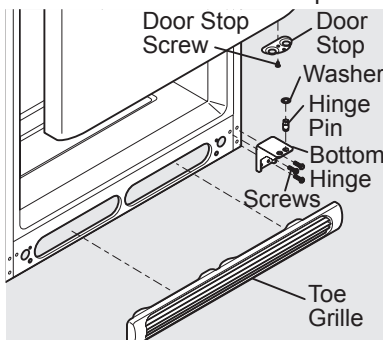

# First Steps

9. Unscrew bottom hinge pin using adjustable wrench. Move hinge pin to other hole in hinge and tighten with adjustable wrench.
10. Reverse door handles (see instruction on next page).
11. Unscrew and move the freezer and refrigerator door stops to the opposite side of the doors. Before inserting screws, use an awl to puncture the door foam.
12. Position refrigerator door onto bottom hinge pin. Remove hinge hole plug from top of door and insert it on opposite side. Screw center hinge pin through center hinge into top of door. Close refrigerator door to help align hinge hole.
13. Tighten center hinge pin with adjustable wrench.
14. Remove top cabinet hole plugs and freezer door hinge hole plug. Insert removed hole plugs into corresponding holes on opposite side of refrigerator. Do not leave open holes.
15. Lower freezer door onto center hinge pin.
16. Close freezer door. Lift up on handle side of door and grasp the thinnest part of the top hinge cover (which was removed in Step 2) and insert the thickest part between the doors on the handle side approximately 3 inches from the outside edge. This will ensure proper spacing when the top hinge screws are tightened.

17. Position top hinge on opposite side of cabinet from which it was removed. Insert top hinge screws and tighten hinge to cabinet. Check door gasket for open seal condition (gap between gasket and cabinet flange). Remove the hinge cover from between the doors and install it back in place over the top hinge.

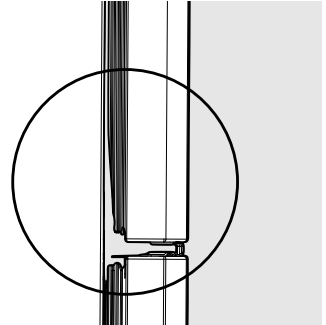

Look for open areas between the gasket and the cabinet flange.

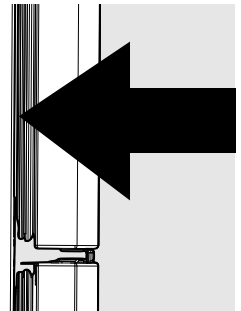

Gasket should seal against the cabinet all the way around including top and bottom

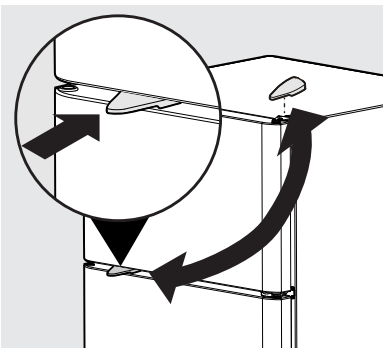

# First Steps

18. Should open seal condition exist, try to massage the gasket to make sure it is seated into the channel.

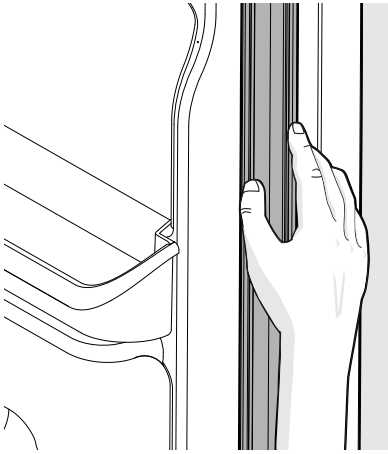

## Handle Installation/Removal

### IMPORTANT

There are instructions for two handle styles on the following pages. To ensure proper installation of both handle styles, review these instructions and pictures thoroughly prior to handle installation.

Additionally, before installing handles, make sure the door swing is correct. See the Door Removal/Reversal instructions in this Use & Care Guide.



### CAUTION

Wear gloves and use extreme CAUTION when installing these handles. The rounded end of the handles may be sharp.



### IMPORTANT

If the condition still exists, try heating the gasket with a hair dryer with the door closed. Use Caution and be careful not to damage the interior door panel or gasket by applying too much heat.

19. If the open seal condition still exists, it may be necessary to flip the gasket. In this case, remove the gasket from the door by pulling it out. Rotate the gasket half a turn (180 degrees). Reinstall the gasket by inserting the corners first then work towards the middle assuring that it is fully seated in the channel.
20. Flip toe grille and reinstall.
21. Plug in electrical power cord and turn refrigerator temperature control to center position. Adjust setting as necessary.

### Handle Style 1 (Plastic Handles)

To attach refrigerator handle:

1. Place bottom of handle over mounting screw and pull up while holding the handle at an angle towards the side of the door.
2. Rotate the handle over the corner of the door until handle is aligned with screw holes on top of door.
3. Secure top of handle with two screws provided.

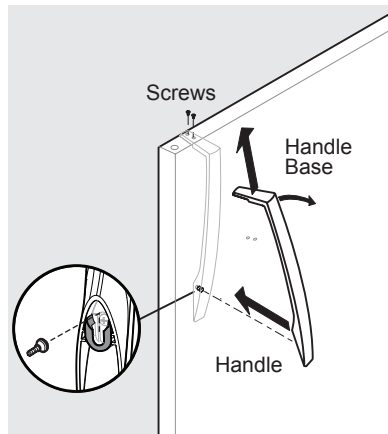

# First Steps

To remove refrigerator handle:

1. Remove two screws attaching handle to top of refrigerator door.
2. Rotate handle towards the side of the door and push down to release it from the mounting screw.
3. Remove mounting screw from door and install on other side, moving hole plugs from corresponding holes to opposite side.

## Handle Style 1 (Plastic Handles)

To attach freezer handle:

1. Place top of handle over mounting screw and pull down while holding the handle at an angle towards the side of the door.
2. Rotate handle over the corner of the door until handle is aligned with screw holes on bottom of door.
3. Secure bottom of handle with two screws provided.

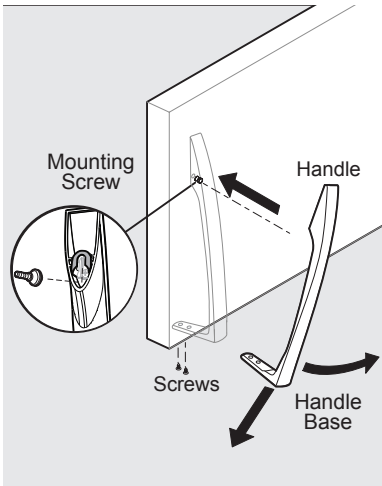

To remove freezer handle:

1. Remove two screws attaching handle to bottom of freezer door.
2. Rotate handle towards the side of the door and push up to release it from the mounting screw.
3. Remove mounting screw from door and install on other side, moving hole plugs from corresponding holes to opposite side.
4. Self-Adhesive Nameplate Models: Use plastic putty knife to gently peel off nameplate from door and reapply over old holes.

To reverse refrigerator/freezer handles:

Handles may be easier to reverse while doors are off.

Reverse freezer and refrigerator handles by inverting the handle removed from the refrigerator door and attaching to the freezer door. Invert the handle removed from freezer door and attach to the refrigerator door.

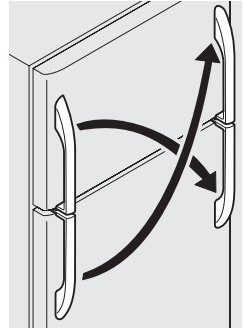

# First Steps

## Handle Style 2 (Metal Handles)

### To attach refrigerator metal handle:

1. Place rounded part of handle onto mounting screw on face of door and align the 2 holes in top of handle with the 2 holes in top of door. Handle should be mounted with set screw facing towards center of door. Do not tighten the set screw yet.
2. Install the 2 screws into the top of the handle.
3. Tighten the set screw on the rounded part of the handle until the handle is flush with the door, and then tighten another  $\frac{1}{2}$  turn.

### To remove refrigerator metal handle:

1. Loosen the set screw on the rounded part of the handle.
2. Remove the 2 screws from the top of the handle.
3. Remove rounded part of handle from mounting screw on face of door.

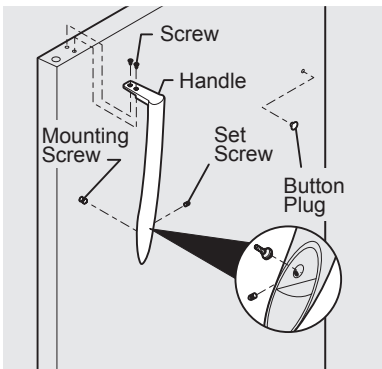

### To attach freezer handle:

1. Place rounded part of handle onto mounting screw on face of door and align the 2 holes in bottom of handle with the 2 holes in bottom of door. Handle should be mounted with set screw facing towards center of door. Do not tighten the set screw yet.

2. Install the 2 screws into the bottom of the handle.
3. Tighten the set screw on the rounded part of the handle until the handle is flush with the door, and then tighten another  $\frac{1}{2}$  turn.

### To remove freezer handle:

1. Loosen the set screw on the rounded part of the handle.
2. Remove the 2 screws from the bottom of the handle.
3. Remove rounded part of handle from mounting screw on face of door.

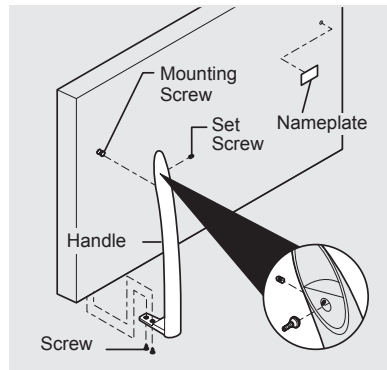

### To reverse refrigerator/freezer handles:

Handles may be easier to reverse while doors are off.

Reverse freezer and refrigerator handles by inverting the handle removed from the refrigerator door and attaching to the freezer door. Invert the handle removed from freezer door and attach to the refrigerator door.

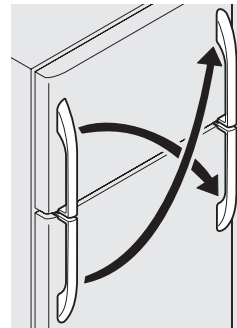

# Connecting Household Water Supply To Refrigerator



## WARNING

To avoid electric shock, which can cause death or severe personal injury, disconnect the refrigerator from electrical power before connecting a water supply line to the refrigerator.



## CAUTION

To Avoid Property Damage:

- Copper tubing is recommended for the water supply line. Water supply tubing made of 1/4" plastic is not recommended since it greatly increases the potential for water leaks. Manufacturer nor retailer will be responsible for any damage if plastic tubing is used for supply line.
- DO NOT install water supply tubing in areas where temperatures fall below freezing.
- Chemicals from a malfunctioning softener can damage the ice maker. If the ice maker is connected to soft water, ensure that the softener is maintained and working properly.

## IMPORTANT

Ensure that your water supply line connections comply with all local plumbing codes.

Before installing the water supply line, you will need:

- Basic Tools: adjustable wrench, flat-blade screwdriver, and Phillips screwdriver
- Access to a household cold water line with water pressure between 30 and 100 psi.
- A water supply line made of 1/4" (6.4 mm) OD, copper tubing. To determine the length of copper tubing needed, you will need to measure the distance from the ice maker inlet valve at the back of the refrigerator to your cold water pipe. Then add approximately 7 feet (2.1 meters), so the refrigerator can be moved out for cleaning (as shown).
- A shutoff valve to connect the water supply line to your household water system. **DO NOT** use a self-piercing type shutoff valve.
- Do not re-use compression fitting or use thread seal tape.
- A compression nut and ferrule (sleeve) for connecting the water supply line to the ice maker inlet valve.

## NOTE

A water line kit is available from Sears stores or Sears Parts & Repair at an additional cost.

## NOTE

These instructions do not cover after market installation. Instructions in after market ice maker kit should be used.

To Connect Water Supply Line To Ice Maker Inlet Valve:

1. Disconnect refrigerator from electric power source.
2. Place end of water supply line into sink or bucket. Turn ON water supply and flush supply line until water is clear. Turn OFF water supply at shutoff valve.
3. Unscrew plastic cap from water valve inlet and discard cap.
4. Slide brass compression nut, and then ferrule (sleeve) onto water supply line, as shown.
5. Push water supply line into water valve inlet as far as it will go (1/4"). Slide ferrule (sleeve) into valve inlet and finger tighten compression nut onto valve. Tighten another half turn with a wrench; **DO NOT** overtighten.
6. With steel clamp and screw, secure water supply line to rear panel of refrigerator as shown.
7. Coil excess water supply line (about 2 1/2 turns) behind refrigerator as shown and arrange coils so they do not vibrate or wear against any other surface.
8. Turn ON water supply at shutoff valve and tighten any connections that leak.
9. Reconnect refrigerator to electrical power source.
10. To turn ice maker on, lower wire signal arm (see ice maker front cover for ON/OFF position of arm).

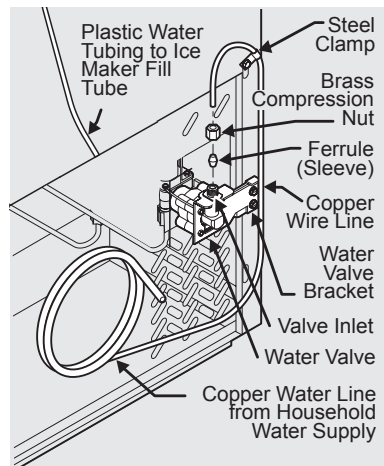

(Include enough tubing in loop to allow moving refrigerator out for cleaning.)

# Setting the Temperature Controls

## Cool Down Period

To ensure safe food storage, allow the refrigerator to operate with the doors closed for at least 8 hours before loading it with food.

## Refrigerator & Freezer Controls (some models)

### NOTE

When first turning refrigerator on, adjust the refrigerator control to recommended. This is the recommended initial setting. After 24 hours, adjust the controls as needed.

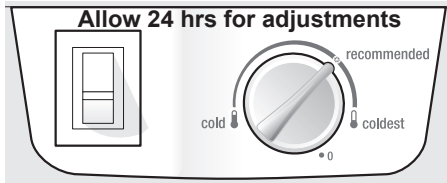

Refrigerator Control

### IMPORTANT

Adjusting the refrigerator temperature control to "0" turns off the compressor and prevents the refrigerator from cooling, but does not disconnect the power to the light bulb and other electrical components. To turn off power to your refrigerator, you must unplug the power cord from the wall outlet.

## Temperature Adjustment

- Adjust temperature gradually: adjust the knob in small increments, allowing the temperature to stabilize.
- For colder temperatures, adjust the knob towards **coldest**.
- For warmer temperatures, adjust the knob towards **cold**.

Adjusting the refrigerator control will change temperatures in both compartments. The auxiliary freezer control can be left at the factory pre-set (Mid Position) or adjusted as desired; it has no effect on electrical power to the refrigerator.

To maintain temperatures, a fan circulates air in the refrigerator and freezer compartments. For good circulation, do not block cold air vents with food items.

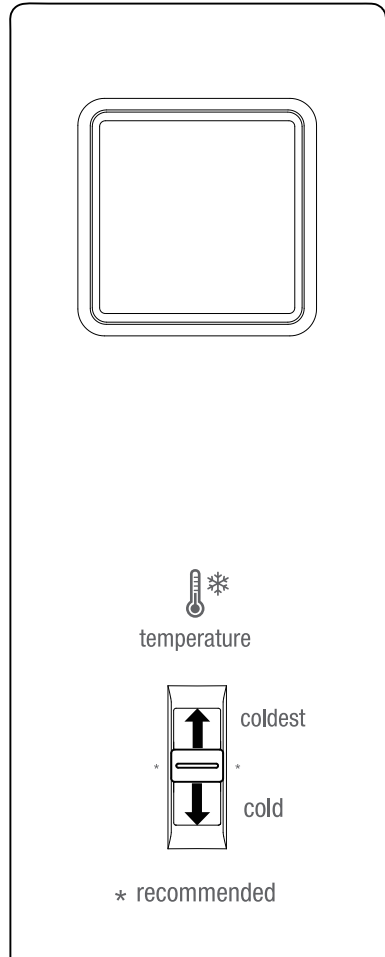

Auxiliary Freezer Control

# Setting the Temperature Controls



## CAUTION

Do not install the refrigerator where the temperature will drop below 55°F (13°C) or rise above 110°F (43°C). The compressor will not be able to maintain proper temperatures inside the refrigerator.

## IMPORTANT

If you install your refrigerator in a garage or other unheated area, you may experience freezer temperature problems during the winter months when temperatures dip below 55°F (13°C).

Upgrading your refrigerator with a Garage Kit will lower the minimum operating temperature of your unit to 34°F (1°C). This kit can be ordered through Sears stores or Sears Parts & Repair at an additional cost (Kit No. 530391830).

# Optional Features



## CAUTION

Do not clean glass shelves or covers with warm water when they are cold. Shelves and covers may break if exposed to sudden temperature changes or impact, such as bumping. Tempered glass is designed to shatter into many small, pebble-size pieces. This is normal. Glass shelves and covers are heavy. Use both hands when removing them to avoid dropping.

## Shelf Adjustment

Refrigerator shelves are easily adjusted to suit individual needs. Before adjusting the shelves, remove all food.

To adjust sliding shelves:

1. Remove shelf by pulling forward to stop position.
2. Lift front edge up and pull out.

To replace shelf, rest side edges on any pair of shelf rails and carefully push shelf back into position.

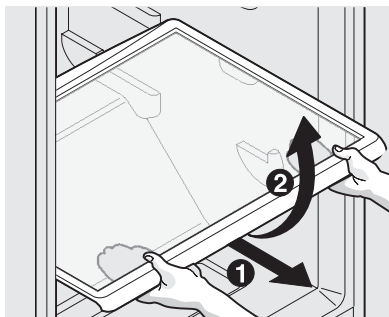

Sliding Glass Shelf

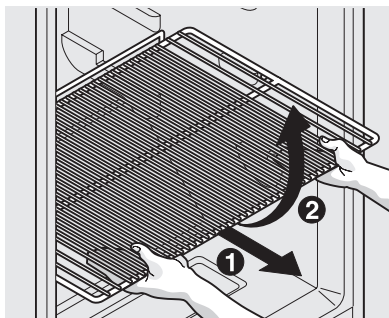

Sliding Wire Shelf

## Door storage

Door bins, shelves, and racks are provided for convenient storage of jars, bottles, and cans. Frequently used items can be quickly selected.

The dairy compartment, which is warmer than the general food storage section, is intended for short term storage of cheese, spreads, or butter.

## Door rack

Some models have door racks or bins that can accommodate gallon-sized plastic drink containers and economy-sized jars and containers.

To remove door rack:

1. Push on rack sides to release from locking tabs.
2. Pull straight out.

To install door rack:

1. Push rack straight ahead.
2. You will hear the sides lock into the tabs.

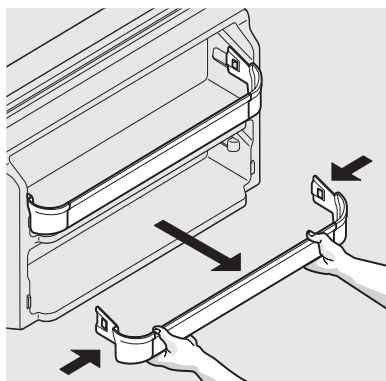

Door Rack

# Optional Features

## Crisper Humidity Control (some models)

The crisper humidity control, present on the crisper drawers of some models, allows you to adjust the humidity within the crisper. This can extend the life of fresh vegetables that keep best in high humidity.

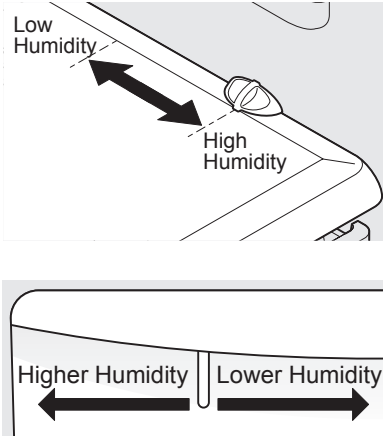

## Crispers (some models)

The crispers, located under the bottom refrigerator shelf, are designed for storing fruits, vegetables, and other fresh produce. Wash items in clear water and remove excess water before placing them in the crispers. Items with strong odors or high moisture content should be wrapped before storing.

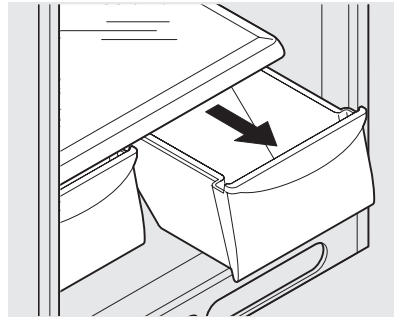

### NOTE

Leafy vegetables keep best when stored with the Humidity Control set on High Humidity, or in a drawer without a Humidity Control. This keeps incoming air to a minimum and maintains maximum moisture content. Store non-leafy vegetables and fruits still in their skins at the low humidity setting.

# Food Storage & Energy Saving Ideas

## Food storage Ideas

### Fresh Food Storage

- The fresh food compartment should be kept between 34°F and 40°F with an optimum temperature of 37°F.
- Avoid overcrowding the refrigerator shelves. This reduces the circulation of air around the food and results in uneven cooling.

### Fruits and Vegetables

- Storage in the crisper drawers helps preserve the fruit and vegetable quality for longer time periods.

### Meat

- Raw meat and poultry should be wrapped securely so leakage and contamination of other foods or surfaces does not occur.

### Frozen Food Storage

- The freezer compartment should be kept at 0°F or lower.
- A freezer operates most efficiently when it is at least  $\frac{2}{3}$  full.

### Packaging Foods for Freezing

- To minimize dehydration and quality deterioration, use aluminum foil, freezer wrap, freezer bags or airtight containers. Force as much air out of the packages as possible and seal them tightly. Trapped air can cause food to dry out, change color, and develop an off flavor (freezer burn).
- Wrap fresh meats and poultry with suitable freezer wrap prior to freezing.
- Do not refreeze meat that has completely thawed.

### Loading the Freezer

- Avoid adding too much warm food to the freezer at one time. This overloads the freezer, slows the rate of freezing, and can raise the temperature of frozen foods.

- Leave a space between the packages, so cold air can circulate freely, allowing food to freeze as quickly as possible.
- Avoid storing hard-to-freeze foods such as ice cream and orange juice on the freezer door shelves. These foods are best stored in the freezer interior where the temperature varies less.

## Energy saving ideas

- Locate the refrigerator in the coolest part of the room, out of direct sunlight, and away from heating products or registers.



- Do not place the refrigerator next to heat-producing appliances such as a range, oven, or dishwasher. If this is not possible, a section of cabinetry or an added layer of insulation between the two appliances will help the refrigerator operate more efficiently.
- Level the refrigerator so that the doors close tightly.
  - Refer to this Use & Care Manual for the suggested temperature control settings.
  - Periodic cleaning of the condenser will help the refrigerator run more efficiently. See the Care and Cleaning Chart.
  - Do not overcrowd the refrigerator or block cold air vents located at upper rear of refrigerator compartment. Doing so causes the refrigerator to run longer and use more energy.
  - Cover foods and wipe containers dry before placing them in the refrigerator. This cuts down on moisture build-up inside the unit.
  - Organize the refrigerator to reduce door openings. Remove as many items as needed at one time and close the door as soon as possible.

# Ice Service

If your refrigerator has an automatic ice maker, it will provide a sufficient supply of ice for normal use. During the initial startup of your refrigerator, however, no ice will be produced during the first 24 hours of operation. Air in new plumbing lines may cause the ice maker to cycle two or three times before making a full tray of ice. With no usage, it will take approximately one to two days to fill the ice container.

New plumbing connections may cause the first production of ice cubes to be discolored or have an odd flavor. Discard ice made during the first 24 hours.

## NOTE

Automatic ice makers are also optional accessories that may be installed in most models at any time.

**Call 1-844-553-6667 for information.**

## Turning your ice maker on

After the plumbing connections have been completed, the water supply valve must be opened. Place the ice container under the ice maker, pushing it as far back as possible. Lower the wire signal arm to its “down” or ON position.

## Turning your ice maker off

To stop the ice maker, lift the wire signal arm until it clicks and locks in the “up” or OFF position. The ice maker

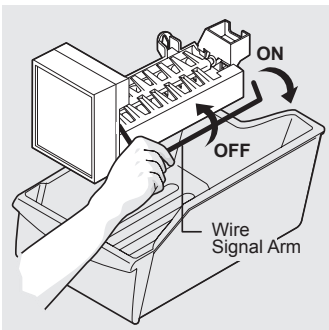

also turns off automatically when the ice container is full. If your model has an adjustable freezer shelf, place the shelf in the lower position, so that the wire signal arm will hit the ice when the container is full.

## IMPORTANT

Your ice maker is shipped from the factory with the wire signal arm in the ON position. To ensure proper function of your ice maker, hook up water supply immediately or turn ice maker OFF by lifting the wire signal arm until it clicks and locks in the UP position. If the ice maker is not turned off and the water supply is not connected, the water valve will make a loud chattering noise.

## Ice Production: What To Expect

The ice maker will produce 2 to 3 pounds of ice every 24 hours depending on usage conditions. Ice is produced at a rate of 8 cubes every 75 to 160 minutes.



## CAUTION

**Chemicals from a malfunctioning softener can damage the ice maker. If the ice maker is connected to soft water, ensure that the softener is maintained and working properly.**

## Ice Maker Tips

- Ice cubes stored too long may develop an odd flavor. Empty the ice container and ensure that the wire signal arm is in its “down” or ON position. The ice maker will then produce more ice.
- Occasionally shake the ice container to keep ice separated.
- Stop the ice maker when cleaning the freezer and during vacations.
- If the ice maker will be turned off for a long period of time, turn the water supply valve to a closed position.

## NOTE

For information on ice maker noises, see **Normal Operating Sounds** section.



## CAUTION

**DO NOT place the ice container in your dishwasher.**

- Wash the ice container in warm water with mild detergent. Rinse well and dry.

# Normal Operating Sounds

## Understanding the sounds you may hear

Your new, high-efficiency refrigerator may introduce unfamiliar sounds. These sounds normally indicate your refrigerator is operating correctly. Some surfaces on floors, walls, and kitchen cabinets may make these sounds more noticeable.

### NOTE

Rigid foam insulation is very energy efficient, but is not a sound insulator.

Following is a list of major components in your refrigerator and the sounds they can cause:

- A **Evaporator** Refrigerant through the evaporator may create a boiling or gurgling sound.
- B **Evaporator fan** You may hear air being forced through the refrigerator by the evaporator fan.
- C **Defrost heater** During defrost cycles, water dripping onto the defrost heater may cause a hissing or sizzling sound. After defrosting, a popping sound may occur.

### IMPORTANT

During the automatic defrost cycle, you may notice a red glow in the vents on the back wall of your freezer compartment. This is normal during the defrost cycle.

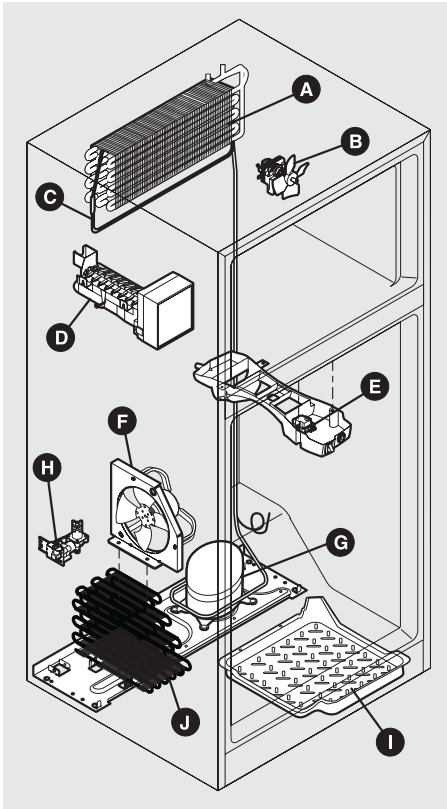

- D **Automatic ice maker** When ice has been produced, you will hear ice cubes falling into the ice bin.
- E **Automatic defrost control** These parts can produce a snapping or clicking sound when turning the cooling system on and off. Control box may differ from the one shown.
- F **Condenser fan** You may hear air being forced through the condenser.
- G **Compressor** Modern, high-efficiency compressors run much faster than in the past. The compressor may have a high-pitched hum or pulsating sound.
- H **Water valve** If your refrigerator is equipped with an automatic ice maker, you will hear a buzzing sound as the water valve opens to fill the ice maker during each cycle.
- I **Drain pan** (not removable) You may hear water dripping into the drain pan during the defrost cycle.
- J **Condenser** May create minimal sounds from forced air.

# Care & Cleaning

## Protecting Your investment

Keeping your refrigerator clean maintains appearance and prevents odor build-up. Wipe up any spills immediately and clean the freezer and fresh food compartments at least twice a year. When cleaning, take the following precautions:

- Never use CHLORIDE or cleaners with bleach to clean stainless steel.
- Do not wash any removable parts in a dishwasher.
- Always unplug the electrical power cord from the wall outlet before cleaning.
- Remove adhesive labels by hand. Do not use razor blades or other sharp instruments which can scratch the appliance surface.
- Do not remove the serial plate.

Do not use abrasive cleaners such as window sprays, scouring cleansers, brushes, flammable fluids, cleaning waxes, concentrated detergents, bleaches or cleansers containing petroleum products on plastic parts, interior doors, gaskets or cabinet liners. Do not use paper towels, metallic scouring pads, or other abrasive cleaning materials or strong alkaline solutions.

## IMPORTANT

If you store or move your refrigerator in freezing temperatures, be sure to completely drain the water supply system. Failure to do so could result in water leaks when the refrigerator is put back into service. Contact a service representative to perform this operation.

## NOTE

If you set your temperature controls to turn off cooling, power to lights and other electrical components will continue until you unplug the power cord from the wall outlet.



## CAUTION

**Pull the refrigerator straight out to move it. Shifting it from side to side may damage flooring. Be careful not to move the refrigerator beyond the plumbing connections.**

**Damp objects stick to cold metal surfaces. Do not touch refrigerated surfaces with wet or damp hands.**

# Care & Cleaning

Care & Cleaning Tips		
Part	What To Use	Tips and Precautions
Interior & Door Liners	<ul style="list-style-type: none"> <li>• Soap and water</li> <li>• Baking soda and water</li> </ul>	Use 2 tablespoons of baking soda in 1 quart of warm water. Be sure to wring excess water out of sponge or cloth before cleaning around controls, light bulb or any electrical part.
Door Gaskets	<ul style="list-style-type: none"> <li>• Soap and water</li> </ul>	Wipe gaskets with a clean soft cloth.
Drawers & Bins	<ul style="list-style-type: none"> <li>• Soap and water</li> </ul>	Use a soft cloth to clean drawer runners and tracks.
Glass Shelves	<ul style="list-style-type: none"> <li>• Soap and water</li> <li>• Glass cleaner</li> <li>• Mild liquid sprays</li> </ul>	Allow glass to warm to room temperature before immersing in warm water.
Toe Grille	<ul style="list-style-type: none"> <li>• Soap and water</li> <li>• Mild liquid sprays</li> <li>• Vacuum attachment</li> </ul>	Vacuum dust from front of toe grille. Remove toe grille (see Installation Instructions). Vacuum backside, wipe with sudsy cloth or sponge. Rinse and dry.
Exterior & Handles	<ul style="list-style-type: none"> <li>• Soap and water</li> <li>• Non Abrasive Glass Cleaner</li> </ul>	Do not use commercial household cleaners containing ammonia, bleach or alcohol to clean handles. Use a soft cloth to clean smooth handles. DO NOT use a dry cloth to clean smooth doors.
Exterior & Handles (Stainless Steel Models Only)	<ul style="list-style-type: none"> <li>• Soap and water</li> <li>• Stainless Steel Cleaners</li> </ul>	<p>Never use CHLORIDE or cleaners with bleach to clean stainless steel.</p> <p>Clean stainless steel front and handles with non-abrasive soapy water and a dishcloth. Rinse with clean water and a soft cloth. Use a non-abrasive stainless steel cleaner. These cleaners can be purchased at most home improvement or major department stores. Always follow manufacturer's instructions. Do not use household cleaners containing ammonia or bleach.</p> <p>NOTE: Always clean, wipe and dry with the grain to prevent scratching. Wash the rest of the cabinet with warm water and mild liquid detergent. Rinse well, and wipe dry with a clean soft cloth.</p>
Replacing Light Bulbs	<ul style="list-style-type: none"> <li>• Unplug refrigerator</li> <li>• Wear gloves</li> <li>• Remove light cover (some models)</li> <li>• Replace old bulb</li> <li>• Replace light cover (some models)</li> <li>• Plug in the refrigerator</li> </ul>	<b>CAUTION:</b> Wear gloves when replacing light bulbs to avoid getting cut. Use same wattage when replacing bulb

# Care & Cleaning

<b>Vacation and Moving Tips</b>	
Short Vacations	<ul style="list-style-type: none"><li>• Leave refrigerator operating during vacations of 3 weeks or less.</li><li>• Use all perishable items from refrigerator compartment.</li><li>• Turn automatic ice maker off and empty ice bucket, even if you will only be gone for a few days.</li></ul>
Long Vacations	<ul style="list-style-type: none"><li>• Remove all food and ice if you will be gone one month or more.</li><li>• Turn off automatic ice maker and turn water supply valve to closed position.</li><li>• Turning control knobs to “0” on the refrigerator (fresh food) control box only controls your refrigerator’s cooling system. To turn off power to your refrigerator you must unplug the power cord from the wall outlet.</li><li>• Clean interior thoroughly.</li><li>• Leave both doors open to prevent odors and mold build-up. Block doors open if necessary.</li></ul>
Moving	<ul style="list-style-type: none"><li>• Remove all food and ice.</li><li>• If using handcart, load from side.</li><li>• Adjust rollers all the way up to protect them during sliding or moving.</li><li>• Pad cabinet exterior to avoid scratching surface.</li></ul>

## Never Clean Condenser (some models)

If your refrigerator is equipped with a “Never Clean” condenser, there’s no need to clean the condenser under normal operating conditions. If the refrigerator is operated under particularly dusty or greasy conditions, or if there is significant pet traffic in your home, it may be necessary to periodically clean the condenser for maximum efficiency.

# Before You Call

TROUBLESHOOTING GUIDE	Before calling for service, review this list. It may save you time and expense. This list includes common occurrences that are not the result of defective workmanship or materials in this appliance.	
PROBLEM	CAUSE	CORRECTION
<b>AUTOMATIC ICE MAKER (some models)</b>		
Ice maker is not making any ice.	<ul style="list-style-type: none"> <li>• Ice maker wire signal arm is in the “up” or OFF position.</li> <li>• Household water line valve is not open.</li> <li>• Freezer is not cold enough.</li> <li>• Saddle valve on cold water pipe is clogged or restricted by foreign material.</li> </ul>	<ul style="list-style-type: none"> <li>• Move wire signal arm to the “down” or ON position (side mounted).</li> <li>• Turn on household water line valve.</li> <li>• See PROBLEM column TEMPERATURES ARE TOO WARM.</li> <li>• Turn off household water line valve. Remove valve. Ensure that valve is not a self-piercing saddle valve. Clean valve. Replace valve if necessary.</li> </ul>
Ice maker is not making enough ice.	<ul style="list-style-type: none"> <li>• Ice maker is producing less ice than you expect.</li> <li>• Freezer is not cold enough.</li> <li>• Household water line valve is not completely open.</li> </ul>	<ul style="list-style-type: none"> <li>• The ice maker will produce 2 to 3 pounds of ice every 24 hours depending on usage conditions. Ice is produced at a rate of 8 cubes every 75 to 160 minutes.</li> <li>• See PROBLEM column TEMPERATURES ARE TOO WARM.</li> <li>• Turn on household water line valve.</li> </ul>
Ice maker will not stop making ice.	<ul style="list-style-type: none"> <li>• Ice maker wire signal arm is being held down by some item in the freezer.</li> </ul>	<ul style="list-style-type: none"> <li>• Move item and release wire signal arm. Remove any ice cubes that are frozen together over the wire signal arm.</li> </ul>
Ice cubes are freezing together.	<ul style="list-style-type: none"> <li>• Ice cubes are not being used frequently enough.</li> <li>• Freezer control is set too warm.</li> <li>• Very little food in freezer.</li> </ul>	<ul style="list-style-type: none"> <li>• Remove ice container and discard ice from container. Ice maker will produce fresh supply.</li> <li>• Set freezer control to colder setting. Allow 24 hours for temperature to stabilize.</li> <li>• Add more food to freezer.</li> </ul>
Ice has bad odor and taste.	<ul style="list-style-type: none"> <li>• Ice has picked up odor or flavor from strong food stored in refrigerator or freezer.</li> <li>• Water running to ice maker has poor taste or odor.</li> <li>• Ice not used frequently enough.</li> </ul>	<ul style="list-style-type: none"> <li>• Cover foods tightly. Discard stale ice. Ice maker will produce fresh supply. Replace air filter (available in select models).</li> <li>• Add filter to water supply line. Consult a water purifying company.</li> <li>• Discard stale ice.</li> </ul>
<b>LIGHT BULB IS NOT ON</b>		
Light bulb is not on.	<ul style="list-style-type: none"> <li>• Light bulb is burned out.</li> <li>• No electric current is reaching refrigerator.</li> </ul>	<ul style="list-style-type: none"> <li>• See Replacing Light Bulbs in NORMAL OPERATING SOUNDS section.</li> <li>• See PROBLEM column RUNNING OF REFRIGERATOR.</li> </ul>

# Before You Call

PROBLEM	CAUSE	CORRECTION
<b>ODORS IN REFRIGERATOR</b>		
Interior is dirty.	<ul style="list-style-type: none"> <li>• Interior needs to be cleaned.</li> <li>• Food with strong odors is in refrigerator.</li> </ul>	<ul style="list-style-type: none"> <li>• See table of Care and Cleaning Tips in CARE &amp; CLEANING section.</li> <li>• Cover food tightly.</li> </ul>
<b>OPENING/CLOSING OF DOORS/DRAWERS</b>		
Door(s) will not close.	<ul style="list-style-type: none"> <li>• Door was closed too hard, causing other door to open slightly.</li> <li>• Refrigerator is not level. It rocks on the floor when moved slightly.</li> </ul>	<ul style="list-style-type: none"> <li>• Close both doors gently.</li> <li>• Ensure floor is level and solid, and can adequately support the refrigerator. Contact a carpenter to correct a sagging or sloping floor.</li> </ul>
Drawers are difficult to move.	<ul style="list-style-type: none"> <li>• Food is touching shelf on top of drawer.</li> <li>• Track that drawers slide on is dirty.</li> </ul>	<ul style="list-style-type: none"> <li>• Remove top layer of items in drawer.</li> <li>• Ensure drawer is properly installed on track.</li> <li>• Clean drawer, rollers, and track. See table of Care and Cleaning Tips in CARE &amp; CLEANING section.</li> </ul>
<b>RUNNING OF REFRIGERATOR</b>		
Compressor and/or fan does not run.	<ul style="list-style-type: none"> <li>• Refrigerator is in defrost cycle.</li> <li>• Plug at electrical outlet is disconnected.</li> <li>• House fuse blown or tripped circuit breaker.</li> <li>• Power outage.</li> </ul>	<ul style="list-style-type: none"> <li>• This is normal for a fully automatic defrost refrigerator. The defrost cycle occurs periodically, lasting about 30 minutes.</li> <li>• Ensure plug is tightly pushed into outlet.</li> <li>• Check/replace fuse with a 15 amp time-delay fuse. Reset circuit breaker.</li> <li>• Check house lights. Call local electric company.</li> </ul>
Refrigerator runs too much or too long.	<ul style="list-style-type: none"> <li>• Room or outside weather is hot.</li> <li>• Refrigerator has recently been disconnected for a period of time.</li> <li>• Automatic ice maker is operating.</li> <li>• Doors are opened too frequently or too long.</li> <li>• Fresh Food/freezer door may be slightly open.</li> <li>• Fresh Food/freezer gasket is dirty, worn, cracked, or poorly fitted.</li> </ul>	<ul style="list-style-type: none"> <li>• It is normal for the refrigerator to work longer under these conditions.</li> <li>• It takes 8-12 hours for the refrigerator to cool down completely.</li> <li>• Ice maker operation causes refrigerator to run slightly more.</li> <li>• Warm air entering the refrigerator causes it to run more. Open doors less often.</li> <li>• Ensure refrigerator is level. Keep food and containers from blocking door. See PROBLEM column OPENING/CLOSING OF DOORS/DRAWERS.</li> <li>• Clean or change gasket. Leaks in door seal will cause refrigerator to run longer in order to maintain desired temperatures.</li> </ul>
Compressor goes off and on frequently.	<ul style="list-style-type: none"> <li>• Thermostat keeps the refrigerator at a constant temperature.</li> </ul>	<ul style="list-style-type: none"> <li>• This is normal. Refrigerator goes on and off to keep temperature constant.</li> </ul>

# Before You Call

PROBLEM	CAUSE	CORRECTION
<b>TEMPERATURE TOO COLD IN REFRIGERATOR (FRESH FOOD) OR FREEZER</b>		
Freezer temperature too cold. Fresh Food temperature is satisfactory.	<ul style="list-style-type: none"> <li>Freezer control is set too cold.</li> </ul>	<ul style="list-style-type: none"> <li>Set freezer control to a warmer setting. Allow 24 hours for temperature to stabilize.</li> </ul>
Fresh Food temperature too cold. Freezer temperature is satisfactory.	<ul style="list-style-type: none"> <li>Fresh Food control is set too cold.</li> </ul>	<ul style="list-style-type: none"> <li>Set fresh food control to a warmer setting. Allow 24 hours for temperature to stabilize.</li> </ul>
Food stored in drawers freezes.	<ul style="list-style-type: none"> <li>Fresh Food control is set too cold.</li> </ul>	<ul style="list-style-type: none"> <li>See solution above.</li> </ul>
<b>TEMPERATURE TOO WARM IN REFRIGERATOR (FRESH FOOD) OR FREEZER</b>		
Freezer/Fresh Food temperature is too warm.	<ul style="list-style-type: none"> <li>Doors are opened too frequently or too long.</li> <li>Door is slightly open.</li> </ul>	<ul style="list-style-type: none"> <li>Warm air enters the refrigerator whenever the door is opened. Open the door less often.</li> <li>See PROBLEM column OPENING/CLOSING OF DOORS/DRAWERS.</li> </ul>
Freezer temperature is too warm. Fresh Food temperature is satisfactory.	<ul style="list-style-type: none"> <li>Freezer control is set too warm.</li> </ul>	<ul style="list-style-type: none"> <li>Set freezer control to a colder setting. Allow 24 hours for temperature to stabilize.</li> </ul>
Fresh Food temperature is too warm. Freezer temperature is satisfactory.	<ul style="list-style-type: none"> <li>Fresh Food control is set too warm.</li> </ul>	<ul style="list-style-type: none"> <li>Set Fresh Food control to a colder setting. Allow 24 hours for temperature to stabilize.</li> </ul>
<b>WATER/MOISTURE/FROST INSIDE REFRIGERATOR</b>		
Moisture collects on inside of refrigerator walls.	<ul style="list-style-type: none"> <li>Weather is hot and humid.</li> <li>Door is slightly open.</li> <li>Door is opened too often or too long.</li> <li>Open containers.</li> </ul>	<ul style="list-style-type: none"> <li>The rate of frost buildup and internal sweating increases.</li> <li>See PROBLEM column OPENING/CLOSING OF DOORS/DRAWERS.</li> <li>Open door less often.</li> <li>Keep containers covered.</li> </ul>
Water collects on bottom side of drawer cover.	<ul style="list-style-type: none"> <li>Vegetables contain and give off moisture.</li> </ul>	<ul style="list-style-type: none"> <li>It is not unusual to have moisture on the bottom side of the cover.</li> <li>Move humidity control (some models) to lower setting.</li> </ul>
Water collects in bottom of drawer.	<ul style="list-style-type: none"> <li>Washed vegetables and fruit drain while in the drawer.</li> </ul>	<ul style="list-style-type: none"> <li>Dry items before putting them in the drawer. Water collecting in bottom of drawer is normal.</li> </ul>
<b>WATER/MOISTURE/FROST OUTSIDE REFRIGERATOR</b>		
Moisture collects on outside of refrigerator or between doors.	<ul style="list-style-type: none"> <li>Weather is humid.</li> <li>Door is slightly open, causing cold air from inside refrigerator to meet warm air from outside.</li> </ul>	<ul style="list-style-type: none"> <li>This is normal in humid weather. When humidity is lower, the moisture should disappear.</li> <li>See PROBLEM column OPENING/CLOSING OF DOORS/DRAWERS.</li> </ul>