

Operating and Maintenance Instructions
56455- () MONSTER AIRMATIC

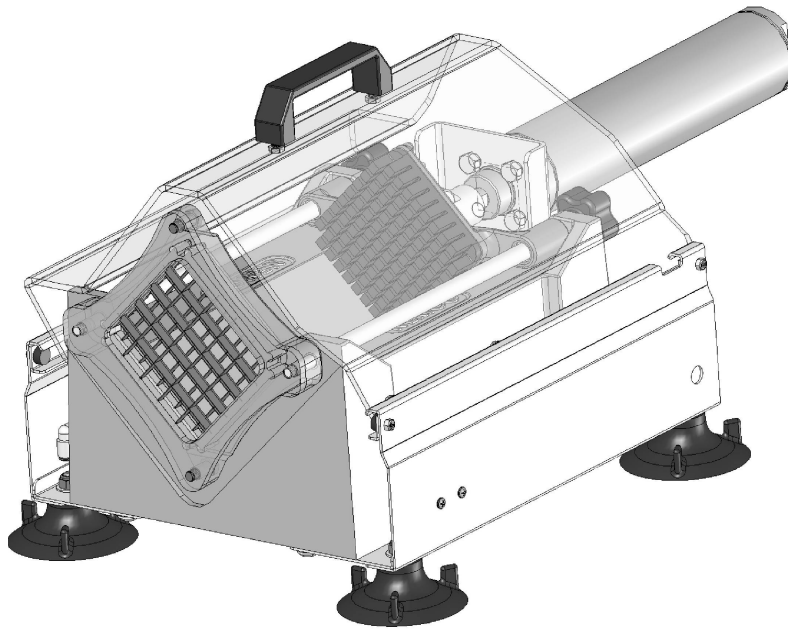



FOOD EQUIPMENT

56455-() Operating and Maintenance Instructions

FAILURE TO FOLLOW SAFETY INSTRUCTIONS
COULD RESULT IN SERIOUS PERSONAL INJURY

CAUTION: THIS POWER UNIT CAN BE DANGEROUS! THIS UNIT CAN CAUSE SERIOUS INJURY OR BLINDNESS TO THE OPERATOR AND OTHERS. THE WARNINGS AND SAFETY INSTRUCTIONS IN THIS MANUAL MUST BE FOLLOWED TO PROVIDE REASONABLE SAFETY AND EFFICIENCY IN USING THIS UNIT. THE OPERATOR IS RESPONSIBLE FOR FOLLOWING THE WARNINGS AND INSTRUCTIONS IN THIS MANUAL AND ON THE UNIT. READ THE ENTIRE OPERATOR'S MANUAL BEFORE USING THE UNIT. THE USE OF THIS UNIT SHOULD BE RESTRICTED TO PERSONS WHO HAVE READ, UNDERSTAND, AND FOLLOW THE WARNINGS AND INSTRUCTIONS IN THIS MANUAL AND ON THE UNIT. NEVER ALLOW CHILDREN TO OPERATE THE UNIT.

CAUTION AND WARNING DECALS LOCATED ON THIS UNIT:



NEMCO FOOD EQUIPMENT 301 Meuse Argonne, Hicksville, OH 43526
Phone: (419) 542-7751 Fax: (419) 542-6690 Toll free: 1-800-782-6761
www.nemcofoodequip.com



FOOD EQUIPMENT

56455-() Operating and Maintenance Instructions

IMPORTANT

CLEAN MACHINE THOROUGHLY BEFORE USING IT FOR THE FIRST TIME

1. To get the best operation and life from your machine, please read and comply with these instructions.
2. Clean machine thoroughly after each use using cleaning instructions below.
3. Minimize the use of alkaline cleaners as they may cause pitting and dulling of the finish.

SAFETY INSTRUCTIONS

FAILURE TO FOLLOW SAFETY INSTRUCTIONS COULD RESULT IN SERIOUS PERSONAL INJURY

1. Remember that the blades are **VERY SHARP!** Be careful when handling and operating the machine to keep hands away from the **BLADES**.
2. **NEVER** Grasp exposed cutting blades or cutting edges when picking up or holding the unit.
3. **Inspect unit before operation for loose or damaged parts. Do not use the unit unless it is in proper working order.**
4. **Never operate unit without plastic cover in place.**
5. **This unit is designed for operation by ONE (1) Person ONLY.**

CAUTION: ALWAYS DISCONNECT AIR HOSE FROM CUTTER WHEN TRANSPORTING, CLEANING, INSTALLING, OR SERVICING.

INSTALLATION

1. Install Air Compressor according to manufacturers guidelines.(Compressor Not Provided with Unit) Suggested size is 1.5 HP to 2HP with minimum SCFM of 5.6 at 90psi.
2. Connect air hose to air compressor. Use a 3/8" minimum internal diameter hose. Refer to Compressor Manual for necessary size fittings.
3. Connect air hose to cutting machine using quick disconnect fitting provided. Connect to "AIR CONNECTION" fitting on mounting bracket.
4. The FryKutter is to be mounted in a horizontal fashion. It comes equipped with suction cups for attachment to a stainless steel prep table.
5. If unit fails to operate properly when first used call NEMCO customer service at 1-800-782-6761.

Note: Air compressor should be equipped with a Filter and Regulator. The regulator should be set at 80psi minimum, 100psi maximum.

OPERATION OF FryKutter

1. With the COVER in the fully opened position, lay the prepared produce in the trough.
2. Remove hands and fingers from the cutting area.
3. Move COVER to fully closed position. The machine will cycle, cutting the produce. Occasionally if the produce is very large, or if it is positioned at an angle to the blades, this may have to be repeated to cut it entirely through.
CAUTION: Do not attempt to chop produce larger than the opening in the BLADE HOLDER.
4. Push block will "Return" to back of cutter when COVER is moved to fully opened position.
5. Clean the machine after cutting is completed, using cleaning instructions below.

TO CLEAN THE FryKutter

1. Always thoroughly wash the vegetable cutter after every use. The PLASTIC GUARD, PUSH BLOCK, BLADE AND HOLDER ASSEMBLY, AND CYLINDER are removable for easier cleaning. Always use warm water and mild detergent.
2. Wash the vegetable trough on the FRAME CASTING after each use.
3. Always thoroughly wash the PUSH BLOCK and the BLADE AND HOLDER ASSEMBLY.
4. Release the PUSH BLOCK by turning the THUMB SCREWS located on the PUSH BLOCK GUIDE in a counter clockwise motion until the PUSH BLOCK is loose.
5. To reassemble the PUSH BLOCK hold it up against the PUSH BLOCK GUIDE and fasten it by turning the THUMB SCREWS.
6. To remove the blade assembly, unscrew the GUIDE RODS while holding the WING NUTS. Pull back on the GUIDE RODS and carefully remove the BLADE AND HOLDER ASSEMBLY.
7. To reattach the BLADE AND HOLDER ASSEMBLY, hold the BLADE AND HOLDER ASSEMBLY tight to the bottom of the FRAME. Completely tighten both GUIDE RODS and WING NUTS so the BLADE AND HOLDER ASSEMBLY is held tightly against the bottom of the FRAME.

TO LUBRICATE

1. When necessary, lubricate GUIDE RODS and PINS at each joint with Mineral Oil or Food Grade Grease.
2. DO NOT LUBRICATE WITH COOKING OIL – IT GETS STICKY.
3. DO NOT LUBRICATE CYLINDER ROD-IT IS SELF LUBRICATING INTERNAL TO THE CYLINDER.

NEMCO FOOD EQUIPMENT 301 Meuse Argonne, Hicksville, OH 43526

Phone: (419) 542-7751 Fax: (419) 542-6690 Toll free: 1-800-782-6761

www.nemcofoodequip.com



FOOD EQUIPMENT

56455-() Operating and Maintenance Instructions

56455-() SERVICE PARTS:

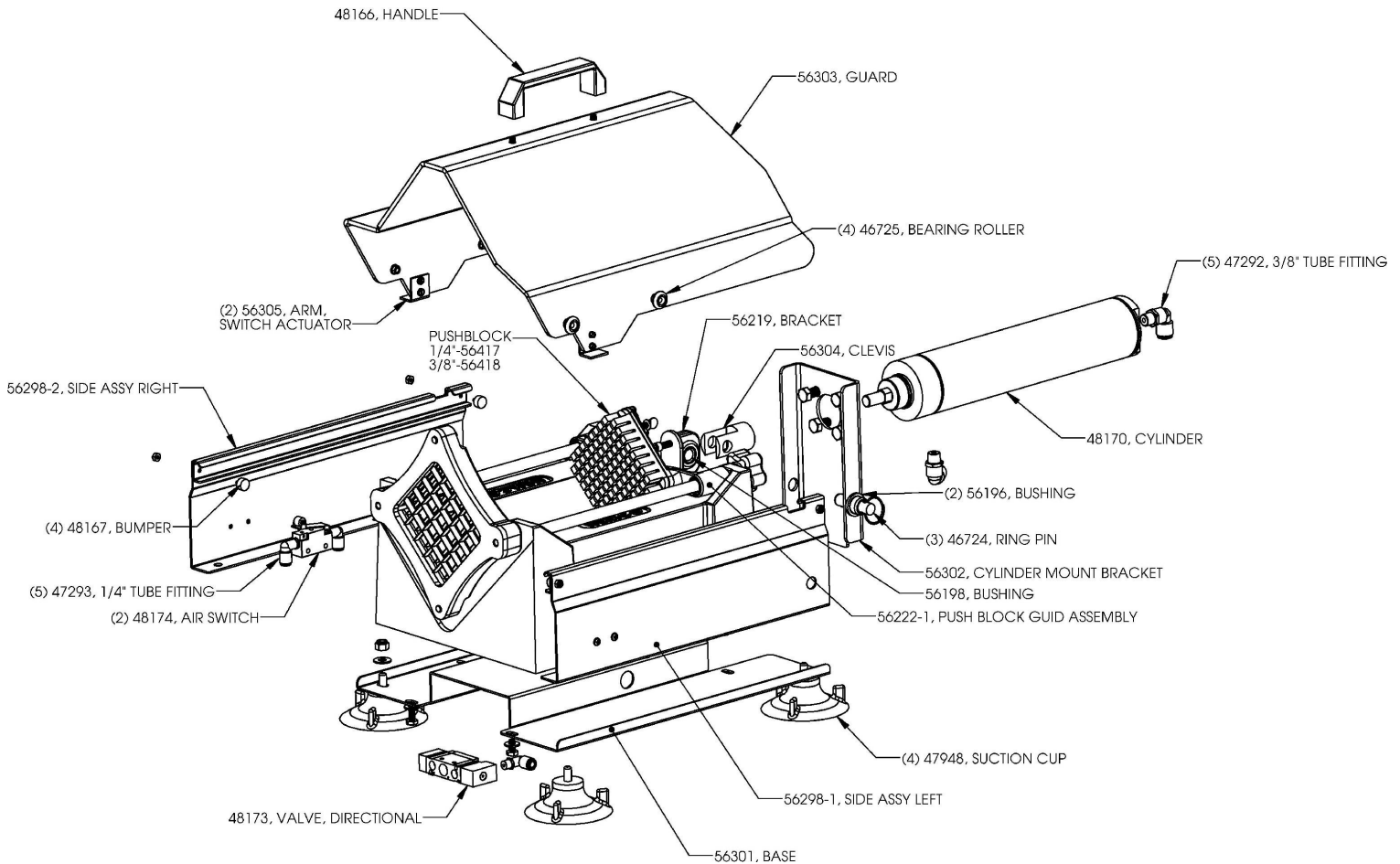

56222-1, PUSH BLOCK GUIDE ASSEMBLY INCLUDES

- (2) 56203, BUSHINGS
- (1) 56222, PUSH BLOCK GUIDE

BLADE ASSEMBLY, SLICE & CHOP

- 56424-1T, 1/4" CHOP DOUBLE TIER
- 56424-1, 1/4" CHOP SINGLE TIER
- 56424-2, 3/8" CHOP
- 56424-3, 1/2" CHOP
- 56424-5, 1/4" SLICE
- 56424-6, 3/8" SLICE

NOTE: ALL BLADE ASSEMBLIES OTHER THAN 56424-1T ARE FASTENED TO MACHINE USING (2) 45058 WINGNUTS.

NEMCO FOOD EQUIPMENT 301 Meuse Argonne, Hicksville, OH 43526
 Phone: (419) 542-7751 Fax: (419) 542-6690 Toll free: 1-800-782-6761
www.nemcofoodequip.com

