

# SERVER<sup>®</sup>

• E S S E N T I A L S •

## InSeason<sup>™</sup> Seasoning Dispenser

MODEL: INS



### ***Thank You***

for purchasing our InSeason Dispenser<sup>™</sup> —  
This handheld, lightweight model dispenses  
precise portions of granular seasonings for  
consistent taste and texture.

PERFECTLY SEASONED EVERY TIME!

# ASSEMBLY

WASH ALL PARTS  
PROPERLY BEFORE USE. See page 5.

- 1** SELECT PORTION TRIGGER  
(if more than one is provided).  
Trigger determines portion size dispensed.

PORTION SIZE	TRIGGER
1/2 TSP .....	GREEN
1/3 TSP .....	BLUE
1/4 TSP .....	BLACK
0.176 TSP .....	WHITE
0.115 TSP .....	WHITE
1/8 TSP .....	BURGUNDY
1/16 TSP .....	TAN

Portion size is also stamped in trigger cavity.

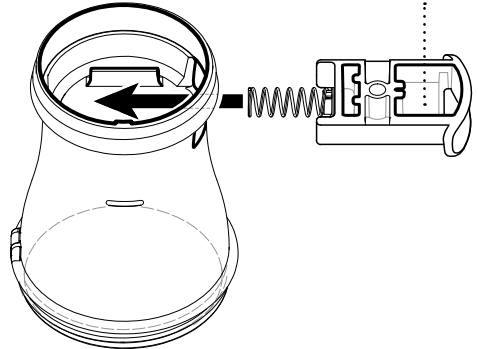

- 2** INSERT TRIGGER  
With unit upside down on countertop, slide spring end of trigger assembly into side slot. Smooth side of trigger should face down.

- 3** INSTALL CLOSER PLATE  
into unit body.  
Hold closer plate by grasp tab.  
Slowly push trigger assembly into unit body.  
Ensure spring does not pop loose.  
Insert closer plate rim tab into largest interior opening of trigger.

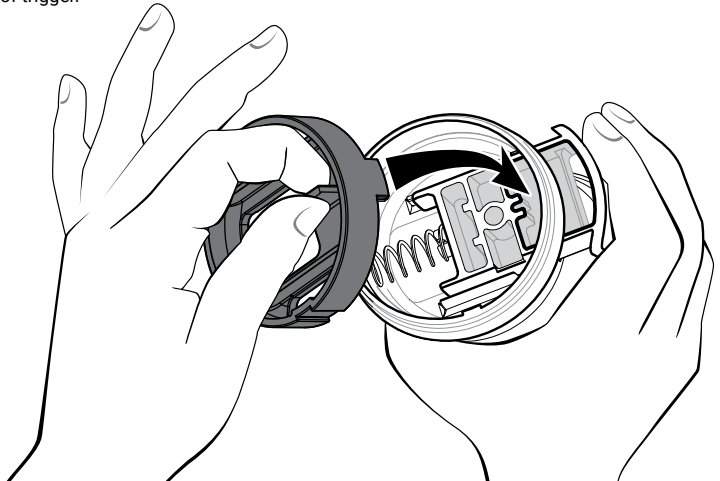

4

#### INSTALL SPREADER

onto unit body, rotating clockwise to tighten.

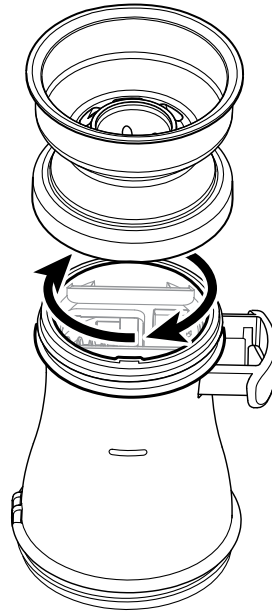

5

#### FILL UNIT

Flip unit right-side up and add granular ingredient.

6

#### INSTALL LID

onto unit body, rotating clockwise to tighten.

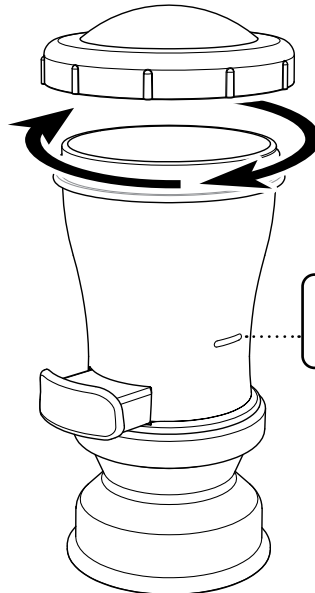

**IMPORTANT:** Refill when product level falls below fill line.

# SAFETY



According to food and safety regulations, most foods must be stored and/or served at certain temperatures or they could become hazardous. Check with local food and safety regulators for specific guidelines. Server Products, Inc. cannot be responsible for the serving of potentially hazardous product.

**The dispenser is designed for use in high-heat environments, but is not intended for direct contact with heat sources such as griddle surfaces.**

## IMPORTANT

**Clean, rinse, sanitize, and dry parts daily or regularly to comply with local sanitization requirements.**



NSF International listed.

# DISASSEMBLY

**1** REMOVE LID

**2** EMPTY UNIT

Pour out any remaining ingredient.

**3** REMOVE SPREADER

**4** REMOVE CLOSER PLATE

Set unit upside down on countertop.

Grasp tab of closer plate while holding trigger in.

Pull closer plate up and out of unit.

Slowly release trigger to home position, to ensure spring does not pop loose.

**5** REMOVE TRIGGER ASSEMBLY

from side slot of unit.

# CLEANING



- 1 WASH**  
After disassembly, wash all parts with dishwashing detergent and hot water.
- 2 RINSE**  
Fully rinse all parts thoroughly with clear water.
- 3 SANITIZE**  
all parts according to local sanitization requirements. All parts in contact with food must be sanitized.
- 5 AIR DRY**  
all parts fully before refilling.

## YES! Use dishwashing soap and hot water

- Dishwasher safe
- Do not use abrasive, caustic or ammonia based cleansers.
- Do not use cleansing agents with high concentrations of acid, alkaline or chlorine.
- Do not use metal scrapers or cleaning pads that could scratch surfaces.

# TROUBLESHOOTING

## INCONSISTENT PORTIONS?

*Heat and moisture can cause ingredients to settle and become packed in.*

- Shake unit to dislodge light clumping.
- Ensure ingredients have not become clogged within the unit—disassemble and inspect.
- Clean unit and air dry fully before refilling.
- Ensure ingredient level is above fill line. ....

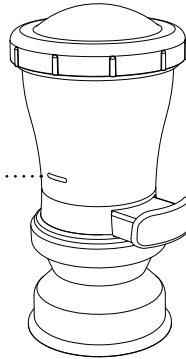

## TRIGGER WON'T PUSH IN?

- Ensure closer plate is properly installed with rim tab in the largest opening of trigger.

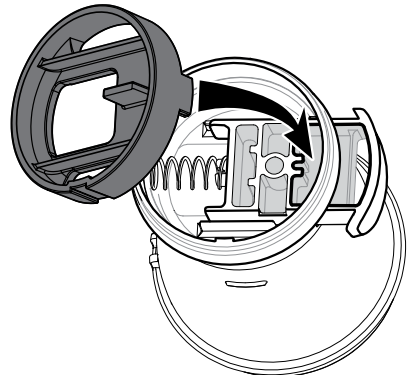
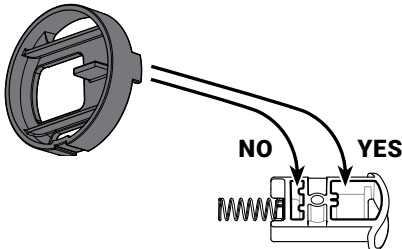

# DID YOU KNOW?

## THERE ARE TWO KINDS OF SPREADERS

Dispenser includes one of the following spreader styles.  
Spreader determines dispensing pattern.

### DROP PATTERN

4" Diameter

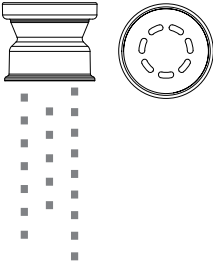

(patty or single serving)

### SPREAD PATTERN

Wide Disbursement

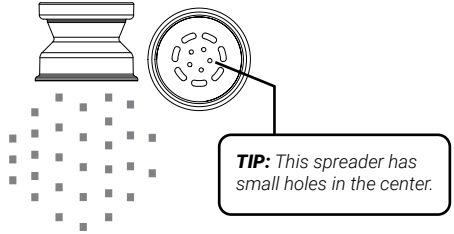

(fry dump or platter)

## SERVER PRODUCTS LIMITED WARRANTY

**2** YEAR  
WARRANTY

This Server product is backed by a two-year limited warranty against defects in materials and workmanship. See [Server-Products.com](http://Server-Products.com) for details.

## GENERAL SERVICE, REPAIR OR RETURNS

Before sending any item to Server Products for service, repair, or return, contact Server Products customer service to request a **Return Authorization Number**. Merchandise must be sent to Server Products with this number. Service is extremely prompt. Typically, units are repaired and ship out within 48 hours of receipt.

Merchandise being returned for credit must be in new and unused condition and not more than 90 days old and will be subject to a 20% restocking charge.

## RELATED ITEM

### EXPRESS™ CONDIMENT SYSTEMS

- Dispense from 1½ gallon pouches with a 16mm fitment, forming a sealed, sanitary system.
- Durable, plastic pumps have only a few parts, are quick to breakdown and achieve up to 98% evacuation.
- Models available for countertop and drop-in applications to dispense 1–6 condiments.



# INSEASON™ INDIVIDUAL PARTS

## AVAILABLE TRIGGER ASSEMBLIES

PORTION SIZE	TRIGGER	PART
1/2 TSP .....	GREEN .....	87126
1/3 TSP .....	BLUE .....	87127
1/4 TSP .....	BLACK .....	87128
0.176 TSP .....	WHITE-SALT .....	101374
0.115 TSP .....	WHITE .....	87129
1/8 TSP .....	BURGUNDY .....	87131
1/16 TSP .....	TAN .....	87132

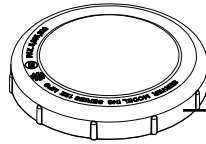
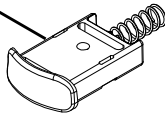

**LID**  
 87091 - AMBER  
 87883 - CLEAR  
 101535 - CLEAR TX2001

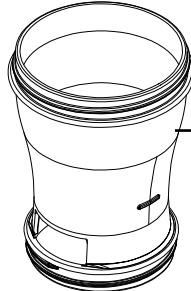

**BODY**  
 87092 - AMBER  
 87884 - CLEAR  
 101534 - CLEAR TX2001

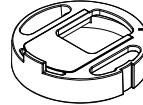

**CLOSER PLATE**  
 87095

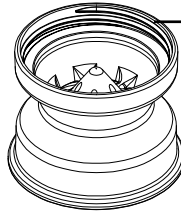

## AVAILABLE SPREADERS:

**4" DIAMETER DROP PATTERN**  
 87102 - AMBER  
 87886 - CLEAR

**CENTER DROP PATTERN**  
 87156 - CLEAR  
 101533 - CLEAR TX2001

**SPREAD PATTERN**  
 WIDE DISBURSEMENT  
 87096 - AMBER  
 87885 - CLEAR

## NEED HELP?

**Server Products Inc.**  
 3601 Pleasant Hill Road  
 Richfield, WI 53076 USA

**Chat with us!**  
[spsales@server-products.com](mailto:spsales@server-products.com)  
 262.628.5600 | 800.558.8722

Please be prepared with your **Model, P/N** and **Series** located on the lid or base of the unit.

Example:

MODEL XXXX		SERIES ##X##X
P/N #####		