

Sunbeam

Fiesta Folding Mixmaster®

Foldable benchtop mixer
with convenient storage lid

Instruction Booklet

MX1000

MX1000K

MX1000P

Please read these instructions carefully
and retain for future reference.



Contents

Sunbeam's Safety Precautions	1
Features of your Mixmaster® benchtop mixer	2
Using your Mixmaster® benchtop mixer	4
Folding your Fiesta Folding bench mixer	6
Mixing Guide	7
Oven Temperature Guide	8
Care and Cleaning	9
Cookery Tips for Best Results	10
Helpful Hints for Better Cake Making	11
Recipes	13

Important instructions – retain for future use.

تأكد من تفهم احتياطات السلامة المذكورة اعلاه

請務必理解上述的安全預防措施。

Assurez-vous que les précautions ci-dessus relatives à la sécurité sont bien comprises

Versichern Sie sich, dass die obenstehenden Sicherheitsmaßnahmen verstanden werden

Βεβαιώνετε πως οι παραπάνω προφυλάξεις ασφαλείας γίνονται κατανοητές

Pastikan bahwa tindakan-tindakan keselamatan seperti di atas dimengerti anda

Accertatevi che le suddette norme di sicurezza siano comprese a dovere

上記の注意事項をよくお読みになり、安全を御確認ください

Уверете се дека погоре споменатите мерки на претпазливост се добро разбрани

Asegúrese de que las precauciones de seguridad precedentes sean bien comprendidas

کاری بکنید کہ احتیاط‌های بالا حتماً درک بشوند

ต้องแน่ใจว่า ข้อควรระวังเรื่องความปลอดภัยข้างต้น เป็นที่เข้าใจกันดี

Yukarda belirtilen güvenlik önlemlerinin anlaşıldığından emin olunuz

Xin kiểm chắc rằng những biện pháp làm an toàn kể trên được hiểu rõ

Sunbeam's Safety Precautions

SAFETY PRECAUTIONS FOR YOUR SUNBEAM BENCHTOP MIXER.

- Switch off the appliance and disconnect from supply before changing accessories or approaching parts that move in use.
- Ensure fingers are kept well away from moving beaters and whisks.
- Only use the supplied mixing bowl.
- Do not remove the mixing bowl from the base of the Mixmaster® benchtop mixer whilst mixer is in use.
- When using extremely heavy loads the appliance should not be operated for more than 2 minutes. This does not apply to any of the recipes in this booklet.
- Should you be using a spatula during mixing, ensure that the spatula is kept well away from moving beaters and whisks.
- Never tilt back the head of the Mixmaster® benchtop mixer whilst the appliance is in operation.
- The Mixmaster® benchtop mixer must be switched off and unplugged before any cleaning.
- Do not restrain the mixer bowl while rotating.
- Turn the Mixmaster® benchtop mixer off and raise the head before removing the mixing bowl.
- Ensure long hair is tied back and young children are not near moving bowl.

Sunbeam is very safety conscious when designing and manufacturing consumer products, but it is essential that the product user also exercise care when using an electrical appliance. Listed below are precautions which are essential for the safe use of an electrical appliance:

- Read carefully and save all the instructions provided with an appliance.
- Always turn the power off at the power outlet before you insert or remove a plug. Remove by grasping the plug - do not pull on the cord.
- Turn the power off and remove the plug when the appliance is not in use and before cleaning.
- Do not use your appliance with an extension cord unless this cord has been checked and tested by a qualified technician or service person.
- Always use your appliance from a power outlet of the voltage (A.C. only) marked on the appliance.
- This appliance is not intended for use by persons (including children) with reduced physical, sensory or mental capabilities, or lack of experience and knowledge, unless they have been given supervision or instruction concerning use of the appliance by a person responsible for their safety.
- Children should be supervised to ensure that they do not play with the appliance.
- The temperature of accessible surfaces may be high when the appliance is operating.
- Never leave an appliance unattended while in use.
- Do not use an appliance for any purpose other than its intended use.
- Do not place an appliance on or near a hot gas flame, electric element or on a heated oven.
- Do not place on top of any other appliance.
- Do not let the power cord of an appliance hang over the edge of a table or bench top or touch any hot surface.
- Do not operate any electrical appliance with a damaged cord or after the appliance has been damaged in any manner. If damage is suspected, return the appliance to the nearest Sunbeam Appointed Service Centre for examination, repair or adjustment.
- For additional protection, Sunbeam recommend the use of a residual current device (RCD) with a tripping current not exceeding 30mA in the electrical circuit supplying power to your appliances.
- Do not immerse the appliance in water or any other liquid unless recommended.
- Appliances are not intended to be operated by means of an external timer or separate remote control system.
- This appliance is intended to be used in household and similar applications such as: staff kitchen areas in shops, offices and other working environments; farm houses; by clients in hotels, motels and other residential type environments; bed and breakfast type environments.

If you have any concerns regarding the performance and use of your appliance, please visit www.sunbeam.com.au or contact the Sunbeam Consumer Service Line. Ensure the above safety precautions are understood.

Features of your Sunbeam Fiesta Folding Mixmaster® benchtop mixer

Attachment eject button

The eject button effortlessly releases the beaters or whisks for easy cleaning.

Off-centre head and beaters

The head of the Mixmaster® benchtop mixer and beaters are positioned off-centre to the bowl to make it easier to add ingredients during mixing.

Stainless steel mixing bowl

3.5 litre mixing bowl is ideal for mixing ingredients and can be used as a separate bowl.

Dishwasher safe

The stainless bowl, stainless steel beaters and whisks are dishwasher safe for easy cleaning.

Plastic spatula

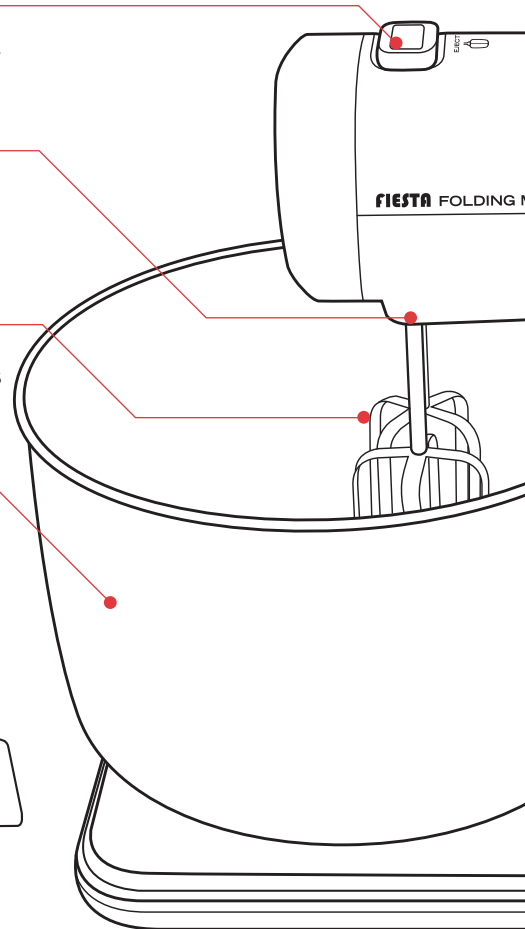
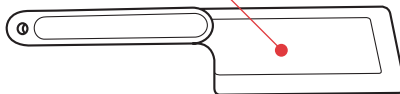

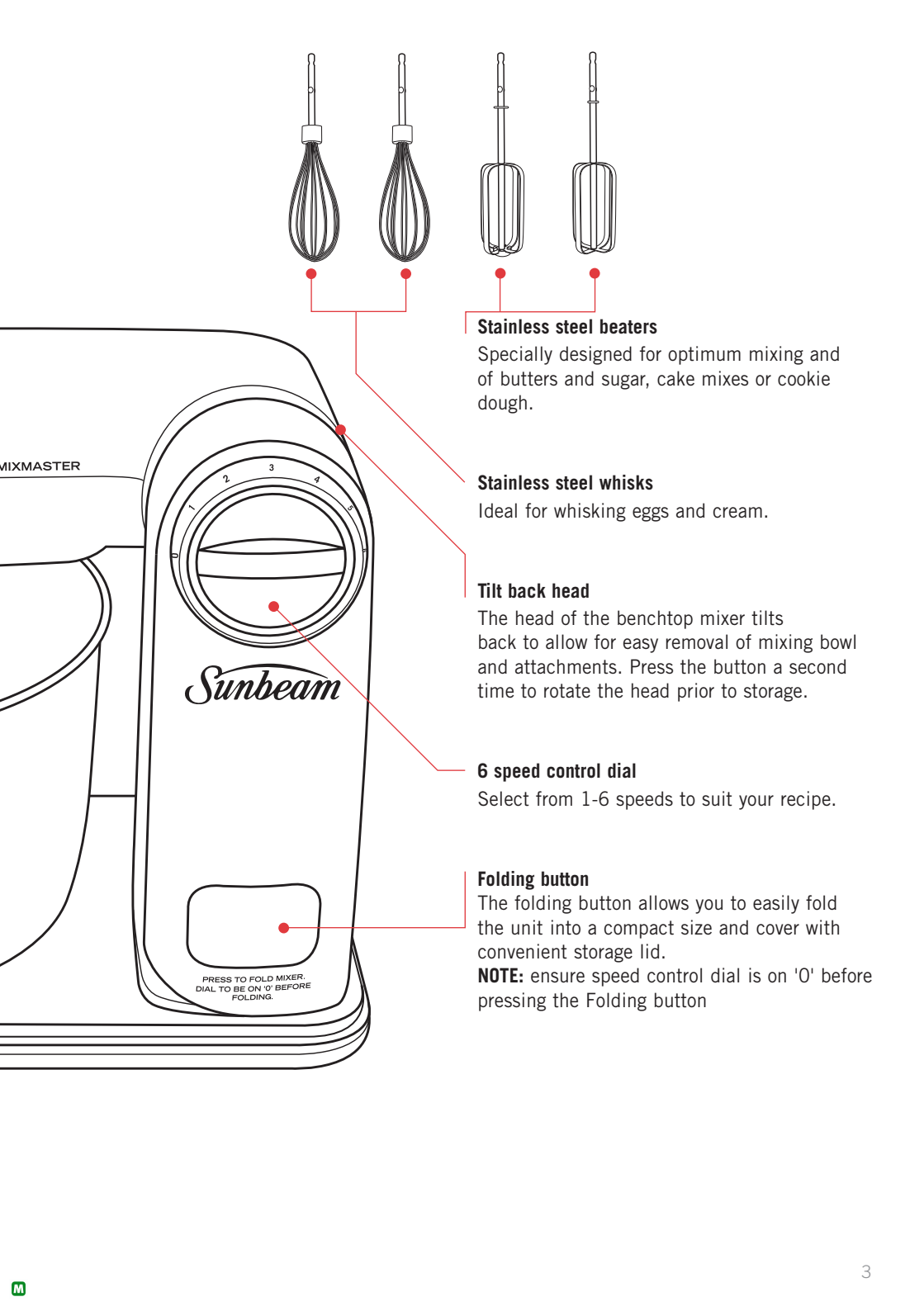

Stainless steel beaters

Specially designed for optimum mixing and of butters and sugar, cake mixes or cookie dough.

Stainless steel whisks

Ideal for whisking eggs and cream.

Tilt back head

The head of the benchtop mixer tilts back to allow for easy removal of mixing bowl and attachments. Press the button a second time to rotate the head prior to storage.

6 speed control dial

Select from 1-6 speeds to suit your recipe.

Folding button

The folding button allows you to easily fold the unit into a compact size and cover with convenient storage lid.

NOTE: ensure speed control dial is on '0' before pressing the Folding button

MIXMASTER

Sunbeam

PRESS TO FOLD MIXER.
DIAL TO BE ON '0' BEFORE
FOLDING.

Using your Fiesta Folding benchtop mixer

Before using your Fiesta Folding Mixmaster® benchtop mixer

1. Remove the storage lid. Lift the arm connected to the base in an upward position. The mixer base arm will lock into this position. See Figure 1.

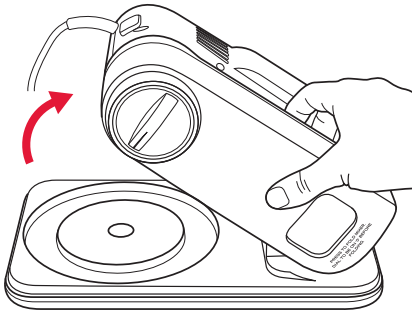

Figure 1

2. Rotate the head of the mixer in an anti-clockwise position until it is in place. The mixer head will lock into the first position.

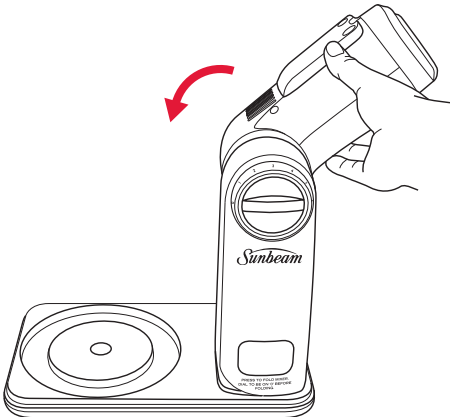

Figure 2

3. Place the grey turntable into position in the area where the bowl sits.
4. Select the desired attachments depending on the mixing task to be performed;
- Beaters for creaming butter and sugar, mixing cake mixes. Whisks for whisking cream and egg whites.
5. Insert selected attachment.

Note: Each beater is for a specific location. The beater with the drive button is to be closer to the edge of the bowl.

The whisks can be inserted in either location. See Figure. 3

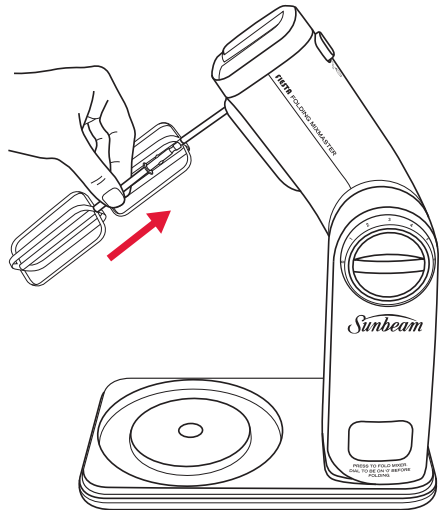

Figure 3

Note: Be sure both beaters click firmly in place, you may need to twist the attachments slightly to engage them in position prior to pushing them into place.

Using your Fiesta Folding benchtop mixer (continued)

5. Place mixing bowl onto grey turntable.
6. Press 'press to lift & rotate for storage' button to lower the head with the selected attachments (either, beaters or whisk) in place, into the mixing bowl. See Figures 4 & 5.

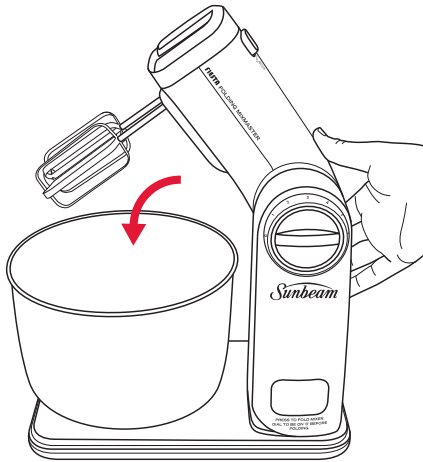

Figure 4

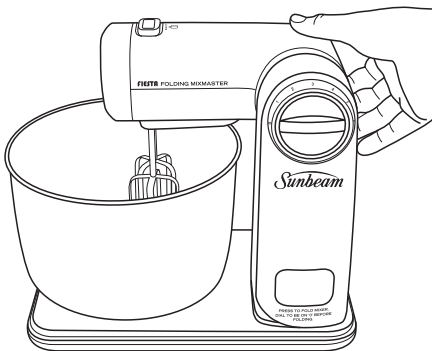

Figure 5

Using your Mixmaster® benchtop mixer

1. With the speed control dial in the '0' position, plug the power cord into a 230-240 volt power outlet.
2. Use the speed control dial to select your mixing speed. Clearly marked instructions for correct mixing speeds for each type of mixture are shown above the speed control dial.

Tip: Start mixing at slow speeds and increase speed gradually to prevent ingredients splashing out of the mixing bowl. When adding dry ingredients, particularly flour, lower the speed temporarily until ingredients are combined.

Using your Fiesta Folding benchtop mixer (continued)

3. When mixing is complete, turn the speed control dial to the '0' position and unplug the cord from the power outlet.
4. Press in 'press to lift & rotate for storage' button and ease the benchtop mixer head back until the mixer head is locked into the tilt back position.
5. To remove the particular attachments (either beaters or whisk), place fingers loosely around the attachments and hold down the attachment 'eject button' see Figure 6.

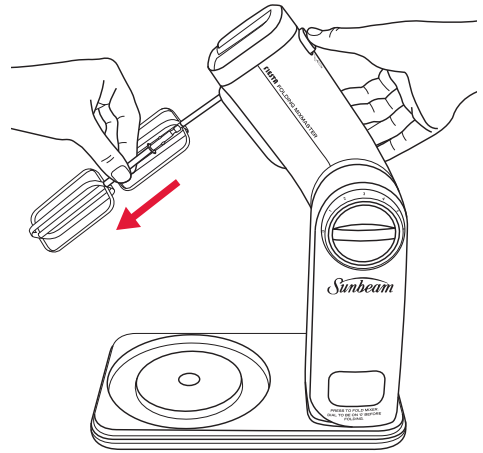

Figure 6

Storing your Fiesta Folding benchtop mixer

1. Turn dial to '0' press the 'press to lift & rotate for storage' button and rotate the head of the mixer in an anti-clockwise position until it is folded down.

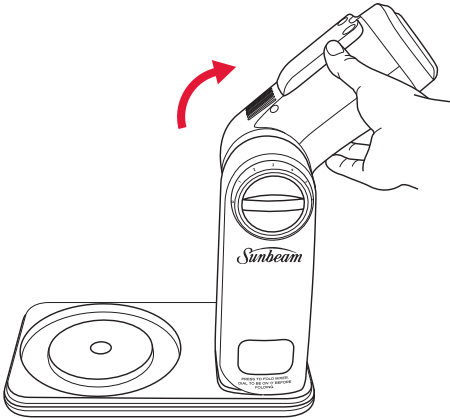

Figure 1

2. Press the 'press to fold mixer' button and fold the mixer arm down on to the base of the mixer.

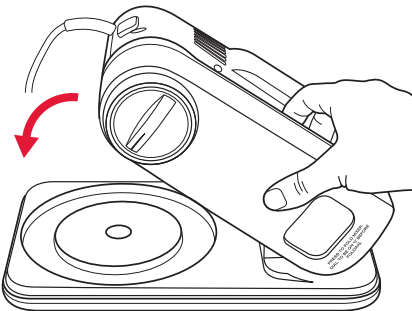

Figure 2

3. Place storage lid over mixer for easy storage.

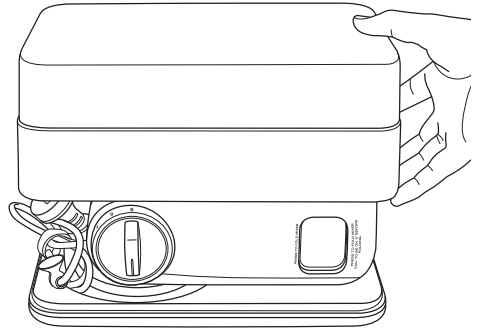

Figure 3

Mixing Guide

Please keep in mind that the various mixing tasks and related speeds, listed in the table below, may vary slightly from recipe to recipe.

Please refer to it regularly as you develop your understanding of how different ingredients interact when mixing.

SPEED SETTING RANGE	MIXING TASK
1.	FOLDING Scones/Pastry Biscuit dough Tea Cakes
2.3.4	LIGHT MIXING Sauces & Puddings Custard/Icing Packet Mixes CREAMING & BEATING Butter & Sugar Cream Cheese Heavy Batters
5.6	WHIPPING & WHISKING Cream Egg Whites & Meringues Marshmallow

NOTES: For most recipes, it is better to begin your mixing on a slower speed until the ingredients begin combining, then move to the appropriate speed range for the particular task.

Generally there is no one set speed for an entire recipe. You will need to change the speed of the Fiesta Folding Mixmaster® benchtop mixer depending on what stage of the recipe you are working on. This is communicated in the recipe section.

When mixing larger quantities you may need to increase the mixer speed due to the amount of mixing required and the larger load on the machine.

When building up a recipe that requires the addition of dry ingredients, such as flour, slow the speed down whilst these ingredients are being added to avoid a snow storm effect. Once the extra ingredients begin combining then slowly increase to the appropriate speed for the particular mixing task.

Oven Temperature Guide

For your information, the following temperature settings are included as a guide. These settings may need to be adjusted to suit the individual range.

Thermostat Settings			
DESCRIPTION OF OVEN TEMPERATURES	Degrees Celcius °C	Degrees Farenheit °F	Gas Mark
Very Slow	120	250	½
Slow	140-150	300	1-2
Moderately Slow	160	325	3
Moderate	180	350	4
Moderately hot	200	400	6
Hot	220	425	8
Very Hot	240	475	9

Note: If using fan forced ovens be sure to turn the temperature down by 20°C. Also check recipes at the back of this booklet.

Care and Cleaning

Before cleaning your Fiesta Folding Mixmaster® benchtop mixer, ensure the power is turned off at the power outlet, then remove the plug.

Wipe over the outside area of the mixer and turntable with a dampened cloth and polish with a soft dry cloth. Wipe any excess food particles from the power cord. Wash the mixing bowl, beaters and whisks in warm soapy water or dishwasher. Wipe dry after washing.

Storage

Keep your Fiesta Folding Mixmaster® conveniently in the cupboard with the storage lid on. This will keep the mixer clean and dust free. A velcro strap is attached to the cord to help with cord management.

Place the beaters and whisks into the bowl for easy storage.

Note: Never wind the power cord around the motor after use as the warmth of the motor may cause damage to the power cord.

Cookery Tips for Best Results

1. Before starting, read the recipe completely.
2. Refrigerated ingredients, i.e. butter and eggs should be at room temperature before mixing begins. Set these ingredients out ahead of time.
3. Before starting your recipe preheat oven to baking temperature recommended in the recipe.
4. Assemble all ingredients and utensils near the mixer.
5. To eliminate the possibility of shells or deteriorated/off eggs in your recipe, break eggs into a separate container first, then add to the mixture.
6. When mixing egg whites, be sure the bowls and beaters are thoroughly cleaned and dried as even the smallest amount of oil on beaters or bowl may cause the egg whites not to aerate.
7. Always start mixing at slow speeds. Gradually increase to the recommended speed as stated in the recipe.
8. Do not overbeat. Be careful that you only mix/blend mixtures for the recommended time specified in your recipe. Fold in dry ingredients only until just combined. Always use the low speed. At any stage of mixing, over beating can cause toughness, coarse texture, lack of rising or excessive shrinkage. Climatic conditions, seasonal temperature changes, temperature of ingredients and their texture variation from area to area all play a part in the required mixing time and the results achieved.
9. All recipes have been kitchen tested, but should you find it necessary to vary the ingredients or the size of the tin etc. allow for a variation in cooking time. Always test for baked foods before removing from the oven or the cooking appliance.
10. During mixing, ingredients may splash to the sides of the bowl. To scrape the bowl, turn the beaters and bowl Control Dial to the '0' position and using a plastic or rubber spatula, scrape the bowl. NEVER USE A KNIFE, METAL SPOON OR FORK, as this may cause damage to the beaters and bowl. A light scraping after the addition of each ingredient assists in achieving efficient mixing.

Recipes

Classic Sponge Cake

Serves: 8

4 eggs

$\frac{3}{4}$ cup caster sugar

1 cup wheaten cornflour

1 teaspoon cream of tartar

$\frac{1}{2}$ teaspoon bicarbonate of soda

Whipped cream and jam, to serve

1. Preheat oven to 180°C. Grease and line two 22cm round cake pans.
2. Place eggs in bowl. Using the whisk attachments, whip eggs on Speed 6 until thick and creamy, about 5 minutes. Continue beating, gradually adding the sugar until dissolved.
3. Sift cornflour, cream of tartar and bicarbonate of soda twice onto baking paper. Sift into egg mixture and use a large metal spoon to fold until combined.
4. Divide mixture evenly among cake pans. Bake for about 20 minutes or until cooked through.
5. Turn cakes immediately onto a prepared rack.
6. Serve cool sponges sandwiched together with whipped cream and jam. Dust with icing sugar.

Buttermilk Pancakes

1 cup self-raising flour

2 tablespoons caster sugar

$\frac{1}{2}$ teaspoon bicarbonate soda

1 cup buttermilk

2 tablespoons vegetable oil

1 egg, lightly beaten

60g butter, melted

Butter, for cooking

1. Sift dry ingredients into the mixing bowl. Add all the other ingredients to the bowl. Using the beater attachments beat on Speed 2 until well combined.
2. Heat a large non-stick frying pan over medium heat. Melt a little butter in the pan and pour $\frac{1}{4}$ cup of mixture at a time. Flip pancakes when bubbles rise to the surface and they are golden underneath. Cook until golden on other side. Remove from pan and keep warm. Repeat with remaining batter.
3. Serve pancakes with maple syrup.

Recipes (continued)

Basic Butter Cake

175g butter, room temperature
1 cup caster sugar
1 teaspoon vanilla extract
3 eggs
2 ¼ cups self-raising flour
¾ cup milk

1. Preheat oven to 180°C. Grease and line a 20cm round cake pan.
2. Place all ingredients in the bowl. Using the beater attachments beat on Speed 2 until combined. Increase to Speed 5. Beat for a further 4-5 minutes or until light and fluffy.
3. Pour mixture into prepared pan. Bake for about 1 hour or until a skewer inserted into the centre comes out clean. Stand cake for 5 minutes then turn onto a wire rack to cool.

Variations:

- Dark Chocolate Butter Cake: Increase the total amount of eggs to five. Add ¾ cup of good quality cocoa to the finished mixture. Gently fold to combine. Cook as per above instructions.
- Lemon Butter Cake: Add 1 tablespoon of lemon juice and 2 tablespoons of lemon rind to the finished mixture. Gently fold to combine. Cook as per above instructions.
- Orange Butter Cake: Add 1 tablespoon of orange juice and 2 tablespoons of orange rind to the finished mixture. Gently fold to combine. Cook as per above instructions.

Best Ever Banana Cake

125g butter, room temperature
½ cup caster sugar
2 teaspoons vanilla extract
2 eggs
400g mashed bananas
½ cup shredded coconut
1 ¾ cup self-raising flour
1 teaspoon bicarbonate of soda
⅓ cup milk

TOPPING:

75g butter, melted
¾ cup maple syrup
¾ cup shredded coconut, toasted

1. Preheat oven to 180°C. Grease a 28cm fluted ring pan.
2. Using the beater attachments on Speed 5, beat cream the butter and sugar together until light and fluffy. Add vanilla essence and beat a further 1 minute.
3. Reduce Speed to 3. Add eggs one at a time and beat until well combined.
4. Using a wooden spoon, fold through the mashed banana and coconut.
5. Sift the flour and bicarbonate of soda together and fold through the banana mix alternately with the milk.
6. Spoon into prepared pan and bake for 30 to 35 minutes or until golden brown and slightly pulling away from the sides of the pan. Turn out onto a wire rack to cool.

TOPPING

1. Combine the butter, syrup and toasted coconut together and pour over the cake whilst still warm.
2. Serve with double dollop cream.

Recipes (continued)

Carrot and Date Cake

- 1 ½ cups brown sugar
- ¾ cup vegetable oil
- 3 eggs
- 1 ½ cups plain flour
- 1 ½ teaspoons baking powder
- 1 teaspoon bicarbonate of soda
- 1 teaspoon ground cinnamon
- 2 cm piece of fresh ginger, grated
- 2 ½ cups grated carrot
- ½ chopped dried dates
- ½ cup shredded coconut

Yoghurt Icing Glaze:

- ½ cup vanilla yoghurt
- 1 ½ cups soft icing sugar
- Grated rind of 1 lemon

1. Preheat oven to 180°C. Grease a fluted ring cake pan or a 28cm spring form pan.
2. Using the beater attachments on Speed 3, beat sugar and oil for 2 minutes. Add eggs one at a time beating well after each addition.
3. Sift all dry ingredients together and then fold through the ginger, carrot, dates and coconut.
4. Combine the wet and dry ingredients together and stir with a wooden spoon until well combined.
5. Pour into pan and bake for 50 to 55 minutes. Turn out onto a wire rack to cool.
6. To make icing glaze – combine all ingredients and pour over cooled cake.

Lemon Ginger Cake

Makes: 1 cake

- 3 cups plain flour
- ½ cup crystalized ginger
- 2 teaspoons ground ginger
- 2 tablespoons lemon zest
- 1 teaspoon baking soda
- 1 teaspoon salt
- 250g butter, room temperature
- 2 cups caster sugar
- 6 eggs
- ⅓ cup lemon juice
- 1 cup sour cream

1. Preheat oven to 180°C. Grease a 12-cup Bundt cake pan.
2. In a bowl combine flour, ginger, ginger powder, lemon zest, baking soda and salt. Set aside.
3. Using the beater attachments on Speed 4, beat butter and sugar until light and fluffy, about 4-5 minutes.
4. Add eggs one at a time, making sure to beat well after each addition. Add lemon juice.
5. Reduce speed to 2, add sour cream and flour mixture. Mix until just combined.
6. Spoon mixture into prepared pan. Bake for 50 minutes or until cooked. Turn onto wire rack to cool.

Recipes (continued)

Raspberry and White Chocolate Cupcakes

Makes: 12 cupcakes

125g butter, room temperature
1 cup caster sugar
3 eggs
1 ½ cups self-rising flour
¼ cup milk
1 cup frozen raspberries
¾ cup white chocolate chips
½ cup plain flour

1. Preheat oven to 180°C. Lightly grease 12 x ½ cup capacity muffin pan.
2. Using the beater attachments on Speed 5 beat butter and sugar until light and fluffy, about 4-5 minutes.
3. Reduce speed to 2, add eggs, self-raising flour and milk. Continue to mix until combined.
4. Add remaining ingredients. Beat until just combined.
5. Spoon mixture into prepared pan. Bake for 20-25 minutes or until cooked, turn onto a wire rack to cool.

Date and Walnut Loaf

Makes: 1 loaf

1 ½ cups dates, chopped
1 cup rolled oats
1 ¼ cups boiling water
¼ cup maple syrup
1 ⅔ cups plain flour
1 ½ cups walnuts, chopped
½ cup brown sugar
1 teaspoon bicarbonate soda

1. Preheat oven to 180°C. Grease and line a 25cm x 12cm loaf pan.
2. Place dates and oats in a bowl. Cover with hot boiling water. Set aside 10 minutes.
3. Using the beater attachments on Speed 3 beat all ingredients until just combined.
4. Spoon mixture into prepared pan. Bake for 50-55 minutes or until cooked through. Turn onto a wire rack to cool.

Recipes (continued)

The Best Chocolate Brownies

Add half a cup of your favourite dried fruit or nuts to this batter.

Makes: 16 pieces

200g butter, melted

200g good-quality dark chocolate, melted

1 cup golden caster sugar

3 eggs

½ cup cocoa powder

⅓ cup plain flour

1. Preheat oven to 180°C. Grease and line a 18cm x 28cm slice pan.
2. Using the whisk attachments on speed 4 whisk sugar and eggs until pale and fluffy. Gently fold through melted chocolate and butter.
3. Reduce speed to 2. Sift cocoa and flour over mixture and mix until just combined.
4. Spoon mixture into prepared pan. Bake for 20-25 minutes or until cooked through. Turn onto a wire rack to cool.

Traditional Blondie's

Add half a cup of your favourite dried fruit or nuts to this batter.

Makes: 16 pieces

115g butter, melted

1 cup brown sugar

1 egg

1 teaspoon vanilla extract

1 cup plain flour

½ teaspoon salt

1. Preheat oven to 180°C. Grease and line a 18cm x 28cm slice pan.
2. Combine all ingredients. Using the beater attachments on Speed 5, mix until just combined.
3. Spoon mixture into prepared pan. Bake for 20-25 minutes or until cooked through. Turn onto a wire rack to cool.

Recipes (continued)

Spiced Carrot Cake

Makes: 1 cake

- 2 cups grated carrot
- 2 cups self-rising flour
- 1 ½ cups brown sugar
- 1 cup vegetable oil
- 1 cup walnuts, chopped
- 1 tablespoon orange zest
- 2 teaspoons bicarbonate soda
- 2 teaspoons ground cinnamon
- 1 teaspoon ground ginger
- 1 teaspoon ground nutmeg
- 4 eggs

ICING:

- 250g cream cheese, room temperature
- 50g butter, room temperature
- 3 cups icing sugar

1. Preheat oven to 180°C. Grease and line a 23cm cake pan.
2. Using the beater attachments on Speed 4 beat all the cake ingredients until just combined.
3. Spoon mixture into prepared pan. Bake for 50-55 minutes or until cooked through. Turn out onto a wire rack to cool.
4. ICING: Using the beater attachments on Speed 4, beat cream cheese and butter until light and fluffy. Gradually add icing sugar over a 5 minute period.
5. Cover top and sides of cooled cake with icing. Serve.

Chocolate Cake with Chocolate Ganache

Makes: 1 cake

- 115g dark chocolate, chopped
- ½ cup good quality cocoa powder
- ½ cup hot water
- 1 ¾ cups caster sugar
- 1 ¾ cups plain flour
- 1 ½ teaspoons baking soda
- 1 teaspoon salt
- 4 eggs
- 2 egg yolks
- 170g butter, room temperature
- 1 cup buttermilk

GANACHE:

- 600g dark chocolate, chopped
- 1 cup thickened cream

1. Preheat oven to 180°C. Grease and line a 23cm cake pan.
2. In a heatproof bowl combine chocolate, cocoa powder and hot water. Place over a pan of simmering water. Add ½ cup of sugar and continue to stir until dissolved. Remove from heat. Set aside.
3. In a separate bowl sift flour, baking soda and salt.
4. Using the beater attachments on Speed 4 beat eggs and egg yolks until combined. Add remaining sugar and continue to beat until light and fluffy.
5. On Speed 2, add chocolate mix and beat until thoroughly combined. Add butter and mix until incorporated. Add buttermilk.
6. On Speed 1, add flour mixture and fold until just combined.
7. Spoon mixture into prepared pan. Bake for 20-25 minutes or until cooked through. Allow cakes to cool in the pan for 10 minutes before turning out onto a wire rack to cool.

Recipes (continued)

8. Ganache: Combine chocolate and cream in a heat proof bowl. Place in microwave and heat for 20 seconds intervals until chocolate has melted and is smooth. Place in refrigerator until firm.
9. Once firm; cover top and sides of cooled cake with icing. Serve.

Chocolate Chip Cornflake Cookies

Makes: approximately 20 cookies

125g butter, room temperature

$\frac{2}{3}$ cup brown sugar

1 teaspoon vanilla extract

2 eggs

1 $\frac{3}{4}$ cups self-rising flour

1 $\frac{1}{2}$ cornflakes, lightly crushed

1 cup dark chocolate chips

1. Preheat oven to 180°C. Grease and line two baking trays.
2. Using the beater attachments on Speed 5, beat butter, sugar and vanilla until pale and fluffy.
3. Add eggs one at a time, making sure to beat well after each addition.
4. Reduce speed to 1. Add flour, corn flakes and chocolate chips to the mixture. Mix until just combined.
5. Roll dough into 1 tablespoon sized balls. Place on prepared tray and slightly flatten. Bake for 15-20 minutes or until golden. Allow to cool on tray for 5 minutes before transferring to a wire rack to cool.

Lemon Meringue Slice

Makes: approximately 16 pieces

2 packets plain sweet biscuits

125g butter, melted

395g can sweetened condensed milk

4 tablespoons lemon juice

2 tablespoons lemon zest

2 eggs, separated

$\frac{1}{2}$ cup caster sugar

1 $\frac{1}{2}$ cups shredded coconut

1. Preheat oven to 180°C. Grease and line 18cm x 28cm lamington pan.
2. Place biscuits in the bowl of a food processor and pulse until a fine crumb. Add butter and continue to process until combined.
3. Press crumb mixture into the base of the prepared pan. Refrigerate for 30 minutes or until firm.
4. In a bowl combine condensed milk, lemon juice, zest and egg yolks. Pour over biscuit base.
5. Using the whisk attachment whisk egg whites on Speed 6 until soft peaks form. Add sugar and continue to mix until light and fluffy. On Speed 1 fold through coconut and spread over lemon mixture. Bake for 25 minutes or until golden. Allow to cool in pan. Cut into squares. Serve.

Frostings and Icings

Low-fat Cinnamon Tea Cake

Serves: 8

60g reduced-fat dairy spread at room temperature

$\frac{1}{3}$ cup caster sugar

1 egg

$\frac{3}{4}$ cup self-raising flour

$\frac{1}{4}$ cup milk

15g reduced-fat dairy spread, extra, melted

2 teaspoons caster sugar, extra

$\frac{1}{2}$ teaspoon ground cinnamon

1. Preheat oven to 180°C. Grease and line a 20cm-round cake pan.
2. Using the beater attachment on Speed 3, beat dairy spread and sugar until light and fluffy. Add egg and milk, beating until combined.
3. Sift flour over mixture. Reduce speed to Speed 1 and mix until just combined. Spoon batter into prepared pan and smooth surface. Bake for about 20-25 minutes or until a skewer inserted into the centre comes out clean. Turn out onto a wire rack to cool.
4. Brush top of cake with extra melted spread. Sprinkle with sugar and cinnamon. Serve.

Fluffy Butter Frostings

100g butter, room temperature

4 cups pure icing sugar

$\frac{1}{3}$ cup milk

1 teaspoon vanilla extract

1. Place all ingredients in a bowl. Using the beater attachments, beat on Speed 2 until smooth.

Tip: Add a few drops of food colouring while beating to achieve the desired colour.

Glaze Icing

$\frac{1}{4}$ cup caster sugar

$\frac{1}{4}$ cup water

1 teaspoon powdered gelatin

1. Place all ingredients in a small saucepan. Stir over low-medium heat until sugar has just dissolved.

2. Brush warm on top of baked sweet goods.

Tip: Do not allow the mixture to boil. This will de-activate the gelatin.

Frostings and Icings (continued)

Whipped Dark Chocolate Ganache

200g dark chocolate, chopped

$\frac{2}{3}$ cup thickened cream

1. Place chocolate and cream in a small saucepan. Stir over low heat with a metal spoon until smooth. Transfer to a bowl. Cover and refrigerate for about 1 hour or until spreadable.
2. Using the beater attachments, beat on Speed 3 until light and pale in colour.

12 Month Warranty

This Sunbeam product is covered by a 12 month replacement or repair warranty, which is in addition to your rights under the Australian Consumer Law (if your product was purchased in Australia) or New Zealand Consumer Guarantees Act (if your product was purchased in New Zealand).

Should you experience any difficulties with your product during the warranty period, please contact our customer service line for advice on 1300 881 861 in Australia, or 0800 786 232 in New Zealand.

Alternatively, you can send a written claim to Sunbeam to:

Australia

Units 5 & 6, 13 Lord Street
Botany NSW 2019 Australia

New Zealand

26 Vestey Drive
Mt Wellington, Auckland New Zealand

Upon receipt of your claim, Sunbeam will seek to resolve your difficulties or, if the product is defective, advise you on how to obtain a replacement or refund.

To assist us in managing warranty claims, we recommend you register your product as soon as practicable after purchase by creating a MySunbeam account on our website and send a copy of your original receipt to Sunbeam.

In order to make a claim under our warranty, you must have the original proof of purchase documentation for the product and present it when requested.

Should your product develop any defect within 12 months of purchase because of faulty materials or workmanship, we will replace or repair it, at our discretion, free of charge. A product presented for repair may be replaced by a refurbished product of the same type rather than being repaired. Refurbished parts may be used to repair the product.

Our replacement or repair warranty only applies where a defect arises as a result of faulty material or workmanship during the warranty period. Your warranty does not cover misuse or negligent handling (including damage caused by failing to use the product in accordance with this instruction booklet), accidental damage, or normal wear and tear.

Your warranty does not:

- cover freight or any other costs incurred in making a claim, consumable items, accessories that by their nature and limited lifespan require periodic renewal (such as filters and seals) or any consequential loss or damage; or
- cover damage caused by:
 - power surges, power dips, voltage supply problems, or use of the product on incorrect voltage;
 - servicing or modification of the product other than by Sunbeam or an authorised Sunbeam service centre;
 - use of the product with other accessories, attachments, product supplies, parts or devices that do not conform to Sunbeam specifications; or
 - exposure of the product to abnormally corrosive conditions; or
- extend beyond 3 months if the product is used in commercial, industrial, educational or rental applications.

The benefits given to you by our warranty are in addition to other rights and remedies under law in relation to the product.

In Australia our goods come with guarantees that cannot be excluded under the Australian Consumer Law. You are entitled to a replacement or refund for a major failure and for compensation for any other foreseeable loss or damage. You are also entitled to have the goods repaired or replaced if the goods fail to be of acceptable quality and the failure does not amount to a major failure.

Our goods also come with guarantees that cannot be excluded under the New Zealand Consumer Guarantees Act.

If your warranty claim is not accepted, we will inform you and if requested to do so by you, repair the product provided you pay the usual charges for such repair. You will also be responsible for all freight and other costs.

Should your product require repair or service after the warranty period, contact your nearest Sunbeam service centre. For a complete list of Sunbeam's service centres, visit our website or call our customer service line for advice on 1300 881 861 in Australia, or 0800 786 232 in New Zealand.

Need help with your appliance?

Contact our customer service team or visit our website for information and tips on getting the most from your appliance.

In Australia

Visit www.sunbeam.com.au

Or call 1300 881 861

In New Zealand

Visit www.sunbeam.co.nz

Or call 0800 786 232

 is a registered trademark.

'Mixmaster®' is a trademark of Sunbeam Corporation.

Made in China.

Due to minor changes in design or otherwise, the product may differ from the one shown in this leaflet.

© Copyright. Sunbeam Corporation Limited 2013.

ABN 45 000 006 771

Units 5 & 6, 13 Lord Street
Botany NSW 2019 Australia

Unit 3, Building D
26 Vestey Drive
Mt Wellington Auckland
New Zealand

Sunbeam Corporation is a division of GUD Holdings Ltd.