

# Operator's Manual

## CRAFTSMAN

### 9 Amp 7 1/4-in. Compound Miter Saw with Laser Trac™

Model No.  
320.21180

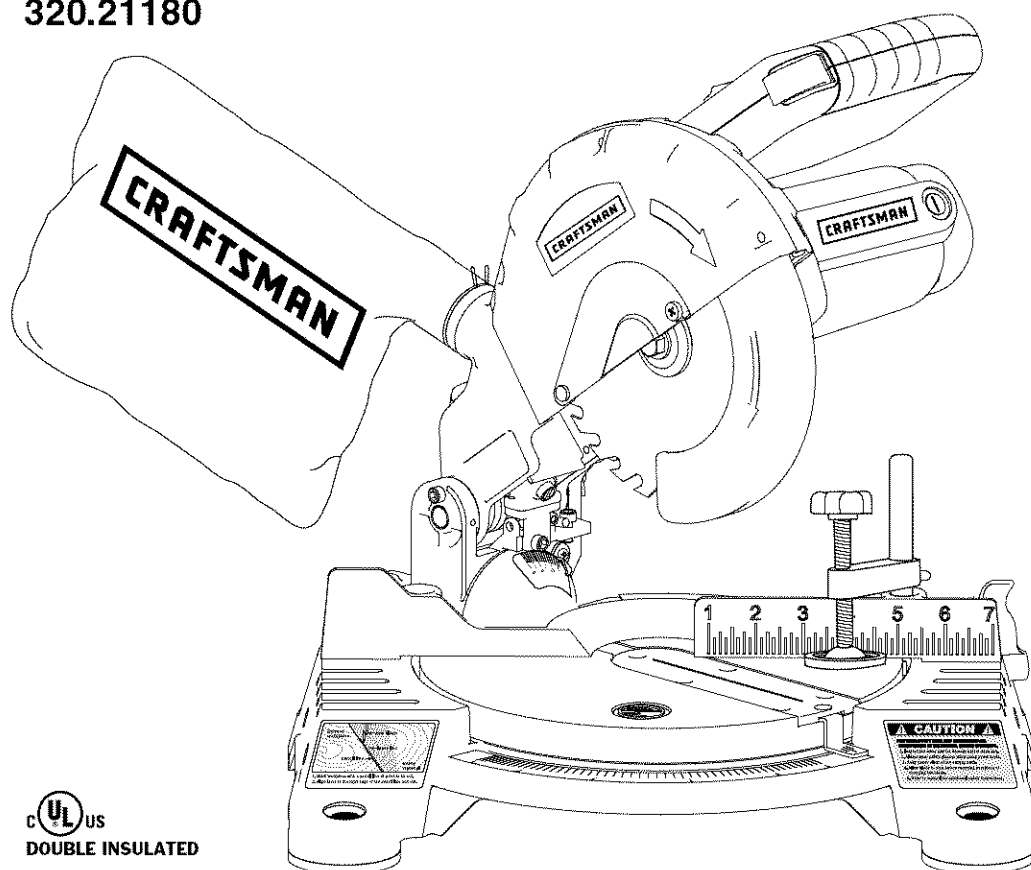

 **DOUBLE INSULATED**

**CAUTION:** Read, understand and follow all Safety Rules and Operating Instructions in this Manual before using this product.

- WARRANTY
- SAFETY
- UNPACKING
- ADJUSTMENT
- OPERATION
- MAINTENANCE

Sears, Roebuck and Co., Hoffman Estates, IL 60179 U.S.A.

Visit our Craftsman web site: [www.sears.com/craftsman](http://www.sears.com/craftsman)

## TABLE OF CONTENTS

Warranty.....	Page 2
Safety Symbols.....	Page 3
Safety Instructions.....	Pages 4-11
Glossary of Terms.....	Pages 12-13
Unpacking.....	Page 14
Description.....	Pages 15-18
Assembly.....	Page 19
Adjustments.....	Pages 20-24
Operation.....	Pages 24-35
Maintenance.....	Pages 35-38
Troubleshooting.....	Page 39
Repair Parts.....	Pages 40-42
Sears Repair Parts Phone Numbers.....	Back Cover

### ONE YEAR FULL WARRANTY ON CRAFTSMAN PRODUCT

If this Craftsman product fails due to a defect in material or workmanship within one year from the date of purchase **RETURN IT TO THE NEAREST SEARS STORE OR PARTS AND REPAIR CENTER OR OTHER CRAFTSMAN OUTLET IN THE UNITED STATES FOR FREE REPAIR** (or replacement if repair proves impossible).

This warranty does not include expendable parts such as lamps, batteries, bits or blades.

If this Craftsman product is used for commercial or rental purposes, this warranty applies for only 90 days from the date of purchase.

This warranty gives you specific legal rights, and you may also have other rights which vary from state to state.

Sears, Roebuck and Co., Hoffman Estates, IL 60179

**SAVE THESE INSTRUCTIONS!  
READ ALL INSTRUCTIONS!**

## SAFETY SYMBOLS

The purpose of safety symbols is to attract your attention to possible dangers. The safety symbols, and the explanations with them, deserve your **careful attention and understanding**. The symbol warnings **DO NOT** by themselves eliminate any danger. The instructions and warnings they give are no substitutes for proper accident prevention measures.

**⚠ WARNING: BE SURE to read and understand all safety instructions in this manual, including all safety alert symbols such as "DANGER", "WARNING" and "CAUTION", BEFORE using this saw. Failure to follow all instructions listed below may result in electric shock, fire and/or serious personal injury.**

### SYMBOL MEANING

**⚠ SAFETY ALERT SYMBOL:** Indicates DANGER, WARNING, OR CAUTION. May be used in conjunction with other symbols or pictographs

**⚠ DANGER** Failure to obey this safety warning **WILL** result in death or serious injury to yourself or to others. Always follow the safety precautions to reduce the risk of fire, electric shock and personal injury.

**⚠ WARNING** Failure to obey this safety warning **CAN** result in death or serious injury to yourself or to others. Always follow the safety precautions to reduce the risk of fire, electric shock and personal injury.

**⚠ CAUTION** Failure to obey this safety warning **MAY** result in personal injury to yourself or others or property damage. Always follow the safety precautions to reduce the risk of fire, electric shock and personal injury.

### DAMAGE PREVENTION AND INFORMATION MESSAGES

These inform user of **important information and/or instructions** that could lead to equipment or other property damage if not followed. Each message is preceded by the word **"NOTE:"** as in the example below:

**NOTE: Equipment and/or property damage may result if these instructions are not followed.**



**⚠ WARNING:** The operation of any tool with a circular blade can result in foreign objects being thrown into your eyes, which can result in severe eye damage. Before beginning power tool operation, **ALWAYS** wear safety goggles or safety glasses with side shield and a full-face shield when needed. We recommend a Wide Vision Safety Mask for use over eyeglasses or standard safety glasses with side shield, available at Sears Stores or other Craftsman Outlets.

## SAFETY INSTRUCTIONS

**⚠ WARNING: BE SURE to read and understand all instructions in this manual before using the miter saw. Failure to follow all instructions may result in hazardous radiation exposure, electric shock, fire and/or serious personal injury.**

### SAFETY PRECAUTIONS FOR LASERS

This miter saw has a built-in laser light. The laser is a Class IIIa and emits output power of a maximum 2.5mW and 635-665nm wavelengths. These lasers do not normally present an optical hazard. However, **DO NOT** stare at the beam as this can cause flash blindness.

**CAUTION:** The following label is on your tool. It indicates where the saw emits the laser light. **BE AWARE** of the laser light location when using. **ALWAYS MAKE SURE** that any bystanders in the vicinity of use are made aware of the dangers of looking directly into the laser.

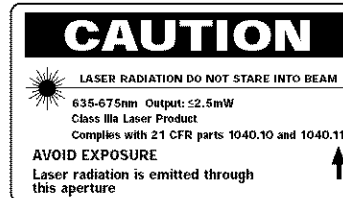

**⚠ WARNING: LASER LIGHT. LASER RADIATION. Avoid Direct Eye Exposure. DO NOT** stare into beam. Only turn laser beam on when the saw is on the workpiece. Class IIIa laser.

**⚠ WARNING: Use of controls, adjustments or performance of procedures other than those specified in this manual may result in hazardous radiation exposure.**

**⚠ WARNING: The use of optical instruments such as, but not limited to, telescopes or transits to view the laser beam will increase eye hazard.**

1. **DO NOT** remove or deface any product labels. Removing product labels increases the risk of exposure to laser radiation.
2. The laser beam can be harmful to the eyes. **ALWAYS** avoid direct eye exposure. **DO NOT** look directly into the laser beam output aperture during operation. **DO NOT** project the laser beam directly into the eyes of others. Turn laser on **ONLY** when making cuts.
3. The laser on the miter saw is not a toy. **ALWAYS** keep out of the reach of children. The laser light emitted from this device **SHOULD NEVER** be directed towards any person for any reason.
4. **BE SURE** the laser beam is aimed at a workpiece (such as wood or rough coated surfaces) that does not have a reflective surface.
5. **DO NOT** use on surfaces such as sheet steel that have a shiny, reflective surface. The shiny surface could reflect the beam back at the operator. Be aware that laser light reflected off of a mirror or any other reflective surfaces can also be dangerous.
6. **ALWAYS** turn the laser beam off when not in use. Leaving the tool on increases the risk of someone inadvertently staring into the laser's beam.

**⚠ CAUTION: ALWAYS follow only the instructions contained in this manual when using this laser. Use of this feature in any manner other than what appears in this manual may result in a hazardous radiation exposure.**

## SAFETY INSTRUCTIONS cont.

### SAFETY PRECAUTIONS FOR LASERS cont.

7. **DO NOT** attempt to modify the performance of this laser device in any way. This may result in a dangerous exposure to laser radiation.
8. **ALWAYS** use only the accessories that are recommended by Sears for use with this product. Use of accessories that have been designed for use with other laser tools could result in serious injury.
9. For further information regarding lasers, refer to ANSI-Z136.1 The STANDARD FOR THE SAFE USE OF LASERS, available from the Laser Institute of America (407) 380-1553.

### WORK AREA SAFETY

1. **Keep your work area clean and well lit. DO NOT** leave tools or wood scraps on the saw while it is in operation. Cluttered workbenches and dark areas invite accidents.
2. **DO NOT operate power tools in explosive atmospheres, such as in the presence of flammable liquids, gases, or dust.** Power tools create sparks which may ignite the dust or fumes.
3. **ALWAYS keep bystanders, children and visitors away while operating a power tool.** Distractions can cause you to lose control.
4. **Make your workshop childproof** with padlocks and master switches. Lock tools away when not in use.
5. **MAKE SURE the work area has ample lighting** so you can see the work and that there are no obstructions that will interfere with safe operation **BEFORE** using your saw.

### PERSONAL SAFETY

1. **KNOW your power tool.** Read the operator's manual carefully. Learn the saw's applications and limitations, as well as the specific potential hazards related to this tool.
2. **STAY ALERT,** watch what you are doing and use common sense when operating a power tool.
3. **DO NOT** use tool while tired or under the influence of drugs, alcohol or medication. A moment of inattention while operating power tools may result in serious personal injury.
4. **DRESS properly. DO NOT** wear loose clothing or jewelry. Pull back long hair. Keep your hair, clothing, and gloves away from moving parts. Loose clothing or long hair can be caught in moving parts. Air vents often cover moving parts and should also be avoided.
5. **AVOID** accidental starting. Be sure switch is in "OFF" position before plugging in.
6. **REMOVE** adjusting keys or blade wrenches before turning the tool "ON". A wrench that is left attached to a rotating part of the tool may result in personal injury.
7. **DO NOT overreach. Keep proper footing and balance at all times.** Proper footing and balance enables better control of the tool in unexpected situations.

## SAFETY INSTRUCTIONS cont.

### PERSONAL SAFETY cont.

8. **ALWAYS SECURE YOUR WORK.** Use clamps or a vise to hold work when practical. It is safer than using your hand and frees both hands to operate tool.
9. **USE SAFETY EQUIPMENT.** Always wear eye protection. Dust mask, non-skid safety shoes, hard hat, or hearing protection must be used for appropriate conditions.
10. **NEVER stand on tool.** Serious injury could occur if the tool is tipped or if the blade is accidentally contacted.

### TOOL USE AND CARE SAFETY

**⚠ WARNING: BE SURE to read and understand all instructions before operating this saw. Failure to follow all instructions listed below may result in electric shock, fire and/or serious personal injury.**

1. **ALWAYS use clamps or other practical ways to secure and support the workpiece to a stable platform.** Holding the work by hand or against your body is unstable and may lead to loss of control.
2. **DO NOT force the tool. Use the correct tool and blade for your application.** The correct tool and blade will do the job better and safer at the rate for which it is designed.
3. **DO NOT use the tool if switch does not turn it "On" or "Off".** Any tool that cannot be controlled with the switch is dangerous and must be repaired.
4. **DISCONNECT the plug from the power source before making any adjustments, changing accessories or storing the tool.** Such preventive safety measures reduce the risk of starting the tool accidentally.
5. **NEVER leave the tool running unattended. ALWAYS turn it off. DO NOT leave until the tool comes to a complete stop.**
6. **STORE idle tools out of the reach of children and other untrained persons.** Tools are dangerous in the hands of untrained users.
7. **MAINTAIN tools with care. Keep cutting tools sharp and clean.** Properly maintained tools with sharp cutting edges are less likely to bind and are easier to control.
8. **CHECK for misalignment or binding of moving parts, breakage of parts, and any other condition that may affect the tool's operation.** If damaged, have the tool serviced before using. Many accidents are caused by poorly maintained tools.
9. **USE ONLY accessories that are recommended for this tool.** Accessories that may be suitable for one tool may become hazardous when used on another tool.
10. **NEVER cut metals or masonry products with this tool.** This miter saw is designed for use **ONLY** on wood and wood-like products.
11. **KEEP blade guards in place and in good working order.**

## SAFETY INSTRUCTIONS cont.

### ELECTRICAL SAFETY

**⚠ WARNING: Do not permit fingers to touch the terminal or plug when installing or removing the plug from an outlet.**

1. **Double insulated tools are equipped with a polarized plug (one blade is wider than the other). This plug will fit in a polarized outlet only one way.** If the plug does not fit fully in the outlet, reverse the plug. If it still does not fit, contact a **qualified electrician** to install a polarized outlet. Do not change the plug in any way.
2. Double insulation  eliminates the need for the three-wire grounded power cord and grounded power supply system. Applicable only to Class II (double-insulated) tools. This compound miter saw is a double insulated tool.

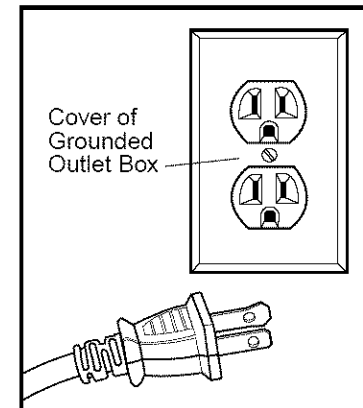

**⚠ WARNING: Double insulation DOES NOT take the place of normal safety precautions when operating this tool.**

3. **BEFORE** plugging in the tool, **BE SURE** that the outlet voltage supplied is within the voltage marked on the tool's data plate. **DO NOT** use "AC only" rated tools with a DC power supply.
4. **AVOID body contact with grounded surfaces**, such as pipes, radiators, ranges and refrigerators. There is an increased risk of electric shock if your body is grounded.
5. **DO NOT expose power tools to rain or wet conditions or use power tools in wet or damp locations.** Water entering a power tool will increase the risk of electric shock. This tool is intended for indoor use only.
6. **If operating a power tool in damp locations is unavoidable, ALWAYS USE a Ground Fault Circuit Interrupter to supply power to your tool. ALWAYS WEAR electrician's rubber gloves and footwear in damp conditions.**
7. **INSPECT tool cords for damage.** Have damaged tool cords repaired at a Sears Service Center. **BE SURE** to stay constantly aware of the cord location and keep it well away from the moving blade.
8. **DO NOT abuse the cord. NEVER use the cord to carry the tool by or to pull the plug from the outlet.** Keep cord away from heat, oil, sharp edges or moving parts. Replace damaged cords immediately. Damaged cords increase the risk of electric shock.

## SAFETY INSTRUCTIONS cont.

### EXTENSION CORDS

Use a proper extension cord. **ONLY** use cords listed by Underwriters Laboratories (UL). Other extension cords can cause a drop in line voltage, resulting in a loss of power and overheating of tool.

For this tool an AWG (American Wire Gauge) size of a least 14-gauge is recommended for an extension cord of 25- ft. or less in length. Use 12-gauge for an extension cord of 50-ft. **Extension cords 100-ft. or longer are not recommended.**

Remember, a smaller wire gauge size has greater capacity than a larger number (14-gauge wire has more capacity than 16-gauge wire; 12-gauge wire has more capacity than 14-gauge). When in doubt use the smaller number.

When operating a power tool outdoors, use an outdoor extension cord marked "W-A" or "W". These cords are rated for outdoor use and reduce the risk of electric shock.

**⚠ CAUTION:** Keep the extension cord clear of the working area. Position the cord so that it will not get caught on lumber, tools or other obstructions while you are working with a power tool.

**⚠ WARNING:** Check extension cords before each use. If damaged replace immediately. Never use tool with a damaged cord since touching the damaged area could cause electrical shock, resulting in serious injury.

## SAFETY SYMBOLS FOR YOUR TOOL

The label on your tool may include the following symbols.

V	Volts
A	Amps
Hz	Hertz
W	Watts
min	Minutes
~	Alternating Current
—	Direct Current
n <sub>o</sub>	No-load Speed
□	Class II construction
.../min	Revolutions or Strokes per minute
⚠	Indicates danger, warning caution. It means attention! Your safety is involved.

## SAFETY INSTRUCTIONS cont.

### SERVICE SAFETY

1. If any part of this saw is missing or should break, bend, or fail in any way; or should any electrical component fail to perform properly: **SHUT OFF** the power switch and remove the saw plug from the power source and have the missing, damaged or failed parts replaced **BEFORE** resuming operation.
2. **Tool service must be performed only at a Sears Parts and Repair Center.** Service or maintenance performed by unqualified personnel could result in a risk of injury.
3. **When servicing a tool, use only identical replacement parts. Follow instructions in the maintenance section of this manual.** Use of unauthorized parts or failure to follow maintenance instructions may create a risk of electric shock or injury

### SAFETY RULES FOR MITER SAWS

1. **Know your power tool. Read operator's manual carefully. Learn the applications and limitations, as well as the specific potential hazards related to this tool.** Following this rule will reduce the risk of electric shock, fire or serious injury.
2. **ALWAYS firmly clamp or bolt your miter saw** to a secure, stable workbench or table at approximately hip height.
3. **BE SURE that all adjustments are secure BEFORE making a cut.**
4. **ALWAYS** make sure that the miter table and saw arm (bevel function) are locked in position **BEFORE** operating your saw. Lock the miter table by securely tightening the miter lock lever. Lock the saw arm (bevel function) by securely tightening the bevel lock knob.
5. **USE the hold down clamp (included) to secure the workpiece, WHENEVER possible.**
6. **BE SURE that the blade path is free of nails. ALWAYS** carefully inspect lumber and remove all nails **BEFORE** cutting.
7. **ALWAYS be sure that the blade clears the workpiece. NEVER start the saw with the blade touching the workpiece. ALWAYS** allow the motor to come up to full speed **BEFORE** starting a cut.
8. **SUPPORT long workpieces when cutting to minimize the risk of blade pinching or kickback.** The saw may slip, walk or slide while cutting long or heavy boards.
9. **NEVER** use a length-stop on the free (scrap end) of a clamped workpiece, **NEVER** hold onto or bind the free scrap end of the workpiece in any operation. If a work clamp and length stop are used together, **THEY MUST BOTH BE INSTALLED** on the **SAME SIDE** of the saw table to prevent the saw from catching the loose end and kicking up.
10. **NEVER cut more than one piece at a time. DO NOT STACK more than one workpiece on the worktable at a time.**
11. **AVOID** awkward operations and hand positions where a sudden slip could cause your hand to move into the blade. **ALWAYS** make sure that you have good balance. **NEVER** operate your saw on the floor or in a crouched position.
12. **NEVER** stand or have any part of your body in line with the path of the blade.

## SAFETY INSTRUCTIONS cont.

### SAFETY RULES FOR MITER SAWS cont.

13. **ONLY USE the correct blades.** Use the right blade size, style and cutting speed for the material and the type of cut. **DO NOT** use blades with incorrect size holes. **NEVER** use blade washers or blade bolts that are defective or incorrect. The maximum blade capacity for this saw is 7 1/4-inches.
14. **ALWAYS keep blades clean, sharp and with the sufficient set.** Sharp blades minimize stalling and kickback.
15. **DO NOT use dull or damaged blades.** Bent blades can break easily, or cause kickback.
16. **DO NOT remove the saw's blade guards. NEVER operate the saw with any guard or cover removed. MAKE SURE** that all guards are operating properly **BEFORE** each use.
17. **NEVER hand hold a workpiece that is too small to be clamped. ALWAYS keep your hands clear of the "no hands" zone.**
18. **NEVER perform any operation freehand. ALWAYS** place the workpiece to be cut on the miter saw table and position it firmly against the fence as a backstop. **ALWAYS** use the fence.
19. **NEVER** apply lubricants to the blade when it is running. **NEVER** use solvents to clean plastic parts. Solvents could possibly dissolve or otherwise damage the material.
20. **KEEP YOUR HANDS AWAY from the cutting area. DO NOT** reach under the material being cut or in the blade's cutting path with your fingers or hand **for any reason. ALWAYS** turn the power **off**.

**⚠ WARNING: Blade continues to turn after power to saw cuts off. To avoid possible serious injury, after releasing trigger switch to cut power, allow the saw blade to stop rotating BEFORE raising the blade out of the workpiece.**

21. **NEVER reach behind, under or within three inches of the blade** and its cutting path with your hands or fingers **for any reason.**
22. **NEVER, for any reason, touch the blade or other moving parts during use.**
23. **DO NOT turn the motor switch on and off rapidly.** This could cause the blade to loosen, which could create a hazard. Should this ever occur, stand clear and allow the saw blade to come to a complete stop. **Disconnect the saw** from the power source and securely tighten the blade bolt.
24. **ALWAYS turn off the saw** before disconnecting it to avoid accidental starting when reconnecting the saw to a power supply. **NEVER** leave the saw unattended while connected to a power supply.
25. **KEEP THE MOTOR AIR SLOTS** clean and free of chips or dust. To avoid motor damage, the motor should be blown out or vacuumed frequently to keep sawdust from interfering with the motor ventilation.
26. **NEVER lift this tool by gripping the cutting handle or the miter fence. This may cause misalignment. ALWAYS carry saw by holding the base or carry by the support bracket/carrying handle after you have locked the saw arm in the "DOWN" position.**

## SAFETY INSTRUCTIONS cont.

### SAFETY RULES FOR MITER SAWS cont.

**⚠ WARNING: Use of this product can generate dust containing chemicals known to cause cancer birth defects or other reproductive harm.**

**Some examples of these chemicals are:**

- Lead from lead-based paints.
- Crystalline silica from bricks and cement and other masonry products.
- Arsenic and chromium from chemically-treated lumber.

**Your risk from these exposures varies, depending upon how often you do this type of work. To reduce your exposure to these chemicals:**

- Work in a well-ventilated area.
- Work with approved safety equipment, such as those dust masks that are specially designed to filter out microscopic particles.

### ADDITIONAL RULES FOR SAFE OPERATION

**⚠ WARNING: Use of this tool can generate and/or disburse dust, which may cause serious and permanent respiratory or other injury. Always use NIOSH/OSHA approved respiratory protection appropriate for the dust exposure. Direct particles away from face and body.**

1. **Know your power tool. Read operator's manual carefully. Learn the applications and limitations, as well as the specific potential hazards related to this tool.** Following this rule will reduce the risk of electric shock, fire or serious injury.
2. **ALWAYS wear safety glasses or eye shields when using this saw.** Everyday eyeglasses have only impact-resistant lenses; they are **NOT** safety glasses. **All users and bystanders MUST** wear eye protection that conforms to ANSI Z87.1
3. **PROTECT your lungs.** Wear a face mask or dust mask if the operation is dusty.
4. **PROTECT your hearing.** Wear appropriate personal hearing protection during use. Under some conditions and duration of use, noise from this product may contribute to hearing loss.
5. **ALL VISTORS AND BYSTANDERS MUST** wear the same safety equipment that the operator of the saw wears.
6. **INSPECT** the tool cords periodically and if damaged have them repaired at your nearest Sears Service Center or other Authorized Service Facility. **BE AWARE** of the cord location when operating the saw.
7. **ALWAYS check the tool for damaged parts.** Before further use of the tool, a guard or other part that is damaged should be carefully checked to determine if it will operate properly and perform its intended function. Check for misalignment or binding of moving parts, breakage of parts, and any other condition that may affect the tool's operation. A guard or other part that is damaged should be properly repaired or replaced at a Sears Service center.
8. **INSPECT and remove all nails from lumber before sawing.**
9. **SAVE THESE INSTRUCTIONS.** Refer to them frequently and use them to instruct others who may use this tool. If someone borrows this tool, make sure they have these instructions also.

## GLOSSARY OF TERMS FOR WOODWORKING

### **Arbor**

The revolving shaft on which a blade or cutting tool is mounted.

### **Arbor Lock**

Allows the user to stop blade from rotating while tightening or loosening the arbor screw during blade replacement or removal.

### **Revolutions Per Minute (RPM)**

The number of turns completed by a spinning object in one minute.

### **No Hands Zone**

The area between the marked lines on the left and right side of the miter table base. This zone is identified by no hands zone symbols inside the marked lines on the miter table base.

### **Throat Plate**

A plastic throat plate inserted in the miter saw's table that allows for blade clearance.

### **Saw Blade Path**

The area over, under, behind or in front of the blade, as it applies to the workpiece. That area which will be or has been cut by the blade.

### **Set**

The distance that the saw blade tooth is bent (or set) outward from the face of the blade.

### **Miter Cut**

A cutting operation made with the blade at any angle other than 90° to the fence.

### **Compound Miter Cut**

A compound miter cut is a cut made using a miter angle and a bevel angle at the same time.

### **Cross cut**

A cutting or shaping operation made against the grain of the workpiece.

### **Bevel Cut**

A cutting operation made with the blade at any angle other than 90° to the miter table.

### **Dado Cut**

A non-through cut which produces a square-sided notch or trough in the workpiece (requires special blade).

## GLOSSARY OF TERMS FOR WOODWORKING cont.

### **Chamfer Cut**

A cut removing a wedge from a block of wood so the end (or part of the end) is angled at other than 90°.

### **Ripping or Rip Cut**

A cutting operation along the length of the workpiece.

### **Freehand Cut**

Performing a cut without using a fence, miter gauge, fixture, work clamp, or other proper device to keep the workpiece from twisting or moving during the cut.

### **Through Sawing**

Any cutting operation where the blade extends completely through the thickness of the workpiece.

### **Non-Through Cuts**

Any cutting operation where the blade does not extend completely through the thickness of the workpiece.

### **Kerf**

The material removed by the blade in a through cut or the slot produced by the blade in a non-through or partial cut.

### **Kickback**

A hazard that can occur when the blade binds or stalls, throwing the workpiece back toward operator.

### **Workpiece or Material**

The item on which the cutting operation is being done. The surfaces of a workpiece are commonly referred to as faces, ends and edges.

### **Gum**

A sticky, sap-based residue from wood products.

### **Resin**

A sticky, sap-based substance that has hardened.

## UNPACKING

**⚠ WARNING:** Your saw should NEVER be connected to the power source when you are assembling parts, making adjustments, installing or removing blades, cleaning or when it is not in use. Disconnecting the saw will prevent accidental starting, which could cause serious personal injury.

1. Open the carton and remove the saw by lifting it out by its base, with a hand on each side. **IMPORTANT: DO NOT LIFT THE MITER SAW** by the cutting handle as this will cause misalignment of the saw arm to the saw base. **ALWAYS** lift and carry (transport) the miter saw by its base! There is also a support bracket/carrying handle on back of the saw (Page 17 Fig. 1b) which can also be used in transporting the saw. Pull the support bracket/carrying handle out as far as it will extend and use to carry saw.
2. After lifting saw out of the carton, place it on a flat stable work surface with sufficient space to inspect your saw.
3. The miter saw has been shipped with the saw arm locked in the **DOWN** position. To release the saw arm, hold down slightly on the top of the saw arm and pull out the locking pin (see illustration below). The saw arm is spring operated, so hold the arm and let it raise slowly. The saw arm will pull up on its own and stay in the up position to allow for easy placement of material in the cutting area. When saw is not in use, saw arm should be locked in the down position.
4. To lock the saw arm for transporting and storage, press and hold down the saw arm to the lowest position, then push locking pin back in.
5. Inspect the saw carefully to make sure that no breakage or damage has occurred during shipping.
6. Check to make certain all parts are accounted for (refer to illustration below). If any of the items listed are missing, or any breakage or damage has occurred, return the saw to your nearest Sears store or Craftsman outlet to have the saw replaced.

**⚠ WARNING:** If any parts are broken or missing, **DO NOT** attempt to assemble the miter saw, plug in the power cord, or operate saw until the broken or missing parts are replaced. Failure to do so could result in possible serious injury.

### CARTON CONTENTS / LOOSE PARTS LIST

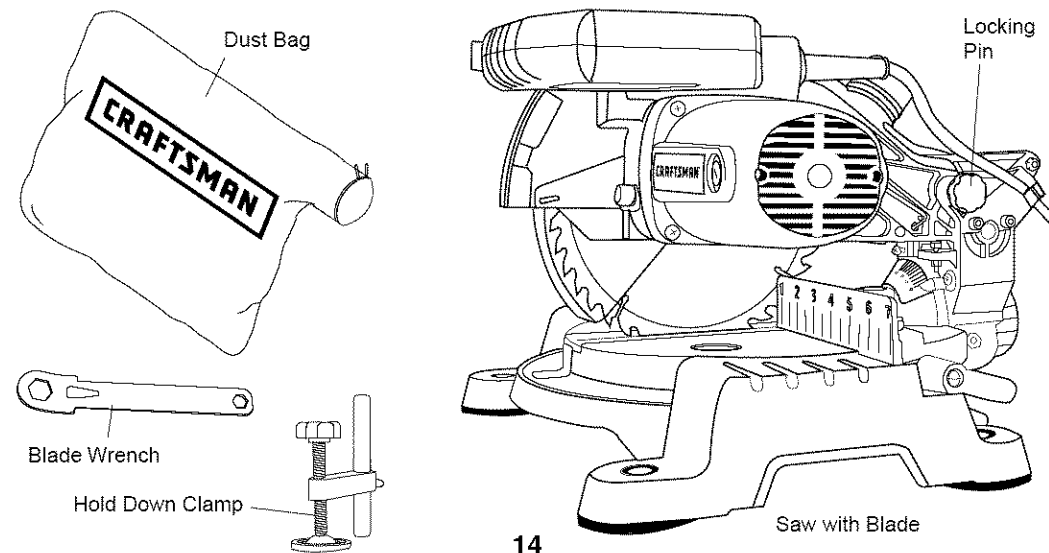

## DESCRIPTION

### KNOW YOUR MITER SAW (Fig. 1a & 1b)

**NOTE:** Before attempting to use your saw, familiarize yourself with all of the operating features and safety requirements.

Your miter saw has a precision-built electric motor and it should only be connected to a 120-volt, 60-Hz AC ONLY power supply (normal household current). **DO NOT** operate on direct current (DC). The large voltage drop would cause a loss of power and the motor would overheat. If the saw does not operate when plugged into correct 120-volt, 60-Hz AC ONLY outlet, check the power supply. The saw comes with a 6-ft. power cord (no adapter needed).

### This Compound Miter Finishing Saw has the following features:

1. **9.0 Amp, 5000 RPM (no-load speed) motor.** Provides power and torque for fast, 90° cross cuts, 45° miter, bevel and compound cuts in decorative wood moldings such as chair rail, cove, shoe and baseboard, and cuts 2 X 4's with ease.
2. **Easy-to-read bevel and miter scales.** Positive miter stops at 0°, 15°, 22.5°, 30°, and 45° left and right for exact miter cuts.
3. **Ergonomically designed handle** with molded-in comfort grip for maximum control and comfortable hand support when cutting.
4. **Includes Craftsman® 7 1/4-in., 40 tooth, thin kerf steel blade, Carbide tipped** for smooth cutting in all woods and wood base materials. 5/8-in arbor. Arbor lock for quick, easy blade changes.
5. **Die-cast aluminum upper blade guard, table, fence and base** are lightweight and durable. Saw weighs only 16-lbs., one of the lightest, most compact miter saws on the market.
6. **Durable high-impact plastic lower blade guard** allows view of workpiece and laser cutting line.
7. **Sawdust ejection port** hooks up to dust bag (included) or a 1 1/4-in. hose adapter for a wet/dry vac (sold separately).
8. **Easy-to-use knob and lever** for quick miter, bevel and compound miter adjustments, no tools needed.
9. **Project ruler etched on right fence** for quick reference; 1 to 7 inches in 1/8-in increments.
10. **Permanently lubricated 100% ball bearings** for long tool life and smooth operation.

**⚠ WARNING:** **DO NOT** allow familiarity with your saw to make you careless. Remember that a careless fraction of a second is sufficient to inflict serious injury.

11. **Saw arm locking pin** locks saw arm in **DOWN** position when pushed in. Pull locking pin out to release saw arm.
12. **Arbor lock button** stops arbor from rotating for easy blade changes.

14

15

**DESCRIPTION cont.**

**KNOW YOUR MITER SAW (Fig. 1a and 1b) cont.**

**Fig. 1a**

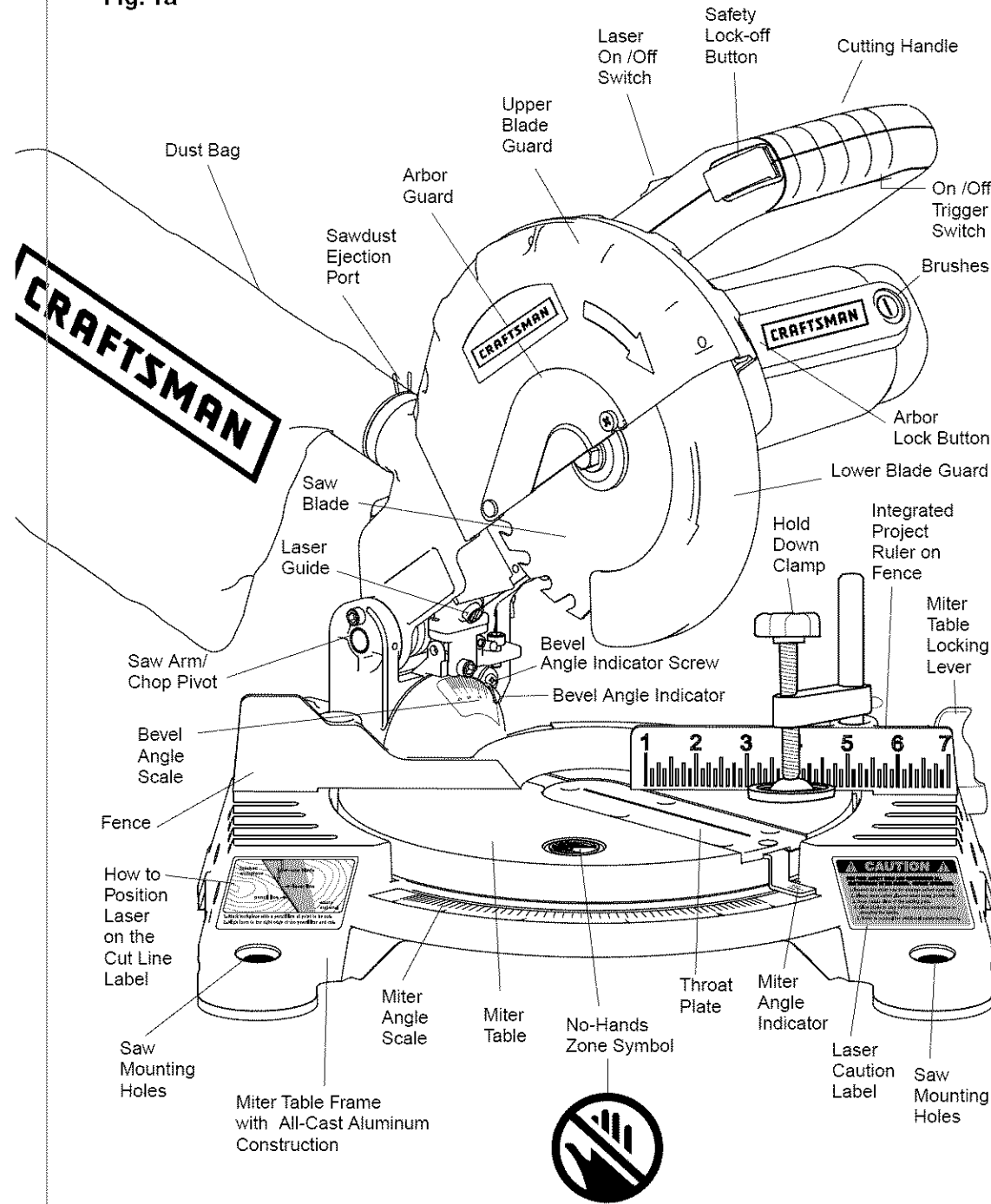

**DESCRIPTION cont.**

**KNOW YOUR MITER SAW (Fig. 1a and 1b) cont.**

**Fig. 1b**

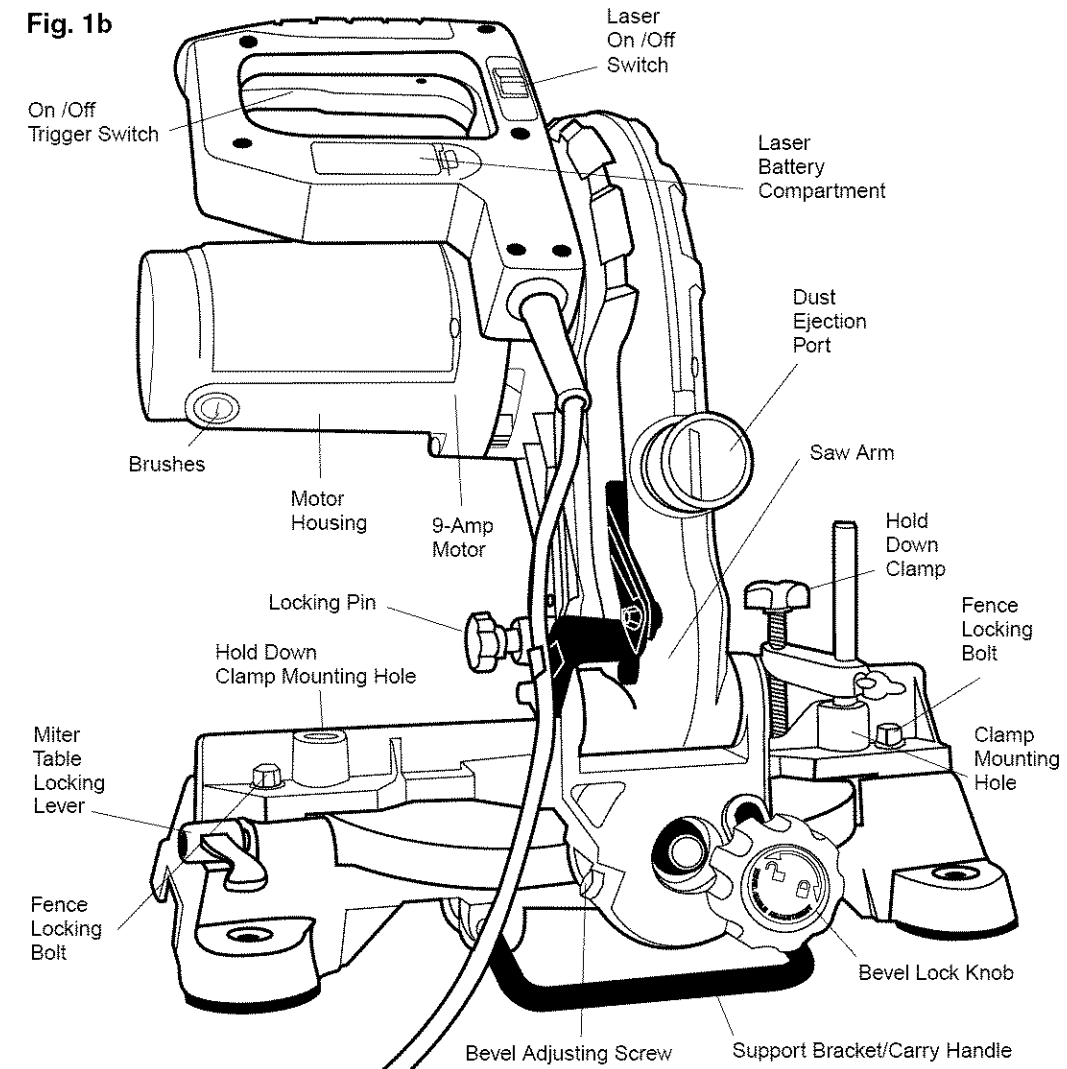

PRODUCT SPECIFICATIONS		CUTTING CAPACITIES				
Supply power	120V, 60Hz	Type of cut	Angle Setting		Maximum	
Rated current	9A		Miter	Bevel	Thickness	Width
No load speed	5000RPM±10%	Cross cut	0°	0°	2-in.	4 1/4-in.
Saw blade size	7 1/4-in. x 5/8-in. x 1/16-in. 40T	Miter cut	45°	0°	2-in.	4 1/4-in.
Miter angle	45° left to 45° right	Bevel cut	0°	45°	1 1/2-in.	4-in.
Bevel angle	45° left to 0°	Compound cut	45°	45°	1 1/2-in.	3 1/2-in.

**NOTE:** Cutting specifications will vary by the blade type used, actual lumber size, and compound miter saw. All dimensions are approximate.



## DESCRIPTION cont.

### KNOW YOUR MITER SAW (Fig. 1a and 1b) cont.

#### Laser On/Off Switch

To turn on laser, push the laser switch to "On"

#### On/Off Trigger Switch and Safety Lock-Off Button

To turn on saw, push safety lock button in with thumb while squeezing the On/Off Trigger Switch located under the handle (Fig. 1b). To shut off saw, simply release both.

#### Easy-to-read miter and bevel scales:

Miter angle scale marked in 1/2° increments, emphasis on every 5°, from 0° to 45° left and right. Positive miter stops at 0°, 15°, 22.5°, 30°, and 45° for exact cuts.

Bevel angle scale marked in 1° increments, emphasis on every 5°, from 0° to 45° left with 33.9° marked.

#### Miter Table Locking Lever

The miter table locking lever locks the saw table at the desired miter angle, 0° to 45° left or right. The table turns left or right by releasing the miter lock lever and moving the base of the cutting assembly (which moves the miter table) while holding the miter table frame secure.

#### Bevel Lock Knob

The bevel lock knob securely locks your compound miter saw at the desired bevel angles. To loosen the knob, turn counterclockwise and tilt the saw head to set to the desired angle as shown on the bevel scale. The blade can be positioned at any angle, from a 90° straight cut (0° on the scale) to a 45° left bevel (Fig. 1b). Tighten the bevel lock knob to secure the saw head.

#### Miter Fence

The miter fence is in two pieces, with a numbered ruler on the right side and a slightly taller left side for additional support. Hold the workpiece securely against the miter fence when making all cuts. Use the hold down clamp to secure the workpiece whenever possible.

#### Self-Retracting Lower Blade Guard

The lower blade guard is made of shock-resistant, see-through plastic and it provides protection from each side of the blade. It retracts over the upper blade guard as the blade is lowered into the workpiece.

#### Hold Down Clamp

Mounts on left or right side of fence to securely clamp workpiece.

#### Carrying Handle/Support Bracket

Use to carry and transport saw. Also stabilizes the saw (front to back) on flat surface.

## ASSEMBLY

### MOUNTING THE MITER SAW TO WORK SURFACE (Fig. 2 and 2a)

To prevent your miter saw from sliding, falling or tipping during operation, the saw must be permanently mounted to a firm, stable supporting surface, such as a workbench or piece of plywood.

Four bolt holes have been provided in the saw base (one in each corner) for mounting purposes. Each of these four mounting holes should be securely bolted using 3/8-in. machine bolts, lock washers and hex nuts (not included). Bolts should be long enough to fit through the saw base, lock washers, hex nuts and the thickness of the workbench or plywood.

Tighten all four bolts securely. Position the saw and workbench to allow adequate room for crosscutting long workpieces. The hole pattern for an 18-in. x 24-in. workbench is shown in Fig. 2. Carefully check the workbench after mounting the saw to make sure that no movement can occur during use. If any tipping, sliding or walking is noted, secure the workbench to the floor before operating. If mounting miter saw to plywood, be sure to clamp plywood to worktable or bench or place plywood on a flat stable surface before operating saw Fig. 2a.

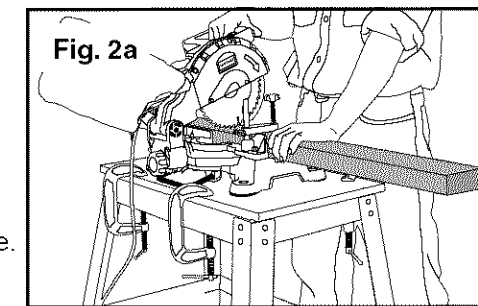
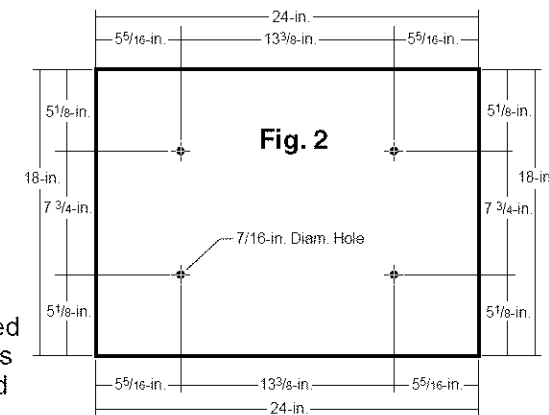

**⚠ CAUTION:** To reduce the risk of injury, always unplug tool before attaching or removing accessories or making adjustments. Use only specifically recommended accessories. Others may be hazardous.

### SAWDUST EJECTION PORT

This miter saw comes with a dust bag to help you keep the work area clean. The dust bag is ideal for smaller jobs.

Use a 1 1/4-in. vac hose adapter (available at Sears stores and other Craftsman outlets) to hook up your saw to a wet/dry vac (sold separately).

To install dust bag squeeze the metal collar wings located at the opening of the dust bag. Place the dust bag neck opening around the sawdust ejection port (located on saw arm, behind upper blade guard) (Fig. 3) and then release the metal collar wings. (Fig. 3a).

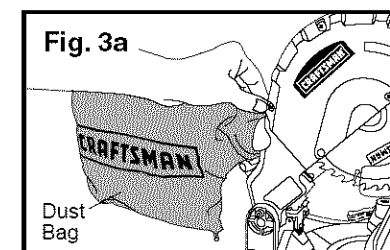
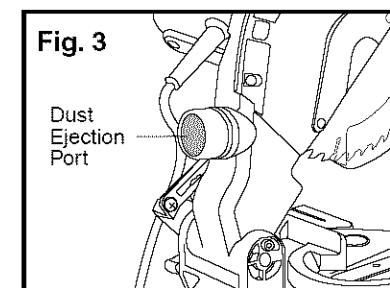

## ADJUSTMENTS

### SQUARING THE BLADE TO THE FENCE (Fig. 4)

**⚠ WARNING:** Failure to unplug your saw could result in accidental starting causing serious injury.

1. Set the bevel and miter angles to 0° degrees.
2. Lower and lock the saw arm into the "DOWN" position.
3. Using a square, lay the heel of the square against the blade, and the rule of the square against the fence.

**NOTE:** Be sure to rest the square against the body of the blade and not against the teeth of the blade.

4. If the blade is not 90° to the fence, loosen the two fence locking bolts. Adjust the fence 90° to the blade. When blade is 90° square to fence, re-tighten the two fence locking bolts. Use a 6 mm. Hex Key to loosen and tighten the fence locking bolts.

**NOTE:** If the saw has not been used recently, recheck blade squareness to the fence and readjust if necessary.

### MITER ANGLE INDICATOR ADJUSTMENT (Fig. 5) If Necessary

**⚠ WARNING:** Failure to unplug your saw could result in accidental starting causing serious injury.

1. Place the miter table at 0° and lock in place.
2. Loosen the miter angle indicator screw and adjust the indicator to the "0" mark on the miter scale (Fig.5).
3. Tighten the miter angle indicator screw.

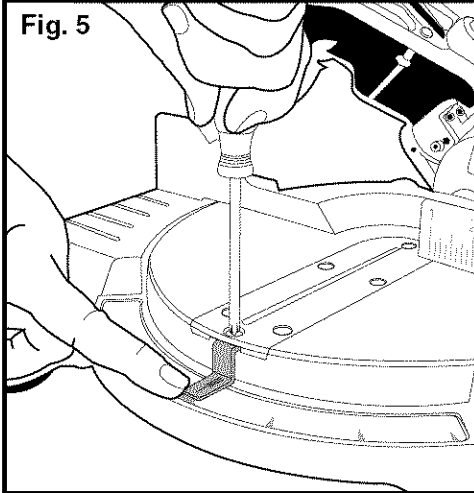
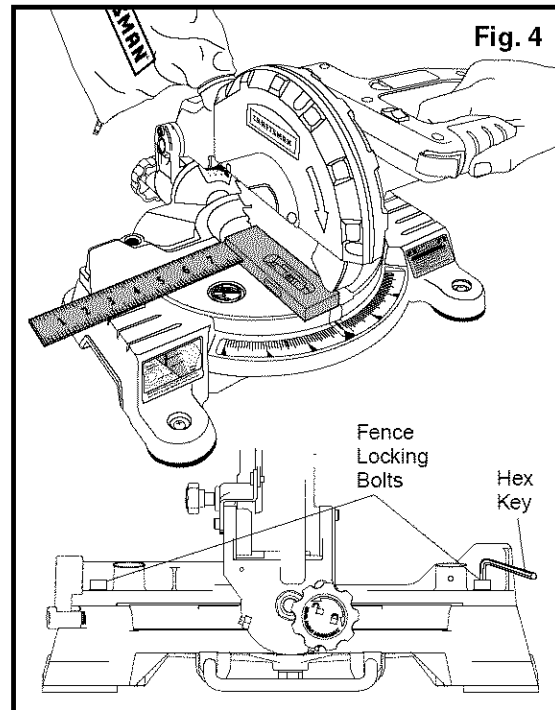

## ADJUSTMENTS cont.

### SQUARING THE BLADE TO THE MITER TABLE 0° Bevel, 0° Miter (Fig. 6)

**⚠ WARNING:** Failure to unplug your saw could result in accidental starting causing serious injury.

1. Set the bevel and miter angle scales to 0° and lock in place.
2. Lower and lock the saw arm into the "DOWN" position.
3. Place a combination square on the miter table with the rule against the table and heel of the square against the saw blade.

**NOTE:** Be sure to rest the square against the body of the blade and not against the teeth of the blade.

4. If the blade is not 90° square with the miter table, perform steps 5 through 8.
5. Loosen locknut "A" with a 10 mm wrench (This is the **outer** part of the bevel angle screw "A"). **This screw is to your left as you face the back of the saw.**
6. Loosen bevel lock knob, then square the blade to the table by adjusting the set screw (**inside** of bevel angle screw "A") clockwise or counterclockwise with a 3 mm hex key. You may have to move the saw arm by hand. It may help to hold the lock nut in place with the wrench, while turning the set screw.
7. Once the angle is set, tighten the lock nut with the wrench while holding the set screw in place with the hex key.
8. Lock the bevel knob.

### BEVEL ANGLE INDICATOR ADJUSTMENT (Fig. 6a) If Necessary

1. Check to see if the bevel angle indicator is pointing to 0° on the bevel scale.
2. If the indicator is not on 0°, loosen the bevel angle indicator screw, adjust the indicator to 0° on bevel angle scale, tighten screw.

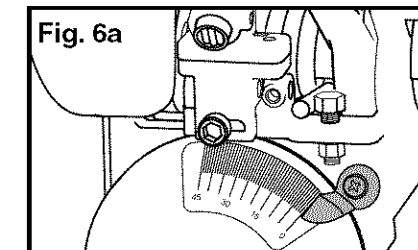
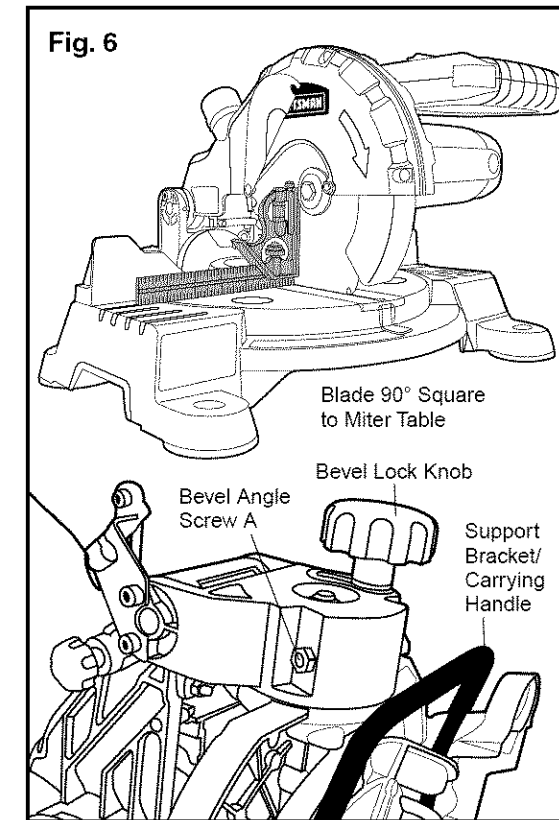

## ADJUSTMENTS cont.

### THROAT PLATE SLOT (Fig. 7)

The throat plate was cut (slotted) at the factory for a 0° bevel/miter cut.

The first cut you will make with the saw will be to increase this slot in the throat plate by setting the bevel scale to 45°, locking the bevel lock knob into position and cutting into the throat plate, increasing the width of the slot.

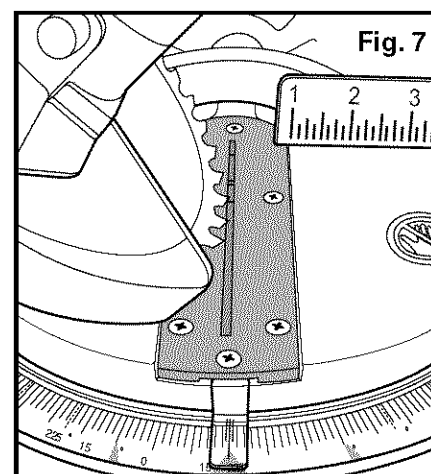

### ADJUSTING THE BLADE TO THE MITER TABLE 45° Bevel, 0° MITER (Fig. 8)

**⚠ WARNING:** Failure to unplug your saw could result in accidental starting causing serious injury.

1. Raise the saw arm.
2. Set the bevel angle scale to 45°. The miter scale should be on 0°. Lower and lock the saw arm into the "DOWN" position.
3. Place a combination square on the miter table with the rule against the table and heel of the square against the saw blade.

**NOTE:** Be sure to rest the square against the body of the blade and not against the teeth of the blade.

4. If the blade is not 45° square with the miter table, perform steps 5 through 8.
5. Loosen lock nut "B" with a 10 mm wrench (This is the outer part of the bevel angle screw "B").  
**This screw is to your right as you face the back of the saw.**
6. Loosen bevel lock knob, then adjust the blade to 45° by adjusting the set screw (inside of bevel angle screw "B") clockwise or counterclockwise with 3 mm hex key. You may have to move the saw arm by hand. It may help to hold the lock nut in place with the wrench while turning the set screw.

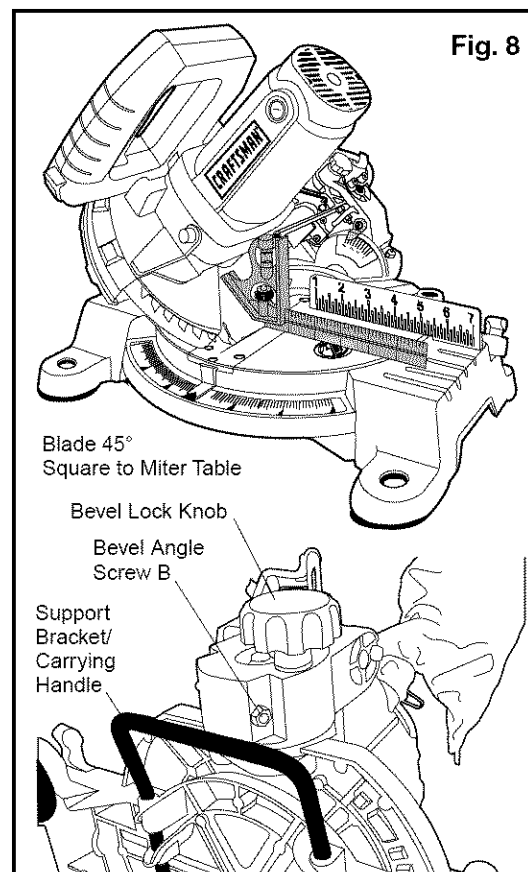

22

## ADJUSTMENTS cont.

### ADJUSTING THE BLADE TO THE MITER TABLE 45° Bevel, 0° MITER (Fig. 8) cont.

7. Once the angle is set, tighten the lock nut with the wrench while holding the set screw in place with the hex key.
8. Lock the bevel knob.

### BEVEL ANGLE INDICATOR ADJUSTMENT (Fig. 9) If Necessary

1. Check to see if the bevel angle indicator is pointing to 45° on the bevel scale.
2. If the indicator is not on 45°, loosen the bevel angle indicator screw, adjust the indicator to 45° on bevel angle scale, tighten screw.

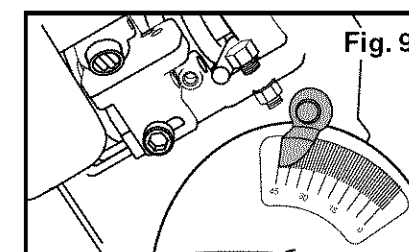

### PIVOT ADJUSTMENTS

**NOTE:** These adjustments were made at the factory and under normal circumstances do not require readjustment.

#### Saw Arm Travel Pivot Adjustment:

Your saw arm should rise (travel) completely to the up position by itself.

**⚠ WARNING:** To avoid risk of personal injury, if your saw arm does not rise by itself or if there is play in the pivot joints, have your saw serviced at a Sears Service Center before using.

#### Bevel Pivot Adjustment:

Your miter saw arm should bevel easily by loosening the bevel lock knob and tilting the saw arm to the left.

**⚠ WARNING:** To avoid risk of personal injury, if movement is tight or if there is play in the bevel pivot, have your saw serviced at a Sears Service Center before using.

### DEPTH STOP ADJUSTMENT (Fig. 10) If Necessary

The depth stop limits the downward travel of the blade. It allows the blade to go below the miter table enough to maintain full cutting capacities.

**NOTE:** The miter table support is located under the miter table and throat plate.  
The depth stop is factory set to provide maximum cutting capacity for the 7 1/4-inch blade included with your saw. Therefore the blade included with your saw should never need adjustments.  
When a new blade is installed, it is necessary to check the clearance of the blade to the miter table support (see Fig. 10a on page 24) before starting the saw. Make adjustments if necessary.

23

## ADJUSTMENTS cont.

### Depth Stop Adjustments cont. (Fig.10)

1. Unplug the saw.

**⚠ WARNING:** Failure to unplug your saw could result in accidental starting causing serious injury.

2. To adjust the depth stop use two 8mm wrenches (sold separately). Loosen the lock nut located at the rear of the miter saw arm (Fig. 10).
3. To lower the blade, adjust the hex bolt by turning it clockwise (lowering the screw). To raise the blade, adjust the hex bolt by turning it counterclockwise (raising the screw).
4. Once depth stop is adjusted, tighten lock nut.
5. Lower the blade into the throat plate of the miter table.
6. Check blade clearance and maximum cutting distance (distance from fence where blade enters throat) to front of miter table slot.
7. You may have to remove the throat plate to check the clearance between the blade and the miter table support (Fig. 10a). Replace the throat plate securely.
8. Re-adjust if necessary.

**⚠ WARNING:** DO NOT start your compound miter saw without checking for interference between the blade and the miter table support. The blade could be damaged if it strikes the miter table support during operation of the saw.

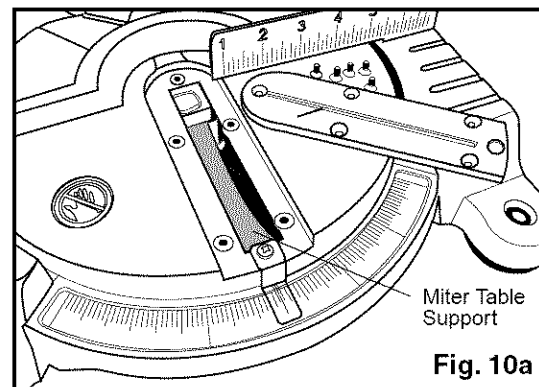

## OPERATION

**⚠ CAUTION:** ALWAYS make sure the arbor lock button is released so the blade can rotate freely. MAKE SURE that the locking pin is loose and that the saw head moves freely up and down. ENSURE that all clamps and locks are tightly in place and that there is no excessive play in any parts.

### HOW TO USE THE LASER TRAC™ FEATURE (Fig. 11)

1. Mark your workpiece with a pencil line at the point to be cut.
2. Slide the Laser Trac™ switch "On" to activate the "bright red laser line".
3. Align the "red laser line" to touch the right edge of your pencil line on the workpiece.

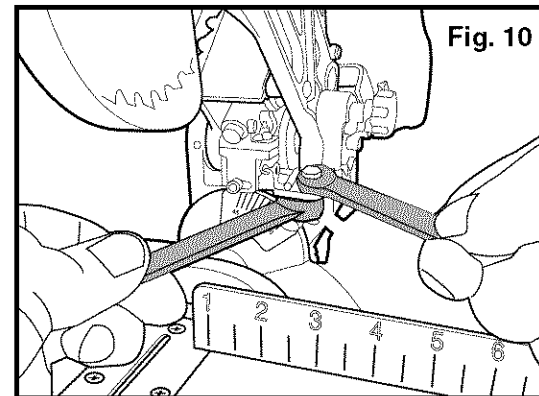

## OPERATION cont.

### HOW TO USE THE LASER TRAC™ FEATURE (Fig. 11) cont.

4. Clamp your workpiece in place with the hold down clamp.
5. Follow all of the cutting instructions for the type of cut you want to make starting on page 27.

**NOTE:** See label located on lower left of the saw base above mounting hole.

### APPLICATIONS

The blade included with this saw is ideal for a wide variety of wood cutting operations. Use your compound miter saw for the purposes listed below:

- Crosscutting wood and wood base materials.
- Crosscutting plastics, like PVC, CPVC, ABX, solid surfacing materials and other plastics.
- Crosscutting miter joints for picture frames, moldings, door casings, chair rail, shoe and baseboards.
- Compound cuts for decorative wood molding, such as chair rail, cove molding and picture frames and other fine joinery.

This tool is **NOT** recommended for cutting ferrous metals, such as iron, steel, stainless steel, or alloys of these metals. Cut **non-ferrous metals ONLY** if you are under the supervision of an experienced person. Also **DO NOT** cut stone, brick, or concrete with this miter saw.

**⚠ WARNING:** BEFORE starting any cutting operation, clamp or bolt your compound miter saw to a work bench or flat stable work surface. NEVER operate your miter saw on the floor or in a crouched position. Failure to heed this warning could result in serious personal injury.

### SUPPORTING LONG WORKPIECES (Fig.11a)

Long workpieces require extra supports. The supports should be placed along the workpiece so it does not sag. The support should allow the workpiece to lay flat on the base of the saw and work table during the cutting operation. Use the hold down clamp to secure the workpiece.

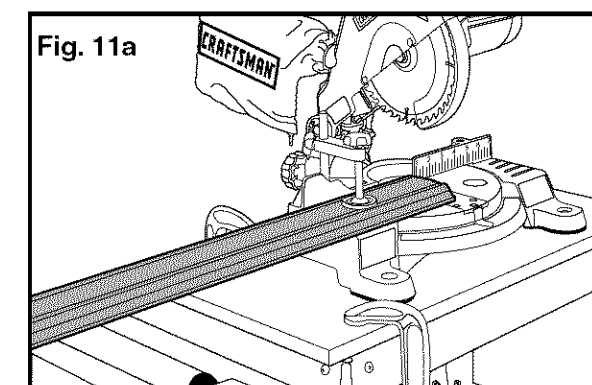

**⚠ CAUTION:** NEVER use another person as an additional support for a workpiece that is longer or wider than the basic saw table, or to help feed, support, or pull the workpiece.

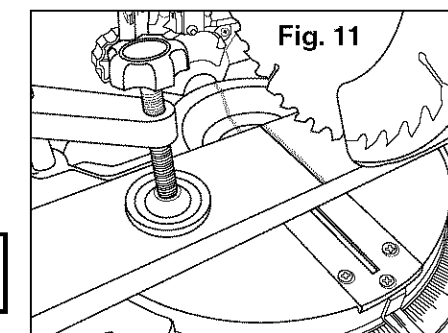

## OPERATION cont.

**⚠ WARNING:** When using the hold down clamp included or a C-clamp (sold separately) to secure the workpiece, clamp the workpiece on one side of the blade ONLY. The workpiece MUST remain unclamped on the other side of the blade to prevent the blade from binding in the workpiece. The workpiece binding the blade will cause the motor to stall and cause kickback, resulting in possible serious injury.

### USE THE FENCE AND HOLD DOWN CLAMP (Fig.12)

Align the workpiece flush against the fence to provide a straight path for the saw blade. This will help eliminate the tendency for the blade teeth to bind. Use the hold down clamp to secure the workpiece to the saw table. The hold down clamp fits into either clamp mounting hole, left or right, on the back of the fence. Clamp the workpiece to the miter table securely. The fence and the hold down clamp should both be used as a support for miter, bevel and compound cuts.

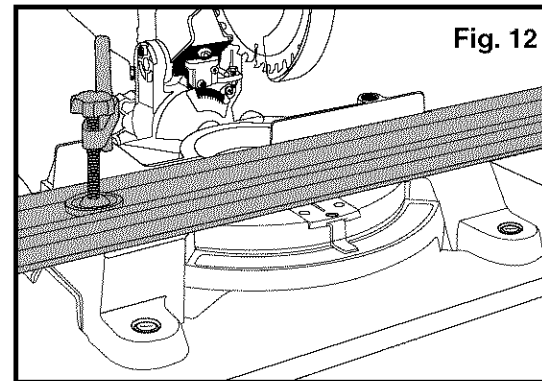

Fig. 12

### CLAMPING WIDE WORKPIECES

When cutting wide workpieces (such as 2-in. x 4-in. boards) the boards **MUST BE** clamped with the hold down clamp provided or a C-clamp (sold separately).

**⚠ CAUTION:** Pay attention to the position of your body and hands. Proper positioning of your body and hands when operating the miter saw will make cutting easier and safer. NEVER place hands near the cutting area.

### USING THE MITER SAW

**⚠ CAUTION:** Always hold the cutting handle firmly when making a cut, because the starting and stopping action of the motor may cause the handle to move up or down slightly.

**NOTE:** Make the ON/OFF trigger switch childproof. Insert a small padlock or chain with padlock through the holes in the ON/OFF trigger switch, locking the switch and preventing children or other unauthorized users from turning on the saw (Fig. 12a).

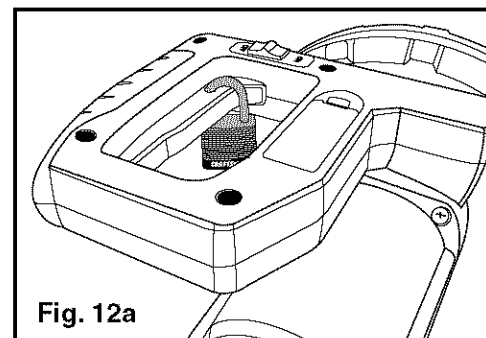

Fig. 12a

## OPERATION cont.

### CROSSCUTTING (Fig. 13 and 14)

A crosscut is a cut made across the grain of the workpiece. A straight crosscut is a cut made with the miter table set in the 0° position (Fig.13). Miter crosscuts are made with the miter table set at some angle, left or right, other than 0°.

#### To Crosscut With Your Miter Saw

1. Unplug the saw.

**⚠ WARNING:** Failure to unplug your saw could result in accidental starting causing serious injury.

2. Lock the saw arm in the down position by pushing in the locking pin.  
3. Raise miter table locking lever to loosen.

4. Hold the base of the saw arm firmly and use it to rotate the miter table while holding the saw base steady.  
5. You can quickly locate 0°, 15°, 22.5°, 30° and 45° left or right by the stops or clicks, located and/or color coded at the above angle settings.

6. Once you set the miter angle you want, tighten the miter lock lever by pushing it down.

**⚠ WARNING:** To avoid serious personal injury, ALWAYS tighten the miter lock lever securely BEFORE making a cut. Failure to do so could result in movement of the control arm or miter table while making a cut.

7. Release the saw arm by pulling out the locking pin.

8. Place the workpiece flat on the miter table with one edge securely against the fence. If the board is warped, place the convex side against the fence. If the concave edge of the board is against the fence, the board could collapse on the blade at the end of the cut and jam the blade (Figs. 19 and 20).

9. Align the "red laser line" to touch the right edge of your pencil line on the workpiece.

10. Use the hold down clamp to secure workpiece against saw table and fence.

11. When cutting long workpieces, support the opposite end of the workpiece with a roller stand or with another work surface that is level with the saw table.

**⚠ CAUTION:** NEVER use another person as an additional support for a workpiece that is longer or wider than the basic saw table, or to help feed, support, or pull the workpiece.

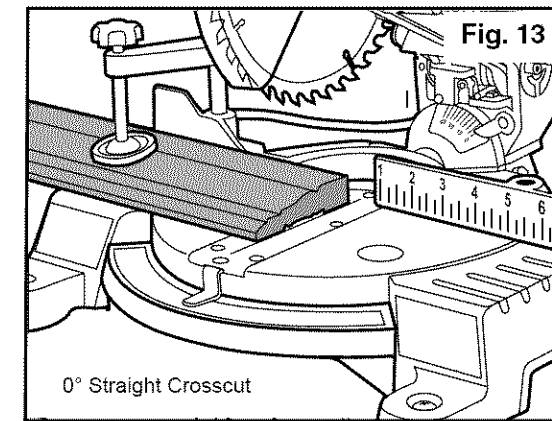

Fig. 13

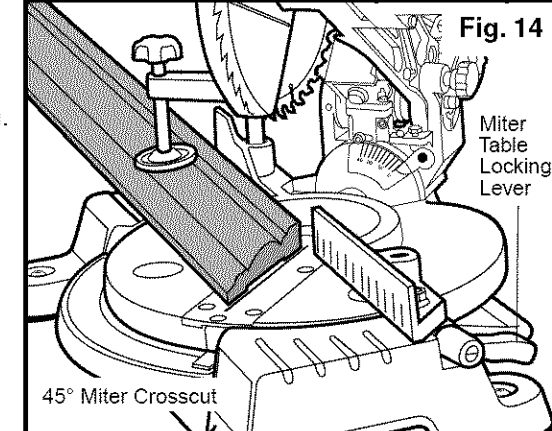

Fig. 14

45° Miter Crosscut

0° Straight Crosscut

Miter Table Locking Lever

## OPERATION cont.

### CROSSCUTTING cont. (Fig. 13 and 14)

**⚠ WARNING:** To avoid serious personal injury, ALWAYS keep your hands outside the “no hands zone”, as marked on the saw table, which is at least 3 inches from the blade. Also, NEVER perform any cutting operation “freehand” (i.e. without holding the workpiece against the fence); the blade could grab the workpiece, causing it to slip and twist.

12. BEFORE turning on the saw, perform a dry run of the cutting operation by lowering the saw arm to make sure that no problems will occur when the cut is made.
13. Hold the saw handle and use your index finger to turn on the laser switch by pushing it forward.
14. To turn on saw, push the safety lock button in with your thumb while squeezing the On/Off trigger switch located under the handle (Fig. 1a and 1b). Allow several seconds for the blade to reach maximum speed.
15. Slowly lower the blade into and through the workpiece.
16. Release the safety lock and trigger switch and turn off the laser switch. Allow the saw blade to stop rotating BEFORE raising the blade out of the workpiece.

### BEVEL CUTTING (Fig. 15)

A bevel cut is a cut made across the grain of the workpiece with the blade at an angle to the workpiece. A straight bevel cut is made with the miter table set in the 0° position and the saw arm set at a bevel angle between 0° and 45°.

#### To Bevel Cut With Your Miter Saw

1. Unplug the saw.

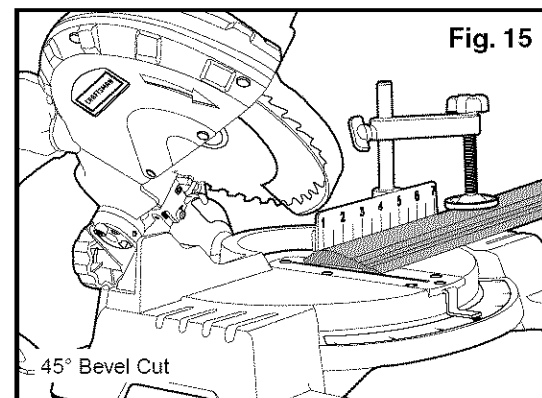

**⚠ WARNING:** Failure to unplug your saw could result in accidental starting causing serious injury.

2. Make sure the miter table is at 0° and locked, and check that the miter table lock lever is down and secured in position.

**⚠ WARNING:** To avoid serious personal injury, ALWAYS tighten the miter lock lever securely BEFORE making a cut. Failure to do so could result in movement of the control arm or miter table while making a cut.

## OPERATION cont.

### BEVEL CUTTING cont. (fig. 15)

3. Release the saw arm by pulling out the locking pin.
4. To make a bevel cut, loosen the bevel lock knob (Fig. 1b) by turning the knob counterclockwise.
5. Tilt the saw arm to the desired bevel angle as shown on the bevel scale. The blade can be positioned at any angle, from a 90° straight cut (0° on the scale) to a 45° left bevel (Fig. 15).

**⚠ WARNING:** Tighten the bevel lock knob to secure the saw arm in its position.

6. Place the workpiece flat on the miter table with one edge securely against the fence. If the board is warped, place the convex side against the fence. If the concave edge of the board is against the fence, the board could collapse on the blade at the end of the cut and jam the blade (Fig. 19 and 20).
7. Align the “red laser line” to touch the right edge of your pencil line on the workpiece.
8. Use the hold down clamp to secure workpiece against saw table and fence.
9. When cutting long workpieces, support the opposite end of the workpiece with a roller stand or with another work surface that is level with the saw table.

**⚠ CAUTION:** NEVER use another person as an additional support for a workpiece that is longer or wider than the basic saw table, or to help feed, support, or pull the workpiece.

**⚠ WARNING:** To avoid serious personal injury, ALWAYS keep your hands outside the “no hands zone”, as marked on the saw table, which is at least 3 inches from the blade. Also, NEVER perform any cutting operation “freehand” (i.e. without holding the workpiece against the fence); the blade could grab the workpiece, causing it to slip and twist.

10. BEFORE turning on the saw, perform a dry run of the cutting operation by lowering the saw arm to make sure that no problems will occur when the cut is made.
11. Hold the saw handle and use your index finger to turn on the laser switch by pushing it forward.
12. To turn on saw, push the safety lock button in with your thumb while squeezing the On/Off trigger switch located under the handle (Fig. 1a and 1b). Allow several seconds for the blade to reach maximum speed.
13. Slowly lower the blade into and through the workpiece.
14. Release the safety lock and trigger switch, and turn off the laser switch. Allow the saw blade to stop rotating BEFORE raising the blade out of the workpiece.

## OPERATION cont.

### CUTTING BASE MOLDING (Fig. 16)

Base moldings and many other moldings can be cut on a miter saw. The setup of the saw depends on base molding characteristics and applications, as shown. Perform practice cuts on scrap materials to achieve best results.

1. Always make sure moldings rest firmly against fence and table (Fig. 16). Use hold-down clamp provided, crown molding vise, or C-clamps and place tape on the area being clamped to avoid marks on the workpiece.
2. Reduce splintering by taping the cut area prior to making the cut. Mark the cut line directly on the tape.
3. Splintering typically happens due to incorrect blade style, dull blade, thinness of workpiece, or improperly dried wood.

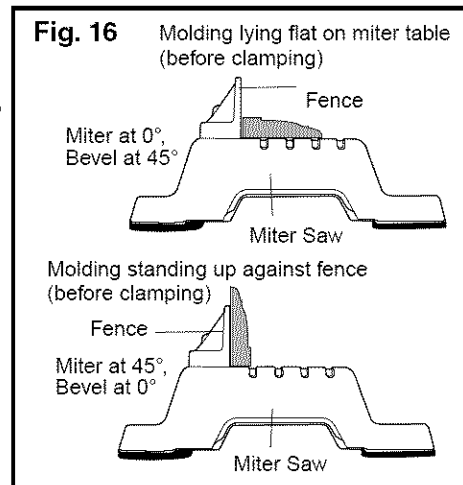

**NOTE: Always perform a dry run cut so you can determine if the operation being attempted is possible before power is applied to miter saw.**

4. Place the workpiece flat on the miter table with one edge securely against the fence. If the board is warped, place the convex side against the fence. If the concave edge of the board is against the fence, the board could collapse on the blade at the end of the cut and jam the blade (Fig. 19 and 20).
5. Align the "red laser line" to touch the right edge of your pencil line on the workpiece.
6. Use the hold down clamp to secure workpiece against saw table and fence.
7. When cutting long workpieces, support the opposite end of the workpiece with a roller stand or with another work surface that is level with the saw table.

### COMPOUND MITER CUTTING (Fig. 17)

A compound miter cut is a cut made using a miter angle and a bevel angle at the same time. This type of cut is used for decorative moldings, picture frames and other fine joinery.

To make this type of cut, the miter table must be rotated to the correct miter angle and the saw arm must be tilted to the correct bevel angle.

**ALWAYS** take special care when making compound miter cuts due to the interaction of the two angle settings.

Adjustments of miter and bevel settings are dependent on one another. Each time you adjust the miter setting, you change the effect of the bevel setting. Also, each time you adjust the bevel setting, you change the effect of the miter setting.

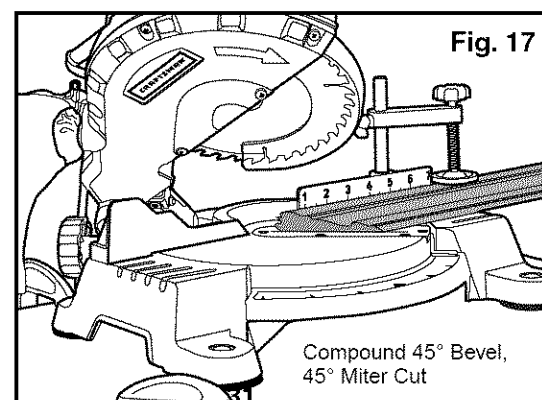

## OPERATION cont.

### COMPOUND MITER CUTTING cont. (Fig. 17)

It may take several settings to obtain the desired cut. The first angle setting should be checked after setting the second angle, since adjusting the second angle affects the first.

Once the two correct settings for a particular cut have been obtained, **ALWAYS** make a test cut in scrap material **BEFORE** making a finish cut in good material.

#### To Make a Compound Miter Cut with your Miter Saw

1. Unplug the saw.

**⚠ WARNING: Failure to unplug your saw could result in accidental starting causing serious injury.**

2. Release the saw arm by pulling out the locking pin.
3. Raise miter lock lever to loosen the miter table.
4. Hold the base of the saw arm firmly and use it to rotate the miter table while holding the saw base steady.
5. You can quickly locate 0°, 15°, 22.5°, 30° and 45° left or right by the stops or clicks, located and/or color coded at the above angle settings.
6. Once you have the miter table setting you want, tighten the miter lock lever by pushing it down.

**⚠ WARNING: To avoid serious personal injury, ALWAYS tighten the miter lock lever securely BEFORE making a cut. Failure to do so could result in movement of the control arm or miter table while making a cut.**

7. To set the bevel angle, loosen the bevel lock knob (Fig. 1b) by turning the knob counterclockwise.
8. Tilt the saw arm to the desired bevel angle as shown on the bevel scale. Bevel angles can be set from 0° to 45° left bevel.
9. Once the saw arm has been set at the desired angle, securely tighten the bevel lock knob.
10. Place the workpiece flat on the miter table with one edge securely against the fence. If the board is warped, place the convex side against the fence. If the concave edge of the board is against the fence, the board could collapse on the blade at the end of the cut and jam the blade (Figs. 19, 20 on page 34).
11. Align the "red laser line" to touch the right edge of your pencil line on the workpiece.
12. Use the hold down clamp to secure workpiece against saw table and fence.
13. When cutting long workpieces, support the opposite end of the workpiece with a roller stand or with another work surface that is level with the saw table.

**⚠ CAUTION: NEVER use another person as an additional support for a workpiece that is longer or wider than the basic saw table, or to help feed, support, or pull the workpiece.**

## OPERATION cont.

### COMPOUND MITER CUTTING cont. (Fig. 17)

**⚠ WARNING:** To avoid serious personal injury, ALWAYS keep your hands outside the “no hands zone”, as marked on the saw table, which is at least 3 inches from the blade. Also, NEVER perform any cutting operation “freehand” (i.e. without holding the workpiece against the fence); the blade could grab the workpiece, causing it to slip and twist.

14. Make sure that there will be no obstructions to interfere with when making the cut.
15. Hold the saw handle and use your index finger to turn on the laser switch by pushing it forward.
16. To turn on saw, push the safety lock button in with your thumb while squeezing the On/Off trigger switch located under the handle (Fig.1a and 1b). Allow several seconds for the blade to reach maximum speed.
17. Slowly lower the blade into and through the workpiece.
18. Release the safety lock and trigger switch, and turn off the laser switch. Allow the saw blade to stop rotating **BEFORE** raising the blade out of the workpiece.

### CUTTING COMPOUND MITERS

To help you to make the correct settings, use the compound angle setting chart below. Since compound cuts are the most difficult to accurately obtain, plan carefully and make trial cuts in scrap material prior to making your required cut.

*PITCH OF SIDE	NUMBER OF SIDES						
	3	4	5	6	7	8	9
0°	M-45.00° B- 0.00°	M-36.00° B- 0.00°	M-30.00° B- 0.00°	M-25.71° B- 0.00°	M-22.50° B- 0.00°	M-20.00° B- 0.00°	M-18.00° B- 0.00°
5°	M-44.89° B- 3.53°	M-35.90° B- 2.94°	M-29.91° B- 2.50°	M-25.63° B- 2.17°	M-22.42° B- 1.91°	M-19.93° B- 1.71°	M-17.94° B- 1.54°
10°	M-44.56° B- 7.05°	M-35.58° B- 5.86°	M-29.62° B- 4.98°	M-25.37° B- 4.32°	M-22.19° B- 3.81°	M-19.72° B- 3.40°	M-17.74° B- 3.08°
15°	M-44.01° B- 10.55°	M-35.06° B- 8.75°	M-29.15° B- 7.44°	M-24.95° B- 6.45°	M-21.81° B- 5.68°	M-19.37° B- 5.08°	M-17.42° B- 4.59°
20°	M-43.22° B- 14.00°	M-34.32° B- 11.60°	M-28.48° B- 9.85°	M-24.35° B- 8.53°	M-21.27° B- 7.52°	M-18.88° B- 6.72°	M-16.98° B- 6.07°
25°	M-42.19° B- 17.39°	M-33.36° B- 14.38°	M-27.62° B- 12.20°	M-23.35° B- 10.57°	M-20.58° B- 9.31°	M-18.26° B- 6.72°	M-16.41° B- 7.50°
30°	M-40.89° B- 20.70°	M-32.18° B- 17.09°	M-26.57° B- 14.48°	M-22.64° B- 12.53°	M-19.73° B- 11.03°	M-17.50° B- 9.85°	M-15.72° B- 8.89°
35°	M-39.32° B- 23.93°	M-30.76° B- 19.70°	M-25.31° B- 16.67°	M-21.53° B- 14.41°	M-18.74° B- 12.68°	M-16.60° B- 11.31°	M-14.90° B- 10.21°
40°	M-37.45° B- 27.03°	M-29.10° B- 22.20°	M-23.86° B- 18.75°	M-20.25° B- 16.19°	M-17.60° B- 14.24°	M-15.58° B- 12.70°	M-13.98° B- 11.46°
45°	M-35.26° B- 30.00°	M-27.19° B- 24.56°	M-22.21° B- 20.70°	M-18.80° B- 17.87°	M-16.32° B- 15.70°	M-14.43° B- 14.00°	M-12.94° B- 12.62°
50°	M-32.73° B- 32.80°	M-25.03° B- 26.76°	M-20.36° B- 22.52°	M-17.20° B- 19.41°	M-14.91° B- 17.05°	M-13.17° B- 15.19°	M-11.80° B- 13.69°

## OPERATION cont.

### CUTTING COMPOUND MITERS cont.

*PITCH OF SIDE	NUMBER OF SIDES						
	3	4	5	6	7	8	9
55°	M-29.84° B- 35.40°	M-22.62° B- 28.78°	M-18.32° B- 24.18°	M-15.44° B- 20.82°	M-13.36° B- 18.27°	M-11.79° B- 16.27°	M-10.56° B- 14.66°
60°	M-26.57° B- 37.76°	M-19.96° B- 30.60°	M-16.10° B- 25.66°	M-13.54° B- 22.07°	M-11.70° B- 19.35°	M-10.31° B- 17.23°	M- 9.23° B- 15.52°
65°	M-22.91° B- 39.86°	M-17.07° B- 32.19°	M-13.71° B- 26.95°	M-11.50° B- 23.16°	M- 9.93° B- 20.29°	M- 8.74° B- 18.06°	M- 7.82° B- 16.26°
70°	M-18.88° B- 41.64°	M-13.95° B- 33.53°	M-11.17° B- 28.02°	M- 9.35° B- 24.06°	M- 8.06° B- 21.08°	M- 7.10° B- 18.75°	M- 6.34° B- 16.88°
75°	M-14.51° B- 43.08°	M-10.65° B- 34.59°	M- 8.50° B- 28.88°	M- 7.10° B- 24.78°	M- 6.12° B- 21.69°	M- 5.38° B- 19.29°	M- 4.81° B- 17.37°
80°	M- 9.85° B- 44.14°	M- 7.19° B- 35.37°	M- 5.73° B- 29.50°	M- 4.78° B- 25.30°	M- 4.11° B- 22.14°	M- 3.62° B- 19.68°	M- 3.23° B- 17.72°
85°	M- 4.98° B- 44.78°	M- 3.62° B- 35.84°	M- 2.88° B- 29.87°	M- 2.40° B- 25.61°	M- 2.07° B- 22.41°	M- 1.82° B- 19.92°	M- 1.62° B- 17.93°
90°	M- 0.00° B- 45.00°	M- 0.00° B- 36.00°	M- 0.00° B- 30.00°	M- 0.00° B- 25.71°	M- 0.00° B- 22.50°	M- 0.00° B- 20.00°	M- 0.00° B- 18.00°

Each B (Bevel) and M (Miter) Setting is listed to the closest 0.005°

### COMPOUND-ANGLE SETTINGS FOR POPULAR STRUCTURES

\*Pitch of Side = Angle of side from vertical. Example: 

### CUTTING CROWN MOLDING (Fig. 18)

Your miter saw is ideal for cutting crown molding. In order to fit properly, crown molding must be compound-mitered with extreme accuracy. To fit flat against the ceiling and wall, the sum of the angles of the crown molding's two connecting surfaces must equal 90° (Fig. 18).

Most crown molding has a high top rear spring angle (the section that fits flat against the ceiling) of 52° and a bottom rear spring angle (the section that fits flat against the wall) of 38°.

In order to accurately cut crown molding for a 90° inside or outside corner, lay the molding with its broad back surface flat on the miter table and against the fence (Fig. 18).

When setting the bevel and miter angles for compound miter cuts, remember that the settings are interdependent; changing one changes the other, as well.

Keep in mind that since it is very easy for the angles of crown molding to shift slightly, all settings should be tested on scrap molding. Also, most walls do not have angles of precisely 90°, therefore, you will need to fine tune your settings.

When cutting crown molding using this method, the bevel angle should be set at 33.9°. The miter angle should be set at 31.6° either left or right, depending upon the desired cut for the application. See the following table for correct angle setting and correct positioning of the crown molding on the miter table.

## OPERATION cont.

### CUTTING CROWN MOLDING cont. (Fig. 18)

The settings in the table below can be used for cutting all standard (U.S.) crown molding with 52° and 38° spring angles. The crown molding is placed flat on the miter table, using the compound features of your miter saw.

Always use the hold down clamp, and place tape on the area being clamped to avoid marks on the workpiece.

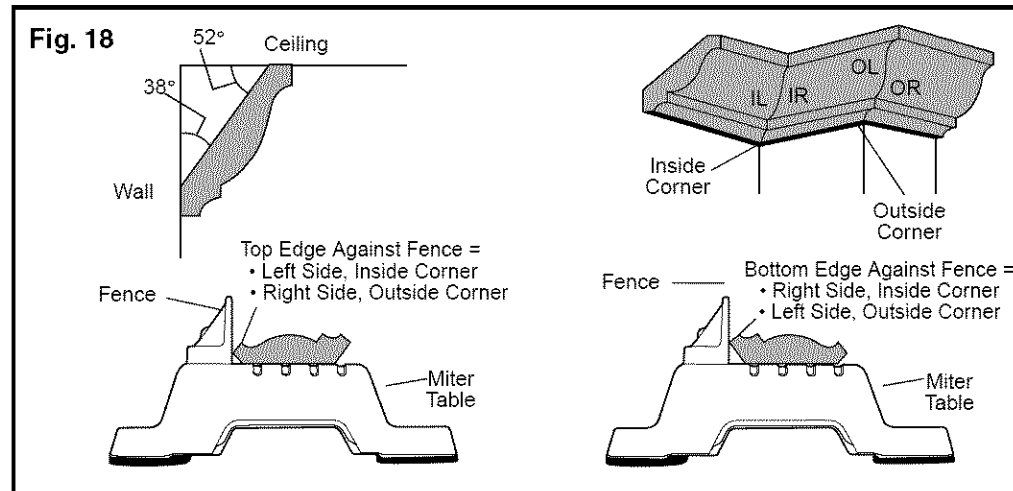

### COMPOUND BEVEL/MITER SETTINGS

Key	Bevel Setting	Miter Setting	Type of cut
IL	33.9°	31.6° Right	<b>Inside corner - Left side</b> 1. Position top of molding against fence. 2. Miter table set at RIGHT 31.6° 3. LEFT side is finished piece.
IR	33.9°	31.6° Left	<b>Inside corner - Right side</b> 1. Position top of molding against fence. 2. Miter table set at LEFT 31.6° 3. LEFT side is finished piece.
OL	33.9°	31.6° Left	<b>Outside corner - Left side</b> 1. Position top of molding against fence. 2. Miter table set at LEFT 31.6° 3. RIGHT side is finished piece.
OR	33.9°	31.6° Right	<b>Outside corner - Right side</b> 1. Position top of molding against fence. 2. Miter table set at RIGHT 31.6° 3. RIGHT side is finished piece.

## OPERATION cont.

### CUTTING WARPED MATERIAL (Fig. 19 and 20)

**⚠ WARNING: To avoid kickback and to avoid serious personal injury NEVER position the concave side of bowed or warped material against the fence.**

When cutting **warped** material, **BE CERTAIN** that the material to be cut is positioned on the miter table with the **convex** side **against** the fence, as shown (Fig. 19)

If the warped material is positioned the wrong way, (Fig. 20), it will pinch the blade near the end of the cut.

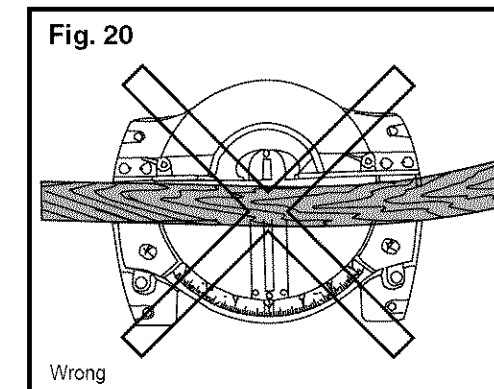
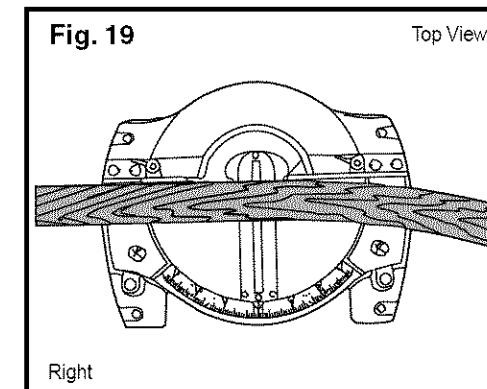

## MAINTENANCE

**⚠ WARNING: To ensure safety and reliability, all repairs - with the exception of the externally accessible brushes - should be performed by a qualified service technician at a Sears Service Center**

**⚠ WARNING: For your safety, ALWAYS turn off switch and unplug miter saw from the power source before performing any maintenance or cleaning**

Electric tools are subject to accelerated wear and possible premature failure when they are used to work on fiber glass boats and sports cars, wallboard, spackling compounds or plaster. The chips and grindings from these materials are highly abrasive to electrical tool parts, such as bearings, brushes, commutators, etc. Consequently, it is not recommended that this tool be used for extended work on any fiberglass material, wallboard, spackling compound or plaster. During any use on these materials, **it is extremely important** that the tool is cleaned frequently by blowing with an air jet.

**⚠ WARNING: Always wear safety goggles or safety glasses with side shields during power tool operations, or when blowing dust. If operation is dusty, also wear a dust mask.**

## MAINTENANCE cont.

### ROUTINE MAINTENANCE

**⚠ WARNING: DO NOT at any time let brake fluids, gasoline, petroleum-based products, penetrating oils, etc. come in contact with plastic parts. Chemicals can damage, weaken or destroy plastic, which may result in serious personal injury.**

Periodic maintenance allows for long life and trouble-free operation. A cleaning, lubrication and maintenance schedule should be maintained. As a common preventive maintenance practice, follow these recommended steps:

1. When work has been completed, clean the tool to allow smooth functioning of the tool over time.
2. Use clean damp cloths to wipe the tool.
3. Check the state of all electrical cables.
4. Keep the motor air openings free from oil, grease and sawdust or woodchips and store tool in a dry place.
5. Be certain that all moving parts are well lubricated, particularly after lengthy exposure to damp and/or dirty conditions.

### CHANGING THE BLADE (Fig. 21)

**⚠ WARNING: To prevent personal injury, ALWAYS disconnect the plug from power source BEFORE assembling parts, making adjustments or changing blades.**

**⚠ WARNING: BE SURE to wear protective work gloves while handling a saw blade. The blade can injure unprotected hands.**

1. Raise the saw arm.
2. Use Phillips screwdriver, loosen but do not remove screw on the arbor screw guard by turning counterclockwise.
3. Rotate arbor guard to expose the arbor.
4. Press and hold arbor lock button while loosening and removing the left-hand-thread arbor screw by turning clockwise with the wrench included.
5. Lift and hold up the lower blade guard.
6. Remove the outer blade flange.
7. Remove blade from arbor.  
Wipe the flanges and arbor to remove dust and debris.

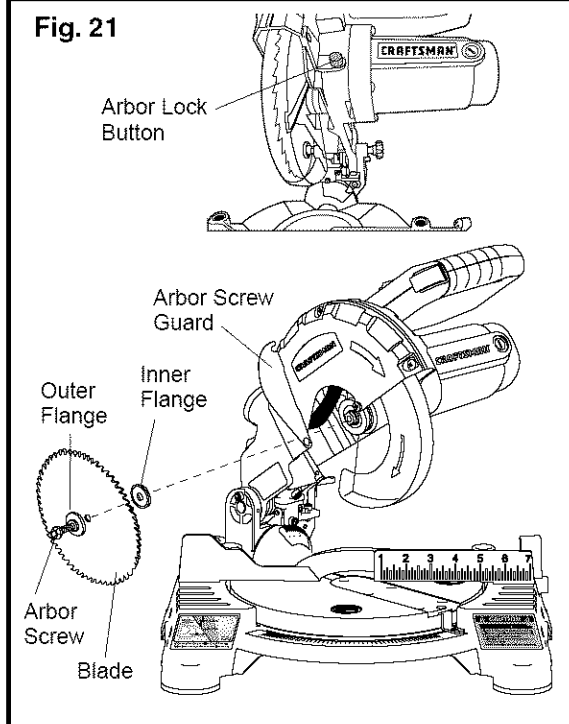

36

## MAINTENANCE cont.

### CHANGING THE BLADE cont. (see Fig. 21)

8. Take the new blade and match the direction of the arrow on it with the direction of the arrow on the upper blade guard. Make sure the blade teeth are pointing downward. Install the blade by sliding the blade into the upper blade guard and placing the blade up and onto the arbor.  
**Note:** inner flange will already be on the arbor.
9. Replace the outer blade flange, making sure the flat side of the flange is against the blade. Replace the arbor screw and tighten counterclockwise with the supplied wrench while holding in the arbor lock button until lock engages, then tightening the arbor screw securely.
10. Rotate the arbor guard into position and securely tighten its screw by turning clockwise with the Phillips screwdriver.
11. Lower the saw arm and check the clearance between the blade and the miter table. The blade should rotate freely. See Depth Stop Adjustment on (Fig. 10 on page 24)

**⚠ CAUTION: ALWAYS make sure the spindle lock button is released so the blade can rotate freely. MAKE SURE that the locking pin is loose and that the saw head moves freely up and down. ENSURE that all clamps and locks are tightly in place and that there is no excessive play in any parts.**

### CHANGING THE LASER BATTERIES (Fig. 22)

**⚠ WARNING: Unplug your miter saw before performing any maintenance. Failure to unplug the saw could result in accidental starting causing possible serious personal injury.**

1. Open the laser battery compartment (Fig. 22)
2. Remove the two worn batteries. Before replacing the batteries, thoroughly clean the battery compartment. Use a soft dry paintbrush or similar device to remove all sawdust and debris.
3. Insert new batteries, ensuring that the polarity is correct (see the mark stamped on battery compartment). Replace the battery cover.

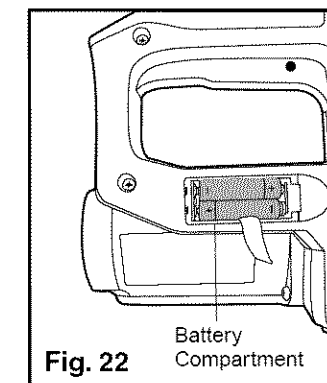

**NOTE: Replace with two AAA batteries that have a rating of 1.5 volts.**

### REPLACEMENT OF CARBON BRUSHES (Fig. 23, 24)

The factory installed carbon brushes in the motor assembly will last for approximately 50 hours of running time, or 10,000 ON/OFF cycles. Replacement brush sets are available through Sears Parts and Repair Centers.

1. First unplug the saw before inspecting or replacing brushes.
2. Replace both carbon brushes when either has less than 1/4-in. length of carbon remaining, or if the spring or wire is damaged or burned.

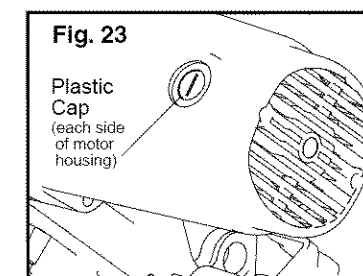

37

## MAINTENANCE cont.

### REPLACEMENT OF CARBON BRUSHES cont.

- Using a slotted screwdriver, remove the black plastic cap on each side of the motor housing (Fig. 23), and carefully withdraw the spring-loaded brush assemblies. Keep brushes clean and sliding freely in their guide channels.

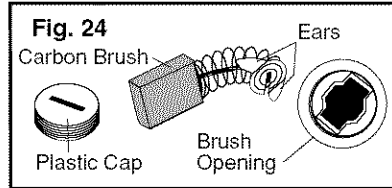

**NOTE:** To reinstall the same brushes, make sure the brushes go back in the same way they came out. This will avoid a break-in period.

- Insert new brush assemblies into guide channels, **with the carbon part going in first**, being certain to fit the two metal "ears" into their slots in the channel (Fig. 24).
- Remember to replace both end caps after inspecting or servicing brushes. Tighten the caps snugly, **but do not over-tighten**. The saw should be allowed to "RUN IN" (run at no-load without a blade) for 5 minutes before use, to seat the new brushes properly.

**⚠ WARNING:** WHILE "RUNNING IN", DO NOT TIE, TAPE, OR OTHERWISE LOCK THE TRIGGER SWITCH "ON"! HOLD THE TRIGGER SWITCH "ON" BY HAND ONLY!

### LOWER BLADE GUARD

**⚠ WARNING:** DO NOT use the saw without the lower blade guard. The lower blade guard is attached to the saw for your protection. Should the lower blade guard become damaged, do not use the saw until the damaged guard has been replaced. Check the lower blade guard regularly, making certain that it is in proper working order.

**⚠ CAUTION:** When cleaning the lower blade guard, unplug the saw from the power source receptacle to avoid unexpected startup.

**NOTE:** Do not use solvents on the guard, as they may cause any plastic parts to become "cloudy" or brittle.

### SAWDUST

Periodically, sawdust will accumulate under the worktable and base. This could cause difficulty in the movement of the worktable when setting up a miter cut. Frequently blow out or vacuum up the sawdust.

**⚠ WARNING:** Always wear safety goggles or safety glasses with side shields during power tool operations, or when blowing dust. If operation is dusty, also wear a dust mask.

### LUBRICATION

All the motor bearings in this tool are lubricated with a sufficient amount of high-grade lubricant for the life of the unit, under normal operating conditions; therefore, no further lubrication is required.

## TROUBLESHOOTING

PROBLEM	PROBLEM CAUSE	SUGGESTED CORRECTIVE ACTION
Brake does not stop blade within 6 seconds.	Motor brushes not sealed or lightly sticking,	Inspect /clean /replace brushes. "See MAINTENANCE section."
	Motor brake overheated from use of defective or wrong size blade or rapid ON/OFF cycling.	Use a recommended blade.
	Arbor bolt loose.	Retighten.
Motor does not start.	Fuse.	Check time delay fuse or circuit breaker.
	Brush worn.	Replace brushes. "See MAINTENANCE section."
Brush sparks excessively when switch released.	Brush worn / damaged.	Replace brushes. "See MAINTENANCE section."
Blade hits table	Misalignment.	"See ADJUSTMENT section."
Angle of cut inaccurate	Miter table unlocked.	Use miter table locking lever "See ADJUSTMENT section."
	Too much sawdust under table.	Vacuum or blow out dust. WEAR EYE PROTECTION!
Cutting arm cannot fully raise or blade guard cannot fully close.	Parts failure.	Contact Sears Service Center.
	Pivot spring not replaced properly after service.	Contact Sears Service Center.
	Sawdust buildup.	Clean and lubricate moving parts.
Blade binds, jams, burns wood	Improper operation.	"See OPERATION section."
	Dull blade.	Replace or sharpen blade.
	Improper blade.	Replace blade.
	Warped blade.	Replace blade.
Saw vibrates or shakes	Saw blade damaged.	Replace blade.
	Saw blade loosened.	Tighten arbor bolt.

**Contact Sears Service Center when the problems remain unsolved after the above checks.**

**REPAIR PARTS**

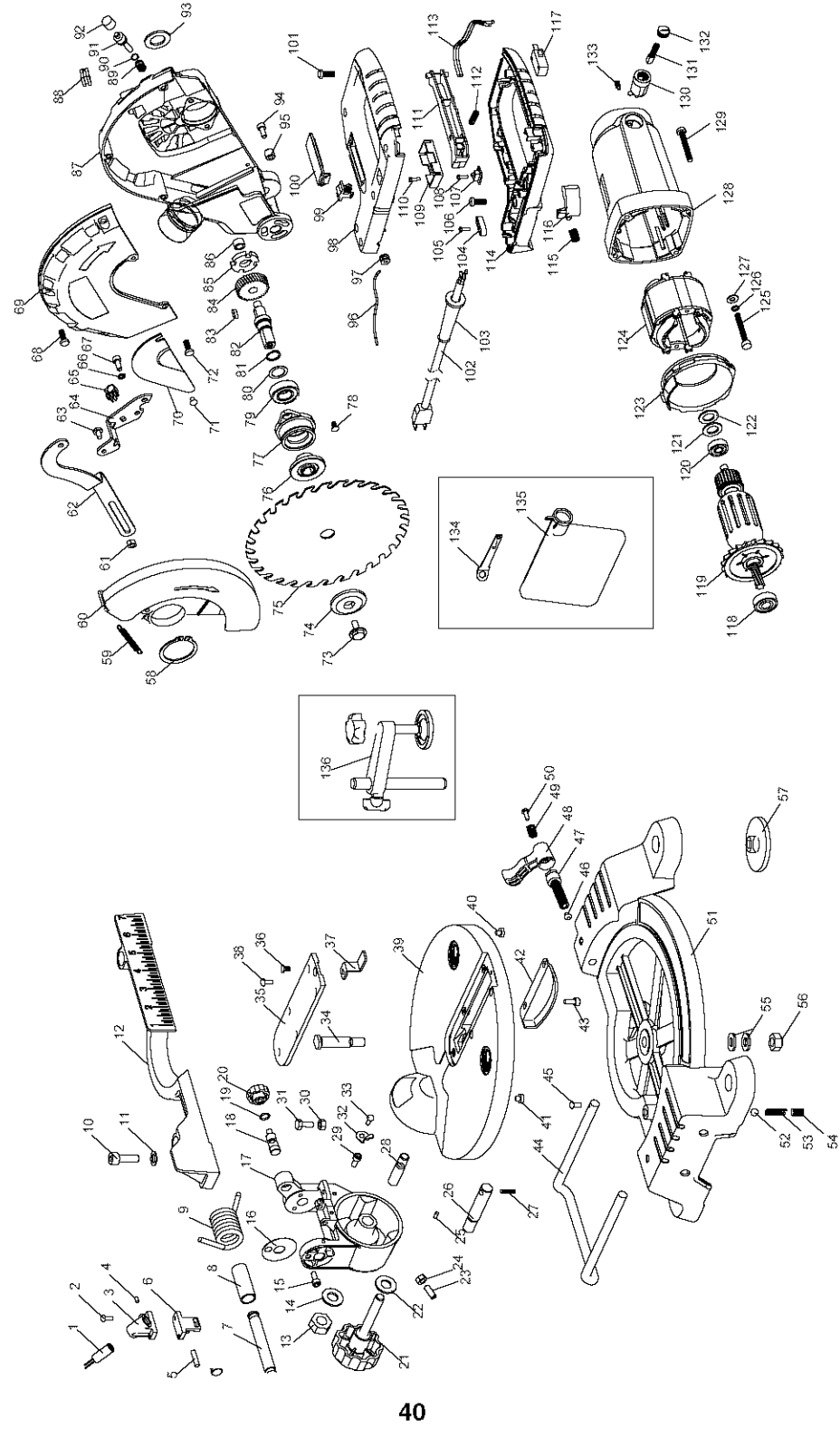

**REPAIR PARTS cont.**

**7 1/4-in. FINISHING SAW – MODEL NUMBER 320.21180**

The Model Number will be found on the Nameplate. Always mention the Model Number in all correspondence regarding your tool.

Item No.	Parts No.	Part Description	Qty.	Item No.	Parts No.	Part Description	Qty.
1	DS.JG1M.0	Laser	1	36	T0234008211	Screw	5
2	T0203010212	Screw	2	37	3121274000	Indicator	1
3	3121277000	Laser Holder	1	38	T0214008212	Screw	1
4	T0264006311	Screw	2	39	3420305000	Turntable	1
5	5670028000	Pin	1	40	3121140000	POM Insert	4
6	3420304000	Laser Support	1	41	3121139000	POM Insert	2
7	3550335000	Shaft	1	42	3121275000	Bottom Guard	1
8	3550476000	Shaft Sleeve	1	43	T0214008212	Screw	2
9	3660140000	Spring	1	44	3550502000	Balance Support	1
10	T0208025212	Screw	2	45	T0214008212	Screw	1
11	T040803021	Plain Washer	2	46	3121271000	POM Insert	1
12	3420306000	Fixed Fence	1	47	3550472000	Miter Lock Bolt	1
13	T031215052	Prevaling Torque Type Hex Nut w/ Non-Metallic Insert	1	48	3121272000	Lever	1
14	T041203031	Plain Washer	1	49	3660133000	Spring	1
15	5620199000	Screw	1	50	5620206000	Screw	1
16	5650045000	Washer	2	51	3420302000	Bottom Support	1
17	3420303000	Bevel Support	1	52	T070000081	Ball	1
18	3550337000	Locking Pin	1	53	3660142000	Spring	1
19	T052061822	"O" Ring	1	54	T0201010312	Screw	1
20	3121276000	Locking Pin Knob	1	55	T041003031	Plain Washer	2
21	3400043000	Bevel Lock Knob	1	56	T031015052	Prevaling Torque Type Hex Nut with Non-Metallic Insert	1
22	T041003031	Plain Washer	1	57	3121138000	Foot	4
23	T0206014212	Screw	2	58	T043813031	Circclips for Shaft-Type A	1
24	T030601021	Hexagonal Nut Style 1	2	59	3660139000	Spring	1
25	T0264008382	Screw	1	60	3400150000	Lower Guard	1
26	3550336000	Shaft	1	61	T030515021	Prevaling Torque Type Hex Nut with Non-Metallic Insert	1
27	T0265016382	Screw	1	62	3700637000	Link	1
28	3550377000	Bolt	1	63	5620207000	Screw	2
29	DS.CS7.0.2-6	Screw	1	64	3700636000	Link Support	1
30	T030501022	Hexagonal Nut Style 1	1	65	3121338000	Wire Holder	1
31	T1610501621	Screw	1	66	T040509031	Single Coil Spring Lock Washer Normal Type	2
32	3700638000	Indicator	1	67	T0205012331	Screw	2
33	T0214008212	Screw	1	68	T0115016551	Screw	3
34	3550338000	Shaft	1				
35	3121273000	Table Insert	1				

SEE BACK PAGE FOR PARTS ORDERING INSTRUCTIONS



Get it fixed, at your home or ours!

### Your Home

For repair—in your home—of **all** major brand appliances, lawn and garden equipment, or heating and cooling system, **no matter who made it, no matter who sold it!**

For the replacement parts, accessories and owner's manuals that you need to do-it-yourself.

For Sears professional installation of home appliances and items like garage door openers and water heaters.

**1-800-4-MY-HOME®** (1-800-469-4663)

Call anytime, day or night (U.S.A. and Canada)

[www.sears.com](http://www.sears.com) [www.sears.ca](http://www.sears.ca)

### Our Home

For repair of carry-in items like vacuums, lawn equipment, and electronic, call or go on-line for the location of your nearest **Sears Parts & Repair Center.**

**1-800-488-1222**

Call anytime, day or night (U.S.A. only)

[www.sears.com](http://www.sears.com)

To purchase a protection agreement (U.S.A.) or maintenance agreement (Canada) on a product serviced by Sears:

**1-800-827-6655** (U.S.A.) **1-800-361-6665** (Canada)

Para pedir servicio de reparación a domicilio, y para ordenar piezas:

**1-888-SU-HOGAR®**  
(1-888-784-6427)

Au Canada pour service en français:

**1-800-LE-FOYER<sup>MC</sup>**  
(1-800-533-6937)  
[www.sears.ca](http://www.sears.ca)

©Sears Brands, LLC

® Registered Trademark / ™ Trademark / ℠ Service Mark of Sears Brands, LLC

© Marca Registrada / ™ Marca de F-brica / ℠ Marca de Servicio de Sears Brands, LLC

<sup>MC</sup> Marque de commerce / <sup>MD</sup> Marque déposée de Sears Brands, LLC