

# 3 POINT SNOW BLOWER

Model: TSB48 TSB48T TSB72 TSB72T  
TSB60 TSB60T TSB84 TSB84T

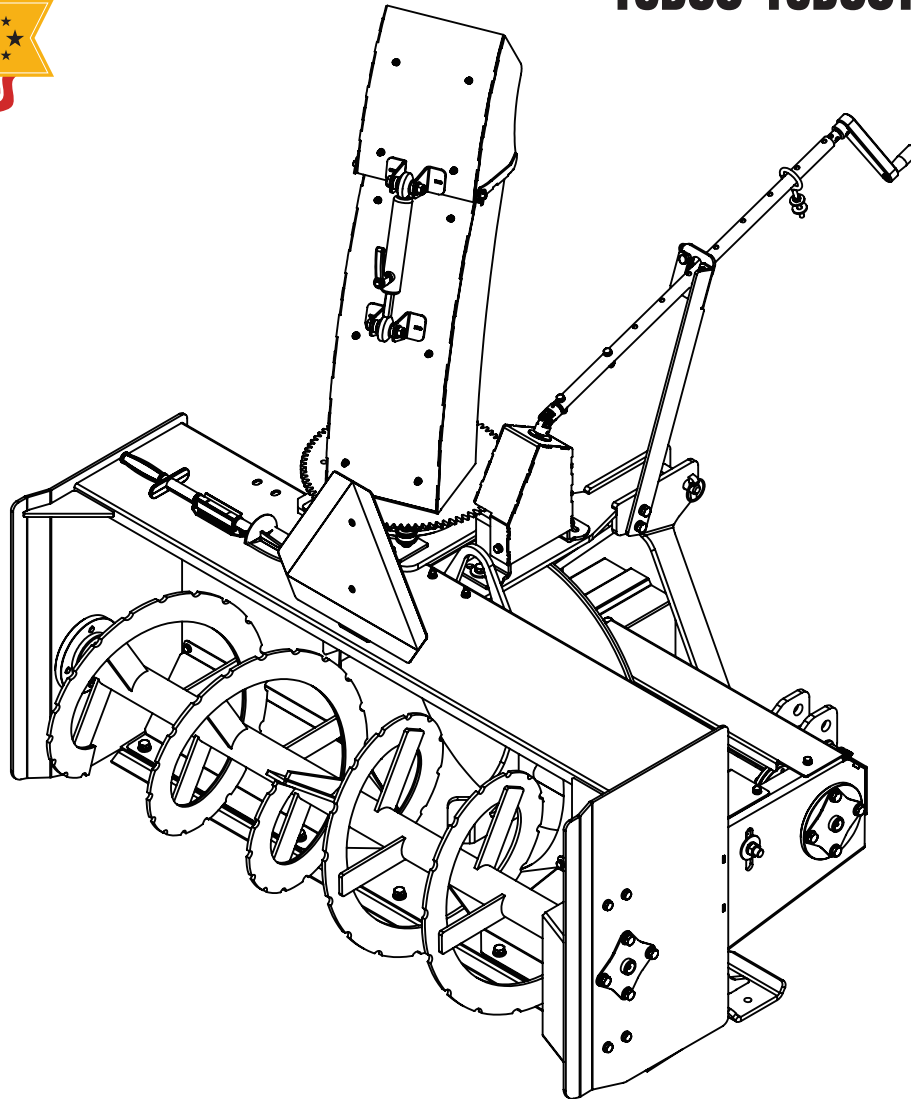

## Operator's Manual

**MechMaxx**

[www.mechmaxx.com](http://www.mechmaxx.com)





---

## TABLE OF CONTENTS

---

<b>TABLE OF CONTENTS</b> .....	1
<b>GENERAL SAFETY INSTRUCTIONS</b> .....	3
OPERATION SAFETY .....	3
TRANSPORT SAFETY .....	3
SERVICE AND MAINTENANCE SAFETY .....	3
STORAGE SAFETY .....	4
SAFETY SIGNS .....	4
<b>SAFETY DECAL</b> .....	5
<b>SPECIFICATIONS</b> .....	6
<b>MAINTENANCE AND STORAGE</b> .....	7
STORAGE .....	7
<b>BOLT TORQUE</b> .....	8
<b>TROUBLESHOOTING</b> .....	9
<b>PARTS DIAGRAM</b> .....	10
<b>PARTS LIST</b> .....	11

## WARNING



- Please read the product manual completely before assembly
- Check against the parts list to make sure all parts are received
- Wear proper safety goggles or other protective gears while in assembly

## SAFETY INSTRUCTIONS

Remember, YOU are the key to safety. Good safety practices not only protect you, but also the people around you. Make these practices a working part of your safety program. Be certain that everyone operating this equipment is familiar with the recommended operating and maintenance procedures and follows all the safety precautions. Most accidents can be prevented. Do not risk injury or death by ignoring good safety practices.

The alert symbol is used throughout this manual. It indicates attention is required and identifies hazards. Follow the recommended precautions.



The safety alert symbol means...

**ATTENTION! BECOME ALERT! YOUR SAFETY IS INVOLVED!**



The caution symbol indicates a potentially hazardous situation that, if not avoided, may result in minor or moderate injury. It may also be used to alert against unsafe practices.



The Warning Symbol indicates a potentially hazardous situation that, if not avoided, could result in death or serious injury, and includes hazards that are exposed when guards are removed. It may also be used to alert against unsafe practices.



The Danger Symbol indicates an imminently hazardous situation that, if not avoided will result in death or serious injury. This signal word is to be limited to the most extreme situations, typically for machine components that, for functional purposes, cannot be guarded.

## GENERAL SAFETY INSTRUCTIONS

- Have a first-aid kit available for use and know how to use it.
- Have a fire extinguisher available, stored in a highly visible location, and know how to use it.
- Wear appropriate protective gear. This list may include but is not limited to:
  - hard hat
  - protective shoes with slip resistant soles
  - protective glasses or goggles
  - heavy gloves
  - wet weather gear
  - hearing protection
  - respirator or filter mask
- Read and understand the Operator's Manual and all safety signs before operating, servicing, adjusting, repairing, or unplugging the equipment.
- Do not attempt any unauthorized modifications to your product as this could affect function or safety, and could affect the life of the equipment.
- Never start or operate the snow blower except from the operator's station on the power unit.
- Inspect and clean the working area before operating.
- Keep hands, feet, clothing, and hair away from moving parts.
- Ensure bystanders are clear of the area before operating.
- Do not let inexperienced operators or children run this equipment.
- Place all tractor and machine controls in neutral before starting.
- Operate only with ROPS and seatbelt equipped tractors.
- Do not operate inside a building unless there is adequate ventilation.
- Ensure all shields are in place and in good condition before operating.
- Stay clear of PTO shaft and machine when engaging PTO.

### OPERATION SAFETY

- Do not permit riders.
- Do not wear loose fitting clothing during operation.
- Do not allow anyone other than the operator close to the Auger when in operation.
- Stay clear of snow blower augers.
- Stay clear of snow blower discharge chute. Rocks or debris can be picked up and thrown.
- Never operate over 540 PTO rpm speed.
- Never operate equipment in the raised position.

### TRANSPORT SAFETY

- Review Transport Safety instructions in tractor manual before moving.
- Check with local authorities regarding transport on public roads. Obey all applicable laws and regulations.
- Make sure the SMV (Slow Moving Vehicle) emblem and all the lights and reflectors that are required by the local highway and transport authorities are in place, are clean, and can be seen clearly by all overtaking and oncoming traffic.
- Never have the equipment in operation during transport.
- Always travel at a safe speed.

### SERVICE AND MAINTENANCE SAFETY

- Stop engine, set brake, remove ignition key, and wait for all moving parts to stop before servicing, adjusting, repairing, or unplugging.
- Support the equipment with blocks or safety stands before working beneath it.
- Follow good shop practices including:
  - keep service area clean and dry
  - be sure electrical outlets and tools are properly grounded
  - use adequate light for the job.
- Use only tools, jacks, and hoists of sufficient capacity for the job.
- Replace and secure all shields removed during servicing before operating.
- Use heavy leather gloves to handle sharp objects.
- Check hydraulics regularly for leaks. Use cardboard to look for leaks, and use hand and eye protection.

- Relieve pressure on hydraulic system before repairing or adjusting.

### **STORAGE SAFETY**

- Store the unit in an area away from human activity.
- Do not permit children to play on or around the stored machine.
- Support the frame on stands and blocks to provide a secure base.

### **SAFETY SIGNS**

- The following illustration shows the approximate location and detail of safety signs.
- Keep all safety signs clean and legible and replace any that are damaged or missing.
- When original parts are replaced, any safety signs affixed to those parts should be replaced as well.
- Replacement safety signs are available from your local dealer.

## SAFETY DECAL

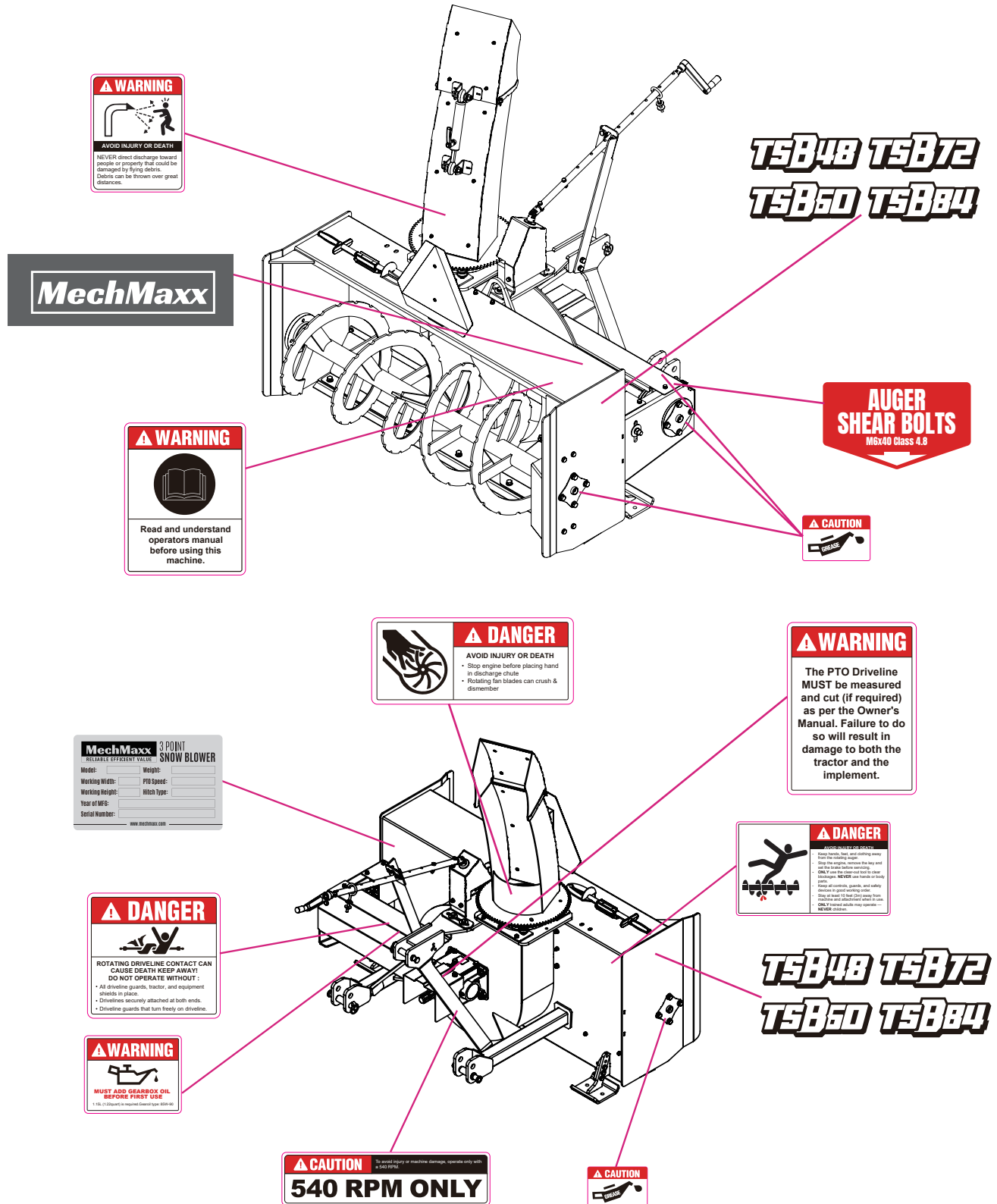

**WARNING**

**AVOID INJURY OR DEATH**

NEVER direct discharge toward people or property that could be damaged by flying debris. Debris can be thrown over great distances.

**MechMaxx**

**TSB48 TSB72**  
**TSB50 TSB84**

**WARNING**

**Read and understand operators manual before using this machine.**

**AUGER SHEAR BOLTS**  
M6x40 Class 4.8

**CAUTION**

**GREASE**

**DANGER**

**AVOID INJURY OR DEATH**

- Stop engine before placing hand in discharge chute
- Rotating fan blades can crush & dismember.

**WARNING**

The PTO Driveline MUST be measured and cut (if required) as per the Owner's Manual. Failure to do so will result in damage to both the tractor and the implement.

**MechMaxx 3 POINT SNOW BLOWER**  
RELIABLE EFFICIENT VALUE

Model: \_\_\_\_\_ Weight: \_\_\_\_\_  
Working Width: \_\_\_\_\_ PTO Speed: \_\_\_\_\_  
Working Height: \_\_\_\_\_ Hitch Type: \_\_\_\_\_  
Year of MFG: \_\_\_\_\_  
Serial Number: \_\_\_\_\_  
www.mechmaxx.com

**DANGER**

**AVOID INJURY OR DEATH**

- Keep hands, feet, and clothing away from the rotating auger.
- Do not reach, touch, or lean over the auger while the engine is running.
- ONLY use the control bar to lower the auger. NEVER use hands or body weight.
- Do not attempt to clean, grease, and adjust the auger in gear while the engine is running.
- Do not stand on the auger while it is running.
- ONLY trained adults may operate the auger.

**DANGER**

**ROTATING DRIVELINE CONTACT CAN CAUSE DEATH. KEEP AWAY! DO NOT OPERATE WITHOUT:**

- All driveline guards, tractor, and equipment shields in place.
- Drivelines securely attached at both ends.
- Driveline guards that turn freely on drivelines.

**WARNING**

**MUST ADD GEARBOX OIL BEFORE FIRST USE**

1 Gallon (1.28 Liter) of SAE 90 Gear Oil (SAE 90W)

**CAUTION**

To avoid injury or machine damage, operate only with a 540 RPM PTO.

**540 RPM ONLY**

**CAUTION**

**GREASE**

**TSB48 TSB72**  
**TSB50 TSB84**

## SPECIFICATIONS

Model	TSB48/48T	TSB60/60T	TSB72/72T	TSB84/84T
Cutting Width	48"	60"	72"	84"
Cutting Height	27 in			
Cutting Edge	1/2" x 4" Hardened bolt-on replacement			
Auger Diameter	17.5 in			
Auger Thickness	5/16 in			
Auger Tube Diameter	2 3/4 in			
Fan Type	4-Blade Fan Style			
Fan Diameter	24 in			
Fan Depth	7 in			
Fan Steel Thickness	13/32 in			
3-Point Hitch	CAT I & II			
PTO Speed	540 RPM			
Gearoil Capacity	Approximately 1.22 quart (1.15L)			
Gearoil Type Recommended	85W-90			



## MAINTENANCE AND STORAGE

Regular maintenance and lubrication

- Check/Tighten fasteners after the first 2 hours of use and every 10 hours.
- Check and adjust drive chain tension every 20 hours.
- Lubricate PTO shaft driveline every 20 hours.
- Oil drive chain every 10 hours.
- Check gearbox oil every 20 hours.
- Check safety shields before each use.
- Lubricate the bearings #1 & #2(see picture) every 50 hours,

1. Bearing lubricator
2. Bearing lubricator
3. Cap for inlet gearbox oil
4. Cap for gearbox oil level
5. Cap for discharge gearbox oil

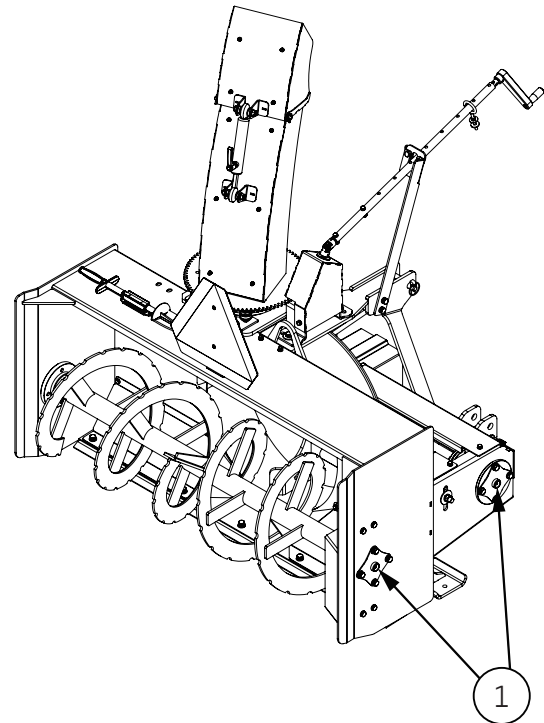

### STORAGE

At the end of the working season or when the snow blower will not be used for a long period, it is a good practice to clean off any dirt or salt that may have accumulated on the snow blower and any of the moving parts. Apply a coat of oil to the chain to prevent rust.



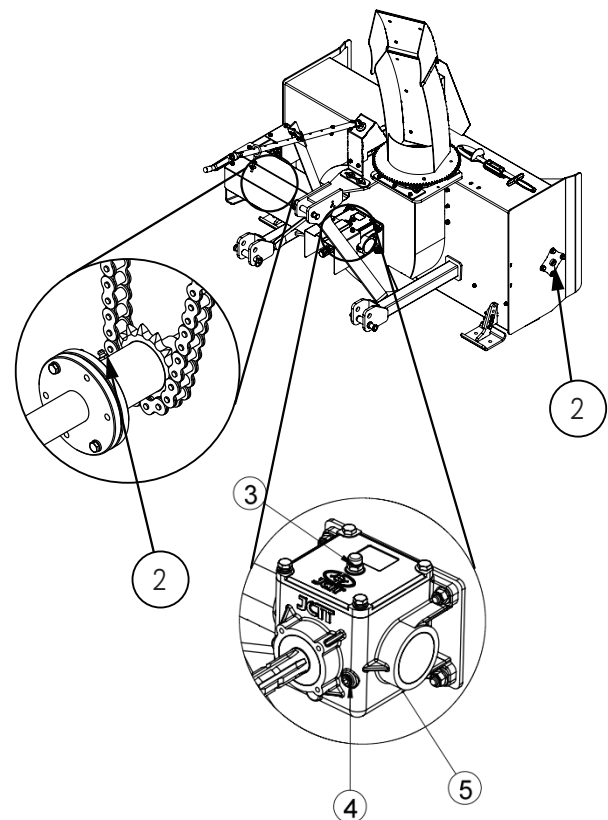



- Detach and store the snow blower in an area where children normally do not play.
- Clean as necessary.
- Check cutting blade for wear and replace if necessary.
- Inspect snow blower for loose, damaged or worn parts and adjust or replace as needed.
- Do not forget to check the safety labels.
- Replace worn labels.
- Store unit inside for longer life.
- Alternatively, cover with a tarp to reduce exposure and prevent weather damage.
- Repaint parts where paint is worn or scratched to prevent rust.
- Storing the snow blower in freezing conditions after use may cause the fan & auger to freeze in place. This may result in breaking PTO shaft shear bolts upon startup.



## BOLT TORQUE

The tables shown below give correct torque values for various bolts and cap screws. Tighten all bolts to the torques specified unless otherwise noted. Check tightness of bolts periodically, using bolt torque chart as a guide. Replace hardware with the same strength bolt.

**TORQUE VALUES CHART FOR COMMON BOLT SIZES**

Bolt Size (Inches) in-tpi <sup>1</sup>	Bolt Head Identification						Bolt Size (Inches) mm x pitch <sup>4</sup>	Bolt Head Identification					
													
	N.m <sup>2</sup>	ft-lb <sup>3</sup>	N.m	ft-lb	N.m	ft-lb		N.m	ft-lb	N.m	ft-lb	N.m	ft-lb
1/4"-20	7.4	5.6	11	8	16	12	M5X0.8	4	3	6	5	9	7
1/4"-28	8.5	6	13	10	18	14	M6X1	7	5	11	8	15	11
5/16"-18	15	11	24	17	33	25	M8X 1.25	17	12	26	19	36	27
5/16"-24	17	13	26	19	37	27	M8X1	18	13	28	21	39	29
3/8" -16	27	20	42	31	59	44	M10X 1.5	33	25	52	39	72	53
3/8" -24	31	22	47	35	67	49	M10X0.75	39	29	61	45	85	62
7/16" -14	43	32	67	49	95	70	M12X 1.75	58	42	91	67	125	93
7/16"-20	49	36	75	55	105	78	M12X 1.5	60	44	95	70	130	97
1/2" -13	66	49	105	76	145	105	M12X1	90	66	105	77	145	105
1/2" -20	75	55	115	85	165	120	M14 X2	92	68	145	105	200	150
9/16"-12	95	70	150	110	210	155	M14 X 1.5	99	73	155	115	215	160
9/16"-18	105	79	165	120	235	170	M16X2	145	105	225	165	315	230
5/8" - 11	130	97	205	150	285	210	M16X 1.5	155	115	240	180	335	245
5/8" -18	150	110	230	170	325	240	M18 X 2.5	195	145	310	230	405	300
3/4" -10	235	170	360	265	510	375	M18 X 1.5	220	165	350	260	485	355
3/4" -16	260	190	405	295	570	420	M20 X 2.5	280	205	440	325	610	450
7/8" -9	225	165	585	430	820	605	M20 X 1.5	310	230	650	480	900	665
7/8" -14	250	185	640	475	905	670	M24X3	480	355	760	560	1050	780
1"-8	340	250	875	645	1230	910	M24 X2	525	390	830	610	1150	845
1"-12	370	275	955	705	1350	995	M30 X 3.5	960	705	1510	1120	2100	1550
1-1/8"-7	480	355	1080	795	1750	1290	M30x2	1060	785	1680	1240	2320	1710
1-1/8" -12	540	395	1210	890	1960	1440	M36 X3.5	1730	1270	2650	1950	3660	2700
1-1/4"-7	680	500	1520	1120	2460	1820	M36X2	1880	1380	2960	2190	4100	3220
1-1/4" -12	750	555	1680	1240	2730	2010							
1-3/8"-6	890	655	1990	1470	3230	2380							
1-3/8" -12	1010	745	2270	1670	3680	2710							
1-1/2" -6	1180	870	2640	1950	4290	3160							
1-1/2" -12	1330	980	2970	2190	4820	3560							

Torque tolerance +0%,-15% of torquing values. Unless otherwise specified use torque values listed above.

Torque figures indicated above are valid for non-greased or non-oiled threads and heads otherwise specified. Therefore, do not grease or oil bolts or cap screws unless otherwise specified in this manual. When using locking elements, increase torque values by 5%.



## TROUBLESHOOTING

PROBLEM	SOLUTION
Not Throwing Snow	<ul style="list-style-type: none"> <li>• Operate at full throttle (540 PTO rpm), check PTO speed and tractor engine.</li> <li>• Shift transmission to a lower gear.</li> <li>• Discharge chute is plugged. Clear chute.</li> </ul>
Excessive Vibration	<ul style="list-style-type: none"> <li>• Discharge fan blade is bent or missing.</li> </ul>
Gearbox Noisy	<ul style="list-style-type: none"> <li>• Check oil level.</li> </ul>
Auger is Not Turning	<ul style="list-style-type: none"> <li>• Check the chain and transmissions.</li> </ul>
Tractor Loaded Down by Blower	<ul style="list-style-type: none"> <li>• Operate at full throttle (540 PTO rpm), check PTO speed and tractor engine.</li> <li>• Shift to a lower gear. Reduce tractor speed.</li> </ul>



**CAUTION**

**DO NOT try to clear discharge chute when tractor is running. Bodily harm may occur!**



PARTS DIAGRAM (SNOW BLOWER)

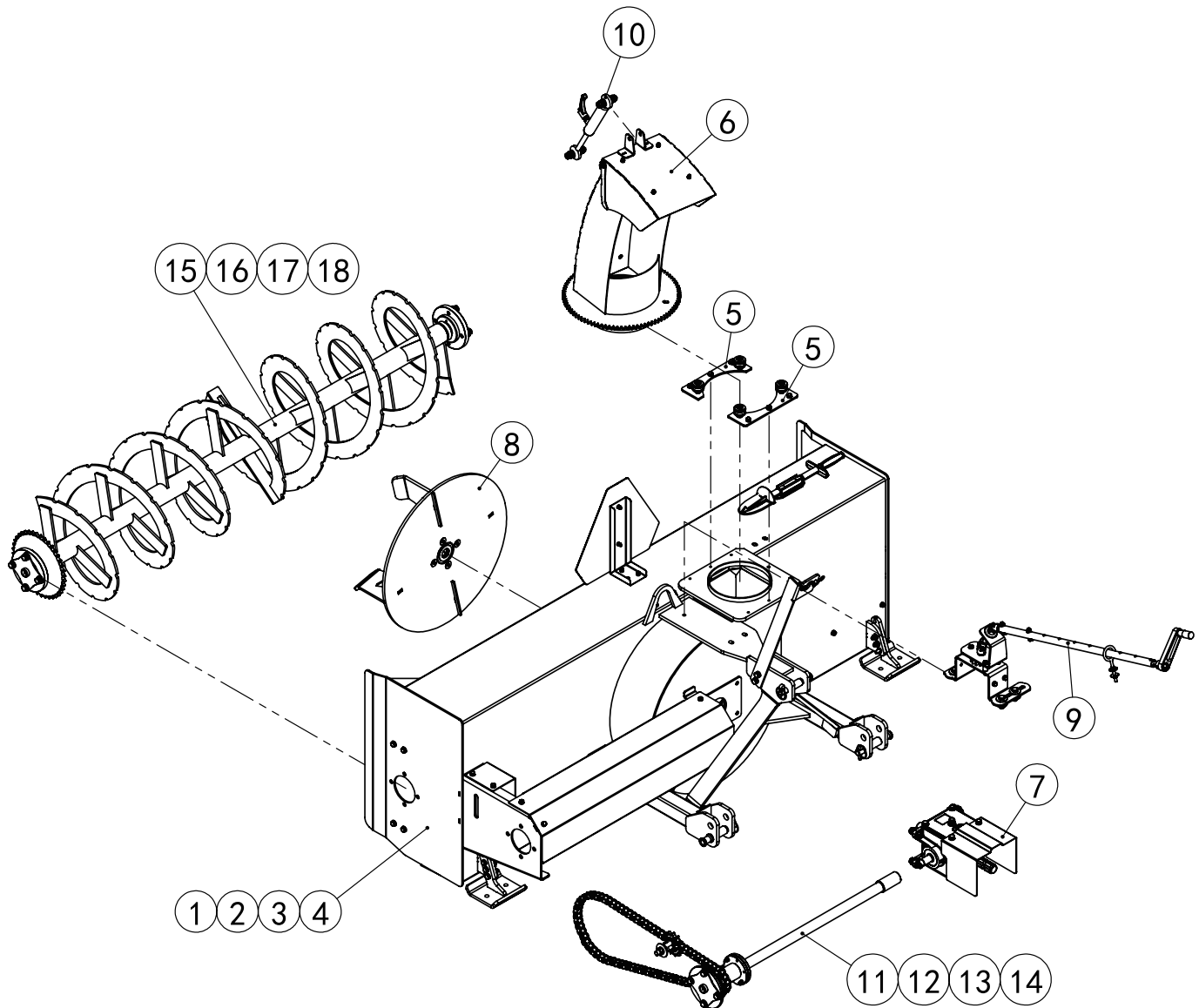

## PARTS LIST (SNOW BLOWER)

POS.	Description	Specification	120-Qty	150-Qty	180-Qty	210-Qty
1	Bucket assembly	BP120-01	1	-	-	-
2	Bucket assembly	BP150-01	-	1	-	-
3	Bucket assembly	BP180-01	-	-	1	-
4	Bucket assembly	BP210-01	-	-	-	1
5	Pressboard assembly	BP180-02	2	2	2	2
6	Outfeed assembly	BP180-03	1	1	1	1
7	Gearbox as-rear	BP180-04	1	1	1	1
8	Fan assembly	BP180-05	1	1	1	1
9	Handle as-hand	BP180-14	1	1	1	1
10	Handle as-hand	BP180-15	1	1	1	1
11	Drive assembly	BP120-07	1	-	-	-
12	Drive assembly	BP150-07	-	1	-	-
13	Drive assembly	BP180-07	-	-	1	-
14	Drive assembly	BP210-07	-	-	-	1
15	Stirring assembly	BP120-06	1	-	-	-
16	Stirring assembly	BP150-06	-	1	-	-
17	Stirring assembly	BP180-06	-	-	1	-
18	Stirring assembly	BP210-06	-	-	-	1

## PARTS DIAGRAM (BUCKET ASSEMBLY)

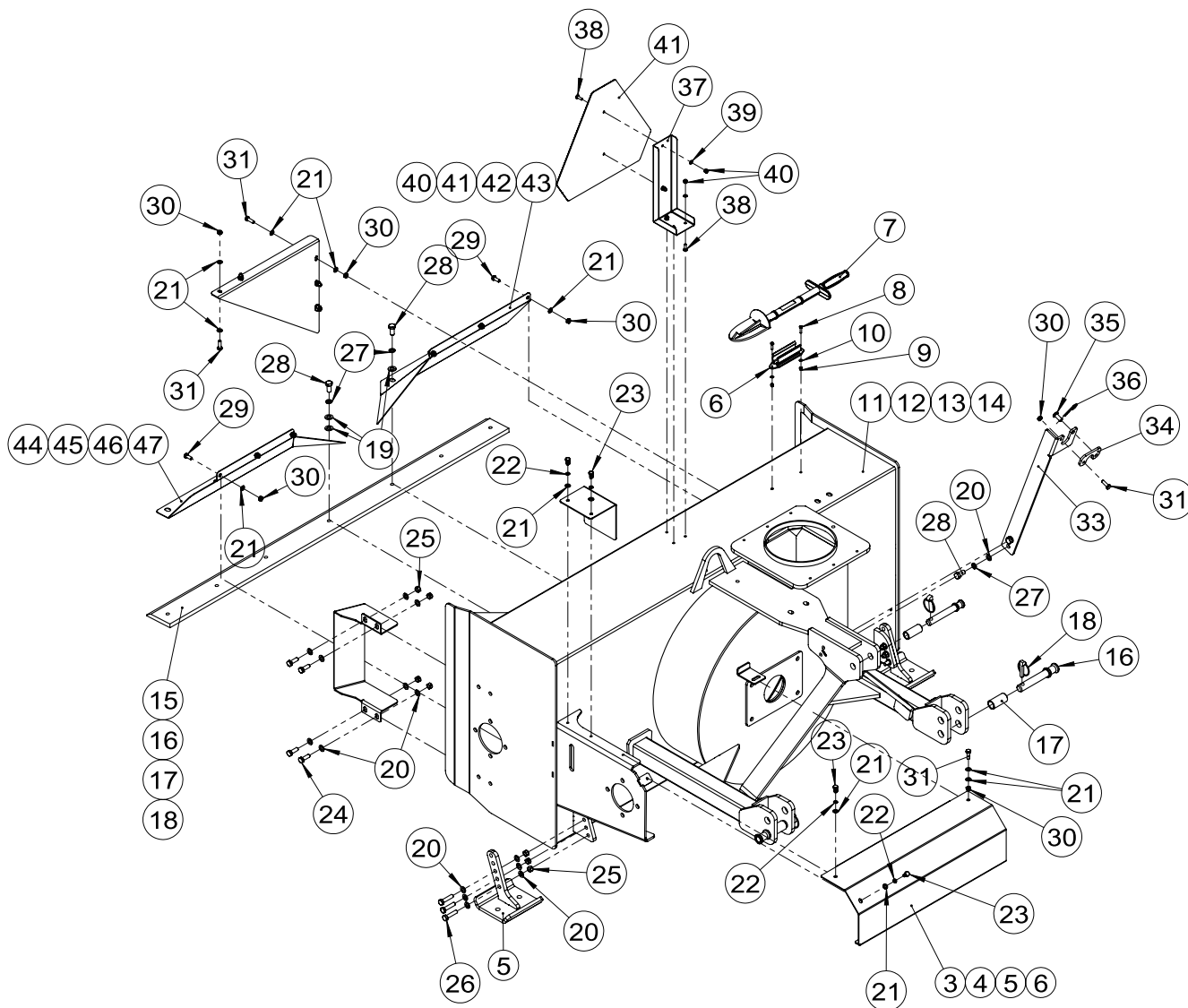

## PARTS LIST (BUCKET ASSEMBLY)

POS.	Description	Specification	120-Qty	150-Qty	180-Qty	210-Qty
1	Retroreflector	350mm×2mm-2-Φ7×156mm	1	1	1	1
2	Triangular baffle	BP180-103	1	1	1	1
3	Drive shaft cover	BP120-102	1	-	-	-
4	Drive shaft cover	BP150-102	-	1	-	-
5	Drive shaft cover	BP180-102	-	-	1	-
6	Drive shaft cover	BP210-102	-	-	-	1
7	Front baffle	BP180-100	1	1	1	1
8	Retroreflector Mounting Bracket	BP180-119	1	1	1	1
9		BP180-117	1	1	1	1
10	Leg weldment	BP180-002	2	2	2	2
11	Hood weldment	BP120-001	1	-	-	-
12	Hood weldment	BP150-001	-	1	-	-
13	Hood weldment	BP180-001	-	-	1	-
14	Hood weldment	BP210-001	-	-	-	1
15	Blade	BP120-201-B	1	-	-	-
16	Blade	BP150-201-B	-	1	-	-
17	Blade	BP180-201-B	-	-	1	-
18	Blade	BP210-201-B	-	-	-	1
19	Sprocket cover	BP180-101	1	1	1	1
20	Clevis Pin with Head Type B	GB_T882-Φ10×25-EP-Zn	1	1	1	1
21	Linch Pins	DIN 11023-10X45-EP-Zn	3	3	3	3
22	Spring Cotters	Φ3×50EP_Zn	1	1	1	1
23	Upper Suspension Pin Type I	BP180-202	1	1	1	1
24	suspension pin shaft spacer	BP180-229	1	1	1	1
25	Lower Suspension Pin Type I	BP180-203	2	2	2	2
26	Lower suspension pin shaft spacer	BP180-204	2	2	2	2
27	Hexagon Head Bolt -Full Thread	GB_T5783-M10×30-8.8-EP-Zn	4	4	4	4
28	Hexagon Head Bolt - Full Thread	GB_T5783-M10×45-8.8-EP-Zn	6	6	6	6
29	Hexagon Head Bolt- Full Thread	GB_T5783-M12×25-8.8-EP-Zn	7	9	9	11

POS.	Description	Specification	120-Qty	150-Qty	180-Qty	210-Qty
30	Hexagon Head Bolt - Full Thread	GB_T5783-M5x20-8.8-EP-Zn	2	2	2	2
31	Hexagon Head Bolt - Full Thread	GB_T5783-M8x16-8.8-EP-Zn	4	4	4	4
32	Hexagon Head Bolt - Full Thread	GB_T5783-M8x20-8.8-EP-Zn	4	6	6	8
33	Hexagon Head Bolt - Full Thread	GB_T5783-M8x25-8.8-EP-Zn	7	7	7	7
34	Hexagon Socket Button Head Screws with Collar	GB_T70.2-M6x20-A4	5	5	5	5
35	Plain Washer	GB_T95-10x2-EP_Zn	23	23	23	23
36	Plain Washers	GB_T95-12x2.5-EP_Zn	6	8	8	10
37	Plain Washer	GB_T95-5x1-EP_Zn	2	2	2	2
38	Plain Washers	GB_T95-6-EP_Zn	5	5	5	5
39	Plain Washer	GB_T95-8-EP_Zn	24	28	28	32
40	Snow protection reinforcing plate	BP120-104	1	-	-	-
41	Snow protection reinforcing plate	BP150-104	-	1	-	-
42	Snow protection reinforcing plate	BP180-104	-	-	1	-
43	Snow protection reinforcing plate	BP210-104	-	-	-	1
44	Snow protection reinforcing plate	BP120-105	1	-	-	-
45	Snow protection reinforcing plate	BP150-105	-	1	-	-
46	Snow protection reinforcing plate	BP180-105	-	-	1	-
47	Snow protection reinforcing plate	BP210-105	-	-	-	1
48	Latch	BP180-118	1	1	1	1
49	Spring washer	GB_T93-8x2.1-EP_Zn	4	4	4	4
50	Spring washer	GB_T93-12x3.1-EP_Zn	7	9	9	11
51	Rubber	BP180-205	1	1	1	1
52	Rubber	BP180-206	1	1	1	1
53	Prevailing torque type hexagon nut	GB_T889.1-M10-8-EP_Zn	10	10	10	10
54	Prevailing torque type hexagon nut	GB_T889.1-M5-8-EP_Zn	2	2	2	2
55	Prevailing torque type hexagon nut	GB_T889.1-M6-8-EP_Zn	5	5	5	5
56	Prevailing torque type hexagon nut	GB_T889.1-M8-8-EP_Zn	11	13	13	15



**PARTS DIAGRAM (PRESSBOARD ASSEMBLY)**

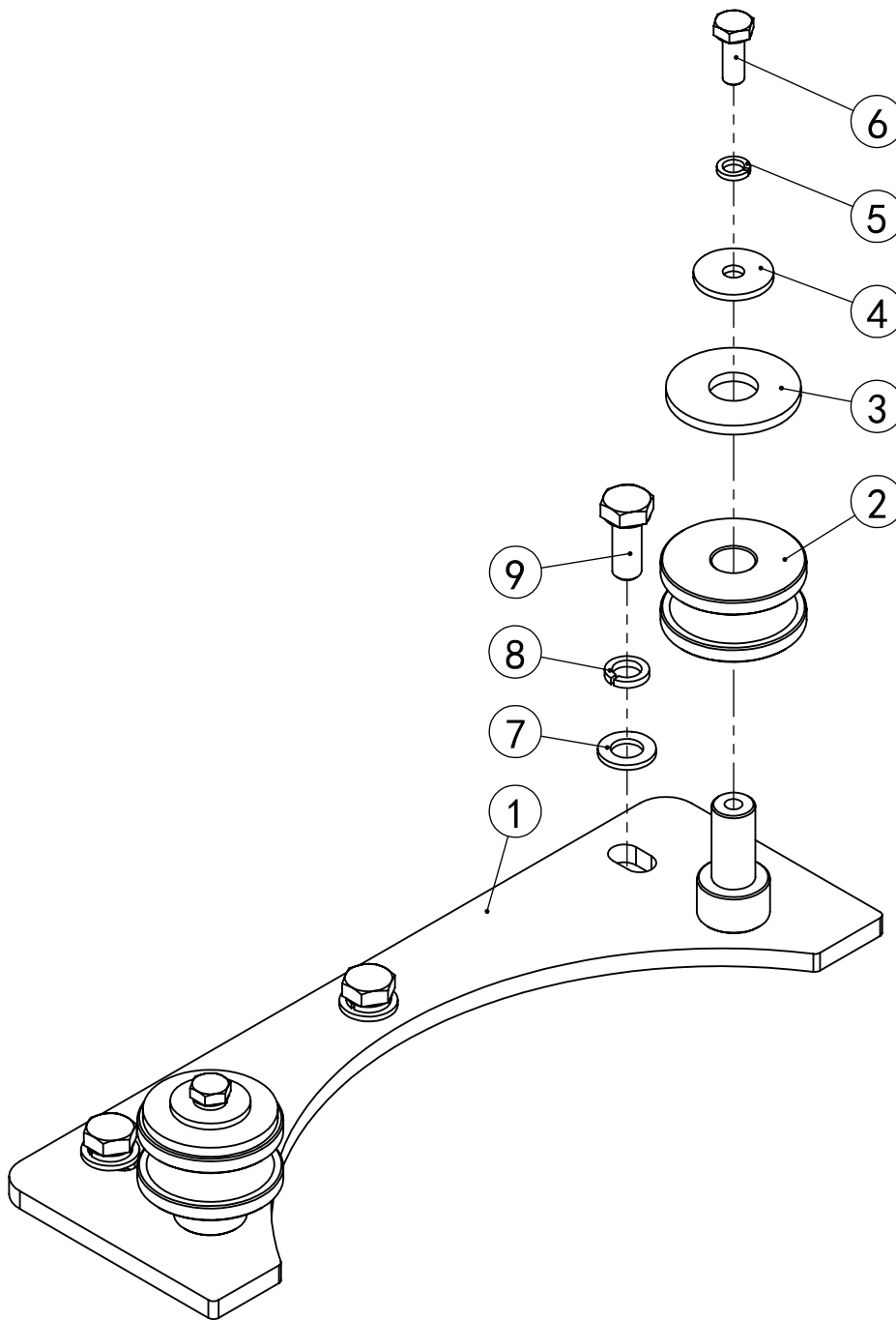

**PARTS LIST (PRESSBOARD ASSEMBLY)**

POS.	Description	Specification	Qty
1	Press plate weldment	BP180-003	1
2	Pulley	BP180-207	2
3	Plain Washers - Large Series	GB_T96.2-12-A4	2
4	Extra Large plain washer	GB_T5287-6-EP_Zn	2
5	Spring washer	GB_T93-6×1.6-EP_Zn	2
6	Hexagon Head Bolt - Full Thread	GB_T5783-M6x16-8.8-EP-Zn	2
7	Plain Washer	GB_T95-8-EP_Zn	3
8	Spring washer	GB_T93-8x2.1-EP_Zn	3
9	Hexagon Head Bolt - Full Thread	GB_T5783-M8x20-8.8-EP-Zn	3

**PARTS DIAGRAM (OUTFEED ASSEMBLY)**

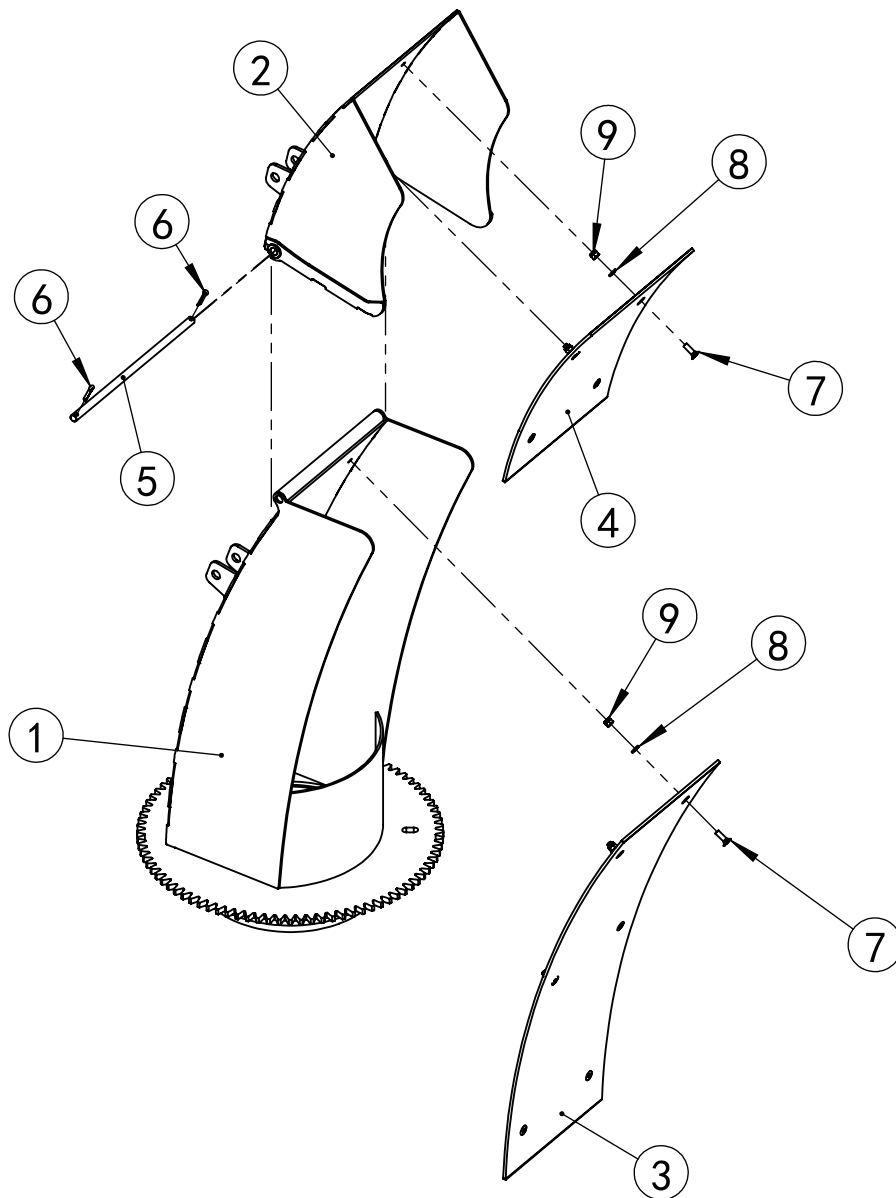

**PARTS LIST (OUTFEED ASSEMBLY)**

POS.	Description	Specification	Qty
1	Welding parts of snow discharge cylinder	BP180-004	1
2	Flap weldment	BP180-005	1
3	Back panel veneer	BP180-106	1
4	Flap cover plate	BP180-107	1
5	Install pin	BP180-208	1
6	Split Pins	GB_T91-4x20-EP_Zn_C	2
7	Hexagon Socket Countersunk Head Screw	GB_T70.3-M6x20-8.8-EP_Zn	10
8	Plain Washers	GB_T95-6-EP_Zn	10
9	Prevailing torque type hexagon nut	GB_T889.1-M6-8-EP_Zn	10



**PARTS DIAGRAM (GEARBOX AS-REAR)**

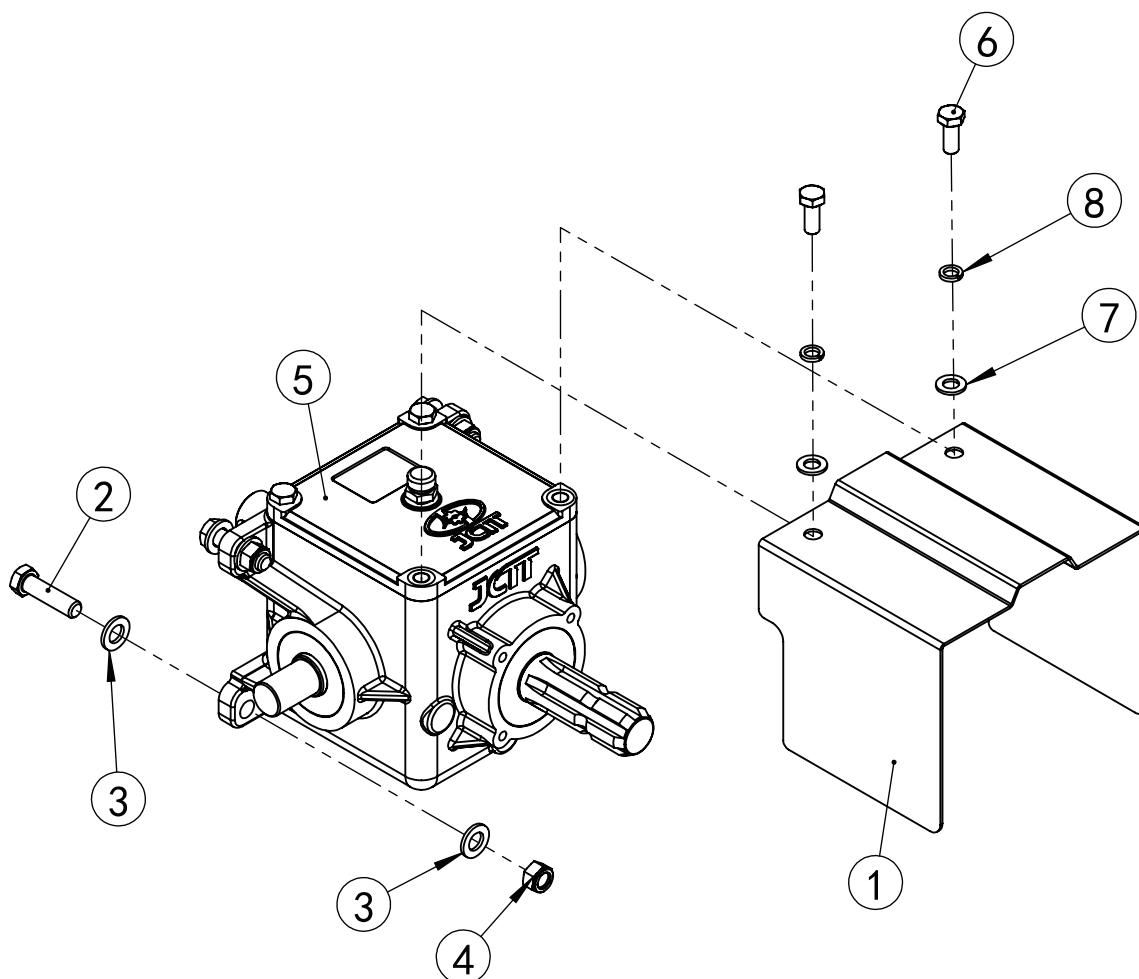

**PARTS LIST (GEARBOX AS-REAR)**

POS.	Description	Specification	Qty
1	Gear case cover	BP180-108	1
2	Hexagon Head Bolt - Full Thread	GB_T5783-M12x45-8.8-EP-Zn	4
3	Plain Washers	GB_T95-12x2.5-EP_Zn	8
4	Prevailing torque type hexagon nuts	GB_T889.1-M12-8-EP_Zn	4
5	Gear box	XH38.100J.01W	1
6	Hexagon Head Bolt -Full Thread	GB T5783-M10x25-8.8-EP-Zn	2
7	Plain Washer	GB_T95-10x2-EP_Zn	2
8	Spring washer	GB_T93-10x2.6-EP_Zn	2



**PARTS DIAGRAM (FAN ASSEMBLY)**

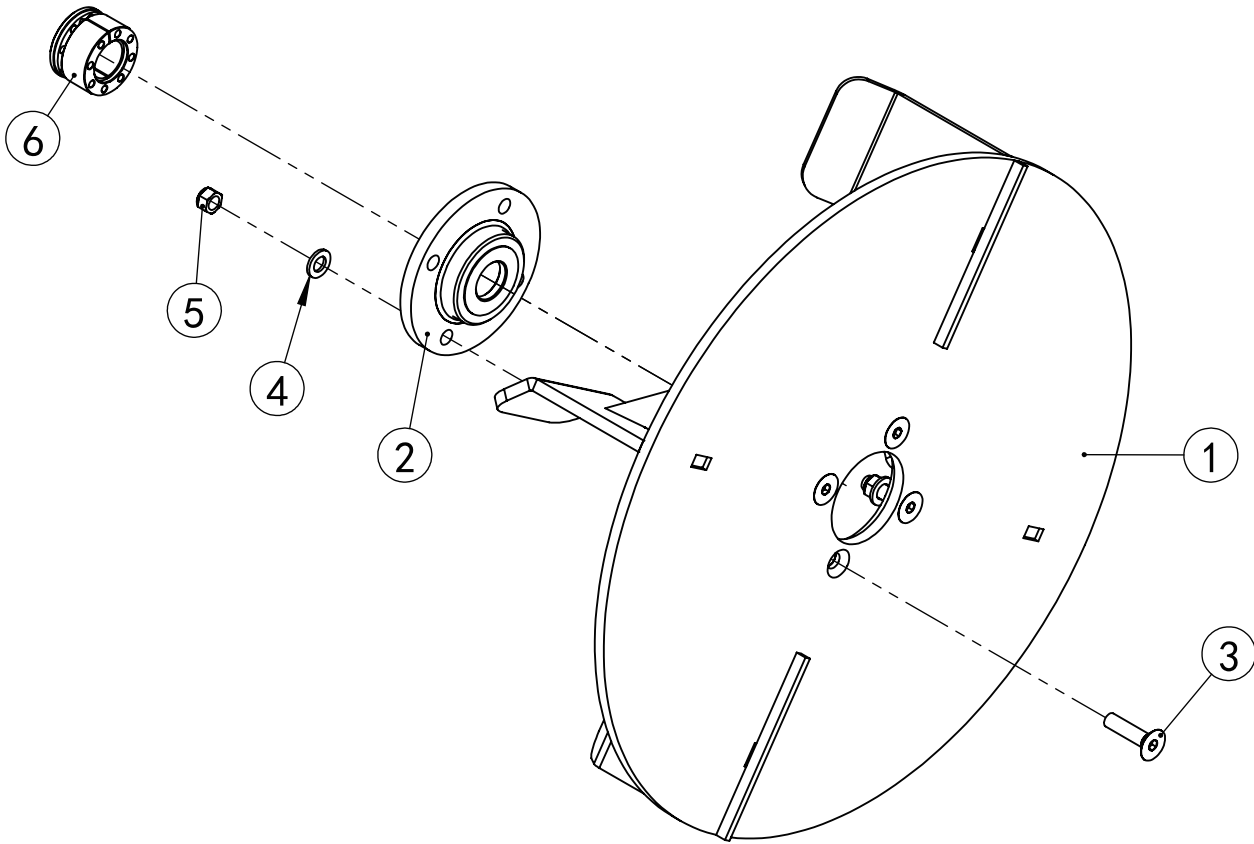

**PARTS LIST (FAN ASSEMBLY)**

POS.	Description	Specification	Qty
1	Fan weldment	BP180-006	1
2	Install the sleeve weldment	BP180-007	1
3	Hexagon Socket Countersunk Head Screw	GB_T70.3-M12x50-8.8-EP_Zn	4
4	Plain Washers	GB_T95-12x2.5-EP_Zn	4
5	Prevailing torque type hexagon nuts	GB_T889.1-M12-8-EP_Zn	4
6	Expanding sleeve	Z3A-33x60	1

**PARTS DIAGRAM (STIRRING ASSEMBLY)**

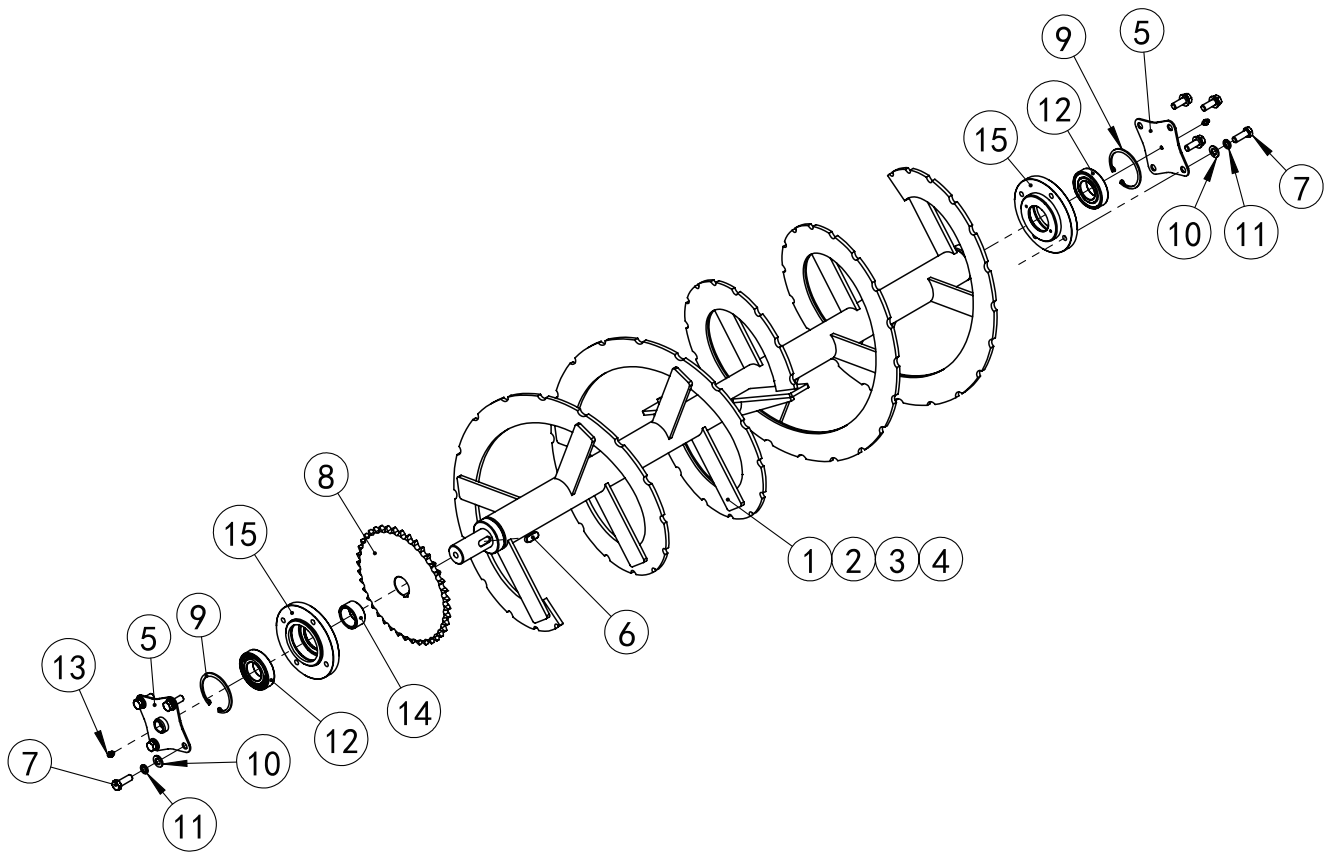

**PARTS LIST (STIRRING ASSEMBLY)**

POS.	Description	Specification	120-Qty	150-Qty	180-Qty	210-Qty
1	Stir up welding parts	BP120-008	-	-	1	-
2	Stir up welding parts	BP150-008	-	1	-	-
3	Stir up welding parts	BP180-008	1	-	-	-
4	Stir up welding parts	BP210-008	-	-	-	1
5	Mounting plate weldment	BP180-009	2	2	2	2
6	Square and rectangular key	GB_T1096-A12x8x32-EP_Zn	1	1	1	1
7	Hexagon Head Bolts - Full Thread	GB T5783-M12x35-8.8-EP-Zn	8	8	8	8
8	Chain wheel	BP180-210	1	1	1	1
9	Retaining rings for borP	GB_T893-80-A	2	2	2	2
10	Plain Washers	GB_T95-12x2.5-EP_Zn	8	8	8	8
11	Spring washer	GB_T93-12x3.1-EP_Zn	8	8	8	8
12	Deep groove ball bearing	GB_T276-6208-RS	2	2	2	2
13	Grease nipple	JB_T7940.1-M8x1	2	2	2	2
14	Bushing	BP180-211	1	1	1	1
15	Bearing steel seat	BP180-209	2	2	2	2



**PARTS DIAGRAM (HANDLE AS-HAND)**

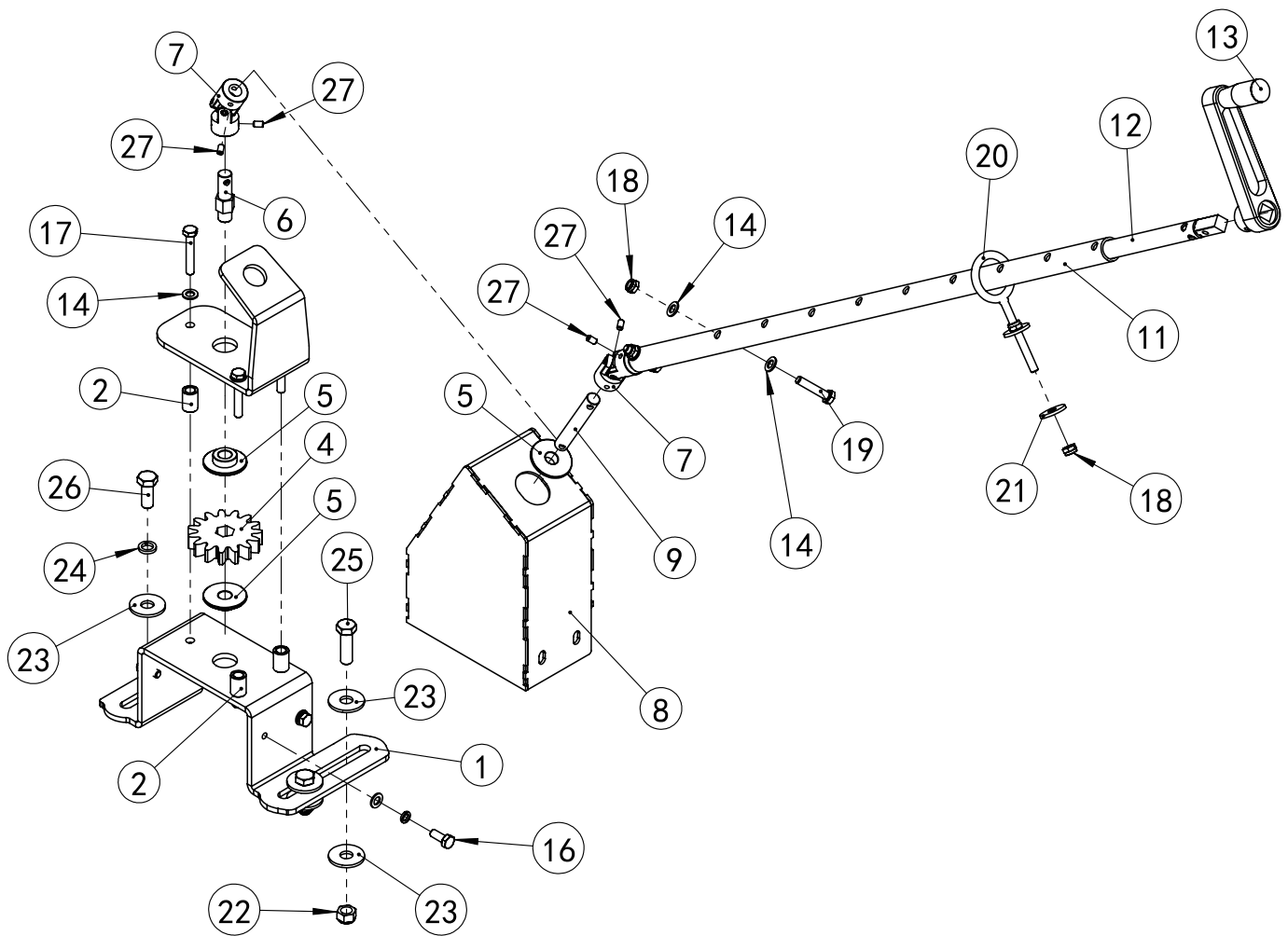

**PARTS LIST (HANDLE AS-HAND)**

POS.	Description	Specification	Qty
1	Handle mount	BP180-115	1
2	Positioning sleeve	BP180-222	3
3	Hand support plate	BP180-116	1
4	Gear	BP180-223	1
5	Rotary spacer	BP180-224-B	3
6	Link bar	BP180-225	1
7	Cardan	08G-Φ14×Φ28×L60-M6	2
8	Protective cover	BP180-010	1
9	Link bar	BP180-226	1
10	Link bar	BP180-227	1
11	Hand regulating tube	BP180-228	1
12	Adjusting rod weldment	BP180-011	1
13	Handle	NHXY-SB-18	1
14	Plain Washer	GB_T95-8-EP_Zn	13
15	Spring washer	GB_T93-8×2.1-EP_Zn	3
16	Hexagon Head Bolt - Full Thread	GB_T5783-M8x20-8.8-EP-Zn	3
17	Hexagon Head Bolt - Full Thread	GB_T5783-M8x50-8.8-EP-Zn	3
18	Prevailing torque type hexagon nut	GB_T889.1-M8-8-EP_Zn	7
19	Hexagon Head Bolt - Full Thread	GB_T5783-M8×50-8.8-EP-Zn	2
20	Eye Bolts	M8-80-Φ50×Φ36	1
21	Extra Large plain washer	GB_T5287-8-EP_Zn	2
22	Prevailing torque type hexagon nut	GB_T889.1-M12-8-EP_Zn	2
23	Plain Washers - Large Series	GB_T96.2-12-EP_Zn	5
24	Spring washer	GB_T93-12×3.1-EP_Zn	1
25	Hexagon Head Bolts - Full Thread	GB_T5783-M12x40-8.8-EP-Zn	2
26	Hexagon Head Bolts - Full Thread	GB_T5783-M12x30-8.8-EP-Zn	1
27	Hexagon socket screws with flat point	GB_T77-M6×10	4



**PARTS DIAGRAM (HANDLE AS-HAND)**

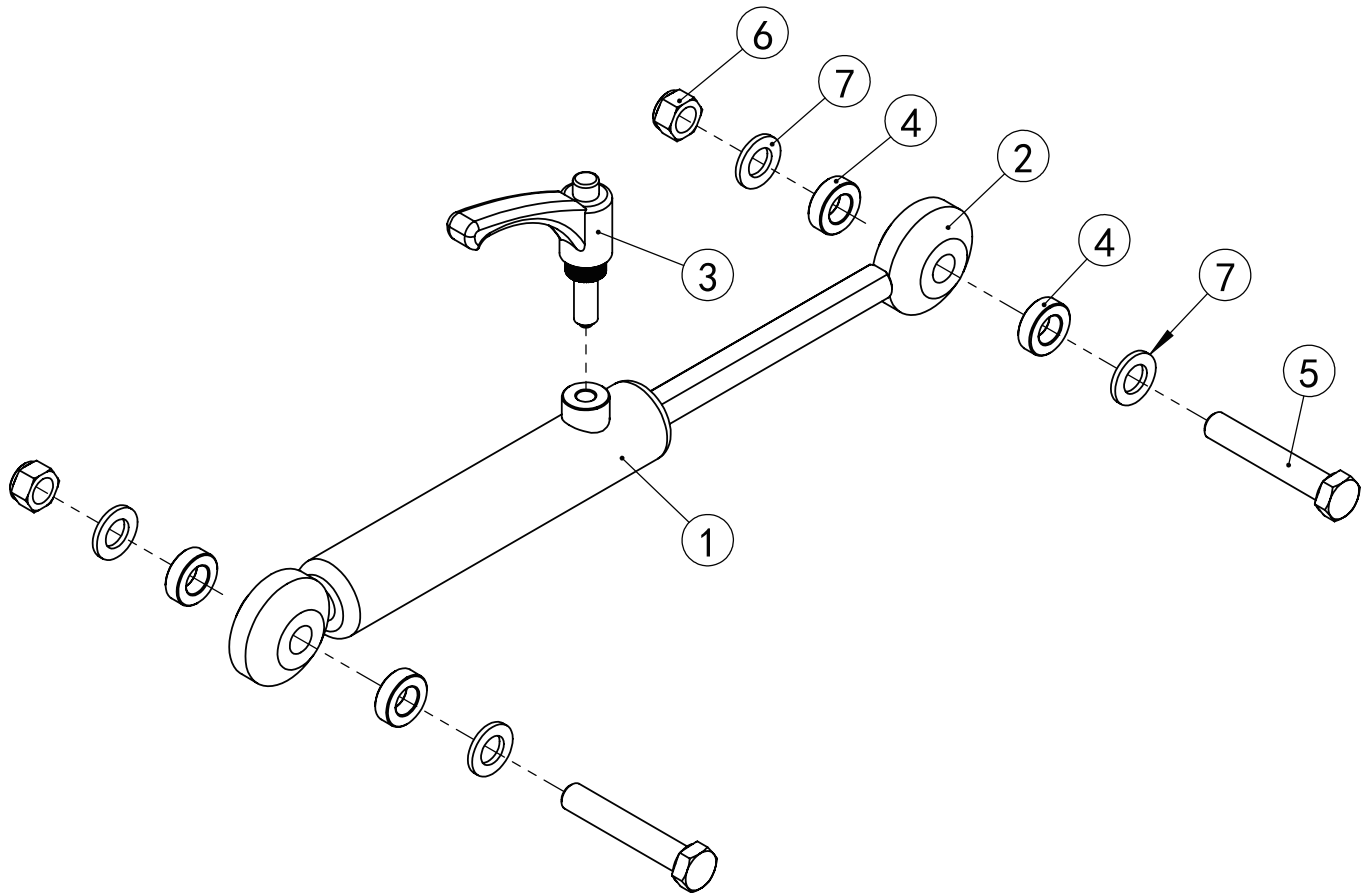

**PARTS LIST (HANDLE AS-HAND)**

POS.	Description	Specification	Qty
1	Manual Push-Cylinder Weldment	BP180-013	1
2	Manual Push Rod Weldment	BP180-012	1
3	Handles	M10×25	1
4	Bushing	BP180-219	4
5	Hexagon Head Bolt - Full Thread	GB_T5783-M12x70-8.8-EP-Zn	2
6	Prevailing torque type hexagon nuts	GB_T889.1-M12-8-EP_Zn	2
7	Plain Washers	GB_T95-12×2.5-EP_Zn	4

PARTS DIAGRAM (DRIVE ASSEMBLY)

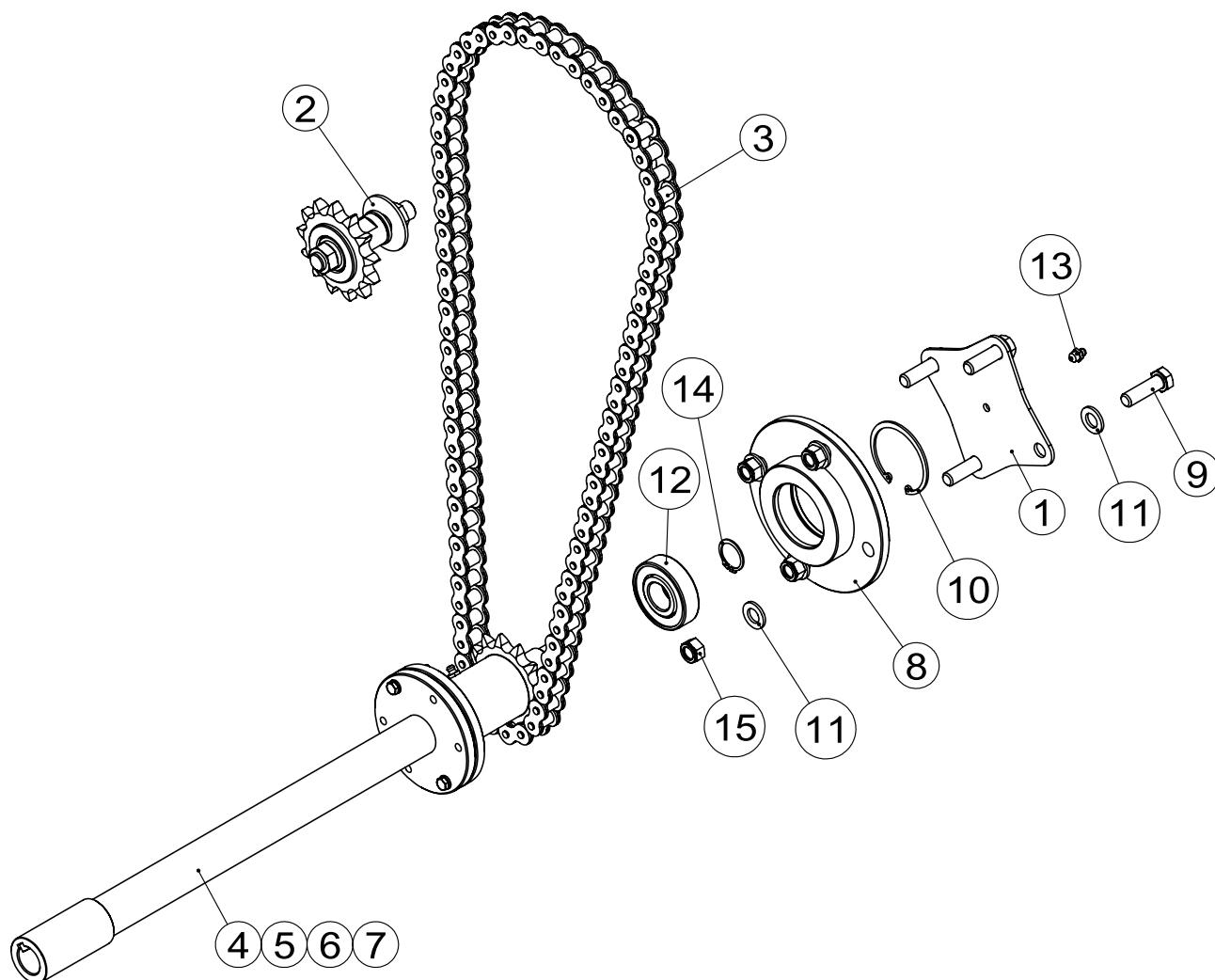

## PARTS LIST (DRIVE ASSEMBLY)

POS.	Description	Specification	120-Qty	150-Qty	180-Qty	210-Qty
1	Mounting plate weldment	BP180-009	1	1	1	1
2	Tensioner as	BP180-10	1	1	1	1
3	Roller chain	GB_T1243-12A-1×86	1	1	1	1
4	Drive as-torque limiter	BP120-09	1	-	-	-
5	Drive as-torque limiter	BP150-09	-	1	-	-
6	Drive as-torque limiter	BP180-09	-	-	1	-
7	Drive as-torque limiter	BP210-09	-	-	-	1
8	Drive shaft bearing seat	BP180-214	1	1	1	1
9	Hexagon Head Bolts - Full Thread	GB_T5783-M12×40-8.8-EP-Zn	4	4	4	4
10	Retaining rings for borP	GB_T893-62-A	1	1	1	1
11	Plain Washers	GB_T95-12x2.5-EP_Zn	8	8	8	8
12	Deep groove ball bearing	GB_T276-6305-RS	1	1	1	1
13	Grease nipple	JB_T7940.1-M8x1	1	1	1	1
14	Circlip for shaft-type	GB_T894-25-A	1	1	1	1
15	Prevailing torque type hexagon nuts	GB_T889.1-M12-8-EP_Zn	4	4	4	4

## PARTS DIAGRAM (DRIVE AS-TORQUE LIMITER)

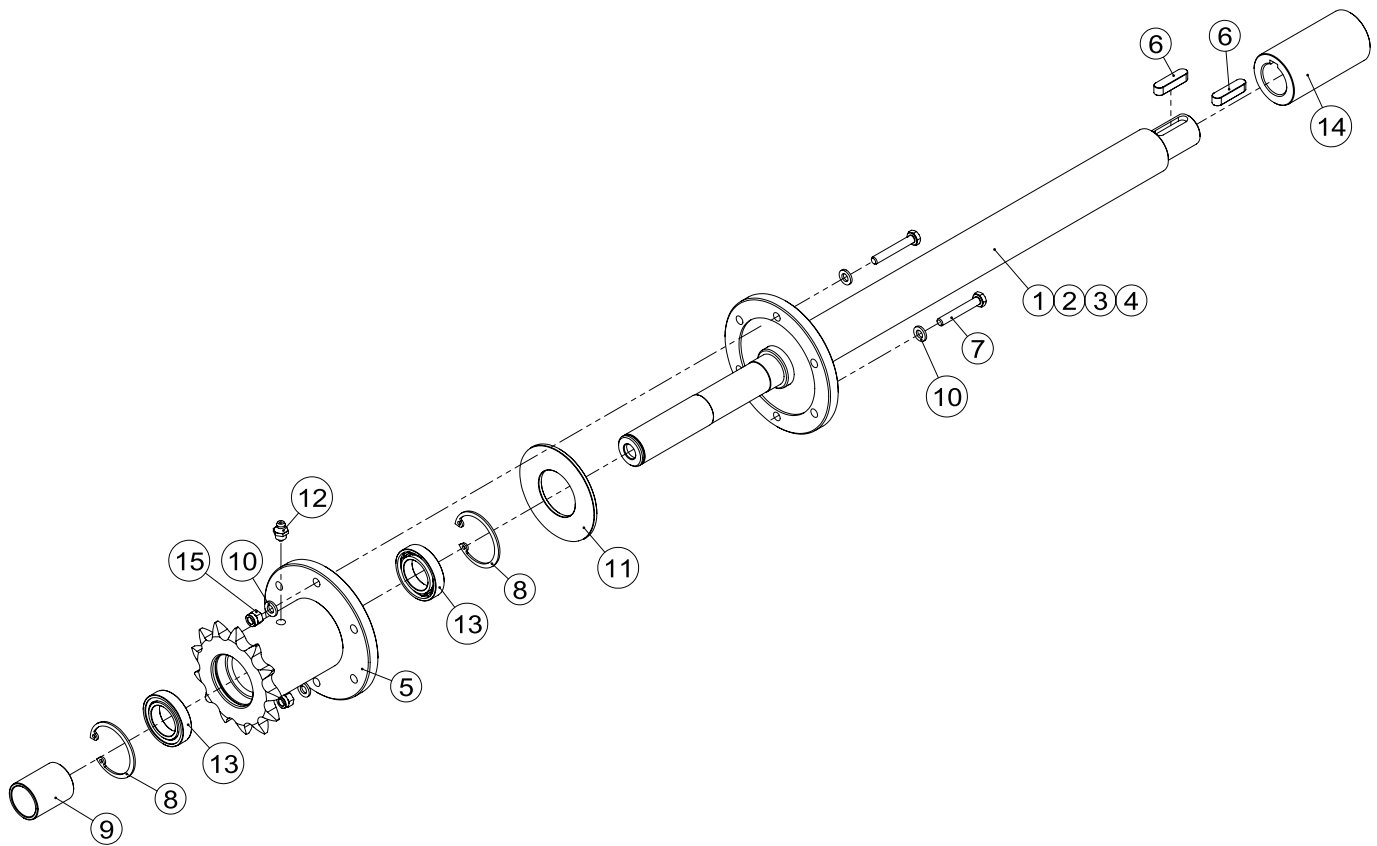

## PARTS LIST (DRIVE AS-TORQUE LIMITER)

POS.	Description	Specification	120-Qty	150-Qty	180-Qty	210-Qty
1	Transmission shaft	BP120-218	-	-	1	-
2	Transmission shaft	BP150-218	-	1	-	-
3	Transmission shaft	BP180-218	1	-	-	-
4	Transmission shaft	BP210-218	-	-	-	1
5	Chain wheel	BP180-215	1	1	1	1
6	Square and rectangular key	GB_T1096-A8x7x32-EP_Zn	2	2	2	2
7	Hexagon Head Bolt -Full Thread	GB_T5781-M6x40-4.8-EP-Zn	2	2	2	2
8	Retaining rings for borP	GB_T893-42-A	2	2	2	2
9	Sprocket bushing	BP180-217	1	1	1	1
10	Plain Washers	GB_T95-6-EP_Zn	4	4	4	4
11	Gasket (PTFE)	GB 78X38X3(PTFE)	1	1	1	1
12	Grease nipple	JB_T7940.1-M8x1	1	1	1	1
13	Deep groove ball bearing	GB_T276-61905-RS	2	2	2	2
14	connecting sleeve	BP180-216	1	1	1	1
15	Prevailing torque type hexagon nut	GB_T889.1-M6-8-EP_Zn	2	2	2	2

**PARTS DIAGRAM (TENSIONER ASSEMBLY)**

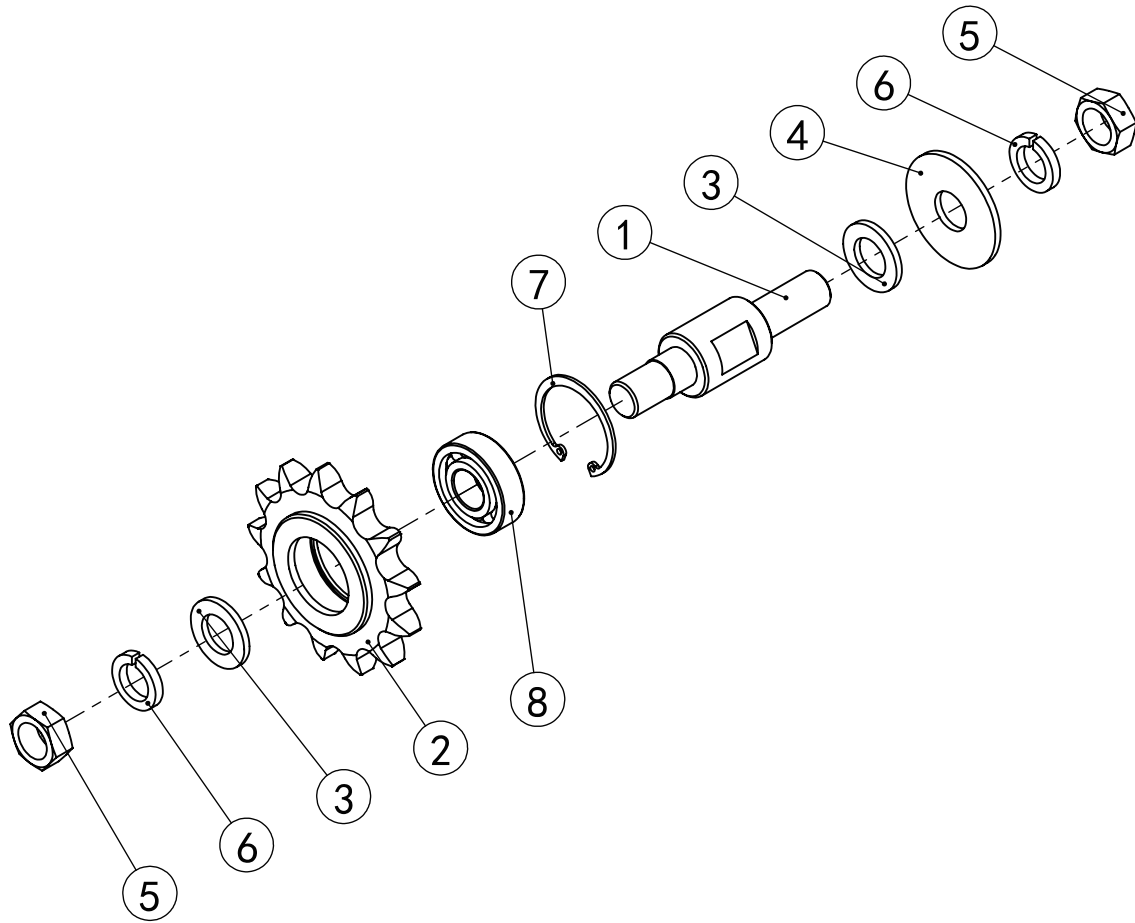

**PARTS LIST (TENSIONER ASSEMBLY)**

POS.	Description	Specification	Qty
1	Tighten axle	BP180-218	1
2	Chain wheel	BP180-219	1
3	Plain Washers	GB_T95-16x3-EP_Zn	2
4	Plain Washers - Large Series	GB_T96.2-16-EP_Zn	1
5	Hexagon Nut	GB_T41-M16-EP_Zn	2
6	Spring washer	GB_T93-16-EP_Zn	2
7	Retaining rings for bore	GB_T893-40-A	1
8	Deep groove ball bearing	GB_T276-6203-2RS	1

## PARTS DIAGRAM (HYDRAULIC RAM ASSEMBLY)

SOLD SEPARATELY, SKU:461033

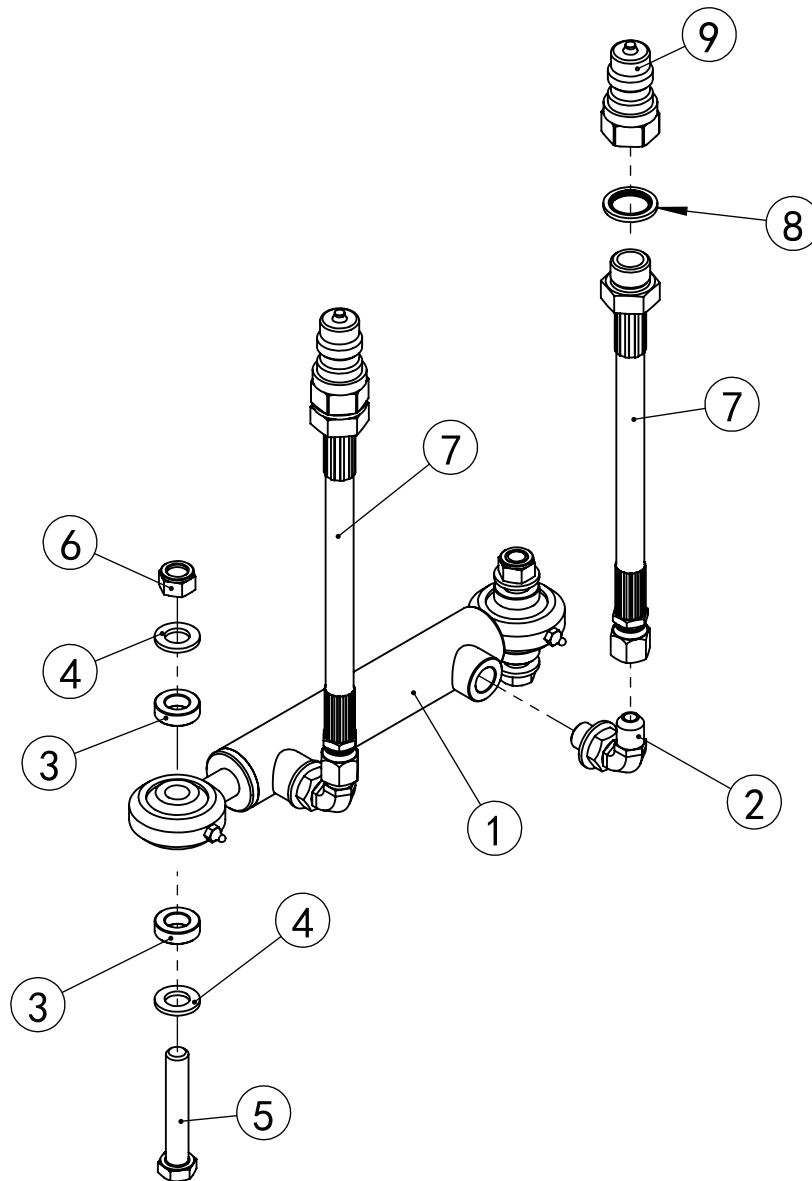

**PARTS LIST (HYDRAULIC RAM ASSEMBLY)**

SOLD SEPARATELY, SKU:461033

POS.	Description	Specification	Qty
1	Hydraulic cylinder	BP180-200	1
2	SAE6 fitting	9/16-18UNF	2
3	Bushing	BP180-219	4
4	Plain Washers	GB_T95-12×2.5-EP_Zn	4
5	Hexagon Head Bolt - Full Thread	GB_T5783-M12×70-8.8-EP-Zn	2
6	Prevailing torque type hexagon nuts	GB_T889.1-M12-8-EP_Zn	2
7	Hydraulic hose	BP180-221	2
8	Combination washer (self-centering)	BS / A21.50(G1/2)	2
9	Hydraulic quick coupling	H001G1/2	2

**PARTS DIAGRAM (CHUTE ADJUSTMENT HYDRAULIC)**

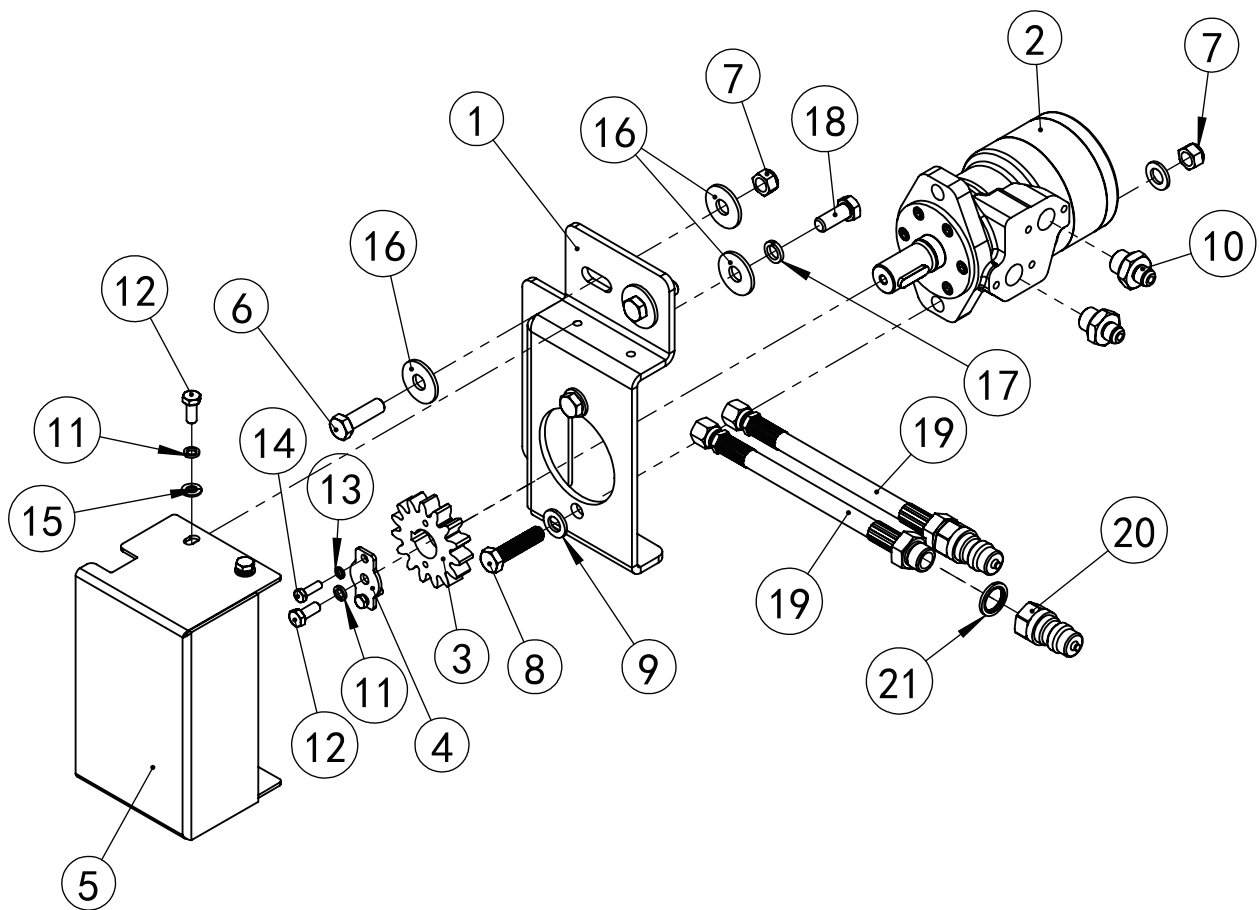

## PARTS LIST (CHUTE ADJUSTMENT HYDRAULIC)

POS.	Description	Specification	Qty
1	Hydraulic motor mounting seat	BP180-109	1
2	Motor	155160A6312AAAAAS	1
3	Gear for hydraulic mode	BP180-220	1
4	platen	BP180-110	1
5	Safety cover	BP180-111	1
6	Hexagon Head Bolts- Full Thread	GB_T5783-M12x40-8.8-EP-Zn	2
7	Prevailing torque type hexagon nut	GB_T889.1-M12-8-EP_Zn	4
8	Hexagon Head Bolts - Full Thread	GB_T5783-M12x50-8.8-EP-Zn	2
9	Plain Washers	GB_T95-12x2.5-EP_Zn	4
10	Transition joints	9/16-18UNF /G1/2	2
11	Spring washer	GB_T93-8x2.1-EP_Zn	5
12	Hexagon Head Bolt - Full Thread	GB_T5783-M8x20-8.8-EP-Zn	5
13	Spring washer	GB_T93-6x1.6-EP_Zn	2
14	Hexagon Head Bolts	GB_T5783-M6x20-8.8-EP-Zn	2
15	Plain Washer	GB_T95-8-EP_Zn	4
16	Plain Washers - Large Series	GB_T96.2-12-EP_Zn	5
17	Spring washer	GB_T93-12x3.1-EP_Zn	1
18	Hexagon Head Bolts-Full Thread	GB_T5783-M12x30-8.8-EP-Zn	1
19	Hydraulic hose	BP180-221	2
20	Hydraulic quick coupling	H001G1 /2	2
21	Combination washer (self-centering)	BS/ A21.50(G1/2)	2

**PARTS DIAGRAM (LIMIT PLATE ASSEMBLY)**

SOLD SEPARATELY, SKU:461033

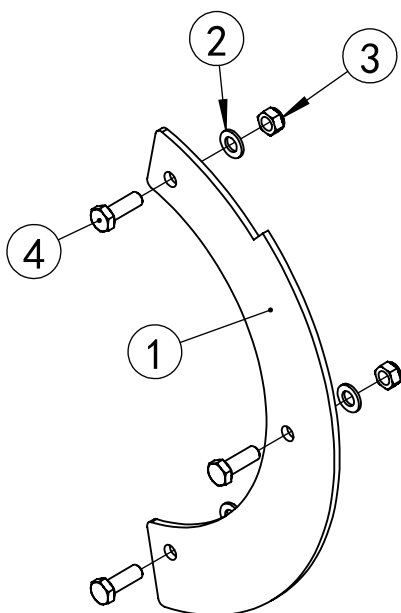

**PARTS LIST (LIMIT PLATE ASSEMBLY)**

SOLD SEPARATELY, SKU:461033

POS.	Description	Specification	Qty
1	Limiting plate	BP180-112	1
2	Plain Washer	GB_T95-10x2-EP_Zn	3
3	Prevailing torque type hexagon nut	GB_T889.1-M10-8-EP_Zn	3
4	Hexagon Head Bolt - Full Thread	GB_T5783-M10x30-8.8-EP-Zn	3





***MechMaxx***

[info@mechmaxx.com](mailto:info@mechmaxx.com)

