

Hisense

USE AND INSTALLATION INSTRUCTIONS

Factory model

AMW2-18U4RJC(AUS)

AMW3-24U4RJC(AUS)

AMW4-27U4RJC(AUS)

AMW4-36U4RAA(AUS)

AMW5-42U4RTA(AUS)

Market model

AMW2-52U4RJC

AMW3-71U4RJC

AMW4-80U4RJC

AMW4-100U4RAA

AMW5-125U4RTA

Thank you very much for purchasing this Air Conditioner. Please read this use and installation instructions carefully before installing and using this appliance and keep this manual for future reference.

Original instructions

Contents

Safety instructions	1
Installation instruction	9
Installation diagram	9
Transportation and handling before installation	9
Installation locations selection.....	9
Drainage elbow and drain hose installation	10
Outdoor unit installation	10
Refrigerant piping	11
Wiring	14
Trial run	17

NOTE:

- This heat pump air conditioner has been designed for the following temperatures. It should be operated within this range:

	Outdoor operation temperature range	
	Maximum (°C)	Minimum (°C)
Cooling Operation	48	-15
Heating Operation	24	-15

- Storage condition: Temperature -25~60°C
Humidity 30%~80%

Safety precautions

1. This air conditioner uses new refrigerant HFC (R32).
2. Since the max. working pressure is 4.3/4.15MPa (R22:3.1MPa), some of the piping and installation and service tools are special.
3. This air conditioner uses power supply: 220-240V ~, 50Hz.

Please read these SAFETY PRECAUTIONS carefully to ensure correct installation.

- Be sure to use a dedicated power circuit, and do not put other loads on the power supply.
- Be sure to read these SAFETY PRECAUTIONS carefully before installation.
- Be sure to comply with SAFETY PRECAUTIONS of installation manual, because it contains important safety issues. Definitions for identifying hazard levels are provide below with their respective safety symbols.

⚠ **WARNING:** Hazards or unsafe practices which COULD result in severe personal injury or death.

⚠ **CAUTION:** Hazards or unsafe practices which COULD result in minor personal injury or product or property damage.

- Please carefully file indoor and outdoor unit manual away for future reference.



- Installation should be performed by the qualified personnel.
Incomplete installation may cause damage by fire, electric shock, drop or water leakage.
- Perform the installation securely referring to the installation manual.
Incomplete installation could cause a personal injury due to fire, electric shock, the unit falling or leakage of water.
- Install the air conditioner on a solid base that can support the unit weight.
An inadequate base or incomplete installation may cause injury due to unit falling off from the base.
- Wiring must be done by the qualified electrician. All the electric works must be performed in accordance with national wiring regulations and local electrical codes.
- Use the specified type of wire for electrical connections safely.
Firmly clamp the interconnecting wires so that their terminals receive no external stresses.
- For wiring, use a cable long enough to cover the entire distance with no connection, and don't connect multiple devices to the same AC power supply.
Otherwise, it may be due to bad contact, poor insulation, exceed the allowable current and cause a fire or electric shock.
- After all installations are completed, check to make sure that no refrigerant leaking out occurs.
If the refrigerant gas leakage to the interior, and the heater, stove flame touching it, will generate harmful substances.
- If the power supply circuit capacity or electrical work is not in place, may cause a fire or electric shock.
- Attach the electrical cover to the indoor unit and the service panel to the outdoor unit securely.
- If the electrical covers on the indoor unit or the service panel of the outdoor unit are not attached securely, it could result in a fire or an electric shock due to dust water, etc.
- Please be sure to cut off the main power supply before the installation of indoor electronic PCB or wiring. Otherwise, it will cause electric shock.
- The outdoor machine installation location should pay attention to the protection, avoid people or other small animals contact with electrical components, please keep the outdoor unit of the surrounding environment clean and tidy.
- When installing or relocating the unit, make sure that no substance other than the specified refrigerant (R32) enters the refrigerant circuit.
Any presence of foreign substance such as air can cause abnormal pressure rise or an explosion.

Safety precautions



- Perform grounding
Does not connect the earth wire to a gas pipe, water pipe, lightning rod or telephone earth wire. Defective grounding could cause an electric shock.
- Do not install the unit in a place where an inflammable gas leaks.
If gas leaks and accumulates in the area surrounding the unit, it could cause an explosion.
- Fasten a flare nut with a torque wrench as specified in this manual.
When fastened too tight, a flare nut may break after a long period and cause a leakage of refrigerant.
- Install an earth leakage breaker depending on the installation place (where it is humid).
If an earth leakage breaker is not installed, it could cause an electric shock.
- Perform the drainage/ piping work securely according to the installation manual.
- If there is a defect in the drainage/piping work, water could drop from the unit and household goods could be wet and damaged.

Safety instructions

- Do not let air enter the refrigeration system or discharge refrigerant when moving the air conditioner.
- The installation instructions for appliances that are intended to be permanently connected to fixed wiring, and have a leakage current that may exceed 10mA, shall state that the installation of a residual current device (RCD) having a rated residual operating current not exceeding 30mA is advisable.
- This appliance is not intended for use by persons (including children) with reduced physical, sensory or mental capabilities, or lack of experience and knowledge, unless they have been given supervision or instruction concerning use of the appliance by a person responsible for their safety.
- If the supply cord is damaged, it must be replaced by the factory or its service department to avoid danger.
- Servicing shall only be performed as recommended by the equipment manufacturer.
- Maintenance and repair requiring the assistance of other skilled personnel shall be carried out under the supervision of the person competent in the use of flammable refrigerants.
- Means for disconnection, which can provide full disconnection in all poles, must be incorporated in the fixed wiring in accordance with the wiring rules.
- It is necessary to allow the disconnection of the appliance from the supply after installation. Make sure the disconnection of the appliance from the supply when service and maintenance, a disconnection with a locking system in the isolated position shall be provided.
- The method of connection of the appliance to the electrical supply and interconnection of separate components, and the wiring diagram with a clear indication of the connections and wiring to external control devices and supply cord are detailed below.
- Power connection and interconnection between outdoor unit and indoor unit should be conducted with the power cord of the H07RN-F type or the electrically equivalent type. The size of the power cord is detailed in outdoor unit manual below.
- Type and rating of circuit breakers / ELB are detailed below.
- The information on dimensions of the space necessary for correct installation of the appliance including the minimum permissible distances to adjacent structures is detailed below.
- This appliance is intended to be used by expert or trained users in shops, in light industry and on farms, or for commercial use by lay persons.
- In order to avoid a hazard due to inadvertent resetting of the thermal cut-out, this appliance must not be supplied through an external switching device, such as a timer, or connected to a circuit that is regularly switched on and off by the utility.
- Instructions on additional charging of refrigerants are detailed below.

Safety precautions

Precautions for using R32 refrigerant

The basic installation work procedures are the same as the conventional refrigerant (R22 or R410A). However, pay attention to the following points:

WARNING

1. Transport of equipment containing flammable refrigerants.

Attention is drawn to the fact that additional transportation regulations may exist with respect to equipment containing flammable gas. The maximum number of pieces of equipment or the configuration of the equipment, permitted to be transported together will be determined by the applicable transport regulations.

2. Marking of equipment using signs

Signs for similar appliances (containing flammable refrigerants) used in a work area generally are addressed by local regulations and give the minimum requirements for the provision of safety and/or health signs for a work location. All required signs are to be maintained and employers should ensure that employees receive suitable and sufficient instruction and training on the meaning of appropriate safety signs and the actions that need to be taken in connection with these signs.

The effectiveness of signs should not be diminished by too many signs being placed together. Any pictograms used should be as simple as possible and contain only essential details.

3. Disposal of equipment using flammable refrigerants

Compliance with national regulations

4. Storage of equipment/appliances

The storage of equipment should be in accordance with the manufacturer's instructions.

5. Storage of packed (unsold) equipment

- Storage package protection should be constructed such that mechanical damage to the equipment inside the package will not cause a leak of the refrigerant charge.
- The maximum number of pieces of equipment permitted to be stored together will be determined by local regulations.

6. Information on servicing

6-1 Checks to the area

Prior to beginning work on systems containing flammable refrigerants, safety checks are necessary to ensure that the risk of ignition is minimized. For repair to the refrigerating system, the following precautions should be complied with prior to conducting work on the system.

6-2 Work procedure

Work shall be undertaken under a controlled procedure so as to minimise the risk of flammable gas or vapour being present while the work is being performed.

6-3 General work area

- All maintenance staff and others working in the local area shall be instructed on the nature of work being carried out. Work in confined spaces shall be avoided.
- The area around the workspace shall be sectioned off. Ensure that the conditions within the area have been made safe by control of flammable material.

6-4 Checking for presence of refrigerant

- The area shall be checked with an appropriate refrigerant detector prior to and during work, to ensure the technician is aware of potentially flammable atmospheres.
- Ensure that the leak detection equipment being used is suitable for use with flammable refrigerants, i.e. non-sparking, adequately sealed or intrinsically safe.

6-5 Presence of fire extinguisher

- If any hot work is to be conducted on the refrigeration equipment or any associated parts, appropriate fire extinguishing equipment shall be available to hand.
- Have a dry powder or CO₂ fire extinguisher adjacent to the charging area.

6-6 No ignition sources

- No person carrying out work in relation to a refrigeration system which involves exposing any pipe work that contains or has contained flammable refrigerant shall use any sources of ignition in such a manner that it may lead to the risk of fire or explosion.
- All possible ignition sources, including cigarette smoking, should be kept sufficiently far away from the site of installation, repairing, removing and disposal, during which flammable refrigerant can possibly be released to the surrounding space.
- Prior to work taking place, the area around the equipment is to be surveyed to make sure that there are no flammable hazards or ignition risks. "No Smoking" signs shall be displayed.

6-7 Ventilated area

- Ensure that the area is in the open or that it is adequately ventilated before breaking into the system or conducting any hot work.
- A degree of ventilation shall continue during the period that the work is carried out.
- The ventilation should safely disperse any released refrigerant and preferably expel it externally into the atmosphere.

Safety precautions

WARNING

6-8 Checks to the refrigeration equipment

- Where electrical components are being changed, they shall be fit for the purpose and to the correct specification.
- At all times the manufacturer's maintenance and service guidelines shall be followed. If in doubt consult the manufacturer's technical department for assistance.
- The following checks shall be applied to installations using flammable refrigerants:
 - The charge size is in accordance with the room size within which the refrigerant containing parts are installed;
 - The ventilation machinery and outlets are operating adequately and are not obstructed;
 - If an indirect refrigerating circuit is being used, the secondary circuit shall be checked for the presence of refrigerant;
 - Marking to the equipment continues to be visible and legible. Markings and signs that are illegible shall be corrected;
 - Refrigeration pipe or components are installed in a position where they are unlikely to be exposed to any substance which may corrode refrigerant containing components, unless the components are constructed of materials which are inherently resistant to being corroded or are suitably protected against being so corroded.

6-9 Checks to electrical devices

- Repair and maintenance to electrical components shall include initial safety checks and component inspection procedures.
- If a fault exists that could compromise safety, then no electrical supply shall be connected to the circuit until it is satisfactorily dealt with.
- If the fault cannot be corrected immediately but it is necessary to continue operation, an adequate temporary solution shall be used.
- This shall be reported to the owner of the equipment so all parties are advised.
- Initial safety checks shall include:
 - That capacitors are discharged: this shall be done in a safe manner to avoid possibility of sparking;
 - That there no live electrical components and wiring are exposed while charging, recovering or purging the system;
 - That there is continuity of earth bonding.

7. Repairs to sealed components

- During repairs to sealed components, all electrical supplies shall be disconnected from the equipment being worked upon prior to any removal of sealed covers, etc.
- If it is absolutely necessary to have an electrical supply to equipment during servicing, then a permanently operating form of leak detection shall be located at the most critical point to warn of a potentially hazardous situation.
- Particular attention shall be paid to the following to ensure that by working on electrical components, the casing is not altered in such a way that the level of protection is affected.
- This shall include damage to cables, excessive number of connections, terminals not made to original specification, damage to seals, incorrect fitting of glands, etc.
- Ensure that apparatus is mounted securely.
- Ensure that seals or sealing materials have not degraded such that they no longer serve the purpose of preventing the ingress of flammable atmospheres.
- Replacement parts shall be in accordance with the manufacturer's specifications.

NOTE: The use of silicon sealants may inhibit the effectiveness of some types of leak detection equipment. Intrinsically safe components do not have to be isolated prior to working on them.

8. Repair to intrinsically safe components

- Do not apply any permanent inductive or capacitance loads to the circuit without ensuring that this will not exceed the permissible voltage and current permitted for the equipment in use.
- Intrinsically safe components are the only types that can be worked on while live in the presence of a flammable atmosphere. The test apparatus shall be at the correct rating.
- Replace components only with parts specified by the manufacturer.
- Other parts may result in the ignition of refrigerant in the atmosphere from a leak.

9. Cabling

- Check that cabling will not be subject to wear, corrosion, excessive pressure, vibration, sharp edges or any other adverse environmental effects.
- The check shall also take into account the effects of aging or continual vibration from sources such as compressors or fans.

Safety precautions

WARNING

10. Detection of flammable refrigerants

- Under no circumstances shall potential sources of ignition be used in the searching for or detection of refrigerant leaks.
- A halide torch (or any other detector using a naked flame) shall not be used.

11. Leak detection methods

The following leak detection methods are deemed acceptable for systems containing flammable refrigerants:

- Electronic leak detectors shall be used to detect flammable refrigerants, but the sensitivity may not be adequate, or may need re-calibration. (Detection equipment shall be calibrated in a refrigerant-free area.)
- Ensure that the detector is not a potential source of ignition and is suitable for the refrigerant used.
- Leak detection equipment shall be set at a percentage of the LFL of the refrigerant and shall be calibrated to the refrigerant employed and the appropriate percentage of gas (25 % maximum) is confirmed.
- Leak detection fluids are suitable for use with most refrigerants but the use of detergents containing chlorine shall be avoided as the chlorine may react with the refrigerant and corrode the copper pipe-work.
- If a leak is suspected, all naked flames shall be removed/ extinguished.
- If a leakage of refrigerant is found which requires brazing, all of the refrigerant shall be recovered from the system, or isolated (by means of shut off valves) in a part of the system remote from the leak.
- Oxygen free nitrogen (OFN) shall then be purged through the system both before and during the brazing process.

12. Removal and evacuation

- When breaking into the refrigerant circuit to make repairs – or for any other purpose –conventional procedures shall be used.
- However, it is important that best practice is followed since flammability is a consideration.
- The following procedure shall be adhered to:
 - Remove refrigerant;
 - Purge the circuit with inert gas;
 - Evacuate;
 - Purge again with inert gas;
 - Open the circuit by cutting or brazing.
- The refrigerant charge shall be recovered into the correct recovery cylinders.
- The system shall be “flushed” with OFN to render the unit safe.
- This process may need to be repeated several times.
- Compressed air or oxygen shall not be used for this task.
- Flushing shall be achieved by breaking the vacuum in the system with OFN and continuing to fill until the working pressure is achieved, then venting to atmosphere, and finally pulling down to a vacuum.
- This process shall be repeated until no refrigerant is within the system. When the final OFN charge is used, the system shall be vented down to atmospheric pressure to enable work to take place.
- This operation is absolutely vital if brazing operations on the pipe-work are to take place.
- Ensure that the outlet for the vacuum pump is not close to any ignition sources and there is ventilation available.

13. Charging procedures

- In addition to conventional charging procedures, the following requirements shall be followed:
 - Ensure that contamination of different refrigerants does not occur when using charging equipment.
 - Hoses or lines shall be as short as possible to minimise the amount of refrigerant contained in them.
 - Cylinders shall be kept upright.
 - Ensure that the refrigeration system is earthed prior to charging the system with refrigerant.
 - Label the system when charging is complete (if not already).
 - Extreme care shall be taken not to overfill the refrigeration system.
 - Prior to recharging the system it shall be pressure tested with OFN.
- The system shall be leak tested on completion of charging but prior to commissioning.
- A follow up leak test shall be carried out prior to leaving the site.

14. Decommissioning

Before carrying out this procedure, it is essential that the technician is completely familiar with the equipment and all its detail.

It is recommended good practice that all refrigerants are recovered safely.

Safety precautions

WARNING

Prior to the task being carried out, an oil and refrigerant sample shall be taken in case analysis is required prior to re-use of reclaimed refrigerant. It is essential that electrical power is available before the task is commenced.

- a) Become familiar with the equipment and its operation.
- b) Isolate system electrically.
- c) Before attempting the procedure ensure that:
 - Mechanical handling equipment is available, if required, for handling refrigerant cylinders;
 - All personal protective equipment is available and being used correctly;
 - The recovery process is supervised at all times by a competent person;
 - Recovery equipment and cylinders conform to the appropriate standards.
- d) Pump down refrigerant system, if possible.
- e) If a vacuum is not possible, make a manifold so that refrigerant can be removed from various parts of the system.
- f) Make sure that cylinder is situated on the scales before recovery takes place.
- g) Start the recovery machine and operate in accordance with manufacturer's instructions.
- h) Do not overfill cylinders. (No more than 80 % volume liquid charge).
- i) Do not exceed the maximum working pressure of the cylinder, even temporarily.
- j) When the cylinders have been filled correctly and the process completed, make sure that the cylinders and the equipment are removed from site promptly and all isolation valves on the equipment are closed off.
- k) Recovered refrigerant shall not be charged into another refrigeration system unless it has been cleaned and checked.

15. Labelling

Equipment shall be labelled stating that it has been de-commissioned and emptied of refrigerant.

The label shall be dated and signed.

Ensure that there are labels on the equipment stating the equipment contains flammable refrigerant.

16. Recovery

- When removing refrigerant from a system, either for servicing or decommissioning, it is recommended good practice that all refrigerants are removed safely.
- When transferring refrigerant into cylinders, ensure that only appropriate refrigerant recovery cylinders are employed.
- Ensure that the correct number of cylinders for holding the total system charge is available.
- All cylinders to be used are designated for the recovered refrigerant and labelled for that refrigerant (i.e. special cylinders for the recovery of refrigerant).
- Cylinders shall be complete with pressure relief valve and associated shut-off valves in good working order.
- Empty recovery cylinders are evacuated and, if possible, cooled before recovery occurs.
- The recovery equipment shall be in good working order with a set of instructions concerning the equipment that is at hand and shall be suitable for the recovery of flammable refrigerants.
- In addition, a set of calibrated weighing scales shall be available and in good working order.
- Hoses shall be complete with leak-free disconnect couplings and in good condition.
- Before using the recovery machine, check that it is in satisfactory working order, has been properly maintained and that any associated electrical components are sealed to prevent ignition in the event of a refrigerant release.
- Consult manufacturer if in doubt.
- The recovered refrigerant shall be returned to the refrigerant supplier in the correct recovery cylinder, and the relevant Waste Transfer Note arranged.
- Do not mix refrigerants in recovery units and especially not in cylinders.
- If compressors or compressor oils are to be removed, ensure that they have been evacuated to an acceptable level to make certain that flammable refrigerant does not remain within the lubricant.
- The evacuation process shall be carried out prior to returning the compressor to the suppliers.
- Only electric heating to the compressor body shall be employed to accelerate this process.
- When oil is drained from a system, it shall be carried out safely.

WARNING

17. Competence of service personnel

Information and training

The training should include the substance of the following:

Information about the explosion potential of flammable refrigerants to show that flammables may be dangerous when handled without care.

Information about potential ignition sources, especially those that are not obvious, such as lighters, light switches, vacuum cleaners, electric heaters.

Information about the concept of sealed components and sealed enclosures according to IEC 60079-15:2010.

Information about the correct working procedures:

a) Commissioning

- Ensure that the floor area is sufficient for the refrigerant charge or that the ventilation duct is assembled in a correct manner.
- Connect the pipes and carry out a leak test before charging with refrigerant.
- Check safety equipment before putting into service.

b) Maintenance

- Portable equipment shall be repaired outside or in a workshop specially equipped for servicing units with flammable refrigerants.
- Ensure sufficient ventilation at the repair place.
- Be aware that malfunction of the equipment may be caused by refrigerant loss and a refrigerant leak is possible.
- Discharge capacitors in a way that won't cause any spark. The standard procedure to short circuit the capacitor terminals usually creates sparks.
- Reassemble sealed enclosures accurately. If seals are worn, replace them.
- Check safety equipment before putting into service.

c) Repair

- Portable equipment shall be repaired outside or in a workshop specially equipped for servicing units with flammable refrigerants.
- Ensure sufficient ventilation at the repair place.
- Be aware that of the equipment may be caused by refrigerant loss and a refrigerant leak is possible.
- Discharge capacitors in a way that won't cause any spark.
- When brazing is required the following procedures shall be carried out in the right order.
 - Remove the refrigerant. If the refrigerant is not required by national regulations, drain the refrigerant to the outside. Take care that the drained refrigerant will not cause any danger. In doubt, one person should guard the outlet. Take special care that drained refrigerant will not float back into the building.
 - Evacuate the refrigerant circuit.
 - Purge the refrigerant circuit with nitrogen for 5 min .
 - Evacuate again (not required for A2L refrigerants)
 - Remove parts to be replaced by cutting, not by flame.
 - Purge the braze point with nitrogen during the brazing procedure.
 - Carry out a leak test before charging with refrigerant.
- Reassemble sealed enclosures accurately. If seals are worn, replace them.
- Check safety equipment before putting into service.

d) Decommissioning

- If the safety is affected when the equipment is putted out of service. the refrigerant charge shall be removed before decommissioning.
- Ensure sufficient ventilation at the equipment location.
- Be aware that malfunction of the equipment may be caused by refrigerant loss and a leak is possible.
- Discharge capacitors in a way that won't cause any spark.
- Remove the If the recovery is not required by national regulations, drain the refrigerant to the outside. Take care that the drained refrigerant will not cause any danger. In doubt, one person should guard the outlet .Take special care that drained refrigerant will not float back into the building.

e) Disposal

- Ensure sufficient ventilation at the working place.
- Remove the refrigerant. If the recovery is not required by national regulations, drain the refrigerant to the outside. Take care that the drained refrigerant will not cause any danger. In doubt, one person should guard the outlet. Take special care that drained refrigerant will not float back into the building.
- Evacuate the refrigerant circuit
- Purge the refrigerant circuit with nitrogen for 5min.
- Evacuate again.
- Cut out the compressor and drain the oil.

Safety precautions





⚠ WARNING

- Appliance shall be installed, operated and stored in a room with a floor area larger than X (X see indoor unit instruction manual).
- The installation of pipe-work shall be kept to a a room with a floor area larger than X (X see indoor unit instruction manual).
- The pipe-work shall be complied with national gas regulations.
- The maximum refrigerant charge amount is X kg (X see below).
- When moving or relocating the air conditioner, consult experienced service technicians for disconnection and reinstallation of the unit.
- Do not place any other electrical products or household belongings under indoor unit or outdoor unit.
- Condensation dripping from the unit might get them wet, and may cause damage or malfunction of your property.
- Do not use means to accelerate the defrosting process or to clean, other than those recommended by the manufacturer.
- The appliance shall be stored in a room without continuously operating ignition sources (for example: open flames, an operating gas appliance or an operating electric heater).
- Do not pierce or burn.
- Be aware that refrigerants may not contain an odour.
- To keep ventilation openings clear of obstruction.
- The appliance shall be stored in a well-ventilated area where the room size corresponds to the room area as specified for operation.
- The appliance shall be stored in a room without continuously operating open flames (for example an operating gas appliance) and ignition sources (for example an operating electric heater).
- Any person who is involved with working on or breaking into a refrigerant circuit should hold a current valid certificate from an industry-accredited assessment authority, which authorises their competence to handle refrigerants safely in accordance with an industry recognised assessment specification.
- Servicing shall only be performed as recommended by the equipment manufacturer.
- Maintenance and repair requiring the assistance of other skilled personnel shall be carried out under the supervision of the person competent in the use of flammable refrigerants.
- The appliance shall be installed and stored so as to prevent mechanical damage from occurring.
- Mechanical connectors used indoors shall comply with ISO 14903. When mechanical connectors are reused indoors, sealing parts shall be renewed. When flared joints are reused indoors, the flare part shall be re-fabricated.
- The installation of pipe-work shall be kept to a minimum.
- Mechanical connections shall be accessible for maintenance purposes.

Max. Refrigerant Charge Amount X(kg)

Series	Up to 2 indoor units	Up to 3 indoor units	Up to 4 indoor units		Up to 5 indoor units
Model	18K	24K	27K	36K	42K
Max. Refrigerant charge (kg)	1.53	1.82	2.11	2.36	3.54

Explanation of symbols displayed on the indoor unit or outdoor unit.

	WARNING	This symbol shows that this appliance uses a flammable refrigerant. If the refrigerant is leaked and exposed to an external ignition source, there is a risk of fire.
	CAUTION	This symbol shows that the operation manual should be read carefully.
	CAUTION	This symbol shows that a service personnel should be handling this equipment with reference to the installation manual.
	CAUTION	This symbol shows that information is available such as the operating manual or installation manual.

Installation instructions

Installation diagram

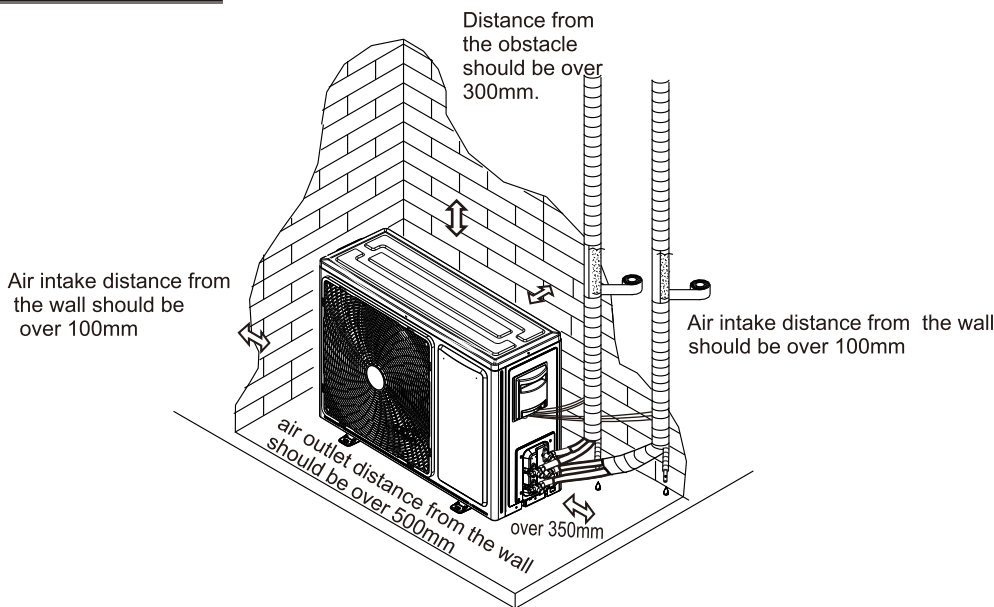

- Above figure is only a simple presentation of the unit, it may not match the external appearance of the unit you purchased.
- Installation must be performed in accordance with the national wiring standards by authorized personnel only.

Transportation and handling before installation

Transport the product as close to the installation location as practical before unpacking.

• Handling Method

When hanging the unit, ensure a balance of the unit, check safety and lift up smoothly.

- (1) Do not remove any packing materials.
- (2) Hang the unit under packing condition with two ropes, as shown in Fig below.

• Handling

If have no package to move, Please protect with cloth or paper.

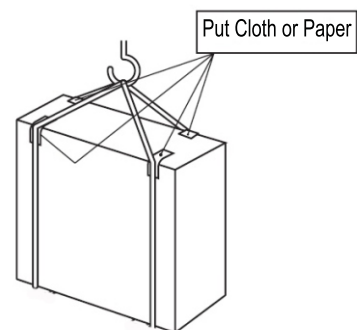
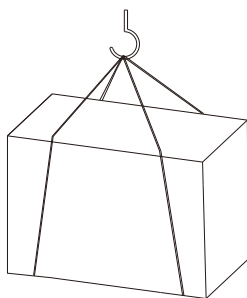

Installation locations selection

Before choosing the installation site, obtain user approval.

- Where it is not exposed to strong wind.
- Where airflow is good and clean.
- Where it is not exposed to rain and direct sunshine.
- Where neighbors are not annoyed by operation sound or hot air.
- Where rigid wall or support is available to prevent the increase of operation sound or vibration.
- Where there is no risk of combustible gas leakage.
- Where it is at least 3m away from the antenna of TV set or radio. An amplifier may be required for the affected device.
- Install the unit horizontally.
- Please install it in an area not affected by snowfall or blowing snow. In areas with heavy snow, please install a canopy, a pedestal and/or some baffle boards.

Installation instructions

⚠ CAUTION:

Avoid the following places for installation where air conditioner trouble is liable to occur.

- Where there is much machine oil.
- Salty places such as seaside.
- Where sulfide gas is generated such as a hot spring.
- Where there is high-frequency or wireless equipment.

NOTE:

When operating the air conditioner in low outside temperature, be sure to follow the instruction describe below.

- Never install the outdoor unit in a place where its air inlet/outlet side may be exposed directly to wind.
- To prevent exposure to wind, install the outdoor unit with its air inlet side facing the wall.
- To prevent exposure to wind, it is recommended to install a baffle board on the air outlet side of the outdoor unit.

Drainage elbow and drain hose installation

Install Drainage Elbow and Drain Hose

- The condensate water may drains from the outdoor unit when the unit operates in heating mode. In order to avoid disturbing neighbors also to protect the environment, it is necessary to install a drainage elbow and a drain hose to drain out the condensate water.
- Please do the drainage work before the indoor unit and outdoor unit are connected. Otherwise, it will be difficult to install drainage elbow after the machine becomes immovable.)
- Connect the drain hose (field-supplied, inside diameter: 15mm) as shown in the figure for drainage.

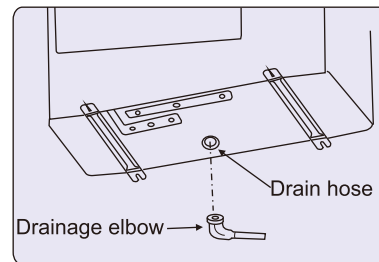

NOTE:

Do not use the drain elbow in the cold region. Drain may freeze to stop the fan runs.

Outdoor unit installation

⚠ NOTE:

- Be sure to fix the legs of the units with bolts when installing it.
- Be sure to install the unit firmly to ensure that it does not fall by earthquake or gust.
- The anchor bolts, nuts and washers for the installation are user prepared.

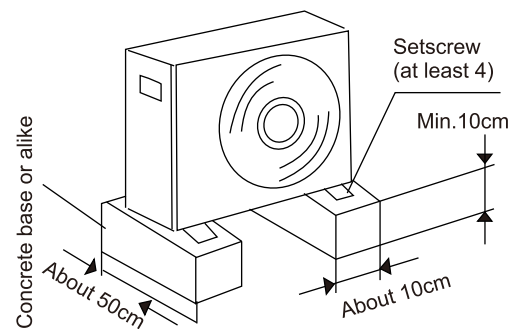
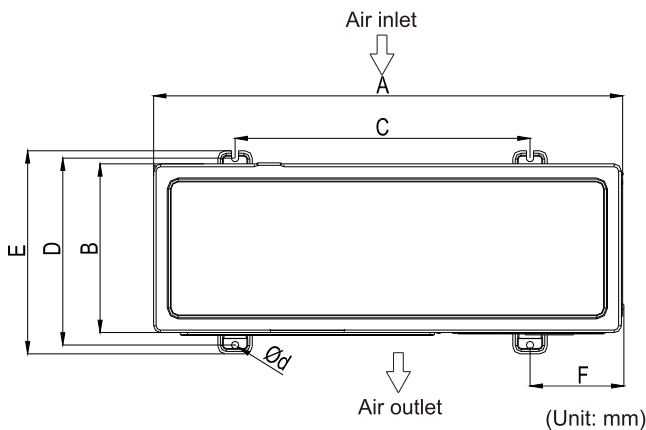

Series	Model (Btu/h)	A	B	C	D	E	F	d
Up to 2 indoor units	18K	860	310	542	341	368	168	11×17
Up to 3 indoor units	24K	860	310	542	341	368	168	11×17
Up to 4 indoor units	27K	860	310	542	341	368	168	11×17
	36K	950	340	580	380	414	185	15
Up to 5 indoor units	42K	950	340	580	380	414	185	15

Installation instructions

Refrigerant piping

1. Piping requirement

Outer Diameter of Pipe	Gas(mm)	φ 9.52
	Liquid(mm)	φ 6.35

The maximum allowable length of refrigerant piping, and the maximum allowable height difference between the outdoor and indoor units, are listed below. The shorter the refrigerant piping is, the better the performance will be. So the connecting pipe should be as short as possible.

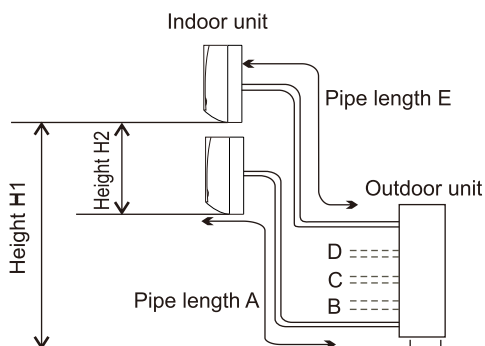

Item	Model	Up to 2 indoor units	Up to 3 indoor units	Up to 4 indoor units	Up to 5 indoor units
		18K	24K	27K/36K	27K/36K
Piping to each indoor unit (A/B/C/D/E)	m	≤20	≤25	≤25	≤25
Total length of piping between all units	m	A+B≤30	A+B+C≤50	A+B+C+D≤60	A+B+C+D≤80
Max Height Between Indoor Unit and Outdoor Unit (H1)	m	≤15			
Max Height Between Indoor Units (H2)	m	≤7.5			

Additional refrigerant charge

The unit has been filled with refrigerant, but if L (total pipe length) exceeds standard length, additional charge with refrigerant (R32) is necessary.

For up to 2 indoor units type:

$$\text{Additional refrigerant charge} = (L-15) \times 12\text{g/m}$$

For up to 3 indoor units type:

$$\text{Additional refrigerant charge} = (L-20) \times 12\text{g/m}$$

For up to 4 indoor units type:

$$\text{Additional refrigerant charge} = (L-30) \times 12\text{g/m}$$

For up to 5 indoor units type:

$$\text{Additional refrigerant charge} = (L-35) \times 12\text{g/m}$$

2. Piping material

- Prepare the copper pipe on the spot.
- Choose dustless, non-humid, clean copper pipe. Before installing the pipe, use nitrogen or dry air to blow away the dust and impurity on the tube.
- Piping thickness shows as below.

Diameter (mm)	Thickness (mm)
φ 6.35	0.8
φ 9.52	0.8
φ 12.7	0.8
φ 15.88	1.0

CAUTION

<p>When installing pipe through the wall, secure a cap at the end of the pipe.</p> <div style="display: flex; justify-content: space-around;"> <div style="text-align: center;"> <p>Correct</p> </div> <div style="text-align: center;"> <p>Incorrect</p> </div> </div> <p style="text-align: center;">Attach a cap or vinyl tape.</p>	<p>Do not place the pipe directly on the ground.</p> <div style="display: flex; justify-content: space-around;"> <div style="text-align: center;"> <p>Correct</p> </div> <div style="text-align: center;"> <p>Incorrect</p> </div> </div> <p style="text-align: center;">Protected with the tape or plug.</p>	<div style="display: flex; justify-content: space-around;"> <div style="text-align: center;"> <p>Correct</p> </div> <div style="text-align: center;"> <p>Incorrect</p> </div> </div> <p style="text-align: center;">Rain water can enter.</p> <p style="text-align: center;">Attach a cap or vinyl bag with rubber band.</p>
--	---	--

Installation instructions

3. Processing of refrigerant piping

(1) Pipe cutting

- Cut the copper pipe correctly with pipe cutter.

(2) Burrs removal

- Completely remove all burrs from the cut cross section of the pipe.
- Put the end of the copper pipe downward to prevent burrs from dropping in the pipe.

(3) Putting nut on

- Remove flare nuts attached to indoor and outdoor units, then put them on pipe having completed burr removal. (Not possible to put them on after flaring work).
- Flare nut for pipe depending on the diameter of pipe.

(4) Flaring work

- Perform flaring work using flaring tool as shown below.

(5) Check

- Compare the flared work with the figure below.
- If flare is noted to be defective, cut off the flared section and perform flaring work again.

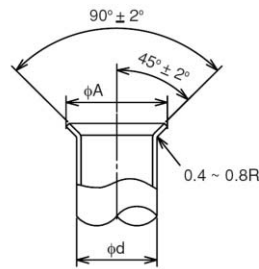

(Unit: mm)

Diameter Φd	A ⁺⁰ _{-0.4}
6.35	9.1
9.52	13.2
12.7	16.6
15.88	19.7

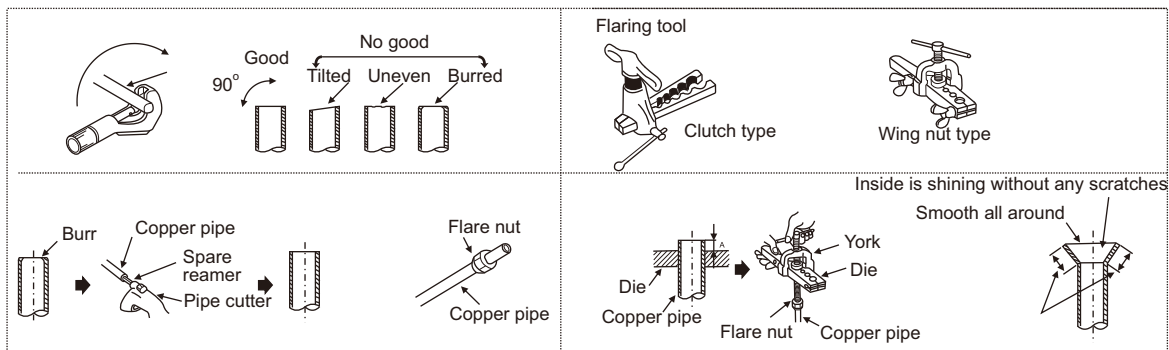

4. Piping Connection

(1) Confirm that the valve is closed.

- ### (2) Connect the indoor unit and the outdoor unit with field-supplied refrigerant piping. Suspend the refrigerant piping at certain points and prevent the refrigerant piping from touching the weak part of the building such as wall, ceiling, etc. (If touched, abnormal sound may occur due to the vibration of the piping. Pay special attention in case of short piping length.)



Double Spanner work

(3) Tightening the flare nut use two spanners like figure right.

- ### (4) Apply the refrigerant oil (field-supply) thinly at the seat surface of the flare nut and pipe before connecting and tightening.

- ### (5) Outdoor refrigerant piping should be connected with stop valves.

- ### (6) After finishing connecting the refrigerant pipes, keep it warm with the insulation material like figure right after air-tight test.

- For outdoor unit side, surely insulate every piping including valves.
- Cover piping joints with pipe cover.
- Using piping tape, apply taping starting from the entry of outdoor unit. Fix the end of piping tape with adhesive tape.
- Fix the end of piping tape with adhesive tape.
- When piping has to be arranged through above ceiling, closet or area where temperature and humidity are high, wind additional commercially sold insulation for prevention of condensation.

Pipe Size	Torque
Φ6.35(1/4)	20N · m (2kgf · m)
Φ9.52(3/8)	40N · m (4kgf · m)
Φ12.7(1/2)	60N · m (6kgf · m)
Φ15.88(5/8)	80N · m (8kgf · m)

Tightening Torque for Flare Nut

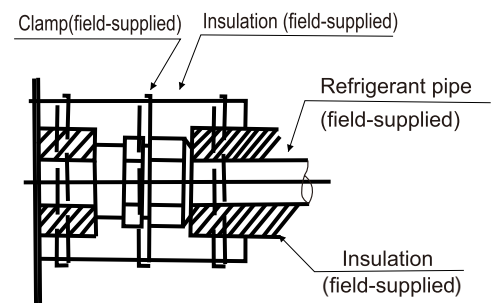

Piping insulation procedure

Installation instructions



CAUTION

If the diameter of connection pipe does not match the port size of outdoor unit, select proper different-diameter joints in the accessory according to the following table.

Figure	Purpose
	Change pipe diameter from 3/8 inch (9.52mm) to 1/2 inch (12.7mm)

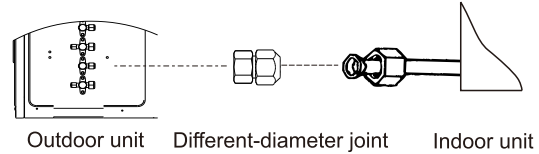

Connect pipes using different-diameter joint

5. Air Tight Test

Do use Nitrogen.

Connect the gauge manifold using charging hoses with a nitrogen cylinder to check joints of the liquid line and the gas line stop valves.

Perform the air-tight test.

Don't open the gas line stop valves.

Apply nitrogen gas pressure of 4.15MPa.

Check any gas leakage at the flare nut connections, or brazed parts by gas leak detector or foaming agent.

Gas pressure doesn't decrease is OK.

After the air tight test, release nitrogen gas.

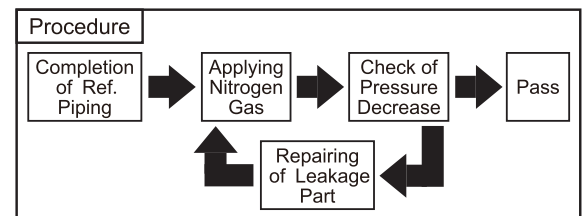

Air tight procedure

6. Vacuum pumping and charge refrigerant

• Vacuum Pumping

- (1) Remove the service port cap of the stop valve on the gas pipe side of the outdoor unit.
- (2) Connect the manifold gauge and vacuum pump to the service port of the stop valve on the gas pipe side of the outdoor unit.
- (3) Run the vacuum pump. (Work for more than 15 minutes)
- (4) Check the vacuum with the gauge manifold valve, then close the gauge manifold valve and stop the vacuum pump.
- (5) Leave it as is for one or two minutes. Make sure the pointer of the manifold gauge remains in the same position. Confirm that the pressure gauge shows -0.101MPa (or -760mmHg).
- (6) Remove the manifold gauge quickly from the service port of the stop valve.
- (7) After refrigerant pipes are connected and evacuated, fully open all stop valves on both sides of gas pipe and liquid pipe.
- (8) Open adjusted valve to add refrigerant (must be refrigerant is liquid).
- (9) Tighten the cap to the service port.
- (10) Retighten the cap.
- (11) Leak test foam with halogen leak detector to check the flare nut and brazing Carolina Department leaks. Use foam that not generates ammonia (NH₃) in the reaction.

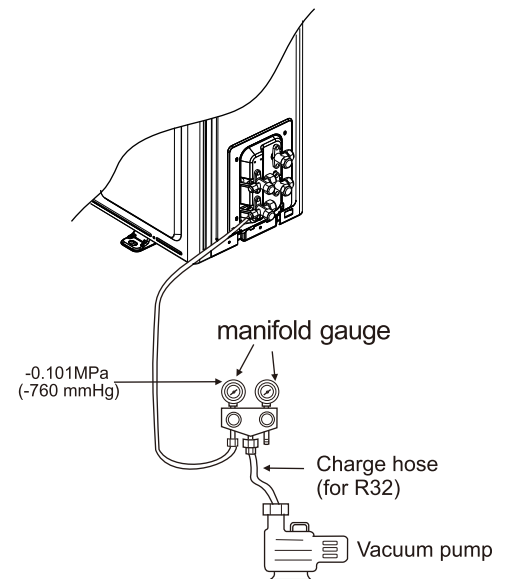

CAUTION

- (1) Each pipelines needs to be evacuated individually.
- (2) An excess or a shortage of refrigerant is the main cause of trouble to the unit. Charge the correct refrigerant quantity according to the description of label at the inside of the manual.
- (3) Check refrigerant leakage in detail. If a large refrigerant leakage occurs, it will cause difficulty with breathing or harmful gases will occur if a fire is being used in the room.

Installation instructions

•Additional refrigerant charge

The unit has been filled with refrigerant.

Please according "Piping Requirement" to calculate additional charge.

After vacuum pump procedure has been finished, first exhaust air from charge hose, then open valves, charge refrigerant as "liquid" type through Liquid stop valve.

At the end, please close valves and record the refrigerant charging quantity.

Wiring



WARNING

- Turn OFF the main power switch to the indoor unit and the outdoor unit and wait for more than 3 minutes before electrical wiring work or a periodical check is performed.
- Check to ensure that the indoor fan and the outdoor fan have stopped before electrical wiring work or a periodical check is performed.
- Protect the wires, electrical parts, etc. from rats or other small animals. If not protected, rats may gnaw at unprotected parts and at the worst, a fire will occur.
- Avoid the wiring from touching the refrigerant pipes, plate edges and electrical parts inside the unit.
- If not do, the wires will be damaged and at the worst, a fire will occur.
- Install an ELB (Electric Leakage Break) in the power source.
- If ELB is not used, it will cause electric shock or fire at the worst.
- This unit uses an inverter, which means that it must be used an earth leak detector capable handing harmonics in order to prevent malfunctioning of the earth leak detector itself.
- Do not use intermediate connection wires, stranded wires(see <Attentions when Connect the power supply wiring>), extension cables or control line connection, because the use of these wires may cause fever, electric shock or fire.
- The tightening torque of each screw shall be as follows.
 - M4: 1.0 to 1.3 N·m
 - M5: 2.0 to 2.5 N·m
 - M6: 4.0 to 5.0 N·m
 - M8: 9.0 to 11.0 N·m
 - M10: 18.0 to 23.0 N·mKeep the above tightening torque when wiring work.



CAUTION

- With tape material along the wire wrapped, sealed wiring holes, prevent the condensed water and insects.
- Tightly secure the power source wiring using the cord clamp inside the unit.

NOTE: Fix the rubber bushes with adhesive when conduit tubes to the outdoor unit are not used.

General Check

- (1) Make sure that the field-selected electrical components (main power switches, circuit breakers, wires, conduit connectors and wire terminals) have been properly selected according to the electrical data.
Make sure that the components comply with National Electrical Code (NEC).
- (2) Check to ensure that the voltage of power supply is within +10% of nominal voltage and earth phase is contained in the power supply wires. If not, electrical parts will be damaged.
- (3) Check to ensure that the capacity of power supply is enough.
If not, the compressor will not be able to operate cause of voltage drop abnormally at starting.
- (4) Check to ensure that the earth wire is connected.
- (5) Install a main switch, multi-pole main switch with a space of 3.5mm or more, single phase main switch with a space of 3.0mm or more between each phase. Please use the special three-phase power switch for 3-Phase product.
- (6) Check to ensure that the electrical resistance is more than 2MΩ, by measuring the resistance between ground and the terminal of the electrical parts. If not, do not operate the system until the electrical leakage is found and repaired.

Installation instructions

Electrical wiring diagram

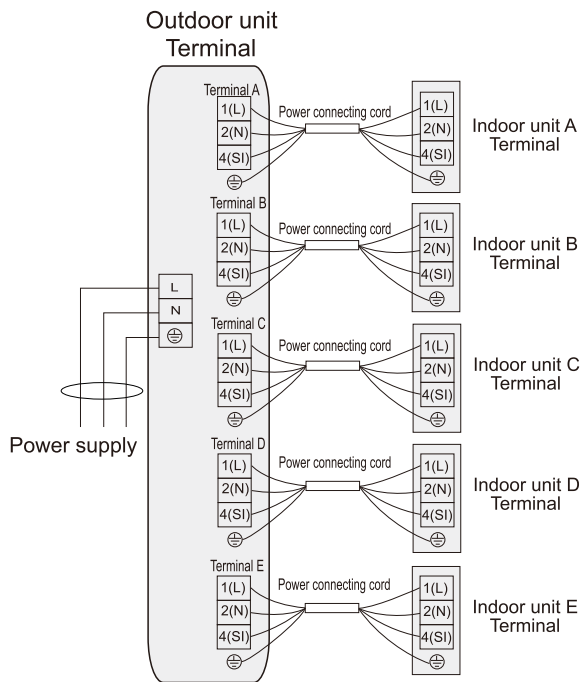

NOTE:
For some indoor units

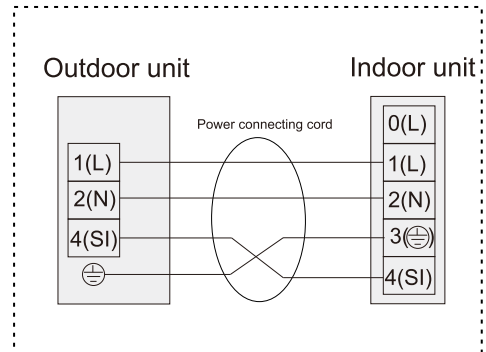

NOTES:

1. For series up to 2 indoor units, there is no INDOOR UNIT C, D and E.
2. For series up to 3 indoor units, there is no INDOOR UNIT D and E.
3. For series up to 4 indoor units, there is no INDOOR UNIT E.

Wires connect steps:

Take 24K model for example

- (1) Unscrew the screws on terminal cover parts, and remove it as shown by the arrow mark.
- (2) Connect the power supply cable and the connection cable to terminal.
- (3) Fasten the power supply cable and the connection cable with the cable clamp.
- (4) Put the terminal cover parts back after completion of the work.

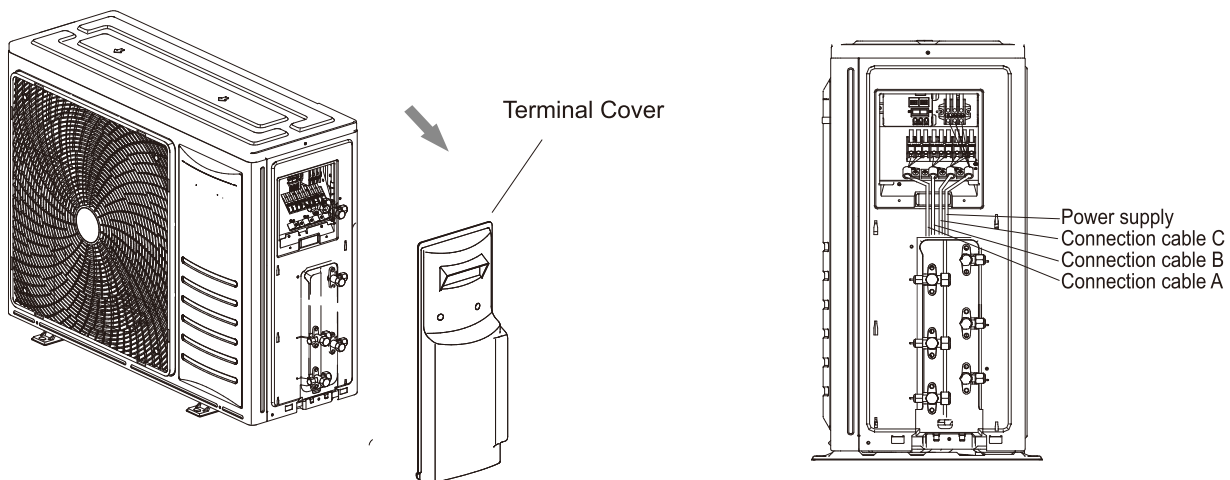

Installation instructions

Electrical Data

Series	Model Capacity	Power Supply	ELB		Power Source Cable Size	Transmitting Cable Size	Circuit Breaker(A)
			Nominal Current (A)	Nominal Sensitive Current (mA)	IEC 60335-1	IEC 60335-1	
up to 2 indoor units	18K	220-240V ~, 50Hz	20	30	3×1.5mm ²	4×1.5mm ²	20
up to 3 indoor units	24K	220-240V ~, 50Hz	32	30	3×2.5mm ²	4×1.5mm ²	32
up to 4 indoor units	27K/36K	220-240V ~, 50Hz	32	30	3×2.5mm ²	4×1.5mm ²	32
up to 5 indoor units	42K	220-240V ~, 50Hz	50	30	3×6.0mm ²	4×1.5mm ²	50

Max. Running Current (A): REFER TO NAMEPLATE

NOTE:

- Follow local codes and regulations when select field wires, and all the above are the minimum wire size.
- Use the wires which are not lighter than the ordinary polychloroprene sheathed flexible cord.(Cord designation H07RN-F).
- The wire sizes in the above table are selected at the maximum current of the unit according to the European Standard, IEC60335-1.
- Install main switch and ELB for each system separately. Select the high response type ELB that is acted within 0.1second.
In the case that power cables are connected in series, add each unit maximum current and select wires below.

Selection According to IEC60335-1

Current I (A)	Wire Size (mm ²)
$i \leq 6$	0.75
$6 < i \leq 10$	1
$10 < i \leq 16$	1.5
$16 < i \leq 25$	2.5
$25 < i \leq 32$	4
$32 < i \leq 40$	6
$40 < i \leq 63$	10
$63 < i$	*

*: in the case that current exceeds 63A, do not connect cables in series.

<Attentions when Connect the power supply wiring>

1. When connecting the terminal block using stranded wire, make sure to use the round crimp-style terminal for connection to the power supply terminal block. Place the round crimp-style terminals on the wires up to the covered part and secure in place.

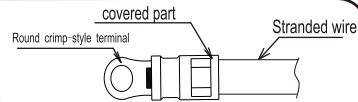

2. When connecting the terminal block using a single core wire, be sure to perform curing.

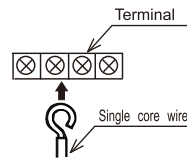

DRED (Demand Respond Enable System) Connector

A demand communication cable is supplied with outdoor unit.

It can be connect to DRED for limit setting of power consumption if need.

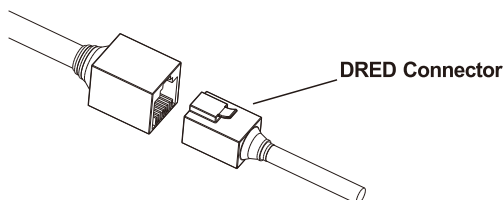

Installation instructions

Trial Run

Trial run should be performed after refrigerant piping, drain, wiring, etc. have been finished.



The air-conditioner is provided with a crankcase heater, check to ensure that the switch on the main power source has been ON for more than 6 hours ahead of power on preheating, otherwise it might damage the compressor!

Do not operate the system until all the check points have been cleared.

(A) Check to ensure that the stop valves of the outdoor unit are fully opened.

(B) Check to ensure the electric wires has been fully connected.

(C) Check to ensure that the electrical resistance is more than 2 MΩ, by measuring the resistance between ground and the terminal of the electrical parts. If not, do not operate the system until the electrical leakage is found and repaired.

Trial run function identification

Turn ON the appliance to proceed trial run.

Pay attention to the following items while the system is running.

Do not touch any of the parts by hand at the discharge gas side, since the compressor chamber and the pipes at the discharge side are heated higher than 90°C.

Test if the appliance can run well.

- Turn off the power after trial run is finished.

Installation of the appliance is generally finished after the above operations are done. If you still have any trouble, please contact local technical service center of our company for further information.

