

Amana

Bottom Freezer Refrigerator Owner's Manual

| | |
|-----------------------------|----|
| English | 2 |
| Français | 18 |
| Sección en castellano | 35 |

Keep these instructions for future reference. Be sure this manual stays with refrigerator.

Contents

- Contents 2
- Electrical Requirements 2
- Model Identification 3
- Proper Disposal of your Refrigerator 3
- Cutout Dimensions 4
- Installation Instructions 4
- Installation Checklist 7
- Controls 8
 - Fresh Food and Deepfreeze® Controls 8
 - Setting Controls 8
- Fresh Food Features 8
 - Spillsaver™ Shelves 8
 - Deli Port™ 9
 - Drawers 9
 - Crisper Tote™ 9
 - Covered Storage Bucket 10
 - Dairy Centers 10
 - Door Buckets 10
 - Door Shelf 10
 - Adjustable Dividers 11
 - Tall Package Retainer 11
- Deepfreeze® Features 11
 - Slide and Serve™ Ice 11
 - Deepfreeze® Shelf 12
 - Wire Basket 12
 - Wire Divider 12
 - Pivot Bin™ 12
- Care and Cleaning 12
 - General 12
 - Odor Removal 12
 - Adhesives 13
 - Door Gaskets 13
 - Condenser Coils 13
 - Glass Shelves 13
 - Light Bulbs 13
- Energy Tips 14
- Vacation Tips 14
- Normal Operating Sounds 14
- Before Calling For Service 15
- Factory Service Centers 16
- Asure™ Service Plan 16
- Warranty 17

Electrical Requirements

 **Recognize this symbol as a safety precaution.**

 **WARNING**

Electrical Grounding Instructions — This refrigerator is equipped with a three-prong (grounding) plug for protection against possible shock hazards. If a two-prong wall receptacle is encountered, contact a qualified electrician and have the two-prong wall receptacle replaced with a properly grounded three-prong wall receptacle in accordance with the National Electrical Code.

Refrigerator is designed to operate on a separate 103 to 126 volt, 15 amp., 60 cycle line.

Do not under any circumstances cut or remove the round grounding prong from the plug. Refrigerator must be grounded at all times. Do not remove warning tag from power cord.

 **WARNING**

Do not use a two-prong adapter. Do not use an extension cord.



Model Identification

Thank you for purchasing this Amana® refrigerator. Please read this Owner's Manual thoroughly. This manual provides proper maintenance information. Any questions, call the Consumer Affairs Department at **1-800-843-0304** inside U.S.A. and **1-319-622-5511** outside U.S.A.

Complete registration card and promptly return. If registration card is missing, call the Consumer Affairs Department.

When contacting Amana , provide product information. Product information is on the serial plate, located on ceiling of Fresh Food section. Record the following information:

Model Number: _____
Manufacturing Number: _____
S/N or Serial Number: _____
Date of purchase: _____
Dealer's name and address: _____

Keep a copy of sales receipt for future reference.

Amana also has a network of independent authorized technicians. Locate a Factory Service Center or independent authorized technician by calling **1-800-628-5782** inside U.S.A. and **1-319-622-5511** outside U.S.A. Warranty service must be performed by an **authorized** Amana technician. Amana also recommends contacting an **authorized** Amana technician if service is required after warranty expires.

Amana offers a complete line of appliances: cooktops, dishwashers, dryers, freezers, microwave ovens, ranges, wall ovens, and washers. Amana also manufactures a complete selection of high efficiency gas furnaces plus both central and room air conditioners.

Enjoy this new Amana refrigerator.

Proper Disposal of your Refrigerator

IMPORTANT: Child entrapment and suffocation are not problems of the past. Junked or abandoned refrigerators are still dangerous—even if they sit for "just a few days". If you are getting rid of your old refrigerator, please follow the instructions below to help prevent accidents.

BEFORE YOU THROW AWAY YOUR OLD REFRIGERATOR OR FREEZER:

- Take off the doors.
- Leave the shelves in place so children may not easily climb inside.

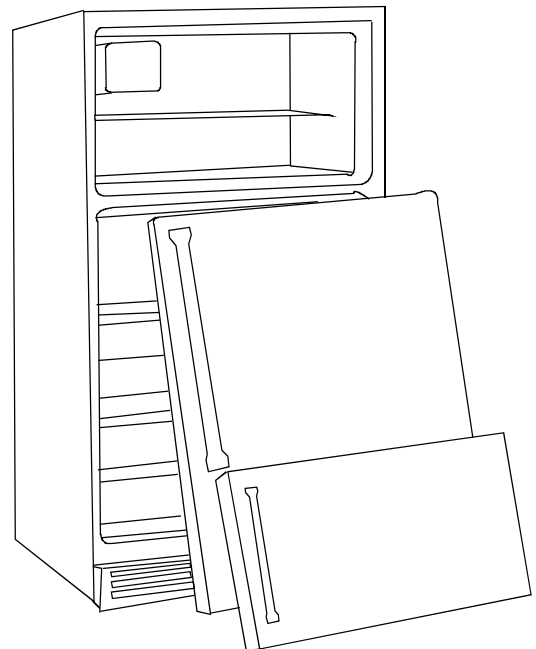

Cutout Dimensions

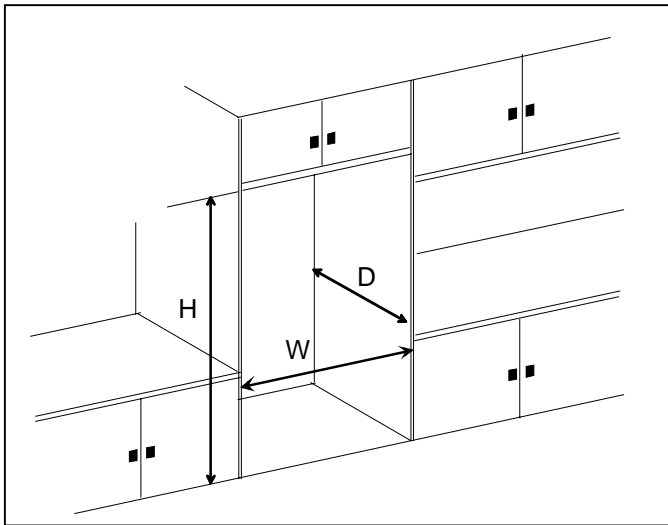

| | Single Installation | Double Installation |
|---|--|---------------------|
| H | 69" with 12" deep cabinets above refrigerator 70" with 24" deep cabinets above refrigerator | |
| W | 36" | 72¾" * |
| D | 24" | 24" |

* See BID trim kit for specifications

Installation Instructions

Proper installation will ensure that this refrigerator operates most efficiently. Amana cannot be responsible for improper installation.

1. Remove doors if necessary.

- Remove top hinge cover. Remove top hinge.
- Remove Fresh Food door.
- Lift door closure off center hinge pin. Remove center hinge pin.
- Remove Deepfreeze® door. An internal support rod may slide out. Replace rod before hanging door.
- Remove center hinge.
- Remove toe grille. Remove bottom hinge.

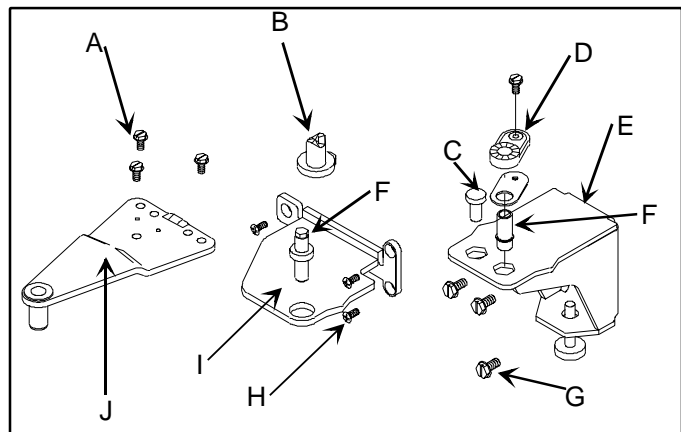

- | | |
|------------------------|--------------------|
| A. 5/16" (8 mm) screws | B. Door closure |
| C. Plug | D. Door closure |
| E. Bottom hinge | F. Pin |
| G. 3/8" (9 mm) screws | H. Phillips screws |
| I. Center hinge | J. Top hinge |

Caution

To avoid property damage, protect soft vinyl or other flooring with cardboard, rugs, or other protective material when moving refrigerator.

- Slide appliance cart under side of refrigerator. Wrap refrigerator with blanket or pad. Thread cart strap around refrigerator and tighten. Do not overtighten strap. Move refrigerator in front of final location.

h. Reverse doors if necessary.

BRF20 model

- Nameplate logo will automatically reverse.
- Replace internal support rod in hinge side of Deepfreeze® door prior to hanging door.

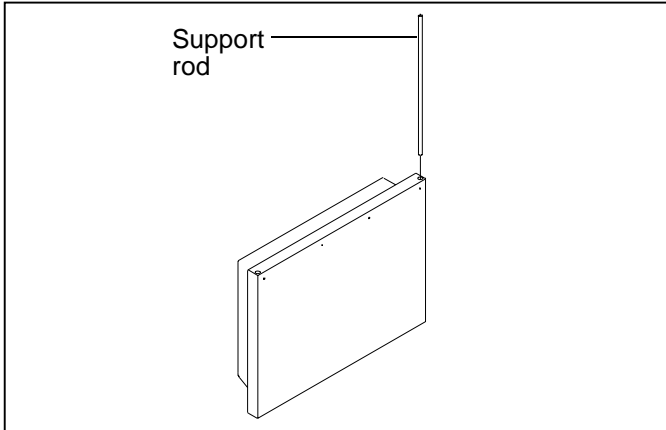

- Move bottom hinge pin and door closure from right bottom hinge to left bottom hinge. Move plastic plug from left bottom hinge to right bottom hinge using a needle nose pliers. Pinch tabs from underside of hinge to remove.

BBI20 model

- Do not install the 2 supplied trim pieces until doors have been reversed.
- Kit, #TK231L, is required to reverse doors. Specify color when ordering:
TK231LW is white
TK231LL is almond
TK231LE is ebony
TK231LS is stainless

i. Rehang doors by reversing steps a-f.

- Use a penny at top to space door $\frac{3}{4}$ " (18 mm) from cabinet.
- Handle side of door should be approximately $\frac{1}{8}$ " (3 mm) higher than hinge side.

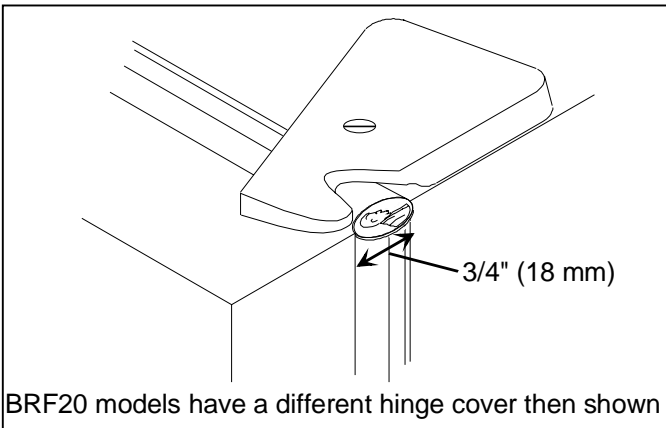

2. Connect ice maker water supply line.

- See instructions on rear of refrigerator cabinet.

3. Plug in power cord.

4. Move refrigerator into final location.

5. Level refrigerator.

- Remove toe grille.
- Turn roller adjustment screw to raise or lower rear of refrigerator.
- Turn stabilizing legs clockwise to raise or counterclockwise to lower front of refrigerator. Stabilizing legs must be firmly against floor.

Caution

To avoid personal injury or property damage caused by refrigerator tipping, stabilizing legs must be firmly against floor.

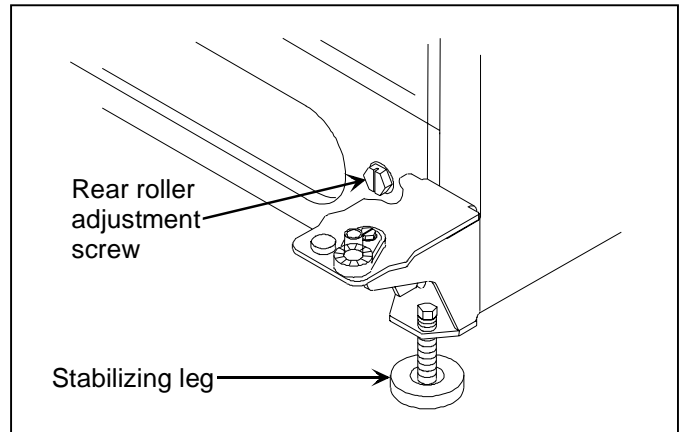

6. Install Decorator Panels

(BBI20 Models)

If raised panels are used, must allow 2 1/2" minimum of clearance between raised edge of panel and refrigerator handle.

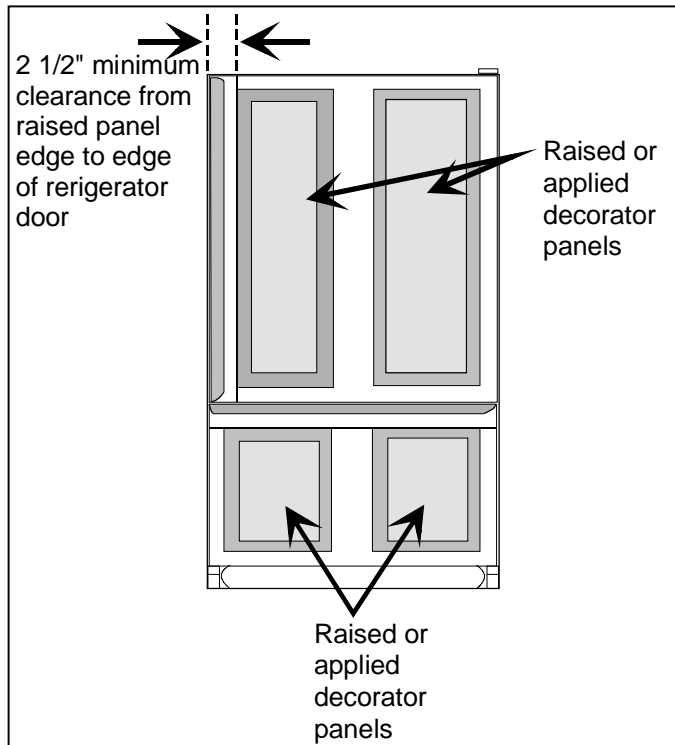

Listed below are required height x width dimensions for decorator panels. Panels are not supplied with the refrigerator and can be purchased locally or as optional kits from an Amana dealer.



Caution

To avoid personal injury or property damage, Fresh Food panel should not weigh more than 30 lbs (14 kgs) and Deepfreeze® panel should not weigh more than 15 lbs (7 kgs).

| | |
|------------------|--------------------------------------|
| Fresh Food Door | 41" x 35 1/8" 104 mm x 89 mm |
| Deepfreeze® Door | 21 15/16" x 35 5/8" 56 mm x 90 mm |

- Remove refrigerator door handle. Slide panel in place on refrigerator door. Replace door handle and install left side trim.
- Slide panel in place on freezer door. Install right side trim.

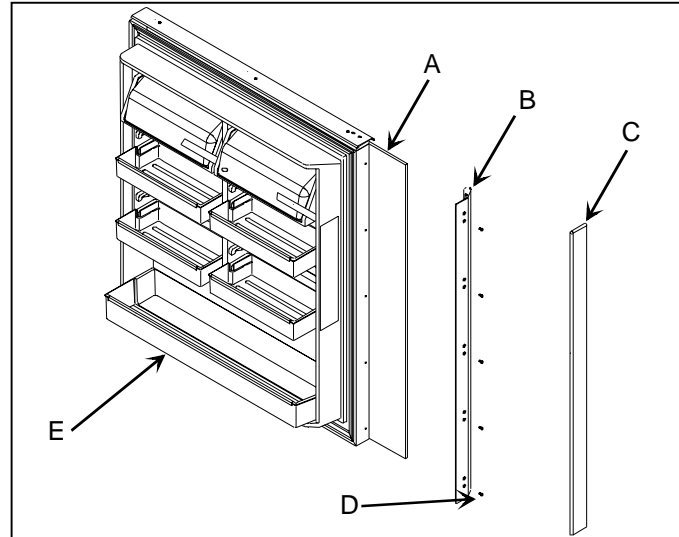

- A. Decorator door panel B. Door handle
C. Door handle trim D. Phillips screws
E. Refrigerator door

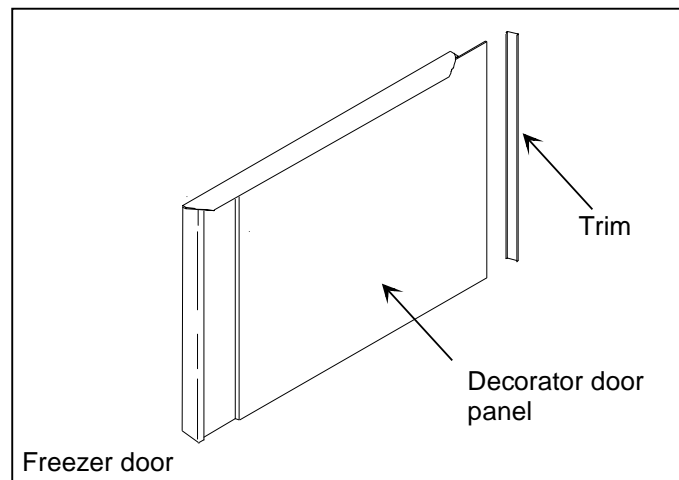

7. Review "Installation Checklist".

Installation Checklist

This checklist is for personal records only.

| Consumer | Installer | |
|----------|-----------|--|
|----------|-----------|--|

| | | |
|--------------------------|--------------------------|--|
| <input type="checkbox"/> | <input type="checkbox"/> | |
|--------------------------|--------------------------|--|

Doors

Handles are solidly attached to doors.

| | | |
|--------------------------|--------------------------|--|
| <input type="checkbox"/> | <input type="checkbox"/> | |
|--------------------------|--------------------------|--|

Handle side of door is 1/8" (3 mm) higher than hinge side of door. (Door lowers when loaded with food.)

| | | |
|--------------------------|--------------------------|--|
| <input type="checkbox"/> | <input type="checkbox"/> | |
|--------------------------|--------------------------|--|

Doors seal completely to refrigerator cabinet.

Leveling

Refrigerator is tilted 1/4" (6 mm) from front to rear.

| | | |
|--------------------------|--------------------------|--|
| <input type="checkbox"/> | <input type="checkbox"/> | |
|--------------------------|--------------------------|--|

Stabilizing legs are against floor.

| | | |
|--------------------------|--------------------------|--|
| <input type="checkbox"/> | <input type="checkbox"/> | |
|--------------------------|--------------------------|--|

Toe grille is properly attached to refrigerator.

| | | |
|--------------------------|--------------------------|--|
| <input type="checkbox"/> | <input type="checkbox"/> | |
|--------------------------|--------------------------|--|

Ice Maker (some models)

Water supply to refrigerator is turned on.

| | | |
|--------------------------|--------------------------|--|
| <input type="checkbox"/> | <input type="checkbox"/> | |
|--------------------------|--------------------------|--|

Water leaks are not present at connection between household water supply and refrigerator. (After 24 hours, consumer should check connection for water leaks.)

| | | |
|--------------------------|--------------------------|--|
| <input type="checkbox"/> | <input type="checkbox"/> | |
|--------------------------|--------------------------|--|

Ice maker arm is down for ice production. (It may take up to 24 hours for first harvest of ice.)

| | | |
|--------------------------|--------------------------|--|
| <input type="checkbox"/> | <input type="checkbox"/> | |
|--------------------------|--------------------------|--|

Product Literature

Owner's manual is reviewed including the following information:

- product registration card
- Fresh Food and Deepfreeze® controls
- humidity controlled crisper drawer
- temperature controlled drawer
- normal operating sounds

| | | |
|--------------------------|--------------------------|--|
| <input type="checkbox"/> | <input type="checkbox"/> | |
|--------------------------|--------------------------|--|

Notes _____

| | | | |
|----------------------|-----------------------|---------------------------------------|------|
| Consumer's Signature | Installer's Signature | Installer's Company Name/Phone Number | Date |
|----------------------|-----------------------|---------------------------------------|------|



Controls

This refrigerator operates most efficiently in normal household temperatures of 55° to 110°F (13°C to 43°C).

Fresh Food and Deepfreeze® Controls

Fresh Food control is located on upper rear wall of Fresh Food section.

Deepfreeze® control is located on right front ceiling of Deepfreeze® section.

When Deepfreeze® control is set to *OFF*, neither Fresh Food nor Deepfreeze® sections will cool. Initially, set both controls to 4. Wait 24 hours for Fresh Food and Deepfreeze® sections to reach desired temperatures. After 24 hours, adjust controls, one number at a time, as desired. 1 is warmest setting and 7 is coldest.

Setting Controls

Set controls precisely using a household thermometer that includes temperatures between -5° to 50°F (-21° to 10°C).

Put thermometer snugly between frozen packages in Deepfreeze® section. Wait 5-8 hours. If Deepfreeze® temperature is not 0° to 2°F (-17° to -16°C), adjust control, one number at a time. Check again after 5-8 hours.

Put thermometer in a glass of water in middle of Fresh Food section. Wait 5-8 hours. If Fresh Food temperature is not 38° to 40°F (3° to 4°C), adjust control, one number at a time. Check again after 5-8 hours.

Fresh Food Features



Caution

To avoid property damage, confirm shelf is secure before placing items on shelf.

Spillsaver™ Shelves

Spillsaver™ shelves adjust to meet individual storage needs and hold simple spills for easier cleaning.



Caution

To avoid personal injury or property damage, handle tempered glass shelves carefully. Shelves may break suddenly if nicked, scratched, or exposed to sudden temperature change.

- Remove shelves by lifting front, releasing hooks from metal track then pulling out.
- Replace shelves by inserting hooks into metal track and lowering front.

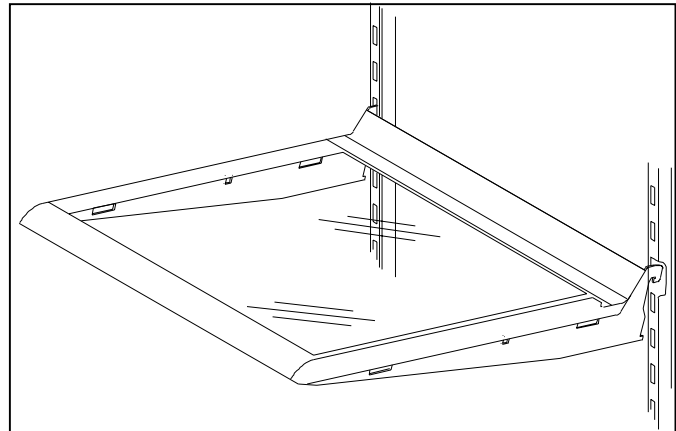

EasyGlide™ shelves pull forward for easy access of items in back.

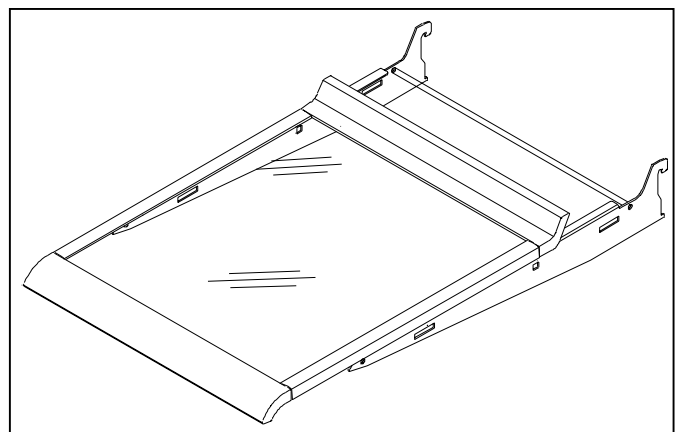

Deli Port™

Deli Port™ provides space saving storage underneath Spillsaver™ shelf and pulls forward for easy access.

- Remove shelf by pulling forward until shelf stops. Push tabs on sides of shelf in and pull shelf forward.
- Replace shelf by inserting shelf into track and sliding back.

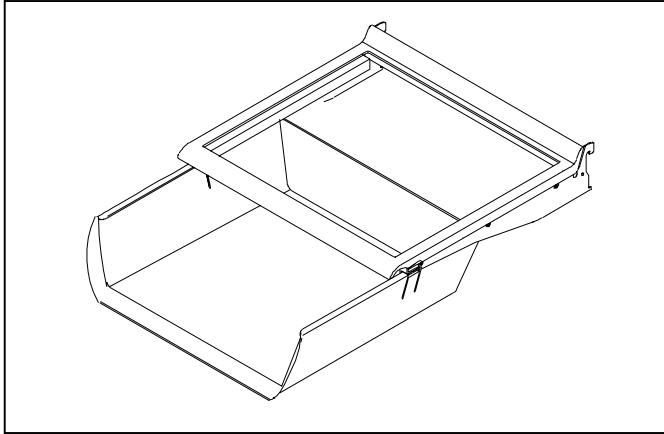

Drawers

Humidity Controlled Crisper Drawer

The right drawer is humidity controlled. This drawer keeps produce fresh longer. Wrap produce tightly. Do not wash produce before placing in drawer. Excess moisture could cause produce to spoil prematurely. Do not line drawer with paper towels. Paper towels will retain moisture.

Humidity control is located below front shelf trim. Control adjusts humidity in drawer. Slide control to right for produce with leaves such as lettuce, spinach or cabbage. Slide control to left for produce with skins such as cauliflower, corn or tomatoes.

Temperature Controlled Drawer

The left drawer is temperature controlled. This drawer keeps food fresh longer and up to 5°F (3°C) colder than Fresh Food temperature. Use this drawer for deli storage or additional produce storage.

Temperature control is located below front shelf trim. Control adjusts amount of air circulating around drawer. Slide control to left for normal Fresh Food temperature and to right for colder temperature. Ice crystals may form on drawer or food on coldest setting. Cold air can decrease Fresh Food temperature. Fresh Food control may need to be adjusted.

Remove shelf and drawers by completing the following steps.

1. Open left* drawer. *For doors hinged on left, open right drawer.



Caution

To avoid personal injury or property damage, handle tempered glass shelves carefully. Shelves may break suddenly if nicked, scratched, or exposed to sudden temperature change.

2. Remove shelf by gently pushing up from underneath. Tilt one end up then pull out.
3. Remove left* drawer by lifting front while supporting underneath then pulling out. *For doors hinged on left, remove right drawer.
4. Remove support post at recess in bottom center of Fresh Food section by lifting.
5. Remove other crisper by sliding to opposite wall. Lift front while supporting underneath then pull out.
6. Replace drawers and shelf by reversing steps 1-5.

Crisper Tote™

Crisper Tote™ provides easy access and protection for small produce such as cherry tomatoes, lemons, mushrooms, etc. in the humidity controlled crisper drawer.

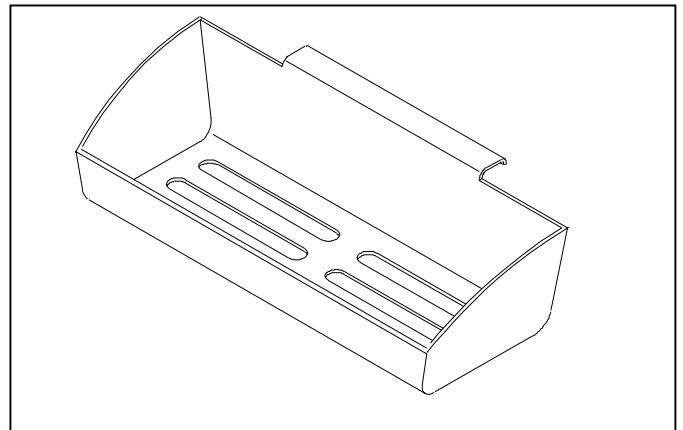

Covered Storage Bucket

Storage bucket has a lid and removable egg tray. When tray is removed, bucket will accept items such as a standard egg carton, ice, etc.

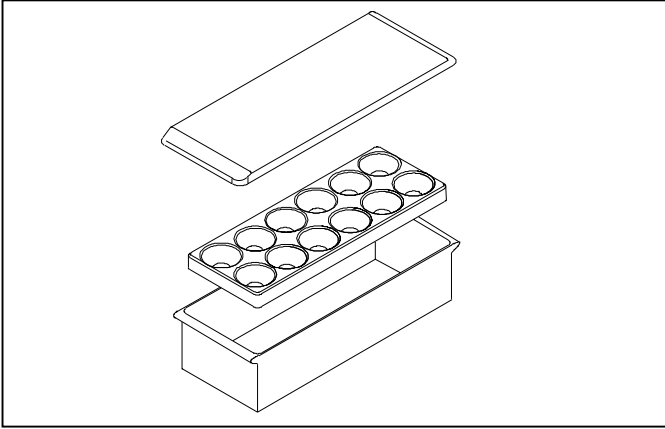

Dairy Centers

Dairy centers provide convenient storage for items such as butter, cheese, etc.

- Remove dairy centers by lifting door, pushing tabs toward center and pulling out.
- Replace dairy centers by sliding in until tabs lock into place and lowering door.

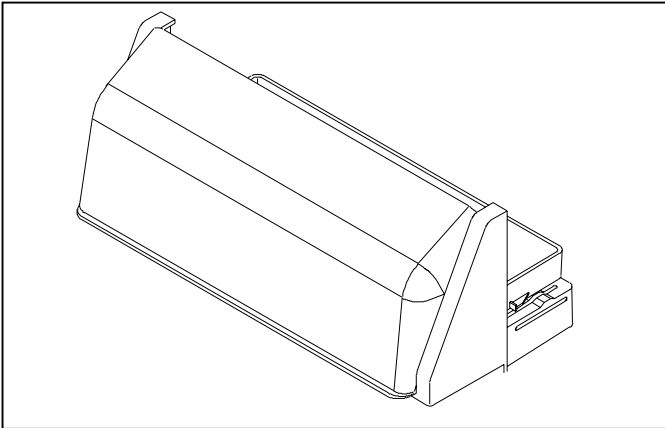

Door Buckets

Door buckets adjust to meet individual storage needs.

- Remove door buckets by pushing tabs toward center and pulling out.
- Replace door buckets by sliding in until tabs lock into place.

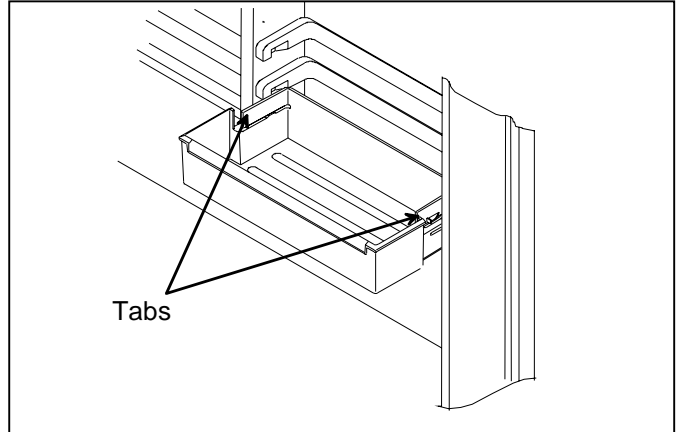

Door Shelf

- Remove door shelf by lifting ends and pulling out.
- Replace door shelf by placing shelf on glides and sliding down.

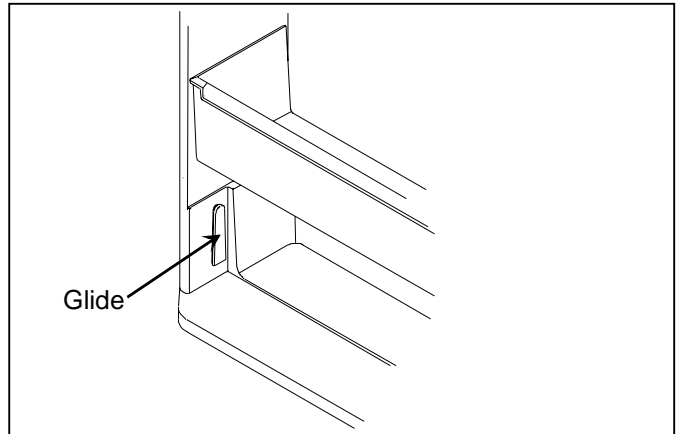

Deepfreeze® Features

Adjustable Dividers

Adjustable dividers keep items in place and adjust to meet individual storage needs. Divider fits in any Fresh Food door bucket or door shelf.

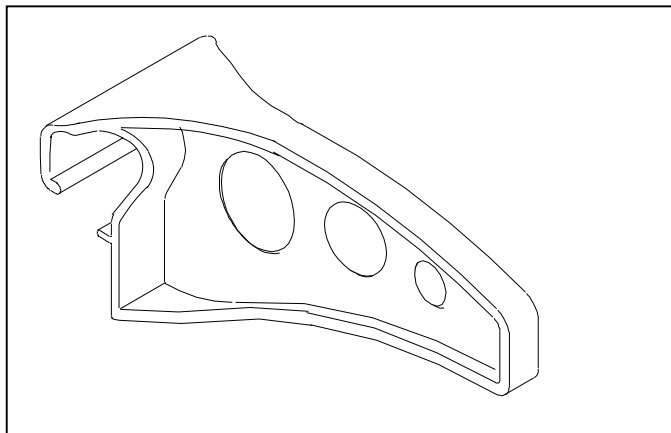

Tall Package Retainer

Tall package retainer keeps tall items secure. Retainer fits in any Fresh Food door bucket or door shelf.

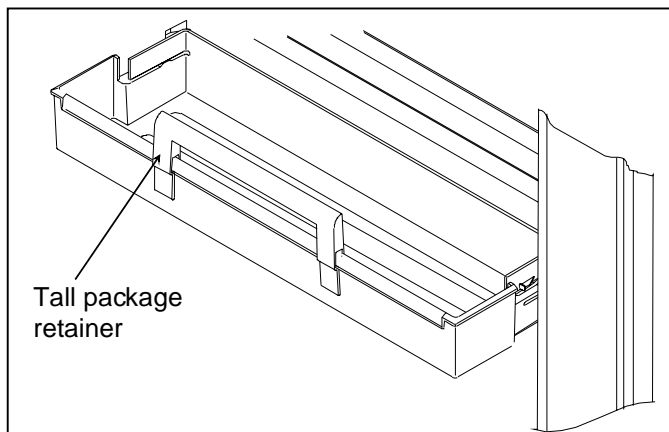

To avoid property damage, confirm shelf is secure before placing items on shelf.

Slide and Serve™ Ice

BBI20 models feature an automatic ice maker, ice bucket, and slide out wire shelf.

- Confirm ice maker arm is down.

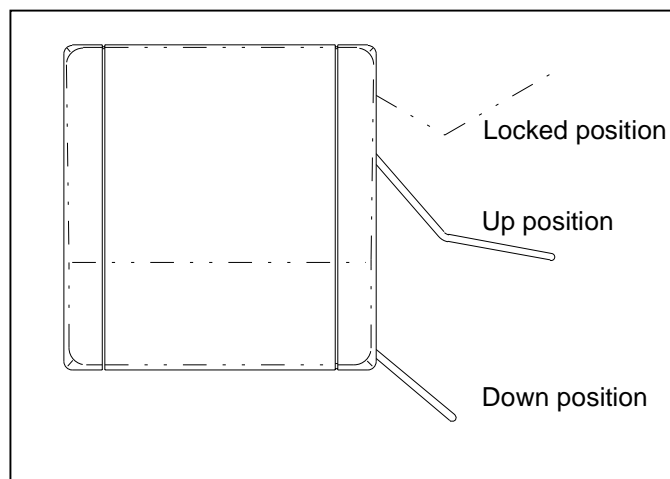

- After Deepfreeze® section reaches normal temperature, ice maker fills with water and begins operating. Allow 24-48 hours after installation before first harvest of ice. Ice maker produces 7 to 9 harvests of ice in a 24-hour period under ideal conditions.
- After ice is formed, ice maker drops ice cubes into ice storage bucket. During ice production, ice maker arm raises and lowers. When ice storage bucket is full, ice maker arm turns ice maker off. Discard first 3 harvests of ice after initially connecting refrigerator to household water supply and after extended periods of non-use.
- Stop ice production by raising ice maker arm. A definite click is heard when proper position is reached. Ice maker arm will remain in that position until pushed down.
- To avoid an ice harvest when shelf is slid out or ice bucket is removed raise ice maker arm to locked position.



To avoid damage to ice maker, observe the following:

- Do not force ice maker arm down or up, past stop position.
- Do not place or store anything in ice storage bucket.

Care and Cleaning

BRF20 models feature an ice bucket, ice cube trays, ice service rack and slide out wire shelf.

- Remove ice service rack by lifting rack off plastic washers then pulling out.
- Replace ice service rack by placing rack on washer and sliding down until secure.

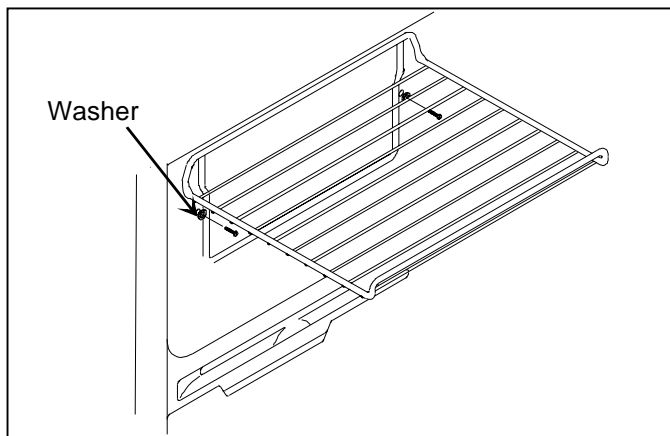

Deepfreeze® Shelf

- Remove Deepfreeze® shelf by pulling out. A sharp tug may be necessary.
- Replace Deepfreeze® shelf by sliding in until back locks in place.

Wire Basket

Wire basket slides out for easy access of items in back.

- Remove wire basket by lifting and pulling out.
- Replace wire basket by sliding in.

Wire Divider

Wire divider organizes storage space. Divider can be moved left or right.

Pivot Bin™

Pivot Bin™ provides convenient storage for frozen food items in Deepfreeze® door and tilts forward for easy access of those items.

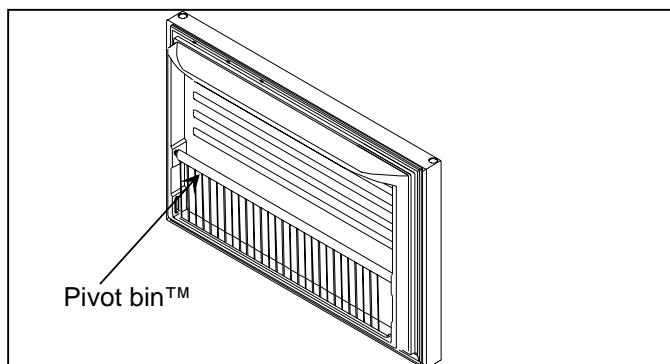

! WARNING

To avoid electrical shock which can cause severe personal injury or death, disconnect power to refrigerator before cleaning. After cleaning, connect power.

! Caution

To avoid personal injury or property damage, read and follow all cleaning product manufacturer's directions.

General

1. Wash surfaces with 4 tablespoons baking soda dissolved in 1 quart warm water and a soft, clean cloth.
2. Rinse surfaces with warm water. Dry surfaces with a soft, clean cloth.
 - Do not use the following items:
 - abrasive or harsh cleaners, ammonia, chlorine bleach, etc.
 - concentrated detergents or solvents
 - metal scouring padsThese items can scratch, crack and discolor surfaces.
 - Do not place buckets, shelves, etc. in dishwasher.

Odor Removal

1. Remove all food.
2. Clean all interior surfaces including ceiling, floor, and walls according to "General" instructions. Pay special attention to corners, crevices, and grooves. Include all drawers, shelves, and gaskets.
3. Wash and dry all bottles, containers and jars before returning food to refrigerator. Wrap foods in tightly sealed containers to prevent further odor. After 24 hours, check if odor was eliminated.

Complete the following steps if odor was not eliminated.

4. Complete steps 1-2.
5. Place garden fresh crispers on top shelf of Fresh Food section. Pack Fresh Food and Deepfreeze® sections including doors with crumpled sheets of black and white newspaper.
6. Place charcoal briquettes randomly throughout newspaper.
7. Close doors and let stand 24-48 hours.
8. Remove charcoal briquettes and newspapers.
9. Complete steps 2-3.

Contact Consumer Affairs Department if odor was still not eliminated.

Adhesives

1. Remove glue residue by rubbing toothpaste into adhesive with fingers until adhesive loosens.
2. Rinse surface with warm water. Dry surface with a soft, clean cloth.

Door Gaskets

1. Clean door gaskets every 3 months according to "General" instructions.
2. Apply a light film of petroleum jelly to keep gaskets pliable.

Condenser Coils

Clean condenser coil every 3 months to ensure maximum performance of refrigerator. Accumulated dust and lint may cause the following:

- reduced cooling performance
 - increased energy usage
 - premature part failure
1. Remove toe grille by holding ends and pulling forward.
 2. Clean front surface of condenser coil with a vacuum cleaner hose nozzle.
 3. Replace toe grille by inserting clips in holes and snapping in.

Glass Shelves

Caution

To avoid personal injury or property damage, handle tempered glass shelves carefully. Shelves may break suddenly if nicked, scratched, or exposed to sudden temperature change.

Remove shelf by lifting front, releasing hooks from metal track then pulling out. Place shelf on a towel. Allow shelf to adjust to room temperature before cleaning.

Clean crevices by completing the following steps:

1. Dilute mild detergent and brush solution into crevices using a plastic bristle brush. Let set for 5 minutes.
2. Spray warm water into crevices using faucet spray attachment.
3. Dry shelf thoroughly and replace shelf by inserting hooks into metal track and lowering front.

Light Bulbs

WARNING

To avoid electrical shock which can cause severe personal injury or death, disconnect power to refrigerator before replacing light bulb. After replacing light bulb, connect power.

Caution

To avoid personal injury or property damage, observe the following:

- Allow light bulb to cool.
 - Wear gloves when replacing light bulb.
-
- Access light bulbs by removing 2 outside back screws. Back of light bulb cover drops down. Replace light bulbs with 40-watt appliance bulbs.
 - Replace light bulb cover by holding cover against ceiling. Insert and tighten screws.

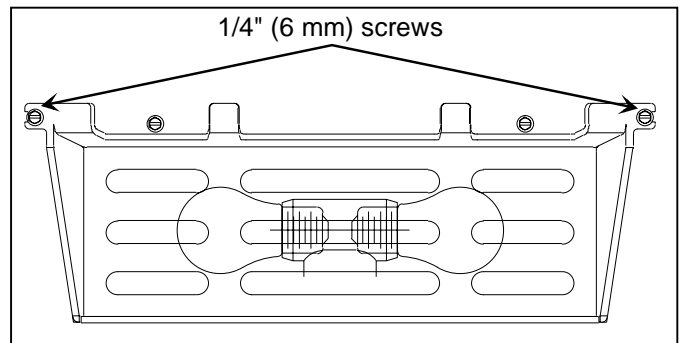

Energy Tips

This refrigerator is designed to be one of the most energy efficient refrigerators available. Reduce energy use by observing the following.

- Operate in normal household temperatures of 55° to 110°F (13°C to 43°C) away from heat sources and direct sunlight.
- Set Fresh Food, Deepfreeze®, and drawer controls no colder than necessary.
- Keep Deepfreeze® section full.
- Keep door gaskets clean and pliable. Replace gaskets if worn.
- Keep condenser coils clean.

Vacation Tips

Complete the following steps for short vacations.

1. Remove perishable foods. **Warranty does not cover food loss.** Check warranty certificate for specific coverage.
2. If an ice maker is installed, move ice maker arm to off position.

Complete the following steps for long vacations.

1. Empty Fresh Food and Deepfreeze® sections.
2. Unplug refrigerator.
3. Clean refrigerator and door gaskets according to “General” instructions in “Care and Cleaning” section.
4. Prop doors open, so air can circulate inside.
5. If an ice maker is installed, turn water supply to refrigerator off and move ice maker arm to off position.

Normal Operating Sounds

This new refrigerator may be replacing a differently designed, less efficient or smaller refrigerator. Today’s refrigerators have new features and are more energy efficient. As a result, certain sounds may be unfamiliar. These sounds are normal and will soon become familiar. These sounds also indicate refrigerator is operating and performing as designed.

- **Deepfreeze® control** clicks when starting or stopping compressor.
- **Deepfreeze® fan** air rushes and whirs.
- **Sealed system** (evaporator and heat exchanger) refrigerant flow gurgles, pops or sounds like boiling water.
- **Defrost heater** sizzles, hisses or pops.
- **Condenser fan** air rushes and whirs.
- **Compressor** has a high pitched hum or pulsating sound.
- **Ice cubes** from ice maker (some models) drop into ice bucket.
- **Ice maker water valve hookup** (some models) buzzes when ice maker fills with water. This occurs whether or not refrigerator is connected to water supply. If refrigerator is not connected to water supply, stop sound by raising ice maker arm to off position.
- Foam insulation is very energy efficient and has excellent insulating capabilities. However, foam insulation is not as sound absorbent as previously used fiberglass insulation.

Before Calling For Service

Refrigerator does not operate.

- Confirm Deepfreeze® control is on.
- Confirm refrigerator is plugged in.
- Check fuse or circuit breaker. Plug in another item at that wall outlet.
- Wait 40 minutes to see if refrigerator restarts. If Deepfreeze® control is on, lights work but 2 fans and compressor are not operating, refrigerator may be in defrost cycle.

Refrigerator still won't operate.

- Unplug refrigerator. Transfer food to another unit or place dry ice in Deepfreeze® section to preserve food. **Warranty does not cover food loss.** Check warranty certificate for specific coverage.
- Call **1-800-628-5782** inside U.S.A. and **1-319-622-5511** outside U.S.A. to locate an authorized Amana technician.

Food temperature appears too warm.

- See above sections.
- Allow time for recently added warm food to reach Fresh Food or Deepfreeze® temperature.
- Check gaskets for proper seal.
- Clean condenser coils.
- Adjust Fresh Food and/or Deepfreeze® control.

Temperature controlled drawer temperature is too warm.

- Slide control to colder setting.
- Adjust Deepfreeze® control to colder setting.

Food temperature is too cold.

- Clean condenser coils.
- Adjust Fresh Food control.
- Adjust Deepfreeze® control to warmer setting. Allow several hours for temperature to adjust.

Refrigerator runs too frequently.

- It may be normal to maintain constant temperature.
- Doors may have been opened frequently or for an extended period of time.
- Allow time for recently added warm food to reach Fresh Food or Deepfreeze® temperature.
- Clean condenser coils.
- Adjust Deepfreeze® control.
- Check gaskets for proper seal.

Water droplets form on inside of refrigerator.

- It is normal during high humidity periods or if doors have been opened frequently.

Water droplets form on outside of refrigerator.

- Check door gaskets for proper seal.

Drawers do not close freely.

- Check for a package which may prevent drawer from closing properly.
- Confirm drawer is in proper position.
- Clean drawer channels with warm, soapy water. Rinse and dry thoroughly.
- Apply a thin layer of petroleum jelly to drawer channels.
- Confirm refrigerator is level.

Refrigerator has an odor.

- See "Odor Removal" instructions in "Care and Cleaning" section.

Refrigerator or ice maker (some models) make unfamiliar sounds or seems too loud.

- It may be normal. See "Normal Operating Sounds" section.

Ice maker (some models) is not producing ice.

- Confirm ice maker arm is down.
- Confirm household water supply is reaching water valve.
- Confirm ice maker wiring harness is completely inserted into proper holes.
- Check for kinks in copper or plastic tubing. Remove kinks or replace tubing.
- Check electrical connections to water valve coil and connector block on refrigerator cabinet.
- Confirm Deepfreeze® section is operating at proper temperature.

Ice cubes have an odor.

- See "Odor Removal" instructions in "Care and Cleaning" section.
- Discard ice and clean ice bucket or trays more frequently. Ice cubes are porous and absorb odors easily.

Ice cubes stick together or 'shrink'.

- Empty ice cube bucket or trays more frequently. If used infrequently, ice cubes may stick together or shrink.

Ice forms in inlet tube to ice maker (some models).

- Check water pressure. Low water pressure will cause valve to leak. Self-piercing valves cause low water pressure. **Amana recommends using a saddle valve. Contact 1-800-843-0304 or an Amana dealer for availability. Do not use self-piercing valve. Amana is not responsible for property damage due to improper installation or water connection.**

Factory Service Centers

Asure™ Service Plan

Listed below are Factory Service Centers which service most metropolitan and surrounding areas. Amana also has a network of independent authorized technicians. Locate a Factory Service Center or independent authorized technician by calling **1-800-628-5782** inside U.S.A. and **1-319-622-5511** outside U.S.A. When contacting Amana, provide product information. Product information is on the serial plate, located on ceiling of Fresh Food section. Warranty service must be performed by an **authorized** Amana technician. Amana Refrigeration, Inc. also recommends contacting an **authorized** Amana technician if service is required after warranty expires.

Amana Refrigeration, Inc. is pleased to offer long-term service protection on this new refrigerator. Asure™ Extended Service Plan is specially designed to supplement Amana's strong warranty. Asure™ provides budget-protecting coverage on refrigerator for up to 5 full years and includes parts, labor and travel charges. A participating Amana® dealer has details.

- **Amana Factory Service Center Arizona**
Also dispatches service in areas of Nevada
- **Amana Factory Service Center Southern California**
- **Amana Factory Service Center Colorado**
Also dispatches service in areas of Utah
- **Amana Factory Service Center Florida**
- **Amana Factory Service Center Georgia**
Also dispatches service in areas of Alabama, North Carolina, South Carolina, and Tennessee
- **Amana Factory Service Center Iowa**
Also dispatches service in areas of Kansas, Minnesota, Missouri, and Wisconsin
- **Amana Factory Service Center Illinois**
Also dispatches service in areas of Indiana and Kentucky
- **Amana Factory Service Center Massachusetts**
Also dispatches service in areas of New Hampshire and Rhode Island
- **Amana Factory Service Center Maryland**
Also dispatches service in areas of Pennsylvania, Virginia, and Washington D.C.
- **Amana Factory Service Center New York**
Also dispatches service in areas of Connecticut and New Jersey
- **Amana Factory Service Center Ohio**
Also dispatches service in areas of Michigan and Pennsylvania
- **Amana Factory Service Center Texas**

Warranty

Full One Year Warranty Full Five Year Warranty on Sealed System Components and Food Compartment Liner Limited Ten Year Warranty on Sealed System Components

First Year

Amana will repair or replace, free of charge, any part which is defective due to workmanship or materials.

Second through Fifth Years

Amana will repair or replace, free of charge, any sealed system component (compressor, condenser, evaporator and interconnecting tubing) and repair any food compartment liner (exclusive of door liner) which is defective due to workmanship or materials.

Sixth through Tenth Years

Amana will replace any sealed system component (compressor, condenser, evaporator and interconnecting tubing), f.o.b. Amana, Iowa, which is defective due to workmanship or materials.

Warranty Limitations

- Begins at date of original purchase.
- Applies to product used within the United States or in Canada if product has Canadian Standards Association listing when shipped from the factory.
- Service must be performed by an **authorized** Amana technician.

Warranty Is Void If

- Serial plate is defaced.
- Product is used on a commercial, rental or leased basis.
- Product has defect or damage due to product accident, alteration, connection to an improper electrical supply, fire, flood, lightning, shipping and handling, or other conditions beyond the control of Amana.
- Product is improperly installed or used.

Owner's Responsibilities

- Provide proof of purchase (sales receipt).
- Provide normal care and maintenance. Replace owner replaceable items where directions appear in Owner's Manual.
- Make product reasonably accessible for service.
- Pay premium service costs for service outside technician's normal business hours.
- Pay for service calls related to product installation.

In no event shall Amana be liable for incidental or consequential damages including food loss*.

*This warranty gives you specific legal rights and you may have others which vary from state to state. For example, some states do not allow the exclusion or limitation of incidental or consequential damages so this exclusion may not apply to you.