

DENON

AV SURROUND RECEIVER

AVR-5805CI

OPERATING INSTRUCTIONS

SAFETY PRECAUTIONS



CAUTION
RISK OF ELECTRIC SHOCK
DO NOT OPEN



CAUTION: TO REDUCE THE RISK OF ELECTRIC SHOCK, DO NOT REMOVE COVER (OR BACK). NO USER-SERVICEABLE PARTS INSIDE. REFER SERVICING TO QUALIFIED SERVICE PERSONNEL.

The lightning flash with arrowhead symbol, within an equilateral triangle, is intended to alert the user to the presence of uninsulated "dangerous voltage" within the product's enclosure that may be of sufficient magnitude to constitute a risk of electric shock to persons.

The exclamation point within an equilateral triangle is intended to alert the user to the presence of important operating and maintenance (servicing) instructions in the literature accompanying the appliance.

WARNING: TO REDUCE THE RISK OF FIRE OR ELECTRIC SHOCK, DO NOT EXPOSE THIS APPLIANCE TO RAIN OR MOISTURE.

FCC INFORMATION (For US customers)

1. COMPLIANCE INFORMATION
 Product Name: AV Surround Receiver
 Model Number: AVR-5805CI

This product complies with Part 15 of the FCC Rules. Operation is subject to the following two conditions: (1) this product may not cause harmful interference, and (2) this product must accept any interference received, including interference that may cause undesired operation.

Denon Electronics (USA), LLC
 (a D & M Holdings Company)
 100 Corporate Drive
 Mahwah, NJ 07430-2041
 Tel. (800) 497-8921





2. IMPORTANT NOTICE: DO NOT MODIFY THIS PRODUCT
 This product, when installed as indicated in the instructions contained in this manual, meets FCC requirements. Modification not expressly approved by DENON may void your authority, granted by the FCC, to use the product.

3. NOTE
 This product has been tested and found to comply with the limits for a Class B digital device, pursuant to Part 15 of the FCC Rules. These limits are designed to provide reasonable protection against harmful interference in a residential installation.
 This product generates, uses and can radiate radio frequency energy and, if not installed and used in accordance with the instructions, may cause harmful interference to radio communications. However, there is no guarantee that interference will not occur in a particular installation. If this product does cause harmful interference to radio or television reception, which can be determined by turning the product OFF and ON, the user is encouraged to try to correct the interference by one or more of the following measures:

- Reorient or relocate the receiving antenna.
- Increase the separation between the equipment and receiver.
- Connect the product into an outlet on a circuit different from that to which the receiver is connected.
- Consult the local retailer authorized to distribute this type of product or an experienced radio/TV technician for help.

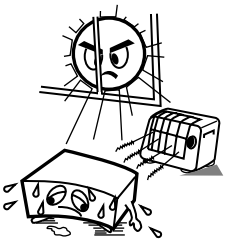
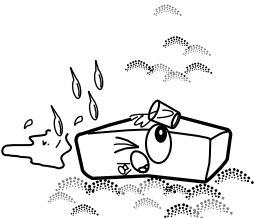
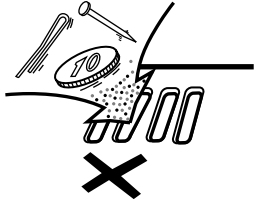
This Class B digital apparatus complies with Canadian ICES-003.
 Cet appareil numérique de la classe B est conforme à la norme NMB-003 du Canada.

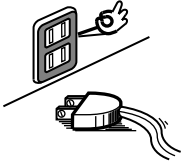
NOTE ON USE / OBSERVATIONS RELATIVES A L'UTILISATION

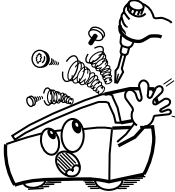
 <ul style="list-style-type: none"> • Avoid high temperatures. Allow for sufficient heat dispersion when installed in a rack. • Eviter des températures élevées. Tenir compte d'une dispersion de chaleur suffisante lors de l'installation sur une étagère. 	 <ul style="list-style-type: none"> • Keep the apparatus free from moisture, water, and dust. • Protéger l'appareil contre l'humidité, l'eau et la poussière. 	 <ul style="list-style-type: none"> • Do not let foreign objects into the apparatus. • Ne pas laisser des objets étrangers dans l'appareil.
 <ul style="list-style-type: none"> • Handle the power cord carefully. Hold the plug when unplugging the cord. • Manipuler le cordon d'alimentation avec précaution. Tenir la prise lors du débranchement du cordon. 	 <ul style="list-style-type: none"> • Unplug the power cord when not using the apparatus for long periods of time. • Débrancher le cordon d'alimentation lorsque l'appareil n'est pas utilisé pendant de longues périodes. 	 <ul style="list-style-type: none"> • Do not let insecticides, benzene, and thinner come in contact with the apparatus. • Ne pas mettre en contact des insecticides, du benzène et un diluant avec l'appareil.
 <p style="text-align: center;">* (For apparatuses with ventilation holes)</p> <ul style="list-style-type: none"> • Do not obstruct the ventilation holes. • Ne pas obstruer les trous d'aération. 	 <ul style="list-style-type: none"> • Never disassemble or modify the apparatus in any way. • Ne jamais démonter ou modifier l'appareil d'une manière ou d'une autre. 	

SAFETY INSTRUCTIONS

1. Read Instructions – All the safety and operating instructions should be read before the product is operated.
2. Retain Instructions – The safety and operating instructions should be retained for future reference.
3. Heed Warnings – All warnings on the product and in the operating instructions should be adhered to.
4. Follow Instructions – All operating and use instructions should be followed.
5. Cleaning – Unplug this product from the wall outlet before cleaning. Do not use liquid cleaners or aerosol cleaners.
6. Attachments – Do not use attachments not recommended by the product manufacturer as they may cause hazards.
7. Water and Moisture – Do not use this product near water – for example, near a bath tub, wash bowl, kitchen sink, or laundry tub; in a wet basement; or near a swimming pool; and the like.
8. Accessories – Do not place this product on an unstable cart, stand, tripod, bracket, or table. The product may fall, causing serious injury to a child or adult, and serious damage to the product. Use only with a cart, stand, tripod, bracket, or table recommended by the manufacturer, or sold with the product. Any mounting of the product should follow the manufacturer's instructions, and should use a mounting accessory recommended by the manufacturer.
9. A product and cart combination should be moved with care. Quick stops, excessive force, and uneven surfaces may cause the product and cart combination to overturn.
10. Ventilation – Slots and openings in the cabinet are provided for ventilation and to ensure reliable operation of the product and to protect it from overheating, and these openings must not be blocked or covered. The openings should never be blocked by placing the product on a bed, sofa, rug, or other similar surface. This product should not be placed in a built-in installation such as a bookcase or rack unless proper ventilation is provided or the manufacturer's instructions have been adhered to.
11. Power Sources – This product should be operated only from the type of power source indicated on the marking label. If you are not sure of the type of power supply to your home, consult your product dealer or local power company. For products intended to operate from battery power, or other sources, refer to the operating instructions.
12. Grounding or Polarization – This product may be equipped with a polarized alternating-current line plug (a plug having one blade wider than the other). This plug will fit into the power outlet only one way. This is a safety feature. If you are unable to insert the plug fully into the outlet, try reversing the plug. If the plug should still fail to fit, contact your electrician to replace your obsolete outlet. Do not defeat the safety purpose of the polarized plug.



13. Power-Cord Protection – Power-supply cords should be routed so that they are not likely to be walked on or pinched by items placed upon or against them, paying particular attention to cords at plugs, convenience receptacles, and the point where they exit from the product.
15. Outdoor Antenna Grounding – If an outside antenna or cable system is connected to the product, be sure the antenna or cable system is grounded so as to provide some protection against voltage surges and built-up static charges. Article 810 of the National Electrical Code, ANSI/NFPA 70, provides information with regard to proper grounding of the mast and supporting structure, grounding of the lead-in wire to an antenna discharge unit, size of grounding conductors, location of antenna-discharge unit, connection to grounding electrodes, and requirements for the grounding electrode. See Figure A.
16. Lightning – For added protection for this product during a lightning storm, or when it is left unattended and unused for long periods of time, unplug it from the wall outlet and disconnect the antenna or cable system. This will prevent damage to the product due to lightning and power-line surges.
17. Power Lines – An outside antenna system should not be located in the vicinity of overhead power lines or other electric light or power circuits, or where it can fall into such power lines or circuits. When installing an outside antenna system, extreme care should be taken to keep from touching such power lines or circuits as contact with them might be fatal.
18. Overloading – Do not overload wall outlets, extension cords, or integral convenience receptacles as this can result in a risk of fire or electric shock.
19. Object and Liquid Entry – Never push objects of any kind into this product through openings as they may touch dangerous voltage points or short-out parts that could result in a fire or electric shock. Never spill liquid of any kind on the product.
20. Servicing – Do not attempt to service this product yourself as opening or removing covers may expose you to dangerous voltage or other hazards. Refer all servicing to qualified service personnel.
21. Damage Requiring Service – Unplug this product from the wall outlet and refer servicing to qualified service personnel under the following conditions:
 - a) When the power-supply cord or plug is damaged,
 - b) If liquid has been spilled, or objects have fallen into the product,
 - c) If the product has been exposed to rain or water,
 - d) If the product does not operate normally by following the operating instructions. Adjust only those controls that are covered by the operating instructions as an improper adjustment of other controls may result in damage and will often require extensive work by a qualified technician to restore the product to its normal operation,
 - e) If the product has been dropped or damaged in any way, and
 - f) When the product exhibits a distinct change in performance – this indicates a need for service.
22. Replacement Parts – When replacement parts are required, be sure the service technician has used replacement parts specified by the manufacturer or have the same characteristics as the original part. Unauthorized substitutions may result in fire, electric shock, or other hazards.
23. Safety Check – Upon completion of any service or repairs to this product, ask the service technician to perform safety checks to determine that the product is in proper operating condition.
24. Wall or Ceiling Mounting – The product should be mounted to a wall or ceiling only as recommended by the manufacturer.
25. Heat – The product should be situated away from heat sources such as radiators, heat registers, stoves, or other products (including amplifiers) that produce heat.

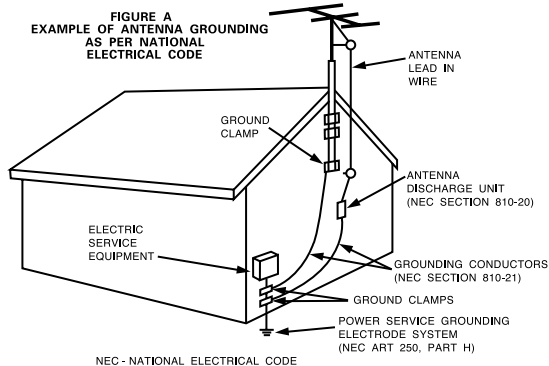

Getting Started

Thank you for choosing the DENON AVR-5805CI AV Surround Receiver. This remarkable component has been engineered to provide superb surround sound listening with home theater sources such as DVD, as well as providing outstanding high fidelity reproduction of your favorite music sources.

As this product is provided with an immense array of features, we recommend that before you begin hookup and operation that you review the contents of this manual before proceeding.

Contents

Getting Started		Basic Operation	
Accessories	7	Playback	
Before using	7	Operating the remote control unit	43
Cautions on installation	7	Playing the input source	44
Cautions on handling	8	Turning the sound off temporarily (MUTING)	45
Preparing the remote control unit	8	Listening over headphones	45
Inserting the batteries	8	Switching the surround speakers	45
Operating range of the remote control unit	9	Switching between HDMI and DVI-D monitor output	45
Part names and functions		Selection of resolution setting (SCALE)	45
Front panel	10, 11	Combining the currently playing sound with the desired image (VIDEO SELECT)	45
Display	12	Video on/off	45
Remote control unit	13	Checking the currently playing program source, etc.	46
		Input mode	46 ~ 48
		Room EQ function	48
Easy Setup and Operation		Surround	
Easy to setup flow	14	Playing modes for different sources	49
Speaker system layout	15	Playing audio sources (CDs and DVDs)	
Speaker connections	16, 17	2 channel playback modes	50
Connecting a DVD player and TV (Monitor)	18, 19	THX Surround EX / Home THX Cinema mode	
Auto Setup / Room EQ	20	• Playing sources recorded in Dolby Surround in the Home THX Cinema Surround mode	51
Connecting a microphone	21	• To play in the THX Surround EX / Home THX Cinema Surround mode for sources recorded in Dolby Digital or DTS	51 ~ 53
Turning on the power	22	Dolby Digital mode and DTS Surround (only with digital input)	54, 55
Starting Auto Setup	22	Night mode	55
Extra Setup	23	Dolby Pro Logic IIx (Pro Logic II) mode	56, 57
Preliminary measurements	23, 24	DTS NEO:6 mode	58
Speaker system measurement	24	The Dolby Headphone	59
Check of the measurement result	25	USER MODE function	59
About the error message	26	DENON original surround modes	
		Surround modes and their features	60
Connecting Other Sources		DSP surround simulation	61, 62
Cable indications	27	Tone control setting	
The video conversion function	28	• Adjusting the tone from the remote control unit	62, 63
On screen display for component video outputs and HDMI output	28	• Adjusting the tone from the main unit	63
Connecting equipment with HDMI terminals [To convert analog video signals to HDMI signals]	29	• Tone defeat mode	63
Connecting a TV tuner	30	Channel Level	64
Connecting a DBS tuner	30	Fader function	65
Connecting the external inputs (EXT. IN) terminals	31	Listening to the radio	
Connecting a video camera or video game	31	Auto tuning	65
Connecting a DVD recorder	32	Manual tuning	66
Connecting a VCR	33	Preset memory	66
Connecting a CD player	33	Checking the preset stations	67
Connecting a turntable	34	Recalling preset stations	67
Connecting a CD recorder or MD recorder	34	RDS (Radio Data System)	67
Connecting a tape deck	35	RDS search	68
DENON LINK connection	35	PTY search	69
Connecting equipment with HDMI terminals	36	TP search	69, 70
Connecting equipment with DVI-D terminals	37	RT (Radio Text)	70
Connecting IEEE1394 devices	38	XM Satellite Radio	
Connecting the antenna terminals	39	Checking the XM signal strength and Radio ID	71
Connecting the XM terminal	40	Channel selection	72
Connecting the CONTROL terminal	40	Category search	72
Connecting the TRIGGER OUT terminals	41	Direct access of channels	73
Connecting the MULTI ZONE terminals			
ZONE2 connections	41		
Connecting the pre-out terminals	42		
Connecting the power supply cord	42		



■ System Setup Menu

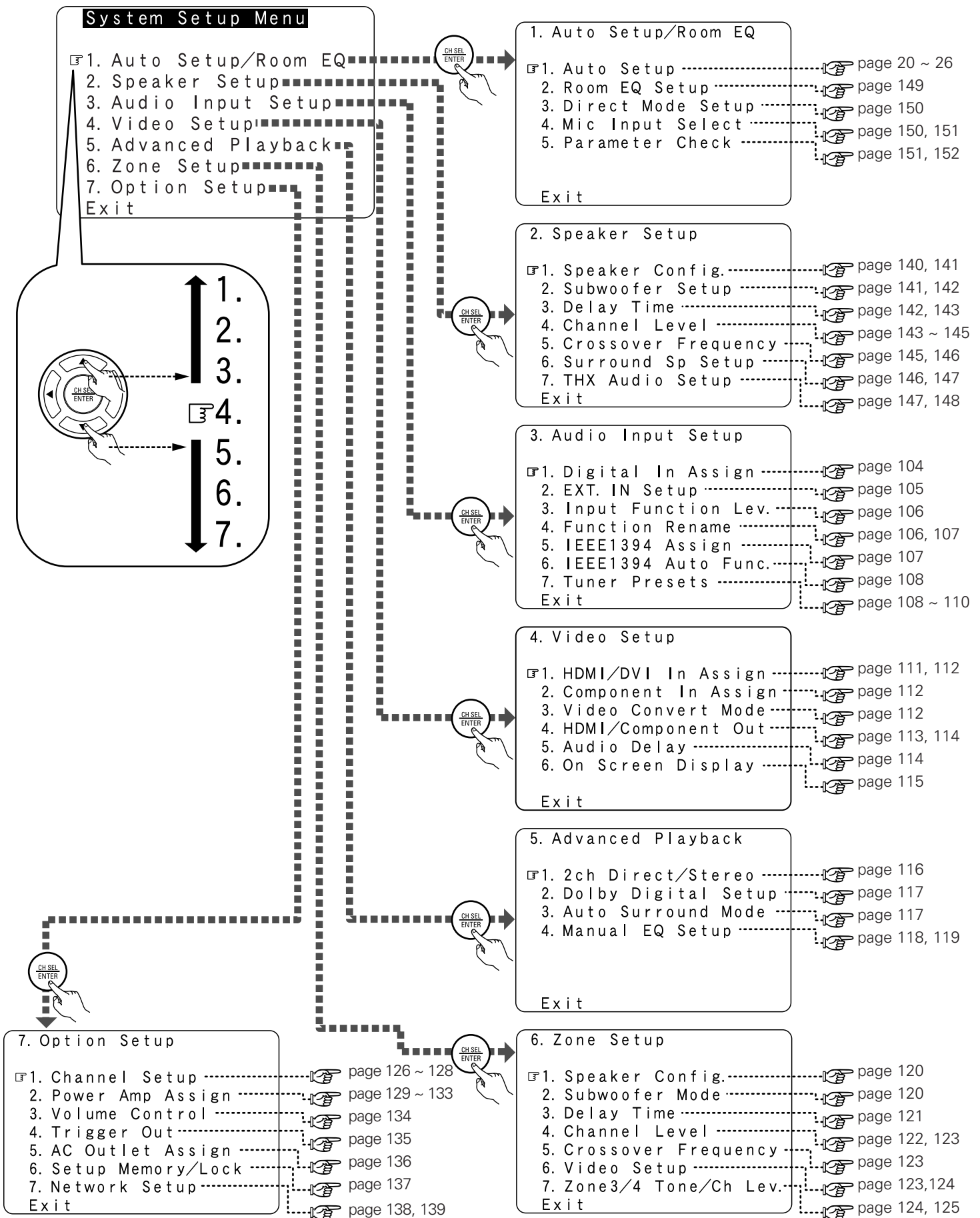

Getting Started

Using the Network Audio Function

Internet radio function.....	74
Music server function.....	74
System requirements.....	74 ~ 76
Listening to Internet radio.....	76, 77
Presetting (registering) Internet radio stations.....	77
Registering Internet radio stations in your favorites.....	77, 78
Character search function (searching by first letter).....	78
Updating the list of radio stations.....	79
Playing music files stored on the computer (music server).....	79, 80
Operating the AVR-5805CI using a browser.....	80

Advanced Operation

Remote control unit

Operating DENON audio components.....	81
Setting the preset memory function.....	82
Operating a component stored in the preset memory.....	82, 83
Setting the learning function.....	84
Using the system call function.....	84
• Registering.....	85
• Operating.....	85
Setting the punch through function.....	85
Setting the back light's lighting time.....	85
Setting the brightness.....	85
Resetting the remote control unit.....	86

Multi zone music entertainment system

ZONE2 playback.....	87 ~ 90
ZONE3 playback.....	91
ZONE4 playback.....	92
Outputting a program source to an amplifier, etc., in a ZONE2 room (ZONE2 SELECT mode).....	93
Outputting a program source to an amplifier, etc., in a ZONE3 or ZONE4 room (ZONE3, ZONE4 SELECT mode).....	93
Remote control unit operations during multi-source playback.....	94
System setup for multi-zone.....	95
Adjustment steps that need to be performed prior to surround sound playback in ZONE2.....	95
• Test Tone.....	95
• Channel Level.....	95
• Fader function.....	96
ZONE2 Surround.....	97
USER MODE function of ZONE2.....	97
ZONE2 tone control setting.....	98

Other function

Playing Super Audio CDs with an IEEE1394 cable.....	99
Multi-source recording / playback.....	
• Playing one source while recording another (REC OUT mode).....	100
• Recording Dolby Digital and DTS multi channel sources.....	100
• Dolby Headphone recording.....	101
Last function memory.....	101
Initialization of the microprocessor.....	101

Advanced Setup – Part 1

Navigating through the System Setup Menu.....

On screen display and front display.....

Audio Input Setup

Setting the Digital In Assignment.....	104
• Setting the DENON LINK.....	104
Setting the EXT. IN Setup.....	105
Setting the Input Function Level.....	106
Setting the Function Rename.....	106, 107
Setting the IEEE1394 Assignment.....	107
Setting the IEEE1394 Auto Function.....	108
Tuner Presets.....	
• Auto Preset Memory.....	108
• Preset Skip.....	109
• Preset Name.....	109, 110

Video Setup

Setting the HDMI/DVI In Assignment.....	111, 112
Setting the Component In Assignment.....	112
Setting the Video Convert Mode.....	112
Setting the HDMI/Component Out Setup.....	113, 114
Setting the Audio Delay.....	114
Setting the On Screen Display (OSD).....	115

Advanced Playback

Setting the 2ch Direct/Stereo.....	116
Setting the Dolby Digital Setup.....	117
Setting the Auto Surround Mode.....	117
Setting the Manual EQ Setup.....	118, 119
• Procedure for copying the "Flat" correction curve.....	119

Zone Setup (ZONE2 = 5.1/7.1ch)

Setting the type of speakers for ZONE2.....	120
Setting the low frequency distribution for ZONE2.....	120
Setting the Delay Time for ZONE2.....	121
Setting the Channel Level for ZONE2.....	122, 123
Setting the Crossover Frequency for ZONE2.....	123
Setting the Video Setup for ZONE2.....	
• Video Convert Mode (ZONE2).....	123
• Audio Delay (ZONE2).....	124
Setting the ZONE3 and ZONE4 tone control and channel level.....	124, 125

Option Setup

Setting the Channel Setup.....	126 ~ 128
Setting the Power Amplifier Assignment.....	129 ~ 133
Setting the Volume Control.....	134
Setting the Trigger Out.....	135
Setting the AC Outlet Assignment.....	136
Memory backup and protecting the setting.....	137
Setting the Network Setup.....	138, 139

Advanced Setup – Part 2

Speaker Setup

Setting the type of speakers.....	140, 141
Setting the low frequency distribution.....	141, 142
Setting the Delay Time.....	142, 143
Setting the Channel Level.....	143 ~ 145
• Adjusting the test tone using the remote control unit.....	145
Setting the Crossover Frequency.....	145, 146
• Setting the crossover frequency individually for the different channels.....	146
Selecting the Surround Speakers for the different surround modes.....	146, 147
Settings the THX Audio Setup.....	
• Settings for using a THX Ultra2 compatible subwoofer.....	147
• Surround Back Speaker Position Settings.....	148

Others Setup

Setting the Room EQ Setup.....	149
Setting the Direct Mode Setup.....	150
Setting the MIC Input Select.....	150, 151
Check the parameter.....	151, 152
System setup items and default values.....	153 ~ 156

Troubleshooting..... 157, 158

Additional information..... 159 ~ 173

Specifications..... 174, 175

List of preset codes.....End of this manual

Accessories

- Check that the following parts are included in addition to the main unit:

① Operating instructions	1	⑤ Remote control unit (RC-1036)	1
② Warranty (for North America model only).....	1	⑥ LR6/AA alkaline batteries.....	2
③ Service station list.....	1	⑦ AM loop antenna	1
④ Power supply cord.....	1	⑧ FM indoor antenna.....	1

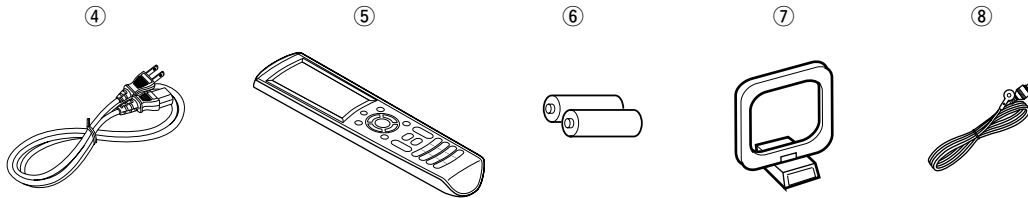

Before using

Pay attention to the following before using this unit:

- **Moving the set**

To prevent short circuits or damaged wires in the connection cables, always unplug the power supply cord and disconnect the connection cables between all other audio components when moving the set.

- **Before turning the Power operation button on**

Check once again that all connections are proper and that there are not problems with the connection cables. Always set the power operation button to the standby position before connecting and disconnecting connection cables.

- **Store these instructions in a safe place.**

After reading, store these instructions along with the warranty in a safe place.

- **Note that the illustrations in these instructions may differ from the actual set for explanation purposes.**

Cautions on installation

Noise or disturbance of the picture may be generated if this unit or any other electronic equipment using microprocessors is used near a tuner or TV.

If this happens, take the following steps:

- Install this unit as far as possible from the tuner or TV.
- Set the antenna wires from the tuner or TV away from this unit's power supply cord and input/output connection cables.
- Noise or disturbance tends to occur particularly when using indoor antennas or 300 Ω /ohms feeder wires. **We recommend using outdoor antennas and 75 Ω /ohms coaxial cables.**

Note:

For heat dispersal, do not install this unit in a confined space such as a bookcase or similar enclosure.

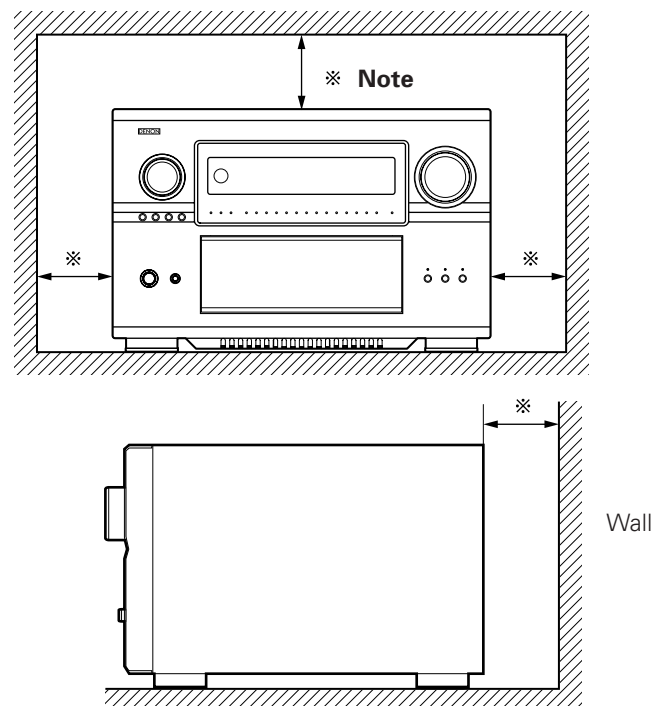

Getting Started

Cautions on handling

- **Switching the input function when input terminals are not connected.**

A clicking noise may be produced if the input function is switched when nothing is connected to the input terminals. If this happens, either turn down the MASTER VOLUME control knob or connect components to the input terminals.

- **Muting of PRE OUT terminals and SPEAKER terminals.**

The PRE OUT terminals and SPEAKER terminals include a muting circuit. Because of this, the output signals are greatly reduced for several seconds after the power switch is turned on or input function, surround mode or any other set-up is changed. If the volume is turned up during this time, the output will be very high after the muting circuit stops functioning. Always wait until the muting circuit turns off before adjusting the volume.

- **Whenever the power operation button is in the STANDBY state, the apparatus is still connected on AC line voltage.**

Please be sure to turn off the power switch or unplug the cord when you leave home for, say, a vacation.

Preparing the remote control unit

- The included remote control unit (RC-1036) can be used to operate not only the AVR-5805CI but other remote control compatible DENON components as well. In addition, the memory contains the control signals for other remote control units, so it can be used to operate non-DENON remote control compatible products.

Inserting the batteries

- ① Remove the remote control unit's rear cover.

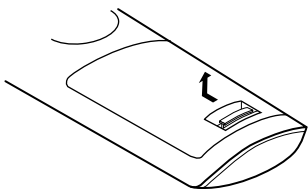

- ② Set two LR6/AA batteries in the battery compartment in the indicated direction.

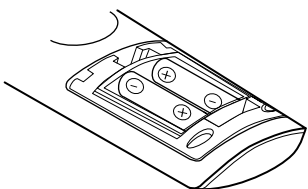

- ③ Put the rear cover back on.

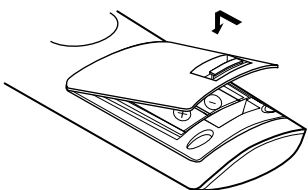

Notes on batteries:

- Replace the batteries with new ones if the set does not operate even when the remote control unit is operated nearby the set. (The included battery is only for verifying operation.)
- When inserting the batteries, be sure to do so in the proper direction, following the "⊕" and "⊖" marks in the battery compartment.
- To prevent damage or leakage of battery fluid:
 - Do not use a new battery together with an old one.
 - Do not use two different types of batteries.
 - Do not short-circuit, disassemble, heat or dispose of batteries in flames.
- Remove the batteries from the remote if it will not be in use for long periods.
- If the battery fluid should leak, carefully wipe the fluid off the inside of the battery compartment and insert new batteries.
- When replacing the batteries, have the new batteries ready and insert them as quickly as possible.

Operating range of the remote control unit

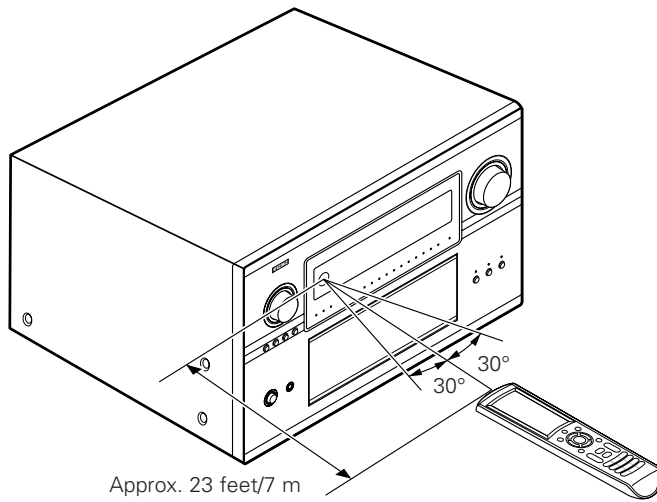

- Point the remote control unit at the remote sensor on the main unit as shown on the diagram.
- The remote control unit can be used from a straight distance of approximately 23 feet/7 meters from the main unit, but this distance will be shorter if there are obstacles in the way or if the remote control unit is not pointed directly at the remote sensor.
- The remote control unit can be operated at a horizontal angle of up to 30 degrees with respect to the remote sensor.

NOTE:

- It may be difficult to operate the remote control unit if the remote sensor is exposed to direct sunlight or strong artificial light.
- Do not press buttons on the main unit and remote control unit simultaneously. Doing so may result in malfunction.
- Neon signs or other devices emitting pulse-type noise nearby may result in malfunction, so keep the set as far away from such devices as possible.

Part names and functions

Front panel

- For details on the functions of these parts, refer to the pages given in parentheses ().

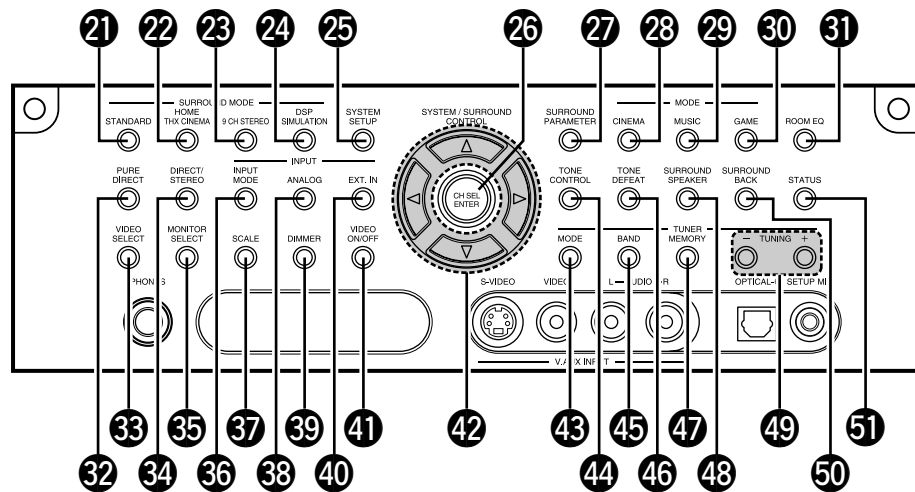
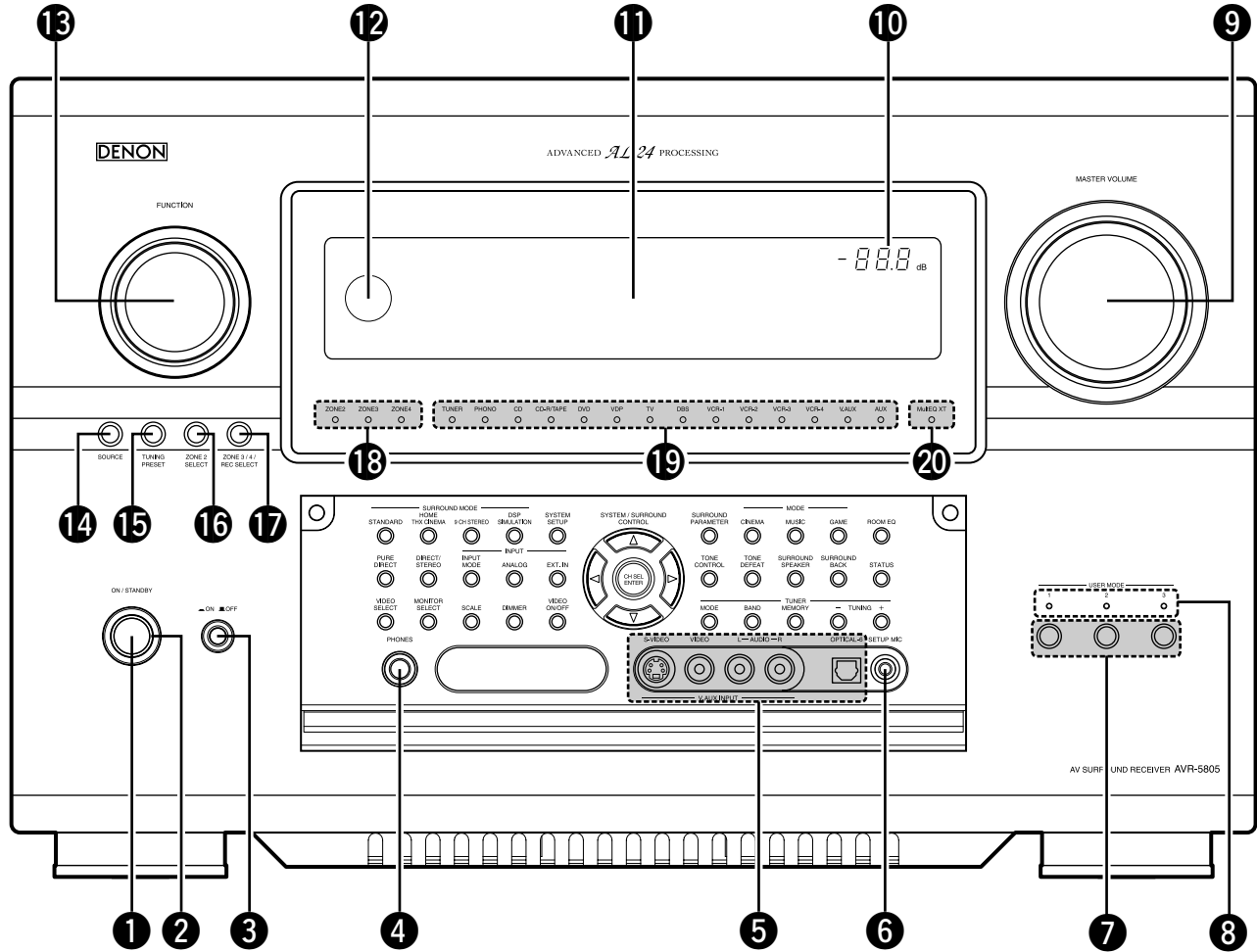

1 Power ON/STANDBY button	(22)	27 SURROUND PARAMETER button	(50)
2 Power indicator	(22)	28 CINEMA button	(56)
3 Power switch	(22, 101)	29 MUSIC button	(56)
4 Headphones jack (PHONES)	(45)	30 GAME button	(56)
5 V.AUX INPUT terminals	(31)	31 ROOM EQ button	(48)
6 SETUP MIC jack	(21)	32 PURE DIRECT button	(50)
7 USER MODE buttons	(60)	33 VIDEO SELECT button	(46)
8 USER MODE indicators	(60)	34 DIRECT/STEREO button	(50)
9 MASTER VOLUME control knob	(44)	35 MONITOR SELECT button	(45)
10 Master volume indicator	(44)	36 INPUT MODE button	(47)
11 Display	(12)	37 SCALE button	(45)
12 Remote control sensor	(9)	38 ANALOG button	(47)
13 FUNCTION knob	(44)	39 DIMMER button	(46)
14 SOURCE button	(44)	40 EXT.IN button	(47)
15 TUNING PRESET button	(67)	41 VIDEO ON/OFF button	(46)
16 ZONE2 SELECT button	(93)	42 CURSOR buttons	(22)
17 ZONE3/4/REC SELECT button	(93, 100)	43 MODE button	(65)
18 Multi Zone power indicators	(94)	44 TONE CONTROL button	(63)
19 Input source indicators	(44)	45 BAND button	(65)
20 MultEQ XT indicator	(48)	46 TONE DEFEAT button	(63)
21 STANDARD button	(54)	47 MEMORY button	(66)
22 HOME THX CINEMA button	(44)	48 SURROUND SPEAKER button	(45)
23 9CH STEREO button	(62)	49 TUNING buttons	(65)
24 DSP SIMULATION button	(62)	50 SURROUND BACK button	(52)
25 SYSTEM SETUP button	(22)	51 STATUS button	(46)
26 CH SELECT/ENTER button	(22, 64)		

Display

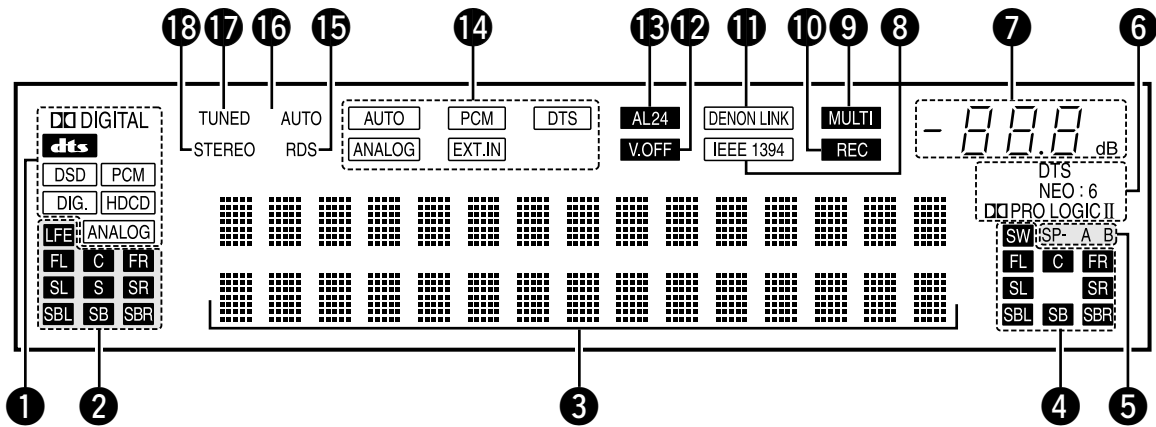
**1 Input signal indicator**

The respective indicator will light corresponding to the input signal.

2 Input signal channel indicator

The channels included in the input source will light. This lights when the digital signal is input.

3 Information display

This displays the surround mode, function name or setting value, etc.

4 Output signal channel indicator

The audio channels that can be output light.

5 Speaker indicator

This lights corresponding to the settings of the surround speakers of the various surround modes.

6 Decoder indicator

This lights when each decoder is operating.

7 Master volume indicator

This displays the volume level. The Setup item number is displayed in System Setup.

8 IEEE1394 indicator

This lights during playback in a IEEE1394 connection.

9 MULTI (zone) indicator

ZONE3 mode is selected in ZONE3/REC SELECT.

10 Recording output source indicator

REC OUT mode is selected in ZONE3/REC SELECT.

11 DENON LINK indicator

This lights during playback in a DENON LINK connection.

12 V.OFF indicator

This lights when the operation of the video circuit has been turned off.

13 AL24 indicator

The AL24 indicator lights when the PURE DIRECT, DIRECT, STEREO, MULTI CH PURE DIRECT, MULTI CH DIRECT, MULTI CH IN mode is selected in the PCM input signal.

14 Input mode indicator

This lights corresponding to the setting of the INPUT mode.

15 RDS indicator

This lights when RDS broadcast has been received.

16 AUTO indicator

This lights when the broadcast station is selected in the AUTO tuning mode.

17 TUNED indicator

This lights when an FM/AM broadcast has been received.

18 STEREO indicator

This lights when an FM stereo broadcast has been received.

Remote control unit

- For details on the functions of these parts, refer to the pages given in parentheses ().

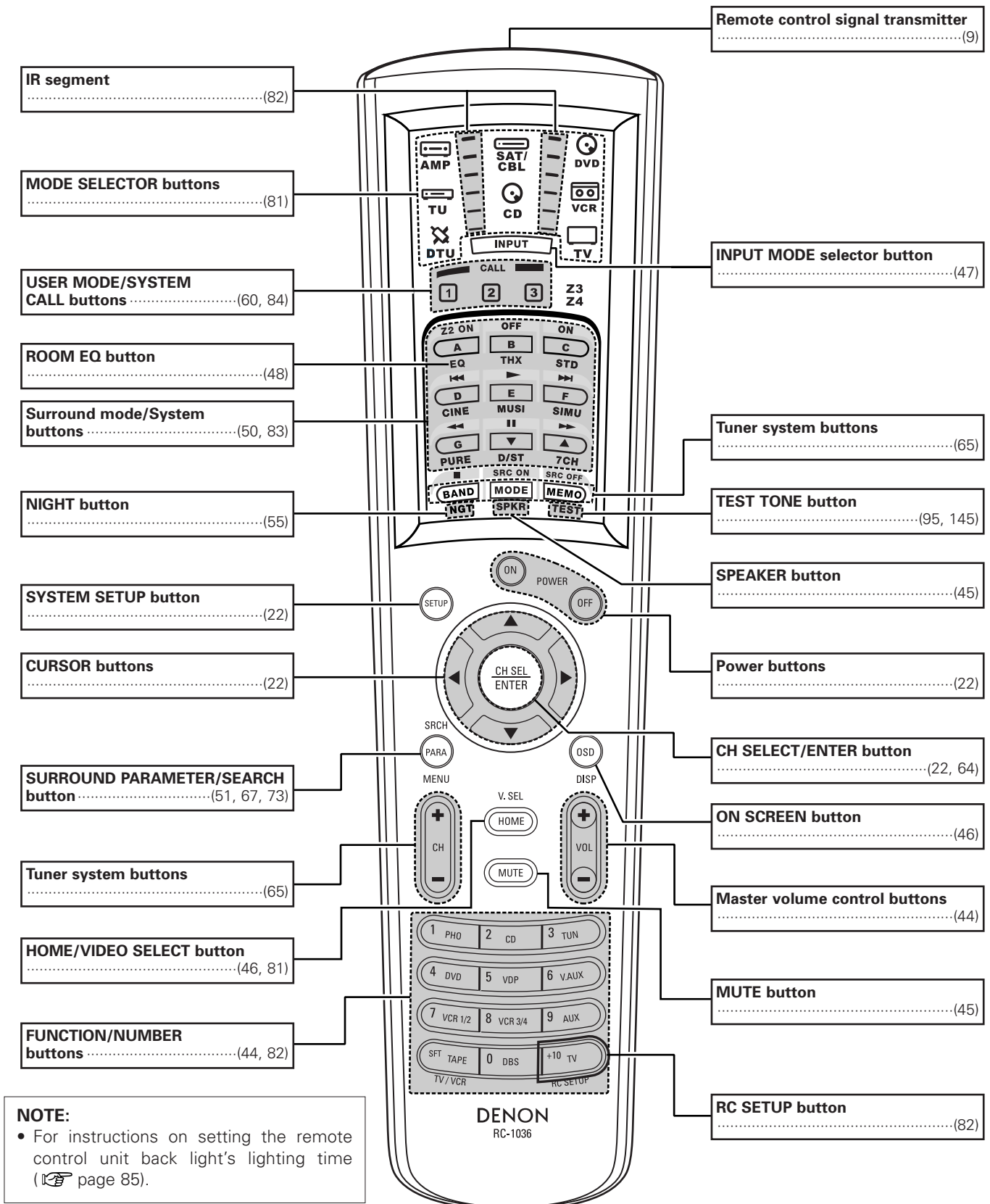

NOTE:

- For instructions on setting the remote control unit back light's lighting time (👉 page 85).



Easy Setup and Operation

- This section contains the basic steps necessary to configure the AVR-5805CI according to your listening room environment and the source equipment and loudspeakers you are using.
- For optimum performance, we recommend using the Auto Setup function.
- If you wish, you can set the various settings manually without using Auto Setup (👉 page 140 ~ 148).

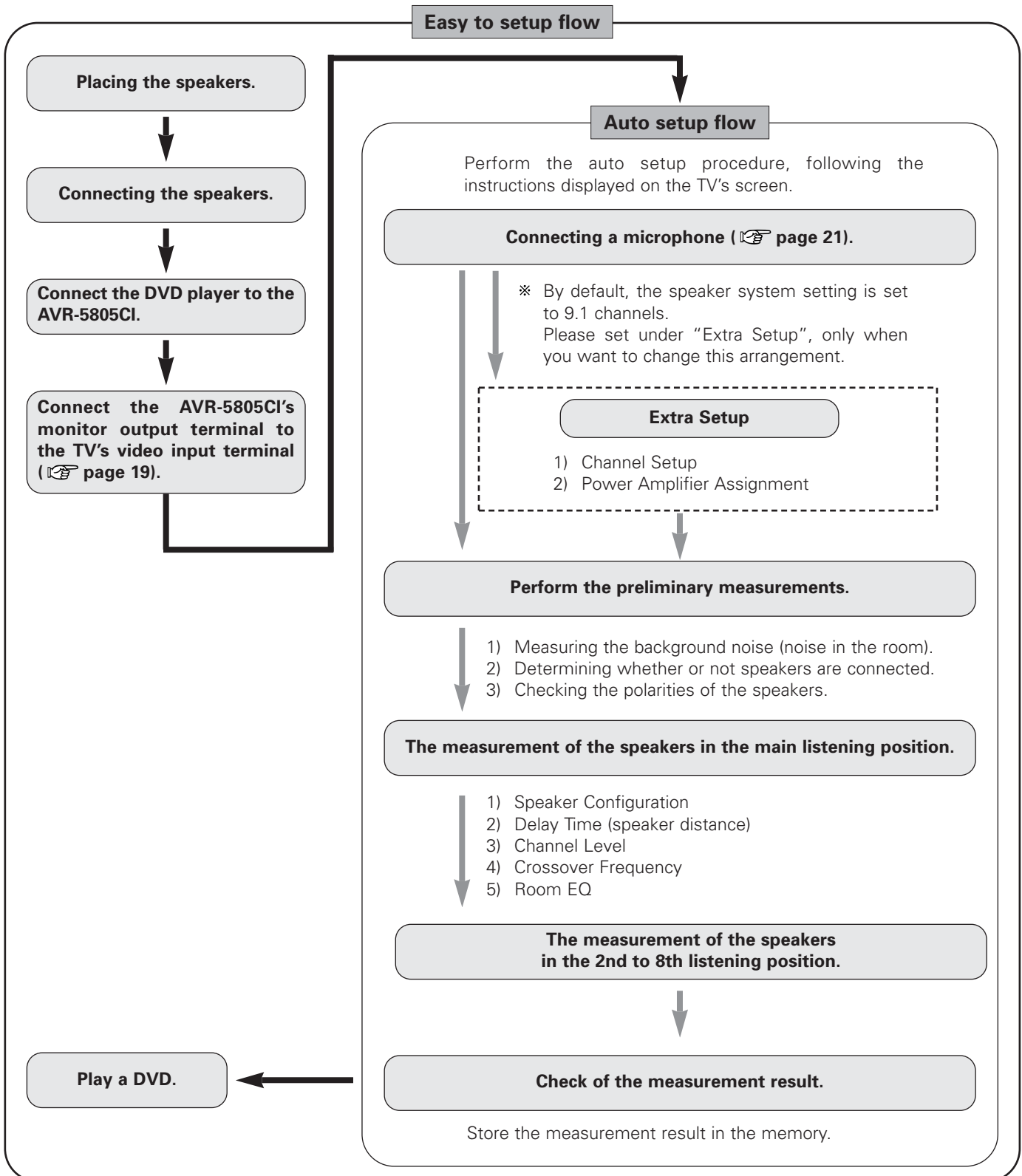

- Do not plug in the power supply cord until all connections have been completed.

Speaker system layout

■ **Basic system layout (For a THX Ultra2 system)**

- The following is an example of the basic layout for a system consisting of eight speaker systems and a television monitor:

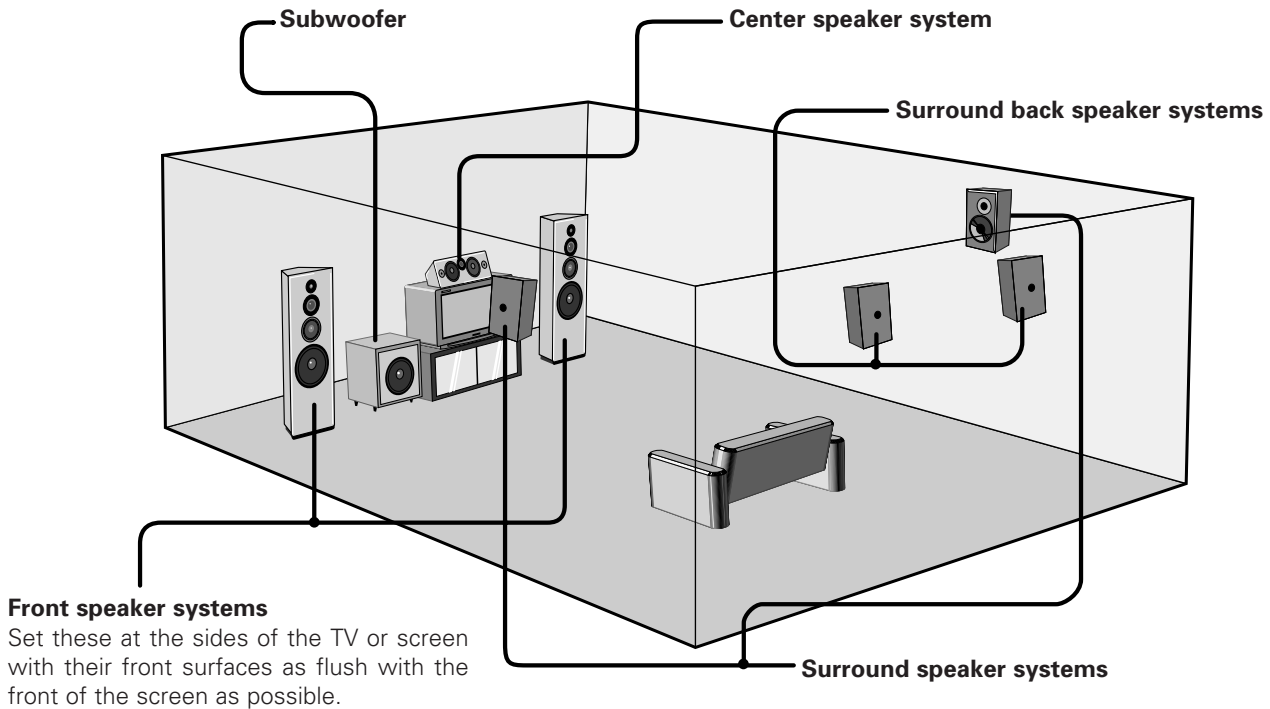

Two surround back speakers are required to use the THX Ultra2 Cinema, THX Music mode and THX Games mode. Set the surround back speakers so that the distance to the listening position is the same for both the left and right speakers. It is also recommended that the deviations of the distance from the listening position to L and R channel speakers (front left (FL) and front right (FR), surround left (SL) and surround right (SR), surround back left (SBL) and surround back right (SBR)) is less than 2 ft (60 cm).

With the AVR-5805CI it is also possible to use the surround speaker selector function to choose the best layout for a variety of sources and surround modes.

■ **Surround speaker selector function**

This function makes it possible to achieve the optimum sound fields for different sources by switching between two systems of surround speakers (A and B). The settings of the different speakers (A only, B only or A+B) are stored in the memory for the different surround modes, so they are set automatically when the surround mode is selected.

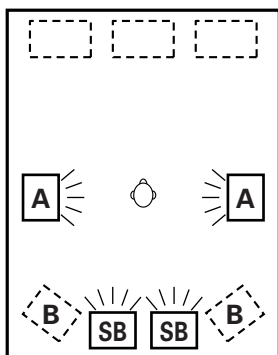

Using A only
(Multi surround speaker system)

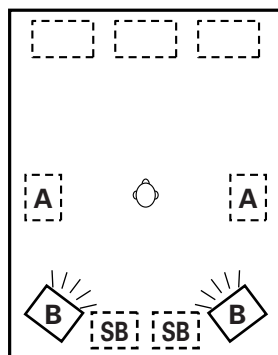

Using B only
(Single surround speaker system)

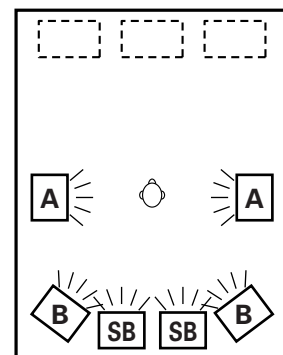

Using A and B

(SB: Surround Back Speakers)

Easy Setup and Operation

Speaker connections

- Connect the speaker terminals with the speakers making sure that like polarities are matched (⊕ with ⊕, ⊖ with ⊖). Mismatching of polarities will result in weak central sound, unclear orientation of the various instruments, and the sense of direction of the stereo being impaired.

NOTE:

- **NEVER touch the speaker terminals when the power is on. Doing so could result in electric shocks.**
- **When making connections, take care that none of the individual conductors of the speaker cable come in contact with adjacent terminals, with other speaker cable conductors, or with the rear panel and screws.**

■ Speaker Impedance

- Speakers with an impedance of from 6 to 16 Ω /ohms can be connected.

Connecting the speaker cables

1. Loosen by turning counterclockwise.

Either tightly twist or terminate the core wires.

2. Insert the cable.

3. Tighten by turning clockwise.

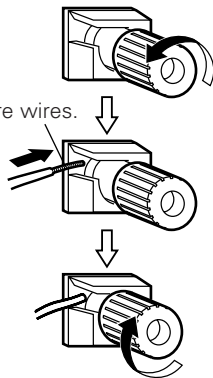

Connecting banana plugs

Turn clockwise to tighten, then insert the banana plug.

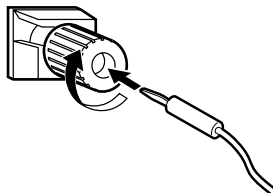

Protector circuit

This unit is equipped with a high-speed protection circuit. The purpose of this circuit is to protect the speakers under circumstances such as when the output of the power amplifier is inadvertently short-circuited and a large current flows, when the temperature surrounding the unit becomes unusually high, or when the unit is used at high output over a long period which results in an extreme temperature rise.

When the protection circuit is activated, the speaker output is cut off and the power supply indicator flashes. Should this occur, please follow these steps: be sure to switch off the power of this unit, check whether there are any faults with the wiring of the speaker cables or input cables, and wait for the unit to cool down if it is very hot. Improve the ventilation condition around the unit and switch the power back on.

If the protection circuit is activated again even though there are no problems with the wiring or the ventilation around the unit, switch off the power and contact a DENON service center.

Note on speaker impedance

The protector circuit may be activated if the set is played for long periods of time at high volumes when speakers with an impedance lower than the specified impedance (for example speakers with an impedance of lower than 4 Ω /ohms) are connected. If the protector circuit is activated, the speaker output is cut off. Turn off the set's power, wait for the set to cool down, improve the ventilation around the set, then turn the power back on.

Cooling fan

The AVR-5805CI is equipped with a cooling fan to prevent the temperature inside the set from rising. The fan is activated under certain usage conditions. It is temperature sensitive, to minimize or prevent audible fan noise.

Easy Setup and Operation

Connecting a DVD player and TV (Monitor)

- To connect the video output from the DVD player to the AVR-5805CI, you only need to choose one connection type. Component video connection offers the best quality (and is required for progressive DVD playback), followed by S-Video, while composite video offers the lowest picture quality of the three connection types. For more information about the video up conversion function (👉 page 28).
- The AVR-5805CI is equipped with HDMI terminals, so it can be connected to a DVD player or TV (monitor) using an HDMI cable. To connect it to a DVD player using a DVI-D cable (👉 page 37).
- The AVR-5805CI is equipped with a BNC terminal, so a DVD player or monitor can be connected using a BNC cable. If you choose to use the BNC connection, it needs to be assigned. For more information about Component Input Assignment (👉 page 112).
- To connect the digital audio output from the DVD player, you can choose from either the coaxial or optical connections. If you choose to use the optical connection, it needs to be assigned. For more information about Digital Input Assignment (👉 page 104).
- The AVR-5805CI is equipped with another set of input terminals for a non-DVD Video Disc Player (such as laser disc, VCD/SVCD, or future high definition disc player). The above connection guidelines for DVD also apply to the VDP input.

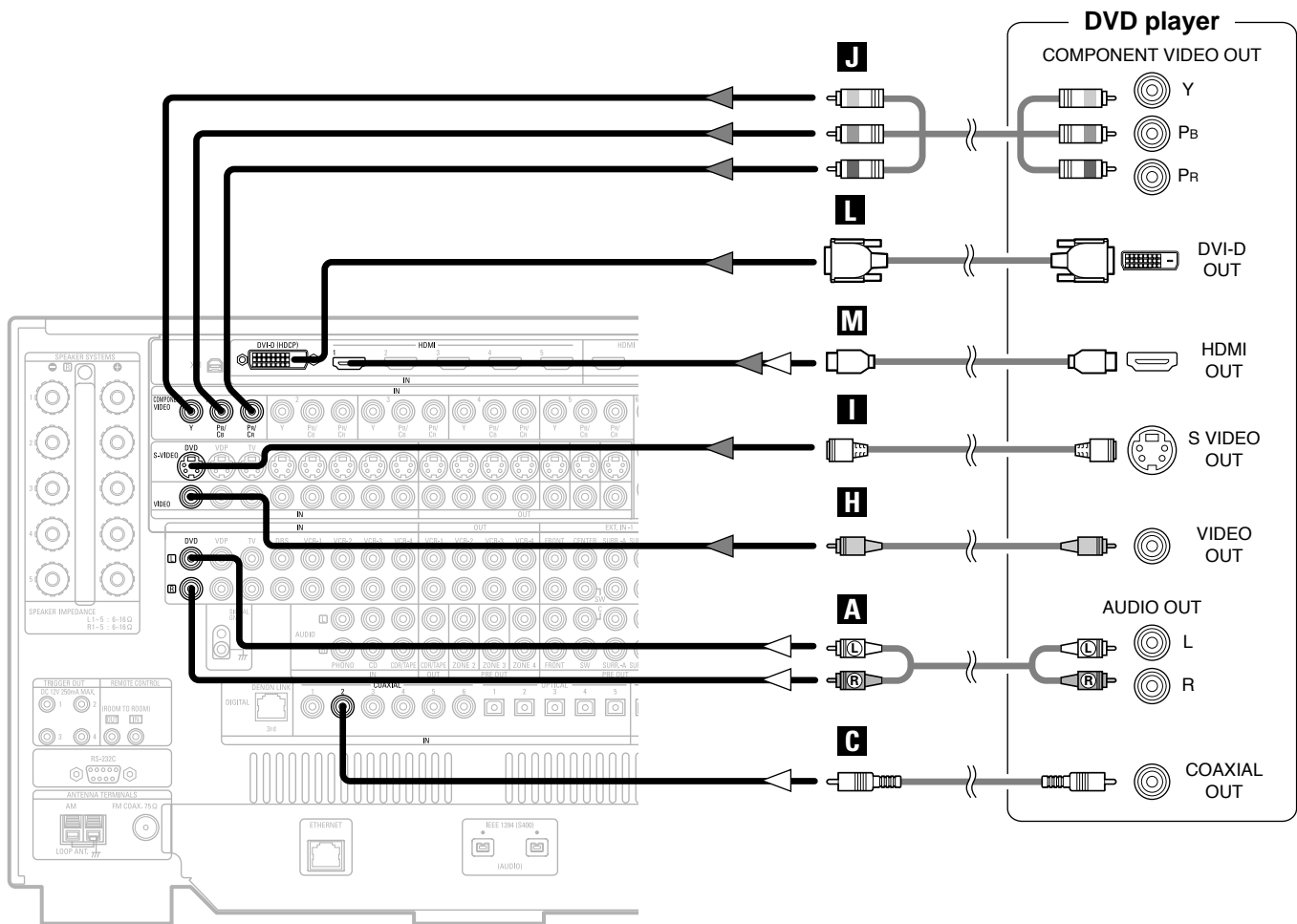

※ Audio signal flow is shown with white arrows, video signal flow is shown with gray arrows.

Easy Setup and Operation

- For best picture quality (especially with progressive DVD and other high definition sources) choose the component video or HDMI connection to your monitor or TV. S-Video and composite video outputs are also provided if your TV does not have component video inputs.

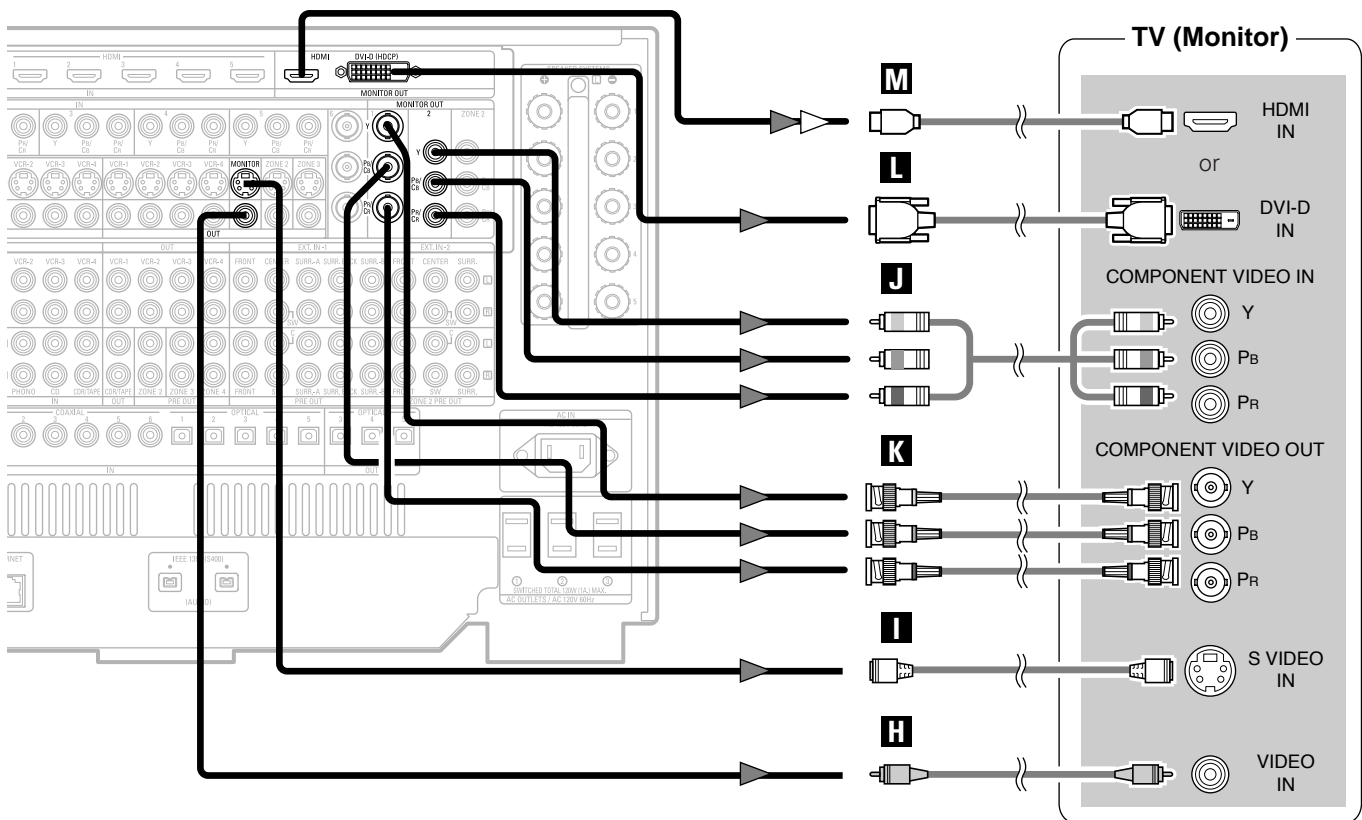

NOTE:

- The component video input and/or output terminals may be labeled differently on some TVs, monitors or video components (Y, Pb, Pr; Y, Cb, Cr; Y, B-Y, R-Y). Check the operating instructions for other components for further information.
- The COMPONENT MONITOR OUT-1 and the COMPONENT MONITOR OUT-2 can be used simultaneously. Connect with a BNC cable when using the COMPONENT MONITOR OUT-1 terminal, a component video cable when using the COMPONENT MONITOR OUT-2 terminal.
- The HDMI and DVI-D monitor output terminals on the AVR-5805CI can only be used one at a time, not simultaneously.
- Audio signals are only output from the HDMI monitor out connector when audio signals are input to the HDMI input connector.
- When connecting the AVR-5805CI and DVD player using an HDMI cable, also connect the AVR-5805CI and monitor or TV using an HDMI cable (see page 36).

Easy Setup and Operation

Turning on the power

1 Turn on your subwoofer.

- ※ Set the volume to halfway and set the crossover frequency to the maximum or Low pass filter off if your subwoofer can adjust the output volume and the crossover frequency.
- ※ Some subwoofers have a standby mode. Be sure to turn this function off before performing the Auto Setup procedure.

2 Turn on your TV (monitor).

3 Press the **POWER** switch.

■ ON:

The power turns on and the power indicator lights. Set the **POWER** switch to this position to turn the power on and off from the included remote control unit.

■ OFF:

The power turns off and indicator is off. In this position, the power cannot be turned on and off from the remote control unit.

4 Press the **ON/STANDBY** switch on the main unit or **ON** button on the remote control unit.

- When pressed, the power turns on and the display lights.
- When pressed again, the power turns off, the standby mode is set and the display turns off.
- ※ The sound is muted for several seconds, after which the unit operates normally.
- ※ Whenever the **ON/STANDBY** button is in the standby state, the apparatus is still connected to the AC line voltage. Please be sure to turn off the **POWER** switch or unplug the cord when you leave home for, say, a vacation.

5 Press the **AMP** button to select “AMP” (only when operating with the remote control unit).

Starting Auto Setup

1 Press the **SYSTEM SETUP** button.

- The “System Setup Menu” appears.

```
System Setup Menu
1. Auto Setup/Room EQ
2. Speaker Setup
3. Audio Input Setup
4. Video Setup
5. Advanced Playback
6. Zone Setup
7. Option Setup
Exit
```

2 Press the **CURSOR** Δ or ∇ button to select “Auto Setup / Room EQ”, then press the **ENTER** button.

- The “Auto Setup / Room EQ” menu appears.

```
1. Auto Setup/Room EQ
1. Auto Setup
2. Room EQ Setup
3. Direct Mode Setup
4. Mic Input Select
Exit
```

3 Press the **CURSOR** Δ or ∇ button to select “Auto Setup”, then press the **ENTER** button.

- The “Auto Setup” screen appears.

```
1-1. Auto Setup
Please place microphone
at ear height at
main listening position.
Extra Setup ◀
Channel: 9. 1CH
Start ◀
Cancel ◀
```

- ※ The message “Connect Microphone” is displayed if no microphone is connected. If so, connect the auto setup microphone.



- If no operation is performed for approximately 3 minutes during the auto setup procedure, the screensaver is launched. The screensaver is canceled if any one of the **CURSOR**, **ENTER** or **SYSTEM SETUP** button is pressed.

Extra Setup

- The AVR-5805CI has ten available amplifier channels, some of which can be assigned for powering speakers in ZONE2, ZONE3 and ZONE4 depending on the speaker system complement in the main room. If this functionality is not needed, skip this “Extra Setup” procedure and proceed to “Preliminary Measurements”.
- By default, the speaker system setting is set to 9.1 channels.

1 Press the **CURSOR** Δ or ∇ button to select “Extra Setup”, then press the **CURSOR** \triangleleft button.

- Switch to the “Extra Setup” screen.

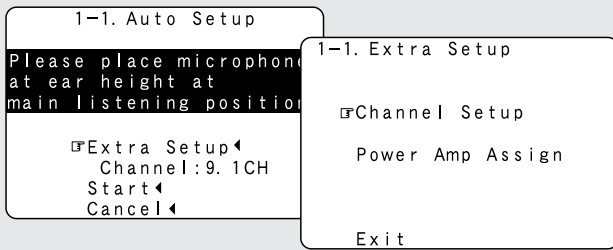

2 Press the **CURSOR** Δ or ∇ button to choose the setting you want to change, then press the **ENTER** button.

- Switch to the setting screen.

- ※ For instructions on making the “Channel Setup” settings (page 126 ~128).
- ※ For instructions on making the “Power Amp Assign” settings (page 129 ~ 133).
- ※ The speakers measured with this Auto Setup procedure are based on the setting of these “Channel Setup” and “Power Amp Assign” functions.

3 Once the settings are completed, press the **ENTER** button at the each setting screen.

- The “Extra Setup” screen reappears.

4 Press the **CURSOR** Δ or ∇ button to select “Exit”, then press the **ENTER** button.

- Return to the “Auto Setup” screen.

Preliminary measurements

- This procedure is used to automatically determine the background noise, whether or not speakers are connected, and the polarities of the connected speakers.
- To avoid affecting the measurements, turn off the air-conditioner or any other device that makes noise and take the measurements with the room as quiet as possible.

1 Press the **CURSOR** Δ or ∇ button to select “Start”, then press the **CURSOR** \triangleleft button.

- Start the preliminary measurements.

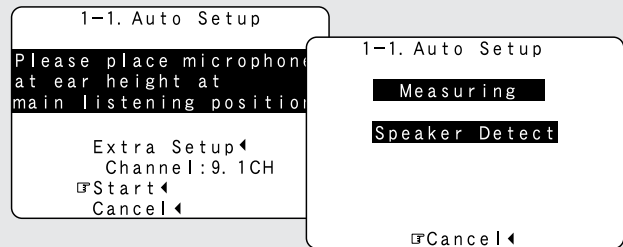

- ※ The screen shown at the below appears once the preliminary measurements are completed.



2 Press the **ENTER** button.

- Switch to the “Speaker Detect Check” screen.

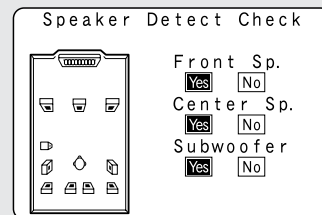

[First screen]

3 Check the results of the speaker detection, then press the **ENTER** button.

- Switch to the second screen.

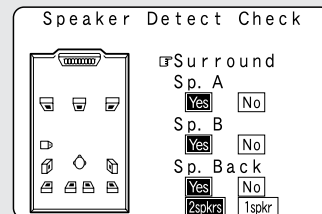

[Second screen]

4 If the check ends, press the **ENTER** button again.

Easy Setup and Operation

NOTE:

- If the results are not as expected or if an error message is displayed, select “Retry” and perform the measurements again. (For details on the error messages (👉 page 26).) If the results of remeasurement are still not as expected or if an error message is displayed, turn off the power switch and check the speaker connections. Then start the measurements again from the beginning.
- Measurement is cancelled when **MASTER VOLUME** is operated while the Auto Setup is performed.

Speaker system measurement

- With these measurements, the “Speaker Configuration”, “Delay Time”, “Channel Level”, “Crossover Frequency” and “Room EQ” are analyzed automatically. The main listening position is measured first, so leave the microphone where it is.

1 Press the CURSOR Δ or ∇ button to select “OK Start”, then press the CURSOR \triangleleft button.

- Measurements for the first point start.

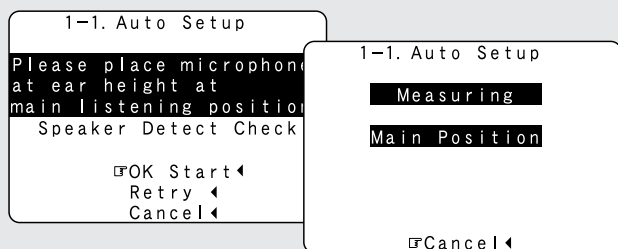

- ※ The screen shown at the below appears once the measurements for the main listening position are completed.

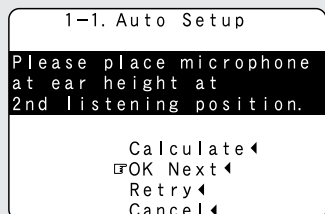

2 Next the measurements for the second point will be taken.

- ※ Place the microphone at the second listening position. For instructions on the position in which the microphone should be placed (👉 page 20).

3 Press the CURSOR \triangleleft button.

- Measurements for the second point start.

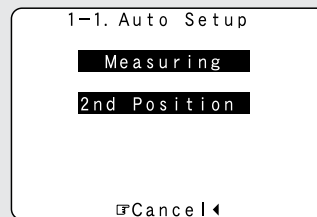

4 Perform step 2, 3 repeatedly.

- ※ The more measurement points, the better the resulting room correction effect. We recommend a minimum of 6 measurement points – 8 measurement points provides the best room correction effect.

5 After measuring at the number of points according to your listening environment, press the CURSOR Δ or ∇ button to select “Calculate”, then press the CURSOR \triangleleft button.

- The speaker system is analyzed.

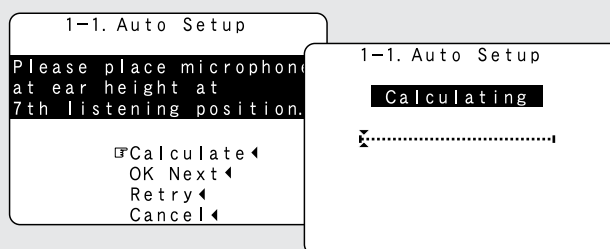

- ※ The amount of time required for the analysis depends on the number of speakers and the number of measuring points. The greater the number of speakers and measuring points, the longer the time required. For example, for ten speaker systems and 6 measuring points, the calculations require approximately 6 minutes.
- ※ Measurements can be ended when there are 5 or less measurement locations; however, to obtain better results, measurements at **6 or more locations** is recommended.
- ※ Once the calculations are completed, a screen for confirming the results of the measurements appears.

Check of the measurement result

- The results of the measured items can be checked.

1 Press the CURSOR Δ or ∇ button to select items, then press the ENTER button.

- Switch to the verification screen.

Example: Speaker Config. Check

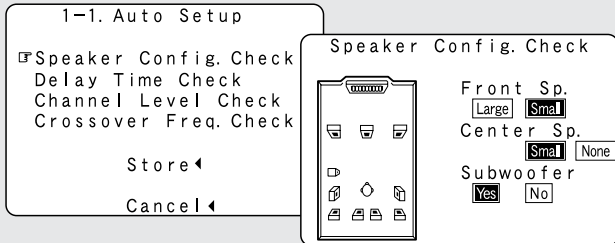

[First screen]

2 Press the ENTER button.

- Switch to the second screen.

Example: Speaker Config. Check

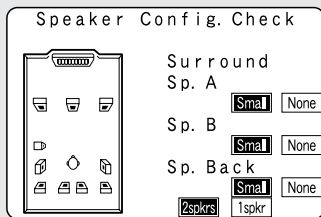

[Second screen]

3 If the check ends, press the ENTER button again.

4 Press the CURSOR Δ or ∇ button to select whether or not to save the data you have checked.

Store:

Set with the checked measurement value.
All parameters are stored up.

Cancel:

Cancel the auto setup settings.

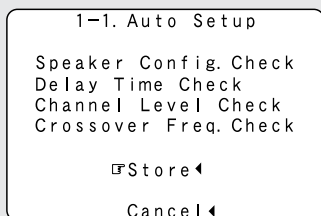

5 Press the CURSOR \triangleleft button.

- After the data is stored, the "Auto Setup / Room EQ" menu appears automatically.

- Sometimes due to the electrical complexities of subwoofers and the interaction with the room, THX recommends setting the level and the distance of the subwoofer manually.
- Sometimes due to interaction with the room, you may notice irregular results when setting the level and/or distance of the main speakers. If this happens, THX recommends setting them manually.
- Please note that any THX main speakers should be set to Small (80 Hz). If you set up your speakers using Auto Setup, please make sure manually that any THX speakers are set to Small with 80 Hz crossover.



- When measurements have been made using the measurement microphone, speakers with a built-in filter such as subwoofers might be set with a value that differs from the physical distance because of the internal electrical delay.
- If the "Channel Setup" or "Power Amplifier Assignment" settings are changed after completing the auto setup, perform the auto setup procedure again. In the same way, if the speaker layout has been changed, we recommended performing the auto setup procedure over again.

NOTE:



- Do not turn off the power while the data is being stored. If the power is turned off while the data is being stored, the Room EQ parameters stored in the memory will be cleared, and it will not be possible to select "Audyssey", "Front" or "Flat" equalizer settings.



Easy Setup and Operation

About the error message

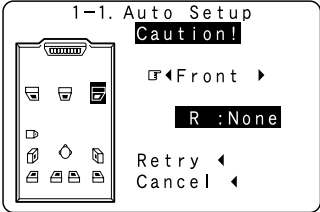
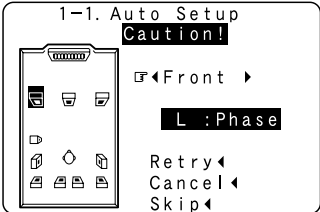
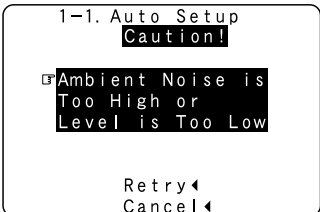
- These error messages will be displayed when performing the measurements of Auto Setup and the automatic measurements can not be completed because of the speaker arrangement, measurement environment, or other factors. Please check the following matters, reset the pertinent items, and measure again. Be sure to turn off the AVR-5805CI's power before checking the speaker connections.

Screen example	Cause	Measures
	<p>① The speakers required for producing suitable reproduction have not been detected.</p> <ul style="list-style-type: none"> • The front L speaker was detected, but the front R speaker was not detected. • Only one channel of the surround (A) and surround (B) speakers was detected. • Sound was output from the R channel when only one surround back speaker was connected. • The surround back or the surround (B) speaker was detected, but the surround (A) speaker was not detected. <p>※ If multiple errors occur, press the CURSOR ◀ or ▶ button to check the contents.</p>	<ul style="list-style-type: none"> • Check that the pertinent speakers are properly connected.
	<p>② The speaker polarity is connected in reverse.</p> <p>※ If multiple errors occur, press the CURSOR ◀ or ▶ button to check the contents.</p>	<ul style="list-style-type: none"> • Check the polarity of the pertinent speakers. • For some speakers, the screen below may be displayed even though the speakers are properly connected. If so, select "Skip◀".
	<p>③ There is too much ambient noise in the room and the measurements cannot be made accurately.</p> <p>④ The sound level that is output from the speakers and/or subwoofer is too low.</p>	<ul style="list-style-type: none"> • Either turn off the power of the device that generated the noise during the measurements or move the device away. • Try again at a time when it is quieter. • Check the placement and orientation of the loudspeakers. • Adjust the subwoofer's output level.
	<p>⑤ The measurement microphone is not connected, or all of speakers have not been detected.</p> <p>⑥ The front L speaker was not detected.</p>	<ul style="list-style-type: none"> • Connect the measurement microphone to the SETUP MIC jack. • Check the speaker connection.

Connecting Other Sources

Cable indications

- The hookup diagrams on the subsequent pages assume the use of the following optional connection cables (not supplied).

Audio cable	Video cable
<p>A Analog connections (Stereo)</p> <p>(White) </p> <p>(Red) </p> <p style="text-align: center;">Pin-plug cable</p> <p>B Analog connections (Monaural, for subwoofer)</p> <p> </p> <p style="text-align: center;">Pin-plug cable</p> <p>C Digital connections (Coaxial)</p> <p>(Orange) </p> <p style="text-align: center;">Coaxial cable (75 Ω/ohms pin-plug cable)</p> <p>D Digital connections (Optical)</p> <p> </p> <p style="text-align: center;">Optical cable (Optical fiber cable)</p> <p>E DENON LINK connections</p> <p> </p> <p style="text-align: center;">DENON LINK cable</p> <p>F IEEE1394 connections</p> <p> </p> <p style="text-align: center;">4-pin, S400 IEEE1394 cable</p> <p>G Speaker connections</p> <p> </p> <p style="text-align: center;">Speaker cable</p>	<p>H Video connections</p> <p>(Yellow) </p> <p style="text-align: center;">Video cable (75 Ω/ohms video pin-plug cable)</p> <p>I S-Video connections</p> <p> </p> <p style="text-align: center;">S-Video cable</p> <p>J Component video connections</p> <p>(Green) (Y)</p> <p>(Blue) (PB/CB)</p> <p>(Red) (PR/CR)</p> <p style="text-align: center;">Component video cable</p> <p>K Component video connections</p> <p>(Y) (Y)</p> <p>(PB/CB) (PB/CB)</p> <p>(PR/CR) (PR/CR)</p> <p style="text-align: center;">BNC (75 Ω/ohms) cable</p> <p>L DVI-D connections</p> <p> </p> <p style="text-align: center;">24-pin DVI-D cable</p>
Audio and Video cable	
<p>M HDMI connections</p> <p> </p> <p style="text-align: center;">19-pin HDMI cable</p>	
Signal direction	
<p>Audio signal</p> <p> IN OUT OUT IN</p>	<p>Video signal</p> <p> IN OUT OUT IN</p>

NOTE:

- Do not plug in the power supply cord until all connections have been completed.
- When making connections, also refer to the operating instructions of the other components.
- Be sure to connect the left and right channels properly (left with left, right with right).
- Note that binding pin-plug cables together with power supply cords or placing them near a power transformer will result in generating hum or other noise.

NOTE:

• Connecting a LD (laser disc) player with a Dolby Digital RF Output

The AVR-5805CI does not have a DD RF demodulator function. Therefore, you need to use a commercially available outboard DD RF demodulator and connect its digital output to one of the AVR-5805CI available digital inputs. Refer to the demodulator's operating instruction for further information.

Connecting Other Sources

The video conversion function

- The AVR-5805CI is equipped with a function for up and down converting video signals.

Because of this, the AVR-5805CI's MONITOR OUT terminal can be connected to the monitor (TV) with a set of cables offering a higher quality connection, regardless of how the player and the AVR-5805CI's video input terminals are connected.

Generally speaking, analog video connections using the component video terminals offer the highest quality playback, followed by connections using the S-Video terminals, then connections using the regular video terminals (yellow).

The flow of the video signals.

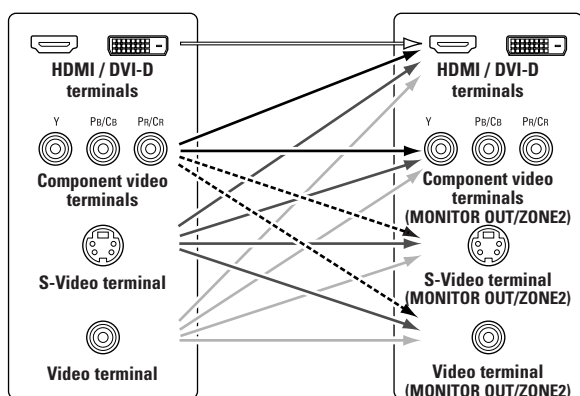

AVR-5805CI's input terminals

AVR-5805CI's output terminals

----- : only MAIN ZONE 480i/576i

Cautions on the ZONE2 video conversion function:

- There is no TBC (Time Base Collector) for ZONE2.

When the component video terminals are used to connect the AVR-5805CI with a TV (or monitor, projector, etc.) and the video (yellow) or S-Video terminals are used to connect the AVR-5805CI with a VCR, depending on the combination of the TV and VCR the picture may flicker in the horizontal direction, be distorted, be out of sync or not display at all when playing video tapes.

If this happens, connect a commercially available video stabilizer, etc., with a TBC (time base corrector) function between the AVR-5805CI and the VCR, or if your VCR has a TBC function, turn it on.

NOTE:

- It is not possible to down-convert from HDMI and DVI-D input signals to the component, S-Video or composite video monitor output terminals.
- Video down conversion to the MAIN ZONE's monitor output is only possible when the component video input resolution is 480i (interlaced standard definition video – NTSC format, for North America) or 576i (interlaced standard definition video – PAL format, for Europe and other countries).
- It is not possible to down-convert from the ZONE2's component video signal to a S-Video or composite signal, so when not using the ZONE2's component monitor output terminal, use an S-Video connection cable or composite connection cable to connect the AVR-5805CI with the player.
- To set the video conversion function for the MAIN ZONE to "OFF" (☞ page 112).
- Set the resolution of the video output to one that is compatible with the resolution of your monitor.
- When "Component" is set at "Scaler" under "HDMI/Component Out", the signals are output to the HDMI/DVI-D monitor output terminal with their original resolution. Use a monitor compatible with a resolution of 480i/576i.

■ The analog video to HDMI conversion function:

The AVR-5805CI's video up-conversion function lets you output analog video input signals (component – 480i/576i, 480p/576p, 1080i or 720p; S-Video and composite video - 480i/576i) to the HDMI monitor output terminal.

- With the AVR-5805CI, the resolution of the signal output to the HDMI MONITOR OUT terminal can be selected (☞ page 113, 114). The resolutions with which the monitor is compatible can be checked using the **STATUS** button on the main unit or the **ON SCREEN** button on the remote control unit.
- The resolution of the signal output to the component monitor output terminal can be set on the AVR-5805CI.



- If you do not want to use the function for converting analog video signals to HDMI signals, select "OFF" for "Analog to HDMI Convert" at "Setting the HDMI/Component Out Setup" (☞ page 113, 114).

In this case, the function for video up conversion to the component video terminal operates.

On screen display for component video outputs and HDMI output

- When viewing component video signals or HDMI signals via the AVR-5805CI, the on screen display is displayed on the monitor when the "System Setup" operations are performed and when the remote control unit's **ON SCREEN** button is operated.
- To view the on screen display using an HDMI monitor, set "Analog to HDMI Convert" at "HDMI/Component Out" to "ON" (default).
- When only component video signals are input to the AVR-5805CI, the characters of the on screen display are not displayed over the picture.

Connecting equipment with HDMI terminals [To convert analog video signals to HDMI signals]

- The AVR-5805CI is equipped with a function for converting analog video signals into HDMI signals. You can do this by either a component or a video or a S-Video connection.
- Audio signals are not output from the HDMI monitor output terminal, so also make analog or digital audio connections. To play sound using digital audio connections, assign the digital terminal (coaxial or optical) at "Setting the Digital In Assignment" (page 104).

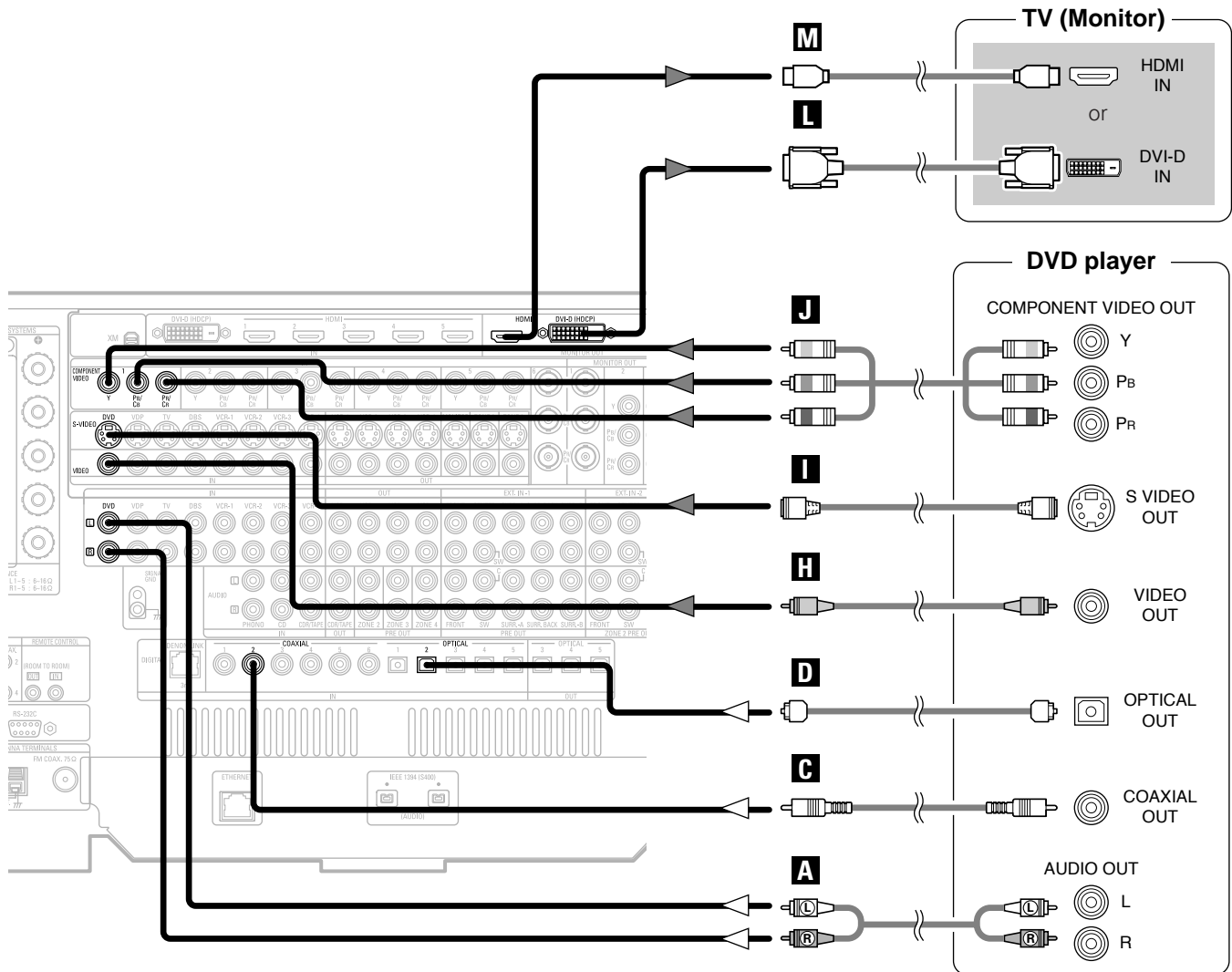

NOTE:

- When "Through" is set at "Resolution" under "Setting the HDMI/Component Out Setup", use a monitor compatible with input resolutions of 480i/576i.
- If your monitor is not equipped with an HDMI terminal, connect the AVR-5805CI to the monitor using the component video, S-Video, or composite video terminals.



Connecting Other Sources

Connecting a TV tuner

- For best picture quality choose the component video connection to your TV tuner. S-Video and composite video outputs are also provided if your TV tuner does not have component video inputs.
- To connect the digital audio output from the TV tuner, you can choose from either the coaxial or optical connections. If you choose to use the optical connection, it needs to be assigned. For more information about Digital Input Assignment (page 104).

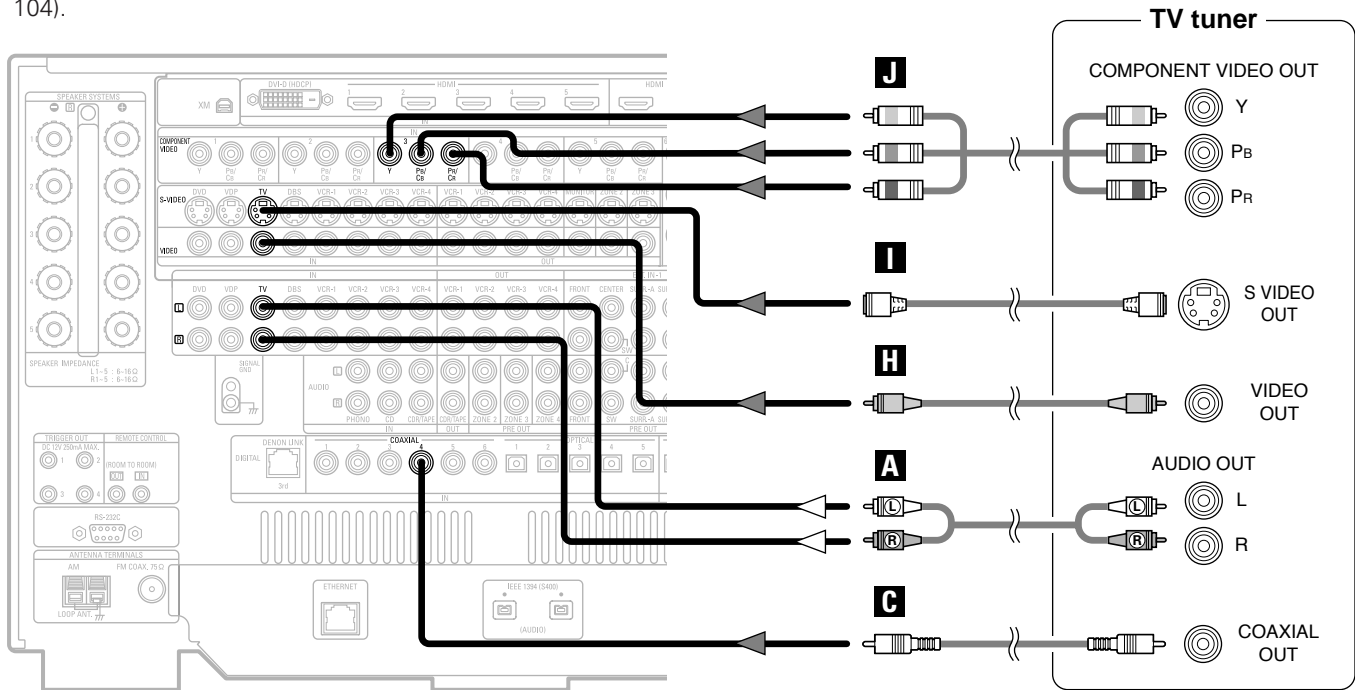

Connecting a DBS tuner

- For best picture quality choose the component video connection to your DBS tuner. S-Video and composite video outputs are also provided if your DBS tuner does not have component video inputs.
- To connect the digital audio output from the DBS tuner, you can choose from either the coaxial or optical connections. If you choose to use the optical connection, it needs to be assigned. For more information about Digital Input Assignment (page 104).

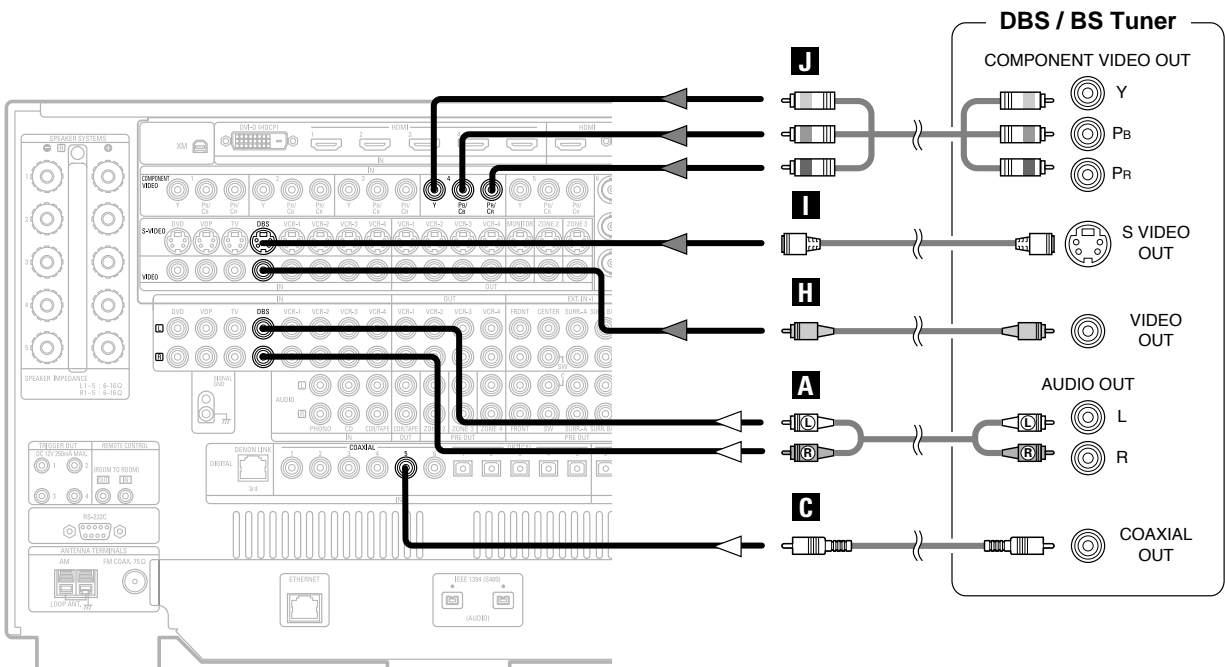

Connecting the external inputs (EXT. IN) terminals

- AVR-5805CI is equipped with two analog external input terminals for 9.1 channels and 5.1 channels.
- These terminals are for inputting multi-channel audio signals from an outboard decoder, or a component with a different type of multi-channel decoder, such as a DVD-Audio player, or a multi-channel Super Audio CD player, or other future multi-channel sound format decoder.
- The method of video signal connection is the same as that for DVD player (👉 page 18).
- For instructions on playback using the external input (EXT. IN) terminals (👉 page 47) and “Setting the EXT. IN Setup” (👉 page 105).

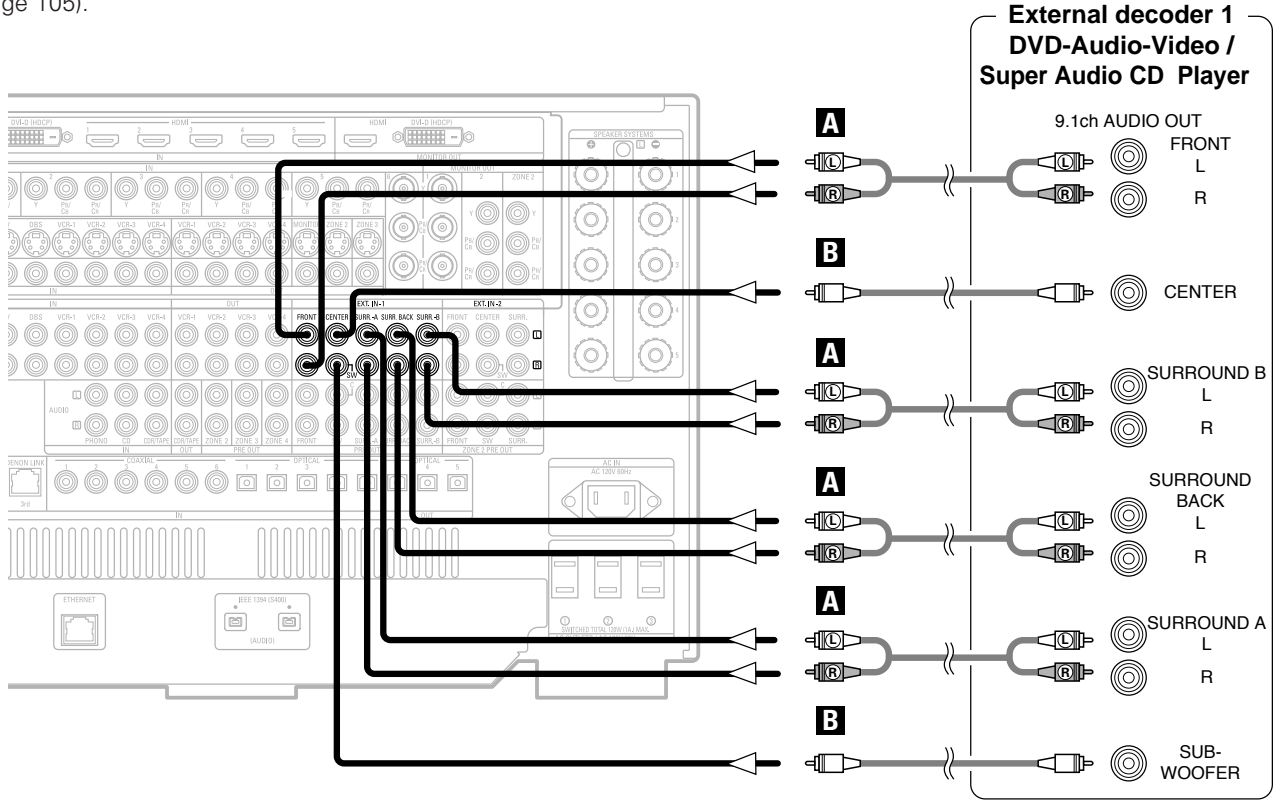

- The EXT. IN-2 terminal can be connected for 5.1-channels (FL, FR, C, SL, SR and SW) in the same way as the EXT. IN-1 terminal.
- With discs on which special copyright protection measures have been taken, however, the digital signals may not be output from the DVD player. In this case, connect the DVD player’s analog multi-channel output to the AVR-5805CI’s EXT. IN terminals for playback. Also refer to your DVD player’s operating instructions.

Connecting a video camera or video game

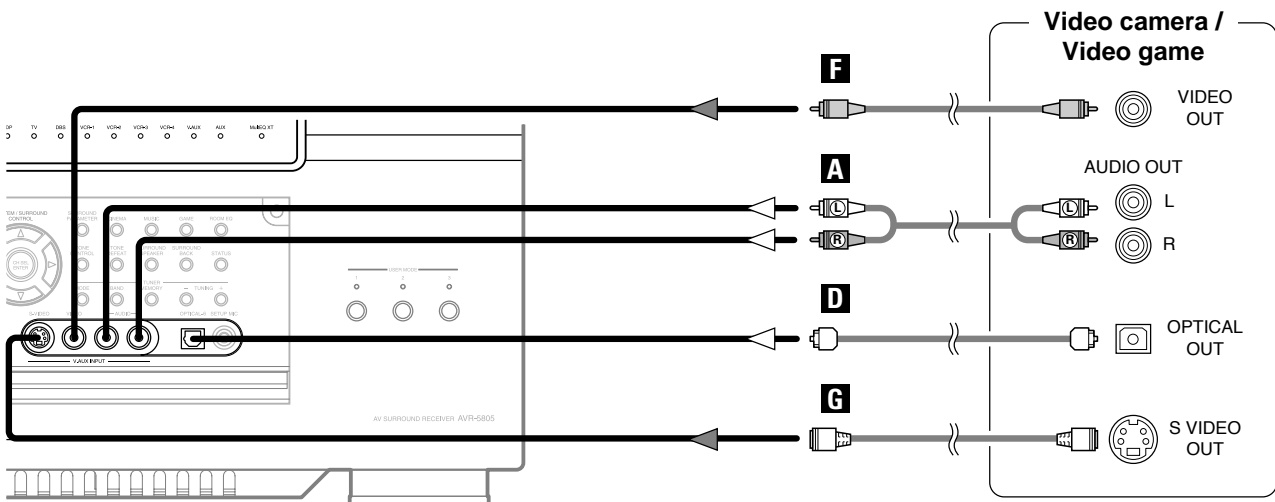

Connecting Other Sources

Connecting a DVD recorder

- For best picture quality choose the component video connection to your DVD recorder. S-Video and composite video outputs are also provided. If you choose to use the component video or BNC connection, it needs to be assigned. For more information about Component Input Assignment (page 112).
- If you wish to perform analog dubbing from a digital sources, such as a DVD recorder to an analog recorder such as a cassette deck, you will need to connect analog inputs and outputs as shown below, in addition to the digital audio connections.
- To connect the digital audio output from the DVD recorder, you can choose from either the coaxial or the optical connections. If you choose to use the coaxial connection, it needs to be assigned. For more information about Digital Input Assignment (page 104).

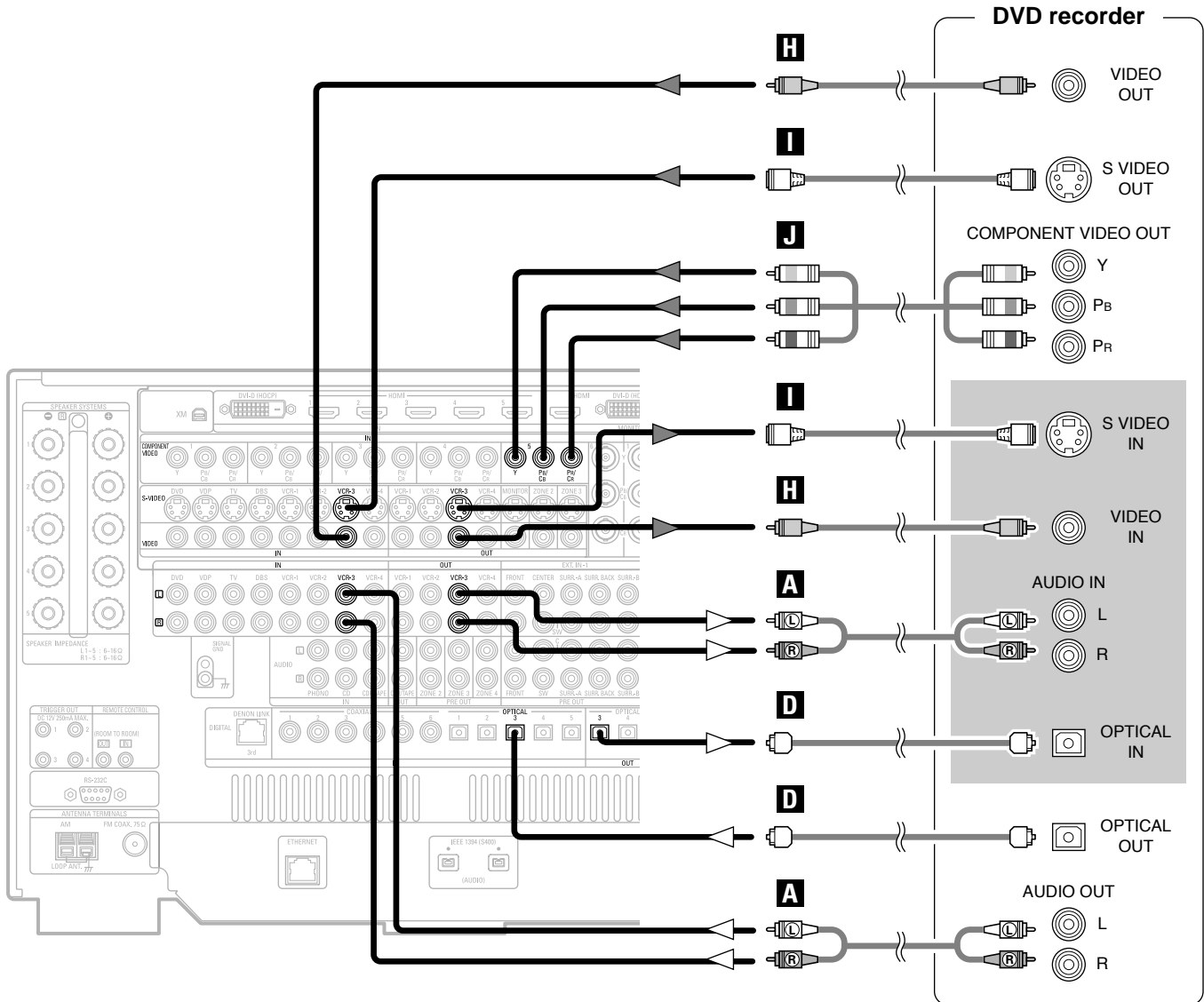

NOTE:

- When recording to DVD recorder, it is necessary that the type of cable used with the playback source equipment be the same type that is connected to the AVR-5805CI VCR-1 (to 4) OUT terminal.

Example: TV IN → S-Video cable : VCR-1 to 4 OUT → S-Video cable
 TV IN → Video cable : VCR-1 to 4 OUT → Video cable

- Do not connect the output of the component connected to the OPTICAL 3 (to 5) OUT terminal on the AVR-5805CI's rear panel to any terminal other than the OPTICAL 3 (to 5) IN terminal.

Connecting a VCR

- There are three sets of video deck (VCR) terminals, so three video decks can be connected for simultaneous recording or video copying.
- If you choose to use the component video connection, it needs to be assigned. For more information about Component Input Assignment (page 112).

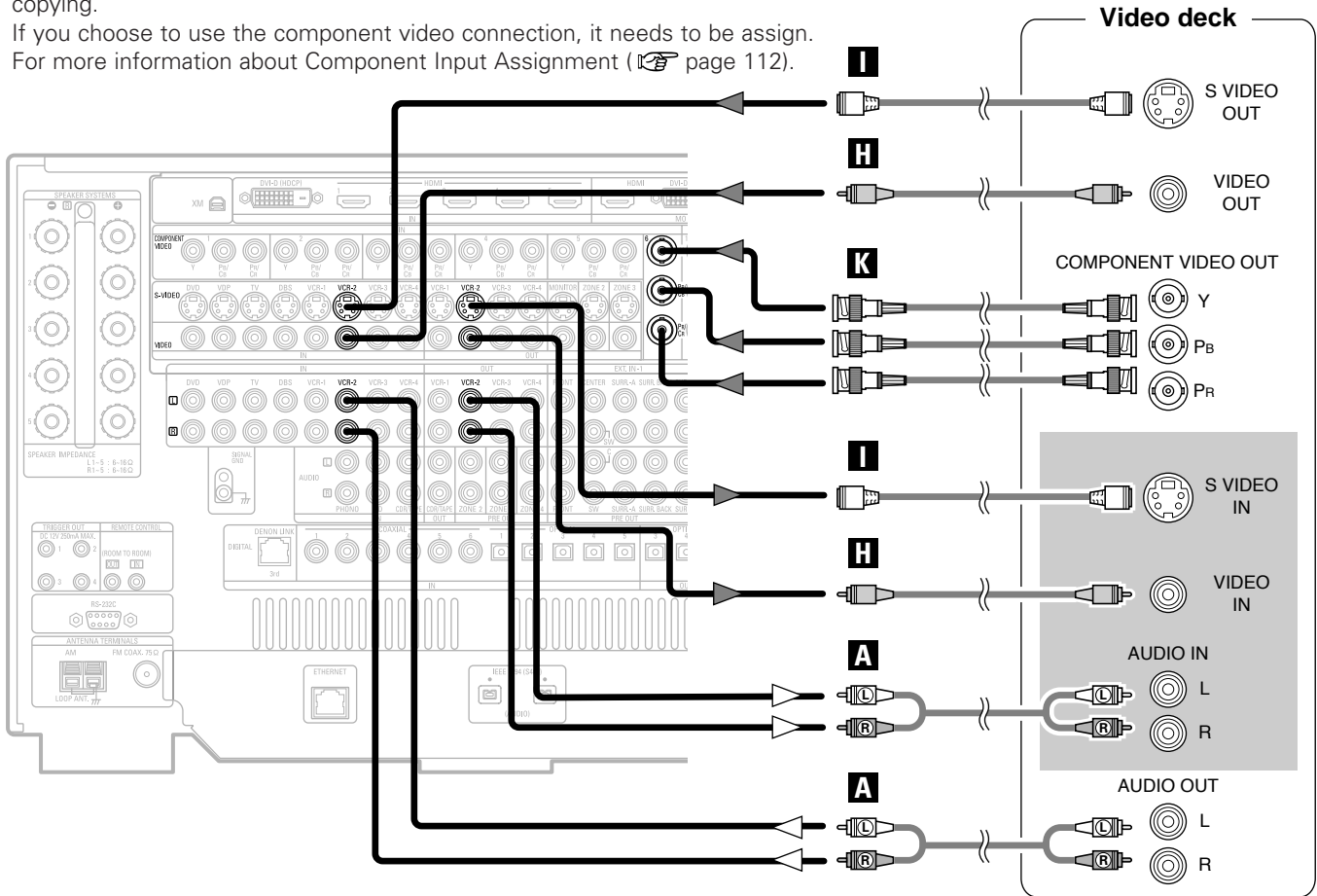

NOTE:

- When recording to VCR, it is necessary that the type of cable used with the playback source equipment be the same type that is connected to the AVR-5805CI VCR-1 (to 4) OUT terminal.
Example: VCR-1 IN → S-Video cable : VCR-2 OUT→ S-Video cable
 VCR-2 IN → Video cable : VCR-1 OUT→ Video cable

Connecting a CD player

- To connect the digital audio output from the CD player, you can choose from either the coaxial or optical connections. If you choose to use the optical connection, it needs to be assigned. For more information about Digital Input Assignment (page 104).

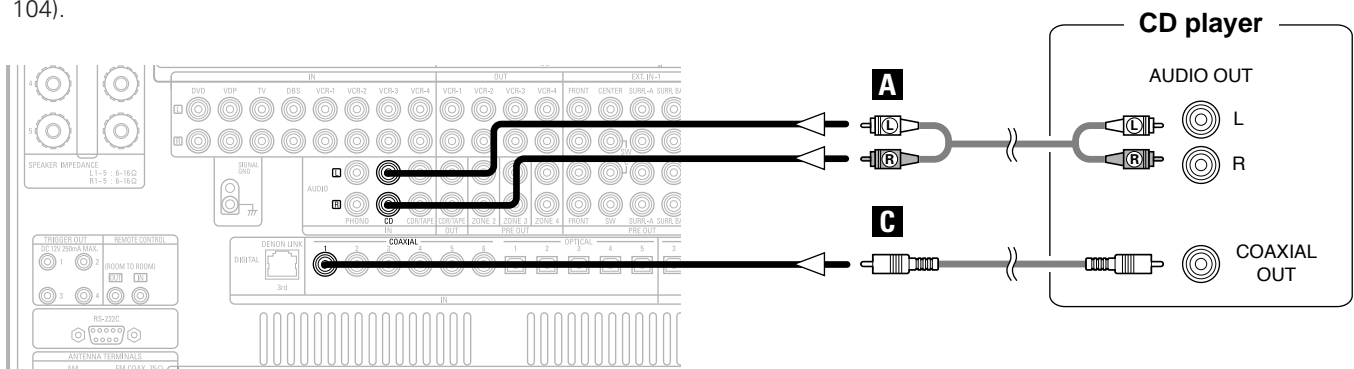

Connecting Other Sources

Connecting a turntable

- You can connect the turntable (MM cartridge) to the PHONO terminals.

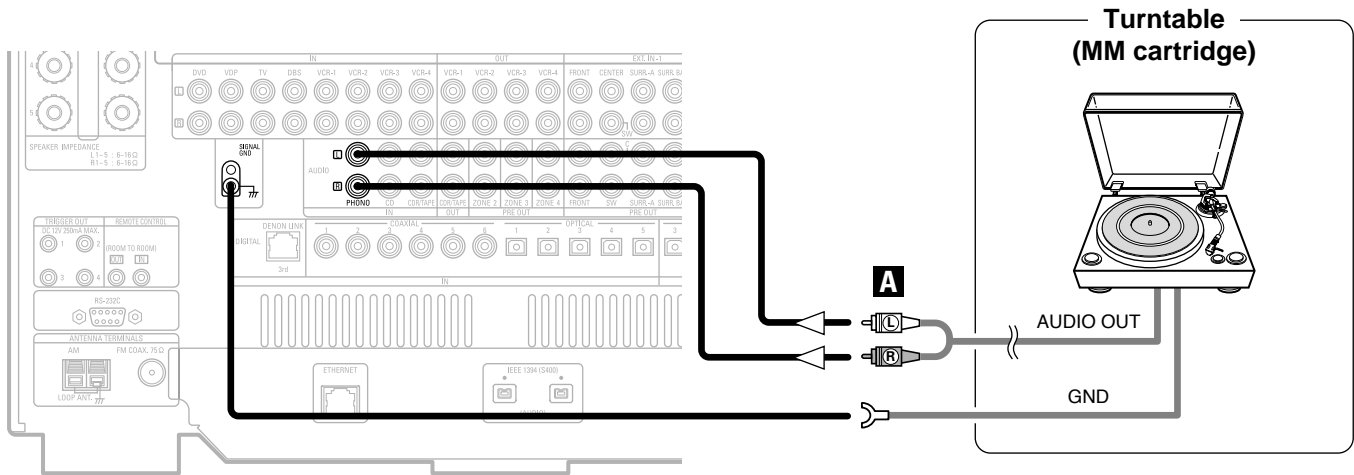

NOTE:

- The phono input can accept signals from moving magnet (MM) and high output moving coil (MC) phono cartridges. If your turntable is equipped with a low output MC cartridge, you will need to use a separate MC head amplifier or step-up MC transformer.
- If humming or other noise is generated when the ground wire is connected to the SIGNAL GND terminal, disconnect the ground wire.

Connecting a CD recorder or MD recorder

- If you wish to perform analog dubbing from a digital source, such as a CD or MD recorder to an analog recorder such as a cassette deck, you will need to connect analog inputs and outputs as shown below, in addition to the digital audio connections.

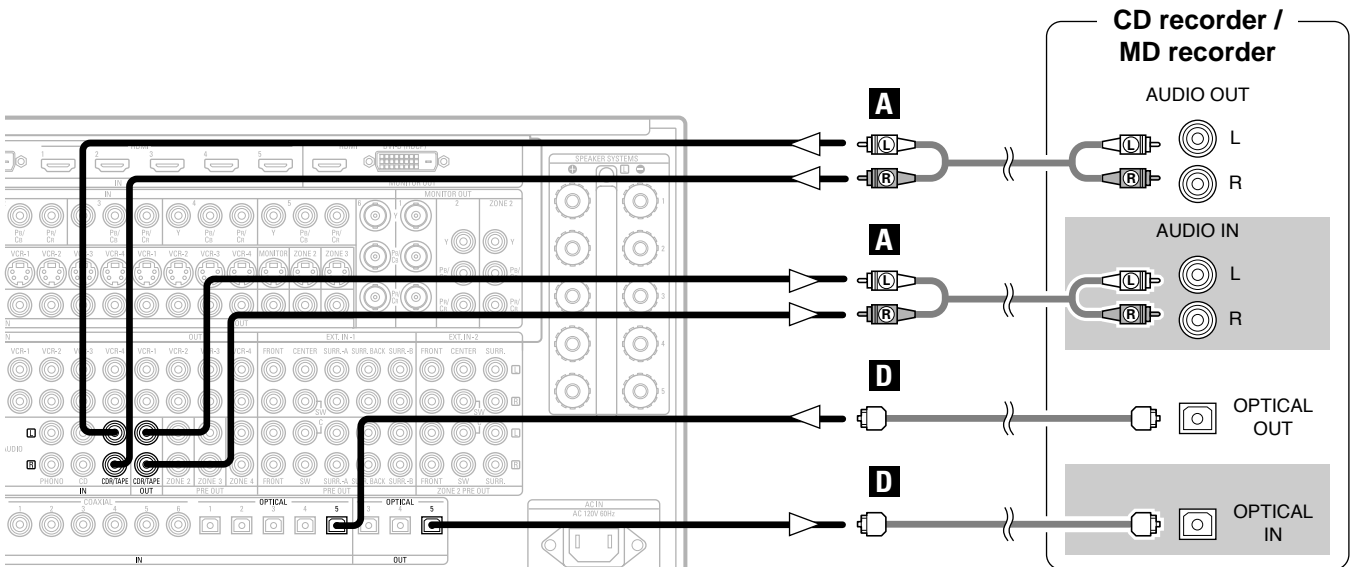

NOTE:

- Do not connect the output of the component connected to the OPTICAL 5 OUT terminal on the AVR-5805CI's rear panel to any terminal other than the OPTICAL 5 IN terminal.

Connecting a tape deck

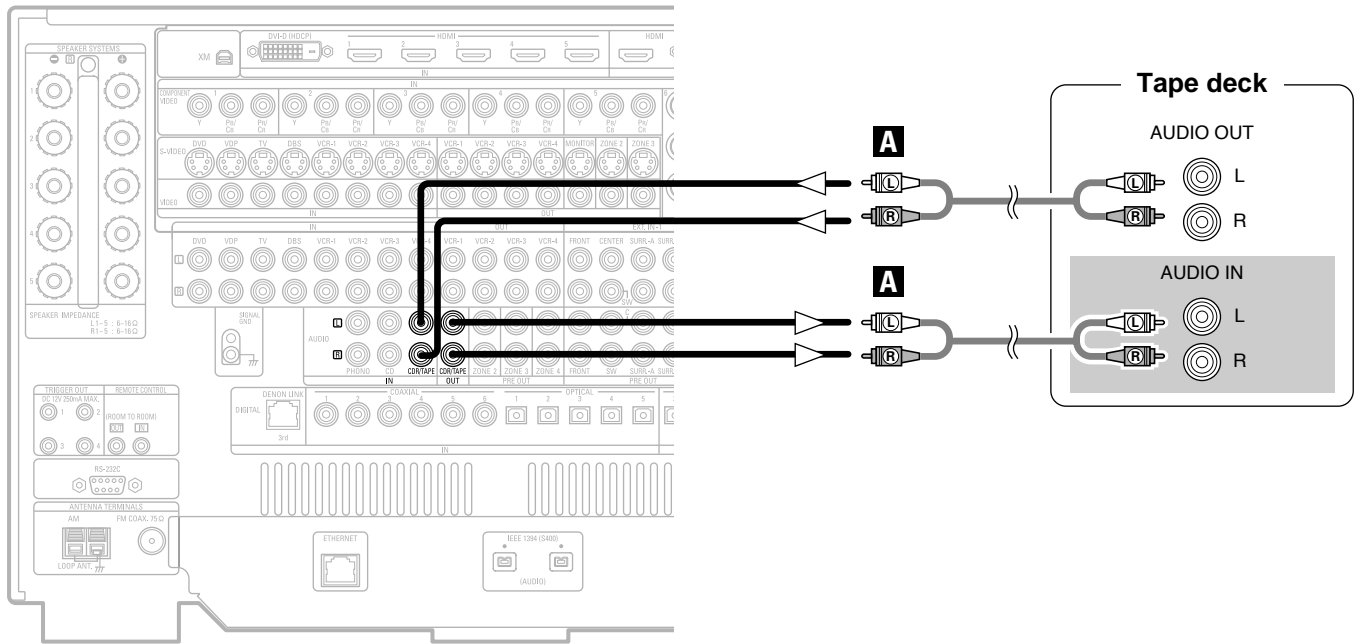

DENON LINK connection

- High quality digital sound with reduced digital signal transfer loss can be enjoyed by connecting a separately sold DENON LINK compatible DVD player.
- Digital transfer and multi-channel playback of DVD-Audio discs and other multi-channel sources is possible by connecting the AVR-5805CI to a DENON DVD player equipped with a DENON LINK connector using the connection cable included with the DVD player.
- When a DENON DVD player and the DENON LINK have been connected, be sure to make a setting to "DENON LINK" with the System Setup Digital In Assignment (🔧 page 104).

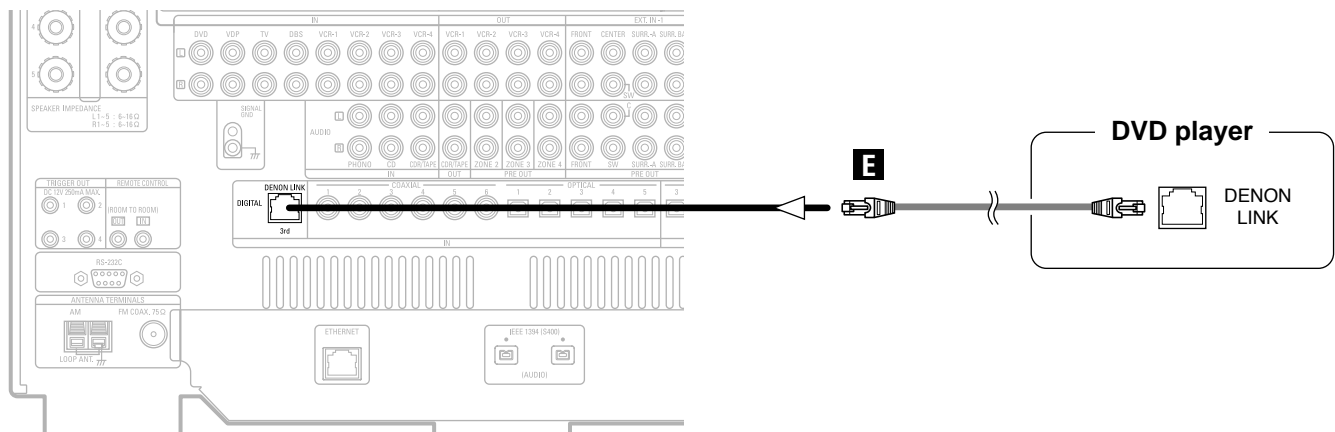

- With discs on which special copyright protection measures have been taken, however, the digital signals may not be output from the DVD player. In this case, connect the DVD player's analog multi-channel output to the AVR-5805CI's EXT. IN terminals for playback. Also refer to your DVD player's operating instructions.

Connecting Other Sources

Connecting equipment with HDMI terminals

- A simple 1-cable connection (using a commercially available cable) with a device having an HDMI (High-Definition Multimedia Interface) terminal allows digital transfer of the digital images of DVD-Video and other sources, and the multi-channel sound of DVD-Audio and DVD-Video.
- The HDMI and DVI-D monitor output terminals on the AVR-5805CI can only be used one at a time, not simultaneously.
- To provide audio output from AVR-5805CI's audio output terminal, select "AMP" at the System Setup.
- To provide audio output from the TV, select "TV" at the System Setup. For details, see "Setting the HDMI/DVI In Assignment" (🔍 page 111, 112).

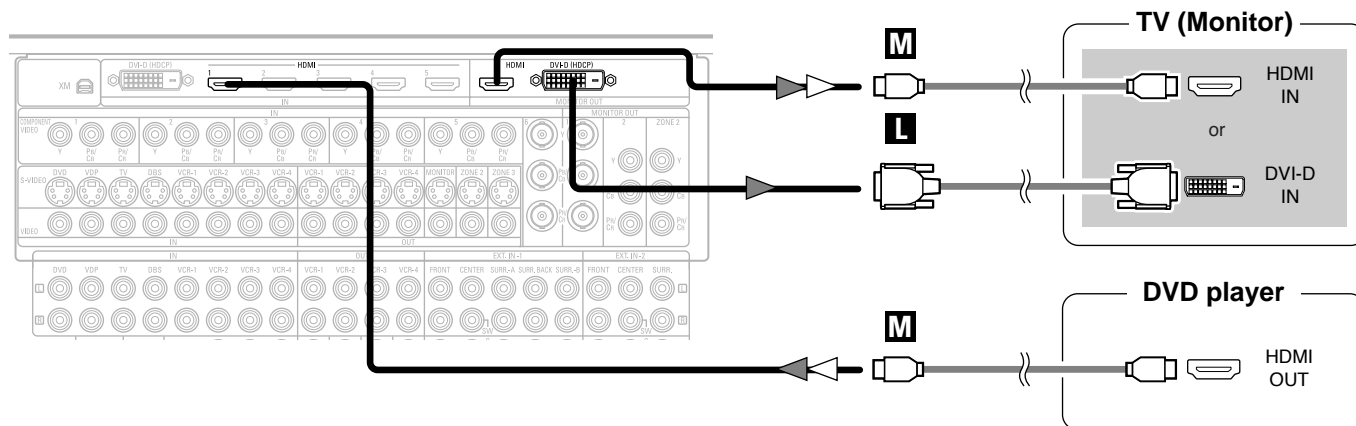

Input signals		
DVD-Video	LINEAR PCM	○
	Dolby Digital	○
	DTS	○
DVD-Audio	LINEAR PCM PACKED PCM (with CPPM / without CPPM)	○
	CD	○
Super Audio CD	Multi area	×
	Stereo area	×
	CD area	○

■ Copyright Protection System

To play back the digital video and audio of DVD-Video and DVD-Audio through an HDMI/DVI-D connection, both the connected player and monitor are required to support a copyright protection system called HDCP (High-bandwidth Digital Content Protection System). HDCP is copy protection technology that comprises data encryption and authentication of the partner equipment.

The AVR-5805CI supports HDCP. Please see the operating instruction of your video display for more information about this.

※ The AVR-5805CI is HDMI Ver. 1.1 compatible.

NOTE:

- The audio signals on the multi/stereo area of Super Audio CDs are not output. If the Super Audio CD is a hybrid CD, only the audio signals in the CD area are output.
- Use a compatible player to play DVD-Audio discs that are copyright protected by CPPM.
- Among the devices that support HDMI, some devices can control other devices via the HDMI cable; however, the AVR-5805CI cannot be controlled by another device via the HDMI cable.
- The audio signals from the HDMI terminal (including the sampling frequency and bit length) may be limited by the equipment that is connected.
- The video signals are not output properly if a device not compatible with HDCP is used.
- When "Through" is set at "Resolution" under "Setting the HDMI/Component Out Setup", use a monitor compatible with input resolutions of 480i/576i.
- The video signals input from the HDMI or DVI-D input terminals are output to the HDMI monitor with their original resolution, so the image will not be displayed if the resolutions of the input signal and the monitor being used are not matched. In this case, change the setting of the resolution on the source device (player) to one which the monitor can handle.
- The sound may be interrupted if the monitor's power is turned off when the HDMI audio signal's playback method is set to "AMP" at "Setting the HDMI/DVI In Assignment" (🔍 page 111, 112).
- Use a cable including the HDMI logo (HDMI certified product) for connection of the HDMI terminal. Normal playback may not be possible if a cable that does not include the HDMI logo (non-HDMI-certified product) is used.

Connecting equipment with DVI-D terminals

- Connection with equipment that has a DVI-D (Digital Visual Interface)-D terminal permits the transfer of digital images. Make an analog or digital audio connection also.
- The HDMI and DVI-D monitor output connectors on the AVR-5805CI can only be used one at a time, not simultaneously.

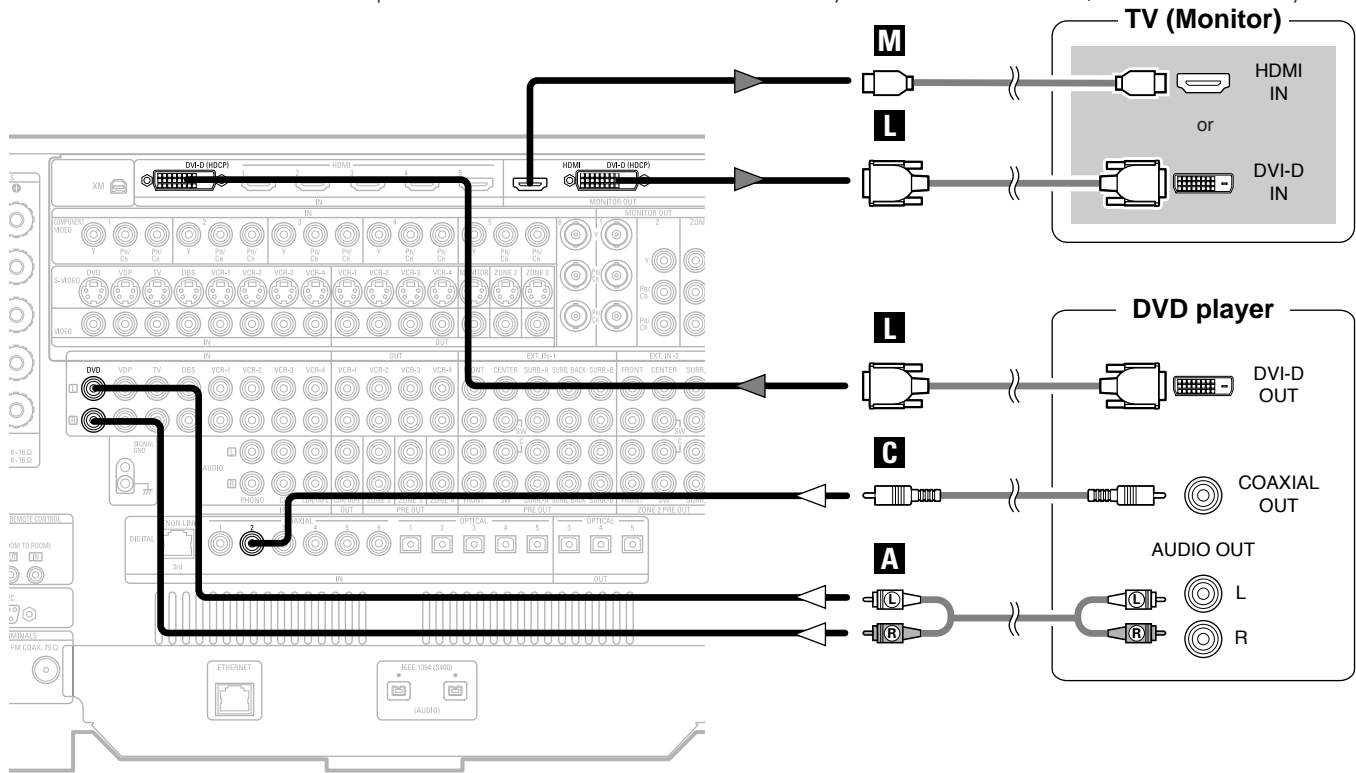

- When connecting via a DVI-D cable, no digital audio will be output from the HDMI monitor out terminal.

NOTE:

- Commercially-available DVI-D cables are available in 24-pin and 29-pin types. The AVR-5805CI supports the 24-pin DVI-D cable.
- The AVR-5805CI supports HDCP. Use an HDCP-compatible HDMI monitor.

※ Note on connecting a HDMI/DVI-D

The table below indicates the compatibility of connections between the HDMI/DVI-D output terminal of the AVR-5805CI and monitors that support HDMI/DVI-D.

	Monitor with HDMI	Monitor with DVI-D (HDCP compatible)	Monitor with DVI-D (HDCP incompatible)
HDMI output terminal	○ (Video / Audio)	○ (Only Video)	×
DVI-D output terminal	○ (Only Video)	○ (Only Video)	×



Connecting Other Sources

Connecting IEEE1394 devices

- For the digital transfer of signals from Super Audio CDs and DVD-Audio discs, connect using an IEEE1394 cable. For instructions on playing Super Audio CDs (📖 page 99).
- Assign the IEEE1394 input the input source. For details, see “Setting the IEEE1394 Assignment” (📖 page 107).

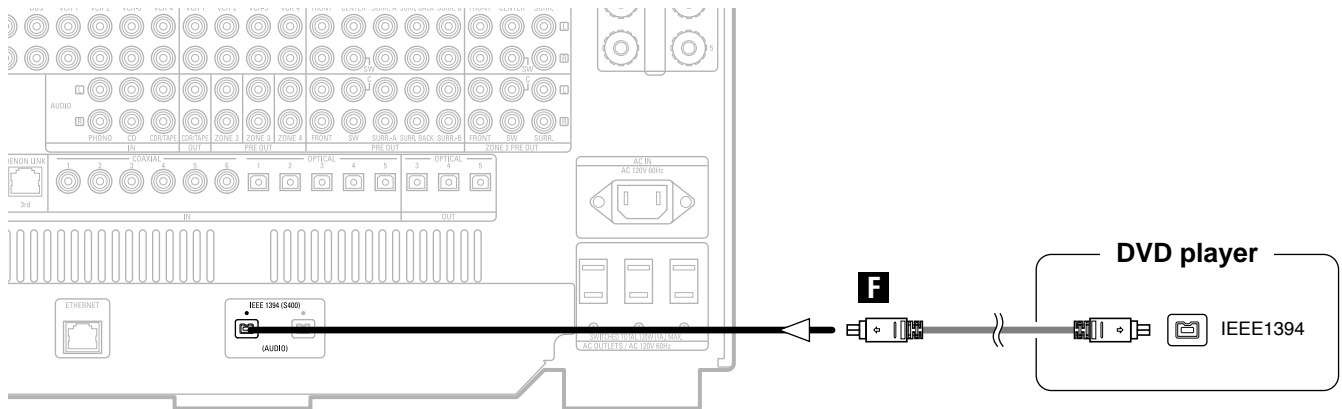

■ IEEE1394 network

- ① Up to 17 devices can be connected using daisy chain type connections.
- ② Up to 63 devices can be connected using tree type connections.
Do not loop the connections.
- ③ “LINK CHECK” is displayed when an input source to which an IEEE1394 is assigned is selected and connection to the IEEE1394 device is being checked.
- ④ If the connection is looped, “LOOP CONNECT” is displayed. Check the connections and undo the loop.

NOTE:

- Do not use an IEEE1394 cable to connect the AVR-5805CI with a computer.
- The AVR-5805CI will not operate when connected to equipment other than that conforming to “IEEE1394 AUDIO (A&M protocol)” standards or when connected to computer peripherals.
Also please note that operation is not guaranteed even when connected to IEEE1394-compatible equipment. Whether or not data and control signals can be sent and received between interconnected IEEE1394-compatible equipment depends on the functions of the different equipment. Please read the operating instructions of the equipment to be connected.
- Use an S400-compatible 4-pin IEEE1394 cable to connect.
- Video signals are not transferred with the AVR-5805CI's IEEE1394 interface, so when connecting a video device connect the video signals as well.

Connecting the antenna terminals

- An F-type FM antenna cable plug can be connected directly.

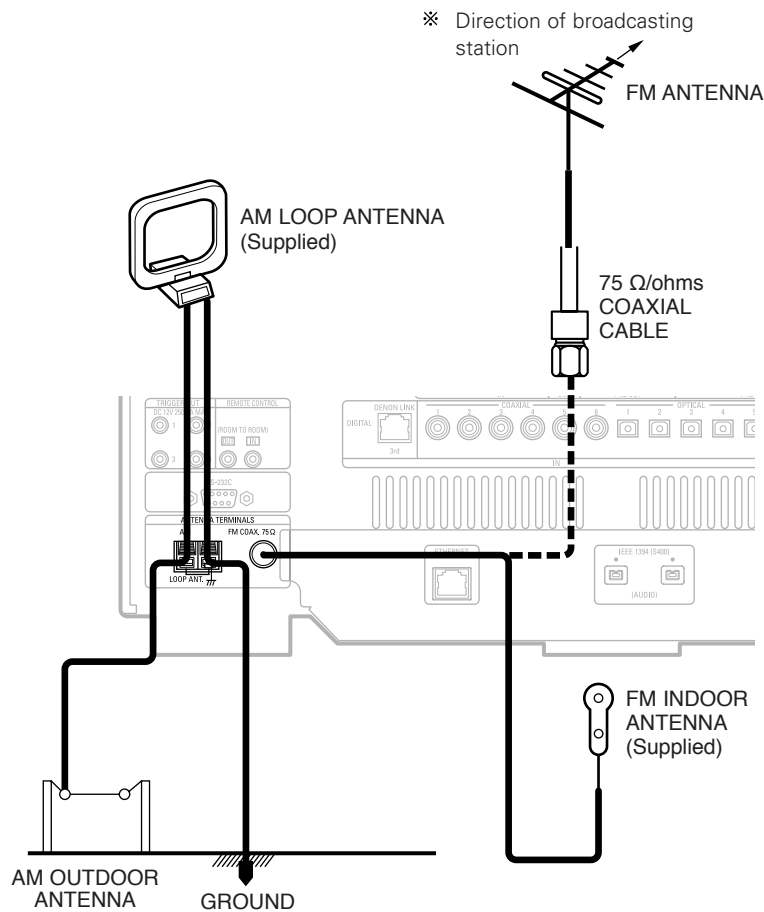

AM loop antenna assembly

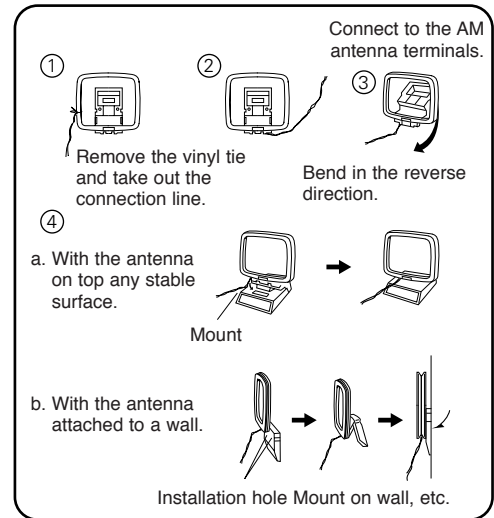

Connection of AM antennas

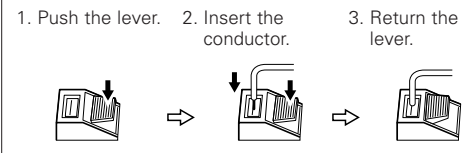

Note to CATV system installer

- This reminder is provided to call the CATV system installer's attention to Article 820-40 of the NEC which provides guidelines for proper grounding and, in particular, specifies that the cable ground shall be connected to the grounding system of the building, as close to the point of cable entry as practical.

NOTE:

- Do not connect two FM antennas simultaneously.
- Even if an external AM antenna is used, do not disconnect the AM loop antenna.
- Make sure AM loop antenna lead terminals do not touch metal parts of the panel.

Connecting Other Sources

Connecting the XM terminal

- AVR-5805CI is the XM Ready® receiver. You can receive XM® Satellite Radio by connecting to the XM Mini-Tuner and Home Dock (includes home antenna, sold separately) and subscribing to the XM service.
- Plug the XM Mini-Tuner Home Dock into XM terminal on the rear panel.
- Position the Home Dock antenna near a south-facing window to receive the best signal.

For details, see “XM Satellite Radio” (page 71).

When making connections, also refer to the operating instructions of the XM Mini-Tuner and Home Dock.

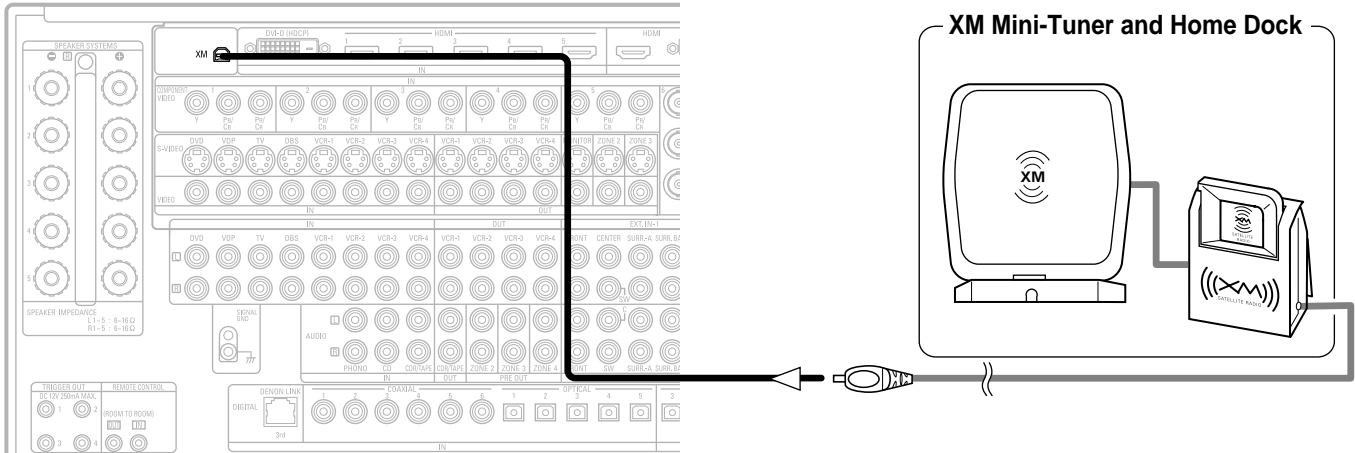

NOTE:

- Keep the power supply cord unplugged until the XM Mini-Tuner and Home Dock connection has been completed.

- The XM name and related logo are registered trademarks of XM Satellite Radio Inc. All rights reserved.
- XM Ready is a registered trademark of XM Satellite Radio Inc. All rights reserved.

Connecting the CONTROL terminal

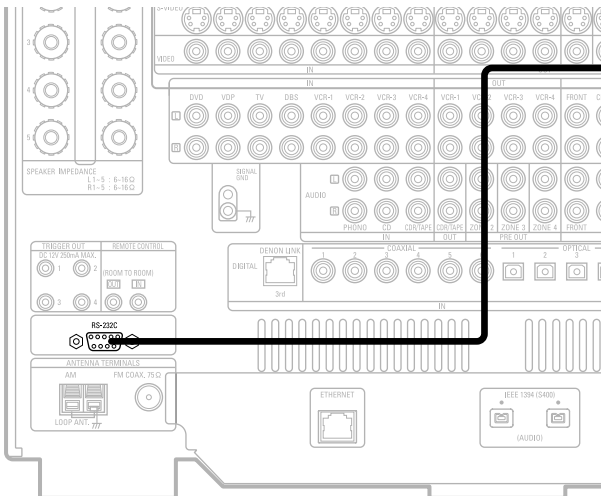

This terminal is used for an external controller.

Perform the following operation before using an external controller connected to the RS-232C terminal:

1. Press the **ON/STANDBY** button on the main unit and set the unit to the operating mode.
2. Perform the operation to turn off the power from the external control.
3. Check that the product has been set to the standby mode.

After checking the above, check the connections of the external controller. Operation is possible.

Connecting the TRIGGER OUT terminals

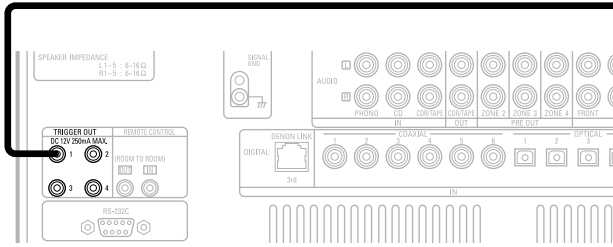

Turn the DC 12 V voltage on and off for the individual functions and surround modes. For details, see "Setting the Trigger Out" (page 135).

Connecting the MULTI ZONE terminals

※ For instructions on operations using the MULTI ZONE functions (page 87 ~ 98).

ZONE2 connections

- It is possible to connect a separate amplifier to the AVR-5805CI and simultaneously listen to a different program source than that in the MAIN ZONE in a different room (ZONE2/3/4) (page 88 ~ 92).
- The ZONE2 video out is only for the ZONE2.

※ The diagram below shows an example of connections for performing surround playback in ZONE2. For 2 channel connections in ZONE2 and for ZONE3 and ZONE4 connection examples, see pages 87 ~ 92.

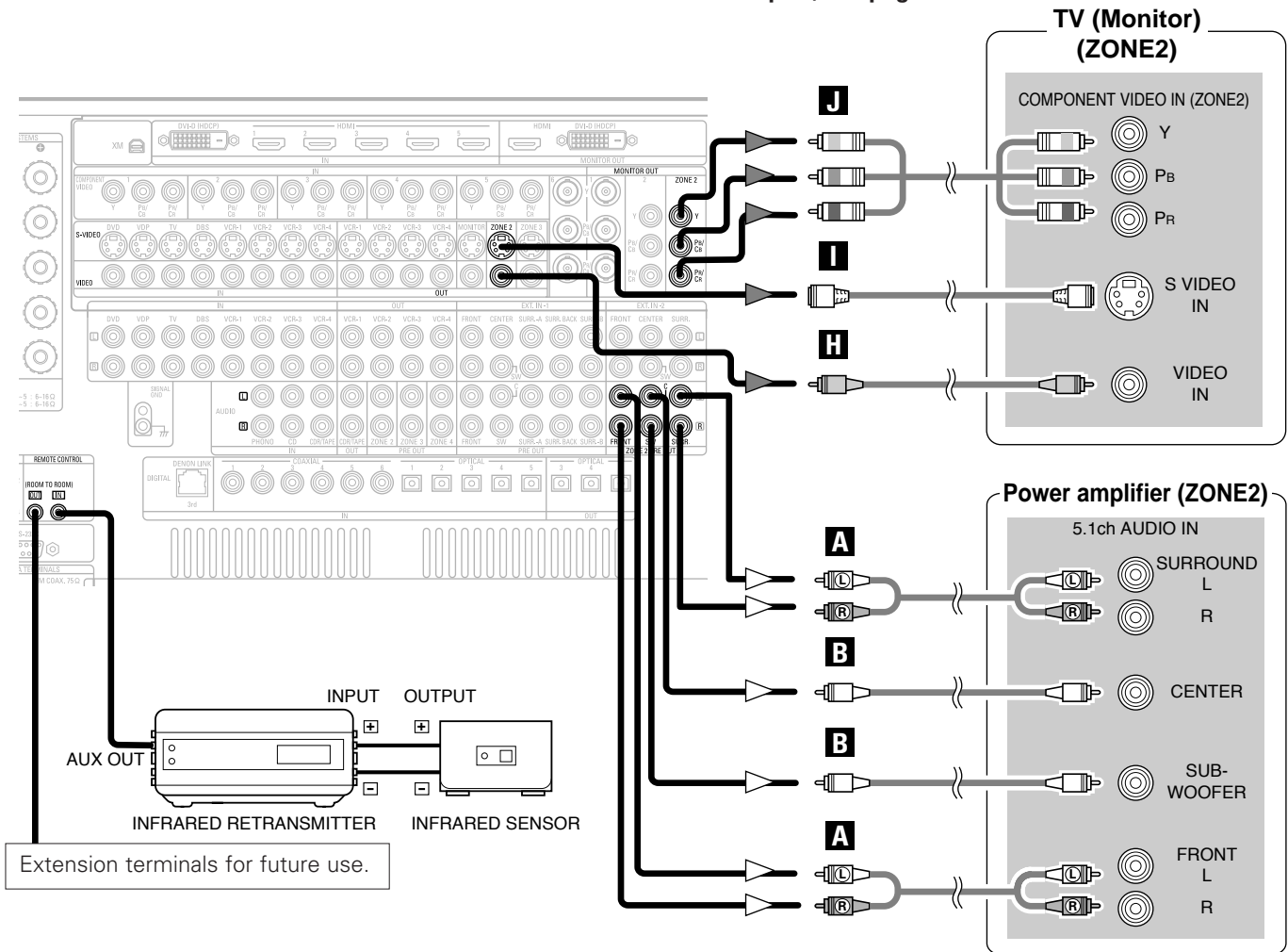

Extension terminals for future use.

NOTE:

- For the AUDIO output, use high quality pin-plug cables and wire in such a way that there is no humming or noise.
- For instructions on installation and operation of separately sold devices, refer to the devices' operating instructions.



Connecting Other Sources

Connecting the pre-out terminals

- Use these terminals if you wish to connect external power amplifier(s) to increase the power of the front, center, surround and surround back sound channels, or for connection to powered loudspeakers.
- When using only one surround back speaker, connect it to left channel.

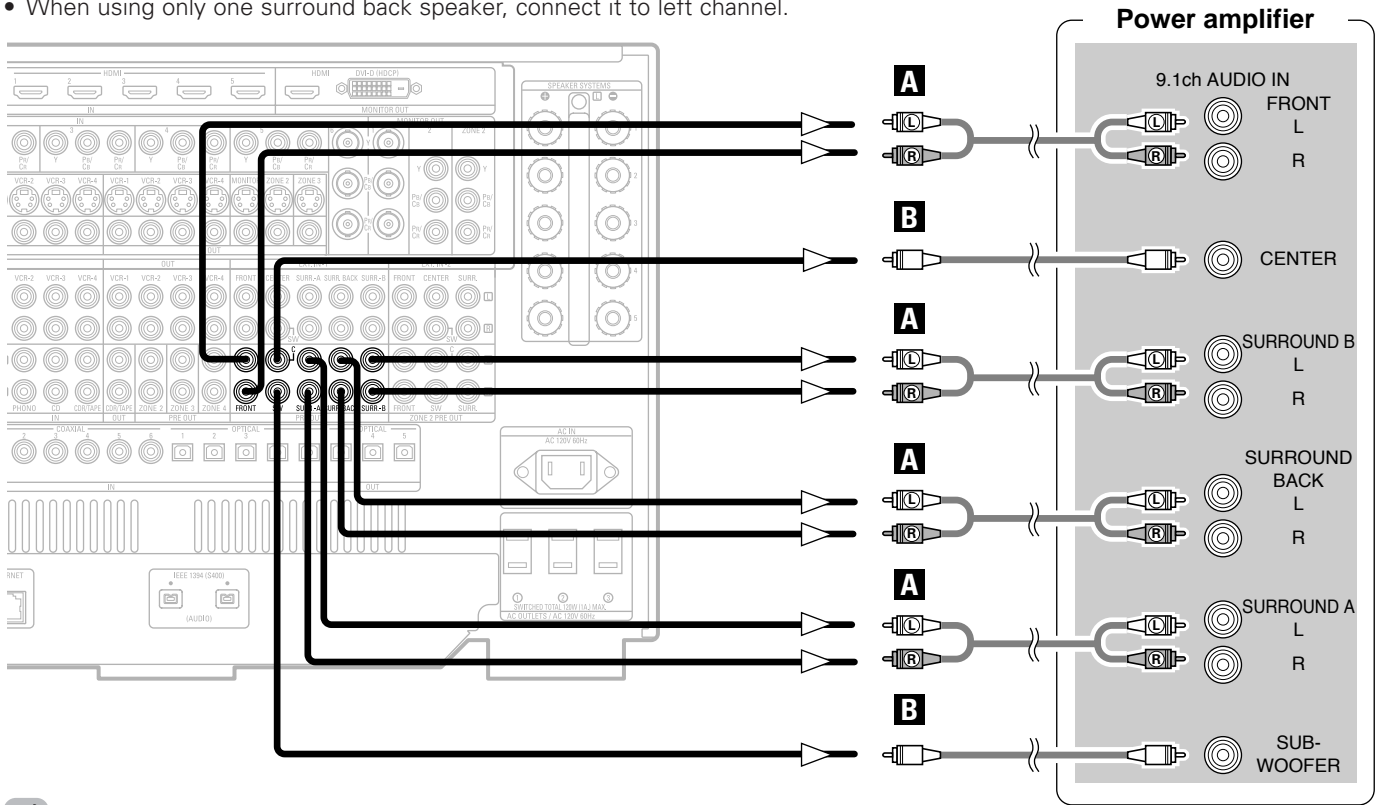

- By changing the MAIN ZONE channel settings, up to three subwoofers can be connected to the AVR-5805CI. For more information about "Setting the Channel Setup" (👉 page 126 ~ 128).

Connecting the power supply cord

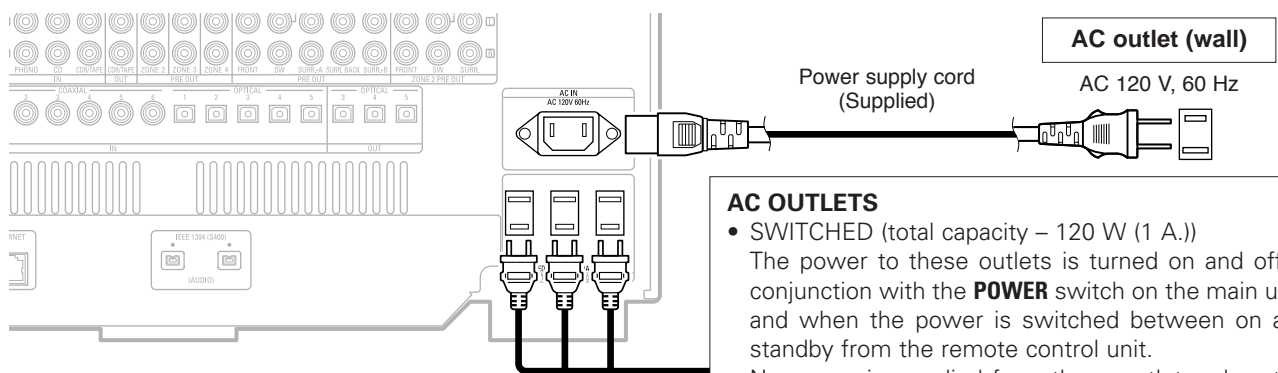

AC OUTLETS

- **SWITCHED** (total capacity – 120 W (1 A.))
The power to these outlets is turned on and off in conjunction with the **POWER** switch on the main unit, and when the power is switched between on and standby from the remote control unit. No power is supplied from these outlets when this unit's power is at standby. Never connect equipment whose total capacity is above 120 W (1 A.)



- The AC outlets can be set to turn on and off for the different functions. For details, see "Setting the AC Outlet Assignment" (👉 page 136).

NOTE:

- Only use the AC OUTLETS for audio equipment. Never use them for hair driers, TVs or other electrical appliances.
- Insert the plugs securely. Incomplete connections will result in the generation of noise.

Basic Operation

Playback

Operating the remote control unit

- The RC-1036 remote control has a backlit EL display whose contents change according to the mode or function selected, with the appropriate remote commands for that mode or function.

Operate the this unit

The **AMP** button is the main mode for controlling the AVR-5805CI in the main room (MAIN ZONE).

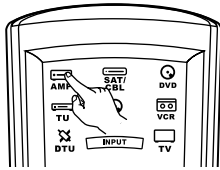

- The function switches as shown below each time one of the **AMP** button is pressed.

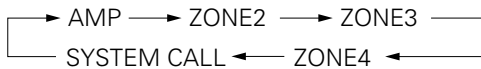

- The EL display switches as shown below with respect to the selected mode.

AMP mode

To operate the MAIN ZONE function.

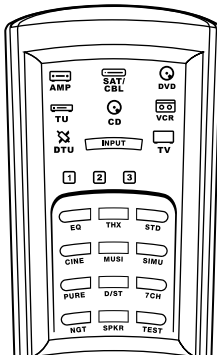

ZONE2 mode

To operate the ZONE2 function.

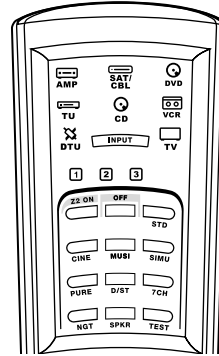

ZONE3 mode

To operate the ZONE3 function.

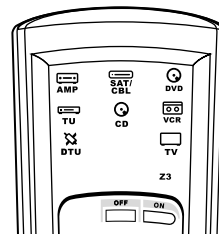

ZONE4 mode

To operate the ZONE4 function.

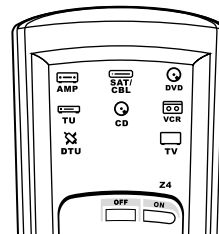

SYSTEM CALL mode

To operate the "System call" function.

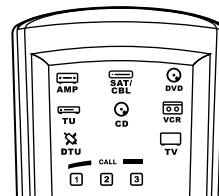

- This function provides the ability to program a series of individual remote control codes into a macro stored under one of the number pad's numeric choices (see page 84, 85).

Basic Operation

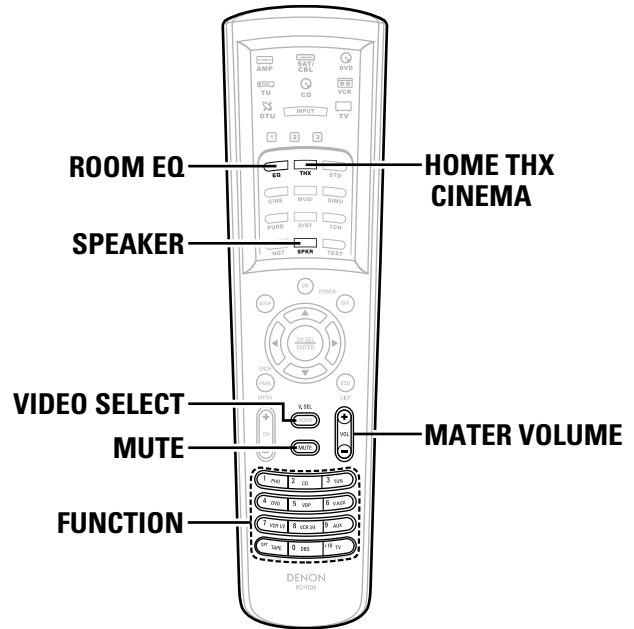
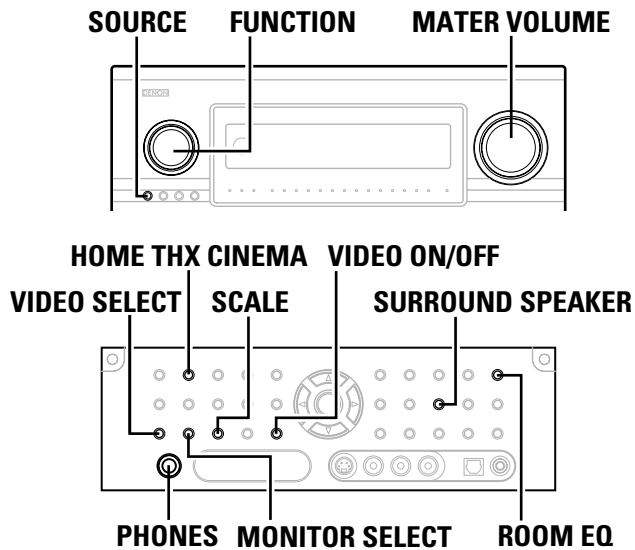

Playing the input source

1 Select the input source to be played.

- The input source indicator lights.

Example: CD

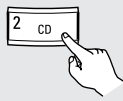
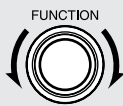

- To select the input source when ZONE2 SELECT, ZONE3/4/REC SELECT or TUNING PRESET is selected, press the **SOURCE** button on the main unit then operate the **FUNCTION** knob.

2 Start playback on the selected component.

- For operating instructions, refer to the component's manual.

3 Adjust the volume.

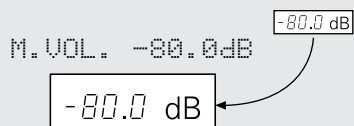

The volume level is displayed on the master volume indicator.

- The volume can be adjusted within the range of -80.0 to $+18.0$ dB, in steps of 0.5 dB. However, when the channel level is set (☞ page 64, 65 or 134), if the volume for any channel is set at $+0.5$ dB or greater, the volume cannot be adjusted up to 18.0 dB. (In this case the maximum volume adjustment range is “ 18.0 dB — (Maximum value of channel level)”.)
- Also, you may not be able to adjust the volume to the maximum of 18.0 dB when internal volume compensation control is activated due to the combination of the surround mode and parameters, downmixing from multi-channel audio signals into two channels, etc.

■ To choose the surround sound mode

Example: HOME THX CINEMA

Press the **HOME THX CINEMA** button.

- For more information about the surround modes (☞ page 51 ~ 53).

■ To select the Room EQ function

Press the **ROOM EQ** button.

- For more information about the Room EQ function (☞ page 48).

Turning the sound off temporarily (MUTING)

- Use this to mute the audio output temporarily.

Press the **MUTE** button.

- ※ You can adjust the muting level (🔊 page 134).



- Cancelling MUTING mode:
Press the **MUTE** button again, or press the **MASTER VOLUME** button on the remote panel control, or adjust the volume up or down via the front panel **MASTER VOLUME** knob.

Listening over headphones

Connect the headphone to the **PHONES** jack.

- The pre-out output (including the speaker output) is automatically turned off when headphones are connected.

NOTE:

- To prevent hearing loss, be careful not to raise the volume level excessively when using headphones.

Switching the surround speakers

Press the **SPEAKER** button.

- ※ The surround speakers switch as shown below each time the **SPEAKER** button is pressed.

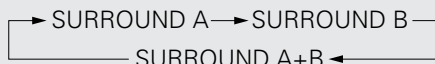

- ※ This operation is possible when the setting for using both surround speakers A and B is made at "Speaker Configuration" (🔊 page 140, 141).

Switching between HDMI and DVI-D monitor output

The monitor out terminal switch as shown below each time the **MONITOR SELECT** button is pressed.

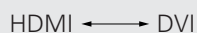

Selection of resolution setting (SCALE)

Press the **SCALE** button.

- ※ The resolution switches as follows each time the **SCALE** button is pressed.
- When "HDMI" is selected for the "Scaler" setting:
- When "Component" is selected for the "Scaler" setting:
- ※ When the **SCALE** button is pressed, the current setting is shown on the display. If the **SCALE** button is pressed while the current setting is displayed, the "Resolution" setting can be changed.
- ※ For description of the each resolution settings, see page 113 to 114.

Combining the currently playing sound with the desired image (VIDEO SELECT)

Press the **VIDEO SELECT** button until the desired image appears.

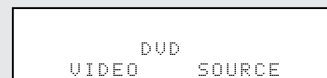

- ※ The video source selected with the video select function is stored in the memory for the different input sources.



- Cancelling simulcast playback:
Select the "SOURCE" pressing the **VIDEO SELECT** button.
- It is not possible to select HDMI and DVI input signals.
- When playing HDMI/DVI video input signals, the analog video signal of another function cannot be selected for the HDMI video output.
- If the VIDEO SELECT mode is used during playback in the XM or Network Audio, the picture switches to the picture selected from the control panel display.
Cancel the VIDEO SELECT mode if you want to display the control panel.

Video on/off

- When no video signals of a DVD, etc., are connected to the AVR-5805CI and the DVD, etc., are connected directly to a TV, etc., the unneeded video circuitry can be turned off by selecting the "VIDEO OFF" setting.

Press the **VIDEO ON/OFF** button.

Basic Operation

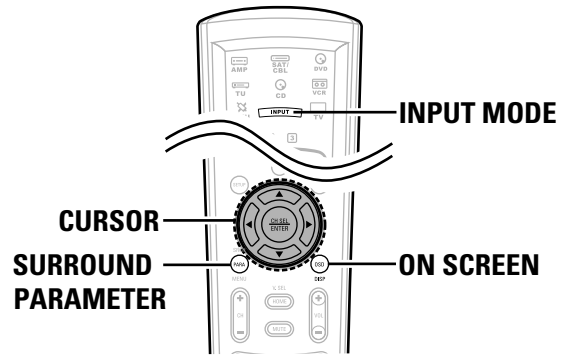
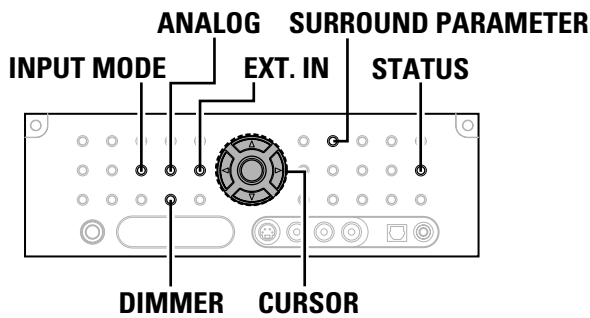

Checking the currently playing program source, etc.

■ On screen display

Press the **ON SCREEN** button.

- ※ Each time an operation is performed, a description of that operation appears on the display connected to AVR-5805CI's VIDEO MONITOR OUT terminal. Also, the unit's operating status can be checked during playback.
- ※ Such information as the position of the input selector and the surround settings is output in sequence.

■ Front panel display

Press the **STATUS** button.

- ※ Descriptions of the unit's operations are also displayed on the front panel display. In addition, the display can be switched to check the unit's operating status while playing a source.

■ Using the dimmer function

- Use this to change the brightness of the display.

Press the **DIMMER** button.

- ※ The display brightness changes in four steps (bright, medium, dim and off).

Input mode

- The AVR-5805CI has an AUTO signal detection mode that automatically identifies the type of incoming audio signals, but is also equipped with a manual mode that can be switched according to the type of input audio signals.

■ Selecting the AUTO, PCM and DTS modes

Press the **INPUT MODE** button.

- ※ The mode switches as shown below each time the **INPUT MODE** button on the main unit is pressed:



When operating the remote control unit:

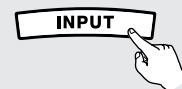

(Remote control unit)

- ※ The mode switches as shown below each time the **INPUT MODE** button on the remote control unit is pressed:

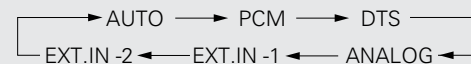

AUTO (All auto mode):

In this mode, the types of signals being input to the digital and analog input terminals for the selected input source are detected and the program in the AVR-5805CI's surround decoder is selected automatically upon playback. This mode can be selected for all input sources other than PHONO and TUNER.

The presence or absence of digital signals is detected, the signals input to the digital input terminals are identified and decoding and playback are performed automatically in DTS, Dolby Digital or PCM (2 channel stereo) format. If no digital signal is being input, the analog input terminals are selected.

Use this mode to play Dolby Digital signals.

PCM (exclusive PCM signal playback mode):

Decoding and playback are only performed when PCM signals are being input.

Note that noise may be generated when using this mode to play signals other than PCM signals.

DTS (exclusive DTS signal playback mode):

Decoding and playback are only performed when DTS signals are being input.

■ Selecting the EXT. IN mode

- 1 Press the **EXT. IN** button on the main unit or **INPUT MODE** button on the remote control unit to switch the external input.

When operating the main unit:

EXT.IN -1 ←→ EXT.IN -2

EXT. IN-1:

Once this is selected, the input signals connected to the FRONT L, FRONT R, CENTER, SURR. L A/B (surround left A/B), SURR. R A/B (surround right A/B) SBL (surround back left) and SBR (surround back right) channels of the EXT. IN terminals are output directly to the front (left and right), center, surround A/B (left and right A/B) and surround back (left and right) speaker systems as well as the pre-out terminals.

In addition, the signal input to the SW (subwoofer) terminal is output to the PRE OUT SW (subwoofer) terminal.

EXT. IN-2:

Once this is selected, the input signals connected to the FRONT L, FRONT R, CENTER, SURR. L (surround left) and SURR. R (surround right) channels of the EXT. IN terminals are output directly to the front (left and right), center and surround (left and right) speaker systems as well as the pre-out terminals.

In addition, the signal input to the SW (subwoofer) terminal is output to the PRE OUT SW (subwoofer) terminal.

- 2 Press the **SURROUND PARAMETER** button.
 - The surround parameter menu appears.

- 3 Press the **CURSOR** Δ or ∇ button to select the parameter.

2 CH:

Select when the input source being played is a 2 channel source.

MULTI CH:

Select when the input source being played is a multi-channel source.

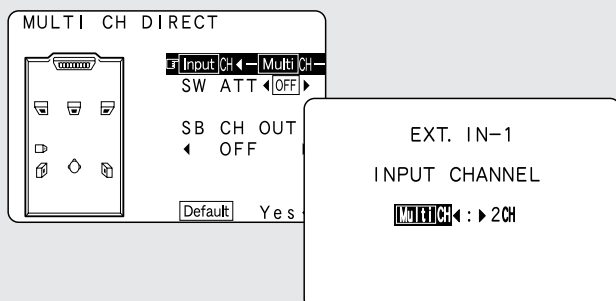

- ※ Press the **CURSOR** \triangleleft button to set the "Input channel". Press the **ENTER** button to return to the previous screen.

- 4 Press the **CURSOR** \triangleleft or \triangleright button to select the setting.

- 5 Press the **SURROUND PARAMETER** button to complete the setting.



- Cancelling the external input mode: Press the **INPUT MODE** or **ANALOG** button to switch to the desired input mode.
- The external input mode can be set for any input source. To watch video while listening to sound, select the input source to which the video signal is connected, then set this mode.
- If the subwoofer output level seems too high, set the "SW ATT" surround parameter to "ON".

Playback using the external input terminals

(EXT.IN-1 and EXT.IN-2)

- When the "ANALOG" mode is selected at "EXT.IN Setup" at the System Setup: The surround mode buttons are not operated.
- When the "DSP" mode is selected at "EXT.IN Setup" at the System Setup: The surround mode buttons are operated.

NOTE:

- When the input mode is set to EXT. IN (1 or 2), playback in the DIRECT, STEREO, STANDARD (DOLBY/DTS SURROUND), HOME THX CINEMA, 9CH STEREO and DSP SIMULATION modes are only possible when "DSP" mode is selected for the "Setting the EXT.IN Setup" (page 105).
- In play modes other than the external input mode, the signals connected to these terminals cannot be played. In addition, signals cannot be output from channels not connected to the input terminals.

■ Selecting the analog mode

Press the **ANALOG** button on the main unit or **INPUT MODE** button on the remote control unit to switch to the analog input.

ANALOG (exclusive analog audio signal playback mode):

The signals input to the analog input terminals are decoded and played.

NOTE:

- Input mode when playing DTS sources: Noise will be output if DTS-compatible CDs or LDs are played in the "ANALOG" or "PCM" mode. When playing DTS-compatible sources, be sure to connect the source component to the digital input terminals (OPTICAL/COAXIAL) and set the input mode to "DTS".

Basic Operation

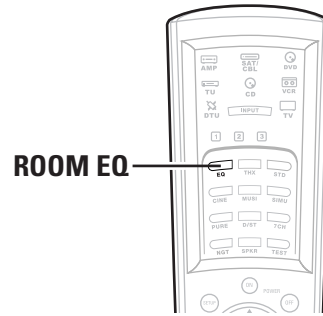
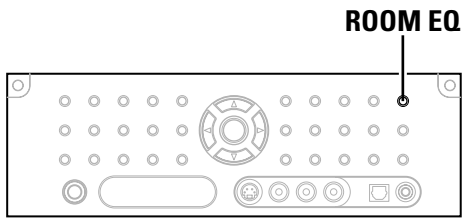

Input mode indicator

- In the AUTO mode



- In the DIGITAL PCM mode



- In the DIGITAL DTS mode



- In the ANALOG mode



- In the EXT. IN mode



Depending on the input signal.



Input signal indicator

- DOLBY DIGITAL



- DTS



- PCM

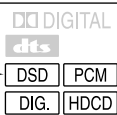

Depending on the input signal.

- The "DSD" indicator lights when the DENON LINK or IEEE1394 have been connected and the DSD signals have been input (page 35, 38).

Depending on the input signal.

- The "HDCD" indicator lights when digital signals are being input with a player that supports HDCD playback.

- ※ The "DIG." indicator lights when digital signals are being input properly. If the "DIG." indicator does not light, check whether the "Digital In Assign" (page 104) and connections are correct and whether the component's power is turned on.
- ※ AL24 processing is activated when PCM signals are played while the surround mode is set to PURE DIRECT, DIRECT, STEREO, MULTI CH PURE DIRECT, MULTI CH DIRECT or MULTI CH IN.
- ※ Advanced AL24 processing is activated when PCM (2 channel) signals are played while the surround mode is set to PURE DIRECT or DIRECT.

NOTE:

- The "DIG." indicator will light when playing CD-ROMs containing data other than audio signals, but no sound will be heard.

Room EQ function

- The AVR-5805CI's Auto Setup / Room EQ function offers three correction curves: "Audyssey", "Front", "Flat". The timbre of the speakers can also be adjusted manually using a graphic equalizer. Details of the different correction curves are described below.

Press the ROOM EQ button.

- The Room EQ switches as follows each time the **ROOM EQ** button is pressed.



- ※ The "Audyssey" is selected, the MultEQ XT indicator lights green.
- ※ The "Front" or "Flat" is selected, the MultEQ XT indicator lights red.
- ※ The MultEQ XT indicator also lights red if the "Speaker Configuration", "Delay Time", "Channel Level" or "Crossover Frequency" is set manually after conducting the Auto Setup procedure.

Audyssey:

This adjusts the frequency response of all speakers to correct the effects of room acoustics.

Front:

This adjusts the characteristics of each speaker to the characteristics of the front speakers.

Flat:

This the frequency response of all speakers flat. This is suitable for multi-channel music reproduction, from discrete music sources such as Dolby Digital 5.1, DTS, DVD-Audio and Super Audio CD.

Manual:

Selects the setting value that was set in the Manual EQ Setup. For details of the "Manual EQ Setup" (page 118, 119).



- The "Audyssey", "Front" and "Flat" Room EQ curves can be selected after performing the Auto Setup procedure.

Surround

Playing modes for different sources

- The AVR-5805CI is equipped with many surround modes. We recommend using the surround modes as described below in order to achieve the maximum effect for the specific signal source.

※  is a 6.1 channel/7.1 channel surround mode.

Sources recorded in Dolby Digital Surround EX

THX SURROUND EX (👉 page 52, 53)

- Maximum performance for playing movies on the AVR-5805CI.

DOLBY DIGITAL EX / +PLIIx*2 (👉 page 54, 55)

- This mode is optimized for playing sources recorded in Dolby Digital Surround EX.

Sources recorded in DTS-ES

DTS-ES DSCRT 6.1 / MTRX 6.1 / +PLIIx*2

(👉 page 54, 55)

- This is the optimum mode for playing sources recorded in DTS-ES.

ES DSCRT 6.1+THX / ES MTRX 6.1+THX

(👉 page 52, 53)

- When playing movies, setting this mode sometimes results in a more natural sound. Select the mode as desired.

**Dolby Digital or DTS Surround (5.1 ch sources)
2 ch sources recorded in Dolby Surround**
**THX Ultra2 CINEMA*1 / THX MUSIC MODE*1 /
THX Games Mode*1 / PLIIx C+THX**

(👉 page 52, 53)

- These modes are suited for playing 5.1 channel sources in 7.1 channels. Select the desired surround mode for the movie and music sources.

WIDE SCREEN

(👉 page 61, 62)

- Effective for 2 channel sources recorded in Dolby Surround or for 7.1 channel playback with 5.1 channel sources.

HOME THX CINEMA (THX 5.1)

(👉 page 51)

- This mode is optimized for playing 5.1 channel movies.
- For sources recorded in Dolby Surround as well, this mode provides the same power as with 5.1 channel sources.

**DOLBY DIGITAL / DOLBY DIGITAL+PLIIx*2 / DTS
SURROUND / DTS 96/24 / DTS+PLIIx*2 /
DTS+NEO:6**

(👉 page 54, 55)

- This mode is optimized for playing 5.1 channel or 7.1 channel music.
- For Dolby Surround recording sources, Dolby Pro Logic II playback is conducted.

Sources recorded in stereo

Sources recorded in monaural

PURE DIRECT

(👉 page 50)

- By suspending all circuits and processes not required, analog input music playback can be played with optimum quality.

DIRECT / STEREO

(👉 page 50)

- Effective for achieving pure playback.
- If there is no need for tone control or distribution of the low frequencies in function of the speaker configuration, select the DIRECT mode to achieve the best sound quality.

DENON Original Surround Modes

(👉 page 61, 62)

- Select these for 7.1 channel playback with sources recorded in stereo or monaural.
- The effects are different for each of the surround modes. Select the one most suited for the source being used.

DTS NEO:6

(👉 page 58)

- This is a surround mode for playing 6.1 or 7.1 channel stereo sources developed by Digital Theater Systems.
- One of two playing modes, MUSIC (for music sources) or CINEMA (for movie sources), can be selected according to your preferences.

DOLBY PRO LOGIC IIx*2

(👉 page 56, 57)

- Developed by Dolby Laboratories, this surround mode provides 7.1 channel surround sound with conventional stereo (2 channel) sources.
- Select CINEMA mode for movie surround soundtracks, MUSIC for music sources, and GAME for 2 channel game box audio sources.



- Though we recommend selecting the surround mode as described above, other surround modes can also be selected.

NOTE:

- Surround modes indicated with an asterisk (*1) require the use of two surround back speakers.
- Surround modes marked with an asterisk (*2) cannot be used when the surround back speaker is set to "NONE".
- The "+PLIIx Cinema" mode cannot be selected when only one surround back speaker is being used.

Basic Operation

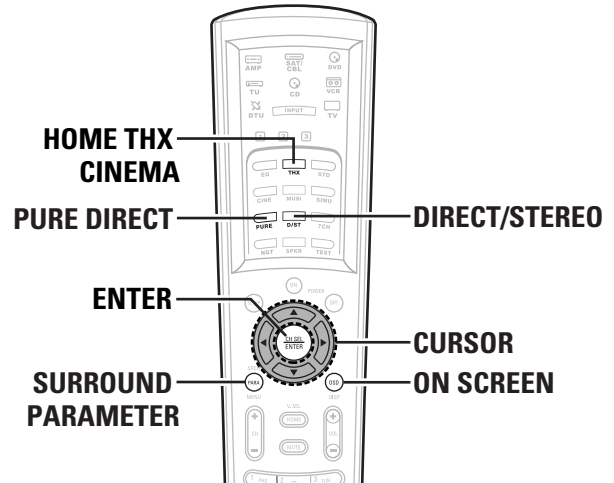
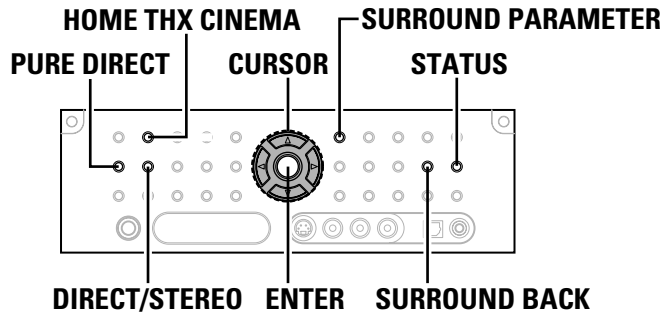

Playing audio sources (CDs and DVDs) 2 channel playback modes

- The AVR-5805CI is equipped with three 2 channel playback modes exclusively for music.
- Select the mode to suit your tastes.

■ PURE DIRECT mode

This mode reproduces the sound with extremely high quality. The audio signals do not pass through the tone circuits, etc., and the display and surrounding circuits that could affect the audio signals are turned "OFF".

Press the PURE DIRECT button to select the PURE DIRECT mode.

■ DIRECT mode

Use this mode to achieve good quality 2 channel sound. In this mode, the audio signals bypass such circuits as the tone circuit and are transmitted directly, resulting in good quality sound.

Press the DIRECT/STEREO button to select the DIRECT mode.

- ※ The mode switches as shown below each time the **DIRECT/STEREO** button on the main unit is pressed.

DIRECT ←→ STEREO

- ※ When press **SURROUND PARAMETER**:
The subwoofer output can be controlled directly.

■ STEREO mode

Use this mode to adjust the tone and achieve the desired sound.

Press the DIRECT/STEREO button to select the STEREO mode.



- The system setup function cannot be used when the PURE DIRECT mode is set. To use the system setup function, cancel the PURE DIRECT mode.
- If the HDMI input terminal is selected, video outputs are output in the PURE DIRECT mode.
- The channel level and surround parameters in the PURE DIRECT mode are the same as in the DIRECT mode.

THX Surround EX / Home THX Cinema mode

- When the **HOME THX CINEMA** button is pressed, the surround mode is set as follows according to the signal that is played:
 - THX Surround EX (THX Ultra2 Cinema)
 - Home THX CINEMA (PLIIx C + THX)
 - THX 5.1
 - ES DSCRT 6.1 +THX, ES MTRX 6.1 + THX
- When the HOME THX CINEMA mode is set when a DVD is played, check the DVD player's digital output setting and change the setting to one for which Dolby Digital and DTS bit stream signals can be output ("bit stream", for example).

Playing sources recorded in Dolby Surround in the Home THX Cinema Surround mode

1 Press the **HOME THX CINEMA** button to select "Home THX Cinema" mode.

2 Play a program source with the  mark.

- For operating instructions, refer to the manuals of the respective components.

3 Press the **SURROUND PARAMETER** button.

- The surround parameter menu appears.

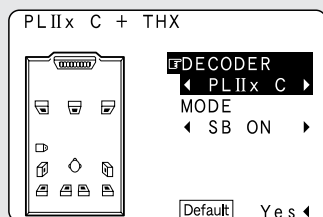

4 Press the **CURSOR** Δ or ∇ button to select the parameter.

5 Press the **CURSOR** \triangleleft or \triangleright button to select the setting.

6 Press the **ENTER** or **SURROUND PARAMETER** button to complete the setting.

To play in the THX Surround EX / Home THX Cinema Surround mode for sources recorded in Dolby Digital or DTS

1 Press the **HOME THX CINEMA** button to select "Home THX Cinema" mode.

2 Play a program source with the ,  mark.

- The Dolby Digital indicator lights when playing Dolby Digital sources.
- The DTS indicator lights when playing DTS sources.



lights



lights

- For operating instructions, refer to the manuals of the respective components.
- The channel status information during playback of Dolby Digital and DTS sources can be checked pressing the **STATUS** button on the main unit.
- Press the **SURROUND BACK** button. Lights when the Surround Back channel is on.

Set to "1spkr"



lights

Set to "2spkr"

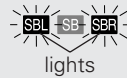

lights

Basic Operation

■ Surround parameters ①

DECODER:

Select the decoder to be used when playing 2 channel sources in the Home THX Cinema mode.

- **PLIIx C:**
The signals are decoded in the Dolby Pro Logic IIx Cinema mode before undergoing THX processing.
- **PLII C:**
The signals are decoded in the Dolby Pro Logic II Cinema mode before undergoing THX processing.
- **PL:**
The signals are decoded in the Dolby Pro Logic mode before undergoing THX processing.
- **NEO:6 C:**
The signals are decoded in the NEO:6 Cinema mode before undergoing THX processing.

MODE/SB CH OUT:

Select the surround back channel playback method or mode.

- **ON:**
This is the recommended play mode for using the surround back channel when DTS NEO:6 is selected.
- **OFF:**
This is the recommended play mode when Dolby Pro Logic II is selected. The surround back channel is not played.

■ Checking the input signal

- The input signal can be checked by pressing the remote control unit's **ON SCREEN** button.

SIGNAL:

Displays the type of signal (DTS, DOLBY DIGITAL, PCM, etc.).

fs:

Displays the input signal's sampling frequency.

FORMAT:

Displays the input signal's number of channels.
"Number of front channels/Number of surround channels/LFE on/off"
"SURROUND" is displayed for 2 channel signal sources recorded in Dolby Surround.

OFFSET:

Displays the dialog normalization offset value (🔊 page 55).

FLAG:

Displays the special identification signal recorded in the input signal.
"MATRIX" is displayed if the input signal has undergone matrix processing, "DISCRETE" is displayed if the input signal has undergone discrete processing.
Not displayed when no identification signal is recorded.

- In addition, screen information is displayed in the following order when the **ON SCREEN** button is pressed repeatedly:

OSD-1	Audio input signal
OSD-2	Monitor information
OSD-3	Input/output
OSD-4	Auto surround mode
OSD-5	USER MODE 1
OSD-6	USER MODE 2
OSD-7	USER MODE 3
OSD-8~14	Tuner preset stations

```
[Mode]:Dolby Digital EX
RoomEQ:OFF
SIGNAL:DOLBY DIGITAL
fs      :48kHz
FORMAT:3/2/.1
OFFSET:-4dB
OSD-1
```

```
[Mode]:DTS ES DSCRT6.1
RoomEQ:OFF
SIGNAL:DTS
fs      :48kHz
FORMAT:3/3/.1
FLAG   :DISCRETE
OSD-1
```

NOTE:

- OSD-2:
The monitor's resolution is displayed when an HDMI monitor is connected to the AVR-5805CI.
- OSD-4:
This is displayed when the auto surround mode is set to "ON" (🔊 page 117) and the input mode is set to "AUTO".
It is not displayed when the input mode is set to "ANALOG" or "EXT. IN".

■ Surround parameters ②

MODE/SB CH OUT:

Select the surround back channel playback method or mode.

(1) (Multi channel source)

THX Surround EX:

Dolby Digital signals are played in the "THX Surround EX" mode.

Ultra2 Cinema:

The signals are played in the THX Ultra2 Cinema mode.

Music Mode:

The signals are played in the THX Music mode.

Games Mode:

The signals are played in the THX Games mode.

NON MTRX:

The same signals as those of the surround channels are output from the surround back channels.

MTRX ON:

The surround channel signals undergo digital matrix processing and are output from the surround back channels.

SB OFF (OFF):

No signal is played from the surround back channels.

ES MTRX:

When playing DTS signals, the surround back signals undergo digital matrix processing for playback.

ES DSCRT:

When a signal identifying the source as a discrete 6.1 channel source is included in the DTS signals, the surround back signals included in the source are played.

PLIIx Cinema:

Processing is performed with the Cinema mode of the PLIIx decoder and the surround back channel is reproduced.

PLIIx Music:

Processing is performed with the Music mode of the PLIIx decoder and the surround back channel is reproduced.

(2) (2ch source)

OFF:

Playback is conducted without using the surround back speaker.

ON:

Playback is conducted using the surround back speaker.

※ This operation can be performed directly pressing the **SURROUND BACK** button.

AFDM (Auto Flag Detect Mode):

• ON:

This function only works with software on which a special identification signal is recorded. This software is scheduled to go on sale in the future.

This is a function for automatically playing in the 6.1 channel mode using the surround back speaker(s) if the software is recorded in Dolby Digital EX or DTS-ES or in the normal 5.1 channel mode without using the surround back speaker(s) when the software is not recorded in Dolby Digital EX or DTS-ES.

When AFDM is set to "ON" and the EX/ES flag is detected automatically, the surround mode is fixed according to the playing program source.

In this case, the "MODE/SB CH OUT" parameter can not be selected on the surround parameter screen.

• OFF:

When the identification signal is detected automatically and you would like to select the surround mode freely, set AFDM to "OFF".

In this case, the "MODE/SB CH OUT" parameter can be selected on the surround parameter screen regardless of the playing program source.

Example: When playing software that has a Dolby Digital EX flag

- When AFDM is set to "ON", the surround mode is automatically set to the "DOLBY DIGITAL + PLIIx CINEMA" mode. The surround parameter screen shown at the below is displayed.

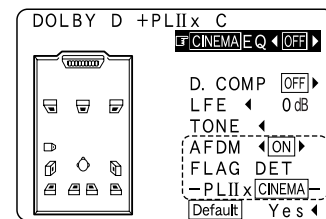

- When you would like to play back with the "Dolby Digital EX" mode, set AFDM to "OFF" and select "MTRX ON" with "SB CH OUT".

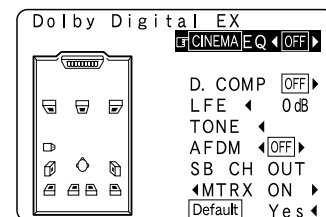

※ Some discs recorded in Dolby Digital EX do not include EX flag. If the playing mode does not switch automatically when the AFDM turns "ON" during playback, manually set "SB CH OUT" to "PLIIx Cinema" or "MTRX ON".

Basic Operation

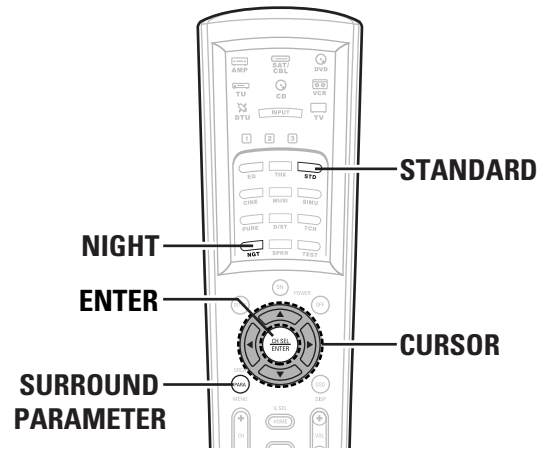
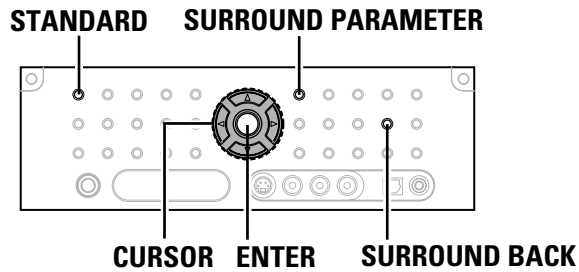

Dolby Digital mode and DTS Surround (only with digital input)



1 Press the **STANDARD** button to select “STANDARD (Dolby/DTS Surround)” mode.

2 Play a program source with the   mark.

- The Dolby Digital indicator lights when playing Dolby Digital sources.
- The DTS indicator lights when playing DTS sources.



※ Press the **SURROUND BACK** button. Lights when the Surround Back channel is on.

Set to “1spkr”  Set to “2spkr” 
lights lights

3 Press the **SURROUND PARAMETER** button.
• The surround parameter menu appears.

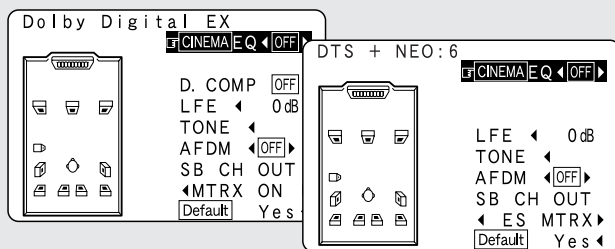

4 Press the **CURSOR**  or  button to select the parameter.

5 Press the **CURSOR**  or  button to select the setting.

6 Press the **ENTER** or **SURROUND PARAMETER** button to complete the setting.



- Select “Default Yes” and press the **CURSOR**  button to reset all the settings.

■ Surround parameters ③

CINEMA EQ. (Cinema Equalizer):

The Cinema EQ function gently decreases the level of the extreme high frequencies, compensating for overly-bright sounding motion picture soundtracks. Select this function if the sound from the front speakers is too bright.

This function only works in the Dolby Pro Logic IIx, Dolby Pro Logic, Dolby Digital, DTS Surround, DTS NEO:6 and WIDE SCREEN modes.

D.COMP. (Dynamic Range Compression):

Motion picture soundtracks have tremendous dynamic range (the contrast between very soft and very loud sounds). For listening late at night, or whenever the maximum sound level is lower than usual, the Dynamic Range Compression allows you to hear all of the sounds in the soundtrack (but with reduced dynamic range). (This only works when playing program sources recorded in Dolby Digital or DTS.) Select one of the four parameters (“OFF”, “LOW”, “MID” (middle) or “HI” (high)). Set to OFF for normal listening.

This parameter is displayed only when playing compatible sources in DTS mode.

LFE (Low Frequency Effect):

This sets the level of the LFE (Low Frequency Effect) sounds included in the source when playing program sources recorded in Dolby Digital, DTS, DVD-Audio or Super Audio CD.

Program source and adjustment range:

1. Dolby Digital: -10 dB to 0 dB
2. DTS Surround: -10 dB to 0 dB

※ **When DTS encoded movie software is played, it is recommended that the LFE LEVEL be set to 0 dB for correct DTS playback.**

※ **When DTS encoded music software is played, it is recommended that the LFE LEVEL be set to -10 dB for correct DTS playback.**

TONE:

This adjusts the tone control ( page 63, 64).

This can be set individually for the separate surround mode other than PURE DIRECT, DIRECT and Home THX Cinema mode.

■ Dialogue Normalization

Dialogue Normalization (Dial Norm) is a feature of Dolby Digital, which is used to keep the programs at the same average listening level so the user does not have to change the volume control between Dolby Digital programs. When playing back software which has been encoded in Dolby Digital, sometimes you may see a brief message in the front panel display which will read "Dial Norm X dB" (X being a numeric value). The display is showing how the program level relates with THX calibration level. If you want to play the program at calibrated theatrical levels, you may wish to adjust the volume. For example, if you see the following message: "Dial Norm + 4 dB" in the front panel display, to keep the overall output level at THX calibrated loudness, just turn down the volume control by 4 dB. However, unlike a movie theater where the playback loudness is preset, you can choose your preferred volume setting for best enjoyment.

Display

```
Dial.Norm
Offset -4dB
```

Night mode

When listening at night or at lower volumes, the night mode improves listenability.

Press the NIGHT button on the remote control unit to enter the night mode.



- Canceling night mode:
Press the **NIGHT** button again.
- The night mode only works when playing program sources recorded in Dolby Digital.
- When the night mode is set to "ON", the "D.COMP" surround parameter can not be selected.

Basic Operation

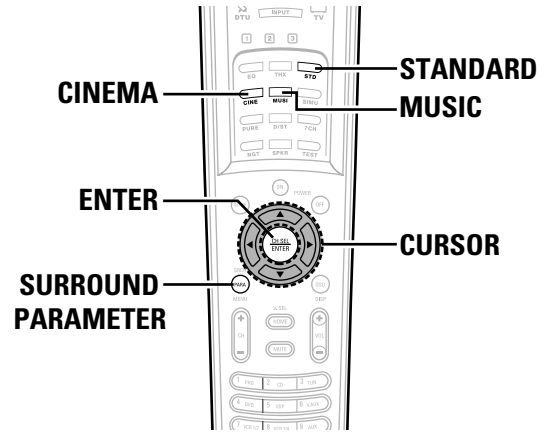
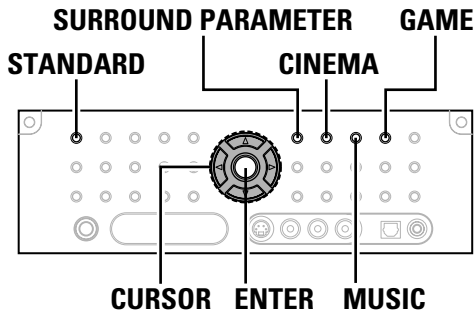

Dolby Pro Logic IIx (Pro Logic II) mode

- To play in the PLIIx mode, set “Sp.Back” at the Speaker Configuration setting to “1spkr” or “2spkr”.
- To play in the PLIIx mode, set “Surround Back” at the Power Amp Assign setting.
- This mode is optimal for playing program sources recorded in Dolby Surround.

1 Press the **STANDARD** button to select “Dolby Pro Logic IIx” mode.

- The Dolby Pro Logic indicator lights.



- ※ The mode switches as shown below each time the **STANDARD** button is pressed.

DOLBY PLIIx ←→ DTS NEO:6

2 Play a program source.

- ※ For operating instructions, refer to the manuals of the respective components.

3 Press the **SURROUND PARAMETER** button.

- The surround parameter menu appears.

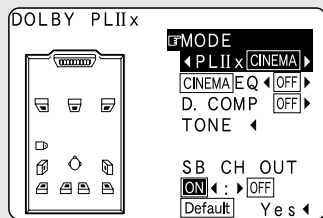

4 Press the **CURSOR** < or > button to select the play mode.

- ※ When the “SB CH OUT” parameter is set to “ON”. (Set “SP.Back” at the System Setup to “1spkr” or “2spkr”).

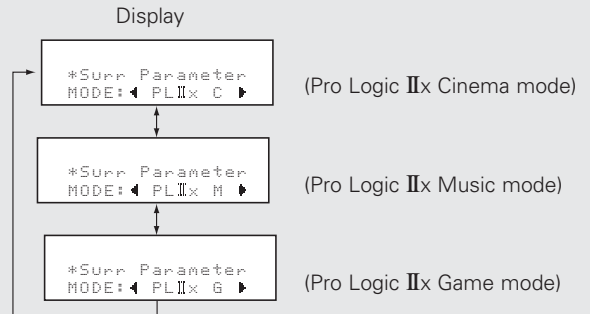

- ※ When the “SB CH OUT” parameter is set to “OFF”. (Set “SP.Back” at the System Setup to “None”).

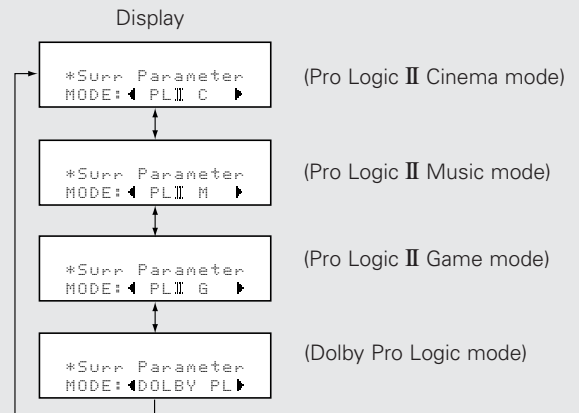

5 Press the **CURSOR** Δ or ∇ button to select the various surround parameters.

Example: DOLBY PLIIx Music mode screen

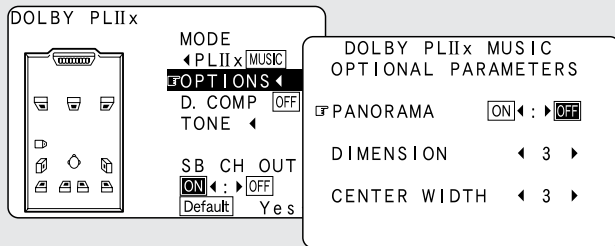

- ※ When set with the on screen display while in the MUSIC mode, set the "☐" mark to "OPTIONALS ◀" pressing the **CURSOR** Δ or ∇ button, then press the **CURSOR** ◀ button.
Press the **ENTER** button to return to the previous screen.

6 Press the **CURSOR** ◀ or ▶ button to adjust the parameters setting.

- ※ **Default setting:**
Press the **CURSOR** ◀ button to select "Default Yes ◀", then parameters set to default setting.

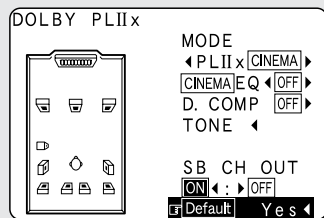

7 Press the **ENTER** or **SURROUND PARAMETER** button to complete the setting.



- The Dolby Pro Logic IIx (Pro Logic II) Cinema, Music or Game mode can be chosen directly by pressing the **CINEMA**, **MUSIC** or **GAME** button during playback in the Dolby Pro Logic IIx (Pro Logic II) mode.

■ Surround parameters ④

Pro Logic IIx and Pro Logic II Mode:

Select one of the modes ("Cinema", "Music", "Pro Logic" or "Game").

The Cinema mode is for use with stereo television shows and all programs encoded in Dolby Surround.

The Music mode is recommended for stereo music and surround-encoded stereo music sources.

The Pro Logic mode emulates Dolby Laboratories' original Dolby Pro Logic surround decoding, and may provide better results with older, legacy surround-encoded program material.

The Game mode is optimized for computer and/or dedicated game box consoles, that feature stereo analog or digital outputs. It can only be used with 2 channel stereo sources.

PANORAMA:

This mode extends the front stereo image to include the surround speakers for an exciting "wraparound" effect with side wall imaging.

Select "OFF" or "ON".

DIMENSION:

This control gradually adjust the soundfield either towards the front or towards the rear.

The control can be set in 7 steps from 0 to 6.

CENTER WIDTH:

This control adjust the center image so it may be heard only from the center speaker; only from the left/right speakers as a phantom image; or from all three front speakers to varying degrees.

The control can be set in 8 steps from 0 to 7.

Basic Operation

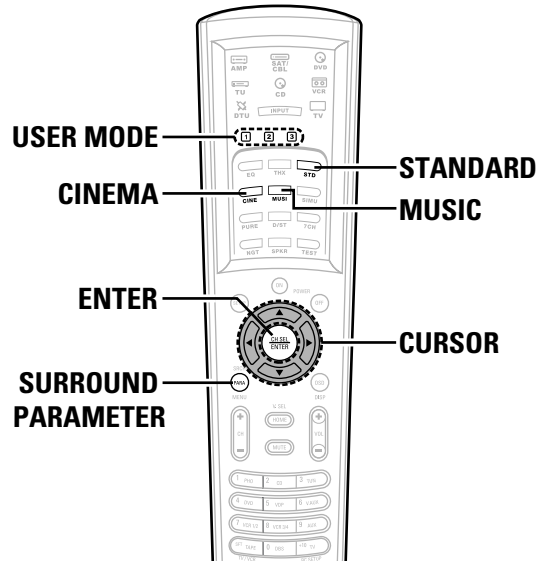
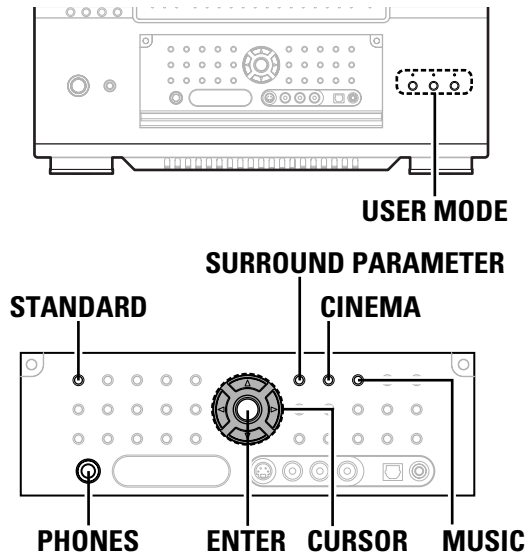

DTS NEO:6 mode

- Surround playback can be performed for the analog input and digital input 2 channel signals.

1 Press the **STANDARD** button to select “DTS NEO:6” mode.

- The DTS NEO:6 indicator lights.

- ※ The mode switches as shown below each time the **STANDARD** button is pressed.

DOLBY PLIIx ← → DTS NEO:6



2 Play a program source.

3 Press the **SURROUND PARAMETER** button.

- The surround parameter menu appears.

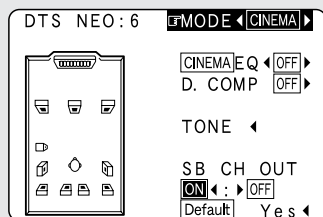

4 Press the **CURSOR** ◀ or ▶ button to select the play mode.

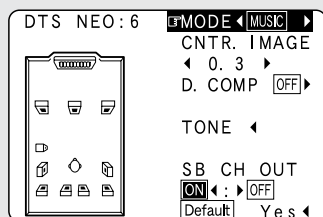

5 Press the **CURSOR** ▲ or ▼ button to select the various surround parameters.

6 Press the **CURSOR** ◀ or ▶ button to adjust the parameters setting.

7 Press the **ENTER** or **SURROUND PARAMETER** button to complete the setting.



- Select “Default Yes” and press **CURSOR** ◀ button to reset all the settings.
- When playing PCM digital signals or analog signals in the DOLBY PRO LOGIC II, DOLBY PRO LOGIC IIx, DTS NEO:6 modes and the input signal switches to a digital signal encoded in Dolby Digital, the Dolby Surround mode switches automatically. When the input signal switches to a DTS signal, the mode automatically switches to DTS Surround.
- The DTS NEO:6 Cinema or Music mode can be chosen directly by pressing the CINEMA or MUSIC button on the Remote control unit during playback in the DTS NEO:6 mode.

■ Surround parameters ⑤

DTS NEO:6 Mode:

• Cinema:

This mode is optimum for playing movies. Decoding is performed with emphasis on separation performance to achieve the same atmosphere with 2 channel sources as with 6.1 channel sources.

This mode is effective for playing sources recorded in conventional surround formats as well, because the in-phase component is assigned mainly to the center channel (C) and the reversed phase component to the surround (SL, SR and SB channels).

• Music:

This mode is suited mainly for playing music. The front channel (FL and FR) signals bypass the decoder and are played directly so there is no loss of sound quality, and the effect of the surround signals output from the center (C) and surround (SL, SR and SB) channels add a natural sense of expansion to the sound field.

CENTER IMAGE (0.0 to 1.0: default 0.3):

The center image parameter for adjusting the expansion of the center channel in the DTS NEO:6 MUSIC mode has been added.

The Dolby Headphone

- The Dolby Headphone mode is set when headphones are connected to the **PHONES** jack while in the STANDARD (DOLBY/DTS SURROUND) mode.

1 Press the **SURROUND PARAMETER** button.

- The surround parameter menu appears.

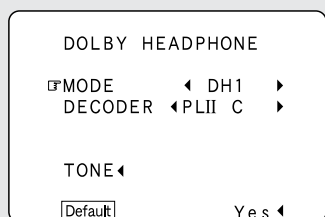

2 Press the **CURSOR** Δ or ∇ button to select the parameter.

3 Press the **CURSOR** \triangleleft or \triangleright button to select the setting.

4 Press the **ENTER** or **SURROUND PARAMETER** button to complete the setting.



- When RECOUT mode is set to "SOURCE", with this amplifier signals encoded in the Dolby Headphone mode can be output from the recording output terminals and recorded on another recorder (📖 page 101).

Parameters

MODE:

- DH1:**
Reference room (small room with weak reverberations).
- DH2:**
Live room (room with a bit stronger reverberations than DH1).
- DH3:**
Large room (larger room than DH1, offers a sense of distance and sound diffusion effects).
- BYPASS:**
Stereo sound.

DECODER:

- Select this when playing analog, PCM or other 2 channel sources.
The signals are converted into multichannel signals using the decoders shown below and played in the Dolby Headphone mode.
- PLII C:**
Dolby Pro Logic II Cinema mode.
- PLII M:**
Dolby Pro Logic II Music mode.
- NEO:6 C:**
DTS NEO:6 Cinema mode.
- NEO:6 M:**
DTS NEO:6 Music mode.
- OFF:**
The signals are played in the Dolby Headphone mode as such (2 channels).

USER MODE function

- The AVR-5805CI is equipped with a function for storing the selected input source, the auto surround mode and input mode in the memory and selecting these settings when you want to use them.
- Three patterns of settings can be stored in the memory pressing the **USER MODE** buttons.

Storing the settings in the memory

1 The following are stored in the memory:

- Currently set input source
- Currently set auto surround mode
- Currently set input mode

2 Press and hold the **USER MODE** button until the "USER MODE" indicator lights.

Calling the settings out

Press the **USER MODE** button at which the settings you want to call out are stored.

- The user mode indicator lights.
- ※ The indicator turns off if you perform any operations that change the settings stored at the **USER MODE** buttons.

Basic Operation

DENON original surround modes

- The AVR-5805CI is equipped with a high performance DSP (Digital Signal Processor) which uses digital signal processing to synthetically recreate the sound field. One of ten preset surround modes can be selected according to the program source and the parameters can be adjusted according to the conditions in the listening room to achieve a more realistic, powerful sound.

Surround modes and their features

1	WIDE SCREEN	Select this to achieve an atmosphere like that of a movie theater with a large screen. In this mode, all signal sources are played in the 7.1 channel mode, including Dolby Surround and Dolby Digital 5.1 channel sources. Effects simulating the multi surround speakers of movie theaters are added to the surround channels.
2	SUPER STADIUM	Select this when watching baseball or soccer programs to achieve a sound as if you were actually at the stadium. This mode provides the longest reverberation signals.
3	ROCK ARENA	Use this mode to achieve the feeling of a live concert in an arena with reflected sounds coming from all directions.
4	JAZZ CLUB	This mode creates the sound field of a live house with a low ceiling and hard walls. This mode gives jazz a very vivid realism.
5	CLASSIC CONCERT	Select this for the sound of a concert hall rich in reverberations.
6	MONO MOVIE (NOTE)	Select this when watching monaural movies for a greater sense of expansion.
7	VIDEO GAME	Use this to enjoy video game sources.
8	MATRIX	Select this to emphasize the sense of expansion for music sources recorded in stereo. Signals consisting of the difference component of the input signals (the component that provides the sense of expansion) processed for delay are output from the surround channel.
9	VIRTUAL	Select this mode to enjoy a virtual sound field, produced from the front 2 channel speakers. ※ This mode can be selected when surround playback is being performed in ZONE2.
10	9CH STEREO	The front left channel signals are output to the surround and surround back signal left channels, the front right channel signals are output to the surround and surround back signal right channels, and the in-phase component of the left and right channels is output to the center channel. Use this mode to enjoy stereo sound.

- ※ Depending on the program source being played, the effect may not be very noticeable.
In this case, try other surround modes, without worrying about their names, to create a sound field suited to your tastes.

NOTE: When playing sources recorded in monaural, the sound will be one-sided if signals are only input to one channel (left or right), so input signals to both channels. If you have a source component with only one audio output (monophonic camcorder, etc.) obtain a "Y" adaptor cable to split the mono output to two outputs, and connect to the L and R inputs.

■ Personal Memory Plus

This set is equipped with a personal memorize function that automatically memorizes the surround modes and input modes selected for the input different sources. When the input source is switched, the modes set for that source last time it was used are automatically recalled.

- ※ The surround parameters, tone control settings and playback level balance for the different output channels are memorized for each surround mode.

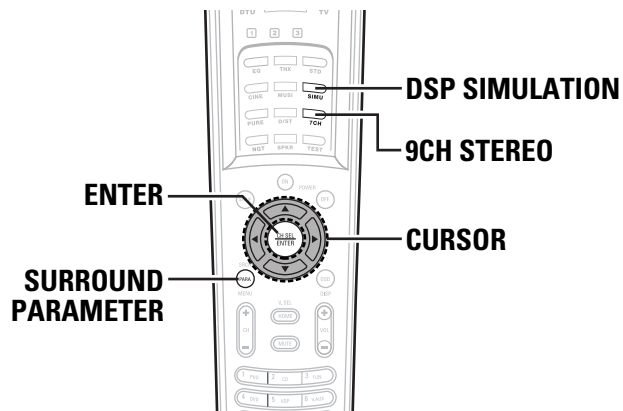
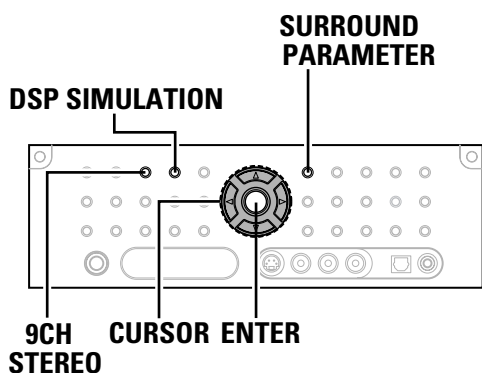

DSP surround simulation

1 Select the surround mode for each input channel.

Example: 9CH STEREO mode

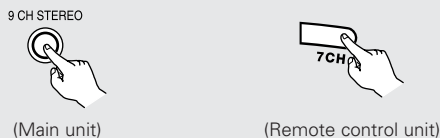

Example: DSP surround simulation mode

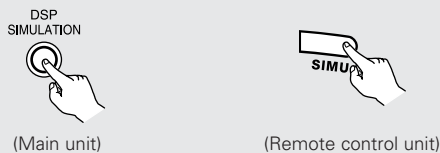

※ The surround mode switches in the following order each time the **DSP SIMULATION** button is pressed:

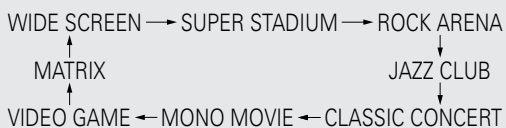

2 Press the **SURROUND PARAMETER** button.

- The surround parameter menu appears.



※ The screen for the selected surround mode appears.

3 Press the **CURSOR** Δ or ∇ button to select the various surround parameters.

4 Press the **CURSOR** \triangleleft or \triangleright button to adjust the parameters setting.

5 Press the **ENTER** or **SURROUND PARAMETER** button to complete the setting.



• The "9CH STEREO" display changes as shown below according to the surround back speaker setting.

SURROUND BACK SPEAKER	SURROUND SPEAKER SETTING	DISPLAY
ON	A + B	9CH STEREO
	A or B	7CH STEREO
OFF	A + B	7CH STEREO
	A or B	5CH STEREO

• Select "Default Yes" and press the **CURSOR** \triangleleft button to reset all the settings.

Basic Operation

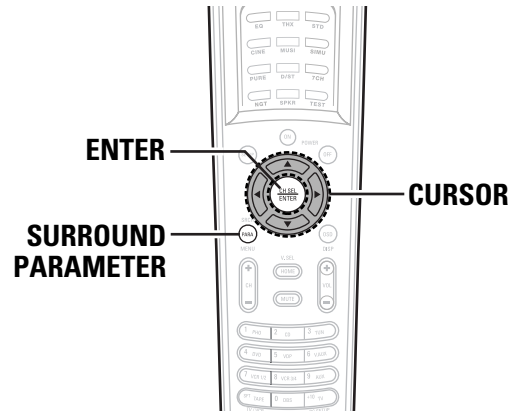
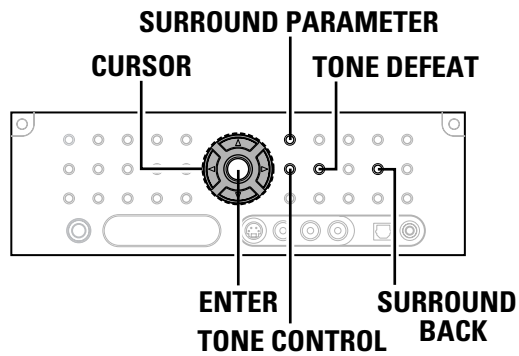

■ Surround parameters ⑥

EFFECT:

This parameter turns the effect signals with multi surround mode speaker effects on and off in the WIDE SCREEN mode. When this parameter is turned off, the SBL and SBR channel signals are equivalent to the SL and SR channels, respectively.

LEVEL:

This parameter sets the strength of the effect signals in the WIDE SCREEN mode. It can be set in 15 steps, from "1" to "15". Set this to a low level if the positioning or phase of the surround signals sounds unnatural.

SB CH OUT:

- **ON:**
Playback is conducted using the surround back speaker.
- **OFF:**
Playback is conducted without using the surround back speaker.

※ This operation can be performed directly pressing the **SURROUND BACK** button on the main unit's panel.

ROOM SIZE:

This sets the size of the sound field. There are five settings: "small", "med.s" (medium-small), "medium", "med.l" (medium-large) and "large". "small" recreates a small sound field, "large" a large sound field.

※ The "ROOM SIZE" expresses the expansion effect for the different surround modes in terms of the size of the sound field, not the actual size of the listening room.

EFFECT LEVEL:

This sets the strength of the surround effect. The level can be set in 15 steps from 1 to 15. Lower the level if the sound seems distorted.

DELAY TIME:

In the matrix mode only, the delay time can be set within the range of 0 to 300 ms.

Tone control setting

- Use the tone control setting to adjust the bass and treble as desired.
- The tone control function will not work in the PURE DIRECT, DIRECT or Home THX Cinema mode.

■ Adjusting the tone from the remote control unit

- 1 Press the SURROUND PARAMETER button.**
 - The surround parameter menu appears.

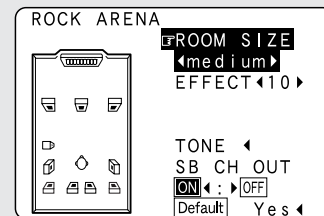

※ The screen selected surround mode appears.

- 2 Press the CURSOR Δ or ∇ button to select "TONE".**

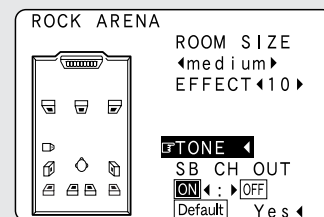

- 3 Press the CURSOR \triangleleft button.**
 - Switch to the "Total Control" screen.

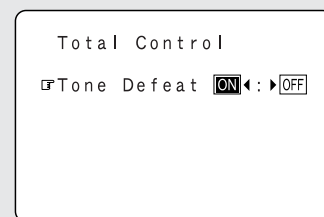

4 Press the **CURSOR** \triangleright button to select “Tone Defeat OFF”.

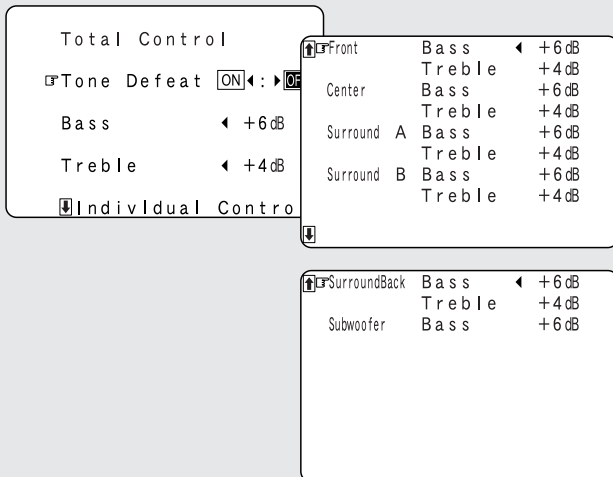

5 Press the **CURSOR** \triangle or ∇ button to select “Bass” or “Treble”.

6 Press the **CURSOR** \triangleleft or \triangleright button to set the level.

- ※ To increase the bass or treble:
The bass or treble sound can be increased to up to +6 dB in steps of 1 dB.
- ※ To decrease the bass or treble:
The bass or treble sound can be decreased up to -6 dB in steps of 1 dB.

7 Press the **ENTER** button.

- The surround parameter menu reappears.

8 Press the **ENTER** or **SURROUND PARAMETER** button to complete the setting.

■ Adjusting the tone from the main unit

1 Press the **TONE CONTROL** button.

- ※ The tone switches as follows each time the button is pressed.

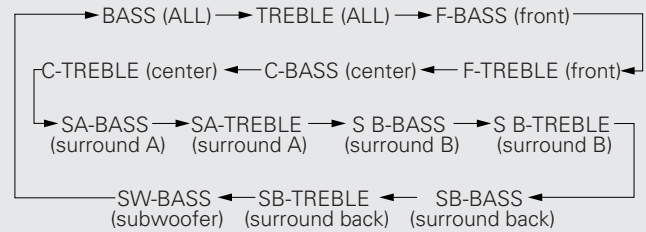

2 Press the **CURSOR** \triangleleft or \triangleright button to set the level.

- ※ To increase the bass or treble:
The bass or treble sound can be increased to up to +6 dB in steps of 1 dB.
- ※ To decrease the bass or treble:
The bass or treble sound can be decreased up to -6 dB in steps of 1 dB.

■ Tone defeat mode

- If you do not want the bass and treble to be adjusted, turn on the tone defeat mode.

Press the **TONE DEFEAT** button to turn on the “Tone Defeat” mode.

- ※ The signals do not pass through the bass and treble adjustment circuits, providing higher quality sound.

Basic Operation

FUNCTION

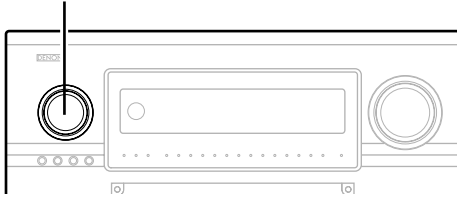

CURSOR

TUNING

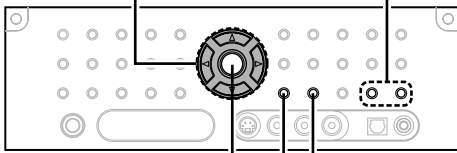

CH SEL/ENTER BAND MODE

(AMP mode)

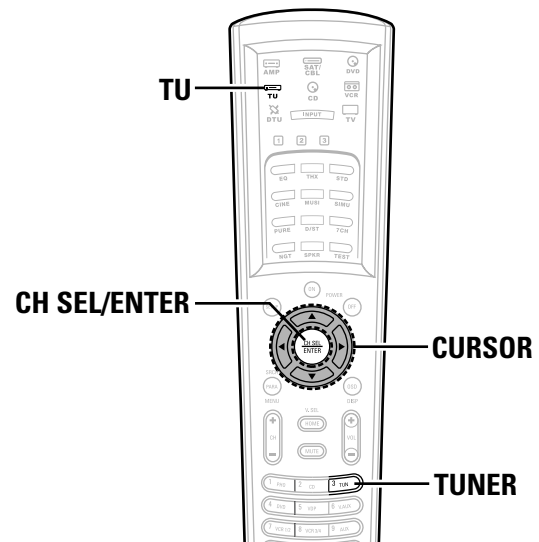

(TUNER mode)

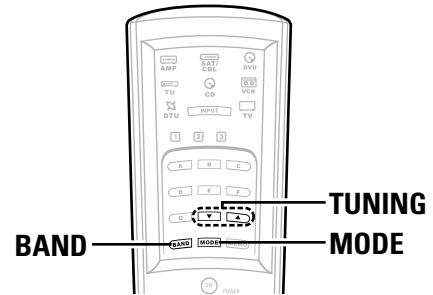

Channel Level

- You can adjust the channel level either according to the playback sources or to suit your tastes, as described below.

1 Press the **CH SEL/ENTER** button.

- The "Channel Vol." screen appears.

Channel Vol.			
FL	◀ 0.0dB	SR A	0.0dB
C	0.0dB	SR B	0.0dB
FR	0.0dB	SBR	0.0dB
SW	0.0dB	SBL	0.0dB
		SL B	0.0dB
		SL A	0.0dB
		Fader	
		FRONT	◀ : ▶ REAR

- ※ Channels which is not used are not displayed.
- ※ When the surround back speaker setting is set to "1spkr" for "Speaker Configuration" (page 140, 141), this is set to "SB".

2 Press the **CURSOR** Δ , ∇ or **CH SEL/ENTER** button to select the speaker.

- ※ The channel switches as shown below each time the **CH SEL/ENTER** button is pressed.

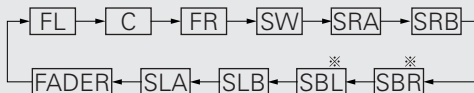

3 Press the **CURSOR** \triangleleft or \triangleright button to adjust the level.

- ※ The adjustment range for the different channels is +12.0 dB to -12.0 dB in step of 0.5 dB.
- ※ The sound from the subwoofer can be completely cut by lowering the SW (subwoofer) setting one additional from -12.0 dB (setting it to "OFF").

Fader function

- This function makes it possible to lower the volume of the front channels (FL, C and FR) or the rear channels (SL, SR, SBL and SBR) together. Use it for example to adjust the balance of the sound from each position when multi-channel music sources are played.

1 Press the CH SEL/ENTER button.

- The "Channel Vol." screen appears.

2 Press the CURSOR Δ , ∇ or CH SEL/ENTER button then select "Fader".

Channel Vol.			
FL	0.0dB	SR A	0.0dB
C	0.0dB	SR B	0.0dB
FR	0.0dB	SBR	0.0dB
SW	0.0dB	SBL	0.0dB
		SL B	0.0dB
		SL A	0.0dB
		Fader	
FRONT \blacktriangleleft : \blacktriangleright REAR			

- ※ The channel switches in the order shown below each time the CH SEL/ENTER button is pressed.

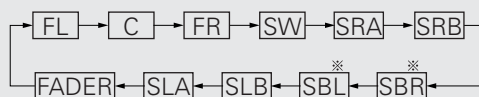

3 Press the CURSOR \triangleleft button to reduce the volume of the front channels, the CURSOR \triangleright button to reduce the volume of the rear channels.

Example: When "FRONT" is selected

Channel Vol.			
FL	- 1.0dB	SR A	0.0dB
C	- 1.0dB	SR B	0.0dB
FR	- 1.0dB	SBR	0.0dB
SW	0.0dB	SBL	0.0dB
		SL B	0.0dB
		SL A	0.0dB
		Fader	
FRONT \blacktriangleleft : \blacktriangleright REAR			

- ※ The fader function does not affect the subwoofer channel.



- The channel whose channel level is adjusted lowest can be faded to -12.0 dB using the fader function.
- If the channel levels are adjusted separately after adjusting the fader, the fader adjustment values are cleared, so adjust the fader again.

Listening to the Radio

- Check that the remote control unit is set to AMP or TUNER.

Auto tuning

1 Set the input source to "TUNER".

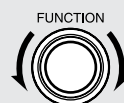

(Main unit)



(Remote control unit
in the AMP mode)

2 Press the TU (TUNER) button to select the TUNER mode.



(Remote control unit)

3 Watching the display, press the BAND button to select the desired band (AM, FM or XM).

- ※ When listening to the XM satellite Radio (see page 71).

4 Press the MODE button to set the auto tuning mode.

- The "AUTO" indicator lights.

5 Press the TUNING button.

- Automatic searching begins, then stops when a station is tuned in.



- If tuning does not stop at the desired station, use the "Manual tuning" operation.
- When in the auto tuning mode on the FM band, the "STEREO" indicator lights on the display when a stereo broadcast is tuned in. At open frequencies, the noise is muted and the "TUNED" and "STEREO" indicators turn off.

Basic Operation

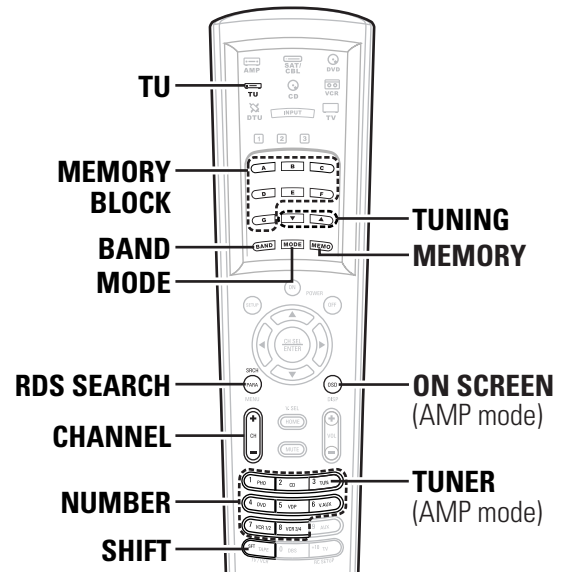
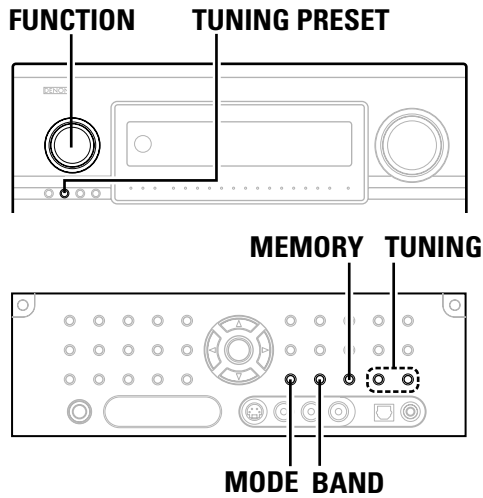

Manual tuning

- 1 Set the input source to “TUNER”.

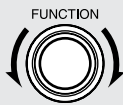

(Main unit)



(Remote control unit
in the AMP mode)

- 2 Press the **TU (TUNER)** button to select the **TUNER** mode.



(Remote control unit)

- 3 Watching the display, press the **BAND** button to select the desired band (AM, FM or XM).

※ When listening to the XM satellite Radio (☞ page 71).

- 4 Press the **MODE** button to set the manual tuning mode.

※ Check that the display’s “AUTO” indicator turns off.

- 5 Press the **TUNING** button to tune in the desired station.

※ The frequency changes continuously when the button is held in.



- When the manual tuning mode is set, FM stereo broadcasts are received in monaural and the “STEREO” indicator turns off.

Preset memory

- 1 Use the “Auto tuning” or “Manual tuning” operation to tune in the station to be preset in the memory.

- 2 Press the **TU (TUNER)** button to select the **TUNER** mode.



(Remote control unit)

- 3 Press the **MEMORY** button.

- 4 Press the **MEMORY BLOCK (A to G)** button.

※ The memory block can also be selected by pressing the **SHIFT** button.

- 5 Press the **CHANNEL** button or **NUMBER (1 to 8)** button to select the desired preset channel.

- 6 Press the **MEMORY** button again.
 - Store the station in the preset memory.



- To preset other channels, repeat steps 2 to 5. A total of 56 broadcast stations can be preset — 8 stations (channels 1 to 8) in each of blocks A to G.

Checking the preset stations

- The preset (broadcast) stations can be checked on the on screen display.

Press the **ON SCREEN** button (in the AMP mode) repeatedly until the “Tuner Preset Stations” screen appears on the on screen display.

Tuner Preset Stations	
A1FM	87.50MHz
A2FM	89.10MHz
A3FM	98.10MHz
A4FM	107.90MHz
A5FM	90.10MHz
A6FM	90.10MHz
A7FM	90.10MHz
A8FM	90.10MHz

OSD-8

Recalling preset stations

- Recalling preset stations from the remote control unit

1 Press the **MEMORY BLOCK (A to G)** button to select the memory block (A to G).

2 Watching the display, press the **CHANNEL** button or **NUMBER (1 to 8)** button to select the desired preset channel.

- Recalling preset stations from the main unit's panel

1 Press the **TUNING PRESET** button.

2 Turn the **FUNCTION** knob and select the desired preset channel.

RDS (Radio Data System)

- RDS (works only on the FM band) is a broadcasting service which allows station to send additional information along with the regular radio program signal.
- The following three types of RDS information can be received on this unit:

NOTE:

- The operations described below pressing the **RDS SEARCH** button will not function in areas in which there are no RDS broadcasts.

Program Type (PTY)

- PTY identifies the type of RDS program.
- The program types and their displays are as follows:

NEWS	News	NOSTALGA	Nostalgia
INFORM	Information	JAZZ	Jazz
SPORTS	Sports	CLASSICL	Classical
TALK	Talk	R & B	R & B
ROCK	Rock	SOFT R&B	Soft R&B
CLS ROCK	Classic rock	LANGUAGE	Language
ADLT HIT	Adult hits	REL MUSC	Religious music
SOFT RCK	Soft rock	REL TALK	Religious talk
TOP 40	Top 40	PERSNLTY	Personality
COUNTRY	Country	PUBLIC	Public
OLDIES	Oldies	COLLEGE	College
SOFT	Soft	WEATHER	Weather

Traffic Program (TP)

- TP identifies programs that carry traffic announcements.
- This allows you to easily find out the latest traffic conditions in your area before you leaving home.

Radio Text (RT)

- RT allows the RDS station to send text messages that appear on the display.

Basic Operation

FUNCTION

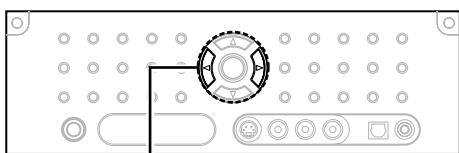
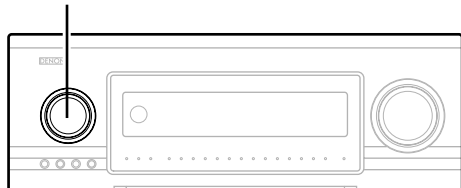

CURSOR <|>

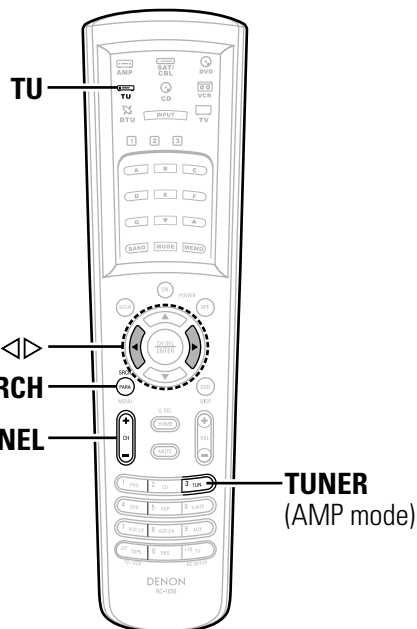

RDS search

- Use this function to automatically tune to FM stations that provide RDS service.

1 Set the input source to "TUNER".

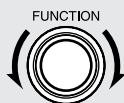

(Main unit)



(Remote control unit in the AMP mode)

2 Press the TU (TUNER) button to select the TUNER mode.



(Remote control unit)

3 Press the RDS SEARCH button until "RDS SEARCH" appears on the display.

```

[ R D S ]
New tuning system for
your convenience!
1 Push [RDS] [Search]
[RDS] -RDS station
[PTY] -Program category
[TP] -Traffic info.
[RT] -Radio Text
2 Tune by preset [Up] [Down]
CHB5 FM105.50MHz
    
```

- The main unit's display switches as follows each time the **RDS SEARCH** button is pressed.

Display



4 Press the CHANNEL button.

- Automatically begin the RDS search operation.

```

[ R D S ] [Search]
New tuning system for
your convenience!
1 Push [RDS] [Search]
[RDS] -RDS station
[PTY] -Program category
[TP] -Traffic info.
[RT] -Radio Text
2 Tune by preset [Up] [Down]
    
```

- If no RDS stations is found with above operation, all the reception band are searched.
- When a broadcast station is found, that station's name appears on the display.

5 To continue searching, repeat step 3.

- If no other RDS station is found when all the frequencies are searched, "NO RDS" is displayed.

```

[ R D S ]
New tuning system for
your convenience!
1 Push [RDS] [Search] -NO RDS-
[RDS] -RDS station
[PTY] -Program category
[TP] -Traffic info.
[RT] -Radio Text
2 Tune by preset [Up] [Down]
CHB5 FM105.50MHz
    
```

PTY search

- Use this function to find RDS stations broadcasting a designated program type (PTY).
- For a description of each program type, refer to “Program Type (PTY)”.

1 Set the input source to “TUNER”.

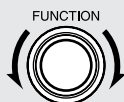

(Main unit)



(Remote control unit in the AMP mode)

2 Press the TU (TUNER) button to select the TUNER mode.



(Remote control unit)

3 Press the RDS SEARCH button until “PTY SEARCH” appears on the display.

- ※ The main unit’s display switches as follows each time the **RDS SEARCH** button is pressed.

Display



4 Watching the display, press the CURSOR ◀ or ▶ button to call out the desired program type.

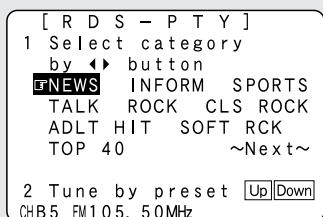

5 Press the CHANNEL button.

- Automatically begin the PTY search operation.

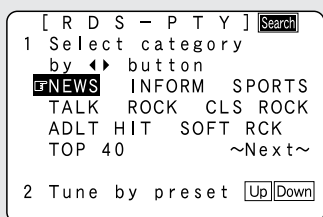

- ※ If there is no station broadcasting the designated program type with above operation, all the reception bands are searched.
- ※ The station name is displayed on the display after searching stops.

6 To continue searching, repeat step 3.

- ※ If no other station broadcasting the designated program type is found when all the frequencies are searched, “NO PROGRAMME” is displayed.

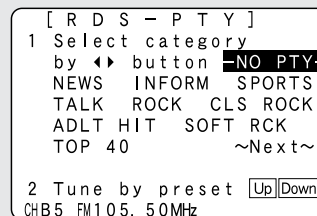

TP search

- Use this function to find RDS SEARCH stations broadcasting traffic program (TP stations).

1 Set the input source to “TUNER”.

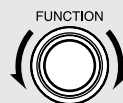

(Main unit)



(Remote control unit in the AMP mode)

2 Press the TU (TUNER) button to select the TUNER mode.



(Remote control unit)

3 Press the RDS SEARCH button until “TP SEARCH” appears on the display.

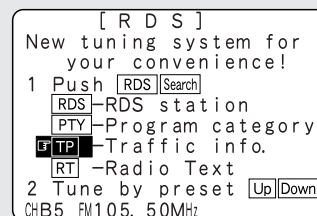

- ※ The main unit’s display switches as follows each time the **RDS SEARCH** button is pressed.

Display



Basic Operation

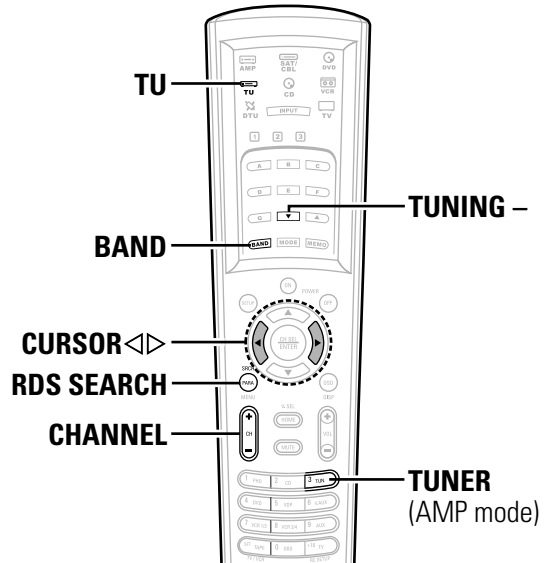
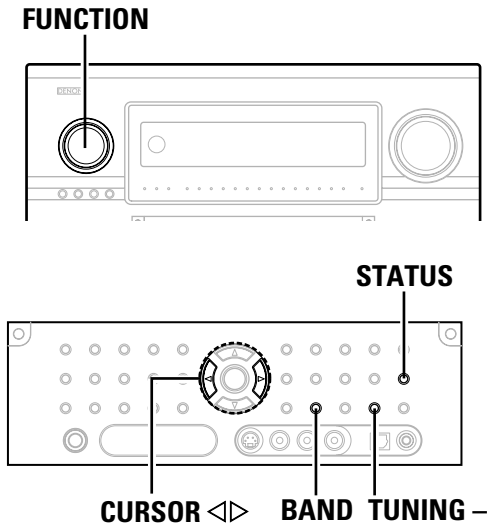

4 Press the **CHANNEL** button.

- Automatically begin the TP search operation.

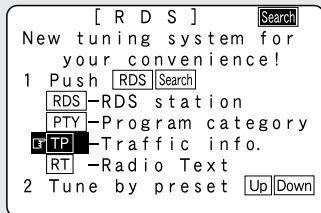

- If no TP station is found with above operation, all the reception bands are searched.
- The station name is displayed on the display after searching stops.

5 To continue searching, repeat step 3.

- If no other TP station is found when all the frequencies are searched, "NO PROGRAMME" is displayed.

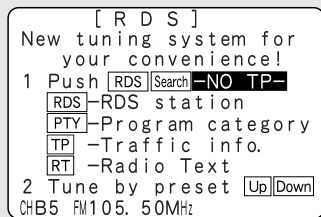

RT (Radio Text)

- "RT" appears on the display when radio text data is received.

1 Set the input source to "TUNER".

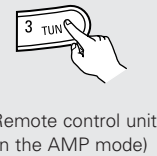
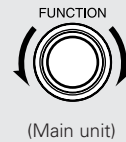

2 Press the **TU (TUNER)** button to select the TUNER mode.



(Remote control unit)

3 Press the **RDS SEARCH** button until "RT ON" appears on the display.

- The main unit's display switches as follows each time the **RDS SEARCH** button is pressed.

Display



- While receiving an RDS broadcast station, the text data broadcast from the station is displayed.
- To turn the display off, press the **CURSOR** \triangleleft or \triangleright button.
- If no text data is being broadcast, "NO TEXT DATA" is displayed.

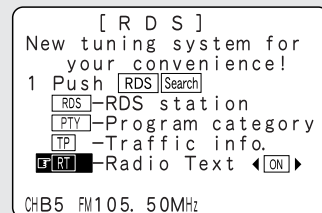

XM Satellite Radio

■ ABOUT XM SATELLITE RADIO

XM Satellite Radio offers an extraordinary variety of commercial-free music, plus the best in sports, news, talk and entertainment. XM is broadcast in superior digital audio from coast to coast. From rock to reggae, from classical to hip hop, XM has something for every music fan. XM's dedication to playing the richest selection of music is matched by its passion for live sporting events, talk radio, up-to-the-minute news, stand-up comedy, children's programming, and much more. For U.S. customers, information about XM Satellite Radio is available online at www.xmradio.com. For Canadian customers, information about XM Canada is online at www.xmradio.ca.

■ XM READY® LEGAL

Hardware and required monthly subscription sold separately. Other fees and taxes, including a one-time activation fee may apply. Subscription fee is consumer only. All fees and programming subject to change. Channels with frequent explicit language are indicated with an XL. Channel blocking is available for XM radio receivers by calling 1-800-XMRADIO (US residents) and 1-877-GET-XMSR (Canadian residents).

For a full listing of the XM commercial-free channels and advertising-supported channels, visit lineup.xmradio.com (US residents) or xmradio.ca (Canadian residents).

Subscriptions subject to Customer Agreement available at xmradio.com (US residents) and xmradio.ca (Canadian residents). Only available in the 48 contiguous United States and Canada. ©2006 XM Satellite Radio Inc. All rights reserved. All other trademarks are the property of their respective owners.

■ XM READY® SUBSCRIPTIONS

Once you have installed the XM Mini-Tuner Dock, inserted the XM Mini-Tuner, connected the XM Dock to your XM Ready® home audio system, and installed the antenna, you are ready to subscribe and begin receiving XM programming. There are three places to find your eight character XM Radio ID: on the XM Mini-Tuner, on the XM Mini-Tuner package, and on XM Channel 0. Record the Radio ID in the following eight squares for reference.



Note: The XM Radio ID does not use the letters "I", "O", "S" or "F". Activate your XM Satellite Radio service in the U.S. online at <http://activate.xmradio.com> or call 1-800-XM-RADIO (1-800-967-2346). You will need a major credit card. XM will send a signal from the satellites to activate the full channel lineup. Activation normally takes 10 to 15 minutes, but during peak busy periods you may need to keep your XM Ready home audio system on for up to an hour. When you can access the full channel lineup on your XM Ready home audio system you are done. For more information or to subscribe in Canada, visit XM on the Web at www.xmradio.ca or call XM's Listener Care at 1-877-GET-XMSR (1-877-438-9677).

Checking the XM signal strength and Radio ID

1 Set the input source to "TUNER".

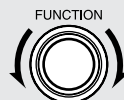

(Main unit)



(Remote control unit in the AMP mode)

2 Press the TU (TUNER) button to select the TUNER mode.

3 Watching the display, press the BAND button to select the XM mode.

4 Press the STATUS button on the main unit until "SIGNAL" is displayed.

- The display changes as shown below according to the receiving condition.

Display	Condition
GOOD	Signal strength is good
MARGINAL	Signal strength is marginal
WEAK	Signal strength is poor
NO	Loss of the signal

5 Adjust the antenna location until "SIGNAL:GOOD" is displayed.

6 Press the STATUS button until the XM channel (ex.XM001) is displayed.

7 Press the TUNING – button to select channel 0 (XM000).

- The Radio ID is displayed.



Radio ID

Basic Operation

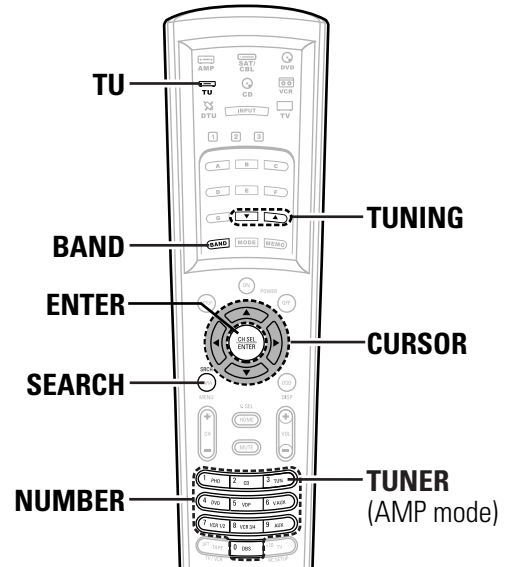
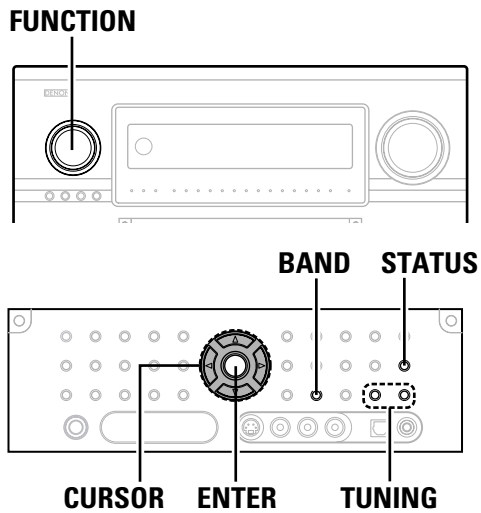

Channel selection

- 1 Set the input source to "TUNER".

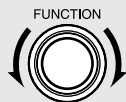

(Main unit)



(Remote control unit in the AMP mode)

- 2 Press the **TU** (TUNER) button to select the TUNER mode.

- 3 Watching the display, press the **BAND** button to select the XM mode.

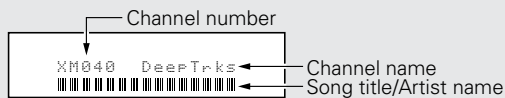

- 4 Press the **TUNING** button to reach the desired channel.

- ※ The channel changes continuously when you press and hold the **TUNING** button.
- ※ When the artist name and song title are received, they are displayed.

Category search

- 1 Press the **CURSOR** ◀ or ▶ button in the XM mode.
 - The current category name is displayed.

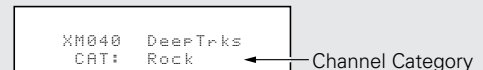

- 2 Press the **CURSOR** ◀ or ▶ button to select the category, and press the **CURSOR** ▲ or ▼ button to select the channel within the selected category.

Direct access of channels

1 Press the **SEARCH** button in the XM mode.

2 Press the **NUMBER** buttons to enter the desired channel.

※ For example, if you want to access channel 123 (ex.XM123) press the **NUMBER** buttons as shown below.

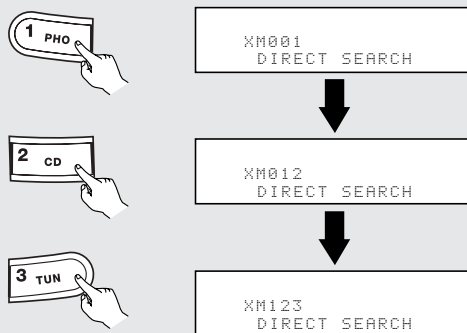

(Remote control unit)

3 Once all number have been input, press the **ENTER** button to change the channel.

※ If the next **NUMBER** button is not pressed within several seconds, the channel automatically switches to the channel number that was input.



- "LOADING" is displayed while receiving the channel or information.

```
XM040 DeepTrks
LOADING
```

- "UPDATING" is displayed while updating encryption code.

```
XM040 DeepTrks
UPDATING
```

- When the selected channel is not available, "XM- - -" is displayed.

```
XM- - -
```

- Information on the artist name, song title, category and signal level can be checked using the **STATUS** button on the main unit.
- The XM Satellite Radio channels can be preset in the same way as AM/FM band.
Please refer to "Preset memory" and "Recalling preset stations" (👉 page 66, 67).

Basic Operation

Using the Network Audio Function

- The AVR-5805CI can be connected to a network by cable to listen to Internet radio or music files stored on computers.

Internet radio function

Internet radio refers to radio programs broadcast over the Internet.

There are many stations throughout the world broadcasting Internet radio programs. These stations are of all sizes and types, some run by individuals, others by ground wave broadcast stations.

While ground wave radio stations can only be listened to within the range in which the waves reach, Internet radio can be listened to anywhere in the world.

The AVR-5805CI is equipped with the following Internet radio functions:

- Stations can be selected by genre and region.
- Up to 56 Internet radio stations can be preset.
- MP3 format Internet radio programs can be listened to.
- Your favorite radio stations can be registered by accessing the exclusive DENON Internet radio URL using a computer's browser. (The AV amplifier automatically downloads the registration settings (approximately once every other day)) (This is managed separately for each unit, so a MAC address or e-mail address must be registered.) (🔗 page 139)
 - ※ Exclusive URL : <http://www.radiodenon.com> (accessible after connection to an Internet radio station.)

■ vTuner

The AVR-5805CI's Internet radio station list uses "vTuner", a radio station database service. This database service is edited and prepared for the AVR-5805CI.

Music server function

The AVR-5805CI is equipped with a network audio playback function allowing music files stored on a computer to be played via a LAN (Local Area Network).

The AVR-5805CI's network audio playback function connects to servers using the following technologies:

- Windows Media Connect
- Windows Media DRM 10 (for network devices)

System requirements

- The preparations described below must be made in order to use the Internet radio and music server functions.

■ Broadband Internet connection

A broadband connection to the Internet is necessary in order to use the AVR-5805CI's Internet radio function.

NOTE:

- **You must have a contract with an Internet Service Provider (ISP) in order to connect to the Internet.** For instructions on connecting to the Internet, contact your ISP or a computer store.
If you already have a broadband Internet connection there is no need to take out another contract.

■ Modem

A modem is a device for exchanging signals over the Internet using a broadband connection. Some are integrated into routers. For instructions on connecting to the Internet, contact your ISP or a computer store.

■ Router

A router is a device for connecting multiple pieces of equipment (computers, the AVR-5805CI, etc.) to the Internet simultaneously.

When using the AVR-5805CI, we recommend a router equipped with the following functions:

- Built-in DHCP (Dynamic Host Configuration Protocol) server.
Function for automatically assigning the device's IP address on the LAN.
- Built-in 100BASE-TX switch
When connecting multiple devices, it is recommended to have a built-in switching hub with a speed of 100 Mbps or greater.

NOTE:

- The type of router that can be used differs for different ISPs. For details, contact your ISP or a computer store.

■ Ethernet cable (CAT-5)

The AVR-5805CI does not come with an Ethernet cable. Purchase one of the required length.

Some flat type Ethernet cables are easily affected by noise. We recommend using a normal type cable.

If the sound is broken in an environment with the electric products subject to much power noise or a noisy network environment, use a shielded type Ethernet cable. This could improve the sound.

■ **Personal Computer**

Install "Windows Media Connect" on your computer.
The required system for forming a music server is as described below.

- 1) OS (Operating System):
Windows® XP Service pack2
 - 2) Processor:
Intel Pentium®II or AMD processor, etc.
We recommend 1 GHz or greater.
 - 3) RAM:
Min. 128 MB, we recommend 256 MB or greater.
 - 4) Software:
.NET Framework 1.1
 - 5) Internet browser:
Microsoft Internet Explorer 5.01 or later
- LAN port required
 - 300 MB or greater free hard disc space required

※ Extra free space is necessary to store music files.
The following table gives an approximate estimate of the required free space.

Format	Bit rate	Per one minute	Per one hour
MP3 / WMA	128 kbps	1 MB	60 MB
	192 kbps	1.5 MB	90 MB
	256 kbps	2 MB	120 MB
	392 kbps	3 MB	180 MB
WAV (LPCM)	1400 kbps	10 MB	600 MB

■ **Others**

- When the contract with your provider is of the type by which the network settings are made manually, you must make the "Network Setup" (page 138, 139).
- The AVR-5805CI is not compatible with PPPoE. If your contract is of the PPPoE setting type, you need a PPPoE-compatible router.
- For some ISPs (Internet Service Providers), you may have to make proxy server settings in order to use the Internet radio function. If proxy server settings for connecting to the Internet have been made on the computer, make the same settings on the AVR-5805CI.
- The AVR-5805CI is designed to make the network settings automatically using the DHCP and Auto IP functions.



- No signals are output to the digital output terminals when playing copyright-protected music files.
- The AVR-5805CI is compatible with "MPEG-1 Audio Layer-3" MP3 files (with sampling frequencies of 32, 44.1 or 48 kHz). It is not compatible with "MPEG-2 Audio Layer-3", "MPEG-2.5 Audio Layer-3", "MP1" or "MP2" files.
- The AVR-5805CI is compatible with bit rates of 32 to 320 kbps for MP3 files and 48 to 192 kbps for WMA files.
- The AVR-5805CI is compatible with WMA files with sampling frequencies of 32, 44.1 or 48 kHz.
- The AVR-5805CI is compatible with MP3 ID3-Tag (Ver.2).
- The AVR-5805CI is compatible with WMA meta tags.
- With the AVR-5805CI, the folder names, file names, etc., can be displayed on the main unit's display and the OSD. Up to 95 characters can be displayed. A "." (period) is displayed in place of non-compatible characters.

■ **TU (Tuner) / DTU (Digital tuner) system buttons**

The tuner or digital tuner system buttons shown on the diagram below are used for Network Audio operations.

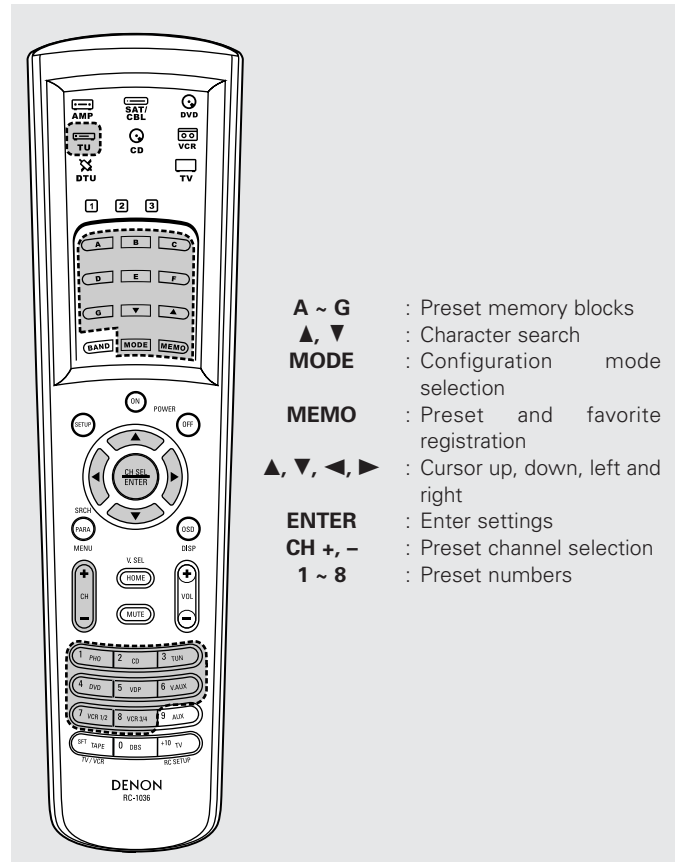

■ **Connections**

Connect one side of the Ethernet cable (CAT-5) to the ETHERNET terminal on the AVR-5805CI's rear panel, the other side to the router.

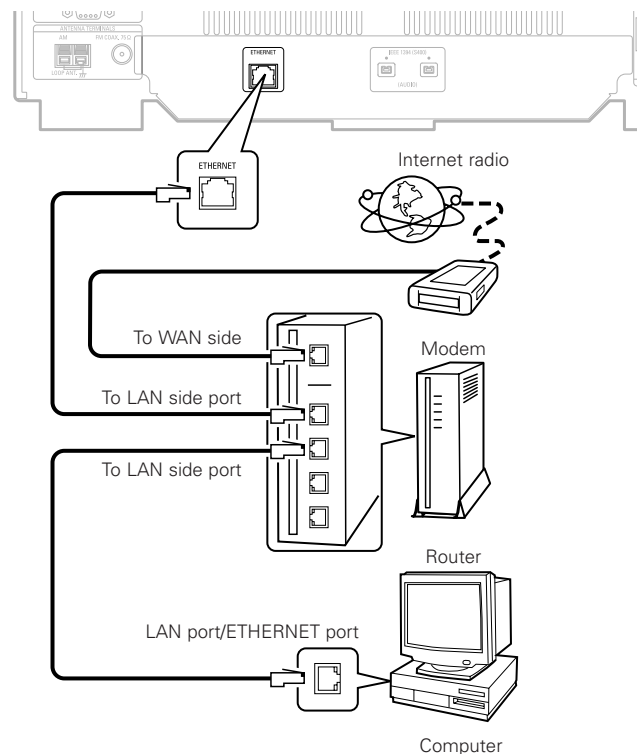

Basic Operation

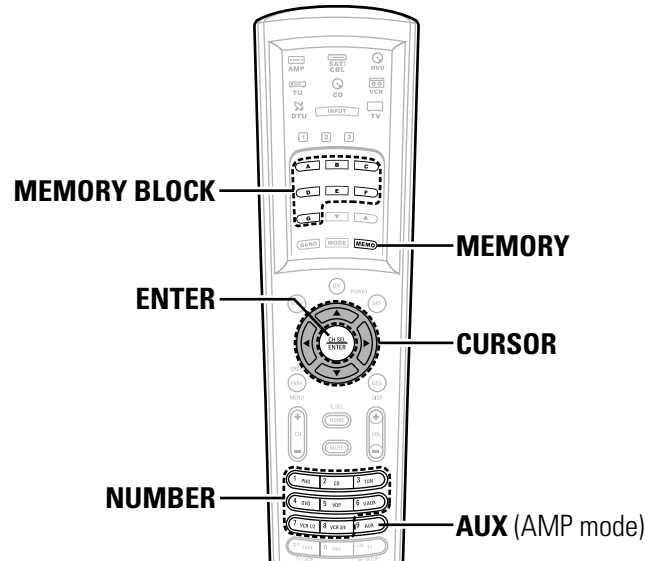
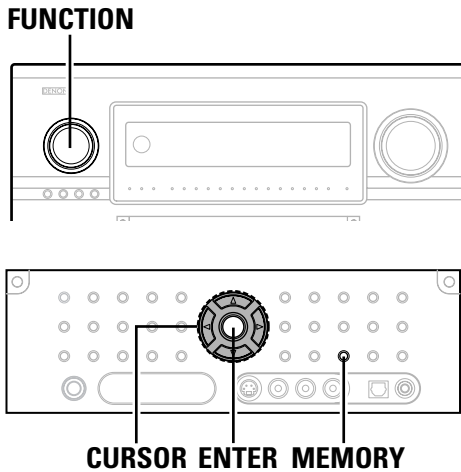

■ Network settings

When using a broadband router (DHCP function), the network settings are made automatically, so there is no need to make the settings from the setup menu. If the broadband router's DHCP function is turned off, make the "Network Setup" (☞ page 138, 139).

Listening to Internet radio

- The required system connections and settings must be made in order to listen to Internet radio. "Update?" appears on the display when connecting to an Internet radio station for the first time.

1 Either turn the **FUNCTION** knob or press the **AUX** button to select "NetAudio" (AMP mode).

- The "Network Audio" menu appears.

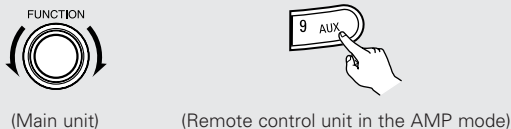

2 Press the **CURSOR** \triangle or ∇ button to select "Internet Radio", then press the **ENTER** or **CURSOR** \triangleright button.

- The initial screen when not connected to the Internet is displayed.

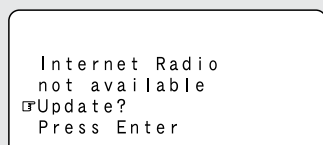

3 Connecting to an Internet radio station for the first time:

Press the **ENTER** or **CURSOR** \triangleright button.

- The update screen appears.

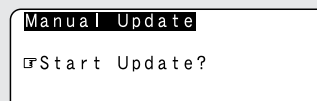

4 Press the **ENTER** or **CURSOR** \triangleright button once again.

- The latest list of radio stations is downloaded from the vTuner site. (Several minutes are required for this download.)

5 Press the **CURSOR** \triangle or ∇ button to select the desired setting item, then press the **ENTER** or **CURSOR** \triangleright button.

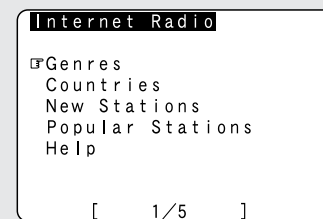

- Finally, the list of Internet radio stations is displayed and those that can be played are indicated by the "*" mark in front of them.

6 Press the **CURSOR** \triangle or ∇ button to select the desired radio station, then press the **ENTER** or **CURSOR** \triangleright button.

- Connection starts, and the station starts playing once the buffer reaches "100%".
- During playback, press the **ENTER** button once to pause playback, then press **ENTER** button again to resume playback.
- If the **ENTER** button is pressed and held in for more than two seconds when in the play or pause mode, playback stops and the previous menu window reappears.



- There are many Internet radio stations on the Internet. The programs they broadcast and their bit rates vary widely. Generally, the higher the bit rate, the higher the sound quality, but streamed music or sound may be broken if the communication lines or servers are busy. Inversely, programs with low bit rates have lower sound quality but tend to be more stable.
- “Server Full” or “Connection Down” is displayed if the station is congested or if it is not broadcasting.
- The time for which the on screen display is displayed can be set at “Setting the On Screen Display” (🔧 page 115).

Presetting (registering) Internet radio stations

- There are two ways to register stations: by presetting them or by storing them in your favorites.
- Stations that are preset can be tuned in directly from the remote control unit.

1 Press the **MEMORY** button while playing the Internet radio station you want to register.

- The registration menu appears.



2 Press the **CURSOR** Δ or ∇ button to select “Preset”, then press the **ENTER** or **CURSOR** \triangleright button.

- The preset registration screen appears.

3 Press a **MEMORY BLOCK (A ~ G)** button, then press a **NUMBER (1 ~ 8)** button to register the station at the desired preset channel.

- This completes registration.

- ※ If no button is operated for approximately ten seconds, the regular display reappears.
- ※ Registered presettings can be checked on the on screen display.
The presettings can only be displayed with the on screen display when the “NetAudio” function is selected.

NOTE:

- Registered presettings are deleted when they are overwritten.

■ Listening to preset Internet radio stations

When the “NetAudio” function is selected, press a **MEMORY BLOCK (A ~ G)** button, then press a **NUMBER (1 ~ 8)** button.

- The connection is made automatically and playback starts.

Registering Internet radio stations in your favorites

- Your favorites are listed at the top of the menu screen, so registered stations can be tuned in easily.

1 Press the **MEMORY** button while playing the Internet radio station you want to register.

- The registration menu appears.



2 Press the **CURSOR** Δ or ∇ button to select “Favorites”, then press the **ENTER** or **CURSOR** \triangleright button.

- The favorites registration screen appears.

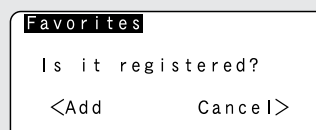

3 Press the **CURSOR** \triangleleft button to register the station.

- ※ To cancel without registering, press the **CURSOR** \triangleright button.

Basic Operation

FUNCTION

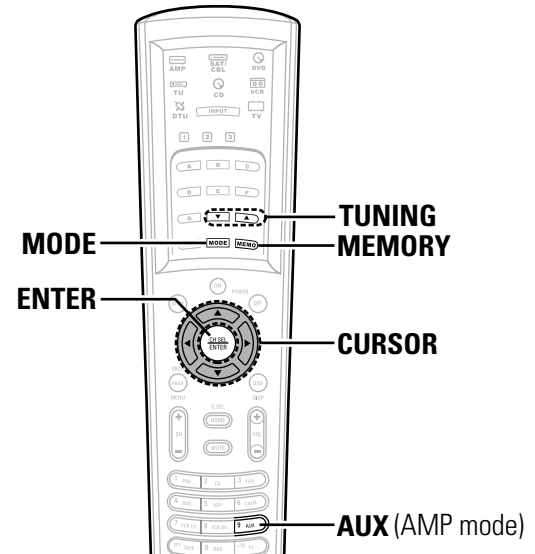
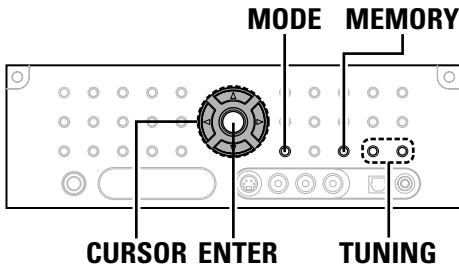
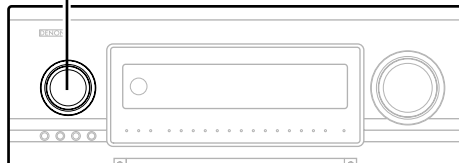

■ Listening to Internet radio stations registered in your favorites

1 When the “NetAudio” function is selected, press the **CURSOR** \triangle or ∇ button to select “Favorites”, then press the **ENTER** or **CURSOR** \triangleright button.

- The Internet radio stations registered in your favorites are displayed.

2 Press the **CURSOR** \triangle or ∇ button to select the desired radio station, then press the **ENTER** or **CURSOR** \triangleright button.

- Playback starts.

■ Deleting radio stations from your favorites

1 At the screen on which the Internet radio stations registered in your favorites are displayed, press the **CURSOR** \triangle or ∇ button to choose the radio station you want to delete, then press the **MEMORY** button.

- The delete screen appears.

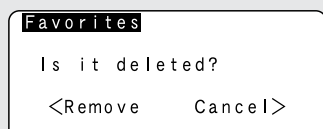

2 Press the **CURSOR** \triangleleft button to delete the station.

- ※ To cancel without deleting, press the **CURSOR** \triangleright button.

Character search function (searching by first letter)

- The character search function (searching by first letter) can be used to select the desired item from the menu screen displaying the list of Internet radio stations or music files stored on the computer.

1 While the menu screen is displayed, press the **TUNING** button.

- The character search screen appears.

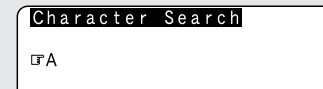

2 Press the **TUNING** button to select the first letter of the item you want to search for.

- After several seconds, the menu screen is displayed with the cursor set to the item starting with the letter selected in step 2.

- ※ If there is more than one item starting with the letter selected in step 2, the items are displayed in alphabetical order.

Updating the list of radio stations

1 Press the **MODE** button to select the configuration mode, then press the **ENTER** or **CURSOR** \triangleright button.

- The settings screen appears.



2 Press the **CURSOR** \triangle or ∇ button to select “Automatic Update” or “Manual Update”, then press the **ENTER** or **CURSOR** \triangleright button.

- The update screen appears.

※ Select “Radio List Version” to display the current version.

3 When “Automatic Update” is selected: Press the **ENTER** or **CURSOR** \triangleright button to select “Yes”.

- The list of radio stations is updated approximately once every other day.

3 When “Manual Update” is selected: Press the **ENTER** or **CURSOR** \triangleright button.

- 2 • The list of radio stations is updated this one time.



- When “Yes” is set for “Automatic Update”, set “Power Saving” in the “Network Setup” to “OFF” (page 139). When used with “Power Saving” set to “ON”, we recommend performing the “Manual Update” procedure periodically (about once a week).

Playing music files stored on the computer (music server)

- The necessary system connections and settings must be made in order to play music files.
- This procedure is used to play music files (in WMA, MP3 and WAV format) stored on computers (music servers) connected to the AVR-5805CI via the network.
- The computer’s server program must be launched before using this function. For details, refer to the server program’s operating instructions.

1 Either turn the **FUNCTION** knob or press the **AUX** button to select “NetAudio” (AMP mode).

- The “Network Audio” menu appears.

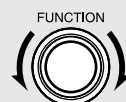

(Main unit)



(Remote control unit in the AMP mode)

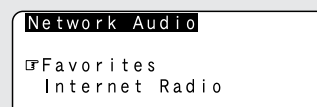

- ※ The host names of the computer(s) (music server(s)) on the network are displayed.

2 Press the **CURSOR** \triangle or ∇ button to select the host name of the computer (music server) on which the music file you want to play is located, then press the **ENTER** or **CURSOR** \triangleright button.

3 Press the **CURSOR** \triangle or ∇ button to select the search item or the desired folder, then press the **ENTER** or **CURSOR** \triangleright button.

- ※ Playable music files are indicated by the “*” mark in front of them.

4 Press the **CURSOR** \triangle or ∇ button to select the music file, then press the **ENTER** or **CURSOR** \triangleright button.

- Connection starts, and playback starts once the buffer reaches “100%”.
- ※ Press the **CURSOR** ∇ button to select the next file, the **CURSOR** \triangle button to select the previous file.
- ※ During playback, press the **ENTER** button once to pause playback, then press the **ENTER** button again to resume playback.
- ※ If the **ENTER** button is pressed and held in for more than 2 seconds when in the play or pause mode, playback stops and the previous menu screen reappears.

Basic Operation

■ Playing music files that have been preset or registered in your favorites

- The same operations as for Internet radio stations can be used to preset music files or register them in your favorites and play them.

NOTE:

- Registered presettings are deleted when they are overwritten.
- When the operations describe below are performed, the music server database is updated and it may no longer be possible to play the music files that have been preset or registered in your favorites:
 - When the music server is stopped and restarted.
 - When music files are deleted from or added to the music server.
- When using an ESCIENT server, place "ESCIENT" before the server name.

Operating the AVR-5805CI using a browser

- Internet Explorer can be used on the computer connected to the AVR-5805CI over the network to operate the AVR-5805CI.
- Check the AVR-5805CI's IP address (👉 page 138) beforehand and input this IP address in Internet Explorer to display the AVR-5805CI's control panel.
- Operate in the same way as with normal Internet browsing to control the AVR-5805CI.

■ Examples of web control operation screens

The settings of the setup items are the same as with normal operations. Refer to "System Setup". Below are some examples of operation screens.

Function selection screen

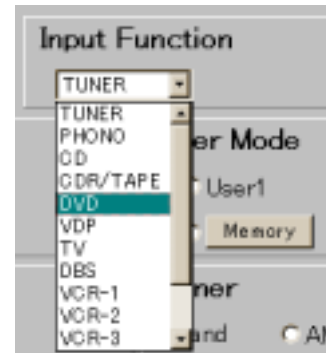

Surround mode selection screen

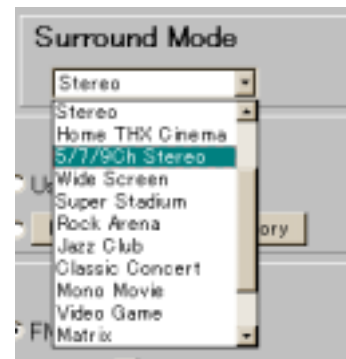

Volume control screen

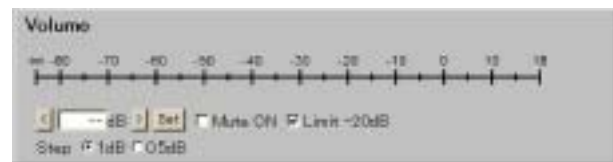

NOTE:

- To use this function, set "Standby Mode Power Saving" at "Network Option" under "Network Setup" to "OFF" (👉 page 139).

Advanced Operation

Remote control unit

- With the attached remote control unit, the display changes according to the mode being operated.

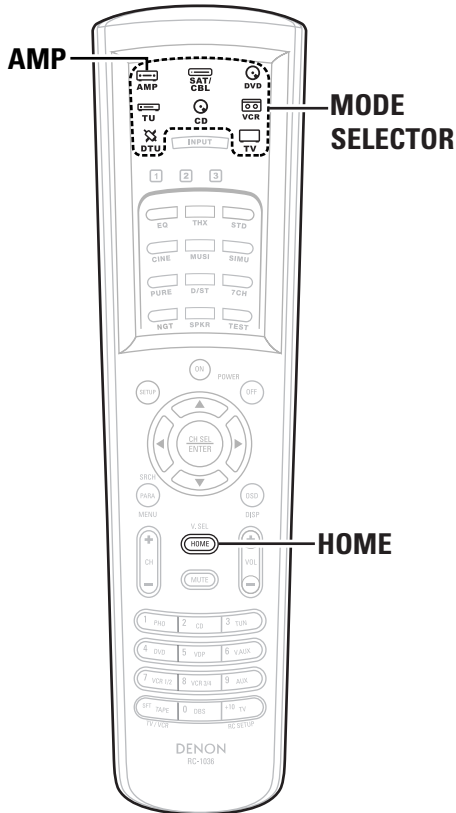

Operating DENON audio components

1 Press the **MODE SELECTOR** button for the device to be operated.

- The indicator of the device to be operated blinks.

: AMP / ZONE2 / ZONE3 / ZONE4 / SYSTEM CALL	: CD / CDR
: TUNER	: DVD / DVDR
: DIGITAL TUNER	: VCR / TAPE
: SATELLITE / CABLE	: TV

- ※ This function switches as shown below each time one of the **AMP** button is pressed.

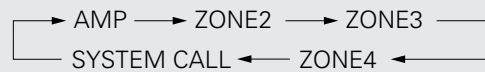

2 Operate the DENON audio component (CD, TAPE, TUNER).

- ※ For details, refer to the component's operating instructions.



- It may not be possible to use some of the buttons, depending on the model and age of your equipment.
- When a remote control code is sent, the icon for the mode of the device to which that code belongs flashes.
- The **HOME** button is used to return to the "AMP" ("AMP", "ZONE2", "ZONE3", "ZONE4" or "SYSTEM CALL") mode when in any mode other than "AMP".

Advanced Operation

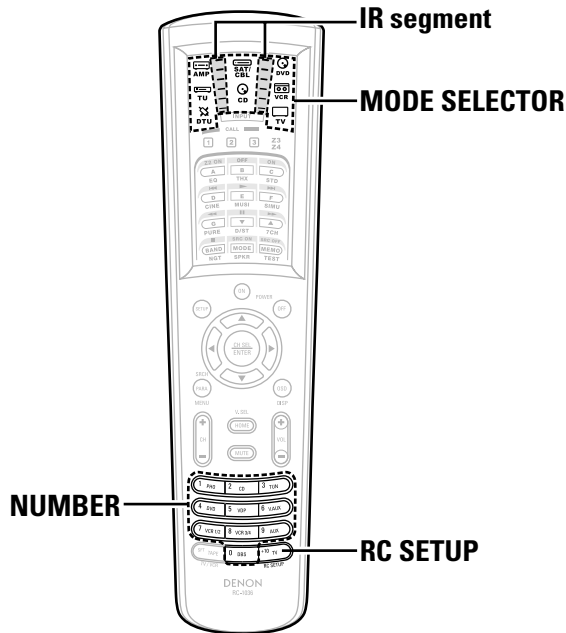

- There may be several preset codes for some brands. If the remote control unit does not work properly with one code, try inputting another code.
- Buttons that have been learned have priority over the signals set with the preset memory function. If a learned button setting is not needed, please erase it (👉 page 86).

Operating a component stored in the preset memory

- 1 Press the MODE SELECTOR button for the device to be operated.**
 - The indicator of the device to be operated blinks.
- 2 Operate the component.**
 - For details, refer to the component's operating instructions.

Setting the preset memory function

- The various devices can be operated by setting the preset memory on the attached remote control unit. For some models the remote control unit or the device may not operate properly. In this case, use the learning function (👉 page 84) to store your device's remote control signals in the attached remote control unit.

1 Press the MODE SELECTOR button for the device to be set in the preset memory.

- Presetting is not possible for the AMP, ZONE2, ZONE3, ZONE4, TUNER and SYSTEM CALL modes.

2 Press and hold the RC SETUP button for at least 3 seconds.

- The IR segment blinks twice and the input mode is set.

3 Input the (5-digit) number for the brand of the device to be set in the preset memory, as shown on the list of preset codes (👉 End of this manual).

- The IR segment blinks twice when the memory is set.
- When a preset code is transmitted, the mode indicator for the device to which that code belongs blinks.

- The input mode is canceled if no operation is performed for 10 seconds.

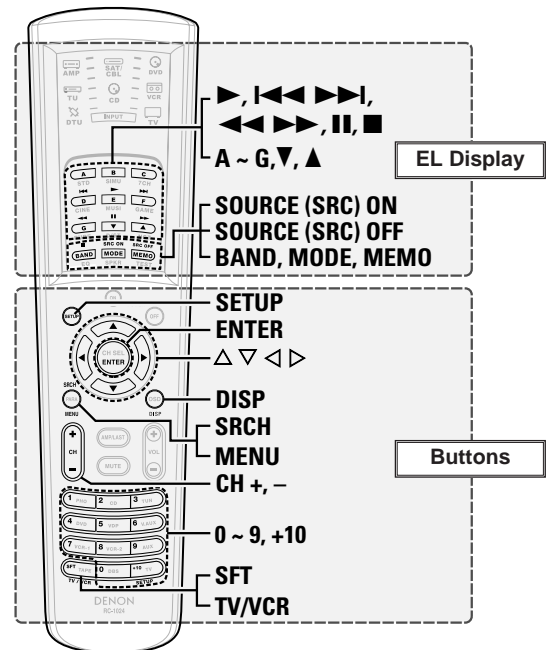

■ Functions of buttons for the different devices

Device operated	CD player or CD recorder	Video deck	Tape deck	Tuner	DVD player or DVD recorder	TV (Monitor)	Satellite tuner or Cable TV
EL Display							
MODE SELECTOR	CD	VCR		TU	DVD	TV	SAT/CBL
▶	Play	Play	Play	–	Play	–	–
◀◀ ▶▶	Auto search (to beginning of track)	Auto search (to beginning of track)	Auto search (to beginning of track)	–	Auto search (to beginning of track)	–	–
◀▶ ▶▶	Manual search (forward / reverse)	Manual search (forward / reverse)	Manual search (forward / reverse)	–	Manual search (forward / reverse)	–	–
⏸	Pause	Pause	Pause	–	Pause	–	–
■	Stop	Stop	Stop	–	Stop	–	–
SOURCE ON	–	Power on	–	–	Power on	Power on	Power on
SOURCE OFF	–	Power off	–	–	Power off	Power off	Power off
A ~ G	–	–	–	Preset memory block	–	–	–
▲ ▼	–	–	–	Tuning	–	–	–
BAND	–	–	–	AM/FM/XM switching	–	–	–
MODE	–	–	–	Auto/Manual switching	–	–	–
MEMO	–	–	–	Preset memory	–	–	–
Buttons							
SETUP	–	Setup	–	–	Setup	Setup	Setup
ENTER	–	Enter	–	–	Enter	Enter	Enter
△ ▽ ◀ ▶	–	Cursor operation	–	–	Cursor operation	Cursor operation	Cursor operation
CH + –	–	Station selection	–	Preset channel selection	Station selection	Station selection	Station selection
SRCH	–	–	–	RDS search/ XM direct search	–	–	–
MENU	–	Menu	–	–	Menu	Menu	Menu
DISP	–	Guide	–	–	Display selection	Guide	–
SFT	–	–	–	Preset memory block selection	–	–	–
0 ~ 9, +10	Track selection	Station selection	Track selection	Preset station selection (0 ~ 8)/ XM channel selection (0 ~ 9)	Number input/station selection	Station selection	Station selection
TV / VCR	–	–	–	–	–	Input mode selection	–
Default setting (preset code)	DENON CD (31867)	HITACHI VCR (20000)	–	–	DENON DVD (41470)	HITACHI TV (11145)	RCA SAT (00392)
Special remarks	①	①	①	–	①, ②	③	①, ③

Special remarks:

- ① It is only possible to set the preset memory for one device per mode.
- ② Note that the function names of the DVD buttons on the remote control unit may differ for some brands. Check beforehand.
- ③ The CD, VCR or DVD buttons can be assigned to a TV or satellite tuner (or cable TV) (▶ page 85).

Advanced Operation

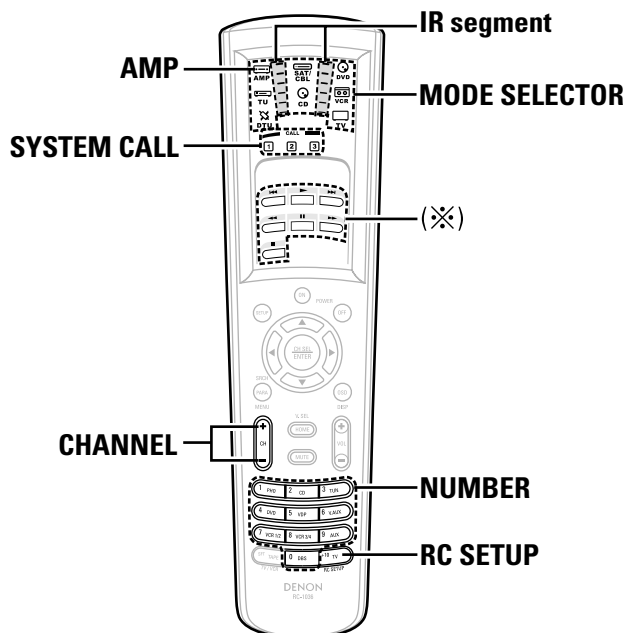

Setting the learning function

- If your AV device is a brand other than DENON or if operation is not possible using the preset memory function, the signals of a remote control unit of that device can be stored in the AVR-5805CI's remote control unit.
- For some remote control units, it may not be possible to learn the signals or the device may not operate properly after the signals are learnt. In this case, use the remote control unit of that device.

1 Press and hold the **RC SETUP** button for at least 3 seconds.

- The IR segment blinks twice.

2 Press the **9, 7, 5** button (9 → 7 → 5) in that order.

- The IR segment blinks twice and the learning mode is set.

3 Press the **MODE SELECTOR** button for the device to be operated.

- ※ Learning is not possible for the AMP, ZONE2, ZONE3, ZONE4 and SYSTEM CALL modes.

4 Press the button to be set.

- The display will go off and the unit will enter the learning standby mode.
- ※ If a button that cannot be learnt is pressed, the IR segment lights and the setting is canceled.
- ※ Cannot be set at the **HOME** button.

5 Point the remote control units straight at each other and press and hold in the button on the other remote control unit to be learnt on the AVR-5805CI's remote control unit.

- The display turns on again and the IR segment blinks twice to indicate that the code is successfully captured.

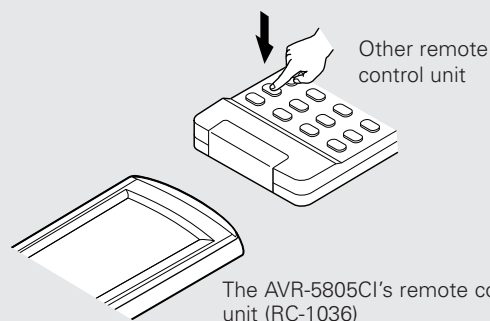

- ※ Other buttons can be learnt by repeating steps 4 and 5.
- ※ The mode can be switched by pressing a **MODE SELECTOR** button.
- ※ If the IR segment displays one long blink, a learning error has occurred. Try repeating this step again until a successful capture occurs.

6 Press and hold the **RC SETUP** button for at least 3 seconds.

- The IR segment blinks twice and the setting is completed.



- To cancel the learning setup mode, press and hold the **RC SETUP** button for at least 3 seconds.

NOTE:

- Do not try to learn anything to the **RC SETUP** button.

Using the system call function

- A series of operations can be registered at a single button.
- This function makes it possible to for example turn the amplifier's power on, select the input source, turn the monitor power's on, turn the source device's power on and start playback, all by pressing a single button once.
- Up to 32 signals each can be stored at the **SYSTEM CALL** button (**1, 2** or **3**).

■ Registering

1 Press and hold the **RC SETUP** button for at least 3 seconds.

- The IR segment blinks twice.

2 Press the **9, 7, 8** button (9 → 7 → 8) in that order.

- The IR segment blinks twice and the system call registration mode is set.

3 Press the **SYSTEM CALL** button (1, 2 or 3) for which you want to register the operations.

4 Press the buttons you want to register in the order of the operations to be performed.

Example: Press the **ON** button.

↓
Press the **CD** button of the **MODE SELECTOR** button.

↓
Press the **▶** button.

- ※ The mode can be switched by pressing a **MODE SELECTOR** button.

5 Repeat steps 3, 4 to register the desired buttons.

6 Press and hold the **RC SETUP** button for at least 3 seconds.

- The IR segment blinks twice and the setting is completed.

■ Operating

1 Press the **AMP** button to select “SYSTEM CALL”.

2 Press the **SYSTEM CALL** button (1, 2 or 3) at which the operation are registered

- The stored signals are transmitted successively.

Setting the punch through function

- CD, DVD or VCR mode buttons can be assigned to unused TV and SAT/CBL mode buttons.
- For example, when DVD mode operations are assigned to TV mode buttons, the DVD mode can be operated while in the TV mode.

1 Press and hold the **RC SETUP** button for at least 3 seconds.

- The IR segment blinks twice.

2 Press the **9, 8, 4** button (9 → 8 → 4) in that order.

- The IR segment blinks twice and the punch through setting mode is set.

3 Press the **MODE SELECTOR** button for the device to be punched through (CD, DVD or VCR).

4 Press the button to be punched through (▶, ■, ◀◀, ▶▶, ◀◀◀, ▶▶▶ or ||).

5 Press the **MODE SELECTOR** button for the device to be punched through (TV or SAT/CBL).

6 Press and hold the **RC SETUP** button for at least 3 seconds.

- The IR segment blinks twice and the setting is completed.

Setting the back light's lighting time

1 Press and hold the **RC SETUP** button for at least 3 seconds

- The IR segment blinks twice.

2 Press the **9, 7, 3** button (9 → 7 → 3) in that order.

- The IR segment blinks twice and the backlight lighting time setting mode is set.

3 Press the **NUMBER** button of (1 to 5) you want to set the lighting time.

- The IR segment blinks twice.

Lighting time: 1 : 5 sec
2 : 10 sec (factory default)
3 : 15 sec
4 : 20 sec
5 : 25 sec

Setting the brightness

- The brightness of the display can be adjusted in 5 steps (Default : level 3).
- First set the auto brightness adjustment setting to “OFF”.

1 Press and hold the **RC SETUP** button for at least 3 seconds.

- The IR segment blinks twice.

2 Press the **CHANNEL** button.

- Press the + button to increase the brightness 1 step.
- Press the – button to decrease the brightness 1 step.

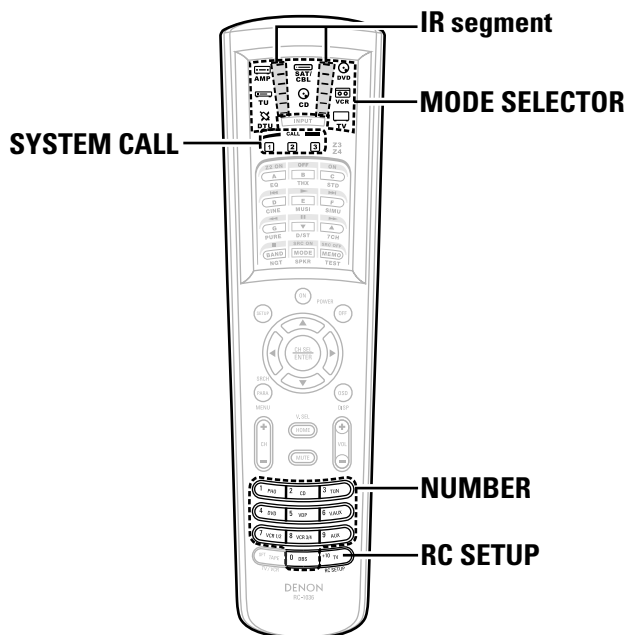

Resetting the remote control unit

Resetting the learning function

■ Resetting for individual buttons

- 1** Press and hold the **RC SETUP** button for at least 3 seconds.
 - The IR segment blinks twice.
- 2** Press the **9, 7, 6** button (9 → 7 → 6) in that order.
 - The IR segment blinks twice and the learning function resetting mode is set.
- 3** Press the **MODE SELECTOR** button for the device to be reset.
- 4** Press the button to be reset twice.
 - The IR segment blinks twice.

■ Resetting for individual devices

- 1** Press and hold the **RC SETUP** button for at least 3 seconds.
 - The IR segment blinks twice.
- 2** Press the **9, 7, 6** button (9 → 7 → 6) in that order.
 - The IR segment blinks twice and the learning function resetting mode is set.
- 3** Press the **MODE SELECTOR** button for the device to be reset twice.
 - The IR segment blinks twice.

Resetting the system call function

- 1** Press and hold the **RC SETUP** button for at least 3 seconds.
 - The IR segment blinks twice.
- 2** Press the **9, 7, 8** button (9 → 7 → 8) in that order.
 - The IR segment blinks twice and the system call resetting mode is set.
- 3** Press the **SYSTEM CALL** button (1, 2 or 3) you want to reset.
- 4** Press and hold the **RC SETUP** button for at least 3 seconds.
 - The IR segment blinks twice.

Resetting the punch through function

- 1** Press the **MODE SELECTOR** button for the device to be reset (TV or SAT/CBL).
- 2** Press and hold the **RC SETUP** button for at least 3 seconds.
 - The IR segment blinks twice.
- 3** Press the **9, 8, 4** button (9 → 8 → 4) in that order.
 - The IR segment blinks twice and the punch through function resetting mode is set.
- 4** Press and hold the **RC SETUP** button for at least 3 seconds.
 - The IR segment blinks twice.

Resetting all the settings

- 1** Press and hold the **RC SETUP** button for at least 3 seconds.
 - The IR segment blinks twice.
- 2** Press the **9, 8, 1** button (9 → 8 → 1) in that order.
 - The IR segment blinks 4 times and the learning function resetting mode is set.
 - Clear the entire system memory, which will restore the remote control unit to the factory default settings.

Multi zone music entertainment system

- When the outputs of the “ZONE2 (ZONE3, ZONE4)” OUT terminals are wired and connected to power amplifiers installed in other rooms, different sources can be played in rooms other than the MAIN ZONE in which this unit and the playback devices are installed. (Refer to ZONE2 (ZONE3, ZONE4) on the diagram below.)
- Settings can be made at “Power Amp Assign” in the “System Setup Menu” so that the same source as the ZONE2 (ZONE3, ZONE4) pre-out terminals can be played from the speakers connected to the ZONE2 (ZONE3, ZONE4) speaker terminals (🔗 page 129 ~ 133).
- ※ To control playback devices other than the ones above, either use that device’s remote control unit or preset a separately sold programmable remote control unit.



- For the AUDIO output, use high quality pin-plug cords and wire in such a way that there is no humming or noise.
- For instructions on installation and operation of separately sold devices, refer to the devices’ operating instructions.
- Video signals are output from the ZONE3 video output terminals even when the power of ZONE3 is turned off.

ZONE2 playback

- The AVR-5805CI is equipped with pre-out terminals for which the volume is adjustable and video output terminals (composite, S-Video and component) as the ZONE2 output terminals.
- A separately sold power amplifier or premain amplifier can be connected to enjoy ZONE2 playback.
- The AVR-5805CI ZONE2 monitor output is equipped with a video conversion function, so connect the ZONE2 monitor output terminal with a video, S-Video or component video cable. For details, see “The video conversion function” (🔗 page 28).

Advanced Operation

■ ZONE2 5.1 channel system

- 5.1 channel playback is possible in ZONE2 if "5.1CH" is selected for the ZONE2 playback channel setting at "Channel Setup" (page 126 ~ 128) in the System Setup Menu.
(Default setting of ZONE2 channel is "5.1CH".)

--- ZONE2 VIDEO signal cable

--- MULTI SOURCE AUDIO signal cable

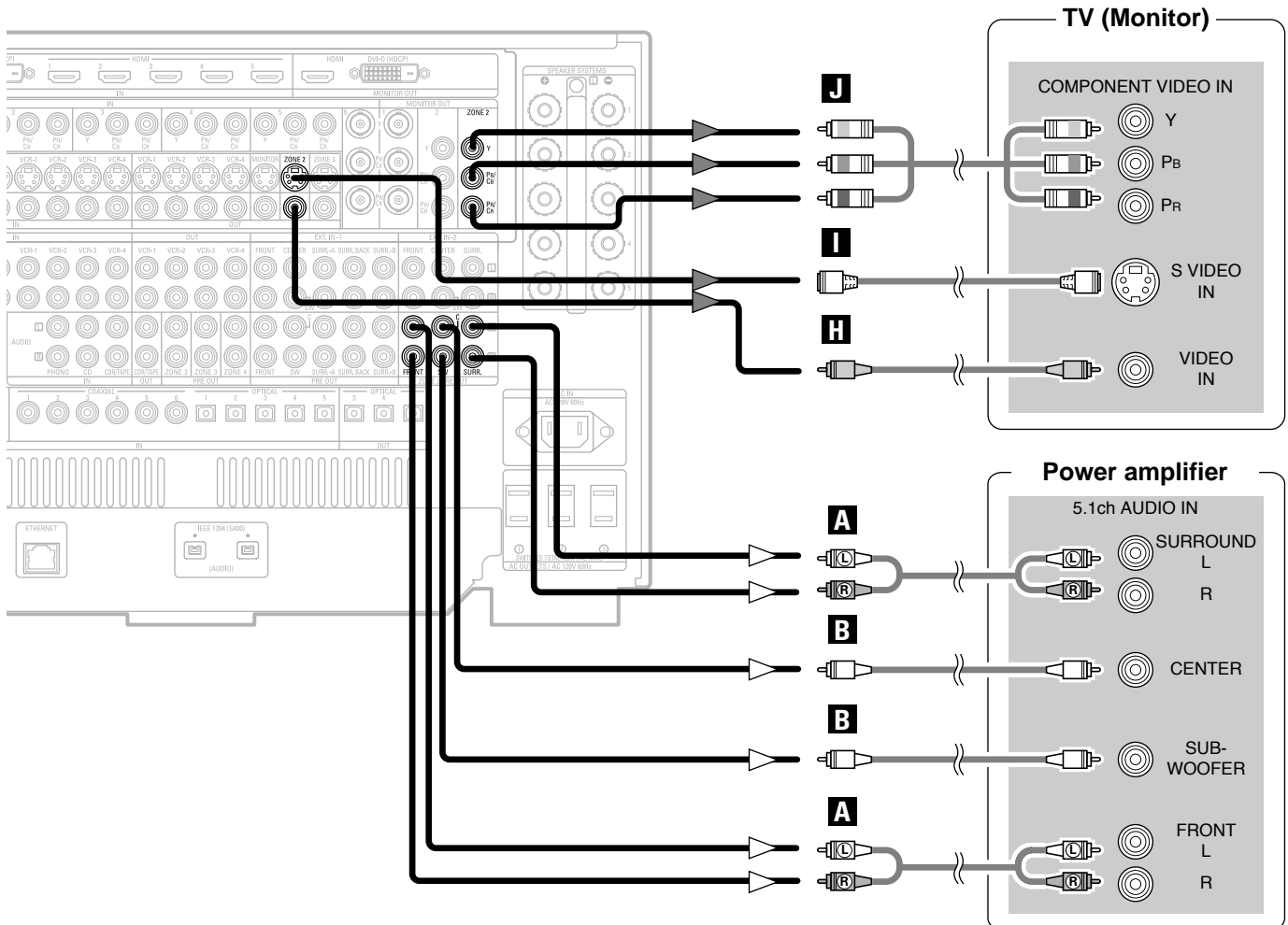
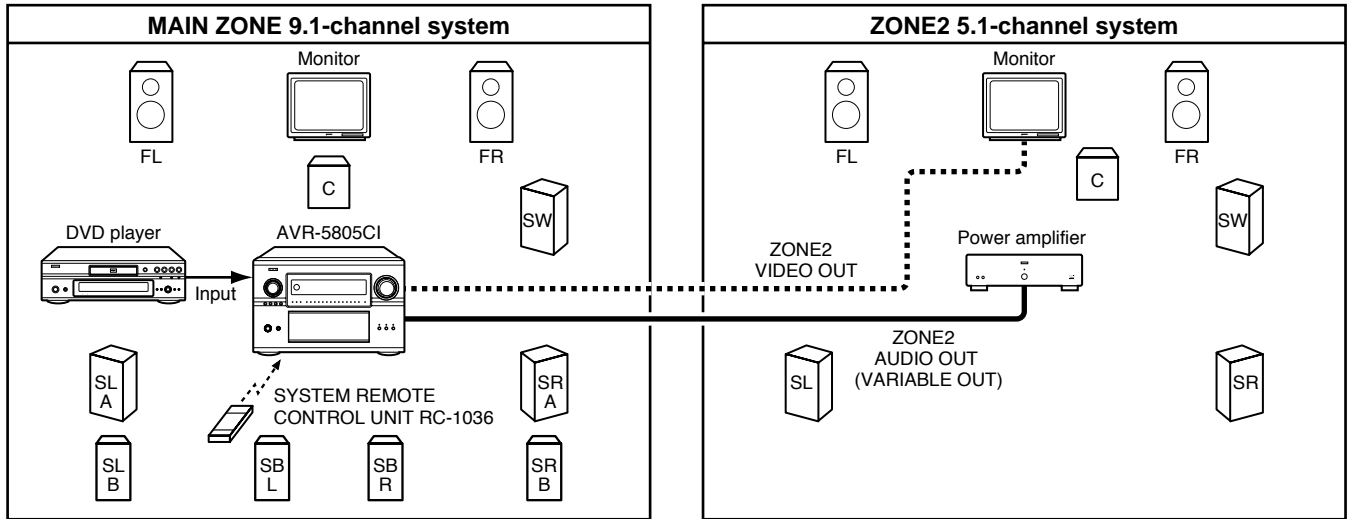

■ ZONE2 7.1 channel system

- 7.1 channel playback is possible in ZONE2 if "7.1CH" is selected for the ZONE2 channel setting at "Channel Setup" in the System Setup Menu.

----- ZONE2 VIDEO signal cable

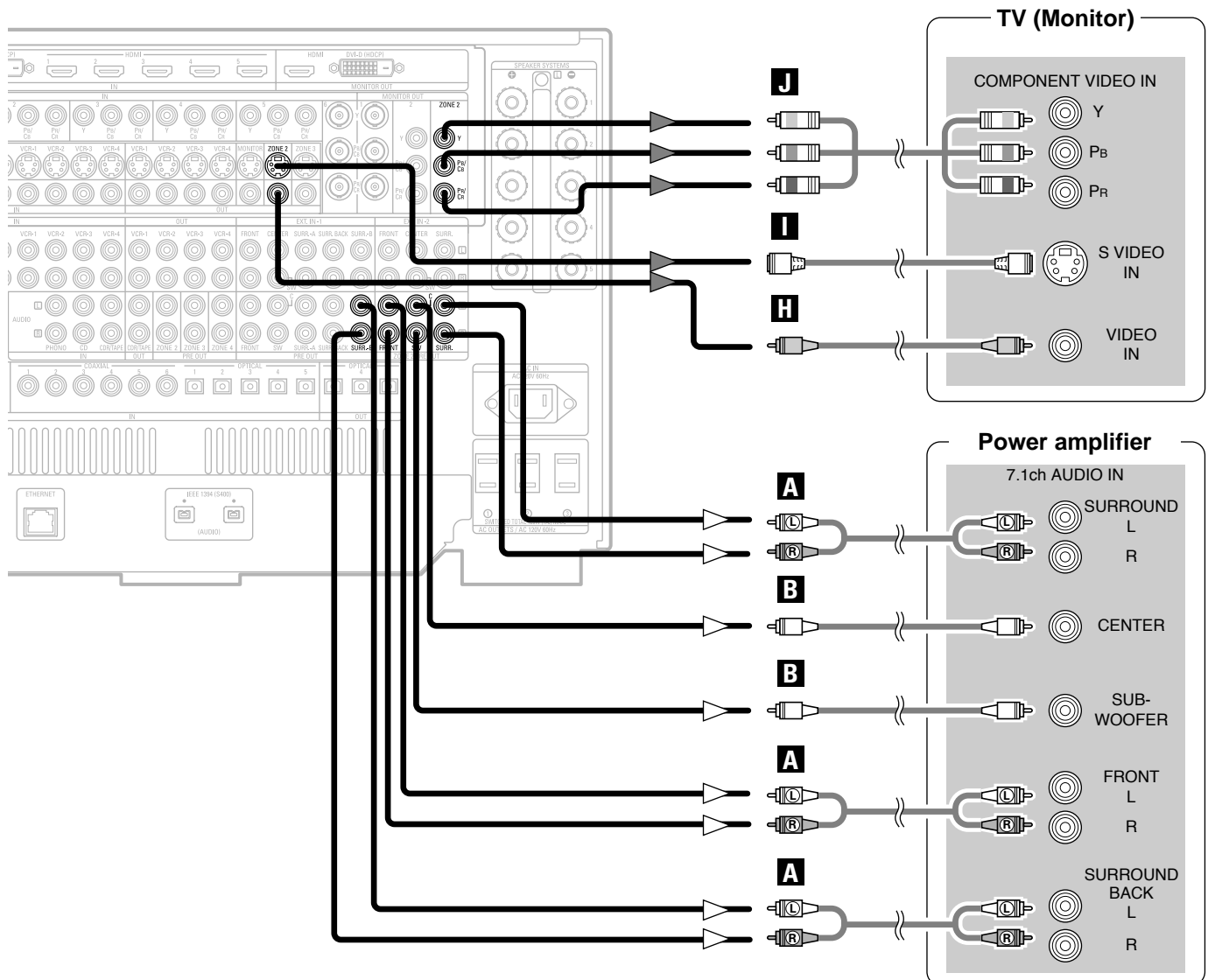
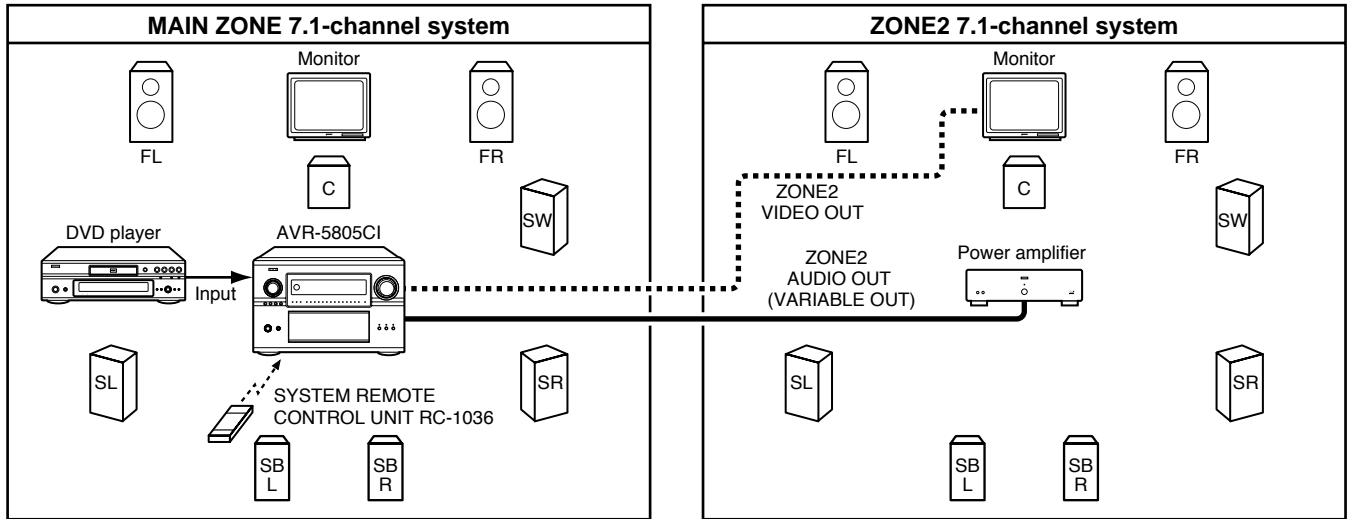

----- MULTI SOURCE AUDIO signal cable



Advanced Operation

■ ZONE2 STEREO/MONO system

- When two speakers are being used in ZONE2, select “STEREO” for the ZONE2 channel setting at “Channel Setup” in the System Setup Menu. Stereo sound can be enjoyed in ZONE2.
- When only one speaker is being used in ZONE2, select “MONO” for the ZONE2 channel setting at “Channel Setup” in the System Setup Menu. In this case, monaural sound can be enjoyed in ZONE2.

 ZONE2 VIDEO signal cable
 MULTI SOURCE AUDIO signal cable

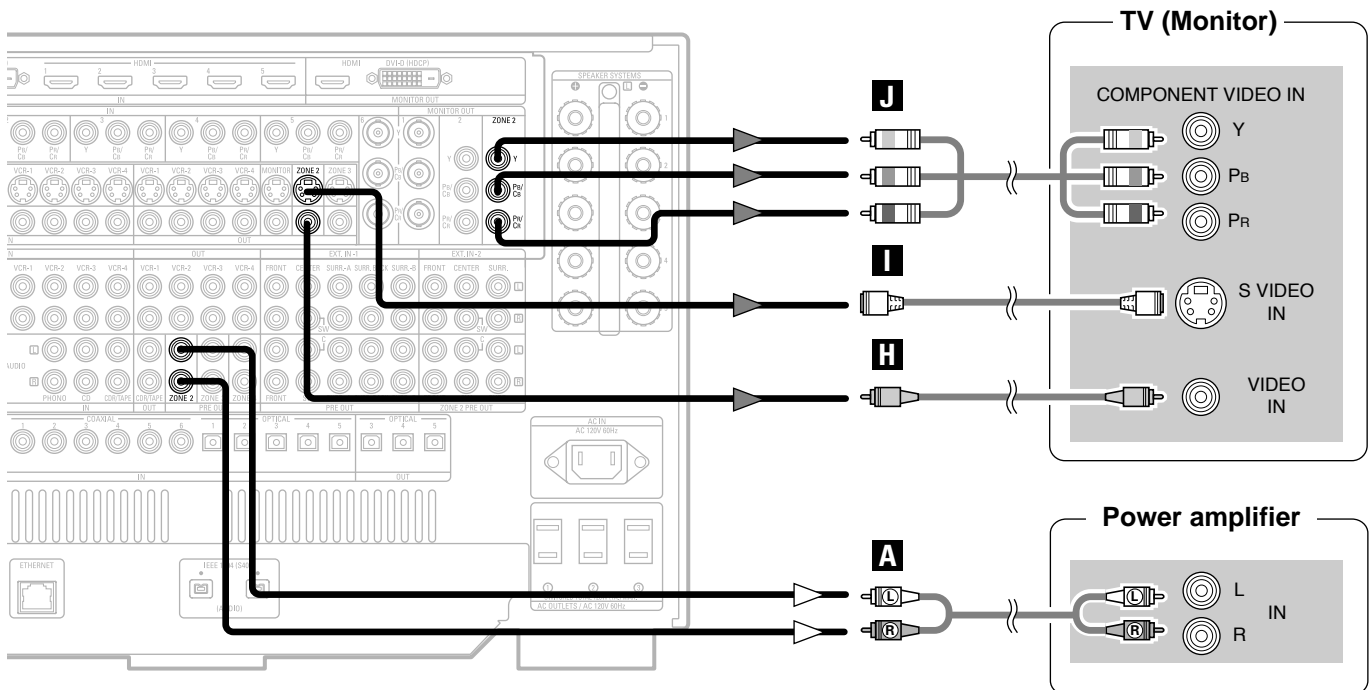
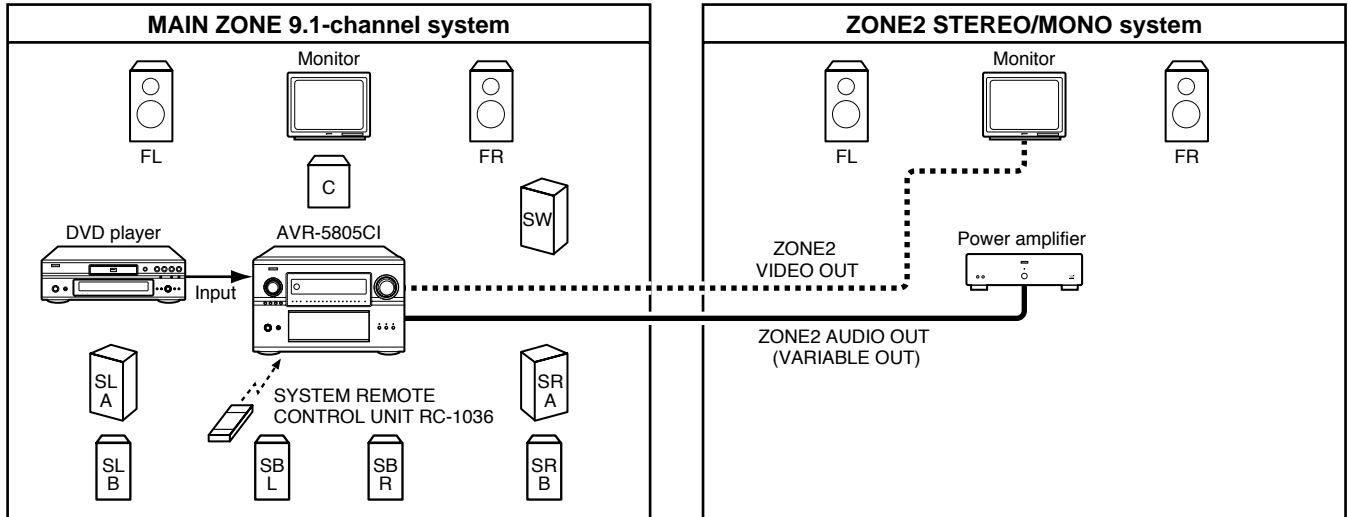

ZONE3 playback

- The AVR-5805CI is equipped with pre-out terminals for which the volume is adjustable and video output terminals (composite and S-Video) as the ZONE3 output terminals.
- When using a monitor in ZONE3, the input device's cable type must be the same as the type of cable connected to the AVR-5805CI's ZONE3 monitor output terminal (video or S-Video).

■ **ZONE3 STEREO/MONO system**

- Stereo and monaural sound can be enjoyed in ZONE3. (By default, "STEREO" is selected.)
- When only one speaker is being used in ZONE3, select "MONO" for the ZONE3 channel setting at "Channel Setup" in the System Setup Menu.

----- ZONE3 VIDEO signal cable
 ----- MULTI SOURCE AUDIO signal cable

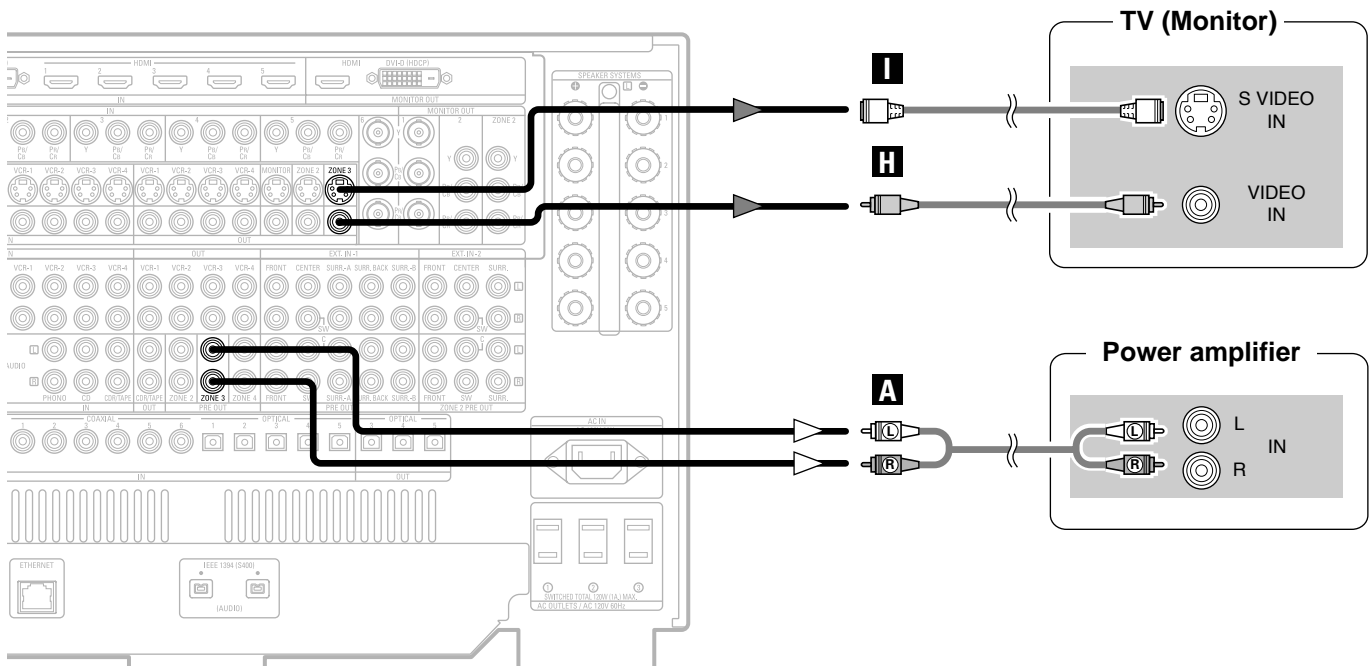
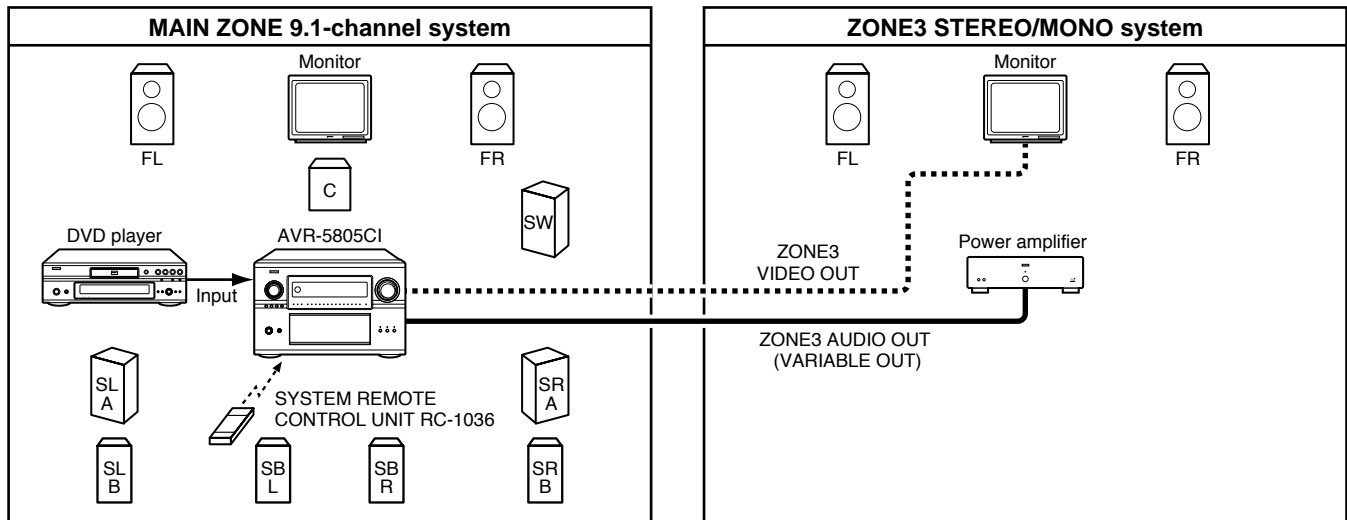

Advanced Operation

ZONE4 playback

- The AVR-5805CI is equipped with pre-out terminals for which the volume is adjustable as the ZONE4 output terminals.

■ ZONE4 STEREO/MONO system

- Stereo and monaural sound can be enjoyed in ZONE4. (By default, "STEREO" is selected.)
- When only one speaker is being used in ZONE4, select "MONO" for the ZONE4 channel setting at "Channel Setup" in the System Setup Menu.

MULTI SOURCE AUDIO signal cable

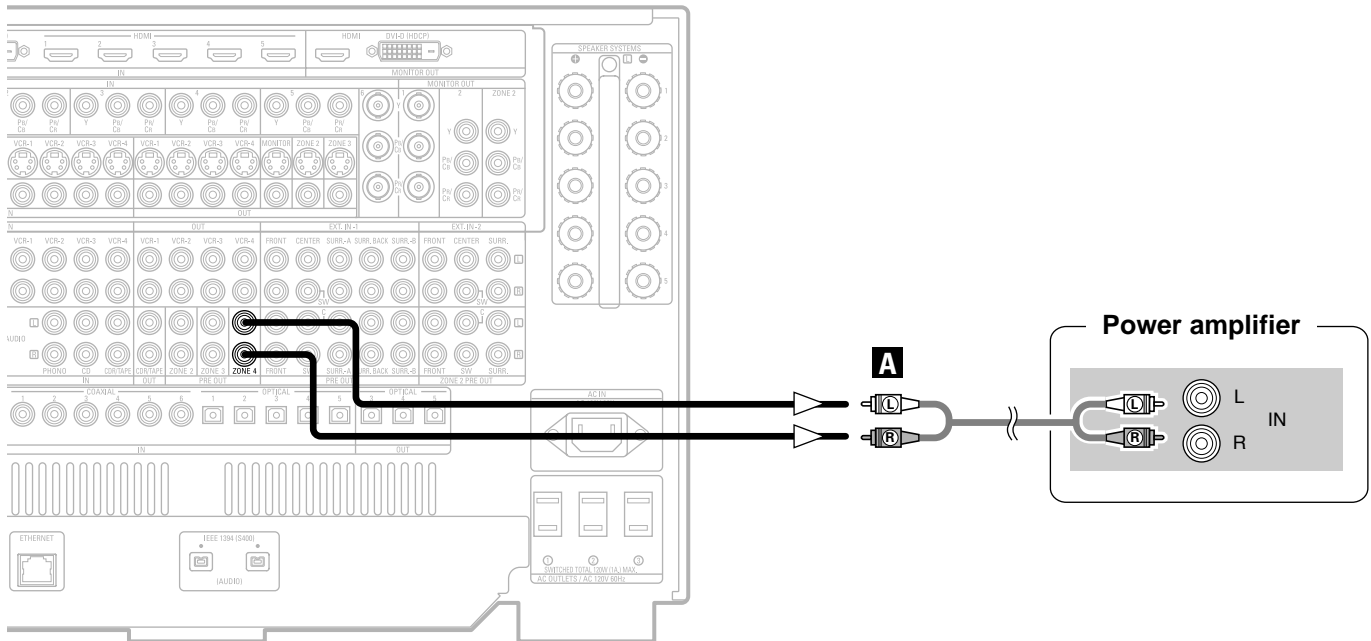
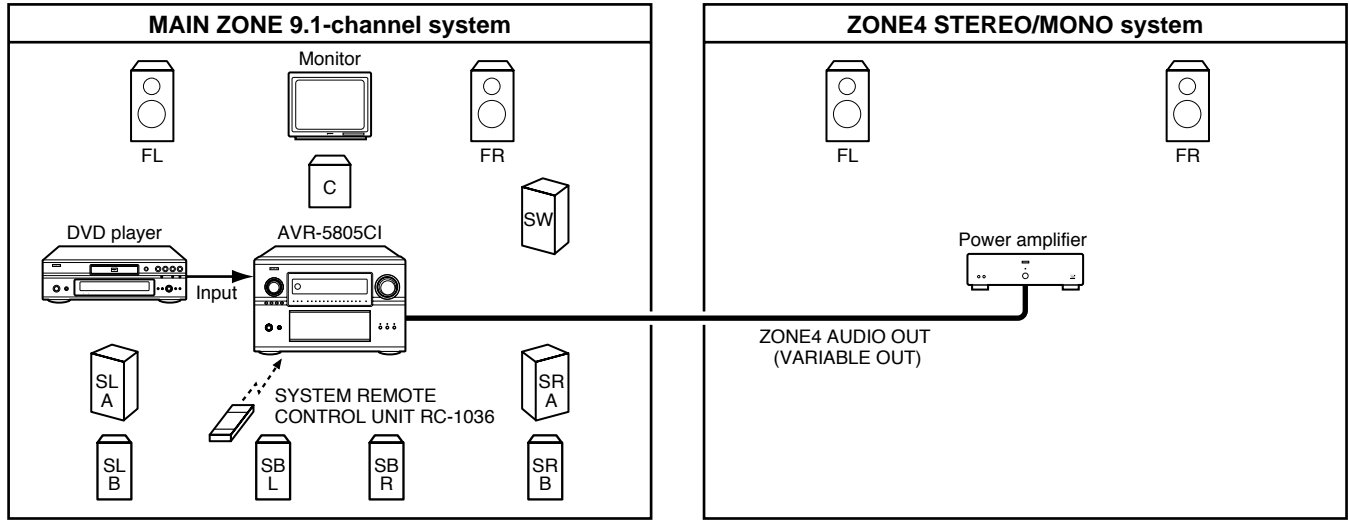

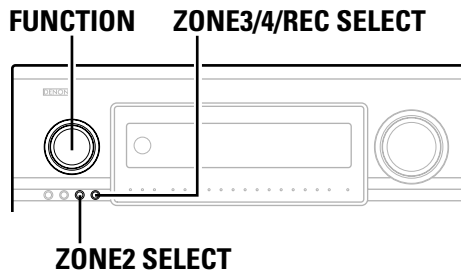

Outputting a program source to an amplifier, etc., in a ZONE2 room (ZONE2 SELECT mode)

- 1** Press the **ZONE2 SELECT** button to display the “ZONE2 SOURCE” on the display.
- 2** Turn the **FUNCTION** knob to select the source you want to output appears on the display.
- 3** Start playing the source to be output.
 - ※ For operating instructions, refer to the manuals of the respective components.

Outputting a program source to an amplifier, etc., in a ZONE3 or ZONE4 room (ZONE3, ZONE4 SELECT mode)

- 1** Press the **ZONE3/4/REC SELECT** button to display the “ZONE3 (ZONE4) SOURCE” on the display.
 - If the “ZONE3 SOURCE” is selected, the MULTI indicator light.
 - ※ The display switches as follows each time the button is pressed.

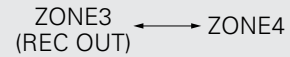

- 2** Turn the **FUNCTION** knob to select the source you want to output appears on the display.
- 3** Start playing the source to be output.
 - ※ For operating instructions, refer to the manuals of the respective components.



- The signals of the source selected in the ZONE3 mode are also output from the VCR-1, VCR-2, VCR-3, VCR-4 and CDR/TAPE recording output terminals.
- Digital signals are not output from the ZONE3 and ZONE4 audio output terminals.
- About the MULTI ZONE connections (👉 page 88 ~ 92).

Advanced Operation

Multi zone power indicators

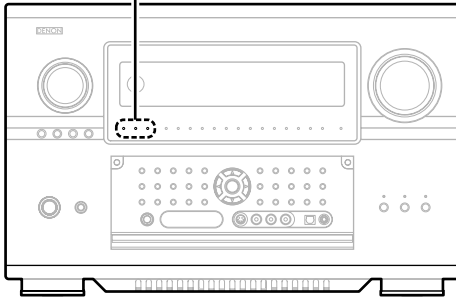

Remote control unit operations during multi-source playback

- 1** Select the zone which you want to operate pressing the **AMP** buttons.
- 2** Press the **ON** button to turn on the Zone power.
 - The multi zone power indicator light.
 - ※ Press the **OFF** button to turn off the zone power. The multi zone power indicator on main unit is off.
- 3** Press the **FUNCTION** button to select the input function you wish to operate.
- 4** Select the input mode. (only ZONE2 mode): Press the **INPUT MODE** button to switch to the input.

AUTO ← → ANALOG

- 5** The volume of the outputs of the different zones can be adjusted with the **VOLUME** button on the remote control unit.
 - ※ The output level can be controlled only if the zone volume level is set "variable" at "Volume Control" in the "System Setup Menu" (👉 page 134).
 - ※ Default volume setting
 ZONE2 : -40 dB
 ZONE3 : -40 dB
 ZONE4 : -40 dB
 - ※ The Zone volume can be adjusted within the range of -80 to 18 dB, in steps of 1 dB. However, when using with ZONE2 set to multi-channel (5.1 or 7.1 channel), the ZONE2 volume can be adjusted in steps of 0.5 dB (👉 page 126 ~ 128).



- The **MUTE** button can be operated in the same way as for the MAIN ZONE (👉 page 45).
- In the ZONE2 mode, the **VIDEO SELECT** and **ON SCREEN** buttons can be operated in the same way as for the MAIN ZONE (👉 page 45, 46).

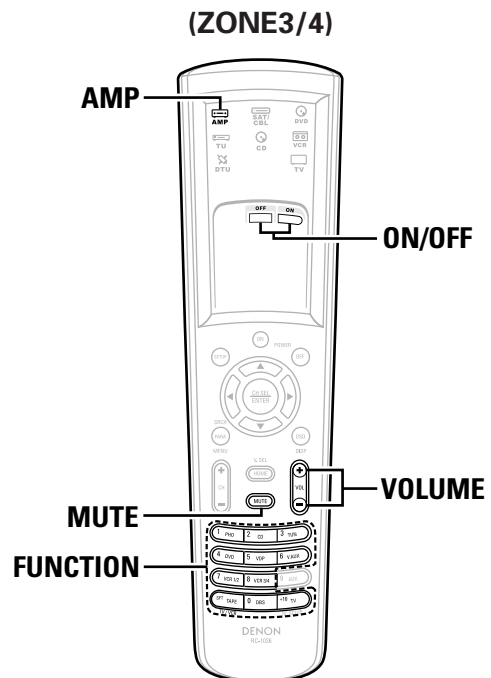
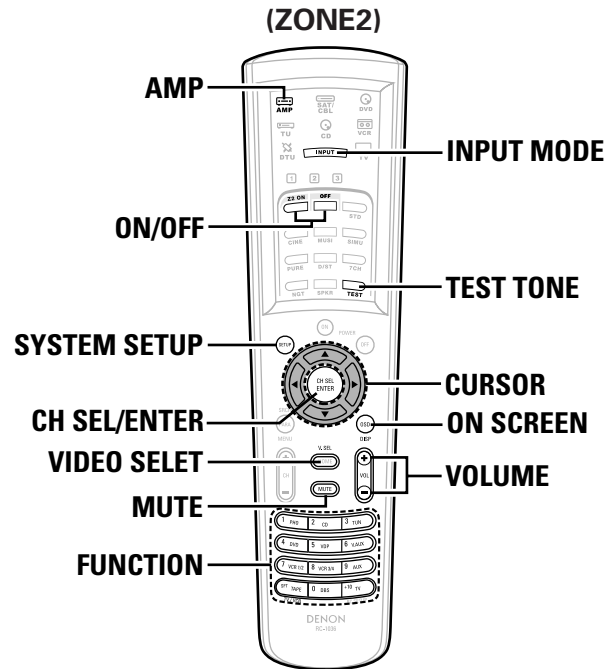

System setup for multi-zone

- This makes possible to make the optimum setting for the speaker systems used in ZONE2.

1 Select the **ZONE2** mode using the **AMP** button.

2 Press the **SYSTEM SETUP** button.

- The ZONE2 system setup menu appears.

※ The screen displayed depends on the settings made at "Channel Setup" (page 126 ~ 128).

Example: When "ZONE2" is set for a 5.1 or 7.1 channel system

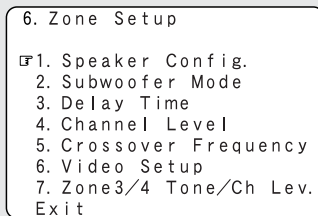

Example: When "ZONE2" is set for a STEREO or MONO

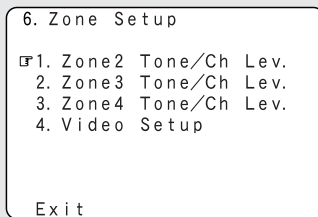

- For instructions on making the settings (page 120 ~ 125).

Adjustment steps that need to be performed prior to surround sound playback in ZONE2

■ Test Tone

- Before playing with the surround function, be sure to use the test tones to adjust the playback level from the different speakers. This adjustment can be performed with the system setup (page 122, 123) or from the remote control unit, as described below.
- Adjusting with the remote control unit using the test tones is only possible in the "Auto" mode and only effective in the STANDARD (DOLBY/DTS SURROUND) modes. The adjusted levels for the different modes are automatically stored in the memory.

1 Select the **ZONE2** mode using the **AMP** button.

2 Press the **TEST TONE** button.

- The "Test Tone" screen appears.

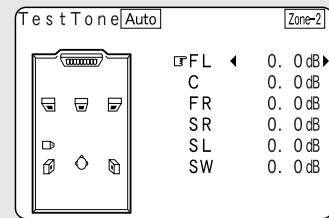

3 Press the **CURSOR** ◀ or ▶ button to adjust all the speakers to the same volume.

4 After completing the adjustment, press the **TEST TONE** button again.

■ Channel Level

- After adjusting using the test tones, adjust the channel levels either according to the playback sources or to suit your tastes, as described below.

1 Select the **ZONE2** mode using the **AMP** button.

2 Press the **CH SEL/ENTER** button.

- The "Channel Vol." screen appears.

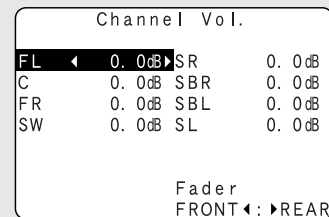

3 Press the **CURSOR** △, ▽ or **CH SEL/ENTER** button to select the speaker.

- ※ The channel switches as shown below each time the **CH SEL/ENTER** button is pressed.

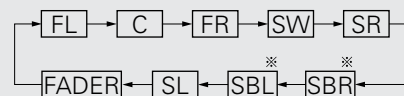

- ※ ZONE2 surround back speakers are only displayed when "7.1ch" is selected for the ZONE2 channel output setting at "Channel Setup" (page 126 ~ 128).
- ※ When the ZONE2 surround back speaker setting is set to "1spkr" for "Speaker Configuration", this is set to "SB".

4 Press the **CURSOR** ◀ or ▶ button to adjust the level.

- ※ The adjustment range for the different channels is +12.0 dB to -12.0 dB.
- ※ The sound from the subwoofer can be completely cut by lowering the SW (subwoofer) setting one additional step from -12.0 dB (setting it to "OFF").

Advanced Operation

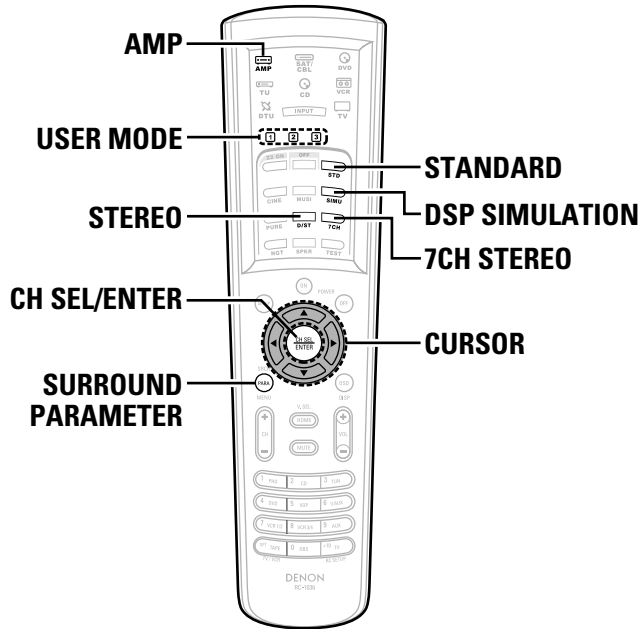

- ※ ZONE2 surround back speakers are only displayed when “7.1ch” is selected for the ZONE2 channel output setting at “Channel Setup”.
- ※ When the ZONE2 surround back speaker setting is set to “1spkr” for “Speaker Configuration”, this is set to “SB”.

4 Press the **CURSOR** ◀ button to reduce the volume of the front channels, the **CURSOR** ▶ button to reduce the volume of the rear channels.

- ※ The fader function does not affect the SW channel.



- The channel whose channel level is adjusted lowest can be faded to -12.0 dB using the fader function.
- If the channel levels are adjusted separately after adjusting the fader, the fader adjustment values are cleared, so adjust the fader again.

■ Fader function

- This function makes it possible to lower the volume of the front channels (FL, C and FR) or the rear channels (SL, SR, SBL and SBR) of ZONE2 together. Use it for example to adjust the balance of the sound from each position when multi-channel music sources are played.

1 Select the **ZONE2** mode using the **AMP** button.

2 Press the **CH SEL/ENTER** button.

- The “Channel Vol.” screen appears.

Channel Vol.			
FL	◀ 0.0dB ▶	SR	0.0dB
C	0.0dB	SBR	0.0dB
FR	0.0dB	SBL	0.0dB
SW	0.0dB	SL	0.0dB
Fader			
FRONT ◀ : ▶ REAR			

3 Press the **CURSOR** ▲, ▼ or **CH SEL/ENTER** button then select “Fader”.

- ※ The channel switches in the order shown below each time the **CH SEL/ENTER** button is pressed.

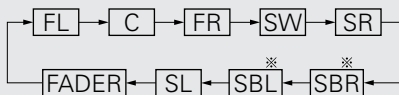

Channel Vol.			
FL	0.0dB	SR	0.0dB
C	0.0dB	SBR	0.0dB
FR	0.0dB	SBL	0.0dB
SW	0.0dB	SL	0.0dB
Fader			
FRONT ◀ : ▶ REAR			

ZONE2 Surround

- When ZONE2 is used with a 5.1 or 7.1 channel system, various surround modes can be selected according to the program source being played.
- The desired sound field can be achieved by adjusting the parameters for the various surround modes.

1 Select the ZONE2 mode using the AMP button.

2 Select the surround mode for each input channel.

- ① STANDARD (Dolby Digital/DTS Surround) mode. ② DSP surround simulation mode.



(Remote control unit)



(Remote control unit)

- ※ The surround mode switches in the following order each time the **DSP SIMULATION** button is pressed.

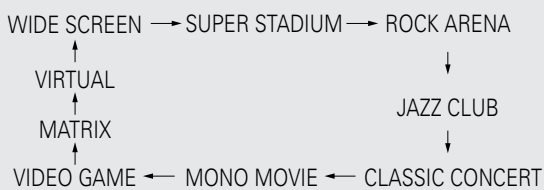

- ③ STEREO mode. ④ 5CH/7CH STEREO mode.



(Remote control unit)

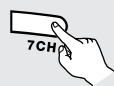

(Remote control unit)

- ※ See pages 49, 54 ~ 58, 61 for a description of the features of the various surround modes.
- ※ The following surround modes can be selected in ZONE2: STEREO, STANDARD (DOLBY/DTS SURROUND), 5/7CH STEREO, WIDE SCREEN, SUPER STADIUM, ROCK ARENA, JAZZ CLUB, CLASSIC CONCERT, MONO MOVIE, VIDEO GAME, MATRIX and VIRTUAL.

3 Press the SURROUND PARAMETER button.

- The surround parameter menu appears.

4 Press the CURSOR Δ or ∇ button to select the various surround parameters.

5 Press the CURSOR \triangleleft or \triangleright button to adjust the parameters setting.

6 Press the ENTER or SURROUND PARAMETER button to complete the setting.

USER MODE function of ZONE2

- The AVR-5805CI is equipped with a function for storing the input source, auto surround mode and input mode settings selected for the MAIN ZONE and ZONE2 in the memory so they can be used whenever desired.
- For ZONE2, three patterns of settings can be stored in the memory using the **USER MODE 1, 2** and **3** buttons on the Remote control unit.
- See page 60 for a description of the MAIN ZONE's "USER MODE" function.

■ Storing the settings in the memory

- ### 1 Set the following to the desired status:
- ① ZONE2 input source
 - ② ZONE2 auto surround mode
 - ③ ZONE2 input mode

2 Select the ZONE2 mode using the AMP button.

3 Press and hold the USER MODE button until the "USER 1 (2 or 3) MEMORY" is appears on the ZONE2 monitor.

■ Calling the settings out

1 Select the ZONE2 mode using the AMP button.

2 Press the USER MODE button at which the settings you want to call out are stored.

Advanced Operation

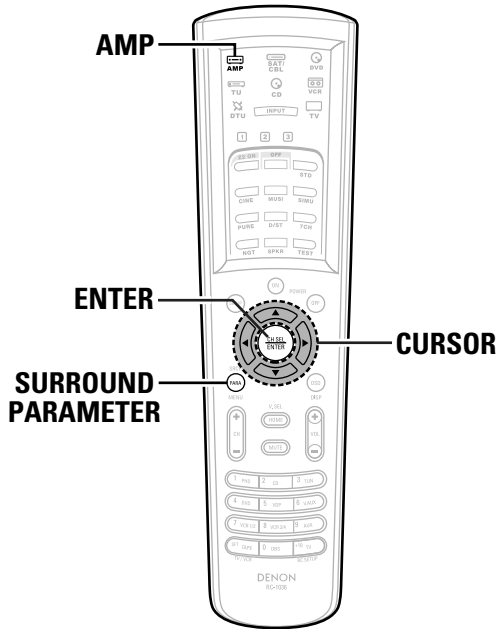

ZONE2 tone control setting

- This function allows you to adjust the bass and treble of the ZONE2 audio output during surround playback in ZONE2 to suit your tastes.

1 Select the **ZONE2** mode using the **AMP** button.

2 Press the **SURROUND PARAMETER** button.

- The surround parameter menu appears.

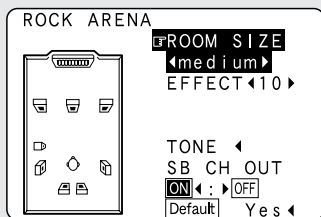

※ The screen selected surround mode appears.

3 Press the **CURSOR** Δ or ∇ button to select **"TONE"**.

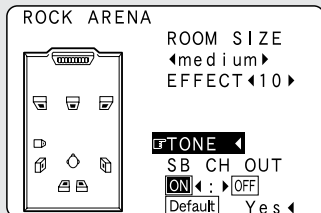

4 Press the **CURSOR** \triangleleft button.

- Switch to the "Tone Control" screen.

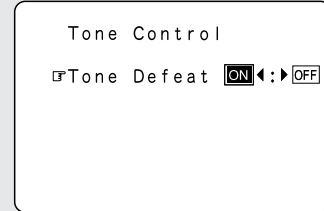

5 Press the **CURSOR** \triangleright button to select **"Tone Defeat OFF"**.



※ If you do not want to the tone to be adjusted, set "Tone Defeat" to "ON".

6 Press the **CURSOR** Δ or ∇ button to select **"Bass"** or **"Treble"**.

7 Press the **CURSOR** \triangleleft or \triangleright button to set the level.

8 Press the **ENTER** button.

- The surround parameter menu reappears.

9 Press the **ENTER** or **SURROUND PARAMETER** button to complete the setting.

Other function

FUNCTION

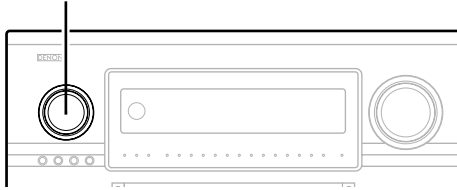

DIRECT/STEREO

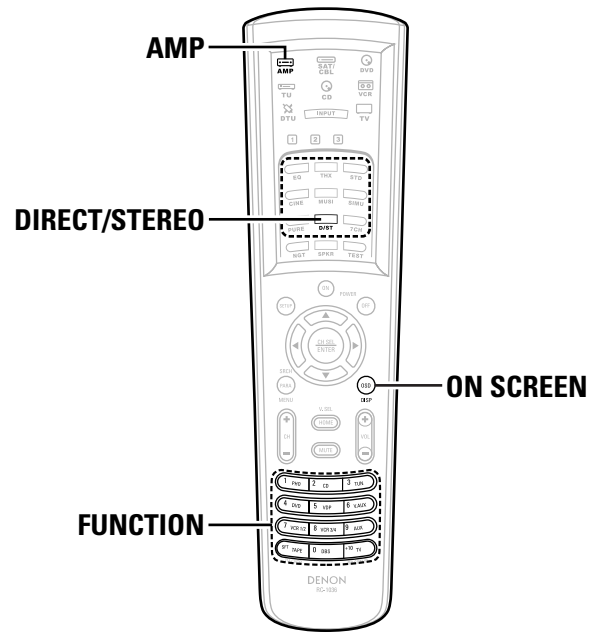
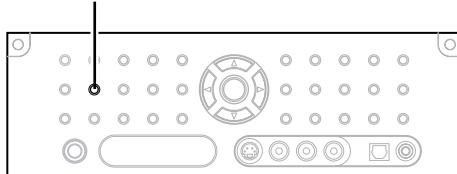

Playing Super Audio CDs with an IEEE1394 cable

1 Select the input source to which IEEE1394 was assigned at the “IEEE1394 Assign” (page 107) in the system setup.

Example: CD

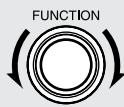

(Main unit)



(Remote control unit)

- The IEEE1394 indicator lights.

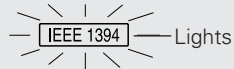

2 Select the surround mode.

Example: DIRECT



(Main unit)



(Remote control unit)

3 Start playback on the selected component.

- The DSD indicator lights.

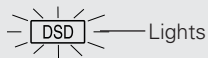

- ※ For operating instructions, refer to the component's manual.
- ※ “DSD DIRECT” is shown on the display when playing DSD 2 channel signals in the DIRECT mode. “DSD MULTI DIRECT” is displayed when playing DSD multi-channel signals in the DIRECT mode (SB CH OUT “OFF”).

When playing DSD signals in the DIRECT or PURE DIRECT mode, the DSD signals are converted into analog signals. When playing in other surround modes, the DSD signals are first converted into PCM signals. The input signal and playing status can be checked by pressing the **ON SCREEN** button on the remote control unit.

Example: When DSD multi-channel signals are played in the DIRECT mode

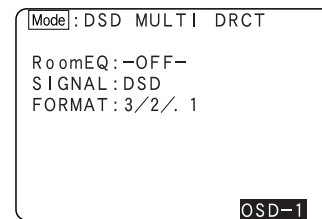

Example: When DSD multi-channel signals are played in the 9CH STEREO mode

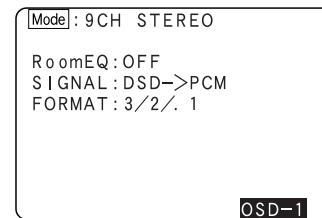

Advanced Operation

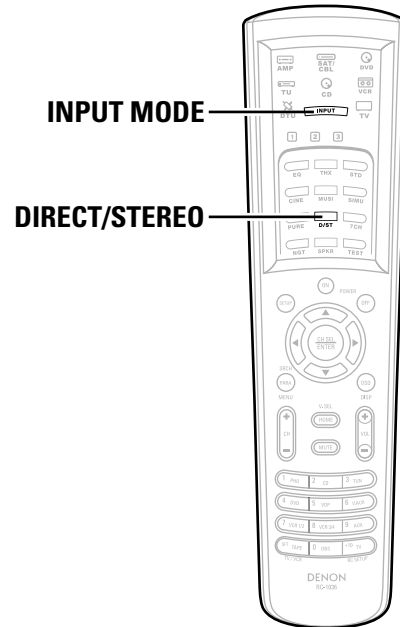
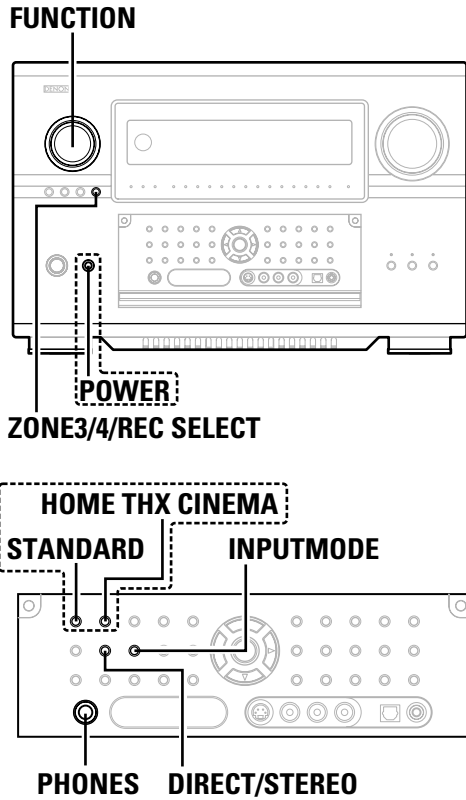

Multi-source recording / playback

■ Playing one source while recording another (REC OUT mode)

1 Press the **ZONE3/4/REC SELECT** button until “ZONE3 SOURCE” appears on the display.

2 With “ZONE3 SOURCE” displayed, turn the **FUNCTION** knob until “RECOUT SOURCE” appears on the display.

- The REC indicator lights.

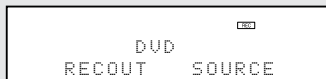

- ※ The function switches as shown below when the **FUNCTION** knob is turned.

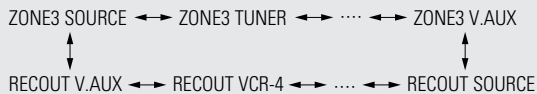

3 With “RECOUT SOURCE” displayed, turn the **FUNCTION** knob to select the source you wish to record.

4 Set the recording mode.

- Start recording.

- ※ For operating instructions, refer to the manual of the component on which you want to record.



- To cancel, turn the **FUNCTION** knob and select “SOURCE”.
- Recording sources other than digital inputs selected in the REC OUT mode are also output from the ZONE3 audio/video terminals.
- When the REC OUT mode is selected, the **ZONE3** button on the remote control unit cannot be operated.

■ Recording Dolby Digital and DTS multi channel sources

- With this set it is possible to record Dolby Digital and DTS multichannel signals converted into 2 channel analog signals.
- The recording signals are output to the TAPE and VCR output terminals.
- Down-mixed analog signals converted into digital signals are output from the OPTICAL 3, 4 and 5 digital output terminals at this time.

1 Press the **ZONE3/4/REC SELECT** button until “RECOUT SOURCE” appears on the display.

2 Press the **INPUT MODE** button to set the input mode according to the source to be played.

3 Press the **DIRECT/STEREO** button to set the surround mode.

- The multichannel digital signals are down-mixed and output to the TAPE and VCR output terminals.

4 Set the recording mode.

NOTE:

- This function does not work when “5.2 ch / 5.3 ch” is set for the MAIN ZONE’s channel setup.

■ Dolby Headphone recording

- When REC OUT mode is set to "SOURCE", with the AVR-5805CI it is possible to output signals encoded in the Dolby Headphone mode from the recording output terminal and record them on a separate recorder.

1 The Dolby Headphone play mode is set when headphones are connected to the PHONES jack during playback in the STANDARD (DOLBY/DTS Surround) mode.

- When this is done, signals encoded in the Dolby Headphone mode are automatically output from the recording output terminals (analog and digital) and can be recorded.

2 Select the parameters and set the desired mode.

- Start recording.

※ Refer to the "Dolby Headphone" (👉 page 59).

NOTE:

- Do not disconnect the headphones during recording.

Last Function Memory

- This unit is equipped with a last function memory which stores the input and output setting conditions as they were immediately before the power is switched off. This function eliminates the need to perform complicated resetting when the power is switched on.
- The unit is also equipped with a back-up memory. This function provides approximately one week of memory storage from when the main unit's power switch is off and with the power supply cord disconnected.

Initialization of the Microprocessor

- In very rare instances, the AVR-5805CI internal microprocessor might lock up, or otherwise cause mis-operation. This might be caused due to an AC line surge or line spike noise, or by static electric discharge on or nearby the unit, or to connected components. If the condition cannot be corrected by powering off the unit, including disconnection of the power supply cord for a period of ten minutes and subsequent re-connection, then the unit may have to be re-initialized. Doing so will restore the microprocessor to its original out-of-the-box state, with all custom memories and settings erased, and the original factory default settings restored. Only use this procedure if you are sure that the microprocessor requires re-initialization.

1 Switch off the unit using the main unit's POWER switch.

2 Hold the following STANDARD button and HOME THX CINEMA button, and turn the main unit's POWER switch on.

3 Check that the entire display is flashing with an interval of about 1 second, and release your fingers from the 2 buttons.

- The microprocessor will be initialized.



- If step 3 does not work, start over from step 1.
- If the microprocessor has been reset, all the settings are reset to the default values (the values set upon shipment from the factory).

Advanced Setup – Part 1

- You can customize a variety of system setup so that it may be fitting for your listening environment. For the contents of a system menu and the initial setting of this unit (see page 153 ~ 156).

Navigating through the System Setup Menu

- You can change setting using the buttons on the front panel or remote control unit.

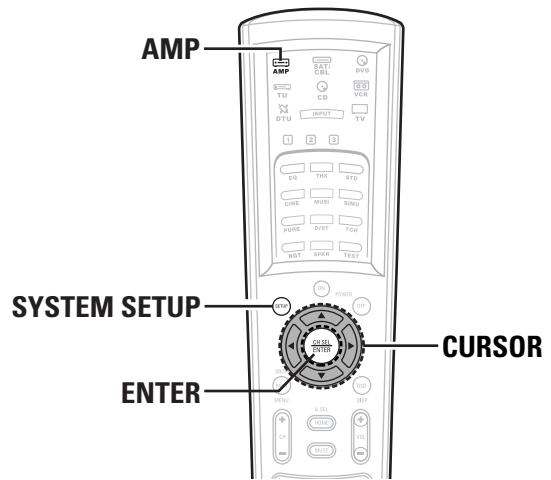
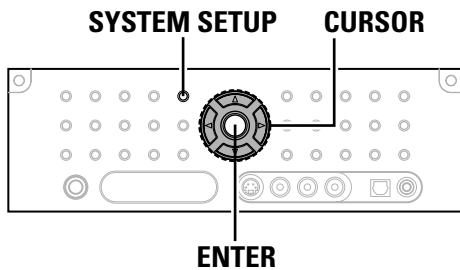

- 1** Press the **AMP** button to select the “AMP” mode.
- 2** Press the **SYSTEM SETUP** button.
 - The “System Setup Menu” appears.
- 3** Press the **CURSOR** Δ or ∇ button to select the item you want to set, then press **ENTER** button.
- 4** Press the **CURSOR** Δ or ∇ again to select the item you want to set, then press **ENTER** button.
- 5** To change the setting: Press **CURSOR** Δ or ∇ button to select the item you want to change, then press **CURSOR** \triangleleft or \triangleright button to change the setting.
 - ※ Select “Default Yes”, then press the **CURSOR** \triangleleft button to reset to the default setting.
- 6** Press the **ENTER** button and set a new item.
- 7** Press the **SYSTEM SETUP** button to return to the “System Setup Menu” or the main menu.

[On screen display]	[Display]
3 <div style="border: 1px solid black; padding: 5px; margin-bottom: 10px;"> System Setup Menu 1. Auto Setup/Room EQ 2. Speaker Setup 3. Audio Input Setup 4. Video Setup 5. Advanced Playback 6. Zone Setup 7. Option Setup Exit </div> 4 <div style="border: 1px solid black; padding: 5px; margin-bottom: 10px;"> 3. Audio Input Setup 1. Digital In Assign 2. EXT. IN Setup 3. Input Function Lev. 4. Function Rename 5. IEEE1394 Assign 6. IEEE1394 Auto Func. 7. Tuner Presets Exit </div> 5 <div style="border: 1px solid black; padding: 5px; margin-bottom: 10px;"> 3-1. Digital In Assign CD : \triangleleftCOAX1\triangleright Tape : OPT5 DVD : COAX2 V.Aux : OPT6 VDP : COAX3 TV : COAX4 DBS : COAX5 VCR-1 : OPT1 VCR-2 : OPT2 VCR-3 : OPT3 VCR-4 : OPT4 Default Yes\triangleleft </div> 7 <div style="border: 1px solid black; padding: 5px;"> System Setup Menu 1. Auto Setup/Room EQ 2. Speaker Setup 3. Audio Input Setup 4. Video Setup 5. Advanced Playback 6. Zone Setup 7. Option Setup Exit </div>	<div style="border: 1px solid black; padding: 5px; margin-bottom: 10px; text-align: center;"> *System Setup Audio In Setup </div> <div style="border: 1px solid black; padding: 5px; margin-bottom: 10px; text-align: center;"> *Audio In Setup Digital In </div> <div style="border: 1px solid black; padding: 5px; margin-bottom: 10px; text-align: center;"> *Digital In CD : \triangleleftCOAX1\triangleright </div> <div style="border: 1px solid black; padding: 5px; text-align: center;"> *System Setup Exit </div>



On screen display and front display

- The AVR-5805CI is equipped with an intuitive and easy-to-understand on screen display, and is equipped with an alpha-numeric front panel display tube that can also be used to check and adjust settings. We recommend that you use the on screen display when you make system adjustments. Some representative front panel and on screen display examples are shown below.

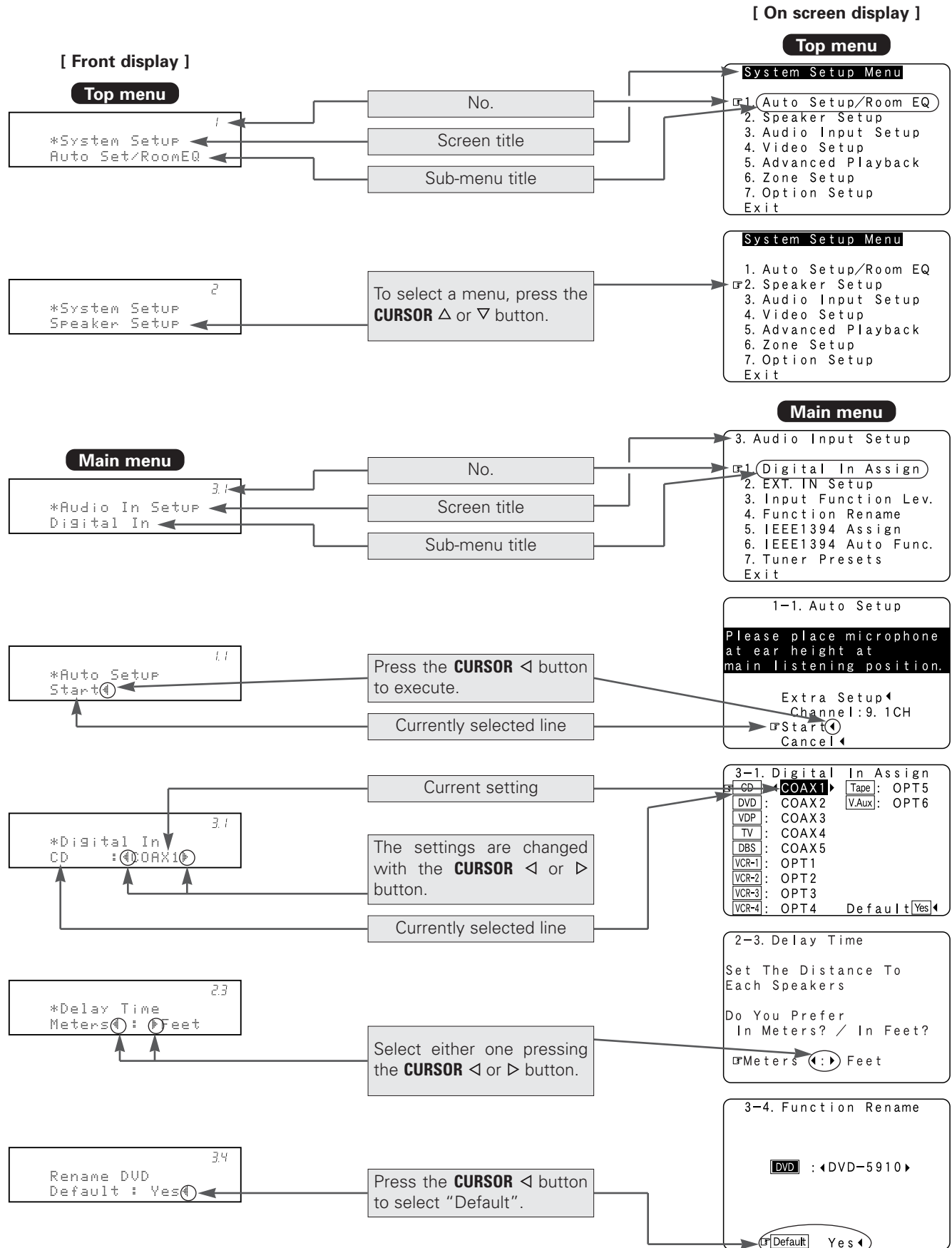

Audio Input Setup

- Make the audio-related settings.

Setting the Digital In Assignment

- This assigns the digital input terminals for the different input sources.

1 Press the **CURSOR** Δ or ∇ button to select “Audio Input Setup” at the “System Setup Menu”, then press the **ENTER** button.

- The “Audio Input Setup” menu appears.

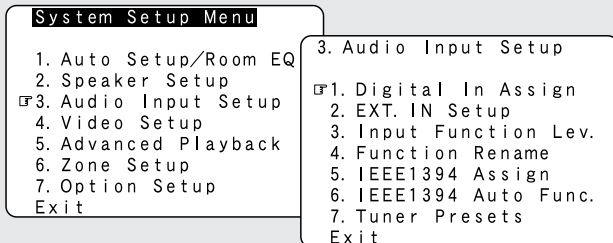

2 Press the **CURSOR** Δ or ∇ button to select “Digital In Assign”, then press the **ENTER** button.

- The “Digital In Assign” screen appears.

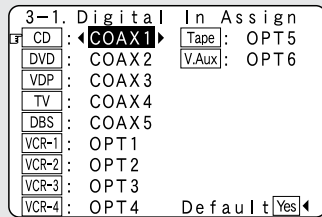

3 Press the **CURSOR** Δ or ∇ button to select the input source, then press the **CURSOR** \triangleleft or \triangleright button to select the digital input terminal.

- ※ Select from among COAX 1 to 6, OPT 1 to 5.
- ※ If the same digital input terminal is selected, the setting for the input source that was previously assigned switches to “OFF”.
- ※ The HDMI input terminal is displayed when it is assigned to the input source at “HDMI/DVI In Assign” (page 111, 112).
- ※ If an input source is assigned to a device connected with an IEEE1394 cable at “IEEE1394 Assign”, the digital input terminal’s assignment setting switches to “OFF”.
- ※ When “Default Yes” is selected, then press the **CURSOR** \triangleleft button to reset to the default values.

4 Press the **ENTER** button to enter the setting.

- The “Audio Input Setup” menu reappears.



- The OPTICAL 3, 4 and 5 terminals on the AVR-5805CI’s rear panel are equipped with an optical digital output terminal for recording digital audio signals to a CD recorder, MD recorder, or other digital audio recording deck. Use this for digital recording between a digital audio source (stereo – 2 channel) and a digital audio recorder.
- “PHONO” and “TUNER” cannot be selected on the “Digital In Assign” screen.
- Do not connect the output of the component connected to the OPTICAL 3 (to 5) OUT terminal on the AVR-5805CI’s rear panel to any terminal other than the OPTICAL 3 (to 5) IN terminal.

Setting the DENON LINK

- When a DENON DVD player and the DENON LINK have been connected, be sure to make a setting to “DENON LINK” with the System Setup Digital In Assignment.
- When the input mode is AUTO and the signals are not able to transferred by DENON LINK, the unit automatically changes over the input to the selected signals (ANALOG, EXT. IN or IEEE1394).
- Refer to “DENON LINK connections” (page 35).

1 Press the **CURSOR** Δ or ∇ button to select the input source, then press the **CURSOR** \triangleleft or \triangleright button to select “DLINK”.

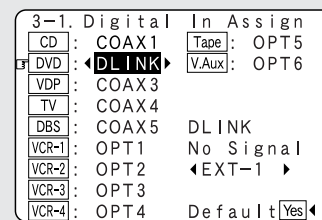

2 Press the **CURSOR** Δ or ∇ button to select “DLINK” setting, then press the **CURSOR** \triangleleft or \triangleright button to select the input signal (ANALOG, EXT. IN or IEEE1394).

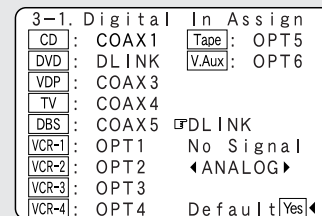

- ※ If the signal cannot be played with DENON LINK connection, the signal automatically switches to the input from the set terminal.

Setting the EXT. IN Setup

- Set the EXT. IN terminals playback method.

1 Press the **CURSOR** Δ or ∇ button to select “EXT. IN Setup” at the “Audio Input Setup” menu, then press the **ENTER** button.

- The “EXT. IN Setup” screen appears.

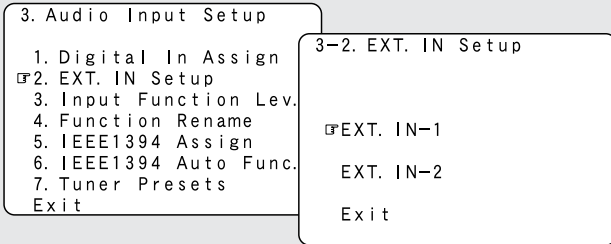

2 Press the **CURSOR** Δ or ∇ button to select the input terminal, then press the **ENTER** button.

- Switch to the setting screen.

3 Press the **CURSOR** Δ or ∇ button to select the item to be set, then press the **CURSOR** \triangleleft or \triangleright button to select the parameter.

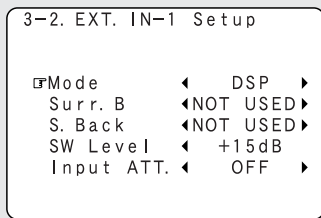

Mode:

- **DSP:**

The analog input signal is converted into a digital signal and undergoes DSP processing. System Setup settings (Speaker Configuration, Delay Time, etc.) are reflected in the same way as for other input signals. The surround playback mode button functions.

- **ANALOG:**

The analog input signal is played without DSP processing. SW and center channel: Down-mixing is conducted by the analog circuit. Surround and surround back channels: Not output if “No” is selected at the Speaker Configuration. Delay Time: Not reflected.

S. Back:

Set when “Mode” is set to “DSP”. Select according to the specifications of the player being used. Also refer to the player’s operating instructions.

- **NOT USED:**

Select when neither SBL or SBR is connected.

- **SB (SBL):**

Select when only one surround back channel (SBL) is connected.

- **SBL/SBR:**

Select when two surround back channels (SBL and SBR) are connected.

Surr. B:

Select according to the specifications of the player being used. Also refer to the player’s operating instructions.

- **NOT USED:**

Select when Surround B is not terminals.

The Surround A input signal is output to the Surround B output terminals.

- **USED:**

Select when Surround B is connected. The playback in the MULTI CH DIRECT and MULTI CH IN is only possible when “Mode” is set to “DSP”.

Surr. Sp :

Set when “Mode” is set to “ANALOG”. Select according to the specifications of the player being used. Also refer to the player’s operating instructions.

- **Surr. A**

Select when using surround speakers A.

- **Surr. B**

Select when using surround speakers B.

- **Surr. A+B**

Select when using both surround speakers A and B.

SW Level :

Select according to the specifications of the player being used. Also refer to the player’s operating instructions.

Set the level of playback of the analog input signal connected to the EXT. IN Subwoofer.

+15dB (default) recommended. (0, +5, +10 and +15 can be selected.)

INPUT ATT.:

Set when “Mode” is set to “DSP”.

If “OVER LOAD” appears on the display, select “-6 dB”.

4 Press the **ENTER** button to enter the setting.

- The “EXT. IN Setup” menu reappears.

5 Press the **CURSOR** Δ or ∇ button to select the “Exit”, then press the **ENTER** button.

- The “Audio Input Setup” menu reappears.



- The items to be set differ as described below according to the selected input terminal and the “Mode” selection.

	EXT. IN-1 (10 CH)	
Mode	DSP	ANALOG
Surr. B	NOT USED / USED	NOT USED / USED
S. Back	NOT USED, SBL/SBR, SB (SBL)	-
Surr. Sp	-	Surr. A / Surr. B / Surr. A+B
SW Level	0, +5, +10, +15 dB	0, +5, +10, +15 dB
Input ATT.	OFF, -6 dB	-

	EXT. IN-2 (6 CH)	
Mode	DSP	ANALOG
Surr. B	-	-
S. Back	-	-
Surr. Sp	-	Surr. A / Surr. B / Surr. A+B
SW Level	0, +5, +10, +15 dB	0, +5, +10, +15 dB
Input ATT.	OFF, -6 dB	-



Advanced Setup – Part 1

Setting the Input Function Level

- The playback level is corrected individually for the different input sources.

1 Press the **CURSOR** Δ or ∇ button to select “Input Function Lev.” at the “Audio Input Setup” menu, then press the **ENTER** button.

- The “Input Function Lev.” screen appears.

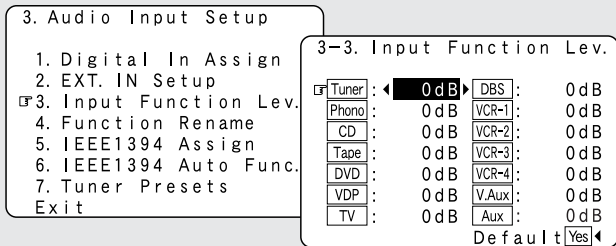

2 Press the **CURSOR** Δ or ∇ button to select the input source, then press the **CURSOR** \triangleleft or \triangleright button to adjust the level.

- ※ The level can be adjusted between -12 dB and $+12$ dB in units of 1 dB.
- ※ When “Default Yes” is selected, then press the **CURSOR** \triangleleft button to reset to the default values.

3 Press the **ENTER** button to enter the setting.

- The “Audio Input Setup” menu reappears.



- After completing this setting, check that the playback levels for the different sources are the same.

Setting the Function Rename

- The names of the different input function can be changed as desired and displayed on the display.

1 Press the **CURSOR** Δ or ∇ button to select “Function Rename” at the “Audio Input Setup” menu, then press the **ENTER** button.

- The “Function Rename” screen appears.

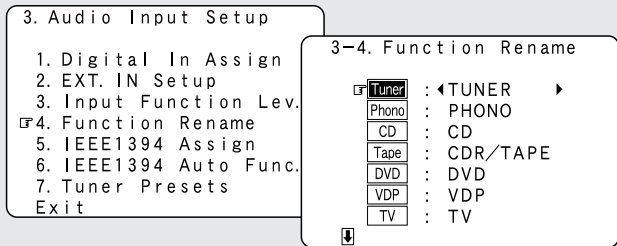

2 Press the **CURSOR** Δ or ∇ button to select the input function whose name you want to change, then press the **CURSOR** \triangleleft or \triangleright button.

- The screen switches to the character input screen.

Example: When “DVD” is selected and the **CURSOR** \triangleleft or \triangleright button is pressed

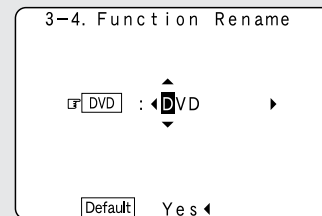

3 Press the **CURSOR** \triangleleft or \triangleright button to move the cursor (■) to the character, number, symbol or punctuation mark you wish to input, and press the **CURSOR** Δ or ∇ button to select that character.

ABCDEFGHIJKLMNOPQRSTUVWXYZ
 xyz0123456789
 ! " # % & ' () * + , - . / : ; < = > ? @ [\] (space)

- ※ Up to 8 characters can be input.

4 Repeat step 3 to input the input function name.

- ※ To reset the input function name to the default value, press the **CURSOR** ◀ or ▶ button to highlight the input function display, then press the **CURSOR** ▼ button. When “Default Yes” is selected, then press the **CURSOR** ◀ button to reset to the default input function name.

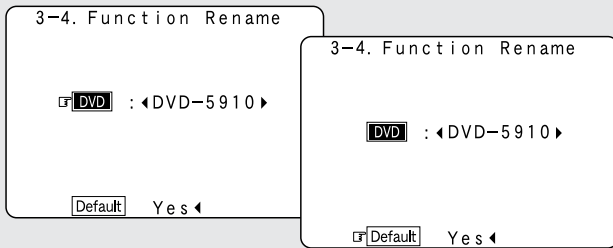

5 Once all the characters have been input, press the ENTER button.

- The “Function Rename” screen reappears.

- ※ Use the same procedure to change other input function names as well.

6 Press the ENTER button to enter the setting.

- The “Audio Input Setup” menu reappears.



- When the input function is selected, the display is as shown below.

Example: When the name has been changed to “DVD-5910”

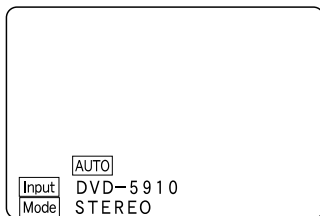

Setting the IEEE1394 Assignment

- Assign the device connected by IEEE1394 cable to an input source. The power of the device to be assigned must be turned on ahead of time.

1 Press the CURSOR ▲ or ▼ button to select “IEEE1394 Assign” at the “Audio Input Setup” menu, then press the ENTER button.

- The “IEEE1394 Assign” screen appears.

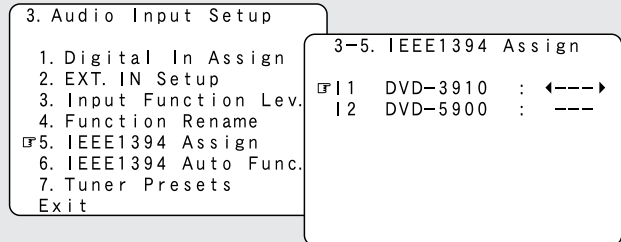

2 Press the CURSOR ▲ or ▼ button to select the device to be assigned to the input source, then press the CURSOR ◀ or ▶ button to select the input source.

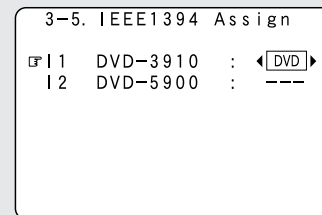

3 Press the ENTER button to enter the setting.

- The “Audio Input Setup” menu reappears.



- If you do not wish to assign the device connected by IEEE1394 cable to an input source, the IEEE1394 input can be selected by turning the **FUNCTION** knob. In this case, the connection information is cleared when the power of the connected device or the AVR-5805CI is turned off, so the selection procedure must be performed again.
- By default, if no device has been connected using an IEEE1394 cable in the past, “No Connection” is displayed.
- “Connection Change” is displayed if there is a change in the IEEE1394 connection status while this screen is displayed.
- If the model name cannot be acquired from the connected IEEE1394 device, “UNKNOWN” is displayed.
- If an IEEE1394 device other than one for IEEE1394 audio playback is connected, “Not Play” is displayed and the input source cannot be assigned.

Advanced Setup – Part 1

Setting the IEEE1394 Auto Function

- Set whether or not to automatically play the IEEE1394 device when it is selected with the **FUNCTION** knob.

1 Press the **CURSOR** Δ or ∇ button to select “IEEE1394 Auto Func.” at the “Audio Input Setup” menu, then press the **ENTER** button.

- The “IEEE1394 Auto Func.” screen appears.

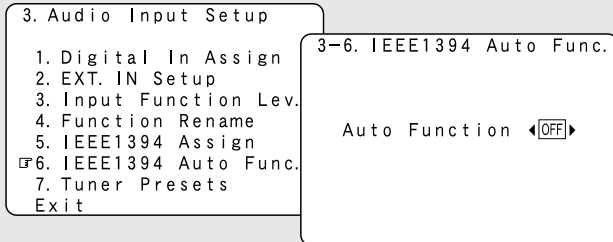

2 Press the **CURSOR** \triangleleft or \triangleright button to select “ON” or “OFF”.

ON:

Select this to automatically play the device.

OFF:

Select this if you do not want to automatically play the device.

- ※ In some cases settings may be required on your player. Also refer to the player's operating instructions.

3 Press the **ENTER** button to enter the setting.

- The “Audio Input Setup” menu reappears.

Tuner Presets

■ Auto Preset Memory

- FM stations are received automatically and stored in the memory.

1 Press the **CURSOR** Δ or ∇ button to select “Tuner Presets” at the “Audio Input Setup” menu, then press the **ENTER** button.

- The “Tuner Presets” screen appears.

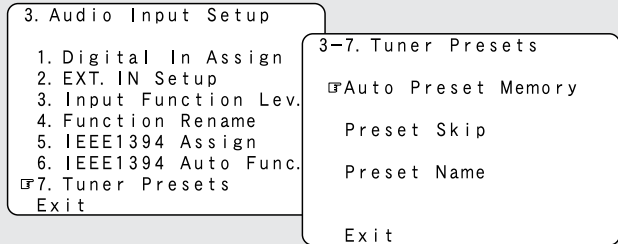

2 Press the **CURSOR** Δ or ∇ button to select “Auto Preset Memory”, then press the **ENTER** button.

- Switch to the “Auto Preset Memory” screen.

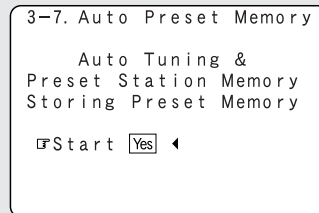

3 Press the **CURSOR** \triangleleft button to select “Yes”.

- “Search” flashes on the screen and searching begins.
- “Completed” appears once searching is completed.
- The display automatically switches to the “Tuner Presets” screen.



- If an FM station cannot be preset automatically due to poor reception, use the “Manual tuning” operation (🔍 page 66) to tune in the station, then preset it using the manual “Preset memory” operation (🔍 page 66).

■ **Preset Skip**

- Preset channels that are not used often can be skipped.

1 Press the **CURSOR** Δ or ∇ button to select “Preset Skip” at the “Tuner Presets” screen, then press the **ENTER** button.

- Switch to the “Preset Skip” screen.

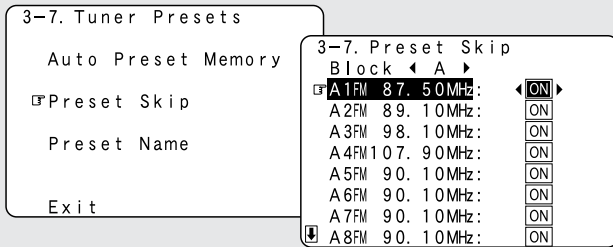

2 Press the **CURSOR** Δ or ∇ button to select the preset channel you want to skip, then press the **CURSOR** \triangleleft or \triangleright button to select “ON” or “OFF”.

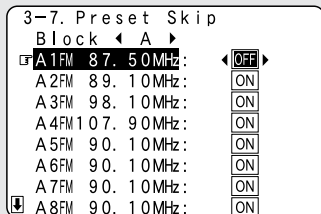

3 Press the **CURSOR** ∇ button at the very bottom of the screen to select the next preset memory block.

- The screen for the next preset memory block appears.
- ※ It is also possible to select the desired preset memory block by selecting “Block” then pressing the **CURSOR** \triangleleft or \triangleright button.

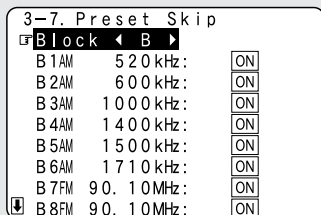

4 Repeat steps 2 and 3.

5 Press the **ENTER** button.

- The “Tuner Presets” screen reappears.

■ **Preset Name**

- The preset channels can be given the names you want. (Except the XM channels.)

1 Press the **CURSOR** Δ or ∇ button to select “Preset Name” at the “Tuner Presets” screen, then press the **ENTER** button.

- Switch to the “Preset Name” screen.

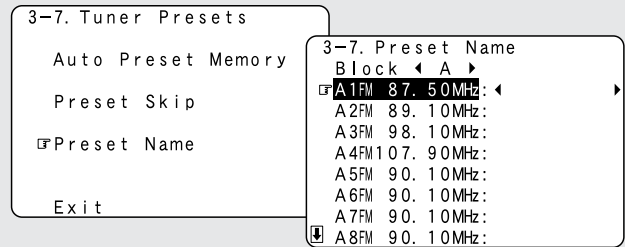

2 Press the **CURSOR** Δ or ∇ button to select the preset channel whose name you want to change, then press the **CURSOR** \triangleleft or \triangleright button.

- The screen switches to the character input screen.

Example: When “A1” is selected and the **CURSOR** \triangleleft or \triangleright button is pressed

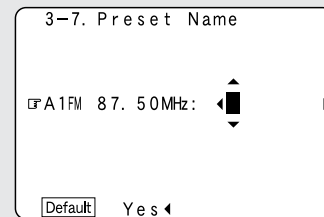

3 Press the **CURSOR** \triangleleft or \triangleright button to move the cursor (■) to the character, number, symbol or punctuation mark you wish to input, and press the **CURSOR** Δ or ∇ button to select that character.

ABCDEFGHIJKLMNOPQRSTUVWXYZ
 XYZabcdefghijklmnopqrstuvwxyz
 z0123456789
 ! " # % & ' () * + , - . / : ; < = > ? @ [\] (space)

- ※ Up to 8 characters can be input.

4 Repeat step 3 to input the preset channel name.

- ※ To reset the preset channel name to the default value, press the **CURSOR** ◀ or ▶ button to highlight the preset channel display, then press the **CURSOR** ▾ button. When “Default Yes” is selected, then press the **CURSOR** ◀ button to reset to the default name.

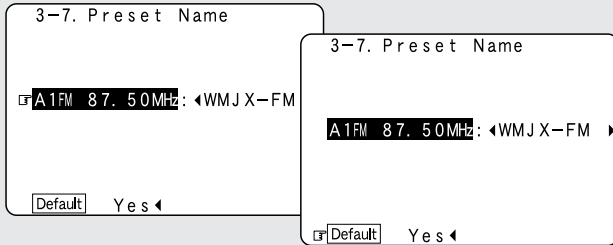

5 Once all the characters have been input, press the **ENTER** button.

- The “Preset Name” screen reappears.
- ※ Use the same procedure to change other input station names as well.

6 Press the **CURSOR** ▾ button at the very bottom of the screen to select the next preset memory block.

- The screen for the next preset memory block appears.

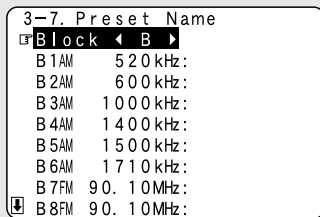

- ※ It is also possible to select the desired preset memory block by selecting “Block” then pressing the **CURSOR** ◀ or ▶ button.

7 Press the **ENTER** button to enter the setting.

- The “Tuner Presets” screen reappears.

8 Press the **CURSOR** △ or ▾ button to select “Exit”, then press the **ENTER** button.

- The “Audio Input Setup” menu reappears.

9 Press the **CURSOR** △ or ▾ button to select “Exit”, then press the **ENTER** button.

- The “System Setup Menu” reappears.

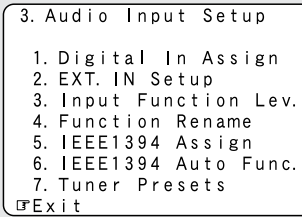

Video Setup

- Make the video-related settings.

Setting the HDMI/DVI In Assignment

- The HDMI or DVI-D input terminals are assigned for the different input sources.
Select HDMI or DVI-D for the monitor output terminal.
Select the HDMI audio signal playback method.

1 Press the **CURSOR** Δ or ∇ button to select “Video Setup” at the “System Setup Menu”, then press the **ENTER** button.

- The “Video Setup” menu appears.

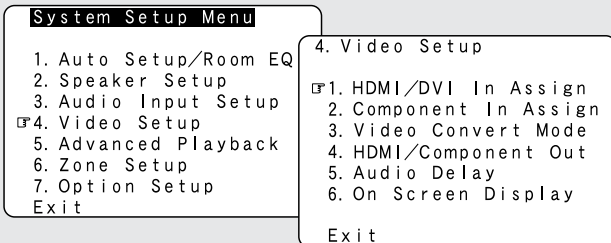

2 Press the **CURSOR** Δ or ∇ button to select “HDMI/DVI In Assign”, then press the **ENTER** button.

- The “HDMI/DVI In Assign” screen appears.

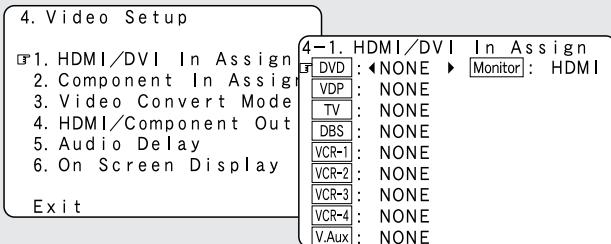

3 Press the **CURSOR** Δ or ∇ button to select the input source, then press the **CURSOR** \triangleleft or \triangleright button to select the input terminal.

- ※ Select from among HDMI 1 to 5 and DVI-D.
- ※ If the same HDMI or DVI-D input terminal is selected, the setting for the input source that was previously assigned switches to “NONE”.

4 Press the **CURSOR** Δ or ∇ button to select “Monitor”, then press the **CURSOR** \triangleleft or \triangleright button to select the monitor output terminal.

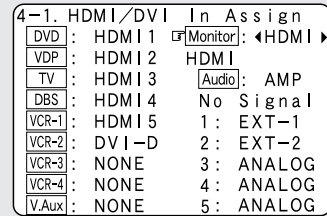

- ※ This setting can be switched directly using the **MONITOR SELECT** button on the main unit.

5 Press the **CURSOR** Δ or ∇ button to select “Audio”, then press the **CURSOR** \triangleleft or \triangleright button to select the method for playing the audio signals included in the HDMI input signal.

AMP:

Play the audio signals on speakers connected to the AVR-5805CI.

TV:

Play the audio signals on a TV connected to the AVR-5805CI.

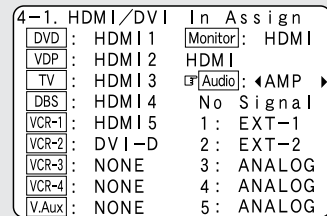

6 Press the **CURSOR** Δ or ∇ button to select the input (1 to 5), then press the **CURSOR** \triangleleft or \triangleright button to select the analog input terminal (EXT. IN or ANALOG).

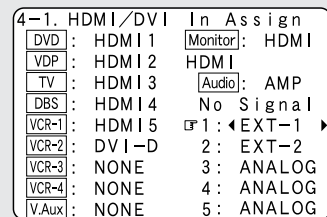

- ※ If there is no HDMI audio signal or the audio signal of HDMI can not be reproduced, the signal automatically switches to the input from the set terminal.
- ※ 1~5 correspond to each HDMI 1~5 input terminal.

Advanced Setup – Part 1

7 Press the **ENTER** button to enter the setting.

- The “Video Setup” menu reappears.



- Audio signals input from the analog and digital terminals are not output to the TV.
- With HDMI, the video and audio signals are transferred simultaneously. When HDMI is assigned to an input source, the digital audio input assignment switches to HDMI along with the video input.

When this setting is made for input sources to which a digital audio input (DENON LINK, IEEE1394 etc.) is previously assigned, the digital audio assignment is set to HDMI.

In this case, reassign the digital input using the procedure described at “Digital In Assign” (👉 page 104) and “IEEE1394 Assign” (👉 page 107).

Setting the Component In Assignment

- This assigns the component (color difference) video input terminals for the different input sources.

1 Press the **CURSOR** Δ or ∇ button to select “Component In Assign” at the “Video Setup” menu, then press the **ENTER** button.

- The “Component In Assign” screen appears.

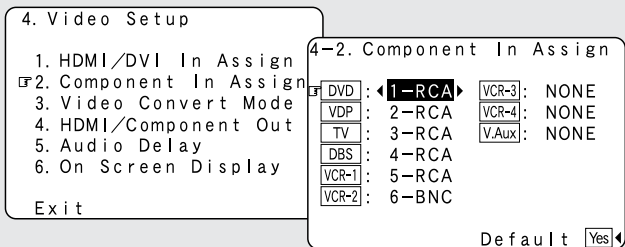

2 Press the **CURSOR** Δ or ∇ button to select the input source, then press the **CURSOR** \triangleleft or \triangleright button to select the component video input terminal.

- ※ Select from among 1-RCA to 5-RCA and 6-BNC.
- ※ If the same component video input terminal is selected, the setting for the input source that was previously assigned switches to “NONE”.
- ※ When “Default Yes” is selected, then press the **CURSOR** \triangleleft button to reset to the default values.

3 Press the **ENTER** button to enter the setting.

- The “Video Setup” menu reappears.

Setting the Video Convert Mode

- This sets whether or not to use the video conversion function.

1 Press the **CURSOR** Δ or ∇ button to select “Video Convert Mode” at the “Video Setup” menu, then press the **ENTER** button.

- The “Video Convert Mode” screen appears.

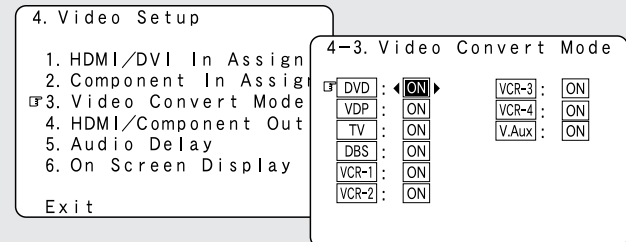

2 Press the **CURSOR** Δ or ∇ button to select the input source, then press the **CURSOR** \triangleleft or \triangleright button to select “ON” or “OFF”.

ON:

When there are multiple input signals, the input signals are detected and the input signal to be output from the video monitor output terminal is selected automatically in the following order: component video, S-Video, composite video.

OFF:

The convert function does not operate. In such cases, the input device’s cable type must be the same as the type of cable connected to the AVR-5805CI’s monitor output terminal (video, S-Video or component video).

3 Press the **ENTER** button to enter the setting.

- The “Video Setup” menu reappears.



- Down-converting from the component video signal to the S-Video and composite video signal is possible only when the resolution of a component video signal is 480i / 576i.
- When a non-standard video signal from a game machine or some other source is input, the video conversion function might not operate. If this happens, please set the conversion mode to “OFF”.
- When the video conversion function has been used, information such as that of text broadcasts which has been added to the video signal might not be output. If this happens, please set the conversion mode to “OFF”.

Setting the HDMI/Component Out Setup

- Set the format of the signal up-converted to the HDMI monitor output or component video output terminal.

1 Press the **CURSOR** Δ or ∇ button to select “HDMI/Component Out” at the “Video Setup” menu, then press the **ENTER** button.

- The “HDMI/Component Out” screen appears.

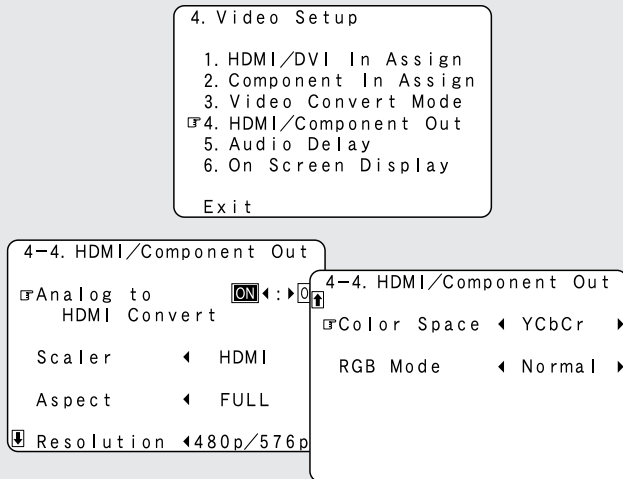

2 Press the **CURSOR** Δ or ∇ button to select the setting, then press the **CURSOR** \triangleleft or \triangleright button to select the parameter.

Analog to HDMI Convert:

- ON:** Setting for converting analog video signals into HDMI signals.
- OFF:** Setting for not converting analog video signals into HDMI signals.

Scaler:

- HDMI:** The i/p scaler can be used when outputting the input analog video signal to the HDMI monitor output terminal.
- Component:** The i/p scaler can be used when outputting the input analog video signal to the component video output terminal.
- ※ When “Analog to HDMI Convert” is set to “OFF”, the “Scaler” setting is automatically set to “Component” and fixed there.

Aspect:

- FULL:** The video is output while maintaining the aspect ratio of the input video. This mode is suited for playing back 16:9 video.
- NORMAL:** A black band is added to the left and right of the input video and the video is output. This mode is suited for playing back 4:3 video.

Resolution:

- 480p/576p:** When the video signal being input is a video, S-Video or 480i/576i component video signal, the resolution is converted to 480p/576p and the signal is output from the HDMI MONITOR OUT terminal.
- 1080i:** When the video signal input is a video, S-Video or 480i/576i/480p/576p component video signal, the resolution is converted to 1080i and the signal is output from the HDMI MONITOR OUT terminal.
- 720p:** When the video signal input is a video, S-Video or 480i/576i/480p/576p component video signal, the resolution is converted to 720p and the signal is output from the HDMI MONITOR OUT terminal.
- 1080p:** The input video signal is converted to a resolution of 1080p for output. This cannot be selected when “Scaler” is set to “Component”.
- Through:** The video signal input is output as such from the HDMI MONITOR OUT terminal without being converted.

Color Space:

- Y Cb Cr:** The Y Cb Cr format video signals is output via the HDMI output terminal.
- RGB:** The RGB format video signals is output via the HDMI output terminal.

RGB Mode Setup:

- Normal:** Signals are output via the HDMI output terminal with a digital RGB video range (data range) of 16 (black) to 235 (white).
- Enhanced:** Signals are output via the HDMI output terminal with a digital RGB video range (data range) of 0 (black) to 255 (white). When the HDMI terminal is connected, the black may seem to stand out, depending on the TV or the monitor. In this case, set this to “Enhanced”.

- ※ When “Y Cb Cr” is selected under “Color Space”, “RGB Mode Setup” will have no effect.
- ※ The “Aspect” setting is valid when the resolution is set to 1080i, 720p or 1080p. To output with other resolutions, set the aspect ratio on the TV.
- ※ When “Through” is set, the signal is output with the same resolution as input from the video, S-Video and component video terminals. The OSD, however, is output with a resolution of 480i, so use a monitor compatible with this resolution.

3 Press the **ENTER** button to enter the setting.

- The “Video Setup” menu reappears.

Advanced Setup – Part 1



- “Color Space” and “RGB Mode Setup” are only displayed when “Analog to HDMI Convert” is set to “ON”.
- When connecting to an HDCP compatible monitor equipped with DVI-D terminal using an HDMI/DVI-D converter cable, the signals are output in RGB format, regardless of the “Color Space” setting.
- To view the on screen display using an HDMI monitor, set “Analog to HDMI Convert” at “HDMI/Component Out” to “ON” (default).
- Set the resolution of the video output to one that is compatible with the resolution of your monitor.
- When “Scaler” is set to “Component” and the video input signal includes copyright protection data, the signal is output from the component video output terminal with a resolution of 480p/576p even if “Resolution” is set to “1080i” or “720p”.

Setting the Audio Delay

- Set the audio delay timing to synchronize the sound and video.

1 Press the **CURSOR** Δ or ∇ button to select “Audio Delay” at the “Video Setup” menu, then press the **ENTER** button.

- The “Audio Delay” screen appears.

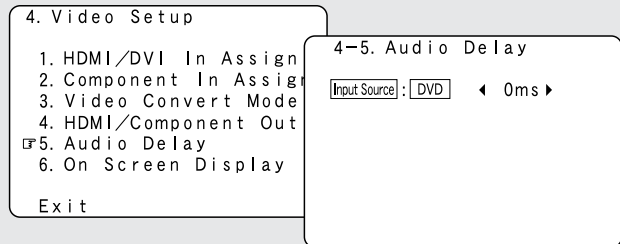

2 Press the **CURSOR** \triangleleft or \triangleright button to set the delay time (0 ms ~ 200 ms).

- ※ With a movie source, for example, adjust so that the movement of the actors' lips is synchronized with the sound.

3 Press the **ENTER** button to enter the setting.

- The “Video Setup” menu reappears.



- The audio delay setting does not apply when playing in the EXT. IN mode or in the analog input DIRECT mode or STEREO mode (only when the crossover frequency is set to “FIXED-THX-” or front speaker is set to “Large” (TONE DEFEAT “ON”, Room EQ “OFF”).

Setting the On Screen Display (OSD)

- Use this to turn the on screen display (messages other than the menu screens) on or off.
- Sets the on screen display's display mode.

1 Press the **CURSOR** Δ or ∇ button to select “On Screen Display” at the “Video Setup” menu, then press the **ENTER** button.

- The “On Screen Display” screen appears.

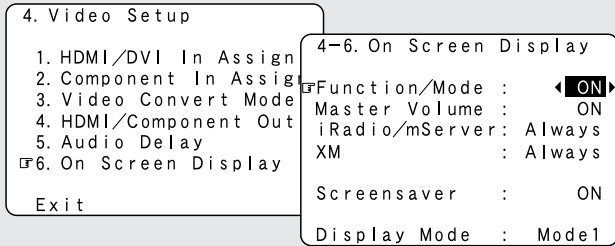

2 Press the **CURSOR** Δ or ∇ button to select the item to be set, then press the **CURSOR** \triangleleft or \triangleright button to select the parameter.

Function/Mode Status:

Set whether or not to turn on the on screen display of the input source name and input mode when an input source is selected.

Master Volume Status:

Set whether or not to turn on the on screen display of the main volume level when the main volume is operated.

iRadio/mServer:

Set the time for which the on screen display is displayed when performing Internet radio and Music server operations.

Always: The on screen display is always on. (Default)

5sec: The on screen display turns off 5 seconds after it turns on.

10sec: The on screen display turns off 10 seconds after it turns on.

OFF: The on screen display is not displayed.

XM:

Set the time for which the on screen display is displayed when performing XM operations.

Always: The on screen display is always on. (Default)

5sec: The on screen display turns off 5 seconds after it turns on.

10sec: The on screen display turns off 10 seconds after it turns on.

OFF: The on screen display is not displayed.

Screensaver:

ON: The screensaver is launched if no operation is performed for approximately 3 minutes.

OFF: The screensaver is not launched.

Display Mode:

• Mode 1:

Flickering is not prevented.

• Mode 2:

Prevents flickering of the on screen display when there is no video signal.

Use this mode if the on screen display does not appear in the Mode 1, as may happen according to the TV being used.

3 Press the **ENTER** button to enter the setting.

- The “Video Setup” menu reappears.

4 Press the **CURSOR** Δ or ∇ button to select “Exit”, then press the **ENTER** button.

- The “System Setup Menu” reappears.

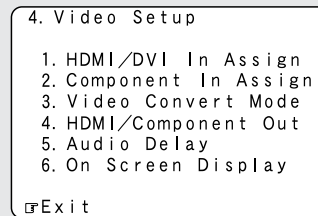

- The screensaver is launched while in the Internet radio, Music server or XM mode if the on screen display's display time is set to “Always”.

Advanced Playback

- Makes more detailed audio playback settings.

Setting the 2ch Direct/Stereo

- The speaker settings can be changed specifically for playing in the 2 channel DIRECT or STEREO mode.

1 Press the **CURSOR** Δ or ∇ button to select “Advanced Playback” at the “System Setup Menu”, then press the **ENTER** button.

- The “Advanced Playback” menu appears.

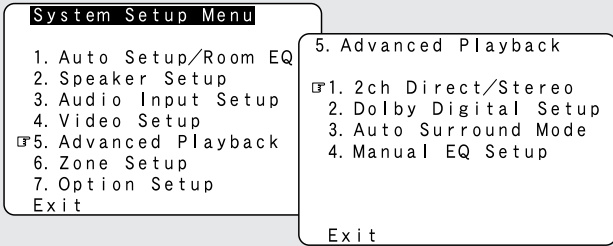

2 Press the **CURSOR** Δ or ∇ button to select “2ch Direct / Stereo”, then press **ENTER** button.

- The “2ch Direct/Stereo” screen appears.

Example: This screen is displayed in function of the settings made at “Speaker Configuration”, “Subwoofer Setup”, “Delay Time” and “Crossover Frequency”

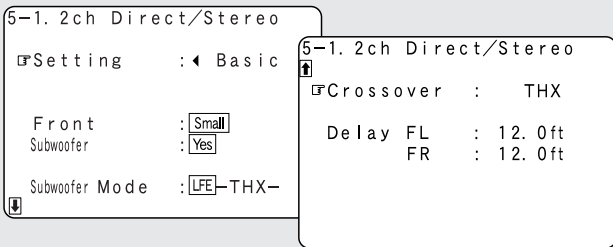

3 Press the **CURSOR** \triangleleft or \triangleright button to select “Custom”.

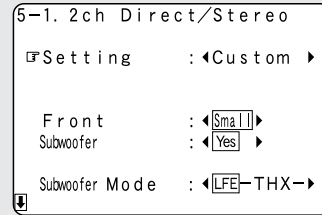

4 Press the **CURSOR** Δ or ∇ button to select the item, then press **CURSOR** \triangleleft or \triangleright button to set.

- ※ For a description of the settings for the different items, see pages 140 ~ 146.

5 Press the **ENTER** button to enter the setting.

- The “Advanced Playback” menu reappears.

Setting the front B speakers when the surround mode is set to the 2 channel Direct or Stereo

- When “Adv+Front B” is selected at “Power Amp Assign” and “Custom” is selected at this setting, the “Front B” setting is displayed.
- ※ To play signals from the Front B speaker when in the 2 channel Direct or Stereo mode, set “Used”.

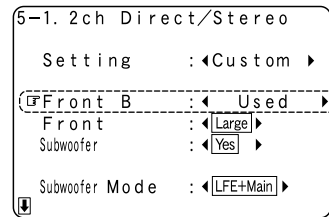

Setting the Dolby Digital Setup

- Turn the audio compression on or off when down-mixing Dolby Digital signals.

1 Press the **CURSOR** Δ or ∇ button to select “Dolby Digital Setup” at the “Advanced Playback” menu, then press the **ENTER** button.

- The “Dolby Digital Setup” screen appears.

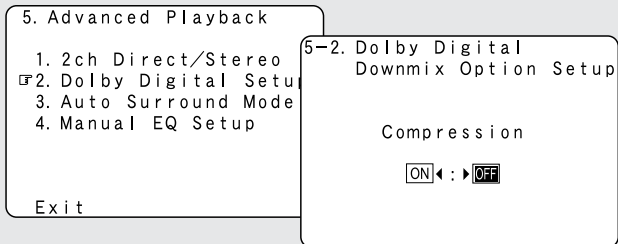

2 Press the **CURSOR** \triangleleft or \triangleright button to select “ON” or “OFF”.

ON:

The dynamic range is compressed automatically according to the combination of speakers being used.

OFF:

The dynamic range is not compressed.

- ※ Set “Compression” to “ON” if it seems that sound is distorted because the input level exceeds the allowable input for the front speakers.
- ※ When a center speaker or surround speakers are not connected, the sounds in those channels are directed to the front speakers.

3 Press the **ENTER** button to enter the setting.

- The “Advanced Playback” menu reappears.

Setting the Auto Surround Mode

- The surround mode used at last for the four types of input signals shown below is stored in the memory, and the signal is automatically played with that surround mode the next time it is input.

Note that the surround mode setting is also stored separately for the different input sources.

- ① Analog and PCM 2 channel signals (STEREO)
 - ② 2 channel signals of Dolby Digital, DTS or other multi-channel format (DOLBY PLIIx Cinema)
 - ③ Multi-channel signals of Dolby Digital, DTS or other multi-channel format (DOLBY/DTS SURROUND)
 - ④ PCM and DSD multi-channel signals other than Dolby Digital and DTS (MULTI CH IN)
- ※ Default settings are indicated in ().
- ※ During playback in the PURE DIRECT mode, the surround mode does not change even if the input signal is changed.

1 Press the **CURSOR** Δ or ∇ button to select “Auto Surround Mode” at the “Advanced Playback” menu, then press the **ENTER** button.

- The “Auto Surround Mode” screen appears.

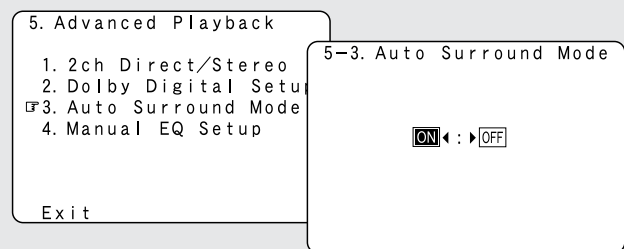

2 Press the **CURSOR** \triangleleft or \triangleright button to select “ON” if you want to use the auto surround mode, “OFF” if you do not want to use it.

3 Press the **ENTER** button to enter the setting.

- The “Advanced Playback” menu reappears.



- The various settings applied in the auto surround mode can be checked via the on screen display. Simply press the **ON SCREEN** button ( page 52).

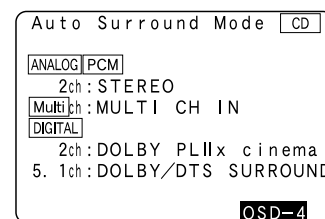

Advanced Setup – Part 1

Setting the Manual EQ Setup

- Allows you to adjust the tonal quality of the various speakers (except the subwoofer) while listening to a music source.

1 Press the **CURSOR** Δ or ∇ button to select “Manual EQ Setup” at the “Advanced Playback” menu, then press the **ENTER** button.

- The “Manual EQ” screen appears.

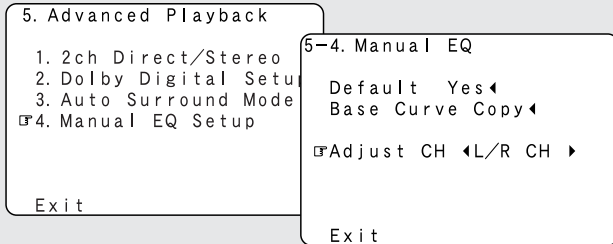

2 Press the **CURSOR** \triangleleft or \triangleright button to select the adjustment mode, then press the **ENTER** button.

All CH:

All channels can be adjusted simultaneously.

L/R CH:

The left and right channels of the pair of speakers can be adjusted simultaneously.

Each CH:

The channels can be adjusted separately.

3 Press the **CURSOR** \triangleleft or \triangleright button to select the speaker to be set.

Example: When “L/R CH” is selected.

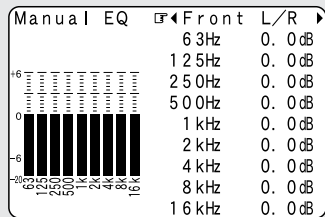

※ The display changes as follows.

① Select the “L/R CH”

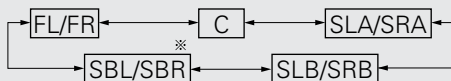

② Select the “Each CH”

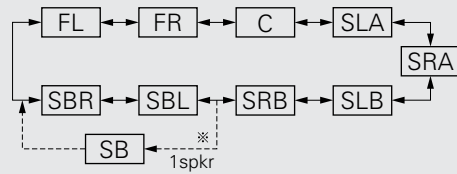

※ When the surround back speaker setting is set to “1spkr” at “Speaker Configuration”, this is set to “SB”.

③ Select the “All CH”

In this case, speaker selection is not performed.

※ If a value is already set for the FL channel, the data stored for the FL channel is displayed.

4 Press the **CURSOR** Δ or ∇ button to select the frequency, then press the **CURSOR** \triangleleft or \triangleright button to adjust the gain level.

※ Each frequency can be adjusted the range from -20.0 dB to $+6.0$ dB in 0.5 dB step.

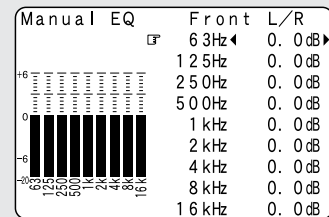

5 Press the **ENTER** button to enter the setting.

- The “Manual EQ” screen reappears.

6 Press the **CURSOR** Δ or ∇ button to select “Exit”, then press the **ENTER** button.

- The “Advanced Playback” menu reappears.

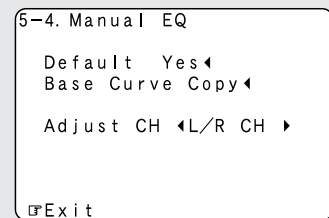

7 Press the **CURSOR** Δ or ∇ button to select “Exit”, then press the **ENTER** button.

- The “System Setup Menu” reappears.

```

5. Advanced Playback
  1. 2ch Direct/Stereo
  2. Dolby Digital Setup
  3. Auto Surround Mode
  4. Manual EQ Setup
  [F]Exit
    
```



- “Base Curve Copy” is displayed after performing the Auto Setup.
- To restore the settings to their defaults, select “Default Yes \blacktriangleleft ”, then press the **CURSOR** \blacktriangleleft button.

```

5-4. Manual EQ
  [F]Default Yes $\blacktriangleleft$ 
  Base Curve Copy $\blacktriangleleft$ 
  Adjust CH  $\blacktriangleleft$ L/R CH  $\blacktriangleright$ 
  Exit
    
```

■ Procedure for copying the “Flat” correction curve

1 Press the **CURSOR** Δ button to select “Base Curve Copy”, then press the **CURSOR** \blacktriangleleft button.

- Switch to the “Base Curve Copy” screen.

```

5-4. Manual EQ
  Default Yes $\blacktriangleleft$ 
  [F]Base Curve Copy $\blacktriangleleft$ 
  Adjust CH  $\blacktriangleleft$ L/R CH  $\blacktriangleright$ 
  Exit
  5-4. Manual EQ
  Curve: -Flat-
  [F]Base Curve Copy?
  [Yes] $\blacktriangleleft$ : $\blacktriangleright$ [No]
    
```

2 Press the **CURSOR** \blacktriangleleft button to select “Yes”.

```

5-4. Manual EQ
  Curve: -Flat-
  Base Curve Copy?
  [F]Yes $\blacktriangleleft$ : $\blacktriangleright$ [No]
    
```

3 Press the **ENTER** button to enter the setting.

- The “Manual EQ” screen reappears.

```

5-4. Manual EQ (-Flat-)
  Default Yes $\blacktriangleleft$ 
  Base Curve Copy $\blacktriangleleft$ 
  [F]Adjust CH  $\blacktriangleleft$ L/R CH  $\blacktriangleright$ 
  Exit
    
```

- ※ The type of the copied correction curve is displayed in the upper right of this screen.



- If the “Auto Setup” procedure has not been performed, this item is not displayed.

Advanced Setup – Part 1

Zone Setup (ZONE2 = 5.1/7.1ch)

- Make the settings related to surround playback and video for ZONE2.
- Adjust the sound played in ZONE3 and ZONE4.



- When “STEREO” or “MONO” is selected for the ZONE2 channel output setting at “Channel Setup” (👉 page 126 ~ 128), the menu screen displayed differs. In this case, see the instructions starting at page 125.

Setting the type of speakers for ZONE2

- Set the presence/absence of speaker combinations and the size in function of the low frequency reproduction capabilities when playing surround sound in ZONE2.

- 1 Press the **CURSOR** Δ or ∇ button to select “Zone Setup” at the “System Setup Menu”, then press the **ENTER** button.

- The “Zone Setup” menu appears.

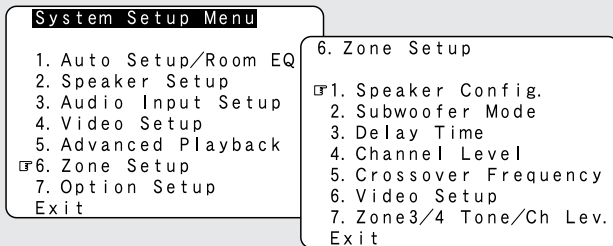

- 2 Press the **CURSOR** Δ or ∇ button to select “Speaker Config.”, then press the **ENTER** button.

- The “Speaker Config.” screen appears.

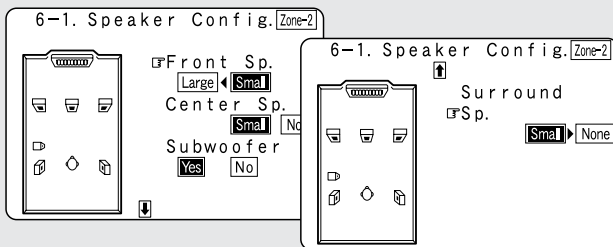

- 3 Press the **CURSOR** Δ or ∇ button to select the speaker, then press the **CURSOR** \triangleleft or \triangleright button to select the parameter.

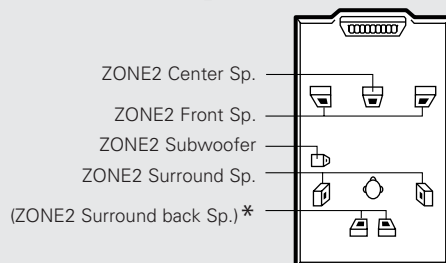

* This is only displayed when “7.1ch” is selected for the ZONE2 channel output setting at “Channel Setup” (👉 page 126 ~ 128).

※ For a description of the different parameters (👉 page 141).

- 4 Press the **ENTER** button to enter the setting.

- The “Zone Setup” menu reappears.

Setting the low frequency distribution for ZONE2

- This selects the subwoofer used in ZONE2 for playing the low base sound.

- 1 Press the **CURSOR** Δ or ∇ button to select “Subwoofer Mode” at the “Zone Setup” menu, then press the **ENTER** button.

- The “Subwoofer Mode” screen appears.

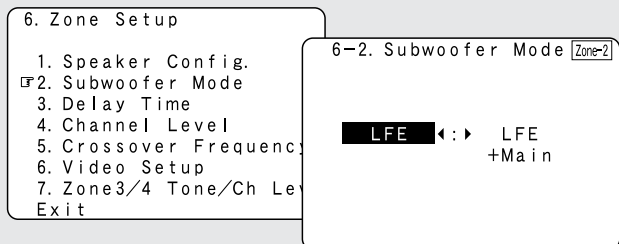

- 2 Press the **CURSOR** \triangleleft or \triangleright button to select the setting.

LFE:

For any channel(s) that are set to LARGE, low frequencies in that channel’s corresponding source are directed to that loudspeaker only. Low frequencies that are directed to the subwoofer(s) are from the program source LFE channel, and from other channels where the speakers are set to SMALL.

LFE+Main:

Low frequencies from speaker channels that have been set to LARGE are reproduced from those speakers as well as from the subwoofer(s). Depending upon the characteristics of the LARGE main speakers, this mode may provide a more even low frequency response throughout the listening room.

- 3 Press the **ENTER** button to enter the setting.

- The “Zone Setup” menu reappears.



- The subwoofer mode setting is only valid when “Large” is set for the ZONE2 front speakers and “Yes” is set for the subwoofer in the “Setting the type of speaker for ZONE2”.

Setting the Delay Time for ZONE2

- This parameter is for optimizing the timing of the sound produced from the various speakers and subwoofer according to the listening position in ZONE2.

1 Press the **CURSOR** Δ or ∇ button to select “Delay Time” at the “Zone Setup” menu, then press the **ENTER** button.

- The “Delay Time” screen appears.

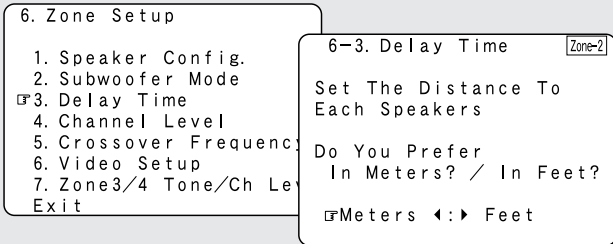

2 Press the **CURSOR** \triangleleft or \triangleright button to select the desired unit, “Meters” or “Feet”.

- The “Delay Time” screen appears automatically.

Example: When “Feet” is selected

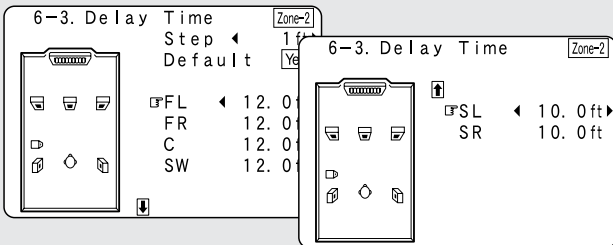
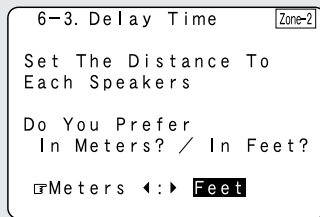

3 Press the **CURSOR** Δ or ∇ button to select the speaker to be set.

4 Press the **CURSOR** \triangleleft or \triangleright button to set the distance between the center speaker and listening position.

Example: When the distance is set to 10.0 feet for the center speaker

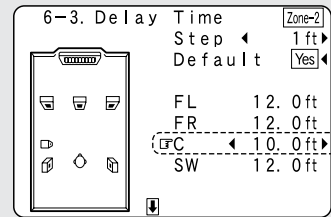

- The distance changes in units of 1 foot or 0.1 foot each time the button is pressed. Select the value closest to the measured distance.
- When “Step” is selected, you can select the unit of “1 ft (0.1 m)” or “0.1 ft (0.01 m)”.
- When “Default Yes” is selected, then press the **CURSOR** \triangleleft button to reset to the default values.
- The difference of the distances set for the various speakers must be 20.0 ft (6.0 m) or under. If an inappropriate distance is set, “RELOCATE BLINKING SP!” is displayed. In this case, move the relevant speaker to the proper position as indicated by the displayed value.**

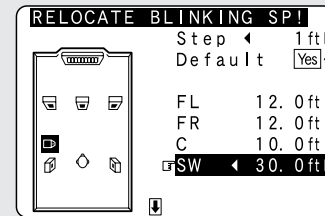

5 Press the **ENTER** button to enter the setting.

- The “Zone Setup” menu reappears.

- The AVR-5805CI automatically sets the optimum surround delay time for the ZONE2 listening room.

Advanced Setup – Part 1

Setting the Channel Level for ZONE2

- Use this setting to adjust so that the playback level between the different channels of ZONE2 is equal.
- From the ZONE2 listening position, listen to the test tones produced from the speakers used in ZONE2 to adjust the level.
- The level can also be adjusted directly from the remote control unit (📖 page 95).

1 Press the **CURSOR** Δ or ∇ button to select “Channel Level” at the “Zone Setup” menu, then press the **ENTER** button.

- The “Channel Level” screen appears.

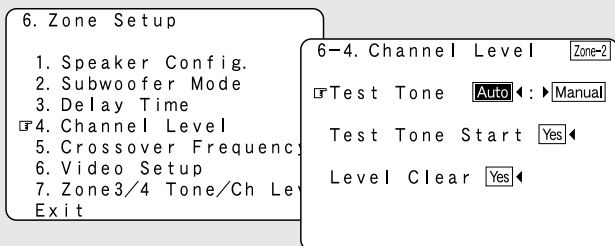

2 Press the **CURSOR** \leftarrow or \rightarrow button to select “Auto” or “Manual”.

Auto:

Adjust the level while listening to the test tones produced automatically from each speaker.

Manual:

Select the speaker from which you want to produce the test tone to adjust the level.

Example: When the “Auto” mode is selected

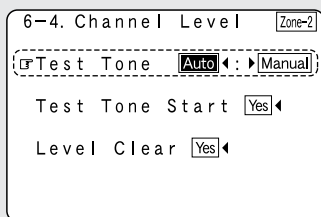

3 Press the **CURSOR** Δ or ∇ button to select “Test Tone Start”, then press the **CURSOR** \leftarrow button to select “Yes”.

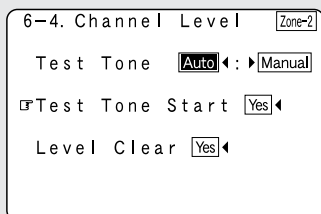

4-1 When “Auto” mode is selected: Press the **CURSOR** \leftarrow or \rightarrow button to adjust all the speakers to the same volume.

- The test tones are emitted from each speaker in the following order, at 4 seconds intervals the first time and second time around, 2 seconds intervals the third time around and on:

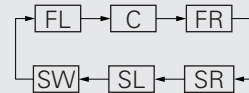

Example: When the volume is set to -11.5 dB while the test tone is being produced from the Front L ch speaker

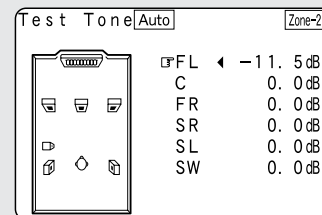

- The volume can be adjusted between -12.0 dB and $+12.0$ dB in units of 0.5 dB.

4-2 When “Manual” mode is selected: Press the **CURSOR** Δ or ∇ button to select the speaker used in ZONE2, then press the **CURSOR** \leftarrow or \rightarrow button to adjust all the speakers to the same volume.

Example: “Manual” mode is selected.

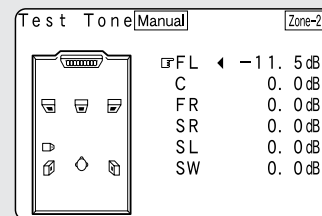

5 Press the **ENTER** button to enter the setting.

- The “Channel Level” screen reappears.



- To cancel the settings, press the **CURSOR** \leftarrow button to select “Level Clear” and “Yes” on the “Channel Level” screen, then make the settings again.

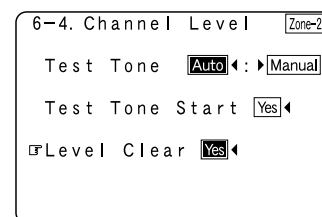

- When adjusting the level of an active subwoofer system, you may also need to adjust the subwoofer's own volume control.
- When you adjust the channel levels while in the SYSTEM SETUP CHANNEL LEVEL mode, the channel level adjustments made will affect all surround modes for ZONE2.
- After you have completed the SYSTEM SETUP CHANNEL LEVEL adjustments, you can then activate the individual surround modes and adjust channel levels that will be remembered for each of those modes. Then, whenever you activate a particular surround sound mode, your preferred channel level adjustments for just that mode will be recalled. Check the instructions for adjusting channel levels within each surround mode (page 95, 96).
- You can adjust the channel levels for each of the following surround modes for ZONE2: STEREO, STANDARD (DOLBY/DTS SURROUND), 5/7 CH STEREO, WIDE SCREEN, SUPER STADIUM, ROCK ARENA, JAZZ CLUB, CLASSIC CONCERT, MONO MOVIE, VIDEO GAME, MATRIX and VIRTUAL.

Setting the Crossover Frequency for ZONE2

- Set the frequency (in Hz) below which deep bass appearing in the main channels will be routed to the ZONE2 subwoofer.

1 Press the **CURSOR** Δ or ∇ button to select “Crossover Frequency” at the “Zone Setup” menu, then press the **ENTER** button.

- The “Crossover Frequency” screen appears.

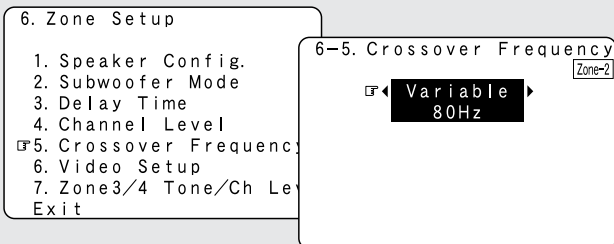

2 Press the **CURSOR** \triangleleft or \triangleright button to select the frequency.

VARIABLE 40, 60, 80, 100, 120, 150, 200, 250 Hz:

Set as desired according to your speakers' bass playback ability.

3 Press the **ENTER** button to enter the setting.

- The “Zone Setup” menu reappears.



- For the majority of home theater speaker systems, we recommend that the crossover frequency be set to 80 Hz. When using very compact speakers, however, it may be advantageous to select a higher crossover frequency. Check the specified low frequency limit of each speaker (usually published in the specifications tables in speaker owner's manuals).
- The crossover frequency mode is valid only when subwoofer is set to “Yes”, and when one or more speakers are set to SMALL, as described in section “Setting the type of speakers for ZONE2” (page 120).

Setting the Video Setup for ZONE2

Video Convert Mode (ZONE2)

- This sets whether or not to use the video conversion function.

1 Press the **CURSOR** Δ or ∇ button to select “Video Setup” at the “Zone Setup” menu, then press the **ENTER** button.

- The “Video Setup” screen appears.

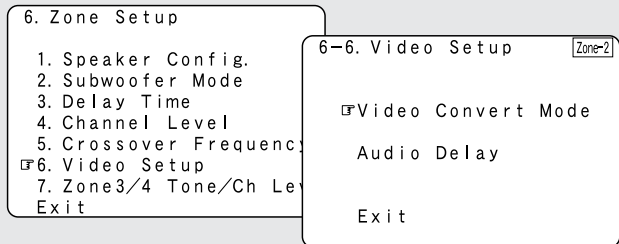

2 Press the **CURSOR** Δ or ∇ button to select “Video Convert Mode”, then press the **ENTER** button.

- The “Video Convert Mode” screen appears.

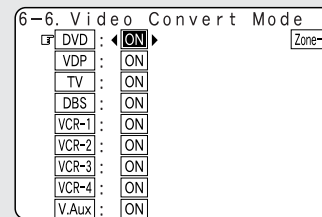

3 Press the **CURSOR** Δ or ∇ button to select the ZONE2 input source, then press the **CURSOR** \triangleleft or \triangleright button to select “ON” or “OFF”.

ON:

When there are multiple input signals for the input sources selected at ZONE2, the input signal is detected and the input signal output to the ZONE2's monitor output terminal is selected automatically, in the following order of priority: Component, S-Video, Composite.

OFF:

The convert function does not operate.

In such cases, the input device's cable type must be the same as the type of cable connected to the AVR-5805CI's monitor output terminal (video, S-Video or component video).

4 Press the **ENTER** button to enter the setting.

- The “Zone Setup” menu reappears.

Advanced Setup – Part 1

■ Audio Delay (ZONE2)

- Set the delay time the sound is synchronized with the picture which are output in ZONE2.

- 1 Press the **CURSOR** Δ or ∇ button to select “Audio Delay” at the “Video Setup” menu, then press the **ENTER** button.

- The “Audio Delay” screen appears.

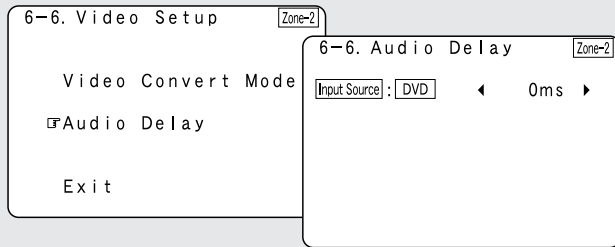

- 2 Press the **CURSOR** \triangleleft or \triangleright button to set the delay time (0 ms ~ 200 ms).

- ※ With a movie source, for example, adjust so that the movement of the actors’ lips is synchronized with the sound.

- 3 Press the **ENTER** button to enter the setting.

- The “Zone Setup” menu reappears.

Setting the ZONE3 and ZONE4 tone control and channel level

- Adjust the tone and channel level of the sound output from ZONE3 and ZONE4.

- 1 Press the **CURSOR** Δ or ∇ button to select “Zone3/4 Tone/Ch Lev.” at the “Zone Setup” menu, then press the **ENTER** button.

- The “Zone3/4 Tone/Ch Lev.” screen appears.

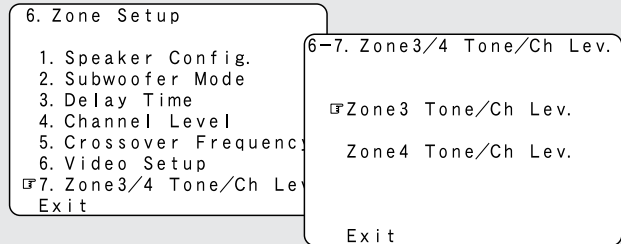

- 2 Press the **CURSOR** Δ or ∇ button to select the zone whose sound you want to adjust (ZONE3, ZONE4), then press the **ENTER** button.

- Switch to the setting screen.

Example: When “Zone3” is selected

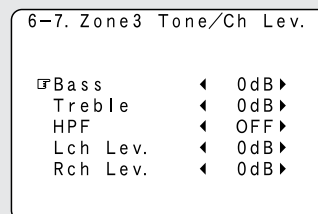

- 3 Press the **CURSOR** Δ or ∇ button to select the item to be set, then press the **CURSOR** \triangleleft or \triangleright button to adjust the parameter.

Bass:

Adjust the tone for the bass. (The bass sound can be adjusted between -12 dB and +12 dB in steps of 2.0 dB.)

Treble:

Adjust the tone for the treble. (The treble sound can be adjusted between -12 dB and +12 dB in steps of 2.0 dB.)

HPF:

Set this to “ON” if your speakers do not have a very strong capacity for producing low bass. Using the high pass filter makes it possible to reduce distortion of the bass sound.

Channel Level:

Set so that the playback level is the same for the left and right channels. (The volume can adjusted between -12 dB and +12 dB in steps of 1.0 dB.)

- 4 Press the **ENTER** button.

- The “Zone3/4 Tone/Ch Lev.” screen reappears.

- ※ Use the same procedure to make the settings for ZONE4.

5 Press the **CURSOR** Δ or ∇ button to select **“Exit”**, then press the **ENTER** button.

- The “Zone Setup” menu reappears.

```
6-7. Zone3/4 Tone/Ch Lev.

Zone3 Tone/Ch Lev.
Zone4 Tone/Ch Lev.

Exit
```

6 Press the **CURSOR** Δ or ∇ button to select **“Exit”**, then press the **ENTER** button.

- The “System Setup Menu” reappears.

■ **“Zone Setup” setting when ZONE2 is set to “STEREO” or “MONO”**

- The “Zone Setup” screen shown below is displayed when “STEREO” or “MONO” is selected for the ZONE2 channel setting at “Channel Setup”.

```
6. Zone Setup

1. Zone2 Tone/Ch Lev.
2. Zone3 Tone/Ch Lev.
3. Zone4 Tone/Ch Lev.
4. Video Setup

Exit
```

- “ZONE2 Tone/Ch Lev.” can be set in the same way as “ZONE3/ZONE4 Tone/Ch Lev.”.
- For instructions on the “Video Setup” (item 4) (👉 page 123, 124).

Option Setup

- Make other expert settings.

Setting the Channel Setup

- With this setting it is possible to change the number of channels played in the different zones according to the purpose.
The AVR-5805CI is equipped with pre-out terminals for a total of 22 channels.
16 channel of these pre-out terminals can be assigned between the MAIN ZONE and ZONE2 (Theater). In addition, up to three channels of subwoofers can be added to the MAIN ZONE, so subwoofers can be set in the front and back or at the sides. The number of channels output from the pre-out terminals exclusively for ZONE2, 3 and 4 can be set to "MONO" or "STEREO" according to the method of playback in the various multi-zones.

■ Channel setup flow

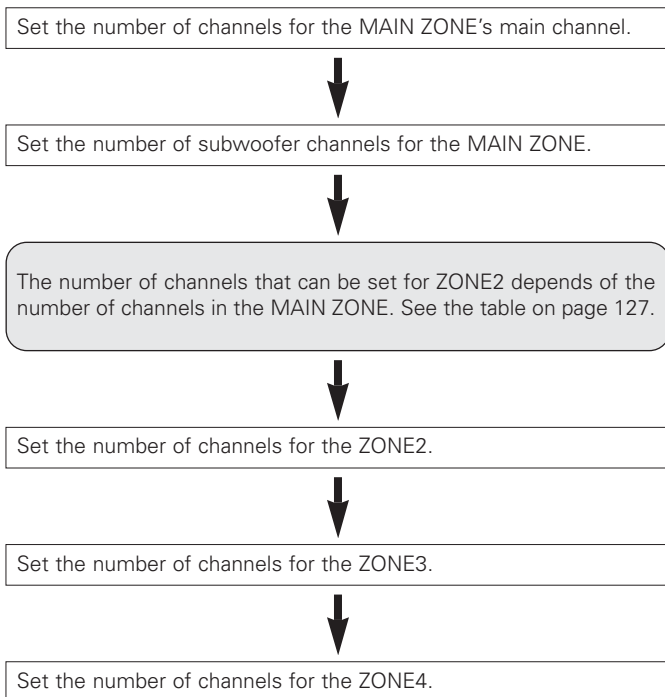

- 1 Press the **CURSOR** Δ or ∇ button to select "Option Setup" at the "System Setup Menu", then press the **ENTER** button.
 - The "Option Setup" menu appears.

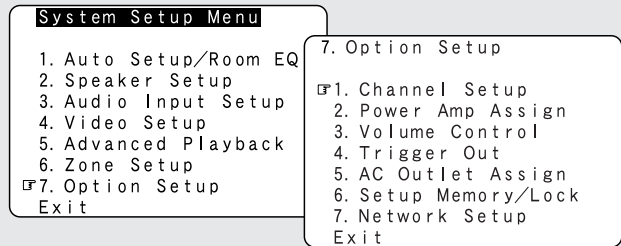

- 2 Press the **CURSOR** Δ or ∇ button to select "Channel Setup", then press the **ENTER** button.
 - The "Channel Setup" screen appears.

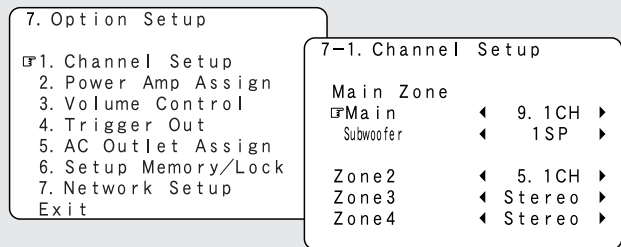

- 3 Press the **CURSOR** Δ or ∇ button to select the zone, then press the **CURSOR** \triangleleft or \triangleright button to select the channel setting.
 - ※ Refer to the table on page 127.

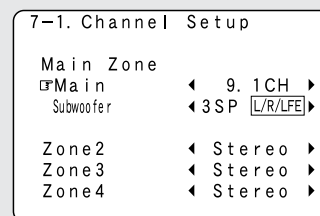

- 4 Press the **ENTER** button to enter the setting.
 - The "Option Setup" menu reappears.



■ The number of channels that can be selected for the different zones is as shown below.

MAIN ZONE		ZONE2	ZONE3	ZONE4
Main	Subwoofer			
9.1 CH	1 SP	5.1 CH / STEREO / MONO	STEREO / MONO	STEREO / MONO
	2 SP	STEREO / MONO	STEREO / MONO	STEREO / MONO
	3 SP	STEREO / MONO	STEREO / MONO	STEREO / MONO
7.1 CH	1 SP	7.1 CH / 5.1 CH / STEREO / MONO	STEREO / MONO	STEREO / MONO
	2 SP	5.1 CH / STEREO / MONO	STEREO / MONO	STEREO / MONO
	3 SP	5.1 CH / STEREO / MONO	STEREO / MONO	STEREO / MONO
5.1 CH	1 SP	7.1 CH / 5.1 CH / STEREO / MONO	STEREO / MONO	STEREO / MONO
	2 SP	7.1 CH / 5.1 CH / STEREO / MONO	STEREO / MONO	STEREO / MONO
	3 SP	7.1 CH / 5.1 CH / STEREO / MONO	STEREO / MONO	STEREO / MONO

NOTE:

- The channel settings that can be selected for ZONE2 depend on the channel settings for the MAIN ZONE.

■ The subwoofer output composition is as shown below.

Subwoofer	Output Composition	
1 SP	–	Select this when only one subwoofer is connected.
2 SP	L/R	Select this when subwoofers are installed on the left and right.
	F/B	Select this when subwoofers are installed at the front and rear.
	LFE/M	Select this to use the subwoofer for both the main channel's low frequencies and for LFE low frequencies.
3 SP	L/R/LFE	Select this when subwoofers are installed on the left and right and you are using a subwoofer specifically for the LFE.
	F/B/LFE	Select this when subwoofers are installed at the front and rear and you are using a subwoofer specifically for the LFE.



Advanced Setup – Part 1

■ Connecting the preouts

The pre-out terminals used to connect the subwoofer depends on the MAIN ZONE's channel setup. Connect as shown on the diagram below.

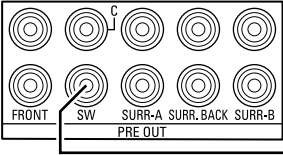
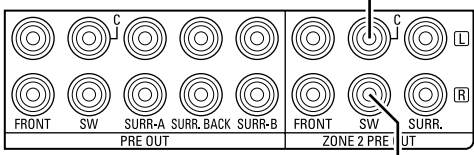
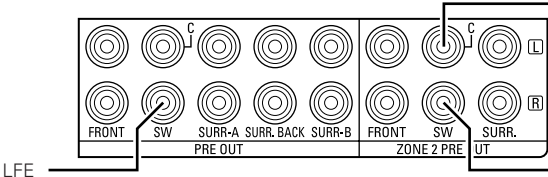
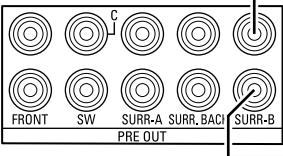
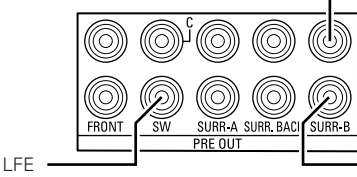
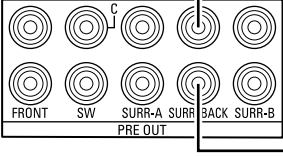
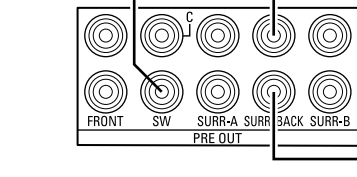
Channel Setup		Connection
Main	Subwoofer	
9.1 CH / 7.1 CH / 5.1 CH	1 SP	 <p>Subwoofer</p>
9.1 CH	2 SP	 <p>Subwoofer(L/F/M) Subwoofer(R/B/LFE)</p>
	3 SP	 <p>Subwoofer(L/F) Subwoofer(R/B) LFE</p>
7.1 CH	2 SP	 <p>Subwoofer(L/F/M) Subwoofer(R/B/LFE)</p>
	3 SP	 <p>Subwoofer(L/F) Subwoofer(R/B) LFE</p>
5.1 CH	2 SP	 <p>Subwoofer(L/F/M) Subwoofer(R/B/LFE)</p>
	3 SP	 <p>Subwoofer(L/F) Subwoofer(R/B) LFE</p>

Setting the Power Amplifier Assignment

- With the AVR-5805CI's 10-channel power amplifier, it is possible to select 10 channels worth of signals (not including the subwoofer signals output from the pre-out terminals) to be output from the speakers. This makes it possible to put together various speaker systems. The channels can be selected freely, so "L1" to "L5" and "R1" to "R5" are indicated on the speaker terminals on the AVR-5805CI's rear panel.
- The channels for which the power amplifier can be assigned differ according to the channel settings made at "Channel Setup" (🔧 page 126 ~ 128).

■ Power amplifier assignment flow

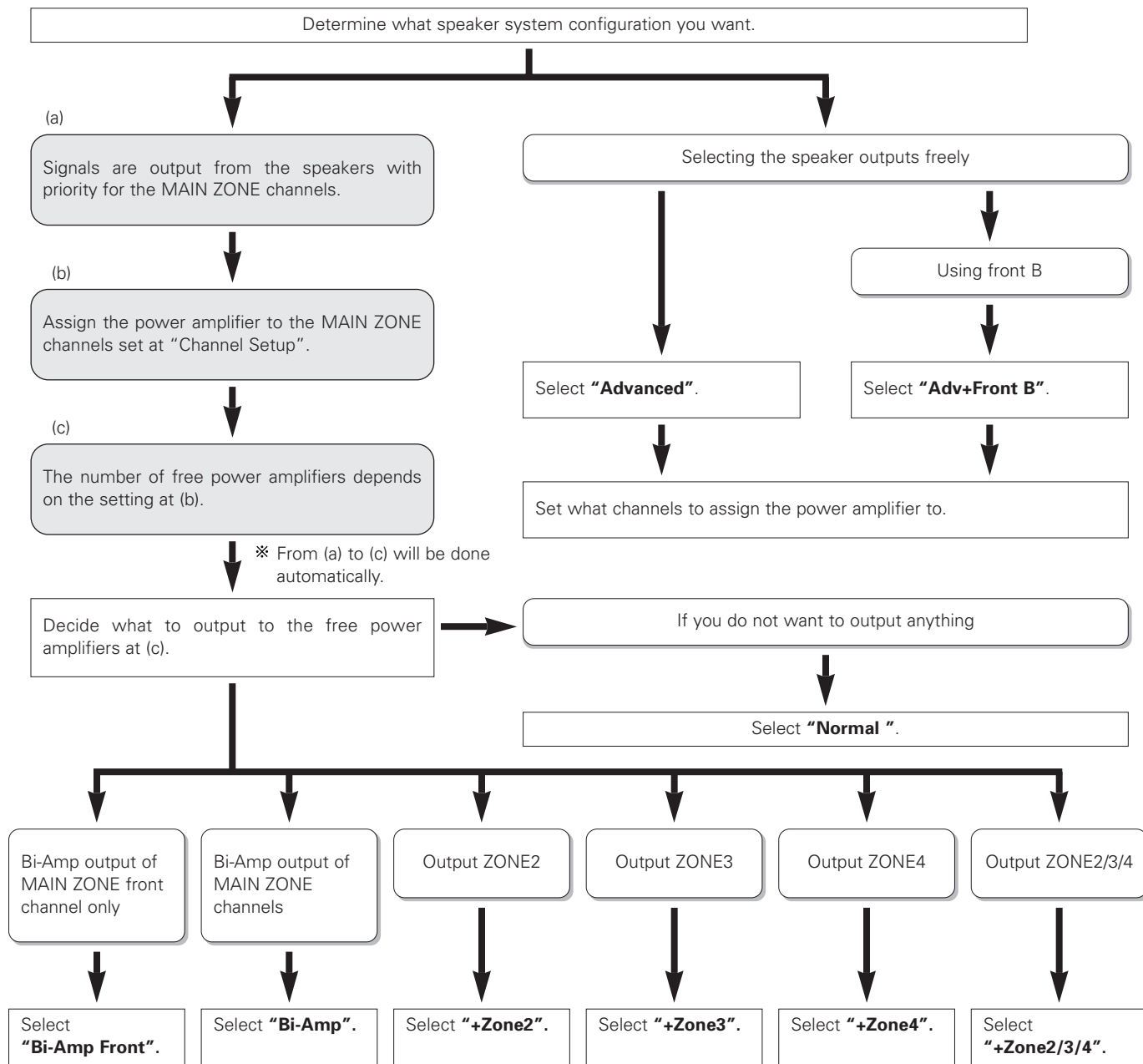

Advanced Setup – Part 1

1 Press the **CURSOR** Δ or ∇ button to select “Power Amp Assign” at the “Option Setup” menu, then press the **ENTER** button.

- The “Power Amp Assign” screen appears.

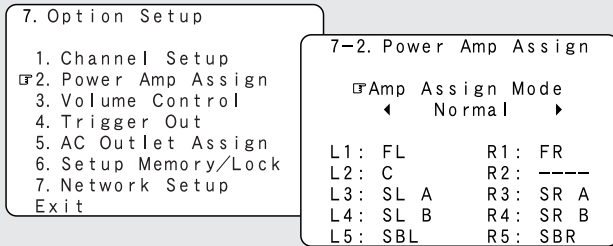

2 Press the **CURSOR** \triangleleft or \triangleright button to select the Amp Assign mode according to the speaker system you want to achieve.

Normal:

This is the recommended amplifier assignment mode. Normally select this when not conducting the power amplifier assignment.

By default, this is set to “Normal”.

Advanced:

With this mode, the power amplifiers can be assigned freely to the desired channels according to the speaker system you are using.

Adv+Front B:

With this mode, the power amplifiers can be assigned freely to the desired channels and front B.

- ※ The following modes can be selected when there are power amplifiers that are free with respect to the recommended amplifier assignment mode (“Normal”).

+Zone2:

This mode is the setting of the status in which the power amplifier is assigned to the ZONE2 output channel.

+Zone3:

This mode is the setting of the status in which the power amplifier is assigned to the ZONE3 output channel.

+Zone4:

This mode is the setting of the status in which the power amplifier is assigned to the ZONE4 output channel.

+Zone2/3:

This mode is the setting of the status in which the power amplifier is assigned simultaneously to the ZONE2 and 3 output channels.

+Zone3/4:

This mode is the setting of the status in which the power amplifier is assigned simultaneously to the ZONE3 and 4 output channels.

+Zone2/4:

This mode is the setting of the status in which the power amplifier is assigned simultaneously to the ZONE2 and 4 output channels.

+Zone2/3/4:

This mode is the setting of the status in which the power amplifier is assigned simultaneously to the ZONE2, 3 and 4 output channels.

Bi-Amp+Front:

This mode is the setting for playing the front channel with bi-amp connections.

Bi-Amp:

This mode is the setting for playing the front, center and surround channels with bi-amp connections.

- ※ When “Advanced” or “Adv+Front B” is selected, the power amplifiers can be assigned freely to the desired channels.

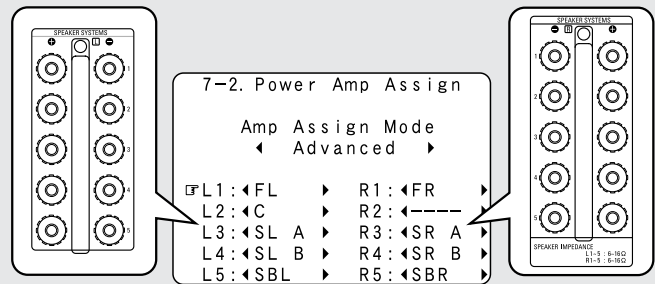

3 When “Advanced” or “Adv+Front B” is selected:

Press the **CURSOR** Δ or ∇ button to select the power amplifier to be assigned, then press the **CURSOR** \triangleleft or \triangleright button to select which channel to assigned the amplifier to.

4 Press the **ENTER** button to enter the setting.

- The “Option Setup” menu reappears.



- The amplifier assignment modes that can be selected differ according to the channel settings made at “Channel Setup” (👉 page 126 ~ 128).
- The status in which power amplifiers are assigned to output channels in the different amplifier assignment modes differs according to the channel settings for the different zones (👉 page 131, 132).
- If the “Advanced” or “Adv+Front B” amplifier assignment mode is selected, the channels to which power amplifiers can be assigned differ according to the channel settings for the different zones (👉 page 133).

Bi-Amp connections

Certain loudspeakers are equipped with two sets of input terminals, for bi-amplification. The AVR-5805CI Amp Assign mode allows you to power bi-amp-capable speakers with two amplifier channels, up to a total of 5 bi-amplified speakers in a system using all 10 of the AVR-5805CI amplifier channels. Be sure to consult the operating instructions of your bi-amp-capable speakers for further information before proceeding.

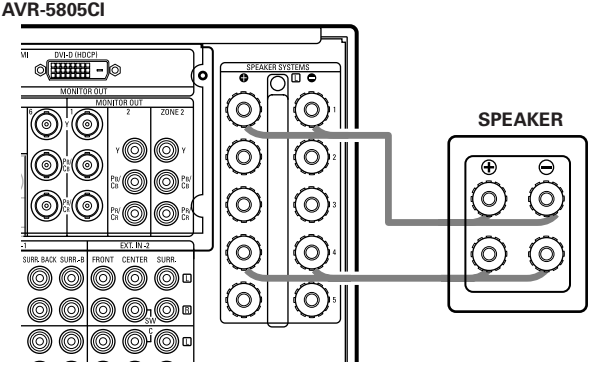

NOTE:

- When making bi-amp connections, be sure to remove the short-circuiting bar included with the speaker.

■ **Table of power amplifier assignment modes with respect to the channel settings for the different zones and assignment modes**

- Amp Assign mode: Normal

Channel Setup →	MAIN ZONE	9.1 CH				7.1 CH				5.1 CH			
Power Amp Assign	L1	FL	R1	FR	L1	FL	R1	FR	L1	FL	R1	FR	
	L2	C	R2	–	L2	C	R2	–	L2	C	R2	–	
	L3	SL A	R3	SR A	L3	SL A	R3	SR A	L3	SL A	R3	SR A	
	L4	SL B	R4	SR B	L4	–	R4	–	L4	–	R4	–	
	L5	SBL	R5	SBR	L5	SBL	R5	SBR	L5	–	R5	–	

- Amp Assign mode: +ZONE2

Channel Setup →	MAIN ZONE	9.1 CH				7.1 CH				5.1 CH																		
	ZONE2	MONO				STEREO				MONO				5.1 CH				STEREO				MONO						
Power Amp Assign	L1	FL	R1	FR	L1	FL	R1	FR	L1	FL	R1	FR	L1	FL	R1	FR	L1	FL	R1	FR	L1	FL	R1	FR	L1	FL	R1	FR
	L2	C	R2	Z2 M	L2	C	R2	–	L2	C	R2	Z2 M	L2	C	R2	Z2 C	L2	C	R2	–	L2	C	R2	–	L2	C	R2	Z2 M
	L3	SL A	R3	SR A	L3	SL A	R3	SR A	L3	SL A	R3	SR A	L3	SL A	R3	SR A	L3	SL A	R3	SR A	L3	SL A	R3	SR A	L3	SL A	R3	SR A
	L4	SL B	R4	SR B	L4	Z2 L	R4	Z2 R	L4	–	R4	–	L4	Z2 FL	R4	Z2 FR	L4	Z2 L	R4	Z2 R	L4	–	R4	–	L4	–	R4	–
	L5	SBL	R5	SBR	L5	SBL	R5	SBR	L5	SBL	R5	SBR	L5	Z2 SL	R5	Z2 SR	L5	–	R5	–	L5	–	R5	–	L5	–	R5	–

- Amp Assign mode: +ZONE3

Channel Setup →	MAIN ZONE	9.1 CH				7.1 CH				5.1 CH																		
	ZONE3	MONO				STEREO				MONO				STEREO				MONO										
Power Amp Assign	L1	FL	R1	FR	L1	FL	R1	FR	L1	FL	R1	FR	L1	FL	R1	FR	L1	FL	R1	FR	L1	FL	R1	FR	L1	FL	R1	FR
	L2	C	R2	Z3 M	L2	C	R2	–	L2	C	R2	Z3 M	L2	C	R2	–	L2	C	R2	–	L2	C	R2	Z3 M	L2	C	R2	Z3 M
	L3	SL A	R3	SR A	L3	SL A	R3	SR A	L3	SL A	R3	SR A	L3	SL A	R3	SR A	L3	SL A	R3	SR A	L3	SL A	R3	SR A	L3	SL A	R3	SR A
	L4	SL B	R4	SR B	L4	Z3 L	R4	Z3 R	L4	–	R4	–	L4	Z3 L	R4	Z3 R	L4	–	R4	–	L4	–	R4	–	L4	–	R4	–
	L5	SBL	R5	SBR	L5	SBL	R5	SBR	L5	SBL	R5	SBR	L5	–	R5	–	L5	–	R5	–	L5	–	R5	–	L5	–	R5	–

- Amp Assign mode: +ZONE4

Channel Setup →	MAIN ZONE	9.1 CH				7.1 CH				5.1 CH																		
	ZONE4	MONO				STEREO				MONO				STEREO				MONO										
Power Amp Assign	L1	FL	R1	FR	L1	FL	R1	FR	L1	FL	R1	FR	L1	FL	R1	FR	L1	FL	R1	FR	L1	FL	R1	FR	L1	FL	R1	FR
	L2	C	R2	Z4 M	L2	C	R2	–	L2	C	R2	Z4 M	L2	C	R2	–	L2	C	R2	–	L2	C	R2	Z4 M	L2	C	R2	Z4 M
	L3	SL A	R3	SR A	L3	SL A	R3	SR A	L3	SL A	R3	SR A	L3	SL A	R3	SR A	L3	SL A	R3	SR A	L3	SL A	R3	SR A	L3	SL A	R3	SR A
	L4	SL B	R4	SR B	L4	Z4 L	R4	Z4 R	L4	–	R4	–	L4	Z4 L	R4	Z4 R	L4	–	R4	–	L4	–	R4	–	L4	–	R4	–
	L5	SBL	R5	SBR	L5	SBL	R5	SBR	L5	SBL	R5	SBR	L5	–	R5	–	L5	–	R5	–	L5	–	R5	–	L5	–	R5	–



Advanced Setup – Part 1

- Amp Assign mode: +ZONE2/3

Channel Setup →	MAIN ZONE	7.1 CH												5.1 CH																										
	ZONE2	STEREO				MONO				MONO				STEREO				STEREO				MONO				MONO														
	ZONE3	MONO				STEREO				MONO				STEREO				MONO				STEREO				MONO														
Power Amp Assign	L1	FL	R1	FR	L1	FL	R1	FR	L1	FL	R1	FR	L1	FL	R1	FR	L1	FL	R1	FR	L1	FL	R1	FR	L1	FL	R1	FR	L1	FL	R1	FR	L1	FL	R1	FR	L1	FL	R1	FR
	L2	C	R2	Z3 M	L2	C	R2	Z2 M	L2	C	R2	Z3 M	L2	C	R2	–	L2	C	R2	Z3 M	L2	C	R2	Z2 M	L2	C	R2	Z3 M	L2	C	R2	Z2 M	L2	C	R2	Z3 M				
	L3	SL A	R3	SR A	L3	SL A	R3	SR A	L3	SL A	R3	SR A	L3	SL A	R3	SR A	L3	SL A	R3	SR A	L3	SL A	R3	SR A	L3	SL A	R3	SR A	L3	SL A	R3	SR A	L3	SL A	R3	SR A				
	L4	Z2 L	R4	Z2 R	L4	Z3 L	R4	Z3 R	L4	Z2 M	R4	–	L4	Z2 L	R4	Z2 R	L4	Z2 L	R4	Z2 R	L4	Z3 L	R4	Z3 R	L4	Z3 L	R4	Z3 R	L4	Z2 M	R4	–	L4	Z2 L	R4	Z2 R				
	L5	SBL	R5	SBR	L5	SBL	R5	SBR	L5	SBL	R5	SBR	L5	Z3 L	R5	Z3 R	L5	–	R5	–	L5	–	R5	–	L5	–	R5	–	L5	–	R5	–	L5	–	R5	–				

- Amp Assign mode: +ZONE3/4

Channel Setup →	MAIN ZONE	7.1 CH												5.1 CH																						
	ZONE3	STEREO				MONO				MONO				STEREO				STEREO				MONO				MONO										
	ZONE4	MONO				STEREO				MONO				STEREO				MONO				STEREO				MONO										
Power Amp Assign	L1	FL	R1	FR	L1	FL	R1	FR	L1	FL	R1	FR	L1	FL	R1	FR	L1	FL	R1	FR	L1	FL	R1	FR	L1	FL	R1	FR	L1	FL	R1	FR	L1	FL	R1	FR
	L2	C	R2	Z4 M	L2	C	R2	Z3 M	L2	C	R2	Z4 M	L2	C	R2	–	L2	C	R2	Z4 M	L2	C	R2	Z3 M	L2	C	R2	Z4 M	L2	C	R2	Z3 M	L2	C	R2	Z4 M
	L3	SL A	R3	SR A	L3	SL A	R3	SR A	L3	SL A	R3	SR A	L3	SL A	R3	SR A	L3	SL A	R3	SR A	L3	SL A	R3	SR A	L3	SL A	R3	SR A	L3	SL A	R3	SR A	L3	SL A	R3	SR A
	L4	Z3 L	R4	Z3 R	L4	Z4 L	R4	Z4 R	L4	Z3 M	R4	–	L4	Z3 L	R4	Z3 R	L4	Z3 L	R4	Z3 R	L4	Z4 L	R4	Z4 R	L4	Z4 L	R4	Z4 R	L4	Z3 M	R4	–	L4	Z3 L	R4	Z3 R
	L5	SBL	R5	SBR	L5	SBL	R5	SBR	L5	SBL	R5	SBR	L5	Z4 L	R5	Z4 R	L5	–	R5	–	L5	–	R5	–	L5	–	R5	–	L5	–	R5	–	L5	–	R5	–

- Amp Assign mode: +ZONE2/4

Channel Setup →	MAIN ZONE	7.1 CH												5.1 CH																						
	ZONE2	STEREO				MONO				MONO				STEREO				STEREO				MONO				MONO										
	ZONE4	MONO				STEREO				MONO				STEREO				MONO				STEREO				MONO										
Power Amp Assign	L1	FL	R1	FR	L1	FL	R1	FR	L1	FL	R1	FR	L1	FL	R1	FR	L1	FL	R1	FR	L1	FL	R1	FR	L1	FL	R1	FR	L1	FL	R1	FR	L1	FL	R1	FR
	L2	C	R2	Z4 M	L2	C	R2	Z2 M	L2	C	R2	Z4 M	L2	C	R2	–	L2	C	R2	Z4 M	L2	C	R2	Z2 M	L2	C	R2	Z4 M	L2	C	R2	Z2 M	L2	C	R2	Z4 M
	L3	SL A	R3	SR A	L3	SL A	R3	SR A	L3	SL A	R3	SR A	L3	SL A	R3	SR A	L3	SL A	R3	SR A	L3	SL A	R3	SR A	L3	SL A	R3	SR A	L3	SL A	R3	SR A	L3	SL A	R3	SR A
	L4	Z2 L	R4	Z2 R	L4	Z4 L	R4	Z4 R	L4	Z2 M	R4	–	L4	Z2 L	R4	Z2 R	L4	Z2 L	R4	Z2 R	L4	Z4 L	R4	Z4 R	L4	Z4 L	R4	Z4 R	L4	Z2 M	R4	–	L4	Z2 L	R4	Z2 R
	L5	SBL	R5	SBR	L5	SBL	R5	SBR	L5	SBL	R5	SBR	L5	Z4 L	R5	Z4 R	L5	–	R5	–	L5	–	R5	–	L5	–	R5	–	L5	–	R5	–	L5	–	R5	–

- Amp Assign mode: +ZONE2/3/4

Channel Setup →	MAIN ZONE	7.1 CH												5.1 CH																						
	ZONE2	MONO				STEREO				STEREO				MONO				STEREO				MONO				MONO										
	ZONE3	MONO				STEREO				MONO				STEREO				MONO				STEREO				MONO										
	ZONE4	MONO				MONO				STEREO				STEREO				MONO				MONO				STEREO				MONO						
Power Amp Assign	L1	FL	R1	FR	L1	FL	R1	FR	L1	FL	R1	FR	L1	FL	R1	FR	L1	FL	R1	FR	L1	FL	R1	FR	L1	FL	R1	FR	L1	FL	R1	FR	L1	FL	R1	FR
	L2	C	R2	Z2 M	L2	C	R2	Z4 M	L2	C	R2	Z3 M	L2	C	R2	Z2 M	L2	C	R2	Z3 M	L2	C	R2	Z2 M	L2	C	R2	Z4 M	L2	C	R2	Z2 M	L2	C	R2	Z2 M
	L3	SL A	R3	SR A	L3	SL A	R3	SR A	L3	SL A	R3	SR A	L3	SL A	R3	SR A	L3	SL A	R3	SR A	L3	SL A	R3	SR A	L3	SL A	R3	SR A	L3	SL A	R3	SR A	L3	SL A	R3	SR A
	L4	Z3 M	R4	Z4 M	L4	Z2 L	R4	Z2 R	L4	Z2 L	R4	Z2 R	L4	Z3 L	R4	Z3 R	L4	Z2 L	R4	Z2 R	L4	Z3 L	R4	Z3 R	L4	Z3 L	R4	Z3 R	L4	Z4 L	R4	Z4 R	L4	Z3 M	R4	Z4 M
	L5	SBL	R5	SBR	L5	Z3 L	R5	Z3 R	L5	Z4 L	R5	Z4 R	L5	Z4 L	R5	Z4 R	L5	Z4 M	R5	–	L5	Z4 M	R5	–	L5	Z3 M	R5	–	L5	–	R5	–	L5	–	R5	–

- Amp Assign mode: Bi-Amp Front

Channel Setup →	MAIN ZONE	7.1 CH				5.1 CH			
Power Amp Assign	L1	FL	R1	FR	L1	FL	R1	FR	
	L2	C	R2	–	L2	C	R2	–	
	L3	SL A	R3	SR A	L3	SL A	R3	SR A	
	L4	FL	R4	FR	L4	FL	R4	FR	
	L5	SBL	R5	SBR	L5	–	R5	–	

- Amp Assign mode: Bi-Amp

Channel Setup →	MAIN ZONE	5.1 CH			
Power Amp Assign	L1	FL	R1	FR	
	L2	C	R2	C	
	L3	SL A	R3	SR A	
	L4	FL	R4	FR	
	L5	SL A	R5	SR A	

■ **Table of channels to which power amplifiers can be assigned with respect to the channel settings for the different zones and the amplifier assignment modes**

- Amp Assign mode: Advanced

Channel Setup ↓		ASSIGNABLE CHANNEL
MAIN ZONE	ZONE2	
9.1 CH	5.1CH	FL, FR, C, SL A, SR A, SL B, SR B, SBL, SBR, Z2 FL, Z2 FR, Z2 C, Z2 SL, Z2 SR, Z3 L, Z3 R, Z4 L, Z4 R
	STEREO	FL, FR, C, SL A, SR A, SL B, SR B, SBL, SBR, Z2 L, Z2 R, Z3 L, Z3 R, Z4 L, Z4 R
	MONO	FL, FR, C, SL A, SR A, SL B, SR B, SBL, SBR, Z2 M, Z3 L, Z3 R, Z4 L, Z4 R
7.1 CH	7.1CH	FL, FR, C, SL A, SR A, SBL, SBR, Z2 FL, Z2 FR, Z2 C, Z2 SL, Z2 SR, Z2 SBL, Z2 SBR, Z3 L, Z3 R, Z4 L, Z4 R
	5.1CH	FL, FR, C, SL A, SR A, SBL, SBR, Z2 FL, Z2 FR, Z2 C, Z2 SL, Z2 SR, Z3 L, Z3 R, Z4 L, Z4 R
	STEREO	FL, FR, C, SL A, SR A, SBL, SBR, Z2 L, Z2 R, Z3 L, Z3 R, Z4 L, Z4 R
	MONO	FL, FR, C, SL A, SR A, SBL, SBR, Z2 M, Z3 L, Z3 R, Z4 L, Z4 R
5.1 CH	7.1CH	FL, FR, C, SL A, SR A, Z2 FL, Z2 FR, Z2 C, Z2 SL, Z2 SR, Z2 SBL, Z2 SBR, Z3 L, Z3 R, Z4 L, Z4 R
	5.1CH	FL, FR, C, SL A, SR A, Z2 FL, Z2 FR, Z2 C, Z2 SL, Z2 SR, Z3 L, Z3 R, Z4 L, Z4 R
	STEREO	FL, FR, C, SL A, SR A, Z2 L, Z2 R, Z3 L, Z3 R, Z4 L, Z4 R
	MONO	FL, FR, C, SL A, SR A, Z2 M, Z3 L, Z3 R, Z4 L, Z4 R

- Amp Assign mode: Adv+Front B

Channel Setup ↓		ASSIGNABLE CHANNEL
MAIN ZONE	ZONE2	
9.1 CH	5.1CH	FL A, FR A, FL B, FR B, C, SL A, SR A, SL B, SR B, SBL, SBR, Z2 FL, Z2 FR, Z2 C, Z2 SL, Z2 SR, Z3 L, Z3 R, Z4 L, Z4 R
	STEREO	FL A, FR A, FL B, FR B, C, SL A, SR A, SL B, SR B, SBL, SBR, Z2 L, Z2 R, Z3 L, Z3 R, Z4 L, Z4 R
	MONO	FL A, FR A, FL B, FR B, C, SL A, SR A, SL B, SR B, SBL, SBR, Z2 M, Z3 L, Z3 R, Z4 L, Z4 R
7.1 CH	7.1CH	FL A, FR A, FL B, FR B, C, SL A, SR A, SBL, SBR, Z2 FL, Z2 FR, Z2 C, Z2 SL, Z2 SR, Z2 SBL, Z2 SBR, Z3 L, Z3 R, Z4 L, Z4 R
	5.1CH	FL A, FR A, FL B, FR B, C, SL A, SR A, SBL, SBR, Z2 FL, Z2 FR, Z2 C, Z2 SL, Z2 SR, Z3 L, Z3 R, Z4 L, Z4 R
	STEREO	FL A, FR A, FL B, FR B, C, SL A, SR A, SBL, SBR, Z2 L, Z2 R, Z3 L, Z3 R, Z4 L, Z4 R
	MONO	FL A, FR A, FL B, FR B, C, SL A, SR A, SBL, SBR, Z2 M, Z3 L, Z3 R, Z4 L, Z4 R
5.1 CH	7.1CH	FL A, FR A, FL B, FR B, C, SL A, SR A, Z2 FL, Z2 FR, Z2 C, Z2 SL, Z2 SR, Z2 SBL, Z2 SBR, Z3 L, Z3 R, Z4 L, Z4 R
	5.1CH	FL A, FR A, FL B, FR B, C, SL A, SR A, Z2 FL, Z2 FR, Z2 C, Z2 SL, Z2 SR, Z3 L, Z3 R, Z4 L, Z4 R
	STEREO	FL A, FR A, FL B, FR B, C, SL A, SR A, Z2 L, Z2 R, Z3 L, Z3 R, Z4 L, Z4 R
	MONO	FL A, FR A, FL B, FR B, C, SL A, SR A, Z2 M, Z3 L, Z3 R, Z4 L, Z4 R

※ The above is an example of the selectable channels when “STEREO” is set for the ZONE3 and 4 channel setting. If “MONO” is selected, “Z3 M” and “Z4 M” are displayed.



Advanced Setup – Part 1

Setting the Volume Control

- Set the upper limit for the volume, the volume level when the power is turned on, and the volume level when the mute mode is set for the each zones.

1 Press the **CURSOR** Δ or ∇ button to select “Volume Control” at the “Option Setup” menu, then press the **ENTER** button.

- The “Volume Control” screen appears.

```
7. Option Setup
1. Channel Setup
2. Power Amp Assign
3. Volume Control
4. Trigger Out
5. AC Outlet Assign
6. Setup Memory/Lock
7. Network Setup
Exit
```

```
7-3. Volume Control
Main Vol. Limit ◀ OFF
P. On Lev. LAS
Mute Lev. ◀ FULL
Zone2 Vol. Lev. ◀ VAR
Vol. Limit ◀ OFF
P. On Lev. LAS
Mute Lev. ◀ FULL
7-3. Volume Control
Zone3 Vol. Lev. ◀ VAR
Vol. Limit ◀ OFF
P. On Lev. LAST
Mute Lev. ◀ FULL
Zone4 Vol. Lev. ◀ VAR
Vol. Limit ◀ OFF
P. On Lev. LAST
Mute Lev. ◀ FULL
```

2 Press the **CURSOR** Δ or ∇ button to select the desired setting, then press the **CURSOR** \triangleleft or \triangleright button to select the parameter.

Volume Limit:

Set the upper limit for the volume for the different zones.

- **-20 dB, -10 dB, 0 dB:**
The volume cannot be increased above the selected levels.
- **OFF:**
If you do not want to set a volume limit, select “OFF”.
In this case, the volume can be set to the AVR-5805CI’s maximum volume (output) level of +18 dB, which is extremely loud.

Power On Level:

Set the volume that is set when the power is turned on for the different zones.

You can adjust the volume level within the range of -80 to +18 dB in steps of 1.0 dB.

- **---** (Mute)
The volume is always muted when the power is turned on.
- **LAST**
The volume set when the AVR-5805CI was last used is stored in the memory and set when the power is turned on.

Mute Level:

Set the volume attenuation level when the mute mode is set for the different zones.

- **FULL**
The volume is fully muted.
- **-40 dB**
The volume is lowered 40 dB from the current level.
- **-20 dB**
The volume is lowered 20 dB from the current level.

Volume Level:

Set whether to fix the output level for the different zones or make it variable.

- **VAR** (variable)
The level can be adjusted freely using buttons on the remote control unit.
- **-40 dB, 0 dB**
The output level is fixed at the set level and the volume can no longer be adjusted.

3 Press the **ENTER** button to enter the setting.

- The “Option Setup” menu reappears.



- For ZONE2, ZONE3 and ZONE4 the “Volume Limit” and “Power On Level” can be set when “Variable” is selected for “Volume Level”.
- When the power amplifier is assigned to either of the ZONE2, ZONE3 and ZONE4 channels at “Power Amp Assign”, “-VAR-” (only variable) is displayed and the fixed level cannot be set.

Setting the Trigger Out

- Four 12 V DC Trigger Outputs on the rear panel can be used to control other devices with compatible trigger inputs, such as motorized screens, motorized screen masking, motorized drapes, and other trigger-controlled devices.
- Set the DC output supplied from the trigger out jacks for the various input sources to “ON” or “OFF”.

1 Press the **CURSOR** Δ or ∇ button to select “Trigger Out” at the “Option Setup” menu, then press the **ENTER** button.

- The “Trigger Out” screen appears.

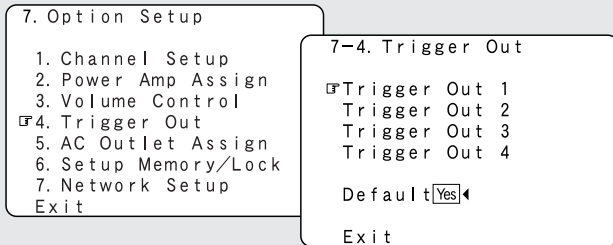

2 Press the **CURSOR** Δ or ∇ button to select the trigger out terminal you want to set, then press the **ENTER** button.

- Switch to the setting screen.

Example: When “Trigger Out 1” is selected

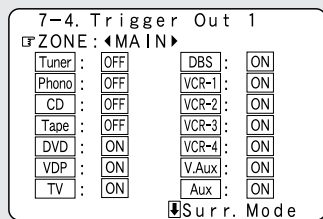

3 Press the **CURSOR** \leftarrow or \rightarrow button to select the zone (MAIN ZONE, ZONE2, ZONE3 and ZONE4).

- ※ The power supplied from the trigger out terminal turns on and off when the power for the set zone is turned on and off.

4 Press the **CURSOR** Δ or ∇ button to select the input source, then press the **CURSOR** \leftarrow or \rightarrow button to select “ON” or “OFF”.

ON:

When that input source is selected, the power supplied from the trigger out terminal turns on.

OFF:

When that input source is selected, the power supplied from the trigger out terminal turns off.

5 If “MAIN” was selected at step 3: Press the **CURSOR** Δ or ∇ button to select the surround mode, then press the **CURSOR** \leftarrow or \rightarrow button to select “ON” or “OFF”.

ON:

If “ON” is selected when an input source set to “ON” is selected, the power supplied from the trigger out terminal turns on.

OFF:

If “OFF” is selected when an input source set to “ON” is selected, the power supplied from the trigger out terminal turns off.

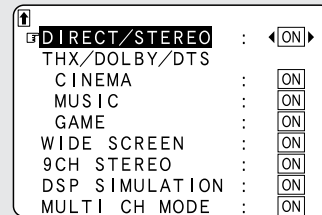

6 Press the **ENTER** button.

- The “Trigger Out” screen reappears.

- ※ Use the same procedure to make the settings for Trigger Out 2, 3, 4.

7 Press the **CURSOR** Δ or ∇ button to select “Exit”, then press the **ENTER** button.

- The “Option Setup” menu reappears.

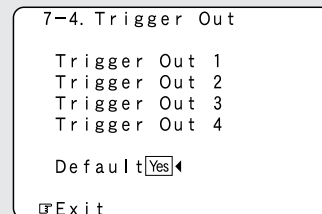

- ※ When “Default Yes” is selected, then press the **CURSOR** \leftarrow button to reset to the default values.

Advanced Setup – Part 1

Setting the AC Outlet Assignment

- This sets the AC outlet to on or off for the different input sources.

1 Press the **CURSOR** Δ or ∇ button to select “AC Outlet Assign” at the “Option Setup” menu, then press the **ENTER** button.

- The “AC Outlet Assign” screen appears.

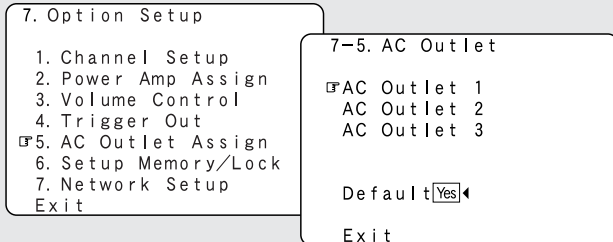

2 Press the **CURSOR** Δ or ∇ button to select the AC outlet you want to set, then press the **ENTER** button.

- Switch to the setting screen.

Example: When “AC Outlet 1” is selected

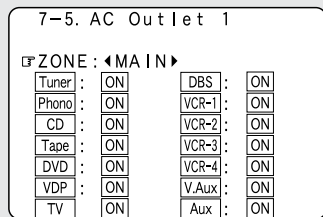

3 Press the **CURSOR** \leftarrow or \rightarrow button to select the zone (MAIN ZONE, ZONE2, ZONE3 and ZONE4).

- ※ The power of the AC outlet turns on and off when the power for the set zone is turned on and off.

4 Press the **CURSOR** Δ or ∇ button to select the input source, then press the **CURSOR** \leftarrow or \rightarrow button to select “ON” or “OFF”.

ON:

The power of the AC outlet turns on when that input source is selected.

OFF:

The power of the AC outlet turns off when that input source is selected.

5 Press the **ENTER** button.

- The “AC Outlet Assign” screen reappears.

- ※ Use the same procedure to make the settings for AC Outlet 2, 3.

6 Press the **CURSOR** Δ or ∇ button to select “Exit”, then press the **ENTER** button.

- The “Option Setup” menu reappears.

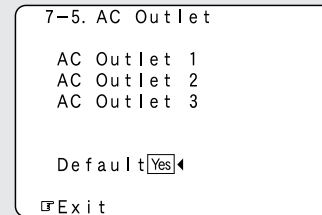

- ※ When “Default Yes” is selected, then press the **CURSOR** \leftarrow button to reset to the default values.

Memory backup and protecting the setting

■ **User Memory**

This stores the current user settings in the memory.

1 Press the **CURSOR** Δ or ∇ button to select “Setup Memory / Lock” at the “Option Setup” menu, then press the **ENTER** button.

- The “Setup Memory / Lock” screen appears.

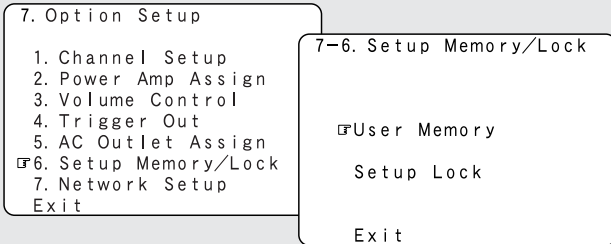

2 Press the **CURSOR** Δ or ∇ button to select “User Memory”, then press the **ENTER** button.

- Switch to the “User Memory” screen.

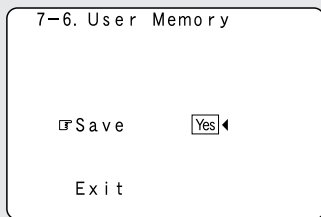

3 Press the **CURSOR** \triangleleft button to select “Save Yes”.

- About 30 seconds are required for the settings to be stored in the memory.

※ Once the settings are stored in the memory, “Load” is displayed and the settings can be loaded.

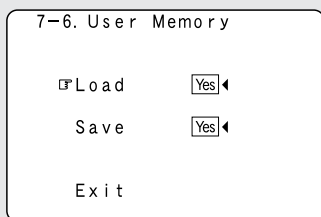

4 Press the **CURSOR** Δ or ∇ button to select “Exit”, then press the **ENTER** button.

- The “Setup Memory / Lock” screen reappears.

■ **Setup Lock**

This sets whether or not to lock the system setup settings so that they cannot be changed.

Once all the settings are made, set “Setup Lock” to “ON”.

1 Press the **CURSOR** Δ or ∇ button to select “Setup Lock” at the “Setup Memory / Lock” screen, then press the **ENTER** button.

- Switch to the “Setup Lock” screen.

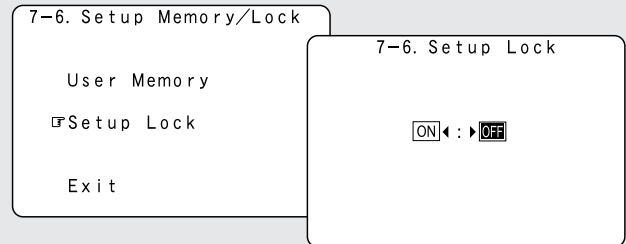

2 Press the **CURSOR** \triangleleft button to select “ON”, to lock the system setup settings, then press the **ENTER** button.



- When the setup lock function is activated, the settings listed below cannot be changed, and “SETUP LOCKED!” is displayed when related buttons are operated.

- System setup settings
- Surround parameter settings
- Tone control settings
- Channel level settings (including test tones)
- Room EQ

- To unlock, press the **SYSTEM SETUP** button again and display the “Setup Lock” screen, then select “OFF” and press the **ENTER** button.

Setting the Network Setup

- If you are using a broadband router (DHCP function), there is no need to make the settings at “Setting the IP Address” and “Setting the Proxy”, since the DHCP function is set to “ON” in the AVR-5805CI’s default settings.
- If the AVR-5805CI is being used connected to a network without the DHCP function, the network settings must be made. In this case, some knowledge of networks is required.

■ Setting the IP Address

Set this when “OFF” is set for “DHCP”.

1 Press the **CURSOR** Δ or ∇ button to select “Network Setup” at the “Option Setup” menu, then press the **ENTER** button.

- The “Network Setup” screen appears.

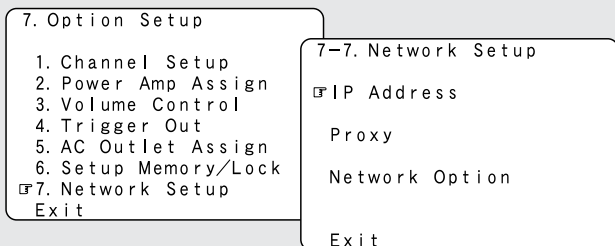

2 Press the **CURSOR** Δ or ∇ button to select “IP Address”, then press the **ENTER** button.

- The “IP Address” screen appears.

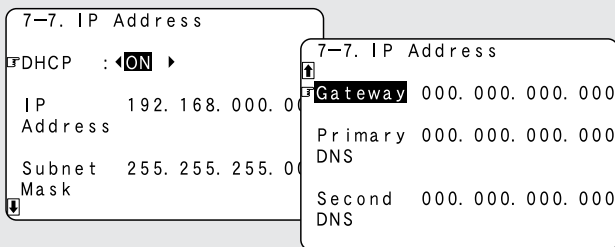

※ The IP address, etc., is not displayed when “DHCP” is set to “ON” and the unit is not connected to a network.

3 Press the **CURSOR** \triangleleft or \triangleright button to select “OFF”.

- The DHCP function is disabled.

4 Press the **CURSOR** Δ or ∇ button to select the desired setting item, then press the **CURSOR** \triangleright button and **CURSOR** Δ or ∇ button to input the address.

IP Address:

Set the IP address within the ranges shown below. The Network Audio function cannot be used if other IP addresses are set.

CLASS A: 10.0.0.0 ~ 10.255.255.255

CLASS B: 172.16.0.0 ~ 172.31.255.255

CLASS C: 192.168.0.0 ~ 192.168.255.255

Subnet Mask:

When connecting an xDSL modem or terminal adapter directly to the AVR-5805CI, input the subnet mask indicated in the documentation supplied by your provider. Normally input 255.255.255.0.

Gateway:

When connected to a gateway (router), input its IP address.

Primary DNS / Secondary DNS:

If there is only one DNS address indicated in the documentation supplied by your provider, input it at “Primary DNS”. If there are two or more DNS addresses, input the first one at “Second DNS”.

5 Press the **ENTER** button to enter the setting.

- The “Network Setup” menu reappears.



- DHCP (Dynamic Host Configuration Protocol): These are systems by which the IP address and other network settings are automatically set for the AVR-5805CI, computer, broadband router and network devices.
- DNS (Domain Name System): This is a system for converting the domain names used when browsing Internet sites (for example, “www.denon.jp”) into the IP addresses actually used for communications (for example, “202.221.192.106”).

■ **Setting the Proxy**

Make this setting when connecting to the Internet via a proxy server.

1 Press the **CURSOR** Δ or ∇ button to select “Proxy” at the “Network Setup” screen, then press the **ENTER** button.

- The “Proxy” screen appears.

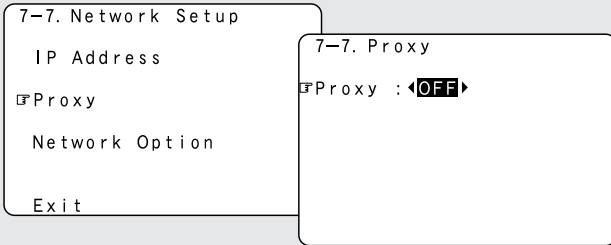

2 Press the **CURSOR** \leftarrow or \rightarrow button to select “ON”.

- The proxy server is enabled.

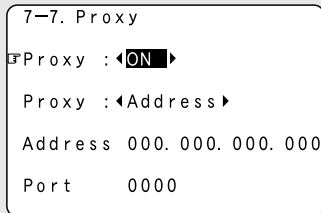

3 Press the **CURSOR** Δ or ∇ button to select the desired setting item, then press the **CURSOR** \rightarrow button and **CURSOR** Δ or ∇ button to input the character or number.

Proxy:

Input the proxy server domain name or address.

Port:

Input the proxy server port number.

4 Press the **ENTER** button to enter the setting.

- The “Network Setup” menu reappears.

■ **Setting the Network Option**

[1] Setting the Power Saving

When not using the AVR-5805CI connected in a network, set “ON” to reduce the power consumption when in the standby mode.

Set “OFF” when using the AVR-5805CI connected in a network.

1 Press the **CURSOR** Δ or ∇ button to select “Network Option” at the “Network Setup” screen, then press the **ENTER** button.

- The “Network Option” screen appears.

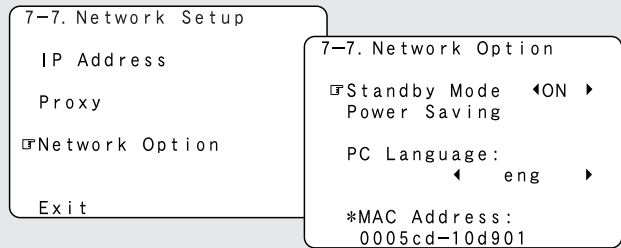

2 Press the **CURSOR** \leftarrow or \rightarrow button to select “ON” or “OFF”.

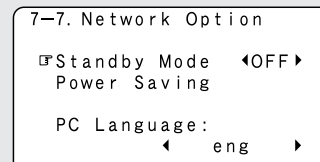

[2] Setting the PC Language

Select according to the language of the computer being used. The languages are indicated with three letters conforming to ISO639-2.

Press the **CURSOR** Δ or ∇ button to select “PC Language”, press the **CURSOR** \leftarrow or \rightarrow button to select PC language.

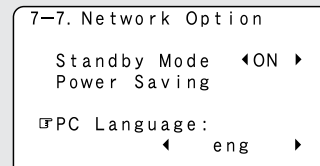

[3] Checking the MAC Address

- The AVR-5805CI’s MAC address is displayed.
- The MAC address differs for each set.

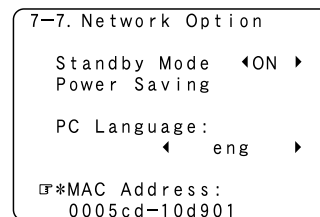

1 If the check ends, press the **ENTER** button.

- The “Network Setup” menu reappears.

2 Press the **CURSOR** Δ or ∇ button to select “Exit”, then press the **ENTER** button.

- The “Option Setup” menu reappears.

Advanced Setup – Part 2

- This Speaker Setup section describes the procedures to make speaker settings manually (without using the Auto Setup function), as well as to make manual changes to settings that have already been made by the Auto Setup function.

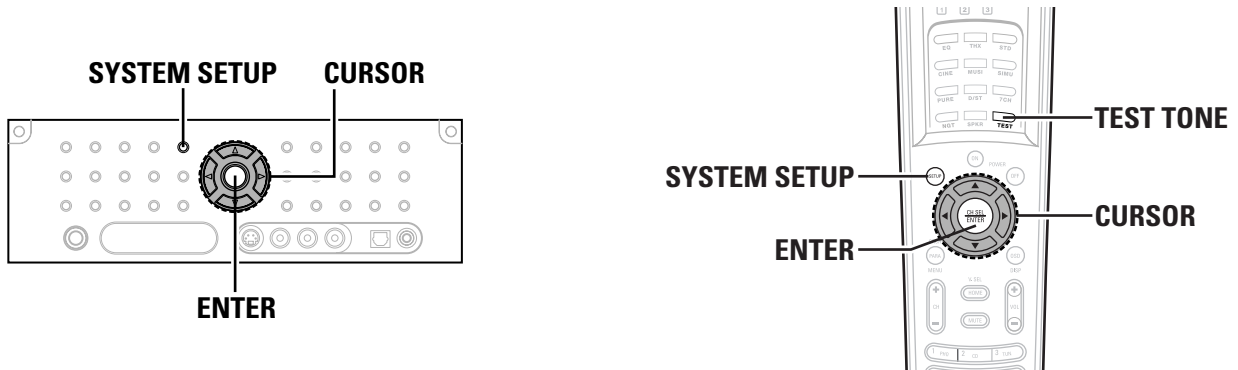

Speaker Setup

- If the “Auto Setup” procedure has already been performed, there is no need to make this setting.
- Perform this setting if you wish to make the settings for your speaker systems manually.

Setting the type of speakers

- The composition of the signals output to each channels and the frequency response are adjusted according to the combination of speakers actually being used.

- 1 Press the **CURSOR** Δ or ∇ button to select “Speaker Setup” at the “System Setup Menu”, then press the **ENTER** button.
 - The “Speaker Setup” menu appears.

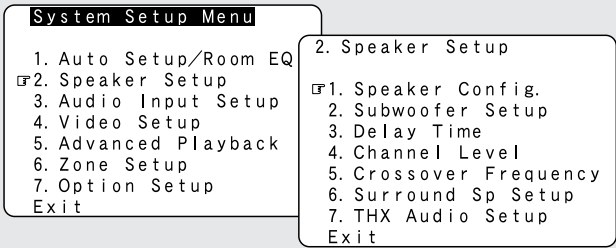

- 2 Press the **CURSOR** Δ or ∇ button to select “Speaker Config.”, then press the **ENTER** button.
 - The “Speaker Config.” screen appears.

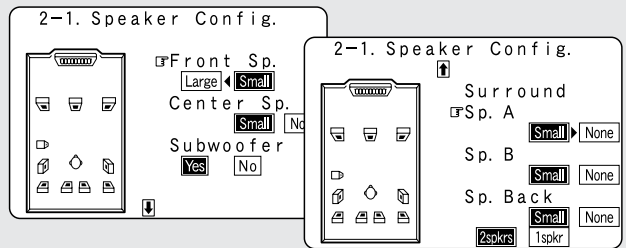

- 3 Press the **CURSOR** Δ or ∇ button to select the speaker, then press the **CURSOR** \triangleleft or \triangleright button to select the parameter.

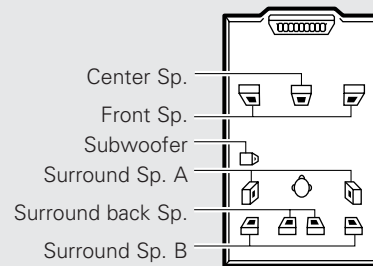

- 4 Press the **ENTER** button to enter the setting.
 - The “Speaker Setup” menu reappears.





- Select “Large” or “Small” not according to the actual size of the speaker but according to the speaker’s capacity for playing low frequency (bass sound below the frequency set for the Crossover Frequency) signals. If you do not know, try comparing the sound at both settings (setting the volume to a level low enough so as not to damage the speakers) to determine the proper setting.

Parameters

Large:

Select this when using speakers that can fully reproduce deep bass well below 80 Hz.

Small:

Select this when using speakers that are not capable of handling deep bass well below 80 Hz. Most home theater main and surround speakers perform best when configured as SMALL. Deep bass content in any channel with a SMALL speaker is routed to the subwoofer(s).

None:

Select this when no speakers are installed.

Yes / No:

Select “Yes” when a subwoofer is installed, “No” when a subwoofer is not installed.

2spkr / 1spkr:

Select the number of speakers to be used for the surround back channel.

- ※ A subwoofer with sufficient low frequency playback capability can better handle deep bass than most main and surround speakers, and the system’s overall performance will be greatly enhanced when SMALL is set for the main (front) and surround speakers.
- ※ To take full advantage of the performance of the Home THX certified speaker systems, set the front, center and surround speaker size parameters to “Small” and the subwoofer to “Yes”.
- ※ For the majority of speaker system configurations, using the SMALL setting for all main and surround speakers and connected subwoofer(s) set to ON will yield the best results.
- ※ When “Front” is set to “Small”, “Subwoofer” is automatically set to “Yes”, and when “Subwoofer” is set to “No”, “Front” is automatically set to “Large”.

Setting the low frequency distribution

- This selects the subwoofer for playing deep bass signals.

1 Press the CURSOR Δ or ∇ button to select “Subwoofer Setup” at the “Speaker Setup” menu, then press the ENTER button.

- The “Subwoofer Setup” screen appears.

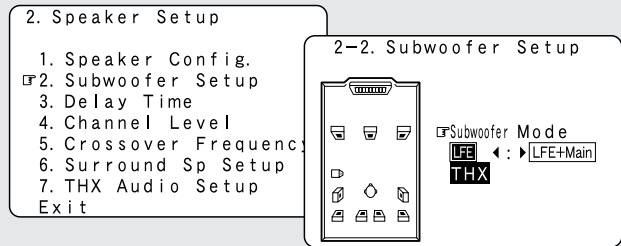

2 Press the CURSOR \triangleleft or \triangleright button to select the setting.

LFE-THX-:

For any channel(s) that are set to LARGE, low frequencies in that channel’s corresponding source are directed to that loudspeaker only. Low frequencies that are directed to the subwoofer(s) are from the program source LFE channel, and from other channels where the speakers are set to SMALL. THX recommends this mode so that bass interference is less likely to occur in the room.

LFE+Main:

Low frequencies from speaker channels that have been set to LARGE are reproduced from those speakers as well as from the subwoofer(s). Depending upon the characteristics of the LARGE main speakers, this mode may provide a more even low frequency response throughout the listening room.

3 Press the ENTER button to enter the setting.

- The “Speaker Setup” menu reappears.



Advanced Setup – Part 2



■ Assignment of low frequency signal range

- The only signals produced from the subwoofer channel are LFE signals (during playback of Dolby Digital or DTS signals) and the low frequency signal range of channels set to "Small" in the setup menu. The low frequency signal range of channels set to "Large" are produced from those channels.

■ Subwoofer Setup

- The subwoofer mode setting is only valid when and "Yes" is set for the subwoofer in the "Speaker Configuration" settings (page 140, 141).
- When the input signal is analog or a PCM signal not including LFE signals, if "LFE-THX-" is selected, the low frequency component is not output from the subwoofer. To output the subwoofer channel, select "LFE+Main".

Setting the Delay Time

- This parameter is for optimizing the timing with which the audio signals are produced from the speakers and subwoofer according to the listening position.
- Two surround back speakers are required to use the THX Ultra2 Cinema, THX Music mode and THX Games mode. Set the surround back speakers so that the distance to the listening position is the same for both the left and right speakers. It is also recommended that the deviations of the distance from the listening position to L and R channel speakers (front left (FL) and front right (FR), surround left (SL) and surround right (SR), surround back left (SBL) and surround back right (SBR)) is less than 2 ft (60 cm).

Preparations:

Measure the distances between the listening position and the speakers (L1 to L11 on the diagram at the below).

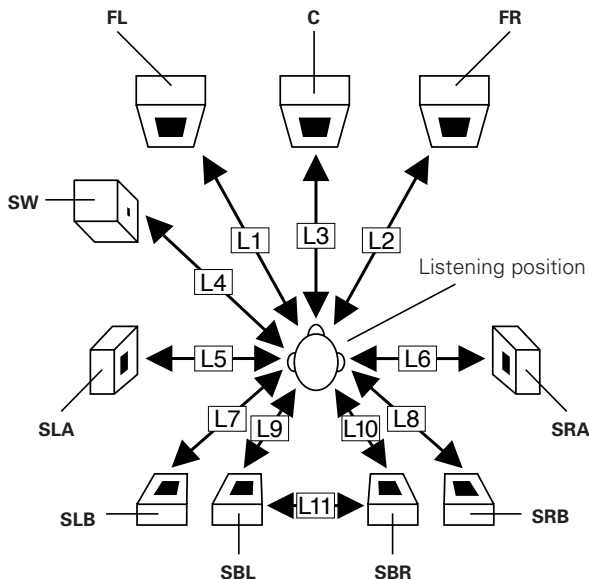

1 Press the CURSOR Δ or ∇ button to select "Delay Time" at the "Speaker Setup" menu, then press the ENTER button.

- The "Delay Time" screen appears.

2. Speaker Setup

1. Speaker Config.
2. Subwoofer Setup
3. Delay Time
4. Channel Level
5. Crossover Frequency
6. Surround Sp Setup
7. THX Audio Setup
- Exit

2-3. Delay Time

Set The Distance To Each Speakers

Do You Prefer In Meters? / In Feet?

Meters \leftarrow \rightarrow Feet

2 Press the CURSOR \leftarrow or \rightarrow button to select the desired unit, "Meters" or "Feet".

- The "Delay Time" screen appears automatically.

Example: When "Feet" is selected

2-3. Delay Time

Set The Distance To Each Speakers

Do You Prefer In Meters? / In Feet?

Meters \leftarrow \rightarrow **Feet**



2-3. Delay Time

Step \leftarrow 1ft \rightarrow
Default Yes \leftarrow

FL \leftarrow 12.0ft \rightarrow L1
FR 12.0ft L2
C 12.0ft L3
SW 12.0ft L4

2-3. Delay Time

SL A \leftarrow 10.0ft \rightarrow L5
SR A 10.0ft L6
SL B 10.0ft L7
SR B 10.0ft L8
SBL 10.0ft L9
SBR 10.0ft L10

3 Press the CURSOR Δ or ∇ button to select the speaker to be set.

4 Press the **CURSOR** ◀ or ▶ button to set the distance between the center speaker and listening position.

Example: When the distance is set to 10.0 feet for the center speaker

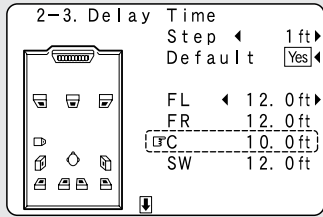

- ※ The distance changes in units of 1 foot or 0.1 foot each time the button is pressed. Select the value closest to the measured distance.
- ※ When "Step" is selected, you can select the unit of "1 ft (0.1 m)" or "0.1 ft (0.01 m)".
- ※ When "Default Yes" is selected, then press the **CURSOR** ◀ button to reset to the default values.
- ※ **The difference of the distances set for the various speakers must be 20.0 ft (6.0 m) or under. If an inappropriate distance is set, "RELOCATE BLINKING SP!" is displayed. In this case, move the relevant speaker to the proper position as indicated by the displayed value.**

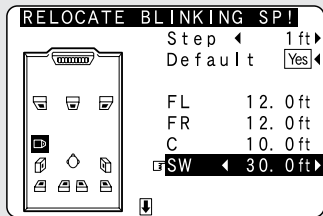

5 Press the **ENTER** button to enter the setting.

- The "Speaker Setup" menu reappears.

- ※ The AVR-5805CI automatically sets the optimum surround delay time for the listening room.

Setting the Channel Level

- Use this setting to adjust so that the playback level between the different channels is equal.
- From the listening position, listen to the test tones produced from the speakers to adjust the level.
- The level of each channel should be adjusted to 75 dB (C-weighted, slow meter mode) on a sound level meter at the listening position.

If a sound level meter is not available adjust the channels by ear so the sound levels are the same. Because adjusting the subwoofer level test tone by ear is difficult, use a well known music selection and adjust for natural balance.

1 Press the **CURSOR** ▲ or ▼ button to select "Channel Level" at the "Speaker Setup" menu, then press the **ENTER** button.

- The "Channel Level" screen appears.

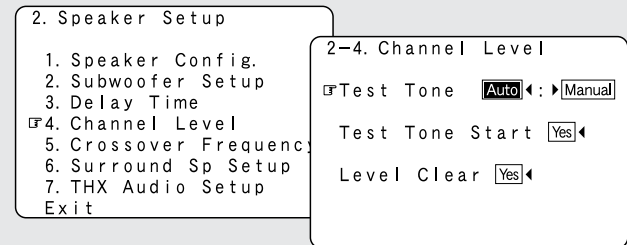

2 Press the **CURSOR** ◀ or ▶ button to select "Auto" or "Manual".

Auto:

Adjust the level while listening to the test tones produced automatically from each speaker.

Manual:

Select the speaker from which you want to produce the test tone to adjust the level.

Example: When the "Auto" mode is selected

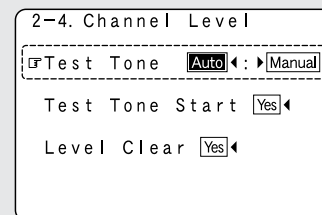

Advanced Setup – Part 2

- 3** Press the **CURSOR** \triangle or ∇ button to select “Test Tone Start”, then press the **CURSOR** \triangleleft button to select “Yes”.

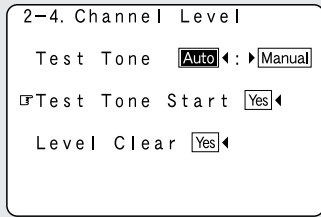

- 4** When “Auto” mode is selected:
-1 Press the **CURSOR** \triangleleft or \triangleright button to adjust all the speakers to the same volume.

- The test tones are emitted from each speaker in the following order, at 4 seconds intervals the first time and second time around, 2 seconds intervals the third time around and on:

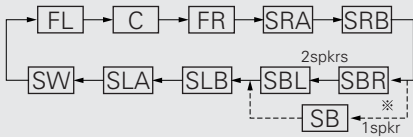

- ※ When the surround back speaker setting is set to “1spkr” for “Speaker Configuration”, this is set to “SB”.

Example: When the volume is set to -11.5 dB while the test tone is being produced from the Front L ch speaker

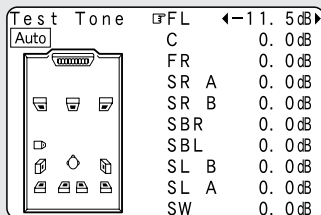

- ※ The volume can be adjusted between -12.0 dB and $+12.0$ dB in units of 0.5 dB.

- 4** When “Manual” mode is selected:
-2 Press the **CURSOR** \triangle or ∇ button to select the speaker, then press the **CURSOR** \triangleleft or \triangleright button to adjust all the speakers to the same volume.

Example: “Manual” mode is selected.

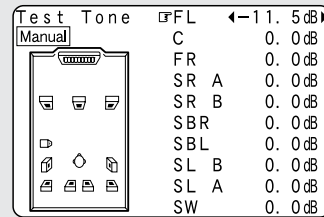

- 5** Press the **ENTER** button to enter the setting.
- The “Channel Level” screen reappears.



- To cancel the settings, press the **CURSOR** \triangleleft button to select “Level Clear” and “Yes” on the “Channel Level” screen, then make the settings again.

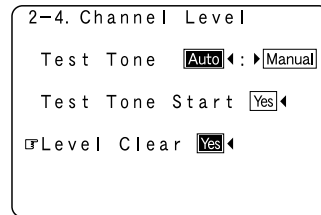

- When adjusting the level of an active subwoofer system, you may also need to adjust the subwoofer's own volume control.
- When you adjust the channel levels while in the SYSTEM SETUP CHANNEL LEVEL mode, the channel level adjustments made will affect all surround modes. Consider this mode a Master Channel Level adjustment mode.
- After you have completed the SYSTEM SETUP CHANNEL LEVEL adjustments, you can then activate the individual surround modes and adjust channel levels that will be remembered for each of those modes. Then, whenever you activate a particular surround sound mode, your preferred channel level adjustments for just that mode will be recalled. Check the instructions for adjusting channel levels within each surround mode (🔍 page 63, 64).
- You can adjust the channel levels for each of the following surround modes: PURE DIRECT/DIRECT, STEREO, STANDARD (DOLBY/DTS SURROUND), HOME THX CINEMA, 9CH STEREO, WIDE SCREEN, SUPER STADIUM, ROCK ARENA, JAZZ CLUB, CLASSIC CONCERT, MONO MOVIE, VIDEO GAME and MATRIX.
- When using either surround speakers A or B, or when using surround speakers A and B at the same time, be sure to adjust the balance of playback levels between each channel for the various selections of "A", "B" and "A + B".

■ **Adjusting the test tone using the remote control unit**

- As described below, this adjustment can be accomplished via the with remote control unit.
- Adjusting with the remote control unit using the test tones is only possible in the "Auto" mode and only effective in the STANDARD (DOLBY/DTS SURROUND) and HOME THX CINEMA modes. The adjusted levels for the different modes are automatically stored in the memory.

1 Press the TEST TONE button.

- Test tones are output from the different speakers.

2 Press the CURSOR ◀ or ▶ button to adjust the channel level so that the volume of the test tones is the same for all the speakers.

3 After completing the adjustment, press the TEST TONE button again.

Setting the Crossover Frequency

- Set the crossover frequency according to the low frequency response characteristics of the various (front, center, surround and surround back) speaker systems.
- If a connected main or surround loudspeaker has a specified -3 dB low frequency response rolloff, adjust the crossover frequency for that speaker to match the specified low frequency response limit – e.g. 80 Hz.
- When a speaker is set to SMALL, low frequencies in that channel that are below the crossover frequency are directed to the system's subwoofer(s), or to speakers that are set to LARGE, for systems with no connected subwoofer(s).

1 Press the CURSOR Δ or ▽ button to select "Crossover Frequency" at the "Speaker Setup" menu, then press the ENTER button.

- The "Crossover Frequency" screen appears.

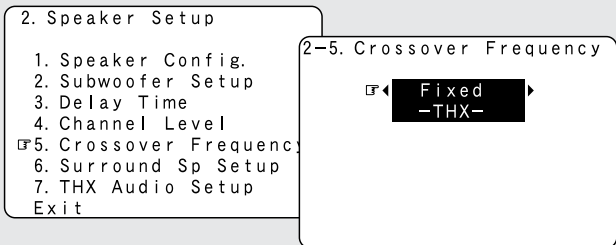

2 Press the CURSOR ◀ or ▶ button to select the frequency.

FIXED-THX-:

Set to the THX rated 80 Hz crossover frequency.

VARIABLE 40, 60, 80, 90, 100, 110, 120, 150, 200, 250 Hz:

Set as desired according to your speakers' bass playback ability.

Advanced

The crossover frequency can be set individually for the different speakers (🔍 page 146).

3 Press the ENTER button to enter the setting.

- The "Speaker Setup" menu reappears.



Advanced Setup – Part 2



- If "LFE+Main" is set at "Subwoofer Setup", "SW:LFE+Main" (👉 page 141, 142) is displayed at the top right of the screen.

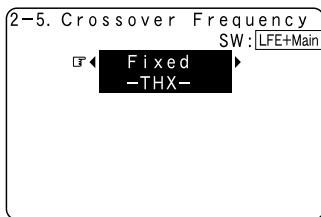

- Please set all THX Certified speakers to small and the crossover to 80 Hz.
- We recommend using with the crossover frequency set to "FIXED-THX-", but depending on the speaker, setting it to a different frequency may improve frequency response near the crossover frequency.
- The crossover frequency mode is valid only when subwoofer is set to "Yes", and when one or more speakers are set to SMALL, as described in section "Speaker Configuration" settings (👉 page 140, 141).

■ Setting the crossover frequency individually for the different channels

1 Press the **CURSOR** ◀ or ▶ button to select "Advanced" at the "Crossover Frequency" screen.

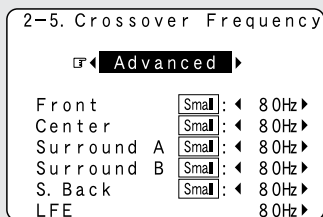

2 Press the **CURSOR** ▲ or ▼ button to select the speaker to be set.

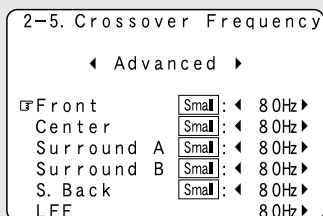

3 Press the **CURSOR** ◀ or ▶ button to select the frequency.

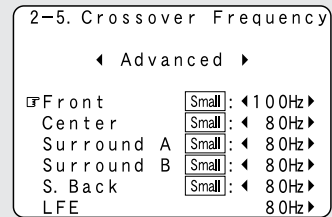

- "LFE-THX-" is selected at "Subwoofer Setup", the frequencies can only be selected for speakers set to "Small" at "Speaker Configuration".

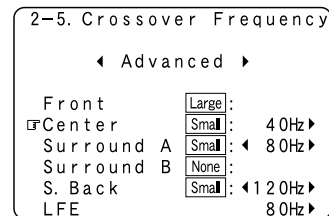

- If "LFE+Main" is set at "Subwoofer Setup", the frequencies can be selected regardless of the speaker size setting.

Selecting the Surround Speakers for the different surround modes

- Use this function when using multiple surround speaker combinations for more ideal surround sound.
- Once the combinations of surround speakers to be used for the different surround modes are preset, the surround speakers are selected automatically according to the surround mode.

1 Press the **CURSOR** ▲ or ▼ button to select "Surround Sp Setup" at the "Speaker Setup" menu, then press the **ENTER** button.

- The "Surround Sp Setup" screen appears.

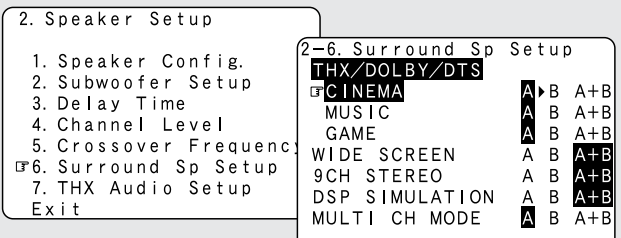

2 Press the **CURSOR** Δ or ∇ button to select the surround mode, then press the **CURSOR** \triangleleft or \triangleright button to select the surround speaker.

- A:**
When surround speakers A is used.
- B:**
When surround speakers B is used.
- A + B:**
When both surround speakers A and B are used.

3 Press the **ENTER** button to enter the setting.

- The "Speaker Setup" menu reappears.



- For the "WIDE SCREEN" and "9CH STEREO" DSP simulation modes, the surround speakers can be set separately.
- See page 105 for the selection of the surround speakers when the "ANALOG" mode is selected at "EXT. IN Setup".

Settings the THX Audio Setup

■ Settings for using a THX Ultra2 compatible subwoofer

- Make these settings when "Yes" is selected for the subwoofer in the "Speaker Configuration" settings. This option is not available when "No" is selected (see page 140, 141).

1 Press the **CURSOR** Δ or ∇ button to select "THX Audio Setup" at the "Speaker Setup" menu, then press the **ENTER** button.

- The "THX Audio Setup" screen appears.

2. Speaker Setup

1. Speaker Config.
2. Subwoofer Setup
3. Delay Time
4. Channel Level
5. Crossover Frequency
6. Surround Sp Setup
- \square 7. THX Audio Setup
- Exit

2-7. THX Audio Setup

\square Boundary Gain Compensation

Surround Back Speaker Position

Exit

2 Press the **CURSOR** Δ or ∇ button to select "Boundary Gain Compensation", then press the **ENTER** button.

3 Press the **CURSOR** \triangleleft or \triangleright button, when using a THX Ultra2 compatible subwoofer or subwoofer that frequency response extends to 20 Hz, select "Yes". Otherwise select "No".

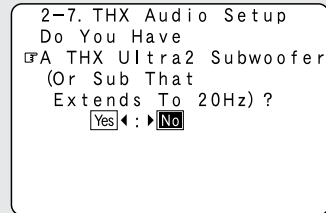

- ※ **When "Yes" is selected:**
"Boundary Gain Compensation" can be selected and the compensation set to "OFF".
- ※ **If the bass sound seems too strong:**
Set "Boundary Gain Compensation" to "ON". This activates a filter that gently reduces very deep bass below 55 Hz to provide the flattest overall deep bass response. Select "ON" or "OFF" according to how strong you prefer the deep bass response to be.

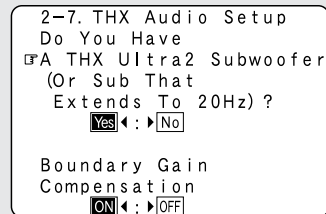

4 Press the **ENTER** button.

- The "THX Audio Setup" screen reappears.

Advanced Setup – Part 2

■ Surround Back Speaker Position Settings

- When two surround back speakers have been set in “Speaker Configuration” (page 140, 141), set the distance of the speakers. This option is not available when “1spkr” is selected.
- This setting is necessary to achieve the optimum effect in the THX Surround EX, THX Ultra2 Cinema, THX Music mode and THX Games mode. It is recommended that SBL/SBR speakers are placed together as close as possible.

1 Press the **CURSOR** Δ or ∇ button to select “Surround Back Speaker Position” at the “THX Audio Setup” screen, then press the **ENTER** button.

```
2-7. THX Audio Setup
Boundary Gain
Compensation
▣ Surround Back
Speaker Position
Exit
```

2 Press the **CURSOR** \triangleleft or \triangleright button to select the settings according to the distances of the two surround back speakers (page 142 : **L11**), then press the **ENTER** button.

- The “THX Audio Setup” screen reappears.

```
2-7. THX Audio Setup
Set The distance
Between SBL/SBR
◀ 0ft to 1ft ▶
(0m to 0.3m)
```

3 Press the **CURSOR** Δ or ∇ button to select “Exit”, then press the **ENTER** button.

- The “Speaker Setup” menu reappears.

```
2-7. THX Audio Setup
Boundary Gain
Compensation
Surround Back
Speaker Position
▣ Exit
```

4 Press the **CURSOR** Δ or ∇ button to select the “Exit”, then press the **ENTER** button.

- The “System Setup Menu” reappears.

```
2. Speaker Setup
1. Speaker Config.
2. Subwoofer Setup
3. Delay Time
4. Channel Level
5. Crossover Frequency
6. Surround Sp Setup
7. THX Audio Setup
▣ Exit
```

Others Setup

Setting the Room EQ Setup

- Set the Room EQ setting with All or Assign for each surround mode.

1 Press the **CURSOR** Δ or ∇ button to select “Room EQ Setup” at the “Auto Setup / Room EQ” menu, then press the **ENTER** button.

- The “Room EQ Setup” screen appears.

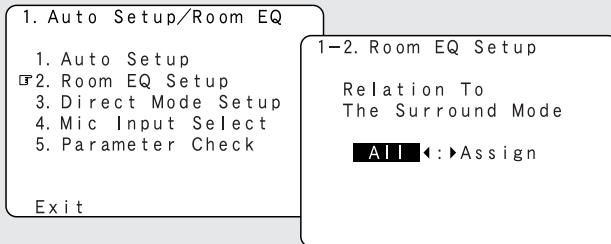

2 Press the **CURSOR** \triangleleft or \triangleright button to select “All” or “Assign”.

All:

Sets the Equalizer for all surround modes.

Assign:

Sets the Equalizer individually for each surround mode.

3 When “All” is selected:

① Press the **ENTER** button.

- The “Select the EQ Curve” screen appears.

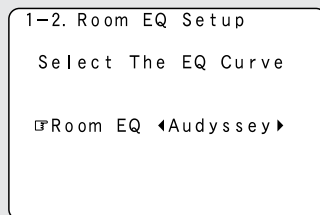

② Press the **CURSOR** \triangleleft or \triangleright button to select the equalizer setting.

OFF:

The Equalizer is not used.

Audyssey:

Adjusts the frequency response of all speakers to correct the effects of room acoustics.

Front:

Adjusts the frequency response of the surround speakers to match the characteristics of the front channel speakers.

Flat:

Adjusts the frequency response of all speakers to the flattest response. This mode is suitable for multi-channel music surround sound sources.

Manual:

Selects the setting value that was set in the Manual EQ Setup.

For details of the “Manual EQ Setup” (👉 page 118, 119).

3 When “Assign” is selected: -2 After completing system setup, select the desired equalizer setting pressing the **ROOM EQ** button.

- Equalizer settings for the individual surround modes can be stored in the memory.

- Whenever the **ROOM EQ** button is pressed, the display switches as shown below.

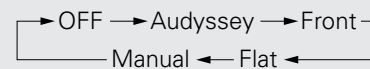

4 Press the **ENTER** button to enter the setting.

- The “Auto Setup / Room EQ” menu reappears.



- The Equalizer setting of “Audyssey”, “Front” and “Flat” can be selected after performing the Auto Setup.
- When the speaker set as “None” with the Auto Setup is changed to on manually, the equalizer of “Audyssey”, “Front” and “Flat” cannot be used.
- The Equalizer setting can be selected directly by **ROOM EQ** button.
- When headphones are connected, the Room EQ cannot be used.

Advanced Setup – Part 2

Setting the Direct Mode Setup

- Set the ON/OFF setting of Room EQ, in the case of the surround mode is in DIRECT or PURE DIRECT.

1 Press the **CURSOR** \triangle or ∇ button to select “Direct Mode Setup” at the “Auto Setup / Room EQ” menu, then press the **ENTER** button.

- The “Direct Mode Setup” screen appears.

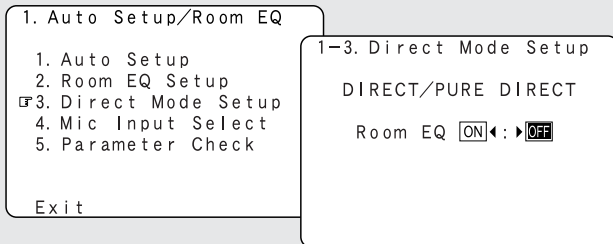

2 Press the **CURSOR** \triangleleft or \triangleright button to select “ON” or “OFF”.

3 Press the **ENTER** button to enter the setting.

- The “Auto Setup / Room EQ” menu reappears.

Setting the MIC Input Select

- Set this to switch the Mic Input jack for use for Mic jack or V.AUX L-channel input terminal.

1 Press the **CURSOR** \triangle or ∇ button to select “Mic Input Select” at the “Auto Setup / Room EQ” menu, then press the **ENTER** button.

- The “Mic Input Select” screen appears.

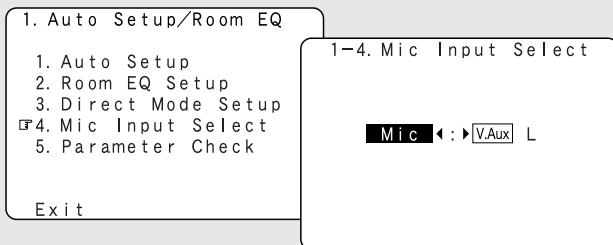

2 Press the **CURSOR** \triangleleft or \triangleright button to select “Mic” or “V.AUX L”.

3 Press the **ENTER** button to enter the setting.

- The “Auto Setup / Room EQ” menu reappears.

■ Specifications and Setup Procedure for Non-DENON Microphone

Required Microphone for DENON Auto-Setup Room EQ :
Product name Countryman B3

Required Microphone Amplifier Specification for DENON Auto-Setup Room EQ

- Gain : 29 dB
- Frequency Response : 10 ~ 30 kHz Full Flat
(Ex : Rane MS1b)

Microphone Placement

- Set the microphone using microphone stand, or other method, at the prime listening position.
- Point the top of the microphone toward the ceiling.
- Adjust the height so that the top of microphone matches the height of your ear when sitting.

Microphone Amplifier Gain Setting using Sound Level Meter and RMS Volt Meter

First you will need to adjust the “ microphone amplifier gain”.

- Connect the all speakers and the video monitor (for the on screen display) with the AVR-5805CI.
- Connect the microphone with the microphone amplifier.
- Turn on the AVR-5805CI and the “microphone amplifier”.
- Turn on the “Phantom Supply” on the microphone amplifier.
- Set the Parameter “Test Tone” to “Manual” and “Test Tone Start” to “Yes” at “Channel Level” (page 143 ~ 145).
- Once the test tone for Front Left (FL) speaker starts, check the Sound Pressure Level at the Listening Position with an SPL Meter. You do not have to check any of the other channels.
- Adjust the “Main Volume” so that the Sound Pressure Level measures 80 dB (C-weighted).
- Once the “Main Volume” as been set, connect the output of microphone amplifier to the RMS Volt Meter.
- Adjust the “microphone amplifier’s gain” as the RMS Volt Meter becomes about 120 [mV RMS].
- Once set, exit out of “System Setup” and turn off the AVR-5805CI.
- Connect the output of the microphone amplifier to the AVR-5805CI’s front panel “V.AUX” Left channel audio input-located behind Trap Door.
- Change the setting to “V.AUX L” at “Mic Input Select”.
- Start “Auto Setup” (page 20 ~ 26).

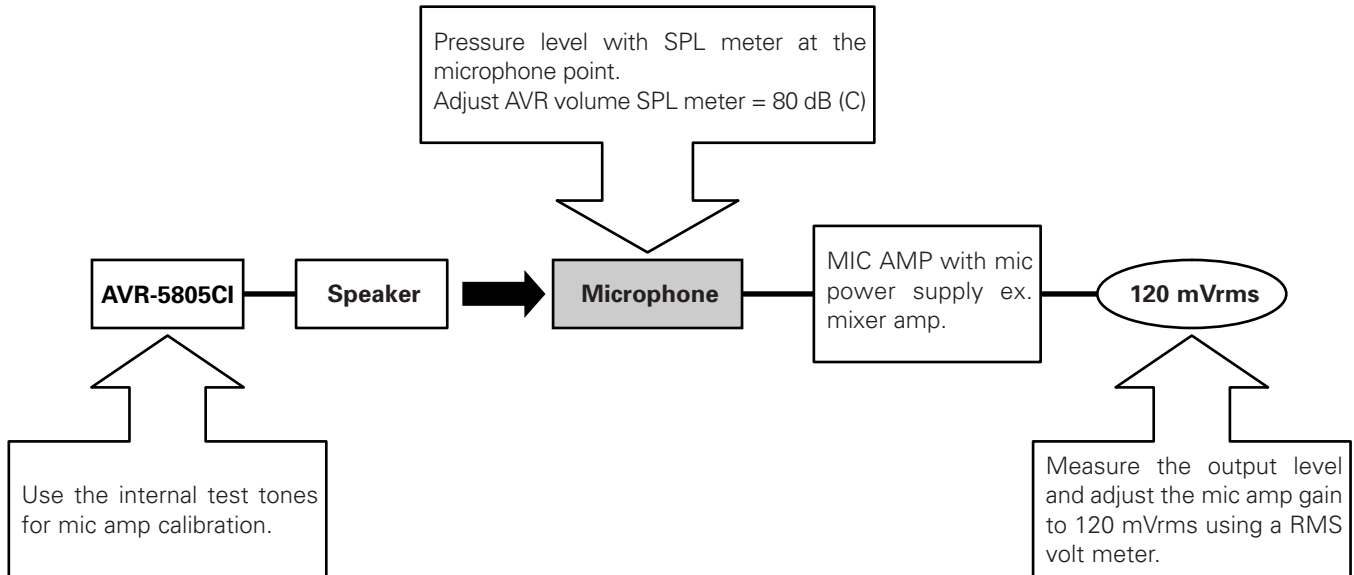

Check the parameter

- The results of the measured items can be checked.
- The EQ parameters that were set in Auto Setup can be checked.
- This item is displayed, after the measurement result of the "Auto Setup / Room EQ" is decided.

1 Press the **CURSOR** Δ or ∇ button to select "Parameter Check" at the "Auto Setup / Room EQ" menu, then press the **ENTER** button.

- The "Parameter Check" screen appears.

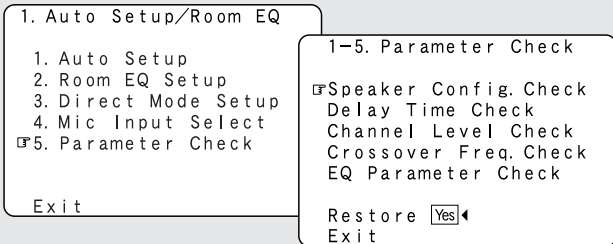

2 Press the **CURSOR** Δ or ∇ button to select the items, then press the **ENTER** button.

- The verification screen appears.

3 If the check ends, press the **ENTER** button again.

4 Press the **CURSOR** Δ or ∇ button to select "EQ Parameter Check", then press the **ENTER** button.

- The "EQ Parameter Check" screen appears.

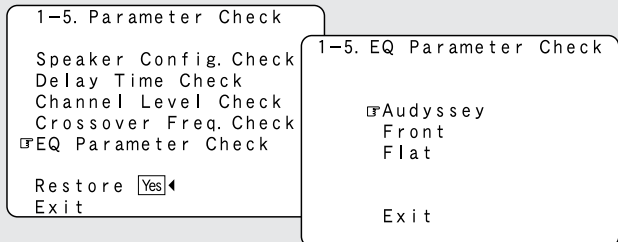

5 Press the **CURSOR** Δ or ∇ button to select the Equalizer curve, then press the **ENTER** button.

- The “EQ Check” screen appears.

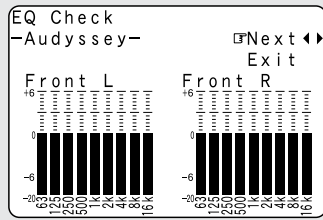

- ※ The display is only an approximate picture of the response and that correction is happening at all frequencies.

6 Press the **CURSOR** \triangleleft or \triangleright button to select the speaker channel.

7 If the check ends, press the **CURSOR** Δ or ∇ button to select “Exit”, then press the **ENTER** button.

- The “EQ Parameter Check” screen reappears.

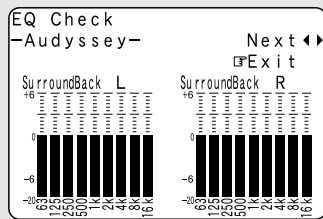

8 Press the **CURSOR** Δ or ∇ button to select “Exit”, then press the **ENTER** button.

- The “Parameter Check” screen reappears.

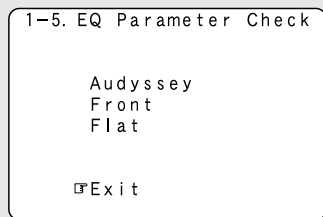

9 The results of the “Auto Setup” procedure can be reset even if the settings have been changed after performing the “Auto Setup” procedure: Press the **CURSOR** Δ or ∇ button to select “Restore Yes \triangleleft ”, then press the **CURSOR** \triangleleft button.

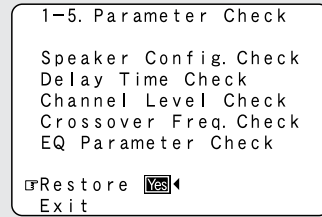

10 Press the **CURSOR** Δ or ∇ button to select “Exit”, then press the **ENTER** button.

- The “Auto Setup / Room EQ” menu reappears.

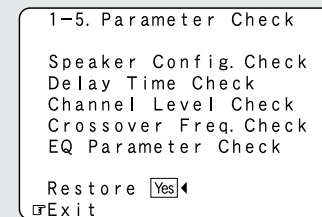

11 Press the **CURSOR** Δ or ∇ button to select “Exit”, then press the **ENTER** button.

- The “System Setup Menu” reappears.

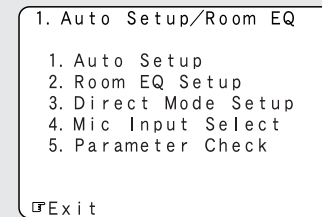

System setup items and default values (set upon shipment from the factory)

1. Auto Setup/Room EQ

Auto Setup / Room EQ		Default settings	Page	
1	Auto Setup	This unit performs an analysis of the speaker system and measures the acoustic characteristics of your room to permit an appropriate automatic setting.	-	20 - 26
2	Room EQ Setup	Set the Room EQ setting with All or Assign for each surround mode.	All, Room EQ = OFF	149
3	Direct Mode Setup	Set the ON/OFF setting of Room EQ, in the case of the surround mode is in Direct or Pure Direct.	OFF	150
4	Mic Input Select	Set this to switch the Mic Input jack for use for Mic or V.AUX L-channel input jack.	Mic	150, 151

2. Speaker Setup

Speaker Setup		Default settings	Page		
1	Speaker Configuration	Input the combination of speakers in your system and their corresponding sizes (SMALL for regular speakers, LARGE for full-size, full-range) to automatically set the composition of the signals output from the speakers and the frequency response.	Front Sp. Center Sp. Subwoofer Surround Sp. A / B Surround Back Sp.	140, 141	
			Small Small Yes Small Small / 2spkrs		
2	Subwoofer Setup	This selects the subwoofer for playing deep bass signals.	LFE —THX—	141, 142	
3	Delay Time	This parameter is for optimizing the timing with which the audio signals are produced from the speakers and subwoofer according to the listening position.	Front L & R Center Subwoofer Surround L & R (A) Surround L & R (B) Surround Back	142, 143	
			12.0 ft (3.6 m) 12.0 ft (3.6 m) 12.0 ft (3.6 m) 10.0 ft (3.0 m) 10.0 ft (3.0 m) 10.0 ft (3.0 m)		
4	Channel Level	This adjusts the volume of the signals output from the speakers and subwoofer for the different channels in order to obtain optimum effects.	Front L Front R Center Surround L (A) Surround R (A) Surround L (B) Surround R (B) Surround Back L Surround Back R Subwoofer	143 - 145	
			0 dB 0 dB 0 dB 0 dB 0 dB 0 dB 0 dB 0 dB 0 dB 0 dB		
5	Crossover Frequency	Set the frequency (Hz) below which the bass sound of the various speakers is to be output from the subwoofer.	FIXED —THX—	145, 146	
6	Surround Speaker Setup	Use this function when using multiple surround speaker combinations for more ideal surround sound. Once the combinations of surround speakers to be used for the different surround modes are preset, the surround speakers are selected automatically according to the surround mode.	Surround mode	THX/DOLBY/DTS CINEMA THX/DOLBY/DTS MUSIC THX/DOLBY GAME WIDE SCREEN 9 CH STEREO DSP SIMULATION MULTI CH MODE	146, 147
			Surround speaker	A A A A+B A+B A+B A	
7	THX Audio Setup	Boundary Gain Compensation	When using a THX Ultra2 compatible subwoofer, set the subwoofer's frequency response.	THX Ultra2 Subwoofer = NO	147
		Surround Back Speaker Position	When using two surround back speakers, set the distance of the two speakers.	The Distance Between SBL/SBR = 0 ft to 1 ft (0 m to 0.3 m)	148



Advanced Setup – Part 2

3. Audio Input Setup

Audio Input Setup			Default settings												Page		
1	Digital In Assignment	This assigns the digital input terminals for the different input sources.	Input source	CD	DVD	VDP	TV	DBS	VCR-1	VCR-2	VCR-3	VCR-4	CDR / TAPE	V.AUX	104		
			Digital Inputs	COAX 1	COAX 2	COAX 3	COAX 4	COAX 5	OPT 1	OPT 2	OPT 3	OPT 4	OPT 5	OPT 6			
2	EXT.IN Setup	Set the EXT.IN terminal playback method.	EXT.IN-1 Setup	Mode = DSP, Surr.B = NOT USED, S.Back = NOT USED, SW Level = +15 dB, Input ATT. = OFF												105	
			EXT.IN-2 Setup	Mode = DSP, SW Level = +15 dB, Input ATT. = OFF													
3	Input Function Level	The playback level is corrected individually for the different input sources.	TUNER	PHONO	CD	CDR / TAPE	DVD	VDP	TV	DBS	VCR-1	VCR-2	VCR-3	VCR-4	V.AUX	Aux	106
			0 dB	0 dB	0 dB	0 dB	0 dB	0 dB	0 dB	0 dB	0 dB	0 dB	0 dB	0 dB	0 dB	0 dB	
4	Function Rename	The names of the different input function can be changed as desired and displayed on the display.	TUNER	PHONO	CD	CDR / TAPE	DVD	VDP	TV	DBS	VCR-1	VCR-2	VCR-3	VCR-4	V.AUX	Net Audio	106, 107
5	IEEE1394 Assignment	The connected IEEE1394 device can be automatically identified to assign the input source.	-													107	
6	IEEE1394 Auto Function	Set the function for associating playback of the connected IEEE1394 device on or off.	Auto Function = OFF													108	
7	Tuner Presets	Auto Preset Memory	FM stations are received automatically and stored in the memory.	A1 ~ A8	87.5/89.1/98.1/107.9/90.1/90.1/90.1/90.1 MHz												108
				B1 ~ B8	520/600/1000/1400/1500/1710 kHz, 90.1/90.1 MHz												
				C1 ~ C8	90.1 MHz												
				D1 ~ D8	90.1 MHz												
				E1 ~ E8	90.1 MHz												
				F1 ~ F8	90.1 MHz												
	G1 ~ G8	90.1 MHz															
	Preset Skip	Preset channels that are not used often can be skipped.	All preset channels = ON													109	
	Preset Name	The preset channels can be given the names you want.	-													109	

4. Video Setup

Video Setup			Default settings								Page	
1	HDMI/DVI In Assignment	The HDMI or DVI-D input terminals are assigned for the different input sources. Select HDMI or DVI-D for the monitor output terminal. Select the HDMI audio signal playback method.	DVD	VDP	TV	DBS	VCR-1	VCR-2	VCR-3	VCR-4	V.AUX	111, 112
			NONE	NONE	NONE	NONE	NONE	NONE	NONE	NONE	NONE	
2	Component In Assignment	This assigns the color difference (component) video input terminals for the different input sources.	DVD	VDP	TV	DBS	VCR-1	VCR-2	VCR-3	VCR-4	V.AUX	112
			1-RCA	2-RCA	3-RCA	4-RCA	5-RCA	6-BNC	NONE	NONE	NONE	
3	Video Convert Mode	This sets whether or not to use the video conversion function.	ON								112	
4	HDMI/Component Out	Set the format of the signal up-converted to the HDMI monitor output or component video output terminal.	Convert = ON, Scaler = HDMI, Aspect = Full, Resolution = 480p/576p Color Space = Y Cb Cr, RGB Mode = Normal								113, 114	
5	Audio Delay	Set the audio delay timing to synchronize the sound and video.	0 ms								114	
6	On Screen Display	This sets whether or not to display the on screen display that appears on the monitor screen when the controls on the remote control unit or main unit are operated.	Function/Mode = ON, Master Volume = ON, iRadio/mServer = Always, XM = Always, Screensaver = ON, Display Mode = Mode 1								115	

5. Advanced Playback

Advanced Playback			Default settings	Page
1	2ch Direct/Stereo	The speaker settings can be changed specifically for playing in the 2 channel direct or stereo mode.	Basic	116
2	Dolby Digital Setup	Turn the audio compression on or off when down-mixing Dolby Digital signals.	OFF	117
3	Auto Surround Mode	Set the Auto surround mode function.	Auto Surround Mode = ON	117
4	Manual EQ Setup	This parameter is for optimizing the Room EQ with which the audio signals are produced from the speakers.	All Channels and Frequency = 0 dB	118, 119

6. Zone Setup

Zone Setup			Default settings						Page	
1	Speaker Configuration	Set the presence/absence of speaker combinations and the size in function of the low frequency reproduction capabilities when playing surround sound in ZONE2.	Front Sp.	Center Sp.	Subwoofer	Surround Sp.			120	
			Small	Small	Yes	Small				
2	Subwoofer Mode	This selects the subwoofer used in ZONE2 for playing the low base sound.	LFE						120	
3	Delay Time	This parameter is for optimizing the timing of the sound produced from the various speakers and subwoofer according to the listening position in ZONE2.	Front L & R	Center	Subwoofer	Surround L & R			121	
			12.0 ft (3.6 m)	12.0 ft (3.6 m)	12.0 ft (3.6 m)	10.0 ft (3.0 m)				
4	Channel Level	This adjusts the volume of the signal output from the various speakers and subwoofer used in ZONE2.	Front L	Front R	Center	Surround L	Surround R	Subwoofer	122, 123	
			0.0 dB	0.0 dB	0.0 dB	0.0 dB	0.0 dB	0.0 dB		
5	Crossover Frequency	Set the frequency (in Hz) below which deep bass appearing in the main channels will be routed to the ZONE2 subwoofer.	80 Hz						123	
6	Video Setup	Video Convert Mode	This sets whether or not to use the video conversion function.						123, 124	
		Audio Delay	Set the delay time the sound is synchronized with the picture which are output in ZONE2.							
7	Zone3/4 Tone/Ch.Level	Adjust the tone and channel level of the sound output from ZONE3 and ZONE4.	Zone3	Bass = 0 dB, Treble = 0 dB, HPF = OFF, L/R = 0 dB						124, 125
			Zone4	Bass = 0 dB, Treble = 0 dB, HPF = OFF, L/R = 0 dB						



Advanced Setup – Part 2

7. Option Setup

Option Setup				Default settings												Page						
1	Channel Setup	The number of channels that you wish to play back in each zone are assigned to each zone accordingly.		Main Zone			Zone2			Zone3			Zone4			126 ~ 128						
				9.1 CH			5.1 CH			Stereo			Stereo									
2	Power Amp Assignment	Power Amplifiers can be assigned to the various channels according to your system's requirements.		Normal												129 ~ 133						
				L1	L2	L3	L4	L5	R1	R2	R3	R4	R5									
				FL	C	SLA	SLB	SBL	FR	–	SRA	SRB	SBR									
3	Volume Control	This sets the volume level of each zone output. Volume Limit: This sets the upper limit for the master volume. Power On Level: This sets the volume level upon switching on the power of each zone. Mute Level: This sets the amount of attenuation of the audio output when each zone is muted. Volume Level: This sets whether the output level of ZONE2 to 4 is fixed or variable.		Main	Vol.Limit = OFF, P. On Lev. = LAST, Mute Lev. = FULL												134					
				Zone2	Vol.Lev. = VAR, Vol.Limit = OFF, P. On Lev. = LAST, Mute Lev. = FULL																	
				Zone3	Vol.Lev. = VAR, Vol.Limit = OFF, P. On Lev. = LAST, Mute Lev. = FULL																	
				Zone4	Vol.Lev. = VAR, Vol.Limit = OFF, P. On Lev. = LAST, Mute Lev. = FULL																	
4	Trigger Out Setup	This sets the Trigger Out output for the different input sources. If "ZONE=MAIN" is selected, settings can be made for the individual surround modes.		Trigger Out 1	ZONE = MAIN, All Surround Modes = ON												135					
					TUNER	PHONO	CD	CDR / TAPE	DVD	VDP	TV	DBS	VCR-1	VCR-2	VCR-3	VCR-4		V.AUX	Aux			
				OFF	OFF	OFF	OFF	ON	ON	ON	ON	ON	ON	ON	ON	ON		ON	ON			
				Trigger Out 2	ZONE = 2																	
					TUNER	PHONO	CD	CDR / TAPE	DVD	VDP	TV	DBS	VCR-1	VCR-2	VCR-3	VCR-4		V.AUX	Aux			
				ON	ON	ON	ON	ON	ON	ON	ON	ON	ON	ON	ON	ON		ON	ON			
				Trigger Out 3	ZONE = 3																	
					TUNER	PHONO	CD	CDR / TAPE	DVD	VDP	TV	DBS	VCR-1	VCR-2	VCR-3	VCR-4		V.AUX	Aux			
				ON	ON	ON	ON	ON	ON	ON	ON	ON	ON	ON	ON	ON		ON	ON			
				Trigger Out 4	ZONE = 4																	
					TUNER	PHONO	CD	CDR / TAPE	DVD	VDP	TV	DBS	VCR-1	VCR-2	VCR-3	VCR-4		V.AUX	Aux			
				ON	ON	ON	ON	ON	ON	ON	ON	ON	ON	ON	ON	ON		ON	ON			
				5	AC Outlet Assignment	This sets the AC outlet to on or off for the different input sources.		AC Outlet 1 ~ 3	ZONE = MAIN												136	
									TUNER	PHONO	CD	CDR / TAPE	DVD	VDP	TV	DBS		VCR-1	VCR-2	VCR-3		VCR-4
				ON	ON	ON	ON	ON	ON	ON	ON	ON	ON	ON	ON	ON		ON	ON			
				6	Setup Memory/Lock	User Memory	This stores the current user settings in the memory.		–												137	
Setup Lock	This sets whether or not to lock the system setup settings so that they cannot be changed.		Setup Lock = OFF												137							
7	Network Setup	IP Address	The IP address-related settings are made here.		DHCP = ON												138					
		Proxy	The proxy-related settings can be changed here.		OFF												139					
		Network Option	Standby Mode Power Saving	Set whether or not to accept control from the network in the standby mode.		ON												139				
			PC Language	Select the language of the computer's OS.		eng												139				

Troubleshooting

If a problem should arise, first check the following.

1. Are the connections correct?

2. Have you operated the receiver according to the Operating Instructions?

3. Are the speakers, and other connected components operating properly?

If this unit is not operating properly, check the items listed in the table below. Should the problem persist, there may be a malfunction. Disconnect the power immediately and contact your store of purchase.

Symptom	Cause	Measures	Page
Display not lit and sound not produced when power switch set to on.	<ul style="list-style-type: none"> Power supply cord not plugged in securely. 	<ul style="list-style-type: none"> Check the insertion of the power supply cord plug. 	42
Display lit but sound not produced.	<ul style="list-style-type: none"> Speaker cables not securely connected. FUNCTION knob position is not appropriate. Volume control set to minimum. Muting is on. No digital signal is being input. 	<ul style="list-style-type: none"> Connect securely. Switch to the proper position. Turn volume up to suitable level. Switch off Muting. Properly select a digital signal input source. 	16, 17 44 44 45 104
Nothing is displayed on monitor.	<ul style="list-style-type: none"> AVR-5805CI's video output terminals and monitor's input terminals are not properly connected. TV's input setting is wrong. The PURE DIRECT mode is set. 	<ul style="list-style-type: none"> Check that the connections are correct. Set the TV's input selector to the terminals to which video signals are connected. Set a surround mode other than the PURE DIRECT mode. 	16, 17, 27 ~ 42 — 50
No DTS sound is produced.	<ul style="list-style-type: none"> DVD player's audio output setting is not set to bit stream. DVD player is not DTS-compatible. AVR-5805CI's input setting is set to analog. 	<ul style="list-style-type: none"> Make the DVD player's initial settings. Use a DTS-compatible player. Set to AUTO or DTS. 	— — 47, 48
Ultra2 Cinema / THX Music Mode / THX Games Mode cannot be set.	<ul style="list-style-type: none"> Surround back speaker set to 1. 	<ul style="list-style-type: none"> Connect two surround back speakers. 	16, 17, 140, 141, 148
Copying from DVD to VCR is not possible.	<ul style="list-style-type: none"> Copying between a source such as DVD and a VCR is not usually possible, as DVDs are often encoded with copy-protection signals that prevent VCR recording. 	<ul style="list-style-type: none"> Copying is not possible. 	—
No sound is produced from subwoofer.	<ul style="list-style-type: none"> Subwoofer's power is not on. Subwoofer's initial setting is set to "NO". Subwoofer's output is not connected. The subwoofer's channel volume level is set to "OFF". 	<ul style="list-style-type: none"> Turn on the power. Set the setting to "YES". Connect properly. Turn the subwoofer's channel volume level up. 	— 140, 141 17, 42 64
No test tones are produced.	<ul style="list-style-type: none"> Surround mode is set to a mode other than STANDARD (Dolby/DTS Surround). 	<ul style="list-style-type: none"> Set to STANDARD (Dolby/DTS Surround). 	—
No sound is produced from surround speakers.	<ul style="list-style-type: none"> Surround mode is set to "STEREO". 	<ul style="list-style-type: none"> Set to a mode other than "STEREO". 	—
This unit does not operate properly when remote control unit is used.	<ul style="list-style-type: none"> Batteries dead. Remote control unit too far from this unit. Obstacle between this unit and remote control unit. Different button is being pressed. ⊕ and ⊖ ends of battery inserted in reverse. 	<ul style="list-style-type: none"> Replace with new batteries. Move closer. Remove obstacle. Press the proper button. Insert batteries properly. 	9 9 9 — 9

Troubleshooting

Symptom	Cause	Measures	Page
An image is not projected with an HDMI/DVI connection.	<ul style="list-style-type: none"> • AVR-5805CI's HDMI output terminals and monitor's input terminals are not properly connected. • No HDMI/DVI signal is being input. • The connected monitor equipment or other equipments do not support HDCP. • The output format of the connected player (HDMI/DVI FORMAT) does not matche the supported input format of connected monitor equipments. 	<ul style="list-style-type: none"> • Check the HDMI connection. • Properly select HDMI or DVI signal input source. • The AVR-5805CI will not output video signal unless the other equipment supports HDCP. • Check whether the output format of the connected player (HDMI/DVI FORMAT) matches the supported input format of connected monitor equipments. 	36, 37 111, 112 36, 37 36, 37
The HDMI audio is not output.	<ul style="list-style-type: none"> • The AVR-5805CI does not play HDMI audio signals. • The HDMI audio signals are not output from the connected monitor device. 	<ul style="list-style-type: none"> • Set the HDMI audio playback setting at the "HDMI/DVI In Assign" settings to "AMP". • Set the HDMI audio playback setting at the "HDMI/DVI In Assign" settings to "TV". 	111, 112 111, 112
Power has turned off and the power indicator is flashing red.	<ul style="list-style-type: none"> • The set's internal temperature has risen and the protection circuit has been activated. • The core wires of the speaker cables are touching each other or the AVR-5805CI's rear panel, activating the protection circuit. • AVR-5805CI is malfunctioning. 	<ul style="list-style-type: none"> • Put the AVR-5805CI in a well-ventilated place. • Turn off the power, then wait for the set to fully cool off before turning the power back on. • Check the connections of all the speaker cables. • Turn off the power and contact a DENON customer service center. 	16 16 16 16
Sound is only produced from the center speaker.	<ul style="list-style-type: none"> • You are playing a monaural source (TV, AM radio broadcast, etc.) in the DOLBY/DTS SURROUND or HOME THX CINEMA mode. 	<ul style="list-style-type: none"> • When playing monaural sources, select a surround mode other than DOLBY/DTS SURROUND or HOME THX CINEMA. 	61 ~ 63
"CHECK ANTENNA" is displayed in the XM mode.	<ul style="list-style-type: none"> • AVR-5805CI's XM terminal and the XM Mini-Tuner and Home Dock is not properly connected. 	<ul style="list-style-type: none"> • Check that the connection are correct. 	40
"NO SIGNAL" is displayed in the XM mode.	<ul style="list-style-type: none"> • The signal cannot be received. 	<ul style="list-style-type: none"> • Reposition your XM Mini-Tuner and Home Dock. 	71
"OFF AIR" is displayed in the XM mode.	<ul style="list-style-type: none"> • The selected channel is not currently broadcasting. 	<ul style="list-style-type: none"> • Select the another channel. 	72, 73
Receiving only XM channels 0 and 1.	<ul style="list-style-type: none"> • The XM Tuner is not activated. 	<ul style="list-style-type: none"> • Contact XM Satellite Radio. 	71

Additional Information

Optimum surround sound for different sources

There are currently various types of multi-channel signals (signals or formats with more than two channels).

Types of multi-channel signals

Dolby Digital (including Surround EX), DTS (including Surround ES), DVD-Audio, and Super Audio CD.

Note on the above: MUSE 3.1 and MPEG multi-channel audio are not available to North American consumers – same is true for Dolby’s AAC.

“Source” here does not refer to the type of signal (format) but the recorded content. Sources can be divided into two major categories.

Types of sources

Movie audio:

Signals created to be played in movie theaters. In general sound is recorded to be played in movie theaters equipped with multiple surround speakers, regardless of the format (Dolby Digital, DTS, etc.).

Movie theater sound field

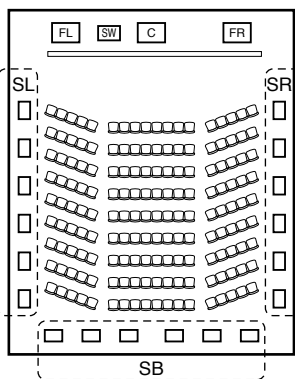

Multiple surround speakers

In this case it is important to achieve the same sense of expansion as in a movie theater with the surround channels.

To do so, in some cases the number of surround speakers is increased (to four or eight) or speakers with bipolar or dipolar properties are used.

- SL : Surround L channel
- SR : Surround R channel
- SB : Surround B (back) channel

Other types of audio:

These signals are designed to recreate a 360° sound field using three to five speakers.

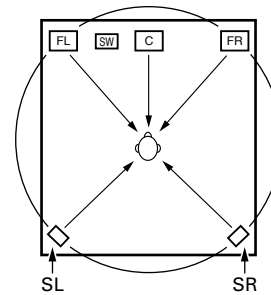

In this case the speakers should surround the listener from all sides to create a uniform sound field from 360°. Ideally the surround speakers should function as “point” sound sources in the same way as the front speakers.

These two types of sources thus have different properties, and different speaker settings, particularly for the surround speakers, are required in order to achieve the ideal sound.

The AVR-5805CI’s surround speaker selection function makes it possible to change the settings according to the combination of surround speakers being used and the surrounding environment in order to achieve the ideal surround sound for all sources. This means that you can connect a pair of bipolar or dipolar surround speakers (mounted on either side of the prime listening position), as well as a separate pair of direct radiating (monopolar) speakers placed at the rear corners of the listening room.

Listening room sound field

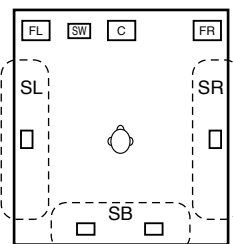

Additional Information

Surround back speakers

The THX Surround EX format adds new "Surround Back" (SB) channels to the conventional 5.1 channel system. This makes it easy to achieve sound positioned directly behind the listener, something that was previously difficult with sources designed for conventional multi surround speakers. In addition, the acoustic image extending between the sides and the rear is narrowed, thus greatly improving the expression of the surround signals for sounds moving from the sides to the back and from the front to the point directly behind the listening position.

Change of positioning and acoustic image with 5.1 channel systems

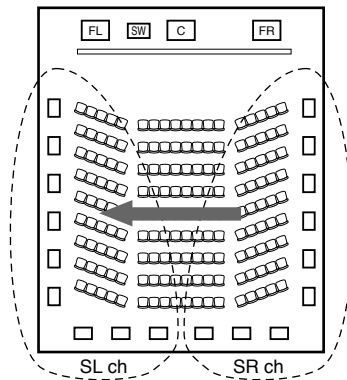

Movement of acoustic image from SR to SL

Change of positioning and acoustic image with THX Surround EX system

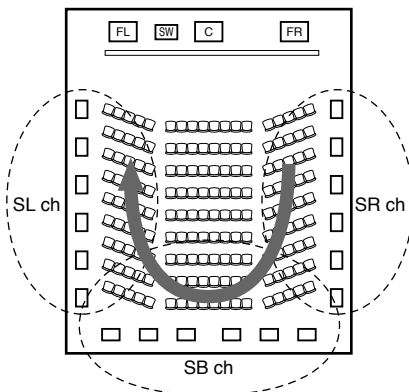

Movement of acoustic image from SR to SB to SL

Speaker(s) for one or two channels are required in order to achieve a THX Surround EX system with the AVR-5805CI. Adding these, however, allows you to achieve stronger surround effects not only with sources recorded in THX Surround EX, but also with conventional 2- to 5.1 channel sources. The WIDE SCREEN mode is a mode for achieving surround sound with up to 7.1 channels using surround back speakers, for sources recorded in conventional Dolby Surround as well as Dolby Digital 5.1 channel and DTS Surround 5.1 channel sources. Furthermore, all the Denon original surround modes (page 61 ~ 63) are compatible with 7.1 channel playback, so you can enjoy 7.1 channel sound with any signal source.

Numbers and types of surround back speakers

With THX Surround EX, the surround back channel consists of one channel of playback signals, but we recommend using two speakers. The modes that use the new ASA technology from THX (page 165) are most effective when using two monopole type surround back speakers placed close together.

Using two speakers results in a smoother blend with the sound of the surround channels and better sound positioning of the surround back channel when listening from a position other than the center.

Placement of the surround left and right channels when using surround back speakers

Using surround back speakers greatly improves the positioning of the sound at the rear. Because of this, the surround left and right channels play an important role in achieving a smooth transition of the acoustic image from the front to the back. As shown on the diagram above, in a movie theater the surround signals are also produced from diagonally in front of the listeners, creating an acoustic image as if the sound were floating in space.

To achieve these effects, we recommend placing the speakers for the surround left and right channels slightly more towards the front than with conventional surround systems. Doing so sometimes increases the surround effect when playing conventional 5.1 channel sources in the THX Surround EX mode. Check the surround effects of the various modes before selecting the surround mode.

Speaker setting examples

Here we describe a number of speaker settings for different purposes. Use these examples as guides to set up your system according to the type of speakers used and the main usage purpose.

[1] For THX Surround EX systems (using surround back speakers)

① Basic setting for primarily watching movies

This is recommended when mainly playing movies and using regular single way or 2-way speakers for the surround speakers.

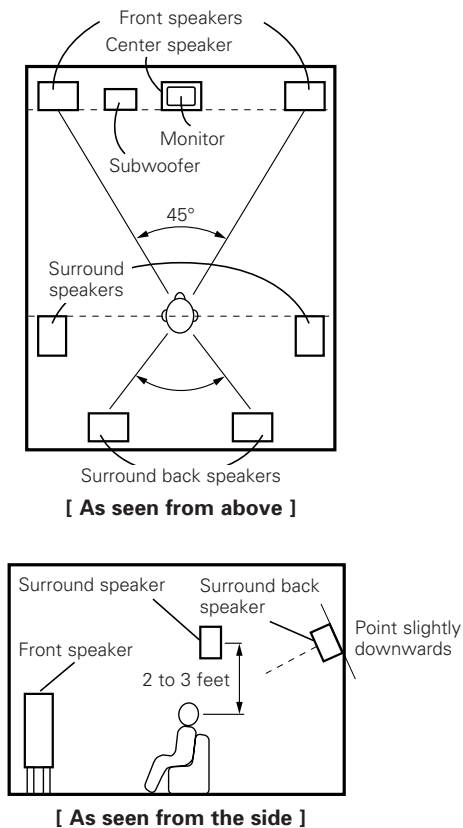

- Set the front speakers with their front surfaces as flush with the TV or monitor screen as possible. Set the center speaker between the front left and right speakers and no further from the listening position than the front speakers.
- Consult the operating instructions for your subwoofer for advice on placing the subwoofer within the listening room.
- If the surround speakers are direct-radiating (monopolar) then place them slightly behind and at an angle to the listening position and parallel to the walls at a position 2 to 3 feet (60 to 90 centimeters) above ear level at the prime listening position.

- When using two surround back speakers, set them at the back facing front and with both speakers at the same distance from the listening point. When using one surround back speaker, place it at the rear center facing the front at a slightly higher position (0 to 0.7 feet) than the surround speakers.
- We recommend installing the surround back speaker(s) at a slightly downward facing angle. This effectively prevents the surround back channel signals from reflecting off the monitor or screen at the front center, resulting in interference and making the sense of movement from the front to the back less sharp.
- Connect the surround speakers to the surround speaker A terminals on the AVR-5805CI and set settings on the setup menu to "A". (This is the factory default setting (page 153))

② Setting for primarily watching movies using diffusion type speakers for the surround speakers

For the greatest sense of surround sound envelopment, diffuse radiation speakers such as bipolar types, or dipolar (THX) types, provide a wider dispersion than is possible to obtain from a direct radiating speaker (monopolar). Place these speakers at either side of the prime listening position, mounted above ear level.

Path of the surround sound from the speakers to the listening position

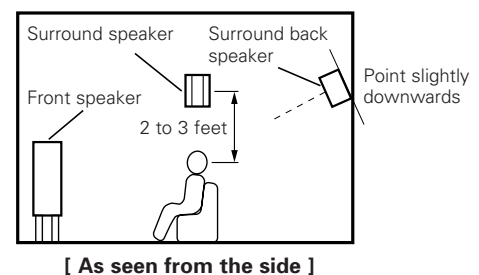
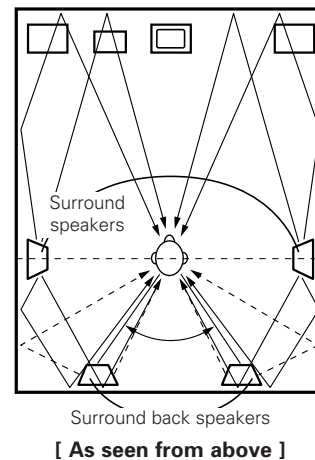

Additional Information

- Set the front speakers, center speaker and subwoofer in the same positions as in example ①.
- It is best to place the surround speakers directly at the side or slightly to the front of the viewing position, and 2 to 3 feet (60 to 90 centimeters) above the ears.
- Same as surround back speaker installation method ①.
- Connect the surround speakers to the surround speaker A terminals on the AVR-5805CI and set settings on the setup menu to "A". (This is the factory default setting (🔧 page 153))
- The signals from the surround channels reflect off the walls as shown on the diagram at the left, creating an enveloping and realistic surround sound presentation. For multi-channel music sources however, the use of bipolar or dipolar speakers mounted at the sides of the listening position may not be satisfactory in order to create a coherent 360 degree surround sound field. Connect another pair of direct radiating speakers as described in example ③ and place them at the rear corners of the room facing towards the prime listening position.

③ When using different surround speakers for movies and music

To achieve more effective surround sound for both movies and music, use different sets of surround speakers and different surround modes for the two types of sources.

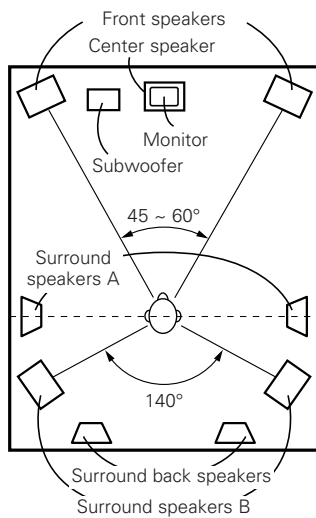

[As seen from above]

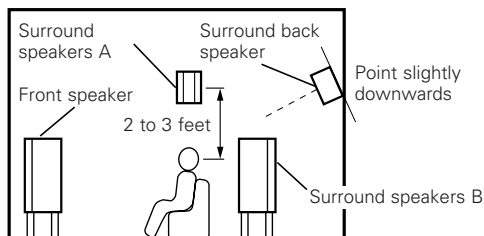

[As seen from the side]

- Set the front speakers slightly wider apart than the setup for watching movies only and point them toward the listening position in order assure clear positioning of the sound.
- Set the center speaker in the same positions as in example ①).
- Set surround speakers A for watching movies in the positions described in example ① or ②, depending on the types of speakers used.
- Set surround speakers B for playing multi-channel music at the same height as the front speakers and slightly at an angle to the rear of the listening position, and point them toward the listening position.
- Connect the surround speakers for watching movies to the surround speaker A terminals on the AVR-5805CI, the surround speakers for playing multi-channel music to the surround speaker B terminals. Set the surround speaker selection on the setup menu. (For instructions (🔧 page 146, 147))
- To activate the appropriate speakers for movies and music, we suggest that during setup, choose Dolby Digital/DTS with THX and Surround Speakers A (the bipolar or dipolar speakers mounted at the sides of the listening position). Choose Dolby Digital/DTS without THX and Surround Speakers B (the direct radiating speakers mounted at the rear corners of the listening room). Then, by simply activating the THX function (used during movie playback, the Surround A speakers are automatically activated. For multi-channel music listening (Dolby Digital or DTS music programs), turn off the THX enhancements by touching the THX button on the remote control, and the Surround B speakers will be automatically activated.

Example: Movie sources (Dolby, DTS Surround, etc.)
 "THX" or "THX 5.1" mode ... Speakers A
 Music sources (DVD video, DTS CD, etc.)
 "Dolby/DTS Surround" ... Speakers B

- ※ The speakers can be switched at the touch of a button by turning HOME THX CINEMA on when playing movies and off when playing multi-channel music.

[2] When not using surround back speakers

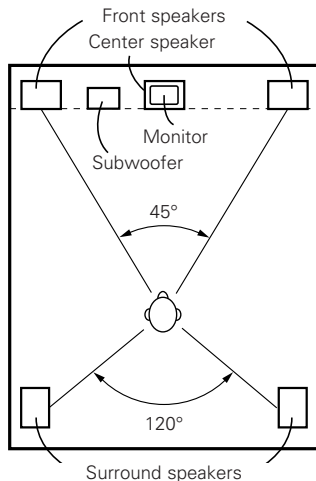

[As seen from above]

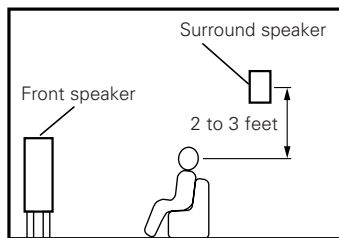

[As seen from the side]

- Set the front speakers with their front surfaces as flush with the TV or monitor screen as possible. Set the center speaker between the front left and right speakers and no further from the listening position than the front speakers.
- Consult the operating instructions for your subwoofer for advice on placing the subwoofer within the listening room.
- If the surround speakers are direct-radiating (monopolar) then place them slightly behind and at an angle to the listening position and parallel to the walls at a position 2 to 3 feet (60 to 90 centimeters) above ear level at the prime listening position.
- Connect the surround speakers to the surround speaker A terminals on the AVR-5805CI and set settings on the setup menu to "A". (This is the factory default setting (🔧 page 153))
- The surround speakers can be switched freely during playback with the surround parameter adjustment (🔧 page 45).

Surround

The AVR-5805CI is equipped with a digital signal processing circuit that lets you play program sources in the surround mode to achieve the same sense of presence as in a movie theater.

Dolby Surround

[1] Dolby Digital

Dolby Digital is the multi-channel digital signal format developed by Dolby Laboratories.

A total of 5.1 channels are played: 3 front channels ("FL", "FR" and "C"), 2 surround channels ("SL" and "SR") and the "LFE" channel for low frequencies.

Because of this, there is no crosstalk between channels and a realistic sound field with a "three-dimensional" feeling (sense of distance, movement and positioning) is achieved.

A real, overpowering sense of presence is achieved when playing movie sources in AV rooms as well.

[2] Dolby Pro Logic II

Dolby Pro Logic II is a matrix decoding technology developed by Dolby Laboratories. Regular music such as that on CDs is encoded into 5 channels to achieve an excellent surround effect.

The surround channel signals are converted into stereo and full band signals (with a frequency response of 20 Hz to 20 kHz or greater) to create a "three-dimensional" sound image offering a rich sense of presence for all stereo sources.

[3] Dolby Pro Logic IIx

Dolby Pro Logic IIx is a further improved version of the Dolby Pro Logic II matrix decoding technology.

Audio signals recorded in 2 channels are decoded to achieve a natural sound with up to 7.1 channels.

There are three modes: "Music" suited for playing music, "Cinema" suited for playing movies, and "Game" which is optimum for playing games.

[4] Dolby Headphone

This is a three-dimensional sound technology developed jointly by Dolby Laboratories and Lake Technology Ltd. of Australia for achieving surround sound using regular headphones.

Previously, when using headphones all the sounds resonated inside the head and it was uncomfortable to listen with headphones for long periods of time. Dolby Headphone simulates speaker playback in a room and places the sound at the front or the sides, outside the head, to achieve a powerful sound like the sound of movie or home theaters. This technology is mainly for multichannel audio/video equipment with Dolby Digital or Dolby Pro Logic Surround decoding functions and works with a high performance digital signal processing (DSP) chip.

Dolby Headphone is effective not only for multichannel sources but also for stereo programs.

On the AVR-5805CI, it is possible to output signals encoded in the Dolby Headphone mode from the recording output terminal and record them on a separate recorder.

Additional Information

■ Sources recorded in Dolby Surround

Sources recorded in Dolby Surround are indicated with the following logo marks.

Dolby Surround support mark: 

Manufactured under license from Dolby Laboratories. "Dolby", "Pro Logic" and the double-D symbol are trademarks of Dolby Laboratories.

DTS Digital Surround

DTS Digital Surround is a digital surround format developed by Digital Theater Systems of the United States.

The number of playback channels and the playing band is the same as for Dolby Digital (5.1 channels).

The compression rate of the audio data when it was recorded on the medium is lower than for Dolby Digital, so there is more information when the data is decoded, resulting in richer, clearer sound quality.

MANUFACTURED UNDER LICENSE FROM DIGITAL THEATER SYSTEMS, INC.
U.S. PAT. NO'S. 5,451,942; 5,956,674; 5,974,380; 5,978,762; 6,226,616; 6,487,535 AND OTHER U.S. AND WORLD-WIDE PATENTS ISSUED AND PENDING.
"DTS", "DTS-ES", "Neo:6", AND "DTS 96/24" ARE TRADEMARKS OF DIGITAL THEATER SYSTEMS, INC. © 1996, 2003 DIGITAL THEATER SYSTEMS, INC. ALL RIGHTS RESERVED.

DTS-ES™

DTS-ES is a new surround format developed by Digital Theater Systems.

A sound image and sense of positioning can be achieved by adding a surround back ("SB") channel to the conventional 5.1 channels.

DTS-ES™ Discrete 6.1:

This is the latest format, in which all 6.1 channels, including the "SB" channel, are recorded independently. Since the different channels are independent, the sound can be designed with total freedom.

DTS-ES™ Matrix 6.1:

With this format, the "SB" channel is matrix-encoded and inserted into the "SL" and "SR" channels, then decoded for the "SL", "SR" and "SB" channels upon playback. This achieves a surround sound more faithful to the artist's sound design intentions than with conventional 5.1 or 6.1 channel systems.

DTS NEO:6 surround

This is a matrix decoding technology for 6.1 channel surround playback of 2 channel sources.

The optimum decoding for the type of signal source to be played can be selected. There are two modes.

DTS NEO:6 CINEMA:

This mode is suited for playing movies. It achieves the same type of sound as in a movie theater, even with 2 channels.

DTS NEO:6 MUSIC:

This mode is suited for playing music. A natural sense of expansion is added to the sound field.

DTS 96/24

DTS 96/24 is a multi-channel digital signal format developed by Digital Theater Systems.

The sampling frequency is raised to achieve 5.1 channel playback with high quality sound (sampling frequency: 96 kHz, quantization: 24 bits).

Home THX Cinema Surround

THX is an exclusive set of standards and technologies established by the world-renowned film production company, Lucasfilm Ltd. THX grew from George Lucas' personal desire to make your experience of the film soundtrack, in both movie theaters and in your home theater, as faithful as possible to what the director intended.

Movie soundtracks are mixed in special movie theaters called dubbing stages and are designed to be played back in movie theaters with similar equipment and conditions. The soundtrack created for movie theaters is then transferred directly onto Laserdisc, VHS tape, DVD, etc., and is not changed for playback in a small home theater environment.

THX engineers developed patented technologies to accurately translate the sound from the movie theater environment into the home, correcting the tonal and spatial errors that occur. On the AVR-5805CI, when the Home THX Cinema mode is on, THX post-processing is automatically added after the Dolby Pro Logic, Dolby Digital or DTS decoder:

Re-EQ™ (Re-Equalization):

The tonal balance of a film soundtrack will be excessively bright and harsh when played back over audio equipment in the home because film soundtracks are designed to be played back in large movie theaters using very different professional equipment. Re-Equalization restores the correct tonal balance for listening to a movie soundtrack in a normal home environment.

Timbre Matching™:

The human ear changes our perception of a sound depending on the direction from which the sound is coming. In a movie theater, there is an array of surround speakers so that the surround information is all around you. In a home theater, only two speakers located to the side of your head are used. The Timbre Matching feature filters the information going to the surround speakers so that they more closely match the tonal characteristics of the sound coming from the front speakers. This ensures seamless panning between the front and surround speakers.

Adaptive Decorrelation™:

In a movie theater, a large number of surround speakers help create an enveloping surround sound experience, while in a home theater there are usually only two speakers. This can make the surround speakers sound like headphones that lack spaciousness and envelopment. The surround sounds will also collapse into the closest speaker as you move away from the middle seating position. Adaptive Decorrelation slightly changes one surround channel's time and phase relationship with respect to the other surround channel. This expands the listening position and creates—with only two speakers—the same spacious surround experience as in a movie theater.

THX Ultra2™:

Before any home theater component can be THX Ultra2 certified, it must incorporate all the features above and also pass a rigorous series of quality and performance tests. Only then can a product feature the THX Ultra2 logo, which is your guarantee that the Home Theater products you purchase will give you superb performance for many years to come. THX Ultra2 requirements cover every aspect of the product including power amplifier performance, pre-amplifier performance and operation, as well as hundreds of other parameters in both the digital and analog domain.

In addition to improvements to the power amplifier with respect to previous THX Ultra standards, three surround modes have been added: the THX Ultra2 Cinema mode, THX Music Mode and THX Games Mode.

THX Ultra2 Cinema:

THX Ultra2 Cinema mode plays 5.1 movies using all 8 speakers giving you the best possible movie watching experience. In this mode, new THX processing blends the side surround speakers and back surround speakers providing the optimal mix of ambient and directional surround sounds.

DTS-ES (Matrix and 6.1 Discrete) and Dolby Digital Surround EX encoded soundtracks will be automatically detected in Ultra2 Cinema mode if the appropriate flag has been encoded.

Some Dolby Digital Surround EX soundtracks are missing the digital flag that allows automatic switching. If you know that the movie that you are watching is encoded in Surround EX, you can manually select the THX Surround EX playback mode, otherwise THX Ultra2 Cinema mode will apply processing to provide optimum replay.

THX Music Mode:

For the replay of 5.1 multi-channel music the THX Music Mode should be selected. In this mode new THX processing is applied to the surround channels of all 5.1 encoded music sources such as DTS and Dolby Digital to provide a wide stable rear soundstage.

THX Games Mode:

For the replay of stereo and multi-channel game audio the THX Games Mode should be selected. In this mode THX ASA processing is applied to the surround channels of all 5.1 and 2.0 encoded game sources such as analog, PCM, DTS and Dolby Digital. This accurately places all game audio surround information, providing a full 360 degree playback environment. THX Games Mode is unique as it gives you a smooth transition of audio in all points of the surround field.

ASA (Advanced Speaker Array):

ASA is a proprietary THX technology which processes the sound fed to 2 side and 2 back surround speakers to provide the optimal surround sound experience. When you set up your home theater system using all eight speaker outputs (Left, Center, Right, Surround Right, Surround Back Right, Surround Back Left, Surround Left and Subwoofer) placing the two Surround Back speakers close together facing the front of the room as shown in the diagram will provide the largest sweet spot. If for practical reasons you have to place the Surround Back speakers apart, you will need to go THX Audio Set-up screen and choose the setting that most closely corresponds to the speaker spacing, which will re-optimize the surround sound-field.

ASA is used in three new modes; THX Ultra2 Cinema, THX Music Mode and THX Games Mode.

Boundary Gain Compensation:

If your chosen listening room layout (for practical or aesthetic reasons) results in the most of the listeners being close to the rear wall, the resulting bass level can be sufficiently reinforced by the boundary that the overall sound quality becomes “boomy”. THX Ultra2 receivers and controllers contain the BGC (Boundary Gain Compensation) feature to provide an improved bass balance. BGC can be selected by choosing “THX Ultra2 Subwoofer—Yes” from the “Boundary Gain Compensation” section of the THX Audio setup menu.

THX and Re-EQ, THX Timbre Matching, THX Adaptive Decorrelation, and THX Advanced Speaker Array are trademarks of THX Ltd. THX may be registered in some jurisdictions. All rights reserved.

Additional Information

■ THX™ Surround EX™

In 1999, a new surround system was launched simultaneously with the release of the movie "Star Wars Episode I". "Dolby Digital Surround EX" is a new movie sound track that greatly enhances the sense of spatial expression and the positioning of the surround channel sound. The result is 360 degrees of movement and moving sound effects that seem to pass right over the listener's head. This system was developed jointly by THX and Dolby Laboratories, fusing THX's idea of improving spatial expression and achieving a uniform 360 degree sound positioning with Dolby Laboratories' matrix encoding technology. Emphasis was placed on compatibility with the existing system Dolby Digital 5.1 channel, and the new "surround back (SB) channel" was added to achieve improvements over the conventional 5.1 channel system in terms of the positioning of the sound at the rear, the acoustic image of sound moving from the two sides to the back as well as sound moving from the front to the center rear with the multi surround speaker systems used in movie theaters, thereby enabling various types of surround sound. The surround back channel signal is a matrix-encoded signal inserted into both the Dolby Digital SL (surround left) and SR (surround right) channels. Upon playback, the signals are decoded by a high precision digital matrix decoder within the Dolby Digital decoder into the SL, SR and SB channels and output as 6.1 channels of signals. With the AVR-5805CI, the signals further undergo Home THX Cinema processing to achieve a THX Surround EX system. Even without the proper environment for playing the SB channel, Dolby Digital Surround EX signals are 100% compatible with existing 5.1 channel playback systems, so they can be played as such. In this case, the SB channel signal is produced as a monaural signal from both the SL and SR channels, so none of the signal components are missing. The effects specific to THX Surround EX (the sense of spatial expression and the positioning of the sound), however, are the same as with conventional 5.1 channel surround systems.

THX and Ultra2 are trademarks of THX Ltd. THX may be registered in some jurisdictions. All rights reserved. Surround EX is a trademark of Dolby Laboratories. Used with permission.

Audyssey MultEQ XT

Audyssey MultEQ XT is a technology designed to provide the optimum listening environment for multiple listeners within the listening area. Test data collected from multiple listening points is analyzed comprehensively and equalization that improves the sound quality for the entire listening area is performed. Audyssey MultEQ XT not only corrects frequency response problems in large listening areas, it also fully automates the surround system setup.

For a detailed description, see page 20.



- Audyssey MultEQ XT is a trademark of Audyssey Laboratories. It is licensed under US and National Patent Applications 20030235318 and 10/700,220. Additional U.S. and Foreign Patents pending. MultEQ and the Audyssey MultEQ logo are trademarks of Audyssey Laboratories, Inc.. All rights reserved.

HDCD® (High Definition Compatible Digital®)

HDCD is an encoding/decoding technology that greatly reduces the distortion that occurs upon digital recording while maintaining compatibility with the conventional CD format, thus expanding the dynamic range and achieving a high resolution. Conventional CDs and HDCD compatible CDs are identified automatically to select the optimum digital processing.



- ®, HDCD®, High Definition Compatible Digital® and Microsoft® are either registered trademarks or trademarks of Microsoft Corporation, Inc. in the United States and/or other countries. HDCD system manufactured under license from Microsoft Corporation, Inc. This product is covered by one or more of the following: In the USA: 5,479,168, 5,638,074, 5,640,161, 5,808,574, 5,838,274, 5,854,600, 5,864,311, 5,872,531, and in Australia: 669114. Other patents pending.

About IEEE1394

IEEE1394 is an international standard established by the "IEEE" (Institute of Electrical and Electronics Engineers) of the United States.

The AVR-5805CI can be connected to an IEEE1394 compatible device using an IEEE1394 cable to enable digital transfer of multi-channel audio sources (DVD Audio discs, Super Audio CDs, etc.) with a single cable.

- The AVR-5805CI's transfer format is compatible with A&M protocol.
In addition to A&M protocol, IEEE1394 transfer formats also include MPEG-TS, DV, etc.
- The AVR-5805CI is compatible with a data transfer speed of up to S400.
The IEEE1394 maximum data transfer speeds are defined as approximately 100, 200 or 400 Mbps, expressed respectively as S100, S200 and S400. When S100 or S200 devices are connected, the actual transfer rate may be slower than 400 Mbps, depending on the device's specifications. As far as possible, interconnect devices with the same maximum data transfer rate.
- The AVR-5805CI is compatible with the DTCP (Digital Transmission Content Protection) system.

■ Copyright protection system

In order to play the sound of DVD Audio discs, Super Audio CDs or DVDs (aside from freely copiable discs) using IEEE1394 connections, both the player and receiver must be compatible with the DTCP (Digital Transmission Content Protection) system.

DTCP is a copy protection technology that involves data encryption and authentication of the other device. Refer to your player's operating instructions.

The AVR-5805CI's IEEE1394 device interface is designed based on the standards below.

- 1) IEEE Std. 1394a-2000, Standard for High Performance Serial Bus
 - 2) Audio and Music Data Transmission Protocol 2.0
- It is compatible with IEC60958 bit stream, DVD-Audio and Super Audio CD within AM824 sequence adaptation layers within these standards.

About HDMI

"HDMI" is the abbreviation of "High-Definition Multimedia Interface".

This is a digital interface standard for next generation TVs developed based on the DVI (Digital Visual Interface) used for computer displays, etc., and optimized for use in non-professional equipment. With it, non-compressed digital video and multi-channel audio signals can be transferred with a single connector, eliminating the need to use separate cables for the picture and sound and making it possible to make connectors smaller. HDMI is also compatible with HDCP (High-bandwidth Digital Contents Protection), a technology for protecting copyrights that encrypts digital video signals in the same way as with DVI.

HDMI

- HDMI, the HDMI logo and High-Definition Multimedia Interface are trademarks or registered trademarks of HDMI Licensing LLC.

DENON LINK

DENON LINK is a DENON-exclusive digital link for transmitting high speed, high sound quality digital audio signals with no loss in of signal.

High quality sound playback is possible by connecting to a DENON DVD player with a DENON LINK terminal.

Advanced AL24 Processing

■ Equipped with "Advanced AL24 Processing" – time base area data quantity extension

In addition to "AL24 Processing Plus", the conventional bit extension technology, the PCM signal (CD/digital) playback system also includes the newly developed "Advanced AL24 Processing", a unique high speed signal detection and processing technology that greatly improves the amount of data in the time base area. In addition to extension of the original 16-bit data into 24 bits, "Advanced AL24 Processing" conducts data interpolation on the time axis, in other words up-convert sampling, to achieve natural interpolation processing without harming the original data. In addition, the digital filter offers expanded flexibility, including pulse response with no ringing. Optimum filtering processing is performed even for pulsive music data and attack sounds. All this makes it possible to recreate the delicate nuances of the music and such space information as the positions of the performers, the width, height and depth of the place of the performance (stage), and so on.

Windows Media Connect

This is a media server provided free of charge by Microsoft since October 2004.

It operates with all types of music jukebox programs, but is optimum with Windows Media Player Ver. 10.

Windows Media Connect can be used to play playlists created on jukebox software such as Windows Media Player Ver. 10, as well as WMA, DRM WMA, MP3 and WAV files.

■ Explanation for installing Windows Media Connect

1. If installation of Windows XP Service Pack 2 is not yet complete, either download free of charge from Microsoft or via the Windows Update installer.
2. Download the latest version of Windows Media Player Ver. 10 either directly from Microsoft or using the Windows Update installer.
3. Download Windows Media Connect (usable since October 12, 2004) either directly from Microsoft or using the Windows Update installer.

vTuner

This is an Internet radio free online contents server. Note that usage fees are included in upgrade costs.

For inquiries about this service, visit the vTuner site below.

vTuner website: <http://www.radiodemon.com>

This product is protected by certain intellectual property rights of Nothing Else Matters Software and BridgeCo. Use or distribution of such technology outside of this product is prohibited without a license from Nothing Else Matters Software and BridgeCo or an authorized subsidiary.

Windows Media DRM

A copyright-protected technology developed by Microsoft.

- The PlaysForSure logo, Windows Media and the Windows logo are trademarks or registered trademarks of Microsoft Corporation in the United States and/or other countries.
- Content providers are using the digital rights management technology for Windows Media contained in this device ("WM-DRM") to protect the integrity of their content ("Secure Content") so that their intellectual property, including copyright, in such content is not misappropriated. This device uses WM-DRM software to play Secure Content ("WM-DRM Software"). If the security of the WM-DRM Software in this device has been compromised, owners of Secure Content ("Secure Content Owners") may request that Microsoft revoke the WM-DRM Software's right to acquire new licenses to copy, display and/or play Secure Content. Revocation does not alter the WM-DRM Software's ability to play unprotected content. A list of revoked WM-DRM Software is sent to your device whenever you download a license for Secure Content from the Internet or from PC. Microsoft may, in conjunction with such license, also download revocation list onto your device on behalf of Secure Content Owners.

Surround modes and parameters

Surround Mode	Signals and adjustability in the different modes														EFFECT LEVEL	
	Channel output										Parameter (default values are shown in parentheses)					ROOM SIZE
	FRONT L/R	CENTER	SURROUND L/R	SURROUND BACK L/R	SUB-WOOFER	D. COMP *1	LFE *2	AFDM *2	SB CH OUT (MODE)	STONE CONTROL	CINEMA EQ.	MODE (DECODER)				
PURE DIRECT, DIRECT	○	×	×	×	⊗	○ (OFF)	○ (0 dB)	×	×	×	×	×	×	×	×	×
DSD DIRECT	○	×	×	×	⊗	×	○ (0 dB)	×	×	×	×	×	×	×	×	×
DSD MULTI DIRECT	○	⊗	⊗	⊗	⊗	×	○ (0 dB)	×	○	×	×	×	×	×	×	×
MULTI CH DIRECT	○	⊗	⊗	⊗	⊗	×	○ (0 dB)	○ (ON)	○	×	×	×	×	×	×	×
STEREO	○	×	×	×	⊗	○ (OFF)	○ (0 dB)	×	×	○ (0 dB)	×	×	×	×	×	×
EXT. IN	○	⊗	⊗	⊗	⊗	×	×	×	×	×	×	×	×	×	×	×
MULTI CH IN	○	⊗	⊗	⊗	⊗	×	○ (0 dB)	○ (ON)	○	○ (0 dB)	×	×	×	×	×	×
WIDE SCREEN	○	⊗	⊗	⊗	⊗	○ (OFF)	○ (0 dB)	×	○	○ (0 dB)	○ (OFF)	×	×	×	○ (ON, 10)	×
HOME THX CINEMA (2ch)	○	⊗	⊗	⊗	⊗	×	×	×	○	×	×	×	×	×	×	×
HOME THX CINEMA (5.1ch)	○	⊗	⊗	⊗	⊗	×	○ (0 dB)	○ (ON)	○	×	○ (PLI x C)	×	×	×	×	×
DOLBY PRO LOGIC IIx	○	⊗	⊗	⊗	⊗	○ (OFF)	×	×	○	○ (0 dB)	○ (CINEMA)	×	×	×	×	×
DOLBY PRO LOGIC II	○	⊗	⊗	⊗	⊗	○ (OFF)	×	×	○	○ (0 dB)	○ (CINEMA)	×	×	×	×	×
DTS NEO:6	○	⊗	⊗	⊗	⊗	○ (OFF)	×	×	○	○ (0 dB)	○ (CINEMA)	×	×	×	×	×
DOLBY DIGITAL	○	⊗	⊗	⊗	⊗	○ (OFF)	○ (0 dB)	○ (ON)	○	○ (0 dB)	○ (NOTE3)	×	×	×	×	×
DTS SURROUND	○	⊗	⊗	⊗	⊗	○ (OFF)	○ (0 dB)	○ (ON)	○	○ (0 dB)	○ (NOTE4)	×	×	×	×	×
9CH STEREO	○	⊗	⊗	⊗	⊗	○ (OFF)	○ (0 dB)	○ (ON)	○	○ (0 dB)	○ (NOTE3)	×	×	×	×	×
SUPER STADIUM	○	⊗	⊗	⊗	⊗	○ (OFF)	○ (0 dB)	×	○	○ (0 dB)	○ (OFF)	×	×	×	×	×
ROCK ARENA	○	⊗	⊗	⊗	⊗	○ (OFF)	○ (0 dB)	×	○	○ (NOTE1)	×	×	×	○ (Medium)	×	○ (10)
JAZZ CLUB	○	⊗	⊗	⊗	⊗	○ (OFF)	○ (0 dB)	×	○	○ (NOTE2)	×	×	×	○ (Medium)	×	○ (10)
CLASSIC CONCERT	○	⊗	⊗	⊗	⊗	○ (OFF)	○ (0 dB)	×	○	○ (0 dB)	×	×	×	○ (Medium)	×	○ (10)
MONO MOVIE	○	⊗	⊗	⊗	⊗	○ (OFF)	○ (0 dB)	×	○	○ (0 dB)	×	×	×	○ (Medium)	×	○ (10)
VIDEO GAME	○	⊗	⊗	⊗	⊗	○ (OFF)	○ (0 dB)	×	○	○ (0 dB)	×	×	×	○ (Medium)	×	○ (10)
MATRIX	○	⊗	⊗	⊗	⊗	○ (OFF)	○ (0 dB)	×	○	○ (0 dB)	×	×	×	○ (Medium)	×	×
VIRTUAL	○	×	×	×	⊗	○ (OFF)	○ (0 dB)	×	×	○ (0 dB)	×	×	×	×	×	×

- : Signal / Adjustable
- × : No signal / Not adjustable
- ⊗ : Turned on or off by speaker configuration setting
- : Able
- × : Unable
- NOTE1 : BASS +6 dB, TREBLE 0 dB
- NOTE2 : BASS +6 dB, TREBLE +4 dB
- NOTE3 : This parameter is available when the "MODE" is set to "CINEMA".
- NOTE4 : This parameter is available when the "MODE" is set to "CINEMA" or "PL".
- *1 : When playing Dolby Digital and DTS signals.
- *2 : When playing Dolby Digital, DTS, DVD-Audio and Super Audio CD.



Surround Mode	Signals and adjustability in the different modes Parameter (default values are shown in parentheses)									
	Dolby Digital		DELAY TIME	SUBWOOFER ON/OFF	PRO LOGIC II/IIx MUSIC MODE only			NEO:6 MUSIC MODE only	EXT. IN only	
	NIGHT mode				PANORAMA	DIMENSION	CENTER WIDTH			CENTER IMAGE
PURE DIRECT, DIRECT	○ (OFF)		×	○	×	×	×	×	×	×
DSD DIRECT	×		×	○	×	×	×	×	×	×
DSD MULTI DIRECT	×		×	×	×	×	×	×	×	×
MULTI CH DIRECT	×		×	×	×	×	×	×	×	×
STEREO	○ (OFF)		×	×	×	×	×	×	×	×
EXT. IN	×		×	×	×	×	×	○	×	×
MULTI CH IN	×		×	×	×	×	×	×	×	×
WIDE SCREEN	○ (OFF)		×	×	×	×	×	×	×	×
HOME THX CINEMA (2ch)	○ (OFF)		×	×	×	×	×	×	×	×
HOME THX CINEMA (5.1ch)	○ (OFF)		×	×	×	×	×	×	×	×
DOLBY PRO LOGIC IIx	○ (OFF)		×	×	○ (OFF)	○ (3)	×	○ (3)	×	×
DOLBY PRO LOGIC II	○ (OFF)		×	×	○ (OFF)	○ (3)	×	○ (3)	×	×
DTS NEO:6	○ (OFF)		×	×	×	×	×	×	○ (0.3)	×
DOLBY DIGITAL	○ (OFF)		×	×	×	×	×	×	×	×
DTS SURROUND	×		×	×	×	×	×	×	×	×
9CH STEREO	○ (OFF)		×	×	×	×	×	×	×	×
SUPER STADIUM	○ (OFF)		×	×	×	×	×	×	×	×
ROCK ARENA	○ (OFF)		×	×	×	×	×	×	×	×
JAZZ CLUB	○ (OFF)		×	×	×	×	×	×	×	×
CLASSIC CONCERT	○ (OFF)		×	×	×	×	×	×	×	×
MONO MOVIE	○ (OFF)		×	×	×	×	×	×	×	×
VIDEO GAME	○ (OFF)		×	×	×	×	×	×	×	×
MATRIX	○ (OFF)		○ (30 msec)	×	×	×	×	×	×	×
VIRTUAL	○ (OFF)		×	×	×	×	×	×	×	×

○ : Signal / Adjustable
 × : No signal / Not adjustable
 ◎ : Turned on or off by speaker configuration setting



Additional Information

■ Differences in surround mode names depending on the input signals

Surround Mode	Note	Input signals										Super Audio CD							
		ANALOG	LINEAR PCM	DTS ES DSCRT (With Flag)	DTS ES MTRX (With Flag)	DTS (5.1ch)	DTS 96/24	DOLBY DIGITAL EX (With Flag)	DOLBY DIGITAL EX (With no Flag)	DOLBY DIGITAL (5.1ch)	DOLBY DIGITAL (3, 4, 5ch)	DOLBY DIGITAL (2ch)	DVD-Audio (multi ch)	DVD-Audio (2ch)	176.4/192kHz	DSD (multi ch)	DSD (2ch)		
HOME THX CINEMA																			
ES DSCR6.1 + THX	*1	×	⊙	×	×	×	×	×	×	×	×	×	×	×	×	×	×	×	
ES MTRX6.1 + THX	*1	×	×	⊙	×	×	×	⊙	×	×	×	×	×	×	×	×	×	×	×
THX SURROUND EX	*1	×	×	×	×	×	×	⊙	×	×	×	×	×	×	×	×	×	×	×
THX Ultra2 Cinema	*2	×	×	⊙	⊙	⊙	⊙	⊙	⊙	⊙	⊙	⊙	⊙	⊙	⊙	⊙	⊙	⊙	⊙
THX Music Mode	*2	×	×	⊙	⊙	⊙	⊙	⊙	⊙	⊙	⊙	⊙	⊙	⊙	⊙	⊙	⊙	⊙	⊙
THX Games mode	*2	×	×	⊙	⊙	⊙	⊙	⊙	⊙	⊙	⊙	⊙	⊙	⊙	⊙	⊙	⊙	⊙	⊙
THX 5.1		×	×	⊙	⊙	⊙	⊙	⊙	⊙	⊙	⊙	⊙	⊙	⊙	⊙	⊙	⊙	⊙	⊙
PLIIx C + THX	*4	○	○	○	○	○	○	○	○	○	○	○	○	○	○	○	○	○	○
PLII C + THX		○	○	×	×	×	×	×	×	×	×	×	×	×	×	×	×	×	×
DOLBY PL + THX		○	○	×	×	×	×	×	×	×	×	×	×	×	×	×	×	×	×
NEO6 + THX		○	○	×	×	×	×	×	×	×	×	×	×	×	×	×	×	×	×
STANDARD																			
DTS SURROUND																			
DTS ES DSCR6.1	*1	×	×	●	×	×	×	×	×	×	×	×	×	×	×	×	×	×	×
DTS ES MTRX6.1	*1	×	×	×	●	×	×	×	×	×	×	×	×	×	×	×	×	×	×
DTS SURROUND		×	×	○	○	○	○	○	○	○	○	○	○	○	○	○	○	○	○
DTS 96/24		×	×	×	×	●	×	×	×	×	×	×	×	×	×	×	×	×	×
DTS + PLIIx CINEMA	*2	×	×	○	○	○	○	○	○	○	○	○	○	○	○	○	○	○	○
DTS + PLIIx MUSIC	*1	×	×	○	○	○	○	○	○	○	○	○	○	○	○	○	○	○	○
DTS + NEO6	*1	×	×	○	○	○	○	○	○	○	○	○	○	○	○	○	○	○	○
DTS NEO6 CINEMA		○	○	×	×	×	×	×	×	×	×	×	×	×	×	×	×	×	×
DTS NEO6 MUSIC		○	○	×	×	×	×	×	×	×	×	×	×	×	×	×	×	×	×
DOLBY SURROUND																			
DOLBY DIGITAL EX	*1	×	×	×	×	×	×	○	○	○	○	○	○	○	○	○	○	○	○
DOLBY DIGITAL		×	×	×	×	×	×	○	○	●	○	○	○	○	○	○	○	○	○
DOLBY DIGITAL+PLIIx CINEMA	*2	×	×	×	×	×	×	○	○	○	○	○	○	○	○	○	○	○	○
DOLBY DIGITAL+PLIIx MUSIC	*1	×	×	×	×	×	×	○	○	○	○	○	○	○	○	○	○	○	○
DOLBY PRO LOGIC IIX CINEMA		○	○	×	×	×	×	×	×	×	×	×	×	×	×	×	×	×	×
DOLBY PRO LOGIC IIX MUSIC		○	○	×	×	×	×	×	×	×	×	×	×	×	×	×	×	×	×
DOLBY PRO LOGIC IIX GAME		○	○	×	×	×	×	×	×	×	×	×	×	×	×	×	×	×	×
DOLBY PRO LOGIC IIX CINEMA		○	○	×	×	×	×	×	×	×	×	×	×	×	×	×	×	×	×
DOLBY PRO LOGIC II MUSIC		○	○	×	×	×	×	×	×	×	×	×	×	×	×	×	×	×	×
DOLBY PRO LOGIC II GAME		○	○	×	×	×	×	×	×	×	×	×	×	×	×	×	×	×	×
DOLBY PRO LOGIC		○	○	×	×	×	×	×	×	×	×	×	×	×	×	×	×	×	×
MULTI CH IN																			
MULTI CH IN		×	×	×	×	×	×	×	×	×	×	×	×	×	×	×	×	×	×
MULTI IN + PLIIx CINEMA	*2	×	×	×	×	×	×	×	×	×	×	×	×	×	×	×	×	×	×
MULTI IN + PLIIx MUSIC	*1	×	×	×	×	×	×	×	×	×	×	×	×	×	×	×	×	×	×



Button	Input signals											Super Audio CD				
	ANALOG	LINEAR PCM	DTS			DOLBY DIGITAL				DVD-AUDIO		DSD (multi ch)	DSD (2ch)			
Note			DTS ES DSCRT (With Flag)	DTS ES MTRX (With Flag)	DTS (5.1ch)	DTS 96/24	DOLBY DIGITAL EX (With Flag)	DOLBY DIGITAL EX (With no Flag)	DOLBY DIGITAL (5.1ch)	DOLBY DIGITAL (3, 4, 5ch)	DOLBY DIGITAL (2ch)	DVD-Audio (multi ch)	DVD-Audio (2ch)	176.4/192kHz		
DIRECT	○	○	○	○	○	○	○	○	○	○	○	○	○	○	○	○
DSD DIRECT	×	×	×	×	×	×	×	×	×	×	×	×	×	×	×	×
DSD MULTI DIRECT	×	×	×	×	×	×	×	×	×	×	×	×	×	×	×	×
MULTI CH DIRECT	×	×	×	×	×	×	×	×	×	×	×	×	×	×	×	×
M DIRECT + PLIIx CINEMA	×	×	×	×	×	×	×	×	×	×	×	×	×	×	×	×
M DIRECT + PLIIx MUSIC	×	×	×	×	×	×	×	×	×	×	×	×	×	×	×	×
PURE DIRECT	○	○	○	○	○	○	○	○	○	○	○	○	○	○	○	○
DSD PURE DIRECT	×	×	×	×	×	×	×	×	×	×	×	×	×	×	×	×
DSD MULTI PURE	×	×	×	×	×	×	×	×	×	×	×	×	×	×	×	×
MULTI CH PURE DIRECT	×	×	×	×	×	×	×	×	×	×	×	×	×	×	×	×
M PURE D + PLIIx CINEMA	×	×	×	×	×	×	×	×	×	×	×	×	×	×	×	×
M PURE D + PLIIx MUSIC	×	×	×	×	×	×	×	×	×	×	×	×	×	×	×	×
DSP SIMULATION																
WIDE SCREEN	○	○	○	○	○	○	○	○	○	○	○	○	○	○	○	○
SUPER STADIUM	○	○	○	○	○	○	○	○	○	○	○	○	○	○	○	○
ROCK ARENA	○	○	○	○	○	○	○	○	○	○	○	○	○	○	○	○
JAZZ CLUB	○	○	○	○	○	○	○	○	○	○	○	○	○	○	○	○
CLASSIC CONCERT	○	○	○	○	○	○	○	○	○	○	○	○	○	○	○	○
MONO MOVIE	○	○	○	○	○	○	○	○	○	○	○	○	○	○	○	○
VIDEO GAME	○	○	○	○	○	○	○	○	○	○	○	○	○	○	○	○
MATRIX	○	○	○	○	○	○	○	○	○	○	○	○	○	○	○	○
VIRTUAL	○	○	○	○	○	○	○	○	○	○	○	○	○	○	○	○
9CH STEREO	○	○	○	○	○	○	○	○	○	○	○	○	○	○	○	○
STEREO	●	●	○	○	○	○	○	○	○	○	○	○	○	○	○	○
STEREO	●	●	○	○	○	○	○	○	○	○	○	○	○	○	○	○

- : Mode selectable in initial status
- ◎ : Mode fixed when AFDM is ON
- : Selectable mode
- × : Non-selectable mode

NOTE :

- *1: This mode is not available when the Surround Back speaker setup is set to "None".
- *2: This mode is not available when the Surround Back speaker setup is set to "1spkr" or "None".
- *3: If the Surround Back speaker setup is set to "None" and/or the surround (B) speaker setup is set to "None", then "7CH STEREO" or "5CH STEREO" is displayed.
- *4: For input signals other than 2 channel signals, this mode cannot be selected when surround back speaker is set to "1spkr" or "None".



Additional Information

Relationship between the video input signal and monitor output according to the video convert mode settings of MAIN ZONE

Video convert	Input signals				MONITOR OUT			
	HDMI	COMPONENT	S-VIDEO	VIDEO	HDMI	COMPONENT	S-VIDEO	VIDEO
ON	X	X	X	X	X	X	X	X
	X	X	X	O	VIDEO	VIDEO	VIDEO	VIDEO
	X	X	O	X	S-VIDEO	S-VIDEO	S-VIDEO	S-VIDEO
	X	X	O	O	S-VIDEO	S-VIDEO	S-VIDEO	S-VIDEO
	X	O (1080p)	X	X	X	COMPONENT	X	X
	X	O (480p ~ 720p)	X	X	COMPONENT	COMPONENT	X	X
	X	O (480i/576i)	X	X	COMPONENT	COMPONENT	COMPONENT	COMPONENT
	X	O (1080p)	X	O	VIDEO	COMPONENT *1	VIDEO	VIDEO
	X	O (480p ~ 720p)	X	O	COMPONENT *1	COMPONENT *1	VIDEO *3	VIDEO
	X	O (480i/576i)	X	O	COMPONENT *1	COMPONENT *1	COMPONENT *1	VIDEO
	X	O (1080p)	O	X	S-VIDEO	COMPONENT *2	S-VIDEO	S-VIDEO
	X	O (480p ~ 720p)	O	X	COMPONENT *2	COMPONENT *2	S-VIDEO	S-VIDEO
	X	O (480i/576i)	O	X	COMPONENT *2	COMPONENT *2	S-VIDEO	S-VIDEO
	X	O (1080p)	O	O	S-VIDEO	COMPONENT *2	S-VIDEO	S-VIDEO
	X	O (480p ~ 720p)	O	O	COMPONENT *2	COMPONENT *2	S-VIDEO	S-VIDEO
	X	O (480i/576i)	O	O	COMPONENT *2	COMPONENT *2	S-VIDEO	S-VIDEO
	O	X	X	X	HDMI	X	X	X
	O	X	X	O	HDMI	VIDEO *2	VIDEO	VIDEO
	O	X	O	X	HDMI	S-VIDEO *2	S-VIDEO	S-VIDEO
	O	X	O	O	HDMI	S-VIDEO *2	S-VIDEO	S-VIDEO
	O	O (1080p)	X	X	HDMI	COMPONENT	X	X
	O	O (480p ~ 720p)	X	X	HDMI	COMPONENT	X	X
	O	O (480i/576i)	X	X	HDMI	COMPONENT	COMPONENT	COMPONENT
	O	O (1080p)	X	O	HDMI *1	COMPONENT *1	VIDEO	VIDEO
	O	O (480p ~ 720p)	X	O	HDMI *1	COMPONENT *1	VIDEO *3	VIDEO
	O	O (480i/576i)	X	O	HDMI *1	COMPONENT *1	COMPONENT *1	VIDEO
	O	O (1080p)	O	X	HDMI *2	COMPONENT *2	S-VIDEO	S-VIDEO
	O	O (480p ~ 720p)	O	X	HDMI *2	COMPONENT *2	S-VIDEO	S-VIDEO
	O	O (480i/576i)	O	X	HDMI *2	COMPONENT *2	S-VIDEO	S-VIDEO
	O	O (1080p)	O	O	HDMI *2	COMPONENT *2	S-VIDEO	S-VIDEO
O	O (480p ~ 720p)	O	O	HDMI *2	COMPONENT *2	S-VIDEO	S-VIDEO	
O	O (480i/576i)	O	O	HDMI *2	COMPONENT *2	S-VIDEO	S-VIDEO	

O : Signal input
 X : No signal
 480p ~ 720p : 480p/576p/1080i/720p

X : Not output
 *1 : On screen display superimposed on video signal and output.
 *2 : On screen display superimposed on S-Video signal and output.
 *3 : Video signals are not output when the analog to HDMI convert function is set to "ON".
 ■ : On screen display only displayed for **SYSTEM SETUP, SURROUND PARAMETER** (except the HDMI monitor out) and **ON SCREEN** button.
 ■ : When "OFF" is selected for the "Analog to HDMI Convert" setting, no video signals other than the HDMI input signal are output.
 □ : Including the contents of ■ and ■ above.



- The MAIN ZONE video conversion function is compatible with the following format: NTSC, PAL, SECAM, NTSC4.43, PAL-N, PAL-M and PAL-60.
- When SECAM signals of video input are up-converted, the signals are output in PAL format from the S-Video terminal.
- When the input signal is set to component video 1080p, the signals cannot be output to the HDMI monitor output terminal.

- **HDMI MONITOR OUT:**
 When there is no HDMI input signal and "HDMI" is selected for the "Scaler" setting, the signal is output as set with the "Resolution" setting.
 When "Component" is selected for the "Scaler" setting, the signal is output with the same resolution as the input signal.
- **COMPONENT MONITOR OUT:**
 When "Component" is selected for the "Scaler" setting, the signal is output as set with the "Resolution" setting. However, the output resolution is limited to a maximum of 480p/576p if the input signal is copyright-protected.

Video convert	S-VIDEO MONITOR OUT	Input signals				MONITOR OUT			
		HDMI	COMPONENT	S-VIDEO	VIDEO	HDMI	COMPONENT	S-VIDEO	VIDEO
OFF	-	X	X	X	X	X *1	X *1	X *1	X
	-	X	X	X	○	X *1	X *1	X *1	VIDEO
	-	X	X	○	X	X *2	X *2	S-VIDEO	X *2
	Used	X	X	○	○	X *2	X *2	S-VIDEO	VIDEO *2
	Not used	X	X	○	○	X *1	X *1	S-VIDEO *1	VIDEO
	-	X	○	X	X	X *1	COMPONENT *1	X *1	X
	-	X	○	X	○	X *1	COMPONENT *1	X *1	VIDEO
	-	X	○	○	X	X *2	COMPONENT *2	S-VIDEO	X *2
	Used	X	○	○	○	X *2	COMPONENT *2	S-VIDEO	VIDEO *2
	Not used	X	○	○	○	X *1	COMPONENT *1	S-VIDEO *1	VIDEO
	-	○	X	X	X	HDMI *1	X *1	X *1	X
	-	○	X	X	○	HDMI *1	X *1	X *1	VIDEO
	-	○	X	○	X	HDMI *2	X *2	S-VIDEO	X *2
	Used	○	X	○	○	HDMI *2	X *2	S-VIDEO	VIDEO *2
	Not used	○	X	○	○	HDMI *1	X *1	S-VIDEO *1	VIDEO

○ : Signal input
 X : No signal

X : Not output
 *1 : On screen display superimposed on video signal and output.
 *2 : On screen display superimposed on S-Video signal and output.
 (Grey background) : On screen display only displayed for **SYSTEM SETUP, SURROUND PARAMETER** (except the HDMI monitor out) and **ON SCREEN** button.



- When "Analog to HDMI Convert" is set to "OFF", no signals other than the HDMI input signals are output to the HDMI monitor output terminal.

Relationship between the video input signal and monitor output according to the VIDEO CONVERT MODE settings of ZONE2

VIDEO CONVERT Mode	Input signals			MONITOR OUT		
	COMPONENT	S-VIDEO	VIDEO	COMPONENT	S-VIDEO	VIDEO
ON	X	X	○	VIDEO	VIDEO	VIDEO
	X	○	X	S-VIDEO	S-VIDEO	S-VIDEO
	X	○	○	S-VIDEO	S-VIDEO	S-VIDEO
	○	X	X	COMPONENT	X	X
	○	X	○	COMPONENT *1	VIDEO	VIDEO
	○	○	X	COMPONENT *2	S-VIDEO	S-VIDEO

VIDEO CONVERT Mode	S-VIDEO MONITOR OUT	Input signals			MONITOR OUT		
		COMPONENT	S-VIDEO	VIDEO	COMPONENT	S-VIDEO	VIDEO
OFF	-	X	X	○	X	X	VIDEO
	-	X	○	X	X	S-VIDEO	X
	Used	X	○	○	X	S-VIDEO	* VIDEO
	Not used	X	○	○	X	-	VIDEO
	-	○	X	X	COMPONENT	X	X
	-	○	X	○	COMPONENT *1	X	VIDEO
	-	○	○	X	COMPONENT *2	S-VIDEO	X
	Used	○	○	○	COMPONENT *2	S-VIDEO	* VIDEO

○ : Signal input
 X : No signal

X : Not output
 * VIDEO : No on screen display
 COMPONENT : On screen display only displayed for **SYSTEM SETUP, SURROUND PARAMETER** and **ON SCREEN** button.
 COMPONENT *1 : On screen display superimposed on video signal and output
 COMPONENT *2 : On screen display superimposed on S-Video signal and output

- The ZONE2 video conversion function is compatible with the NTSC and PAL formats.



Specifications

■ Audio section

• Power amplifier

Rated output:

Front:

170 W + 170 W (8 Ω/ohms, 20 Hz ~ 20 kHz with 0.05 % T.H.D.)

200 W + 200 W (6 Ω/ohms, 20 Hz ~ 20 kHz with 0.05 % T.H.D.)

Center:

170 W (8 Ω/ohms, 20 Hz ~ 20 kHz with 0.05 % T.H.D.)

200 W (6 Ω/ohms, 20 Hz ~ 20 kHz with 0.05 % T.H.D.)

Surround (A, B):

170 W + 170 W (8 Ω/ohms, 20 Hz ~ 20 kHz with 0.05 % T.H.D.)

200 W + 200 W (6 Ω/ohms, 20 Hz ~ 20 kHz with 0.05 % T.H.D.)

Surround Back:

170 W + 170 W (8 Ω/ohms, 20 Hz ~ 20 kHz with 0.05 % T.H.D.)

200 W + 200 W (6 Ω/ohms, 20 Hz ~ 20 kHz with 0.05 % T.H.D.)

Dynamic power:

190 W x 2 ch (8 Ω/ohms)

310 W x 2 ch (4 Ω/ohms)

All channels 6 ~ 16 Ω/ohms

Output terminals:

• Analog

Input sensitivity / input impedance:

200 mV / 47 kΩ/kohms

Frequency response:

10 Hz ~ 100 kHz: +0, -3 dB (DIRECT mode)

S/N:

105 dB (DIRECT mode)

Distortion:

0.005 % (20 Hz ~ 20 kHz) (DIRECT mode)

Rated output:

1.2 V

• Digital

D/A output:

Rated output — 2 V (at 0 dB playback)

Total harmonic distortion — 0.003 % (1 kHz, at 0 dB)

S/N ratio — 125 dB

Dynamic range — 117 dB

Format — Digital audio interface

Digital input:

• Phono equalizer (PHONO input — REC OUT)

Input sensitivity:

2.5 mV

RIAA deviation:

±1 dB (20 Hz to 20 kHz)

S/N:

74 dB (A weighting, with 5 mV input)

Rated output / Maximum output:

150 mV / 8 V

Distortion factor:

0.03 % (1 kHz, 3 V)

■ Video section

• Standard video terminals

Input / output level and impedance:

1 Vp-p, 75 Ω/ohms

Frequency response:

5 Hz ~ 10 MHz — +0, -3 dB

• S-Video terminals

Input / output level and impedance:

Y (brightness) signal — 1 Vp-p, 75 Ω/ohms

C (color) signal — 0.286 Vp-p, 75 Ω/ohms

Frequency response:

5 Hz ~ 10 MHz — +0, -3 dB

• Color component video terminal

Input / output level and impedance:

Y (brightness) signal — 1 Vp-p, 75 Ω/ohms

P_B/C_B signal — 0.7 Vp-p, 75 Ω/ohms

P_R/C_R signal — 0.7 Vp-p, 75 Ω/ohms

Frequency response:

5 Hz ~ 100 MHz — +0, -3 dB

Specifications

■ Tuner section		
Receiving Range:	[FM] (note: μV at 75 Ω /ohms, 0 dBf = 1×10^{-15} W)	[AM]
Usable Sensitivity:	87.5 MHz ~ 107.9 MHz	520 kHz ~ 1710 kHz
50 dB Quieting Sensitivity:	1.0 μV (11.2 dBf)	18 μV
	MONO 1.6 μV (15.3 dBf)	
	STEREO 23 μV (38.5 dBf)	
S/N (IHF-A):	MONO 77 dB	50 dB
	STEREO 72 dB	
Total Harmonic Distortion (at 1 kHz):	MONO 0.15 %	
	STEREO 0.3 %	
■ General		
Power supply:	AC 120 V, 60 Hz	
Power consumption:	13 A	
	1 W Max (Standby)	
Maximum external dimensions:	434 (W) x 280 (H) x 505 (D) mm (17-3/32" x 11-1/32" x 19-7/8")	
Mass:	44.0 kg (97 lbs)	
■ Remote control unit (RC-1036)		
Batteries:	LR6/AA Type (two batteries)	
External dimensions:	63 (W) x 238 (H) x 31 (D) mm (2-31/64" x 9-3/8" x 1-7/32")	
Mass:	190 g (Approx. 6.7 oz) (including batteries)	

* For purposes of improvement, specifications and design are subject to change without notice.

List of preset codes / Liste de codes pré-réglés

DVD

3D Lab	40539	Bush	40516, 40672, 40690, 40695, 40699, 40713, 40717, 40730, 40778, 40831, 40833, 40884, 41051, 41165
Acoustic Solutions	40713, 40730, 41242	C-Tech	40798
Advent	41016	Cambridge Soundworks	40690
AEG	40770, 40790	Cat	40699, 41087
AFK	41051	CAVS	41057
Afreey	40698	CCE	40730
Aim	40699, 40778, 40833, 41165	Celestial	41020
Airis	41250	Centrex	40672, 41004
Aiwa	40533, 40641	Centrum	40713
Akai	40690, 40705, 40770, 40790, 40884, 40899, 41089, 41115	CGV	41115
Akira	40699	Changhong	40627, 41061
Akura	41051	Cinea	40831
Alba	40539, 40672, 40695, 40699, 40713, 40717, 40730, 40783, 41051	Cineral	40730
Alco	40790	Cinetec	40713
Allegro	40869	cineULTRA	40699
Amitech	40770, 40784, 40850	CineVision	40833, 40869, 40876
Amphion Media Works	40872	Citizen	41277
Amstrad	40713	Classic	40730, 41730
AMW	40872	Clatronic	40672, 41165
Ansonic	40774, 40831	Clayton	40713
Apex	40672, 41061	Coby	40730, 40770, 40778, 40852, 41086, 41107, 41115, 41165, 41177, 41351
Apex Digital	40672, 40717, 40755, 40794, 40796, 40797, 40830, 41004, 41020, 41056, 41061, 41100	Compacks	40826, 41265
Arianet	40770	Conia	40516, 40672, 40798, 40852, 41004
Aspire Digital	41168, 41407	Continental Edison	40768, 40831
Audiosonic	40690, 41265	Craig	40831
Audiovox	40717, 40790, 41041, 41071, 41072, 41121, 41122	Crown	40690, 40769, 40770, 41115
Awa	40730, 40872	Curtis Mathes	41087
Axion	40730, 41071, 41072	Cybercom	40831
B & K	40655, 40662	CyberHome	40816, 40874, 41023, 41024, 41117, 41129
Basic Line	40713	Cydectin	41074
Baze	41165	Cytron	40651, 40774
Bellagio	41004	D-Vision	41115
Black Diamond	40698, 40713, 40833, 40884	Daenyx	40872
Blaupunkt	40717	Daewoo	40705, 40770, 40784, 40833, 40869, 40872, 41169, 41172, 41234, 41242
Blue Parade	40571	Daewoo International	40872
Blue Sky	40651, 40672, 40695, 40713, 40769, 40778, 40804	Dansai	40770, 40783, 41115
Boghe	41004	Dantax	40539, 40713, 40790, 41089
Boman	40783	Daytek	40872
Brainwave	40770, 41115	Dayton	40872
Brandt	40503, 40651	DCE	40831
Broksonic	40695, 40868	DEC	40774, 40778
		Decca	40770, 41115
		Denon	40490, 40634, * [41470] , 41634

Denver	40699, 40778, 41107, 41165, 41353, 41359
Desav	40770
Desay	40800, 41407
Diamond	40651, 40768, 40790
Dick Smith Electronics	40833, 41730
Digihome	40713
digiRED	40717
Digitor	40651, 40690
Digitrex	40672, 41056, 41100
DIGIXmedia	40826
DiK	40774, 40831
Disney	40675, 41270
DiViDo	40705
DK Digital	40831
DMTech	40783
Dragon	40831
DSE	40833, 41730
Dual	40651, 40713, 40730, 40783, 40790, 40831, 41068, 41085
Durabrand	40713, 40831, 41003, 41127
DVD2000	40521
DVX	40768
ECC	40730
Electrohome	40770, 40784
Elfunk	40850
Elin	40770
Ellion	40850
Elta	40672, 40690, 40770, 40850, 41051, 41115
Emerson	40591, 40675, 40705, 40816, 40821, 41268
Encore	40698
Enterprise	40591
Enzer	40770, 40784
EuroLine	41115
Fenner	40651, 40769
Ferguson	40651
Finlux	40591, 40672, 40741, 40770, 40783, 41165
Fintec	40784, 41169
Firstline	40651, 40713, 40869
Fisher	40670
Funai	40675, 40695, 41334
Gateway	41073, 41077, 41158
GE	40522, 40717, 40815
General Electric	40717
Global Solutions	40768
Go Video	40715, 40741, 40744, 40783, 40833, 40869, 41044, 41075, 41099, 41144, 41158, 41304, 41730
Go Vision	41071, 41072
GoldStar	40591, 40741

Goodmans	40651, 40690, 40713, 40730, 40783, 40790, 40833, 41004, 41730
GPX	40699, 40769
Gradiente	40651
Gran Prix	40831
Grandin	40672, 40713
Greenhill	40717
Grundig	40539, 40651, 40670, 40695, 40705, 40713, 40790, 41004, 41730
Grunkel	40770
GVG	41169
H & B	40850
H&B	40713, 40850
Hanseatic	40741, 40783
Harman/Kardon	40582, 40702
HDT	40705
Hen	40713
Hher	40651, 40713, 40826, 40831
Hitachi	40573, 40664, 40695, 40713, 41247
Hiteker	40672, 40872
Home Electronics	40730
Home Tech	41107
Humax	40646
Hyundai	40768, 40783, 40850
I-Lo	41348
iLo	41348
Initial	40717, 40839
Integra	40571, 40627, 41634
IRT	40783
ISP	40695
Jaton	41078
JBL	40702
Jeken	40699
Jensen	41016
Jepssen	41250
JMB	40695
JNC	40672
JSI	41423
JVC	40503, 40539, 40558, 40623, 40867, 41164
jWin	41049, 41051
Karcher	40783
Kawasaki	40790
Kendo	40699, 40713, 40831
Kennex	40713, 40770
Kenwood	40490, 40534
Kiiro	40770
KLH	40717, 40790, 41020, 41149
KLH Digital	40717
Konka	40711, 40719, 40720, 40721
Koss	40651, 40896, 41423

Landel	40826
Lasonic	40798, 41173
Lawson	40768
Lenco	40651, 40699, 40713, 40770, 40774, 40778, 41165
Lenoxx	40690, 41127
Lexia	40699, 40768
LG	40591, 40741, 40790, 40801, 40869, 40036
Lifetec	40651, 40831
Limit	40768
LiteOn	41058, 41158, 41416, 41440
Loewe	40511, 40539, 40741
Logix	40705, 40783
Lumatron	40705, 40741, 40833, 41115
Lunatron	40741
Luxman	40573
Luxor	40713, 41004, 41730
Magnasonic	40651, 40769
Magnavox	40503, 40539, 40646, 40675, 40713, 40821
Magnex	41165
Malata	40782, 41159
Manhattan	40705, 40713
Marantz	40539
Mark	40713
Marquant	40770
Matsui	40651, 40672, 40695, 40713, 40884, 41004, 41730
Maxim	40713, 40872
MBO	40690, 40730, 41730
MDS	40778
Mecotek	40770
Medion	40630, 40651, 40770, 40774, 40783, 40820, 40831
MEI	40790
Memorex	40695, 40831, 41270
Metronic	40690
Metz	40525, 40571, 40713
Micromedia	40503, 40539
Micromega	40539
Microsoft	40522
Microstar	40831
Minato	40752
Minax	40713
Minerva	40705
Minoka	40770
Minowa	41165
Mintek	40717, 40839
Mirror	40752
Mitsubishi	40521, 40713, 41403, 41521
Mizuda	40770

Momitsu	41082
MTLogic	41265
Mustek	40730, 41730
Mx Onda	40651
NAD	40591, 40692, 40741
Naiko	40770, 41004
Narita	41115
NEC	40591, 40692, 40785, 40869, 41404
Nesa	40717
Nevir	40770, 40831
NextBase	40826
NexxTech	41402
Nintaus	41051
Norcent	40872, 41003, 41107, 41265
Nordmende	40774, 40831
Noriko	40752
Nu-Tec	40516
Okano	40752
Olidata	40672
Omni	40690, 40698, 40778, 40833
Onix	40672, 40852
Onkyo	40503, 40627, 40792
Oopla	41158
Optimus	40525
OptoMedia Electronics	40896
Orion	40695
Oritron	40651
Ormond	40713
Otic	40826
P&B	40770
Pacific	40695, 40713, 40768, 40774, 40790, 40804, 40831
Packard Bell	40770
Palladium	40695
Palsonic	40672, 40852
Panasonic	40490, 40503, 40703, 41362, 41462, 41490, 41762
Panda	40717
Philco	40690, 40790
Philips	40503, 40539, 40646, 40675, 40854, 41158, 41260, 41267, 41354
Phonotrend	40672, 40699, 41165
Pioneer	40490, 40525, 40571, 40631
Plu2	40850
Pointer	40784
Polaroid	41020, 41061, 41086
Polk Audio	40539
Portland	40770
Powerpoint	40872

Powtek	40852
Prima	41016
Prinz	40831
Prism	40705
Proline	40651, 40672, 40833, 41004
Proscan	40522
Proson	40713
Prosonic	40752
ProVision	40699, 40778
Qwestar	40651
Radionette	40741, 40869
RCA	40522, 40571, 40717, 40769, 40790, 40822, 41022, 41132
REC	40490
Recco	40698
Red Star	40770, 41003
Reoc	40752, 40768
Resonance	40651
Revoy	40699
Rio	40869
RJTech	41360
Roadstar	40690, 40699, 40713, 40730, 40833, 41051
Ronin	40872
Rotel	40558, 40623
Rowa	40516, 40717, 40823, 40872, 41004
Saba	40651, 40769
Sabaki	40798
Saivod	40831
Sakyno	40768
Salora	40741
Sampo	40698, 40752
Samsung	40490, 40573, 40744, 40820, 40899, 41044, 41075
Sansui	40695, 40768, 40784
Sanyo	40670, 40695, 40873
Scan	40705, 40850
ScanMagic	40730
Schaub Lorenz	40770, 41115
Schneider	40539, 40651, 40705, 40713, 40774, 40783, 40790, 40804, 40831
Schwaiger	40752
Scientific Labs	40768, 40798
Scott	40651, 40672, 40797
SEG	40713, 40768, 40798, 40872, 40884
Semp	40503
Sensory Science	41158
Shanghai	40672
Sharp	40630, 40675, 40713, 40752, 41256
Sharper Image	41117
Sherwood	40633, 40717, 40741, 40770, 41043, 41077

Shinco	40717
Shinsonic	40533, 40839
Silva	40831
Silva Schneider	40831
Singer	40690, 40768
Skantic	40539, 40713, 41003
Skymaster	40730, 40768
Slim Art	40784
Slim Devices	40533
SM Electronic	40690, 40730, 40768
Smart	40705, 40713
Sonai	40755
Sonashi	40831
Sonic Blue	40783, 40869, 41099
Sony	40533, 40573, 40864, 41033, 41431, 41533
Soundmaster	40768
Soundmax	40768
Soundwave	40783
Sova	41122
Spectra	40872
Standard	40651, 40768, 40831
Star Cluster	40768
Strong	40713
Sungale	41074
Sunkai	40770, 40850
Sunstech	40831
Superscan	40821
Supervision	40768
SVA	40672, 40717, 40860, 41105
Sylvania	40630, 40675, 40821, 41268
Symphonic	40675
Synn	40768
Tandberg	40713
Tatung	40770
Teac	40516, 40571, 40692, 40695, 40717, 40741, 40768, 40790, 40809, 40833, 41051
Technics	40490, 40703
Technika	40768, 40770, 40831, 41115, 41165
Technisson	41115
Technosonic	40730, 41051, 41115
Techwood	40692, 40713
Tedelex	40690, 40768, 41004
Telefunken	40770, 40790, 40833
Teletech	40713, 40768
Tensai	40651, 40690, 40770
Terapin	41031
Tevion	40651, 40768, 40798, 40833
Theta Digital	40571
Thomson	40522
Tokai	40698, 40784, 40790

Tokaido	40698
Toshiba	40503, 40695, 41045, 41154
Trans Continens	40826
TRANS-continents	40826, 40831, 40872
Trasonic	40672, 40730, 41165
Tredex	40800, 40803, 40804
Trio	40770, 40784
TYT	40705
Umax	40690
United	40672, 40695, 40768, 40826, 40852, 41115, 41165
Universal Multimedia	40768
Universum	40591, 40713, 40741, 40869
Urban Concepts	40503
US Logic	40839
V	41064
Venturer	40790
Vestel	40713
Vieta	40705
VInc	41064, 41226
Vizio	41064, 41226
Vocopro	41027
Voxson	40690, 40730, 40774, 40831
Walkvision	40717
Welkin	40831
Wellington	40713
Wesder	40699
Wharfedale	40698, 40752, 40768, 40790
Wilson	40831
Windsor	40713
Windy Sam	40573
WIZE	41115
Xbox	40522
Xenius	40651, 40790
XLogic	40768, 40798
XMS	40770
Xoro	41173, 41250
Yakumo	41004, 41056
Yamada	40872, 41004, 41056, 41158
Yamaha	40490, 40539, 40545, 40646
Yamakawa	40872
Yukai	40730, 41730
Zenith	40503, 40591, 40741, 40869
Zeus	40784
Zoece	41265

DVDR

Apex Digital	41056
Aspire Digital	41168
Coby	41086

CyberHome	41129
Denon	40490
Dick Smith Electronics	41730
Digitrex	41056
DSE	41730
Funai	40675, 41334
Gateway	41073, 41158
Go Video	40741, 41158, 41304, 41730
iLo	41348
JVC	41164
LG	40741
LiteOn	41158, 41416, 41440
Loewe	40741
Magnavox	40646
Mitsubishi	41403
Mustek	41730
NEC	41404
Panasonic	40490
Philips	40646, 41158
Pioneer	40631
Polaroid	41086
RCA	40522
Samsung	40490
Sensory Science	41158
Sharp	40675
Sony	41033, 41431
Sylvania	40675
Zenith	40741

VCR

ABS	21972
Accent	20072
Admiral	20048, 20209, 20479
Adventura	20000
Adyson	20072
Aiko	20278
Aim	20209, 20278, 20642
Aiwa	20000, 20032, 20037, 20124, 20209, 20315, 20348, 20479
Akai	20037, 20041, 20081, 20175, 20240, 20315, 20348, 20642
Akashi	20072
Akiba	20072
Akura	20072
Alba	20000, 20072, 20081, 20209, 20278, 20315, 20348
Alienware	21972
Allstar	20081
America Action	20278

American High	20035
Amoisonic	20479
Amstrad	20000, 20072, 20278
Anam	20037, 20162, 20226, 20240, 20278
Anam National	20162, 20226, 21562
Anitech	20072
Ansonic	20000
Apelsound	20209
Aristona	20081
ASA	20037, 20081
Asha	20240
Asuka	20037, 20038
Audiosonic	20072, 20278
Audiovox	20037, 20278
Awa	20037, 20043, 20278, 20642
Baird	20000, 20041, 20104
Basic Line	20046, 20072, 20104, 20278
Beaumarck	20240
Beko	20104
Bell & Howell	20104
Bestar	20278
Black Diamond	20081, 20642
Black Panther	20278
Blaupunkt	20081, 20162, 20226
Blue Sky	20037, 20072, 20209, 20278, 20348, 20642
Bondstec	20072
Brandt	20041, 20320
Brandt Electronic	20041
Brandt Electronique	20041
Brinkmann	20209, 20348
Broksonic	20002, 20121, 20184, 20209, 20348, 20479, 21479
Bush	20000, 20072, 20081, 20209, 20278, 20315, 20348, 20642
Calix	20037
Canon	20035
Carena	20209
Carrefour	20045
Carver	20081
Casio	20000
Cathay	20278
CCE	20072, 20278
CGE	20000
Changhong	20048, 20081
Cimline	20072
Cineral	20278
Citizen	20037, 20278, 21278
Clatronic	20000, 20072
Colt	20072
Condor	20278

Craig	20037, 20047, 20072, 20240
Crown	20037, 20072, 20278
Curtis Mathes	20035, 20041, 20060, 20162, 21035
Cybernex	20240
CyberPower	21972
Cyrus	20081
Daewoo	20045, 20046, 20104, 20209, 20278, 20642, 21278
Dansai	20072, 20278
Daytron	20278
De Graaf	20042, 20046, 20048, 20081, 20104
Decca	20000, 20067, 20081, 20209, 20348
Deitron	20278
Dell	21972
Denko	20072
Denon	20042
Diamant	20037
Diamond	20209, 20348
Dick Smith Electronics	20642
Digitor	20642
DirecTV	20739
Domland	20209
DSE	20642
Dual	20000, 20041, 20081, 20278, 20348
Dumont	20000, 20081, 20104
Durabrand	20038, 20039
Dynatech	20000
Elbe	20038, 20278
Elcotech	20072
Electrohome	20037
Electroponic	20037
Elin	20240
Elsay	20072
Elta	20072, 20278
Emerex	20032
Emerson	20000, 20002, 20035, 20037, 20043, 20045, 20072, 20121, 20184, 20209, 20240, 20278, 20294, 20479, 21278, 21479
ESC	20240, 20278
Ferguson	20000, 20041, 20278, 20320
Fidelity	20000, 20072, 20240, 20278, 20432
Finlandia	20000, 20037, 20042, 20043, 20046, 20048, 20081, 20104, 20226
Finlux	20000, 20042, 20081, 20104, 20315
Firstline	20037, 20043, 20045, 20072, 20209, 20278, 20348
Fisher	20046, 20047, 20104
Flint	20209, 20348
Frontech	20072

Fuji	20033, 20035
Fujitsu	20000, 20045
Fujitsu General	20037
Funai	20000, 21333
Galaxis	20278
Garrard	20000
Gateway	21972
GE	20035, 20048, 20060, 20209, 20226, 20240, 20320, 20807, 21035, 21060
GEC	20081
General	20045
General Technic	20348
Genexxa	20104
Gessen	20278
Go Video	20432
GoldHand	20072
GoldStar	20037, 20038, 20209, 20225, 20226, 20348, 21237
Goodmans	20000, 20037, 20072, 20081, 20209, 20278, 20348, 20642
GPX	20037
Gradiente	20000
Graetz	20041, 20104, 20240
Granada	20000, 20037, 20042, 20046, 20048, 20081, 20104, 20226, 20240
Grandin	20000, 20037, 20072, 20209, 20278
Gronic	20104
Grundig	20072, 20081, 20226, 20320, 20347, 20348
Haaz	20348
Hanseatic	20037, 20038, 20081, 20209
Haojie	20240
Harley Davidson	20000
Harman/Kardon	20038, 20081
Harwood	20072
HCM	20072
Headquarter	20046
Hewlett Packard	21972
Hher	20278, 20642
HI-Q	20047
Hinari	20041, 20072, 20240, 20278
Hischito	20045
Hitachi	*[20000] , 20037, 20041, 20042, 20046, 20081, 20089, 20240, 20040
Hornyphon	20081
Howard Computers	21972
HP	21972
Hughes Network Systems	20042, 20739
Humax	20739
Hush	21972

Hypson	20000, 20037, 20072, 20209, 20278
iBUYPOWER	21972
Imperial	20000
Ingersoll	20209, 20240
Inno Hit	20072, 20432
inotech	20278
Interbuy	20072
Interfunk	20081, 20104
Internal	20278
International	20037, 20278, 20642
Intervision	20000, 20209, 20278
IR	20041, 20042, 20045, 20047, 20072, 20081, 20104, 20209, 20226, 20240, 20348
Irradio	20072, 20081
ITT	20041, 20046, 20104, 20240
ITV	20037, 20278
JBL	20278
Jensen	20041
JMB	20209, 20348
Joyce	20000
JVC	20041, 20045, 20067, 20081, 21008, 21283
Kaisui	20072
Kambrook	20037
Karcher	20081, 20278
KEC	20037, 20278
Kendo	20072, 20209, 20278, 20315, 20348, 20642
Kenwood	20038, 20041, 20067
KIC	20000
Kimari	20047
Kioto	20348
KLH	20072
Kneissel	20037, 20209, 20278, 20348
Kodak	20035, 20037
Kolin	20041, 20043
Kolster	20209
Korpel	20072
Kuba Electronic	20047
Kyoto	20072
Lenco	20278
Leyco	20072
LG	20037, 20038, 20042, 20045, 20209, 21237
Lifetec	20209, 20348
Linksys	21972
Lloyd's	20000
Loewe	20037, 20081, 20162, 21562
Logik	20072, 20209, 20240
Lux May	20072
Luxor	20043, 20046, 20047, 20048, 20104, 20315
LXI	20037
M Electronic	20000, 20038

Magnasonic	20278, 21278
Magnavox	20000, 20035, 20039, 20081, 20149, 20642, 21781
Magnin	20240
Magnum	20642
Manesth	20045, 20072, 20081, 20209
Marantz	20035, 20038, 20081, 20209
Mark	20000, 20278
Marta	20037
Mastec	20642
Master's	20278
Matsui	20209, 20240, 20278, 20348
Matsushita	20035, 20162, 20226
Media Center PC	21972
Medion	20209, 20348, 20642
MEI	20035
Melectronic	20000, 20037, 20038
Memorex	20000, 20035, 20037, 20039, 20046, 20047, 20048, 20104, 20162, 20209, 20240, 20348, 20479, 21237
Memphis	20072
Metronic	20081
Metz	20037, 20081, 20162, 20226, 20347, 21562
MGA	20043, 20240
MGN Technology	20240
Micormay	20348
Micromaxx	20209, 20348
Microsoft	21972
Mind	21972
Minolta	20042
Mitsubishi	20000, 20041, 20043, 20048, 20067, 20081, 20642, 20807
Motorola	20035, 20048
MTC	20000, 20240
Multitec	20037
Multitech	20000, 20072, 20278
Murphy	20000
Myryad	20081
NAD	20104
Naiko	20642
National	20162, 20226, 20240
Nebula Electronics	20033
NEC	20035, 20037, 20038, 20041, 20048, 20067, 20104, 20209, 20278
Neckermann	20081
Nesco	20072
Neufunk	20209
Newave	20037
Nikkai	20072, 20278
Nikko	20037

Niveus Media	21972
Noblex	20240
Nokia	20041, 20042, 20046, 20048, 20081, 20104, 20240, 20278, 20315
Nordmende	20041, 20067, 20320
Northgate	21972
Novatronic	20209
Nu-Tec	20209
Oceanic	20000, 20041, 20046, 20048, 20081, 20104
Okano	20072, 20209, 20278, 20315, 20348
Olympus	20035, 20226
Onida	20162
Onimax	20642
Onkyo	20222
Optimus	20037, 20048, 20104, 20162, 20432, 21062
Orbit	20072
Orion	20002, 20121, 20184, 20209, 20348, 20479, 21479
Osaki	20000, 20037, 20072
Osume	20072
Otake	20209
Otto Versand	20081
Pacific	20000, 20348, 20642
Packard Bell	21972
Palladium	20037, 20041, 20072, 20209, 20315, 20348
Palsonic	20000, 20037, 20072, 20642
Panasonic	20035, 20162, 20225, 20226, 20614, 20616, 21035, 21062, 21308, 21562
Pathe Cinema	20043
Pathe Marconi	20041
Penney	20035, 20037, 20038, 20042, 20240, 21035, 21237
Pentax	20042
Perdio	20000, 20209
Philco	20000, 20035, 20038, 20072, 20209, 20226, 20479
Philips	20000, 20035, 20081, 20226, 20616, 20618, 20739
Phoenix	20278
Phonola	20081
Pilot	20037
Pioneer	20042, 20067, 20081, 20162, 21562
Polk Audio	20081
Portland	20278
Prinz	20000
Profitronic	20081, 20240
Proline	20000, 20278, 20320, 20642
Proscan	20060, 21060
Prosonic	20278
Protec	20072

Protech	20081, 20278
ProVision	20278
Pulsar	20039
Pye	20000, 20081
Qisheng	20060
Quarter	20046
Quartz	20046
Quasar	20035, 20162, 20278, 21035
Quelle	20081
Radialva	20037, 20048
Radiola	20081
Radionette	20037
RadioShack	20000, 20037
Radix	20037
Randex	20037
Rank	20041
Rank Arena	20041
RCA	20000, 20035, 20042, 20048, 20060, 20149, 20226, 20240, 20320, 20432, 20807, 20880, 21035, 21060
Realistic	20000, 20035, 20037, 20046, 20047, 20048, 20104
Reoc	20348
ReplayTV	20614, 20616
Rex	20041
RFT	20072
Ricavision	21972
Roadstar	20037, 20072, 20081, 20240, 20278
Royal	20072
Runco	20039
Saba	20041, 20067, 20278, 20320
Saisho	20209, 20348
Salora	20043, 20046, 20104
Sampo	20037, 20048
Samsung	20045, 20240, 20432, 20739, 21014
Sanky	20039, 20048
Sansui	20000, 20041, 20067, 20072, 20209, 20348, 20479, 21479
Sanyo	20046, 20047, 20048, 20067, 20104, 20159, 20209, 20240, 20348, 21330
Saville	20240, 20278
SBR	20081
Schaub Lorenz	20000, 20041, 20104, 20315, 20348
Schneider	20000, 20037, 20042, 20072, 20081, 20240, 20278, 20348, 20642
Scott	20043, 20045, 20121, 20184
Sears	20000, 20035, 20037, 20042, 20046, 20047, 20104, 21237
Seaway	20278
SEG	20072, 20081, 20240, 20278, 20642

SEI	20081
Seleco	20037, 20041
Semp	20045
Sentra	20072
Serie Dorada	20037
Sharp	20037, 20048, 20209, 20807
Shinco	20000
Shintom	20072, 20104
Shivaki	20037
Shogun	20240
Siemens	20037, 20046, 20081, 20104, 20320, 20347
Siera	20081
Silva	20037
Silver	20278
Singer	20045, 20072, 20348
Sinudyne	20081, 20209
Smaragd	20348
Sonic Blue	20614, 20616
Soniko	20072
Sonitron	20104
Sonneclair	20072
Sonolor	20046
Sontec	20037
Sonwa	20642
Sony	20000, 20032, 20033, 20035, 20636, 21232, 21295, 21972
Soundwave	20037, 20209, 20348
Ssangyong	20072
Stack 9	21972
Starlite	20037
Stern	20278
STS	20042
Sunkai	20209, 20278, 20348
Sunstar	20000
Suntronic	20000
Sunwood	20072
Supra	20037, 20240, 20278, 20348
Sylvania	20000, 20035, 20043, 20081, 21781
Symphonic	20000
Systemax	21972
T+A	20162
Tagar Systems	21972
Taisho	20209
Tandberg	20278
Tandy	20000, 20104
Tashiko	20000, 20037, 20048, 20081, 20240
Tatung	20000, 20041, 20043, 20045, 20048, 20067, 20081, 20209, 20348
Tchibo	20348
TCM	20348

Teac	20000, 20037, 20041, 20072, 20278, 20642
Tec	20072
Tech Line	20072
Technics	20035, 20081, 20162, 20226
TechniSat	20209
Teco	20035, 20037, 20038, 20041, 20048
Tedalex	20037, 20209, 20348, 20642
Teknika	20000, 20035, 20037
Teleavia	20041
Telefunken	20041, 20067, 20209, 20240, 20278, 20320, 20642
Telestari	20037
Teletech	20000, 20072, 20278
Tenosal	20072
Tensai	20000, 20072, 20278
Tevion	20209, 20348, 20642
Texet	20278
Thomas	20000
Thomson	20041, 20060, 20067, 20278, 20320
Thorn	20037, 20041, 20104
Tivo	20618, 20636, 20739, 21503
TMK	20240
Tokai	20037, 20072
Topline	20348
Toshiba	20041, 20042, 20043, 20045, 20067, 20081, 20209, 20432, 20845, 21008, 21145, 21289, 21323, 21503, 21972
Totevision	20037, 20240
Touch	21972
Towada	20072
Tradex	20081
Triad	20278
Uher	20240
Ultravox	20278
Unitech	20240
United	20348
Universal	20209
Universum	20000, 20037, 20081, 20104, 20209, 20240, 20315, 20348
Vector	20045
Vector Research	20038
Victor	20041, 20067, 21283
Video Concepts	20045
Video Technic	20000
Videomagic	20037
Videosonic	20240
Viewsonic	21972
Villain	20000
Voodoo	21972

Wards	20000, 20033, 20035, 20038, 20039, 20042, 20045, 20046, 20047, 20048, 20060, 20072, 20081, 20149, 20240
Watson	20081, 20642
Wharfedale	20642
White Westinghouse	20072, 20209, 20278
World	20348
XR-1000	20000, 20035, 20072
Yamaha	20038, 20041
Yamishi	20072, 20278
Yokan	20072
Yoko	20037, 20240
Yoshita	20072
Zenith	20000, 20033, 20039, 20209, 20479, 21479
ZT Group	21972
ZX	20209, 20348

TV

888	10264, 10412
A-Mark	10003
A.R. Systems	10374, 10455
Abex	10032
Accent	10009
Acura	10009
Addison	10092, 10108, 10653
Admiral	10087, 10093, 10163, 10264, 10363, 10463
Advent	10761, 10783, 10815, 10817, 10842
Adventura	10046
Adyson	10032, 10216, 10217
AEA	10037
AEG	10606
Agashi	10216, 10217
AGB	10516
Agef	10087
Aiko	10009, 10037, 10092, 10216, 10217, 10264
Aim	10045, 10208, 10264, 10339, 10374, 10412, 10455, 10606, 10706, 10753, 10805
Aiwa	10163, 10701, 10705, 10848
Akai	10009, 10030, 10035, 10037, 10060, 10072, 10163, 10178, 10191, 10208, 10216, 10217, 10218, 10264, 10361, 10363, 10371, 10377, 10412, 10433, 10473, 10480, 10516, 10548, 10556, 10581, 10602, 10606, 10631, 10648, 10672, 10696, 10698, 10702, 10706, 10714, 10715, 10729, 10745, 10753, 10812, 11537
Akashi	10009
Akiba	10037, 10218, 10282, 10455
Akira	10037, 10418, 10556

Akito	10037
Akura	10009, 10037, 10218, 10264, 10282, 10359, 10412, 10668, 10714, 11037
Alaron	10179, 10216
Alba	10009, 10036, 10037, 10163, 10216, 10218, 10235, 10247, 10355, 10371, 10418, 10443, 10487, 10581, 10668, 10714, 11037
Albatron	10700, 10843
Albiral	10102
Alfide	10672
Alkos	10035
Allorgan	10206, 10217
Allstar	10037
Ambassador	10177
America Action	10180
Amplivision	10217, 10370
Ampro	10751
Amstrad	10009, 10037, 10171, 10177, 10218, 10264, 10362, 10371, 10412, 10433, 10516, 10581, 10648, 11037
Anam	10003, 10009, 10180, 10250, 10628, 10700, 10861
Anam National	10055, 10250, 10650
Andersson	11163
Anex	10037, 10421
Anglo	10009, 10264
Anhua	10051
Anitech	10009, 10037, 10282
Ansonic	10009, 10104, 10247, 10292, 10370, 10428, 10556, 10668, 11437
AOC	10003, 10009, 10018, 10019, 10030, 10052, 10060, 10092, 10093, 10108, 10178, 10179, 10180, 10185, 10451, 10628
Aolingpu	10858
Aolinpike	10264, 10412
Apex	10156, 10765
Apex Digital	10748, 10765, 10767, 10879
Arcam	10216, 10217
Archer	10003
Ardem	10037, 10486, 10556, 10633, 10714, 10715
Aristona	10037, 10556
ART	11037
ASA	10070, 10087, 10104
Asberg	10102
Asora	10009
Astra	10037, 10264
Asuka	10217, 10218, 10264
ATD	10698
Atlantic	10001, 10206, 10320
Audinac	10180

Audiosonic	10009, 10037, 10109, 10217, 10218, 10264, 10337, 10370, 10374, 10428, 10486, 10714, 10715
Audioton	10217, 10264, 10428, 10486
Audiovox	10003, 10092, 10180, 10451, 10623, 10802, 10875
Autovox	10087, 10206, 10217, 10247, 10544
Aventura	10171
Awa	10009, 10011, 10036, 10037, 10108, 10157, 10216, 10217, 10264, 10374, 10412, 10512, 10606, 10698, 10785
Axxent	10009
Axxon	10714
Baihe	10009, 10264, 10412
Baile	10001, 10009, 10374, 10661
Baird	10072, 10073, 10193, 10208, 10217
Bang & Olufsen	10087, 10565
Baohuashi	10264, 10412
Baosheng	10009, 10817
Barco	10380
Basic Line	10009, 10037, 10217, 10218, 10282, 10339, 10374, 10455, 10556, 10668, 11037, 11163
Bauer	10805
Baur	10009, 10037, 10146, 10361, 10455, 10512, 10535, 10544
Baysonic	10180
Bazin	10217
Beaumark	10178
Beijing	10001, 10009, 10208, 10226, 10264, 10374, 10412, 10482, 10661, 10812, 10817, 10821
Beko	10037, 10292, 10370, 10418, 10428, 10486, 10606, 10714, 10715, 11037
Belcor	10019
Bell & Howell	10016, 10154
BenQ	11032, 11756
Beon	10032, 10037, 10418
Berthen	10668
Best	10337, 10370, 10421
Bestar	10037, 10370, 10374
Bestar-Daewoo	10374
Binatone	10217
Black Diamond	10556, 10587, 10614, 11037
Black Panther	10102
Black Strip	10035
Blaupunkt	10036, 10170, 10191, 10195, 10200, 10455, 10535
Blue Sky	10037, 10218, 10282, 10455, 10487, 10499, 10556, 10606, 10668, 10714, 10715, 11037, 11254, 11437
Blue Star	10282

Bondstec	10247
Boots	10009, 10217
Bosch	10320
Boxlight	10752, 10893
BPL	10037, 10208, 10282
Bradford	10180
Brandt	10109, 10287, 10335, 10560, 10625, 10714
Brandt Electronique	10335
Brinkmann	10037, 10418, 10486, 10668
Brionvega	10087, 10362
Britannia	10216, 10217
Brockwood	10019
Broksonic	10003, 10180, 10236, 10463
Bruns	10087
BTC	10218
Bush	10009, 10036, 10037, 10163, 10208, 10217, 10218, 10235, 10264, 10282, 10355, 10361, 10363, 10371, 10374, 10486, 10487, 10556, 10581, 10614, 10617, 10661, 10668, 10698, 10714, 11037
Caihong	10009, 10817
Cailing	10748
Caishi	10891
Candle	10030, 10046, 10056, 10186
Canton	10218
Carad	10037, 10610, 10668, 11037
Carena	10037, 10455
Carnivale	10030
Carrefour	10036, 10070
Carver	10054, 10170
Cascade	10009, 10037
Casio	10037, 10163
Cathay	10037
CCE	10037, 10217
Celebrity	10000
Celera	10765
Celestial	10767, 10819, 10820, 10821
Centrex	10698, 10780, 10826
Centrum	11037
Centurion	10037
Century	10087, 10238, 10247
CGE	10247, 10370, 10418
CGM	11037
Changcheng	10001, 10009, 10051, 10264, 10374, 10412, 10661, 10817
Changfei	10009, 10374, 10817
Changfeng	10264, 10412, 10696, 10753, 10817
Changhai	10009, 10817
Changhong	10009, 10156, 10264, 10508, 10765, 10767, 10783, 10817, 10820, 10821, 10848, 11156

Chengdu	10009, 10817
Ching Tai	10003, 10009, 10092, 10179
Chun Yun	10000, 10003, 10009, 10092, 10179, 10180, 10700, 10843
Chunfeng	10009, 10264
Chung Hsin	10036, 10053, 10108, 10180
Chungfeng	10412
Chunsun	10009, 10817
Cimline	10009, 10218
Cinema	10672
Cineral	10092, 10451
Citizen	10030, 10039, 10046, 10056, 10060, 10092, 10186, 10280
City	10009
Clairtone	10185
Clarion	10180
Clarivox	10037, 10070, 10337
Clatronic	10009, 10037, 10102, 10217, 10218, 10247, 10264, 10320, 10370, 10371, 10556, 10579, 10606, 10648, 10714
Clayton	11037
CMS	10216
CMS Hightec	10217
Commercial Solutions	10047, 11447
Concerto	10056
Condor	10009, 10037, 10163, 10247, 10264, 10282, 10320, 10370, 10411, 10418
Conia	10754, 10821
Conic	10032
Conrac	10808
Conrowa	10009, 10145, 10156, 10264, 10412, 10696, 10698, 10753, 11156, 11170
Contec	10009, 10036, 10037, 10157, 10180, 10185, 10216, 10264, 10698
Continental Edison	10109, 10287, 10487
Cosmel	10037, 10337
Craig	10180
Crosley	10054, 10087, 10247
Crown	10009, 10037, 10039, 10053, 10180, 10208, 10339, 10359, 10370, 10412, 10418, 10421, 10486, 10487, 10579, 10606, 10672, 10712, 10714, 10715
Crown Mustang	10672
CS Electronics	10216, 10218, 10247
CTC	10247
Curtis Mathes	10016, 10030, 10039, 10047, 10051, 10054, 10056, 10060, 10093, 10145, 10154, 10166, 10451, 10466, 10702, 11147, 11347
CXC	10180
Cybertron	10218

D-Vision	10037, 10556
D.Boss	10037
Daewoo	10003, 10009, 10019, 10030, 10032, 10037, 10039, 10056, 10092, 10108, 10154, 10170, 10178, 10180, 10217, 10218, 10264, 10374, 10451, 10499, 10556, 10623, 10628, 10634, 10661, 10672, 10700, 10706, 10865, 10880, 11661
Dainichi	10216, 10218
Dansai	10009, 10032, 10035, 10036, 10037, 10208, 10216
Dansette	10412
Dantax	10606, 10714, 10715
Datsura	10208
Dawa	10009
Daytek	10037, 10706
Dayton	10009
Daytron	10019, 10374
Dayu	10374, 10661
De Graaf	10208, 10363, 10548
DEC	10418, 10556, 10698, 10785, 10795
Decca	10037, 10072, 10217, 10516, 10621
Deitron	10037, 10374
Dell	11080, 11178, 11264, 11454
Denko	10264
Denon	10145, 10511, 10576
Denstar	10628
Denver	10037, 10587, 10606
DER	10193
Desmet	10009, 10037, 10087, 10320
Diamant	10037
Diamond	10009, 10037, 10216, 10264, 10371, 10672, 10698, 10706, 10825
Dick Smith Electronics	10698
Digatron	10037
Digiline	10105, 10668
Digital Life	10780, 10872, 10891
Digitex	10820
Digitor	10037, 10499, 10698, 11724
Digix	10880
DiK	10037
Dixi	10009, 10037, 10087
DL	10037, 10780, 10848, 10872, 10891
Domeos	10037, 10668, 11037
Domland	10394
Dongda	10009
Donghai	10009
Dream Vision	11704
DSE	10698

Dual	10037, 10217, 10259, 10394, 10531, 10544, 11137
Dual Tec	10217
Dumont	10017, 10019, 10070, 10087, 10102
Dunai	10544
Durabrand	10003, 10171, 10178, 10180, 10463, 11034, 11463
DVX	10891
Dwin	10720, 10774
Dynatron	10012, 10037
E-Elite	10218
Ecco	10706, 10773
ECE	10037
Edison-Minerva	10487
Elbe	10217, 10238, 10259, 10292, 10361, 10362, 10411, 10435, 10516, 10610, 10630
Elbe-Sharp	10516
Electroband	10000, 10185
Electrograph	11755
Electrohome	10381
Elekta	10009, 10037, 10264, 10282
Elektra	10017, 11661
Elin	10009, 10037, 10104, 10163, 10361, 10548
Elite	10218, 10320
Elman	10102
Elta	10009, 10264
Emco	10247
Emerson	10019, 10037, 10038, 10039, 10070, 10087, 10154, 10163, 10171, 10177, 10178, 10179, 10180, 10185, 10236, 10247, 10280, 10282, 10320, 10361, 10370, 10371, 10463, 10486, 10623, 10714
Emperor	10282
Envision	10030, 10813
Enzer	10753
Epson	10833, 10840
Erres	10012, 10037
ESA	10171, 10812
ESC	10037, 10217
Ether	10003, 10009, 10030
Etron	10001, 10009
Eurofeel	10217, 10264
EuroLine	10556
Euroman	10037, 10216, 10217, 10264, 10421
Europa	10037
Europhon	10102, 10163, 10217, 10516
Evolution	11756
Expert	10206
Exquisit	10037, 10247
Fagor	10037

Feilang	10009
Feilu	10009, 10817
Feiyan	10264, 10412
Feiyue	10009, 10817
Fenner	10009, 10374
Ferguson	10037, 10053, 10073, 10109, 10193, 10238, 10287, 10335, 10443, 10548, 10560, 10625
Fidelity	10037, 10163, 10171, 10193, 10216, 10264, 10361, 10363, 10371, 10412, 10512, 10531, 10544
Filsai	10217
Finlandia	10045, 10072, 10163, 10208, 10287, 10346, 10359, 10363, 10548
Finlux	10037, 10070, 10072, 10087, 10102, 10104, 10105, 10179, 10217, 10346, 10411, 10473, 10480, 10492, 10516, 10556, 10606, 10621, 10629, 10631, 10714, 10715, 10808
Firstar	10009, 10236
Firstline	10009, 10037, 10072, 10163, 10208, 10216, 10217, 10235, 10238, 10247, 10321, 10361, 10374, 10411, 10531, 10544, 10556, 10587, 10668, 10714, 10808, 11037
Fisher	10036, 10045, 10047, 10072, 10087, 10104, 10154, 10157, 10159, 10208, 10217, 10370, 10544, 10555
Flint	10037, 10072, 10218, 10264, 10455, 10610
Forgestone	10193
Formenti	10037, 10087, 10216, 10320
Formenti-Phoenix	10216, 10320
Fortress	10093
Fraba	10037, 10370
Friac	10009, 10037, 10102, 10370, 10421, 10499, 10610
Frontech	10009, 10163, 10217, 10247, 10264, 10363
Fujitsu	10009, 10037, 10072, 10163, 10179, 10186, 10206, 10217, 10259, 10361, 10683, 10809, 10853
Fujitsu General	10009, 10163, 10206, 10217, 10683
Funai	10171, 10179, 10180, 10264, 10412, 10556, 10668, 11977
Furi	10145, 10264, 10412, 10817
Futronic	10264, 10795
Future	10037
Futuretech	10180
Galaxi	10037, 10361
Galaxis	10037, 10370
Ganxin	10817
Gateway	11755, 11756
GBC	10009, 10218, 10374

GE	10021, 10027, 10030, 10047, 10051, 10055, 10092, 10093, 10109, 10135, 10178, 10180, 10282, 10287, 10335, 10451, 10560, 10625, 11147, 11347, 11447, 11454
GEC	10037, 10072, 10163, 10217, 10361, 10516
Geloso	10009, 10363, 10374
General	10186, 10590
General Technic	10009
Genesis	10009, 10037
Genexxa	10009, 10163, 10218
Gericom	10808, 10865
Giant	10217
Gibraltar	10017, 10019, 10030
Gintai	10721
Go Video	10886
Goldfunk	10668
GoldHand	10216
GoldStar	10001, 10019, 10030, 10032, 10037, 10039, 10056, 10109, 10154, 10163, 10178, 10216, 10217, 10247, 10290, 10361, 10363, 10377, 10455, 10556, 10606, 10714, 10715
Gooding	10487
Goodmans	10009, 10032, 10035, 10036, 10037, 10072, 10179, 10217, 10218, 10235, 10264, 10335, 10360, 10371, 10374, 10451, 10480, 10487, 10499, 10516, 10556, 10560, 10579, 10630, 10634, 10661, 10668, 10714, 10808, 11037, 11163
Gorenje	10037, 10370, 10421
GPM	10218
Gradiente	10053, 10056, 10170
Graetz	10037, 10163, 10339, 10361, 10371, 10487, 10714
Gran Prix	10648
Granada	10037, 10045, 10072, 10108, 10146, 10163, 10208, 10217, 10226, 10339, 10356, 10359, 10363, 10473, 10516, 10548, 10560
Grandin	10009, 10037, 10163, 10282, 10320, 10374, 10455, 10579, 10610, 10668, 10714, 10715, 11037
Gronic	10163
Grundig	10036, 10037, 10070, 10191, 10195, 10370, 10443, 10487, 10535, 10556, 10587, 10630, 10672, 10706
Grunpy	10179, 10180
H&B	10808
Haaz	10706
Haier	10037, 10264, 10508, 10587, 10698, 10768, 10779, 10869, 10891, 11034
Haihong	10009

Haiyan	10264, 10412, 10817
Halifax	10217
Hallmark	10178
Hammerstein	10060, 10264
Hampton	10216, 10217
Hanimex	10218
Hankook	10019, 10030, 10056, 10178, 10180, 10628
Hanseatic	10009, 10037, 10087, 10195, 10217, 10282, 10320, 10361, 10377, 10394, 10428, 10499, 10544, 10556, 10634, 10661, 10714, 10808, 11137
Hantarex	10009, 10037, 10102, 10238, 10516, 10865
Hantor	10037
Harley Davidson	10179
Harman/Kardon	10054
Harsper	10865
Harvard	10180
Harwa	10773
Harwood	10009, 10032, 10037, 10412, 10487
Havermy	10093
HCM	10009, 10037, 10217, 10218, 10264, 10282, 10412, 10418, 10606
Helios	10865
Hello Kitty	10451
Hema	10009, 10217
Hemmermann	10544
Hher	10714
Higashi	10216
Hikona	10218
Himitsu	10180, 10628, 10779
Hinari	10009, 10036, 10037, 10179, 10218, 10235, 10264, 10355
Hisawa	10218, 10282, 10455, 10610, 10714
Hisense	10009, 10037, 10145, 10156, 10208, 10264, 10508, 10512, 10556, 10696, 10706, 10748, 10753, 10780, 10821, 10848, 11156, 11170
Hit	10087
Hitachi	10009, 10016, 10019, 10027, 10030, 10032, 10036, 10037, 10038, 10039, 10044, 10056, 10072, 10092, 10105, 10108, 10109, 10145, 10151, 10156, 10157, 10163, 10165, 10178, 10179, 10186, 10194, 10217, 10356, 10359, 10361, 10363, 10381, 10473, 10480, 10481, 10492, 10499, 10508, 10512, 10516, 10548, 10576, 10578, 10629, 10634, 10719, 10744, 10884, 11037, 11045, 11137, *[11145] , 11156, 11170, 11225, 11256, 11481, 11576
Hitachi Fujian	10037, 10108, 10145, 10150, 10499, 10828
Hitsu	10009, 10218, 10455, 10610
HMV	10087, 10193

Home Electronics	10606
Hongmei	10009, 10093, 10264, 10817, 10848
Hongyan	10264, 10412, 10817
Hornophon	10012, 10037
Hoshai	10282
Hua Tun	10009
Huafa	10009, 10145
Huanghaimei	10009
Huanghe	10009, 10817
Huanglong	10009
Huangshan	10009, 10264, 10412, 10817
Huanyu	10216, 10264, 10374, 10817, 10848
Huaqiang	10264, 10412
Huari	10145, 10264, 10412
Huodateji	10051
Hyper	10009, 10216, 10217, 10247
Hypson	10037, 10264, 10282, 10411, 10455, 10621, 10668, 10714, 10715, 11037
Hyundai	10037, 10698, 10706, 10753, 10849, 10865
Iberia	10037
ICE	10216, 10217, 10218, 10264, 10371, 10556
ICeS	10216, 10218
Imperial	10037, 10163, 10247, 10361, 10370, 10418, 10630
Imperial Crown	10001, 10009, 10264, 10374, 10412, 10661
Indiana	10037
Infinity	10054
InFocus	10752
Ingelen	10163, 10361, 10487, 10610, 10714
Ingersoll	10009
Inno Hit	10009, 10037, 10072, 10102, 10217, 10247, 10282, 10290, 10516
Innova	10037
Innowert	10865
Inteq	10017
Interbuy	10037, 10247, 10264, 10512
Interfunk	10012, 10037, 10087, 10163, 10200, 10247, 10275, 10361, 10512
Internal	10037
Intervision	10009, 10037, 10102, 10163, 10217, 10218, 10247, 10264, 10282, 10370, 10377, 10394, 10455, 10486, 10487
IR	10011, 10012, 10032, 10035, 10036, 10037, 10045, 10070, 10072, 10073, 10087, 10093, 10102, 10104, 10105, 10108, 10109, 10146, 10157, 10163, 10191, 10193, 10194, 10195, 10200, 10206, 10216, 10217, 10226, 10235, 10238, 10247, 10287, 10290, 10291, 10292, 10320, 10356, 10359, 10361, 10363, 10370, 10374, 10512, 10516, 10535, 10556

Irradio	10218, 10247, 10290, 10371
IRT	10451, 10628, 10698, 11661
Isukai	10037, 10218, 10282, 10455
ITC	10217, 10320
ITS	10216, 10264, 10371
ITT	10163, 10179, 10193, 10208, 10339, 10346, 10361, 10473, 10480, 10544, 10548, 10610
ITT Nokia	10163, 10179, 10208, 10339, 10346, 10361, 10363, 10473, 10480, 10548, 10606, 10610
ITV	10037, 10264, 10374
Janeil	10046
JBL	10054
JCB	10000
Jean	10003, 10009, 10036, 10051, 10092, 10156, 10179, 10236, 10721
Jensen	10698, 10706, 10761, 10815, 10817
Jiahua	10051
JiaLiCai	10009, 10264, 10412
Jinfeng	10051, 10208, 10226, 10817
Jinhai	10848
Jinque	10009, 10264, 10412, 10817
Jinta	10009, 10264, 10412, 10848
Jinxing	10009, 10037, 10054, 10145, 10156, 10264, 10556, 10698, 10817, 10821
JMB	10443, 10499, 10556, 10634
JNL	10698
Jocel	10712
Jubilee	10556
Juhua	10264, 10412, 10817
JVC	10036, 10053, 10093, 10193, 10218, 10371, 10418, 10463, 10508, 10576, 10606, 10653, 10683, 10731, 11253
Kaige	10009, 10264, 10412, 10817
Kaisui	10009, 10037, 10216, 10217, 10218, 10282, 10455
Kambrook	10217, 10264, 10556
Kamp	10216
Kangchong	10848
Kangli	10001, 10009, 10264, 10374, 10661, 10817
Kangyi	10009, 10264, 10412
Kapsch	10104, 10163, 10206, 10361
Karcher	10037, 10163, 10264, 10282, 10421, 10606, 10610, 10714
Kathrein	10556
Kawa	10371
Kawasho	10216
Kaypani	10052
KB Aristocrat	10163
KEC	10180

Kendo	10037, 10102, 10235, 10247, 10362, 10411, 10428, 10512, 10610, 11437
Kennedy	10206, 10435
Kennex	11037
Kenwood	10019, 10030
KIC	10217
Kingsley	10216
Kiota	10001, 10371, 10455
Kioto	10054, 10556, 10706, 10785
Kiton	10037, 10668
KLH	10765, 10767
KLL	10037
Kloss	10024, 10046
Kneissel	10037, 10238, 10259, 10292, 10362, 10374, 10411, 10435, 10499, 10556, 10610
Kolin	10036, 10053, 10108, 10150, 10180
Kolster	10102, 10247
Kongque	10009, 10264, 10817
Konichi	10009
Konka	10037, 10218, 10282, 10371, 10418, 10587, 10628, 10632, 10638, 10641, 10703, 10707, 10714, 10725, 10726, 10754, 10779, 10795, 10816, 10817
Kontakt	10487
Korpel	10037
Korting	10087, 10320, 10421
Kotron	10264
Koyoda	10009
Kraking	10238
Kriesler	10012
KTV	10030, 10039, 10180, 10185, 10217, 10280
Kuaile	10009, 10264, 10412
Kulun	10009
Kunlun	10051, 10208, 10226, 10264, 10374, 10661, 10817
Kyoshu	10032, 10264, 10412, 10418
Kyoto	10032, 10163, 10216, 10217
L&S Electronic	10714, 10808
LaSAT	10486
Leader	10009
Lecson	10037
Legend	10009
Lemair	10032, 10411
Lenco	10037, 10163, 10374, 10721, 11037
Levis Austria	10037
Leyco	10037, 10072, 10264, 10579

LG	10001, 10003, 10019, 10030, 10032, 10037, 10038, 10039, 10056, 10060, 10108, 10178, 10442, 10556, 10606, 10644, 10698, 10700, 10714, 10715, 10856, 11148, 11178, 11265, 11637, 10033
Liesenk & Tter	10037
Liesenkotter	10012, 10037
Lifetec	10037, 10218, 10264, 10374, 10668, 10714, 11037, 11137, 11437
Lihua	10817
Lloyd's	10001, 10009, 10264
Lloytron	10032
Loewe	10037, 10087, 10136, 10292, 10362, 10512, 10516, 10633, 10655
Logik	10001, 10009, 10011, 10016, 10060, 10193, 10264, 10418, 10698, 10706, 10773, 10880
Logix	10668
Longjiang	10264, 10412, 10817
Luma	10206, 10259, 10362, 10363, 11037
Lumatron	10217, 10361
Lux May	10009, 10037, 10556, 10581
Luxman	10056, 10412, 10579
Luxor	10163, 10179, 10194, 10208, 10217, 10290, 10356, 10361, 10363, 10473, 10480, 10548, 10631, 11037, 11163
LXI	10047, 10054, 10154, 10156, 10178
M & S	10054
M Electronic	10009, 10037, 10104, 10105, 10109, 10163, 10217, 10287, 10346, 10374, 10480
Madison	10037
Magnadyne	10087, 10102, 10247, 10516, 10544
Magnafon	10102, 10216, 10516
Magnavox	10020, 10024, 10030, 10036, 10037, 10054, 10096, 10179, 10186, 10187, 10386, 10706, 10729, 10780, 10802, 11254, 11454
Magnum	10037, 10606, 10648, 10714, 10715
Majestic	10016
Manesth	10035, 10037, 10163, 10217, 10235, 10264, 10320, 10361
Manhattan	10037, 10163, 10668, 11037
Marantz	10030, 10037, 10054, 10412, 10556, 10704, 10854, 10855, 11154
Marelli	10087
Mark	10037, 10217, 10486, 10714, 10715
Master's	10499
Masuda	10009, 10037, 10217, 10218, 10264, 10371
Materin	10208, 10858

Matsui	10009, 10011, 10035, 10036, 10037, 10072, 10163, 10177, 10191, 10195, 10208, 10217, 10235, 10335, 10355, 10363, 10371, 10433, 10443, 10455, 10487, 10516, 10544, 10556, 10579, 10629, 10714, 11037
Matsushita	10051, 10250, 10650
Matsuiama	10587
Maxam	10264
Maxdorf	10773
Maxent	11755
MCE	10009
Mediator	10012, 10037
Medion	10037, 10512, 10556, 10668, 10698, 10714, 10808, 10880, 11037, 11137, 11437
Megapower	10700
Megas	10610
Megatron	10003, 10145, 10178
MEI	10185, 11037
Meile	10264, 10412, 10817, 10848
Melectronic	10009, 10037, 10104, 10105, 10163, 10191, 10195, 10216, 10217, 10247, 10346, 10361, 10374, 10411, 10480, 10492, 10512, 10634, 10661, 10714
Memorex	10009, 10016, 10056, 10060, 10150, 10154, 10178, 10179, 10250, 10463, 11037
Memphis	10337
Mercury	10001, 10009, 10060, 10264, 10473, 10556, 10706
Mermaid	10037
Merritt	10163
Metronic	10625
Metz	10037, 10070, 10087, 10275, 10367, 10388, 10447, 10535, 10587, 10668, 10746
MGA	10019, 10030, 10037, 10150, 10178, 10218, 10374
Micromaxx	10037, 10630, 10668, 10808, 11037
Microstar	10808
MicroTEK	10706
Midland	10017, 10032, 10039, 10047, 10051, 10135
Minato	10037
Minerva	10070, 10108, 10487, 10516, 10535
Minoka	10359, 10412
Minutz	10021
Mistral Electronics	10193
Mitsubishi	10019, 10030, 10036, 10037, 10056, 10087, 10093, 10108, 10150, 10154, 10178, 10179, 10180, 10208, 10236, 10250, 10381, 10512, 10535, 10556, 10817, 10836, 10868, 11037, 11250
Mitsuri General	10163

Mivar	10216, 10217, 10290, 10291, 10292, 10370, 10516, 10609
Monaco	10009
Monivision	10700, 10843
Morgan's	10037
Motorola	10055, 10093
MTC	10019, 10030, 10056, 10060, 10163, 10185, 10216, 10361, 10370, 10512
MTEC	10032
MTlogic	10714
Mudan	10009, 10051, 10208, 10226, 10264, 10412, 10817
Multibroadcast	10193
Multitec	10037, 10486, 10668, 11037
Multitech	10009, 10037, 10102, 10180, 10216, 10217, 10247, 10264, 10363, 10486, 10556
Murphy	10039, 10163, 10216
Musikland	10037, 10218, 10247
Myryad	10556
NAD	10156, 10178, 10361, 10866
Naiko	10037, 10606
Nanbao	10009, 10264, 10412, 10848
Nansheng	10264, 10412, 10817
Naonis	10363
NAT	10226
National	10051, 10055, 10208, 10226, 10508
NEC	10009, 10011, 10019, 10030, 10036, 10046, 10051, 10053, 10056, 10154, 10156, 10165, 10170, 10178, 10186, 10217, 10264, 10320, 10374, 10381, 10412, 10455, 10497, 10499, 10508, 10603, 10661, 10704, 10705, 10817, 10882, 11170, 11270, 11704
Neckermann	10037, 10087, 10163, 10191, 10200, 10247, 10320, 10363, 10370, 10411, 10418, 10512, 10556
NEI	10037, 10163, 10287, 10337, 10371
Neovia	10865
Nesco	10179, 10247
Netsat	10037
NetTV	11755
Network	10032, 10337
Neufunk	10037, 10218, 10556, 10610, 10714
New Tech	10217
Newave	10009, 10092, 10093, 10178, 10721
Nicam	10544
Nicamagic	10216
Nikkai	10009, 10032, 10035, 10036, 10037, 10072, 10216, 10217, 10218, 10264, 10337
Nikko	10030, 10092, 10178
Nikon	10848

Noblex	10154, 10180
Nobliko	10070, 10102, 10216
Nokia	10109, 10163, 10179, 10208, 10320, 10339, 10346, 10359, 10361, 10374, 10473, 10480, 10548, 10606, 10610, 10631
Norcent	10748, 10824
Nordic	10217
Nordmende	10037, 10109, 10163, 10195, 10287, 10335, 10560, 10714
Norfolk	10163
Normerel	10037
Noshi	10018
Novak	10012, 10037
Novatronic	10037, 10105, 10374, 10531
NTC	10092
Nu-Tec	10037, 10455, 10698, 10706, 10820
Oceanic	10163, 10208, 10361, 10473, 10548
Okano	10009, 10037, 10370
Omega	10264
Omni	10264, 10698, 10706, 10780, 10826, 10872, 10891
On Command	10531
Onimax	10714
Onking	10280
Onwa	10102, 10180, 10218, 10371, 10433, 10581, 10602
Optimus	10154, 10166, 10250, 10650
Optoma	10887
Optonica	10093, 10165
Orion	10011, 10037, 10177, 10179, 10235, 10236, 10264, 10320, 10321, 10355, 10412, 10443, 10463, 10516, 10531, 10544, 10556, 10606, 10655, 10714, 10880, 11463
Orline	10037, 10218
Ormond	10668, 11037
Orsowe	10516
Osaki	10032, 10037, 10072, 10217, 10218, 10264, 10355, 10374, 10412, 10556
Osio	10290
Oso	10218
Osume	10032, 10036, 10037, 10072, 10157, 10218
Otto Versand	10036, 10037, 10093, 10109, 10191, 10217, 10226, 10235, 10247, 10320, 10361, 10512, 10535, 10544, 10556
Pacific	10037, 10556, 10714, 11037, 11137
Pael	10216
Palladium	10037, 10247, 10363, 10370, 10411, 10418, 10630, 10655, 10714, 11137
Palsonic	10001, 10037, 10217, 10218, 10264, 10377, 10412, 10418, 10698, 10773, 10779

Panama	10037, 10217, 10247, 10264
Panashiba	10001
Panasonic	10037, 10051, 10054, 10055, 10108, 10163, 10208, 10226, 10250, 10361, 10367, 10508, 10516, 10548, 10650, 10853, 11310, 11410, 11650
Panavision	10037, 10411
Panda	10009, 10051, 10208, 10226, 10264, 10412, 10508, 10698, 10706, 10780, 10817, 10821, 10826, 10848, 10891
Pathe Cinema	10163, 10216, 10238, 10320, 10370
Pausa	10009
Peng Sheng	10891
Penney	10003, 10018, 10019, 10021, 10027, 10030, 10032, 10039, 10047, 10051, 10056, 10060, 10135, 10156, 10178, 11347
Perdio	10037, 10072, 10163, 10216, 10282, 10320
Phase	10032
Philco	10019, 10020, 10030, 10032, 10037, 10054, 10056, 10087, 10092, 10096, 10145, 10178, 10180, 10186, 10247, 10370, 10418, 10451, 10463, 10628, 10774, 11661
Philex	10193, 10548
Philips	10000, 10009, 10012, 10017, 10019, 10020, 10024, 10027, 10030, 10032, 10037, 10051, 10054, 10056, 10080, 10087, 10092, 10108, 10178, 10186, 10187, 10191, 10193, 10200, 10238, 10361, 10374, 10423, 10556, 10690, 10721, 10772, 10774, 11154, 11454, 11756
Phoenix	10037, 10087, 10216, 10320, 10486
Phonola	10012, 10037, 10080, 10087, 10193, 10216
Pilot	10019, 10030, 10037, 10039, 10706, 10712
Pioneer	10011, 10037, 10038, 10109, 10163, 10166, 10170, 10287, 10361, 10423, 10428, 10486, 10512, 10679, 10760, 10866
Pionier	10486
Plantron	10009
Playsonic	10037, 10217, 10339, 10714, 10715
Polaroid	10765, 10865
Polytron	10282, 10697
Polyvision	10697
Portland	10019, 10039, 10092, 10374
Powerpoint	10037, 10487
Prandoni-Prince	10361, 10363, 10516
Premier	10037, 10264
Prima	10009, 10264, 10412, 10761, 10783, 10815, 10817
Princess	10698
Princeton	10700, 10717
Prinston	11037

Prinz	10194, 10361, 10544
Prism	10051
Profex	10009, 10163, 10361, 10363, 10370
Profex Fidelity	10102
Profi	10009
Profitronic	10037, 10102
Proline	10037, 10072, 10321, 10411, 10556, 10621, 10625, 10630, 10634
Proscan	10047, 11347, 11447
Prosonic	10037, 10217, 10451, 10579, 10668, 10714
Protech	10009, 10037, 10102, 10163, 10180, 10217, 10247, 10264, 10337, 10418, 10486, 10668, 11037
Proton	10001, 10003, 10009, 10030, 10039, 10052, 10056, 10178, 10466, 10644
ProVision	10037, 10556, 10714
Pulsar	10017, 10019
Pye	10012, 10037, 10087, 10193, 10374, 10412, 10556
Qingdao	10051, 10208, 10226, 10264, 10412, 10817
Quadral	10218, 10418
Qualcraft	10039
Quasar	10009, 10051, 10055, 10165, 10247, 10250, 10650, 10865
Quelle	10011, 10037, 10070, 10104, 10200, 10361, 10512, 10535, 10544, 10668, 11037
Questa	10032, 10036
R-Line	10037, 10163
Radialva	10218, 10337
Radiola	10012, 10037, 10217, 10556
Radiomarelli	10037, 10087, 10516
RadioShack	10019, 10030, 10032, 10037, 10039, 10047, 10056, 10154, 10165, 10178, 10180
Radiotone	10009, 10037, 10264, 10412, 10428, 10579, 10648, 10668, 11037
Rank Arena	10036, 10157, 10602, 10753
RBM	10070
RCA	10000, 10018, 10019, 10030, 10038, 10047, 10051, 10060, 10090, 10092, 10093, 10135, 10178, 10560, 10618, 10625, 10679, 10753, 11047, 11147, 11247, 11347, 11447, 11454, 11547
Realistic	10019, 10030, 10032, 10039, 10056, 10154, 10165, 10178, 10180
Recor	10037, 10264, 10418
Rediffusion	10036, 10346, 10361, 10548
Reflex	10037, 10668, 11037
Relisys	10865
Reoc	10714
Revox	10037

Rex	10163, 10206, 10259, 10264, 10363, 10411
RFT	10037, 10072, 10087, 10264, 10370, 10428
Rhapsody	10185, 10216
Ricoh	10037
Rinex	10264, 10418, 10698, 10773
Roadstar	10009, 10037, 10218, 10264, 10282, 10418, 10668, 10714, 11037
Robotron	10087
Rover	10036
Rowa	10009, 10037, 10216, 10217, 10264, 10556, 10587, 10698, 10712, 10748, 10817
Rownsonic	10163
Royal	10418, 10825
Royal Lux	10335, 10412
Runco	10017, 10030, 10497, 10603
Ruyi	10817
Saba	10087, 10109, 10163, 10250, 10287, 10335, 10361, 10498, 10516, 10548, 10560, 10625, 10714
Saccs	10238
Sagem	10455, 10610
Saige	10009, 10817
Saisho	10009, 10011, 10177, 10217, 10235, 10264, 10374, 10516, 10544, 10556
Saivod	10037, 10668, 10712, 11037
Saka	10163
Sakyno	10455
Salora	10163, 10194, 10208, 10290, 10356, 10359, 10361, 10363, 10473, 10480, 10516, 10548, 10606, 10621, 10631
Salsa	10335
Sambers	10102, 10516
Sampo	10009, 10030, 10032, 10036, 10039, 10052, 10092, 10093, 10154, 10171, 10178, 10650, 10700, 10721, 11755
Samsung	10009, 10019, 10030, 10032, 10037, 10039, 10056, 10060, 10072, 10090, 10092, 10093, 10154, 10156, 10163, 10178, 10179, 10195, 10208, 10216, 10217, 10226, 10264, 10290, 10370, 10482, 10556, 10587, 10618, 10644, 10682, 10702, 10718, 10766, 10774, 10812, 10814, 10817, 10821, 11060
Samsux	10039
Sandra	10216, 10217
Sanjian	10264, 10412
Sansei	10451
Sansui	10037, 10264, 10371, 10412, 10455, 10463, 10587, 10602, 10655, 10698, 10706, 10714, 10727, 10729, 10861, 11537
Santon	10009

Sanyo	10011, 10036, 10045, 10072, 10088, 10104, 10108, 10145, 10146, 10154, 10156, 10157, 10159, 10180, 10208, 10216, 10217, 10264, 10280, 10339, 10370, 10381, 10412, 10486, 10508, 10544, 10555, 10556, 10721, 10799, 10893, 11154
Sanyuan	10009, 10093, 10817
SBR	10012, 10037, 10193, 10556
Schaub Lorenz	10037, 10361, 10374, 10486, 10548, 10606, 10714
Schneider	10012, 10037, 10070, 10163, 10217, 10218, 10247, 10259, 10361, 10371, 10394, 10544, 10556, 10648, 10668, 10714, 11037, 11137
Scimitsu	10019
Scotch	10178
Scotland	10163
Scott	10019, 10178, 10179, 10180, 10236
Sears	10047, 10054, 10056, 10146, 10154, 10156, 10159, 10171, 10178, 10179
Seaway	10556, 10634
Seelver	11037
SEG	10009, 10036, 10037, 10102, 10163, 10216, 10217, 10218, 10264, 10362, 10487, 10634, 10668, 11037, 11163, 11437
SEI	10087, 10102, 10177, 10206, 10516, 10544
Sei-Sinudyne	10037, 10087, 10102, 10206, 10516, 10544
Seleco	10163, 10206, 10259, 10264, 10346, 10362, 10363, 10371, 10411, 10435
Semivox	10180
Semp	10156, 11356
Sencora	10009
Sentra	10035
Serino	10093, 10455, 10610
Shancha	10264, 10412, 10817
Shanghai	10009, 10208, 10226, 10264, 10412, 10817, 10848
Shaofeng	10145, 10817
Sharp	10009, 10030, 10032, 10036, 10039, 10053, 10093, 10157, 10165, 10193, 10200, 10256, 10386, 10491, 10516, 10650, 10688, 10689, 10720, 10818, 10851, 11193
Shen Ying	10003, 10009, 10092, 10179
Shencai	10009, 10145, 10264, 10412
Sheng Chia	10009, 10093, 10179, 10236
Shenyang	10009, 10264, 10696, 10753, 10817
Sherwood	10009
Shintoshi	10037
Shivaki	10037, 10178, 10374, 10443, 10451
Shogun	10019
Shorai	10179

Show	10009, 10072, 10418, 10706
Siarem	10087, 10102, 10516
Siemens	10032, 10037, 10146, 10157, 10191, 10195, 10200, 10361, 10535
Siera	10012
Siesta	10370
Signature	10016
Silva	10037, 10216, 10361, 10648
Silva Schneider	10037
Silver	10036, 10037, 10179, 10361, 10455, 10715
SilverCrest	11037
Simpson	10186, 10187
Singer	10009, 10087, 10102, 10163, 10335, 10362, 10371, 10433, 10435, 10548, 10698, 10706, 11537
Sinotec	10264, 10418, 10706, 10773
Sinudyne	10087, 10102, 10177, 10206, 10235, 10516, 10544
Skantic	10356
SKY	10037, 10282
Skygiant	10180
Skysonic	10696, 10753
Skyworth	10009, 10037, 10264, 10696, 10698, 10727, 10748, 10753, 10805, 10817, 10825
Sliding	10865
SLX	10512, 10668
Smaragd	10487
Soemtron	10865
Solavox	10032, 10037, 10072, 10163, 10361, 10548
Sole	10813
Sonawa	10218
Songba	10009
Soniko	10037
Sonitron	10208, 10217, 10339, 10370
Sonoko	10009, 10037, 10282
Sonor	10163, 10208, 10282, 10361, 10548
Sontec	10009, 10037, 10370
Sony	10000, 10011, 10036, 10037, 10053, 10080, 10093, 10102, 10111, 10145, 10150, 10156, 10157, 10170, 10250, 10353, 10650, 10834, 11100, 11505, 11651
Sound & Vision	10102, 10374
Soundesign	10178, 10179, 10180, 10186
Soundwave	10032, 10037, 10320, 10418, 10715
Sowa	10036, 10051, 10060, 10092, 10156, 10178, 10226
Spectra	10009
Spectricon	10003
Squareview	10171
Ssangyong	10009, 10032

SSS	10019, 10180
Stag	10032
Staksonic	10009
Standard	10009, 10037, 10217, 10218, 10320, 10374, 11037
Starlite	10009, 10037, 10180, 10264
Stenway	10218, 10282
Stern	10163, 10206, 10259, 10363, 10411
Strato	10009, 10037, 10264
Studio Experience	10843
Sunic Line	10037
Sunkai	10037, 10321, 10355, 10455, 10487, 10531, 10610
Sunstar	10009, 10037, 10264, 10371, 10579
Sunwood	10037
Superla	10516
Superscan	10864
Supersonic	10009, 10037, 10208, 10264, 10455, 10698, 10805
SuperTech	10009, 10037, 10216, 10218
Supervision	10264
Supra	10009, 10039, 10056, 10178
Supre-Macy	10046
Supreme	10000
Susumu	10218, 10287, 10335
SVA	10587, 10698, 10748, 10768, 10865, 10870, 10871, 10872
Svasa	10455
Swissline	10247
Sylvania	10020, 10030, 10054, 10096, 10171, 10381
Symphonic	10171, 10180
Synco	10000, 10036, 10060, 10092, 10093, 10178, 10451
Sysline	10037
Sytong	10216
T+A	10447
Tacico	10009, 10092, 10178, 10179
Tai Yi	10009
Taishan	10009, 10374, 10817
Tandberg	10362, 10367, 10411
Tandy	10039, 10072, 10093, 10163, 10217, 10218
Targa	10702
Tashiko	10032, 10036, 10092, 10146, 10163, 10216, 10217, 10359, 10363, 10650, 10721
Tatung	10003, 10009, 10011, 10036, 10037, 10051, 10054, 10055, 10060, 10072, 10154, 10156, 10217, 10516, 10556, 10621, 10629, 11156, 11254, 11756
TCL	10412, 10698, 10706, 10727, 10826, 11537
TCM	10714, 10808

Teac	10009, 10037, 10170, 10171, 10178, 10217, 10247, 10264, 10282, 10412, 10418, 10455, 10512, 10544, 10556, 10668, 10698, 10706, 10712, 10714, 10721, 10755, 11037, 11437, 11724, 11755
Tec	10009, 10037, 10163, 10217, 10247, 10259, 10337, 10361
Tech Line	10037, 10668, 11437
Techica	10218
Technema	10320
Technics	10051, 10250, 10556, 10650
TechniSat	10037, 10163, 10556, 10655
Technisson	10714
Technol Ace	10179, 10264, 10374, 10412
Technosonic	10556
Techview	10847
Techwood	10003, 10051, 10056, 11163
Tecnimagen	10556
Teco	10009, 10036, 10051, 10092, 10093, 10178, 10218, 10264, 10280, 10653
Tedelex	10009, 10037, 10208, 10217, 10264, 10418, 10556, 10606, 10706, 10726, 10891, 11537
Tek	10009, 10264, 10706, 10795
Teknika	10016, 10019, 10039, 10054, 10056, 10060, 10092, 10150, 10179, 10180, 10186
Telecor	10037, 10394
Telefunken	10037, 10056, 10073, 10109, 10287, 10335, 10346, 10421, 10486, 10498, 10560, 10587, 10625, 10698, 10702, 10706, 10712, 10714, 10753, 10819, 10820, 10821
Telefusion	10037
Telegazi	10037, 10556
Telemeister	10320
Telesonic	10037
Telestari	10009, 10037, 10412, 10556, 10579
Teletech	10009, 10037, 10337, 10668, 11037
Teleton	10036, 10163, 10186, 10206, 10217, 10259, 10363
Televideon	10216, 10320
Television	10037
Tempest	10009, 10037, 10264, 10455, 10556
Tennessee	10037
Tensai	10009, 10037, 10104, 10105, 10163, 10217, 10218, 10247, 10320, 10371, 10374, 10377, 10556, 10715, 11037
Tenson	10009, 10320
Tera	10030, 10092, 10466
Tesla	10037
Tevion	10556, 10648, 10668, 10714, 10767, 11037, 11137

Texet	10009, 10216, 10217, 10218, 10374
ThemeScene	10887
Thomson	10037, 10109, 10287, 10335, 10560, 10625, 11447
Thorn	10035, 10036, 10037, 10072, 10073, 10104, 10109, 10163, 10193, 10238, 10335, 10359, 10361, 10499, 10512, 10535
Thorn-Ferguson	10073, 10193, 10238, 10499
Tiane	10093, 10817
TMK	10056, 10177, 10178
TML	11756
TNCi	10017
Tobishi	10218
Tobo	10009, 10264, 10412, 10748
Tokai	10009, 10037, 10163, 10337, 10374, 10668, 11037
Tokaido	11037
Tokyo	10035
Tomashi	10218, 10282
Tongguang	10264, 10412
Tongtel	10587, 10780
Tophouse	10180
Toshiba	10009, 10035, 10036, 10060, 10070, 10093, 10102, 10109, 10145, 10154, 10156, 10191, 10195, 10217, 10264, 10381, 10412, 10508, 10556, 10618, 10644, 10650, 10714, 10718, 10821, 10832, 10845, 11156, 11256, 11265, 11356, 11508, 11656, 11704
Tosonic	10185
Totevision	10039
Towada	10102, 10217, 10264
Toyoda	10009, 10037, 10264, 10412
Trakton	10009, 10217, 10264
Trans Continens	10037, 10217, 10668, 11037
TRANS-continents	10621
Transonic	10009, 10037, 10264, 10418, 10455, 10512, 10587, 10698, 10712, 10780, 10858
Triad	10037, 10218, 10556
Trical	10157
Trident	10516
Tristar	10193, 10218
Triumph	10177, 10346, 10516, 10556
Tsoschi	10282
Tuntex	10009, 10030, 10092
TVS	10463
TVTEXT 95	10556
Uher	10037, 10206, 10320, 10374, 10418, 10480, 10486
Ultravox	10037, 10087, 10102, 10216, 10247
Unic	10163

Unic Line	10037, 10455
United	10037, 10606, 10714, 10715, 11037
Universal	10027, 10037
Universum	10009, 10011, 10032, 10036, 10037, 10070, 10104, 10105, 10146, 10157, 10163, 10170, 10177, 10191, 10200, 10217, 10247, 10264, 10290, 10346, 10361, 10362, 10370, 10411, 10418, 10421, 10473, 10480, 10492, 10512, 10535, 10544, 10556, 10618, 10631, 10668, 11037, 11437
Univox	10037, 10087, 10163, 10337
Utax	10163
V2max	10865
V7 Videoseven	11755
V7Videoseven	10880
Vector Research	10030
Vestel	10037, 10163, 10217, 10556, 10668, 11037, 11163
Victor	10036, 10053, 10250, 10650, 10653
Videocon	10508
Videologic	10216, 10218
Videologique	10218
Videomac	10009, 10264
Videosat	10247
Videotechnic	10217, 10320
Videoton	10356
Vidikron	10054
Vidtech	10019, 10036, 10178
Viewsonic	10724, 10857, 10864, 10885, 11755
Viking	10046
VInc	11756
Vision	10032, 10037, 10217, 10264, 10320
Vistar	10206, 10361, 10548
Vizio	10864, 10885, 11756
Voxson	10087, 10163, 10178, 10363, 10418
Waltham	10037, 10109, 10163, 10217, 10356, 10418, 10443, 10668, 11037
Wards	10000, 10016, 10017, 10018, 10019, 10020, 10021, 10024, 10027, 10030, 10047, 10051, 10054, 10055, 10056, 10060, 10080, 10096, 10111, 10135, 10154, 10156, 10165, 10166, 10178, 10179, 10180, 10186, 10187, 10866, 11147, 11156, 11347
Warumaia	10374, 10661
Watson	10009, 10037, 10218, 10320, 10394, 10579, 10668, 11037, 11437
Watt Radio	10102, 10216, 10544
Waycon	10156
Wega	10036, 10037, 10087
Wegavox	10037

Weipai	10009
Welltech	10714
Weltblick	10217, 10320
Westinghouse	10003, 10889
Weston	10037
Wharfedale	10037, 10264, 10556, 10706, 10861
White Westinghouse	10037, 10186, 10216, 10320, 10337, 10463, 10623
Windsor	11037
Windstar	10282, 10337
Windy Sam	10556
Wintel	10714
World-of-Vision	10880
Worldview	10455
Xenius	10634, 10661
Xiahua	10009, 10264, 10412, 10698, 10773, 10779, 10817
Xianghai	10009
Xiangyang	10264, 10412
Xiangyu	10009
Xihu	10264, 10412, 10817
Xinanghai	10412
Xingfu	10009
Xinghai	10264
Xinrisong	10848
XLogic	10698
XMS	10698
Xoceco	10779, 10785
Xrypton	10037
Xuelian	10848
Yamaha	10019, 10030, 10650, 10769, 10833, 10839
Yamishi	10217, 10282, 10455
Yapshe	10250
Yingge	10009
Yokan	10037, 10109
Yoko	10009, 10037, 10216, 10217, 10218, 10247, 10264, 10339, 10421
Yongbao	10848
Yonggu	10009
Yoshita	10706
Youlanasi	10817
Yousida	10009, 10848
Yuhang	10009
Zanela	10238
Zanussi	10206, 10264, 10363
Zenith	10016, 10017, 10092, 10178, 10463
Zenor	10208, 10339
ZhuHai	10009, 10374
Zonda	10003, 10698, 10779
ZX	10418

CABLE

ABC	00003, 00007, 00008, 00011, 00013, 00014, 00017, 00237	GE	00237
ADB	01063, 01269	Gehua	00476
Aichi Denshi	01512	Gemini	00015, 00797
Alcatel	00896	General Instrument	00003, 00011, 00014, 00015, 00276, 00476, 00810
Allegro	00153, 00315	GMI	00015, 00797
Americast	00899	Golden Channel	01063, 01110
Amstrad	01222	GoldStar	00040, 00144
Antronix	00022	Goodmind	00797
Archer	00022, 00153, 00797	Hamlin	00009, 00020, 00034, 00259, 00273
Auna	00277, 01269	Hitachi	00011, 00014
Austar	00012, 00276	HyperVision	00619
Bell & Howell	00014	Hytex	00007
Bell South	00899	i3 Micro	01602
Birmingham Cable Communications	00276	Jasco	00015, 00153, 00315
British Telecom	00003	Jebsee	00400
Cable & Wireless	01068	Jerrold	00003, 00011, 00012, 00014, 00015, 00276, 00476, 00810
Cabletenna	00022	KNC	00008
Cabletime	00448, 00665	Leon	00015
Cableview	00022	LG	00040, 00144
Canal Plus	00443	Macab	00817
Century	00153	Magnavox	00014
Citizen	00153, 00315	Maspro	01510
Clearmaster	00883	Memorex	00000
ClearMax	00883	MNET	00019, 00443
Comcrypt	00443	Moser	00451
Comtronics	00040	Motorola	00276, 00476, 00810, 01106, 01187, 01254, 01376, 01483
Contec	00019	Movie Time	00063
Coolmax	00883	Mr Zap	01112
Cryptovision	00600	Mr. Zap	01112
Daeryung	00008, 00277, 00477, 00877, 01877	MS	00015
Digeo	01187	Multichoice	00019, 00443
Digi	00637	Multitech	00883
Director	00476	MultiVision	00012
Dumont	00637	Myrio	01602
DX Antenna	01500	NEC	01496
Eastern	00002	Nokia	01569
Emerson	00797	Noos	00817
Everquest	00015, 00040	NSC	00063
Filmnet	00443, 00619	NTL	00003, 00250, 00277, 01060, 01068
Focus	00400	Oak	00007, 00019
Foxtel	01222	Ono	01068
France Telecom	00451, 00817, 00896	Optimus	00021
Freebox	01482	Optus	00276, 01060
Fujitsu	01497	Pace	00008, 00237, 01060, 01068, 01368, 01877
Funai	00019	Panasonic	00000, 00008, 00021, 00040, 00107, 00443, 01488
Galaxi	00008	Panther	00637
Garrard	00153		

Paragon	00000
Philips	00013, 00153, 00317, 00619, 00817, 01305
Pioneer	00144, 00533, 00877, 01500, 01877
Popular Mechanics	00400
Pulsar	00000
PVP Stereo Visual Matrix	00003
Quasar	00000
Quiero	00817
RadioShack	00015, 00315, 00797, 00883
RCA	00021, 01256
Recoton	00400
Regal	00020, 00259, 00273, 00279
Regency	00002
Rembrandt	00011
Runco	00000
Sagem	00817, 01089, 01112
Salora	00000
Samsung	00000, 00040, 00144, 01060
Scientific Atlanta	00008, 00017, 00237, 00277, 00477, 00877, 01510, 01877
Sejin	01602
Signal	00015, 00040
Signature	00011
SL Marx	00040
Sony	01006, 01460
Sprucer	00021
Starcom	00003, 00014, 00015
Stargate	00015, 00040, 00797
Starquest	00015
Sumitomo	01500, 01504
Supercable	00276
Supermax	00883
Tadiran	00040
Tandy	00258
Tele Danmark	01016
Tele+1	00443
Telepiu	00443
Television	00040
Telewest	01068, 01368
Thomson	01110, 01256
Time Warner cable	01877
Timeless	00040
Tocom	00012, 00013
Torx	00003
Toshiba	00000, 01509
Trans PX	00153, 00276, 00315
TransACT	01106
Tri-Vision	01257
Tristar	00883

TS	00003
Tusa	00015
TV86	00063
Unika	00022, 00153
United Artists	00007
United Cable	00003
Universal	00022, 00153, 00191
US Electronics	00276
V2	00883
Videotron	00250
Videoway	00250
Viewmaster	00883
Viewstar	00063, 00258
Vision	00883
Visionetics	01064
Visiopass	00451
Vortex View	00883
Zenith	00000, 00008, 00525, 00899
Zentek	00400

SATELLITE

@sat	01300
@Sky	01334
ABsat	00123, 00668, 00713, 00832
ADB	00642, 00887, 01259, 01367, 01473, 01491, 01492, 01493, 01494, 01495
Aegir	00520
AGS	00668, 00710
Aiwa	01514
Akai	00200, 00515
Akena	00668
Alba	00421, 00455, 00515, 00613, 00713
Aldes	00520
Allsat	00200, 01017, 01043
Allsonic	00369
Alltech	00713
Allvision	01232, 01334, 01412
Alpha	00668
AlphaStar	00772
Amitronica	00713
Ampere	00132, 00396, 00829
Amstrad	00132, 00243, 00345, 00396, 00501, 00675, 00689, 00713, 00742, 00795, 00847, 00863, 00882, 00885, 01113, 01175
Anglo	00713
Ankaro	00369, 00692, 00713, 01279
AntSat	01017, 01083
Anttron	00421, 00613
Apollo	00421, 00455
Arcon	00692, 00834, 01043, 01075, 01205, 01279

Arcus	01143
Arion	01205
Armstrong	00243
Arnion	01300
ASA	00397
Asat	00200
ASCI	00114, 01334
ASLF	00713
AssCom	00853
AST	00321, 00351
Astacom	00668, 00710
Aston	00142, 01261
Astra	00243, 00607, 00713
Astrastar	00548
Astro	00133, 00173, 00358, 00369, 00501, 00520, 00548, 00607, 00613, 00658, 01099, 01100, 01113
Athena	00668
Atsat	01300
AtSky	01334
Audioline	01429
Audioton	00613
Aurora	00642, 00879
Austar	00497, 00642, 00863, 00879, 01173, 01259
Avalon	00396
Axiel	00668, 00710
Axis	00369, 00834, 00880, 01111
Beko	00455
Bentley Walker	01017
Best	00369
Bestar	00243
Black Diamond	01284
Blaupunkt	00173
Blue Sky	00713, 00885
Boca	00132, 00243, 00713, 00794, 00829, 01232
Boston	00132, 00668, 00710
Brainwave	00692, 01294
British Sky Broadcasting	00847, 01175, 01847
Broco	00713
BskyB	00847, 01175
BT	00515, 00668, 00710
Bubu Sat	00713
Bush	01284, 01471
BVV	00692
Cambridge	00501, 00515
Canal Digital	00853
Canal Satellite	00853, 01339
Canal+	00853
CanalSatellite	00853, 01339

CCE	00345
Century	00856
Channel Master	00212
Chaparral	00053, 00209, 00216
Cherokee	00123, 00710, 01480
Chess	00114, 00713, 01085, 01334
CityCom	00115, 00299, 00607, 00818, 01075, 01176, 01232
Claasen Nachrichten	00520
Clark	00613
Clemens Kamphus	00396, 00834
CNS	01367
CNT	00520
Cobra	00396
Colombia	00132, 00668
Columbia	00132
Columbus	00668
Comag	00132, 01232, 01412
Condor	00369, 00607
Connexions	00396
Conrad	00115, 00132, 00369, 00501, 00607
Conrad Electronic	00607
Cosat	00592
Crossdigital	01109
Crown	00243
Cryptovision	00455
Cyfra+	01076
Cyrus	00200
D-box	00723, 00873
Daeryung	00396
Daewoo	00421, 00713, 01111, 01296
Daumling	00794
Delfa	00863
Deltasat	01075
Dgtec	01242, 01542
Digatron	01294
Digena	01100
Digenius	00299, 01161
Digitality	00607
Digipro	01105
DigiQuest	00863
DigitAll World	01227
Digiturk	01076
DirecTV	00099, 00247, 00392, 00566, 00639, 00724, 00749, 00819, 01076, 01108, 01109, 01142, 01377, 01392, 01414, 01442, 01443, 01444, 01609, 01639, 01640, 01749, 01856
Discoverer	00605
Discovery	00668, 00710, 01480
Dish Network	00775

Dish Network System	00775, 01005, 01170, 01505, 01775
Dishpro	00775, 01005, 01505, 01775
Distratel	00084, 00885, 01205, 01283
Distrisat	00200
DMT	01075
DNR	00692
DNT	00200, 00396
Dream Multimedia	01237, 01437, 01537, 01637
DST	00421
Dune	00369
DX Antenna	01530
Echostar	00159, 00167, 00269, 00280, 00396, 00454, 00610, 00668, 00713, 00775, 00853, 00871, 01005, 01086, 01170, 01200, 01323, 01409, 01467, 01477, 01505, 01775
EIF	00417
Einhell	00132, 00243, 00421, 00501, 00692, 00713, 00794
Elap	00587, 00668, 00710, 00713
Elsat	00713
Elta	00200, 00369, 00421
Emanon	00421
Emme Esse	00369, 00871
eMTech	01214
Engel	00713, 01017
Eurieult	00084, 00136, 00417, 00882, 00885
Euro1	01278
Eurocrypt	00455
EuroLine	01251
Europa	00501, 00607, 00863
European	00794
Europhon	00132, 00299, 00607
Eurosat	00243
Eurosky	00114, 00115, 00132, 00243, 00299, 00369, 00501, 00607
Eurostar	00115, 00607, 00818, 00880, 00898
Eutelsat	00713
Exator	00421, 00515, 00613
Expressvu	00775, 01775
Fagor	00592
Fenner	00157, 00369, 00605, 00668, 00713
Ferguson	00455, 00711, 01291
Fidelity	00501, 00675
Finlandia	00455
Finlux	00397, 00455, 00573
Flair Mate	00713
Force	01101, 01194
Fortec Star	01017, 01083, 01293

Foxtel	00455, 00497, 00720, 00879, 01162, 01173, 01176, 01356
Fracarro	00421, 00668, 00871
Freecom	00173, 00421, 00501
Freesat	00882
Fresat	00885
FTEmaximal	00331, 00369, 00713, 00794, 00863, 01209, 01449
Fuba	00115, 00173, 00299, 00369, 00396, 00417, 00421, 00573, 01161, 01214
Fugionkyo	01105
Galaxis	00115, 00369, 00592, 00692, 00834, 00853, 00863, 00879, 01101, 01111, 01557
Galaxisat	00321
Gardiner	00818
Garnet	01075
GbSAT	01214
GE	00566
Gecco	01273, 01412
General Instrument	00869
GF	00834, 01043
GF Star	01043
Globo	01087, 01251
GOD Digital	00200
GOI	00775, 01775
Gold Box	00853
Goldbox	00292, 00853
Golden Interstar	01283
Goldvision	01017
Gooding	00571
Goodmans	00455, 01246, 01284
Gradiente	00099, 00856, 00887
Granada	00455
Grandin	00084, 00136, 00417, 00885
Grococ	00243
Grundig	00173, 00345, 00455, 00501, 00571, 00750, 00805, 00847, 00853, 00879, 01150, 01291, 01330, 01335, 01435
Hanseatic	00605, 01099, 01100
Hantor	00421
Hanuri	00520
Hauppauge	01294, 01298
HB	01214
HDT	01011, 01159
Helium	00607
Hinari	00421
Hirschmann	00173, 00299, 00369, 00396, 00397, 00501, 00573, 00607, 00668, 00710, 00882, 01012, 01085, 01111, 01113
Hisense	01535

Hitachi	00455, 00489, 00819, 01250, 01284, 01518, 01523, 01525, 00035
Hnsel & Gretel	00132
Homecable	00238
Homecast	01214
Houston	00396, 00592, 00668
HTS	00775, 01775
Hughes	00749
Hughes Network Syst	00749
Hughes Network Systems	00749, 01142, 01442, 01443, 01444, 01749
Humax	00863, 01176, 01225, 01427, 01568
Huth	00132, 00243, 00607, 00692, 00794, 00829, 01017, 01075
Hwalin	00885
Hypson	00136, 00417
Hyundai	01011, 01075, 01159
iCan	01367
ID Digital	01176
IEEC	00605
ILLUSION sat	01557
iLo	01535
Imex	00084, 00136, 00520
Imperial	01429
Indovision	00887
Ingelen	00114, 00396, 00882
Innova	00099
International	00132, 00243
Interstar	01017, 01105, 01214
Intertronic	00243
Intervision	00592, 00607, 00628
InVideo	00871
IQ	00210
IQ Prism	00210
IR	00173, 00282, 00331, 00358, 00455
Irdeto Technology	00879
ISkyB	00887
Italtel	00871
Jadeworld	00642
Jaeger	01334
Janeil	00152
JOK	00690, 00710
Jolly	00592
JVC	00492, 00515, 00571, 00775, 01170, 01507, 01531, 01775
K-SAT	00713
Kamm	00713, 00880
Kaon	01300
KaTelco	01111

Kathrein	00114, 00115, 00123, 00173, 00200, 00249, 00331, 00358, 00442, 00480, 00553, 00613, 00658, 00713, 00742, 00818, 00898, 01057, 01221, 01561, 01567
Kathrein Eurostar	00115
Kenwood	00853
Key West	00132, 00794
Kiton	00114
Klap	00668, 00710
Kolon	00421
Konig	00607
Koscom	00834, 01043, 01334, 01409
Kosmos	00331, 00442
KR	00592, 00613
Kreiling	00114, 00249, 00658, 01461, 01480
Kreismeyer	00173
Kyostar	00421, 00613
L&S Electronic	00132, 00369, 01043, 01334
Labgear	01296
LaSAT	00115, 00132, 00157, 00173, 00243, 00299, 00369, 00520, 00607
Legend	00269
Lemon	00692, 01461
Lenco	00115, 00369, 00421, 00607, 00628, 00692, 00713
Lennox	00592
Lenson	00501
Leyco	00515
LG	01075, 01226, 01414
Lifesat	00132, 00157, 00299, 00369, 00605, 00713, 01043, 01122
Lifetec	00587
Lodos	01284
Loewe	00243
Logix	01017, 01075
Lorenzen	00132, 00299, 00607, 00692, 00742, 00794, 00867, 01161, 01294
Lupus	00369
Luxor	00345, 00501, 00573
M vision	01557
Magnavox	00722, 00724
Manata	00132, 00136, 00417, 00668, 00710, 00713
Manhattan	00455, 00520, 00592, 00834, 01017, 01083
Marantz	00200
Marave	00417
Mascom	00520
Maspro	00173, 00571, 00692, 00713, 00750, 01530
Mastec	01334
Matsui	00173, 00571, 00710, 01284
Matsushita	00500

Max	00607
Maximum	01075, 01334
MB	00605
MDS	01225
Mediacom	01206
Mediamarkt	00243
MediaSat	00292, 00501, 00853
Medion	00132, 00299, 00369, 00713, 01043, 01075, 01161, 01232, 01334, 01412
Medison	00713
Mega	00200
Meletronic	00818
Memorex	00269, 00724
Metronic	00084, 00132, 00136, 00243, 00421, 00520, 00613, 00713, 00818, 00885, 01205, 01215, 01279, 01282, 01283, 01334
Metz	00173
Micro	00501, 00607, 00613, 00713, 01294
Micro electronic	00713
Micromaxx	00299, 00369
Microstar	01075
Microtec	00713
Minerva	00571
Mitsubishi	00455, 00749
Morgan's	00132, 00200, 00243, 00713, 00794, 00829, 01232
Motorola	00856, 00869
Multichoice	00642, 00879
Multistar	00331
Myryad	00200
Mysat	00713
NEC	00496, 01270, 01519
NEOTION	01334
Netgem	01322
Netsat	00099, 00887
Neuhaus	00501, 00592, 00607, 00692, 00713, 00834
Neuling	00132, 01232
Neusat	00587, 00692, 00713, 00834, 01279, 01334, 01409
Neveling	01161
Newton	00396
Next Level	00869
NextWave	01017, 01143
Nikko	00200, 00243, 00713
Nokia	00397, 00455, 00573, 00723, 00751, 00853, 00873, 01023, 01223, 01310, 01311, 01312, 01723
Nordmende	00421, 00455, 00520
Octagon	00421, 00613
OctalTV	01294, 01505

Okano	00243, 00331, 00442, 00668
Opentel	01232, 01412
Optex	00114, 00136, 00417, 00592, 00834, 01043, 01283
Optus	00879, 01143
Orbis	01334
Orbit	00351
Orbitech	00114, 00157, 00421, 00501, 00548, 00834, 01099, 01100
Origo	00497
OSAT	00345
Ouralis	01205
Oxford	00515, 00668
Pace	00200, 00241, 00329, 00455, 00497, 00720, 00791, 00795, 00847, 00853, 00867, 00879, 00887, 01175, 01323, 01356, 01423, 01623
Pacific Satellite	00834
Packard Bell	01111
Packsat	00710
Palcom	00299, 00587, 01161
Palladium	00243, 00396, 00421, 00501, 00571
Palsat	00157, 00501
Panarex	01159
Panasat	00615, 00879
Panasonic	00152, 00247, 00455, 00500, 00701, 00847, 01304, 01320, 01404, 01508, 01526
Panda	00173, 00455, 00607, 00834
Pansat	01011, 01159
Patriot	00132, 00515, 00668, 00710
Paysat	00724
Philips	00099, 00133, 00173, 00200, 00292, 00455, 00571, 00613, 00668, 00710, 00722, 00724, 00749, 00750, 00805, 00818, 00853, 00856, 00887, 00898, 01076, 01114, 01118, 01142, 01442, 01749
Phoenix	01273
Phonotrend	00592, 00863, 01017, 01200
Pilotime	01339
Pino	01334
Pioneer	00292, 00329, 00352, 00853, 01308
Planet	00396, 00871
Plasmatic	00442
Polytron	00396
Praxis	01123
Predki	00421
Preisner	00132, 00396, 00794, 01101, 01113
Premier	00292, 00592
Premiere	00292, 00723, 00873, 01429
Prima	00795
Primacom	01111

Pro Visat	00520
Prod	00573, 00639, 00723, 00873
Profile	00710
Promax	00455
Prosat	00628, 01173
Proscan	00392, 00566
Protek	01567
Proton	01535
ProVision	00520
Pye	00571
Pyxis	00834
QNS	01367, 01404
Quadral	00369, 00628, 00668, 00710, 01012
Quelle	00115, 00299, 00607, 00742
Radiola	00200
RadioShack	00869
Radix	00285, 00396, 00882, 01113
Rainbow	00613
RCA	00143, * [00392] , 00566, 00855, 01291, 01392
Realistic	00052
Rebox	01214
Red Star	00369
Regal	01251
RFT	00200
Roadstar	00713, 00853
Roch	00136
Romsat	00421
Rover	00369, 00628, 00713
S-ZWO	01207
SAB	01251
Saba	00115, 00520, 00607, 00690, 00692, 00710, 00885, 01012
Sabre	00455
Sagem	00820, 01114, 01253, 01307
Samsung	00853, 00863, 01017, 01108, 01109, 01206, 01243, 01244, 01276, 01292, 01293, 01343, 01377, 01442, 01458, 01570, 01609
Sanyo	00493, 01219
SAT	00321, 00351, 00501, 00675
Sat Control	01300
Sat Cruiser	01143
Sat Partner	00421, 00501, 00520, 00613, 00692
Sat Team	00713
Satcom	00605, 00607
Satec	00713, 00834
Satelco	00369, 01232
Satline	00628
Satplus	00157, 01100
Satstation	01083

Schaub Lorenz	01214
Schcke	00613
Schneider	00157, 00668, 00710, 00805, 00898, 01206, 01251
Schwaiger	00132, 00157, 00587, 00605, 00607, 00692, 00863, 00885, 01075, 01083, 01111, 01334, 01474
SCS	00115, 00299
Sedea Electronique	00132, 00421, 01105, 01206, 01283
Seemann	00243, 00396, 00515
SEG	00114, 00369, 00421, 00605, 00742, 01075, 01087, 01191, 01251
Seleco	00592, 00871
Septimo	00885, 01205
Serino	00610
Servi Sat	00136, 00592, 00713
ServiSat	01251
Sharp	00494, 01517
Siemens	00173
Silva	00299
Skantin	00713
Skardin	00587
SKR	00713
SKT	01449
SKY	00099, 00711, 00847, 00856, 00887, 01014, 01175, 01847, 01848, 01856
SKY Italia	01847, 01848
Sky Television	01014
Sky XL	01251, 01412
Sky+	01175
Skymaster	00157, 00587, 00605, 00628, 00713, 00880, 01075, 01085, 01200, 01409
Skymax	00200
Skyplus	01232, 01334, 01409, 01412
SkySat	00114, 00157, 00501, 00605, 00607, 00713
Skyvision	01334
SL	00132, 00243, 00299, 00692, 00742, 01294
SL Marx	00692
SM Electroni	00157, 00587, 00713, 01200, 01409
Smart	00115, 00132, 00299, 00396, 00713, 00794, 00829, 00882, 01101, 01113, 01232, 01273
Sony	00275, 00282, 00292, 00294, 00486, 00489, 00492, 00493, 00494, 00496, 00500, 00639, 00847, 00853, 01524, 01558, 01639, 01640
SR	00132, 00243
Star	00887
Star Choice	00869
Star Trak	00180, 00421
Starland	01122
Starlite	00200

Stream	01847, 01848
Strong	00132, 00369, 00421, 00520, 00613, 00853, 00879, 01105, 01147, 01158, 01159, 01300, 01409
STS	00210
STVI	00136, 00417
Sunkai	00123
Sunny	01300
Sunny Sound	00369
Sunsat	00713
Sunstar	00132, 00243, 00369, 00642, 00794, 00829
Supermax	01143, 01283
Supernova	00887
Tantec	00455
Tarbs	01225
Tatung	00455
TCL	01143
Teac	01225, 01227, 01251, 01322
Techniland	00592
TechniSat	00114, 00157, 00200, 00396, 00455, 00501, 00548, 00863, 01099, 01100, 01195, 01322
Technomate	01283
Technosat	01143, 01206
Technotrend	01429
Technowelt	00132, 00607
Techsan	01017
Techwood	00114, 01284
Teco	00243
tekComm	01017
Telasat	00115, 00605, 00607
Teleciel	00613, 01043
Telefunken	00421
Teleka	00243, 00396, 00501, 00607, 00613, 00692, 00750, 00834
Telemaster	00520
Telesat	00605
Telestari	00114, 00157, 00501, 01099, 01100, 01251, 01334
Telesystem	00396, 01251
Teletech	00114, 00880
Televés	00132, 00455, 00501, 01214, 01300
Televisa	00887
Telewire	00592
Tempo	01143
Tevion	00713, 01334, 01409
Thomson	00115, 00292, 00392, 00455, 00607, 00668, 00710, 00711, 00713, 00820, 00847, 00853, 01012, 01046, 01175, 01291, 01498, 01900
Thorn	00455
Tioko	00132, 00243

Tivo	01142, 01442, 01443, 01444
Tokai	00200
Tonna	00455, 00501, 00587, 00592, 00668, 00713, 00834
Topfield	01206, 01207, 01545
Toshiba	00082, 00455, 00486, 00749, 00790, 01285, 01446, 01501, 01516, 01530, 01749
TPS	00820, 01253, 01307
Triad	00321, 00351, 00372
Triasat	00501
Triax	00114, 00115, 00132, 00200, 00396, 00501, 00713, 00853, 01099, 01113, 01227, 01251, 01291, 01296
Trio	01075
TT-micro	01429
Turnsat	00713
Twiner	00136, 00713
UEC	00879, 01162
Uher	00157
UltimateTV	01392, 01640
Uniden	00052, 00074, 00076, 00238, 00722, 00724, 00834
Unisat	00132, 00200, 00243
United	01251
Universum	00114, 00115, 00173, 00299, 00397, 00571, 00607, 00675, 00742, 01087, 01099, 01251
US Digital	01535
USDTV	01535
Van Hunen	01161
Variosat	00173
Vega	00369
Ventana	00200
Vestel	00114, 00742, 01251
Victor	00492
Visionic	01105, 01206, 01279, 01283
Visiosat	00114, 00142, 00690, 00710, 00713
Vivid	01162
Voom	00869
Vortec	00421
VTech	00321, 00351, 00690, 00818
Welltech	00157
Wetekom	00157, 00501, 00605, 00829
Wewa	00455
Wibo	00243
Wintel	00299, 01161
Wisi	00173, 00299, 00321, 00351, 00372, 00396, 00455, 00501, 00607, 00638, 00690
Woorisat	00520
Worldsat	00114, 00123, 00668, 00710, 01012, 01251, 01323, 01480

Xcom	00123, 00668, 00832
Xcom Multimedia	00668
XMS	01075
Xrypton	00369
Xsat	00123, 00668, 00713, 00847, 01214, 01323
Xtreme	01300
Yes	00887
Zaunkonig	00692
Zehnder	00114, 00115, 00321, 00331, 00369, 00520, 00742, 00818, 01075, 01191, 01232, 01251, 01334, 01412
Zenith	00856, 01856
Zinwell	01173
Zodiac	00396, 00613
Zwergnase	00243, 00794

CD

Acoustic Research	30420
ADC	30018
Adcom	30155, 30234
Advantage	30032
Aiwa	30012, 30124, 30157, 31690
Akai	30156, 30766, 31688
Arcam	30157
Audio Alchemy	30194
Audio Dynamics	30018
Audio Pro	30437
Audio Research	30157
Audio-Technica	30170
Audiolab	30157
Audiomeca	30157
Audioton	30157
Bestar	30164
BSR	30194, 30245
Burmester	30420
Bush	30245
Cairn	30157
California Audio Labs	30029, 30303
Cambridge	30157
Carrera	30194
Carver	30157, 30179, 30437
CCE	30157
CDC	30420
CEC	30174, 30420
Classic	31297
Condor	30164, 30194
Copland	30393
Crown	30122
Cyrus	30157
DAK	30245

DBX	30018, 30254
Denon	30003, 30626, 30766, 30873, 31234, *[31867], 31868
DKK	30000
DMX Electronics	30157
Dual	30003, 30194, 30196
Dynamic Bass	30179
EEC	30194
Elektra	30437
Emerson	30155, 30164, 30305, 30469
Fisher	30088, 30174, 30179, 30342, 31325
Garrard	30245, 30280, 30393, 30420, 30425
GE	30009
Genexxa	30032, 30164, 30305, 30426
Goldmund	30157
GoldStar	30417, 31208
Goodmans	30245, 30280, 30305
GPX	31296
Grundig	30157
Harman/Kardon	30157, 30173, 30426, 31202
Hitachi	30032, 30155, 30038
Inkel	30180, 30196, 30437
Integra	30101
Intersound	30245
IR	30000
JVC	30072, 30655, 31294, 31697
Kenwood	30028, 30036, 30037, 30157, 30190, 30626, 30681, 30826
KLH	31318, 31711
Kodak	30287
Korsun	31484
Koss	31317
Krell	30157
Kyocera	30018
LG	31208
Linn	30157
Loewe	30157
Luxman	30093, 30393
LXI	30305
Magnavox	30157, 30305
Marantz	30029, 30157, 30180, 30626
Mark	30194
Mark Levinson	31484
Matsui	30157
McIntosh	30287
MCS	30029, 30043
Memorex	30032, 30155, 30164, 30175, 30180, 30305
Meridian	30157
Micromega	30157
Miro	30000

Mission	30157
Mitsubishi	30156
MTC	30420
Musical Fidelity	30393, 30437
Myryad	30157
NAD	30000, 31208
Nagaoka	30018
Naim	30157
Nakamichi	30147
NEC	30043, 30234
Nikko	30164, 30170, 30174
NSM	30157
Oak	30145
Onkyo	30101, 30868, 31685
Optimus	30000, 30032, 30037, 30087, 30145, 30175, 30179, 30194, 30196, 30280, 30305, 30342, 30420, 30426, 30437, 30468, 31063, 31075
Orion	30393
Panasonic	30029, 30207, 30303, 30752, 31682
Parasound	30194, 30420
Penney	30043
Perform Hifi	30420
Philips	30157, 30287, 30626
Pioneer	30032, 30101, 30305, 30468, 31062, 31063, 31087
PMG	30164
Polk Audio	30157
Poppy	30164
Proceed	30420
Proton	30157
QED	30157
Quad	30157
Quasar	30029
Radiola	30157
RadioShack	31075
RCA	30009, 30032, 30053, 30155, 30179, 30305, 30420, 30468, 30764, 31062
Realistic	30155, 30164, 30175, 30179, 30180, 30420
Restek	30157
Revox	30157
Roadstar	30461
Roksan	30420
Rotel	30157, 30420
Royal	30164, 30420
SAE	30157
Sansui	30157, 30202, 30305
Sanyo	30087, 30179, 30342
SAST	30157
Scott	30155, 30164, 30305
Sears	30305

Sharp	30037, 30180, 30861, 31658, 31684
Sherwood	30180, 30196, 30426, 31067
Shure	30043
Siemens	30157, 30180
Silsonic	30036, 30888
Simaudio	30157
Sonic Frontiers	30157
Sony	30000, 30100, 30185, 30490, 30604, 30605, 31364
Soundesign	30145, 30425
STS	30018
Sugden	30157
Symphonic	30305
TAG McLaren	30157
Tandy	30032
Tascam	30420
TDK	31208
Teac	30174, 30180, 30393, 30420
Tec	30245
Technics	30029, 30207, 30303
Thomson	30053
Thorens	30157
Thule Audio	30157
Tivoli Audio	31553
Tokai	30164, 30420
Toshiba	31693
Traxdata	30626
Universum	30053, 30157, 30437
Vector Research	30194, 30417
Victor	30072
Wards	30000, 30032, 30053, 30087, 30157, 30179
Yamaha	30000, 30032, 30036, 30037, 30170, 30187, 30888, 31292
Yoko	30194
Yorx	30461
Zonda	30157

CDR

Classic	31297
Denon	30626, 30766, 31868
Fisher	31325
GPX	31296
Harman/Kardon	31202
JVC	30072, 31294
Kenwood	30626
LG	31208
Marantz	30626
NAD	31208
Philips	30626
Pioneer	31062, 31087

RCA	30053, 30420
Sony	30000, 30100, 31364
TDK	31208
Teac	30420
Yamaha	30888, 31292

TAPE

Aiwa	20029, 20197, 20200, 21315
Akai	20283, 20439
Arcam	20076
Carver	20029
Denon	20076, 20371, 21311, 21471
Fisher	20074
Garrard	20308, 20309, 20375, 20439
Genexxa	20439
GoldStar	20353, 20375
Grundig	20029, 20229, 20375
Harman/Kardon	20029, 20182, 21314
Inkel	20070, 20071, 20337
JVC	20244, 20273, 20274, 20303, 20304, 20310, 21309
Kenwood	20070, 20071, 20092, 20233, 20234, 21364
LG	20375
Luxman	20308, 20309
Magnavox	20029
Marantz	20009, 20029
Memorex	20099
Mitsubishi	20283, 20439
Myryad	20029
Onkyo	20135, 20136, 20282
Optimus	20027, 20220, 20337, 20439
Orion	20308, 20309, 20353
Panasonic	20229
Philips	20029, 20229
Phonotrend	20337
Pioneer	20027, 20099, 20220, 21306, 21312
Polk Audio	20029
Radiola	20029
RCA	20027, 20220
Revox	20029, 20190
Sansui	20009, 20029
Sanyo	20074
Sharp	20231, 20371
Sherwood	20337
Siemens	20029
Sonic	20375
Sony	20170, 20234, 20243, 20291, 21313
TaeKwang	20439
Tandberg	20109
Teac	20280, 20283, 20289, 20308, 20309

Technics	20229, 20353
Thorens	20029
Universum	20375, 20439
Victor	20244, 20273, 20274
Wards	20027, 20029
Wharfedale	20439
Yamaha	20094, 20097

PVR ※1

ABS	21972
Alienware	21972
CyberPower	21972
Dell	21972
DirecTV	20739
Gateway	21972
Hewlett Packard	21972
Howard Computers	21972
HP	21972
Hughes Network Systems	20739
Humax	20739
Hush	21972
iBUYPOWER	21972
Linksys	21972
Media Center PC	21972
Microsoft	21972
Mind	21972
Niveus Media	21972
Northgate	21972
Panasonic	20616
Philips	20618, 20739
RCA	20880
ReplayTV	20614, 20616
Sonic Blue	20614, 20616
Sony	20636, 21972
Stack 9	21972
Systemax	21972
Tagar Systems	21972
Tivo	20618, 20636, 20739
Toshiba	21008, 21972
Touch	21972
Viewsonic	21972
Voodoo	21972
ZT Group	21972

TV/DVD Combination ※2, ※3

Advent	41016
Apex Digital	40830
Audiovox	41071, 41121, 41122
Axion	41071

Broksonic	40695
Bush	40516, 40713, 40884
Denver	41353, 41359
Emerson	41268
Go Vision	41071
Grundig	40695
Hitachi	41247
Jensen	41016
Konka	40719, 40720
Panasonic	41490
Philips	40854, 41260
Prima	41016
RCA	41022
Samsung	40899
Sansui	40695
Sova	41122
Sylvania	40675, 41268
Toshiba	40695
Bush ※3	10698, 11037
Denver ※3	10587
Sylvania ※3	10171

TV/VCR Combination ※3, ※4

America Action ※3	10180
Audiovox ※3	10180
Emerson ※3	10236
Funai ※3	11977

※4

Aiwa	20000, 20479
America Action	20278
Audiovox	20278
Broksonic	20002, 20479, 21479
Citizen	21278
Colt	20072
Curtis Mathes	21035
Daewoo	21278
Emerson	20002, 20294, 20479, 21278, 21479
Funai	20000, 21333
GE	20240, 20807, 21035, 21060
GoldStar	21237
Harley Davidson	20000
Hitachi	20000
Lloyd's	20000
Magnasonic	21278
Magnavox	20000, 21781
Magnin	20240
Memorex	20162, 21237
MGA	20240
Mitsubishi	20043, 20807

Optimus	20162
Orion	20002, 20479, 21479
Panasonic	20162, 21035, 21308
Penney	20240, 21035, 21237
Philco	20479
Quasar	20162, 21035
RadioShack	20000
RCA	20240, 20807, 21035, 21060
Samsung	20432, 21014
Sansui	20000, 20479, 21479
Sanyo	20240, 21330
Sears	20000, 21237
Sharp	20807
Sony	20000, 21232, 21295
Sylvania	21781
Symphonic	20000
Teac	20000
Thomas	20000
Toshiba	20845, 21145, 21323
Zenith	20000, 20479, 21479

TV/VCR/DVD Combination ※2, ※4

Akai	40899
Broksonic	40868
Emerson	40821
Funai	41334
Magnavox	40821
Panasonic	41362, 41462
RCA	41132
Sharp	40630
Superscan	40821
Sylvania	40821
Toshiba	41045
Sharp ※4	20807

CABLE/PVR Combination ※1

Americast	00899
Digeo	01187
Freebox	01482
General Instrument	00476, 00810
Jerrold	00476, 00810
Motorola	00476, 00810, 01106, 01187, 01376
Nokia	01569
Pace	00237, 01877
Pioneer	00877, 01877
RCA	01256
Scientific Atlanta	00877, 01877
Sony	01006
Supercable	00276
Thomson	01256

Zenith 00899

DBS/PVR Combination ※ 1

@sat 01300

Atsat 01300

British Sky Broadcasting
01175

Canal Satellite 01339

Comag 01412

Digiturk 01076

DirecTV 00099, 00392, 00639, 01076, 01142, 01377,
01392, 01442, 01443, 01444, 01640

Dish Network System
00775, 01505

Dishpro 00775, 01505

Dream Multimedia 01237

Echostar 00610, 00775, 01170, 01505

Euro1 01278

Expressvu 00775

Force 01194

Foxtel 01356

GbSAT 01214

Grundig 01150

Hughes Network Systems
01142, 01442, 01443, 01444

Humax 01176, 01427, 01568

Hyundai 01159

JVC 01170

Kathrein 01221, 01561

Maximum 01334

Motorola 00869

Nokia 01310, 01311

Opentel 01412

Pace 01423, 01623

Panasonic 01320

Philips 00099, 01142, 01442

Proscan 00392

RCA 01392

Rebox 01214

Sagem 01253, 01307

Samsung 01442

SKY 01175, 01848

Skyplus 01412

Sony 00639, 01640

Star Choice 00869

Strong 01158, 01300

Thomson 01900

Topfield 01206, 01545

TPS 01253, 01307

Zehnder 01075, 01412

- ※ 1 : These preset codes can be recorded in the SAT/CBL mode.
: Ces codes de présélection peuvent être enregistrés en mode SAT/CBL.
- ※ 2 : These preset codes can be recorded in the DVD mode.
: Ces codes de présélection peuvent être enregistrés en mode DVD.
- ※ 3 : These preset codes can be recorded in the TV mode.
: Ces codes de présélection peuvent être enregistrés en mode TV.
- ※ 4 : This preset code can be recorded in the VCR mode.
: Ces codes de présélection peuvent être enregistrés en mode VCR.
- [] : Preset codes set upon shipment from the factory.
: Les codes pré-réglés diffèrent en fonction des livraisons de l'usine.

DVD preset codes / Codes pré-réglés DVD			
		41470 (default / défaut)	40490
DENON Model No. / Modèle numéro	DVD-555	DVD-2910	DVD-800
	DVD-755	DVD-3800	DVD-1600
	DVD-900	DVD-3910	DVD-2000
	DVD-910	DVD-5900	DVD-2500
	DVD-955	DVD-5910	DVD-3000
	DVD-1000	DVD-9000	DVD-3300
	DVD-1200	DVM-715	
	DVD-1500	DVM-1800	
	DVD-1710	DVM-1805	
	DVD-1910	DVM-1815	
	DVD-2200	DVM-2815	
	DVD-2800	DVM-4800	
	DVD-2800II		
	DVD-2900		







DENON

TOKYO, JAPAN
www.denon.com

Denon Brand Company, D&M Holdings Inc.
Printed in Japan 00D 511 4483 000

