

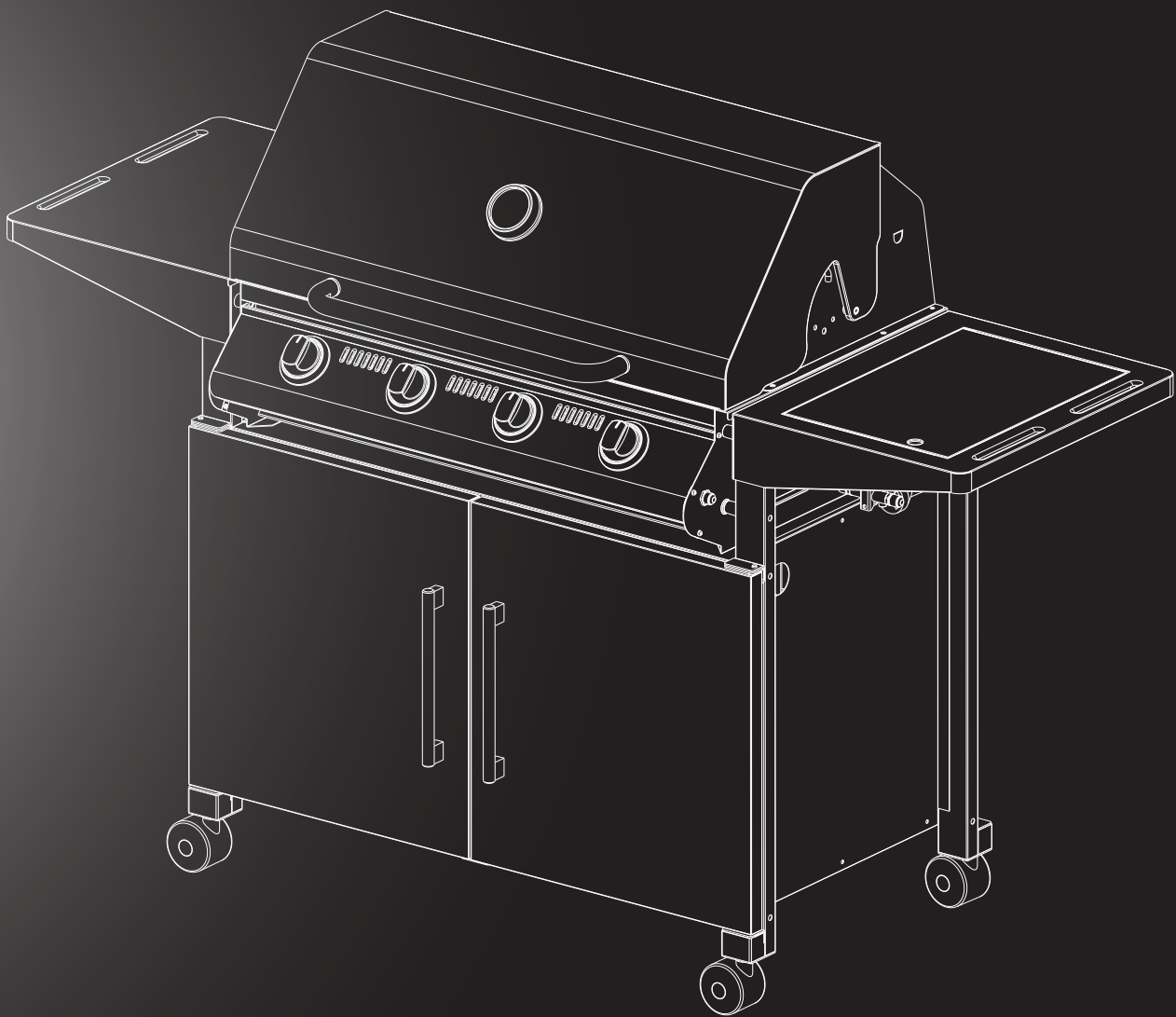

Assembly and Operating Instructions

DISCOVERY 1000E SERIES



FOR OUTDOOR USE ONLY

AUSTRALIA / NEW ZEALAND

Dear customer,

Congratulations and thank you for choosing our barbecue. We are sure you will find it a pleasure to use. Before you use the barbecue, we recommend that you read through the relevant sections of this manual, which provide a description of your appliance and its functions.

To avoid the risks that are always present when you use an appliance, it is important that the appliance is installed correctly and that you read the safety instructions carefully to avoid misuse and hazards.

We recommend that you keep this instruction booklet for future reference and pass it on to any future owners.

After unpacking the appliance, please check it is not damaged. If in doubt, do not use the appliance but contact your local customer care centre.

This appliance complies with requirements of Australian Standards AS5263.

Conditions of use

These important notes apply to your appliance, failure to adhere to these conditions of use may affect your ability to make a claim under the manufacture's warranty.

- This appliance must be serviced only by a qualified licenced person.
- This product is intended for personal, domestic or household use only, not commercial use.
- This product is intended for outdoor use only.
- This product must be installed, operated and maintained as per the instructions.
- Ventilation holes in the unit must not be obscured by the installation.

Please ensure you read the instruction manual fully before you call for service, or a full service fee could be applicable.

Record model and serial number here:

Model number:

Serial number:.....

PNC:.....

Important safety instructions.....	3
Gas cylinder safety information	6
Know your barbecue.....	7
Contents.....	8
Trolley assembly	9
Natural gas conversion	12
Using your barbecue	13
Technical information.....	15
Locating your barbecue.....	16
Installing your barbecue	17
Cleaning and storing your barbecue	18
Maintenance	19
Troubleshooting	20
Notes.....	21
Warranty	23

Please read the user manual carefully and store in a handy place for later reference.

The symbols you will see in this booklet have these meanings:



WARNING

This symbol indicates information concerning your personal safety.



CAUTION

This symbol indicates information on how to avoid damaging the appliance.



IMPORTANT

This symbol indicates tips and information about use of the appliance.



ENVIRONMENT

This symbol indicates tips and information about economical and ecological use of the appliance.

Please read the user manual carefully and store in a handy place for later reference.



IMPORTANT

Important – check for any damages or marks

If you find the barbecue is damaged or marked, you must report it within 7 days if you wish to claim for damage/marks under the manufacturer's warranty. This does not affect your statutory rights.



ENVIRONMENT

Information on disposal for users

- Most of the packing materials are recyclable. Please dispose of those materials through your local recycling depot or by placing them in appropriate collection containers.
- If you wish to discard this product, please contact your local authorities and ask for the correct method of disposal.



WARNING

This appliance must be serviced only by a qualified licensed person.

Improper installation, adjustment, alteration or maintenance can cause injury or property damage and may affect your ability to claim under the manufacturer's warranty.

Please contact your nearest BeefEater Service Department for additional information or assistance for an approved installer.

Note to the installer

This manual must remain with the owner for future reference.



WARNING

- Do not lean over barbecue when lighting.
- Do not leave the barbecue unattended when alight.
- Do not delay lighting once the gas has been turned on.
- Do not store or use aerosol cans in the vicinity of the barbecue.
- Do not store flammable liquids in the vicinity of the barbecue.
- Do not use caustic or abrasive based cleaners on the barbecue.
- Do not attempt to dismantle or adjust the control valves.
- Do not attempt to dismantle or adjust the regulator.
- Do not test for leaks with a naked flame.
- Do not modify the construction of this appliance or modify the injector orifice size.

- Do not obstruct any ventilation of the barbecue.
- Do not allow children to operate or play near the barbecue.

Failure to adhere to the above warnings may cause injury or property damage and affect your ability to make a claim under the manufacturer's warranty.



CAUTION

This appliance is set up for Universal LPG and is labelled accordingly. A natural gas conversion kit is available if required. Conversion of this unit to natural gas must be carried out by a qualified licensed person and a Certificate of Compliance must be issued to the owner at the completion of the installation and conversion.



IMPORTANT

BeefEater Barbecues are approved for OUTDOOR USE ONLY and must not be used in a building, garage or any other enclosed area.

- BeefEater Barbecues must not be used inside recreational vehicles or boats.
- Read instructions thoroughly before operating this Barbecue.
- Save this manual for future reference.
- Always use the Barbecue on a flat, level surface.
- Some foods produce flammable fats and juices. Regular cleaning is essential.
- Attend an operating barbecue at all times. Damage caused by fat & grease fires is not covered by warranty.
- When not in use keep Barbecue dry and covered.



WARNING

If you smell gas:

1. Shut off gas to the appliance.
2. Extinguish any open flame.
3. Open hood.
4. If odour continues, immediately call your gas supplier or your fire department.

For your safety

1. Do not store or use gasoline or other flammable vapours or liquids in the vicinity of this or any other appliance.
2. An LPG cylinder not connected for use shall not be stored in the vicinity of this or any other appliance.

IMPORTANT SAFETY INSTRUCTIONS



WARNING

Failure to follow these instructions and observe the warnings provided in this operations manual could result in fire, explosion or burn hazard, which could cause property damage, personal injury or death.

Gas vapour is highly explosive and can cause serious bodily injury or damage to property if allowed to accumulate in a confined space and ignited.

This appliance must not be installed under or on any combustible material. Minimum clearance from combustible materials to all sides of the appliance is 450mm (18").

These instructions must be left with the owner.

NOTE:

1. Do not use gas other than the type specified on the Data Plate.
2. The appliance is designed for use by adults, keep children away from the barbecue at all times.
3. Use only on a flat, level, stable non-combustible surface. Do not use this appliance on any surface that can burn or melt.
4. When in use, gas cylinder should be kept at designated mountings of barbecue, and supply hoses kept away from any hot surfaces.
5. To prevent accidental fires, before using the appliance ensure that there is no apparent damage to hose and regulator and all joint connections are in good order and not leaking.
6. Use a soapy water solution on all joints in order to check for leaks. If bubbles appear, it indicates that there is a leak and the appliance must not be used.
7. LPG cylinder, regulator and hose must comply with national standards.
8. Do not move or attempt to move the appliance while in operation.
9. Do not operate this appliance before leak checking hoses and gas cylinder connection.

To the installer

- For fixed installations, in Australia refer also to the requirements of AS/NZS5601, local authority, gas, electricity, and any other relevant statutory regulations.
- For fixed installations, refer to AS/NZS5601 for pipe sizing details.
- Consult other trades. Where required, consult a bricklayer or an electrician for parts of the installation that could have an effect on these areas.
- Allow a 20mm gap from back of barbecue body for ventilation and air access.
- Test appliance for correct operation before leaving, and instruct user on its use.
- If correct operation cannot be achieved, disconnect barbecue from gas supply, and contact your nearest BeefEater dealer.
- Please only use BeefEater supplied hose(s) to connect this appliance. Natural Gas conversion kits are available from your nearest BeefEater dealer.
- Australia only (applies to all gas types) : Where a mobile appliance is to be connected to a fixed gas supply via a flexible hose connection, a retaining tether of adequate strength shall be fixed to the appliance and be suitable to be fixed to the wall within 50mm of each connection point. The length of the tether shall not exceed 80% of the length of the hose assembly. In this way, if the barbecue is accidentally moved, the tether stops the barbecue from stretching the hose.

Do not

- Lean over barbecue when lighting.
- Leave cooking food unattended.
- Delay lighting burners after turning gas on.
- Spray or store aerosols in vicinity of barbecue whilst in operation.
- Place articles on or against this appliance
- Store combustible materials, gasoline or flammable liquids or vapours within 450mm (18") of barbecue.
- Use caustic based cleaning agents on the barbecue.
- Operate barbecue with any cover on.
- Use plastic or glass utensils on the barbecue.
- Operate barbecue in strong winds.
- Attempt to dismantle control valves.
- Attempt to dismantle or adjust regulator.
- Test for gas leaks with a naked flame.
- Store gas cylinder indoors, or in any enclosed area.
- Lay the gas cylinder down. Always keep it upright.
- Use barbecue indoors.
- Expose hose to direct sunlight.
- Modify the construction of this appliance or the size of any burner or valve orifice.

- Move the appliance during use.
- Obstruct any ventilation of barbecue or the cylinder.
- Allow the flexible gas supply hose or any electrical cord to come in contact with hot surface of the appliance.
- Allow children to operate this appliance.
- Use charcoal or any other solid fuel in this appliance.
- Disconnect any gas fittings while the appliance is operating.
- Use a rusty or dented gas cylinder or cylinder with a damaged gas valve.
- Fill the gas cylinder beyond 80% capacity.
- Touch some accessible parts, other than the ones meant for handling. They may be hot.

Do

- Spanner tighten all gas fittings as per instructions.
- Check all gas hoses and line connections for damage, cuts or cracks each time the appliance is about to be used.
- Always leak test with a solution of soapy water.
- Check main opening, throat and venturi to each burner and pilot flame tube regularly for insect nests (eg. wasp, ants or spiders). Nests are dangerous and must be cleaned out thoroughly.
- Visually check burner flames to confirm lighting.
- Use your barbecue only on a level surface.
- Attend barbecue whilst cooking food.
- Preheat the barbecue for up to 10 minutes.
- After cooking turn barbecue to high for up to 10 minutes to burn off excess grease.
- Let the barbecue cool before replacing any lid or cover.
- Regularly replace foil material in grease/drip tray.
- Keep children away from barbecue at all times.
- Have the gas cylinder filled by an authorised LPG supplier.
- Refer to this instruction manual if in doubt concerning assembly, installation, or operation.
- Use protective gloves when handling hot components.
- Close the gas cylinder valve after each use.
- Clean the grease/drip tray regularly and clean the appliance at least twice annually.
- Always remove any lid or cover off the appliance before lighting.
- Carefully follow the instructions relating to the hose/regulator connection.
- Keep the barbecue area free from combustible materials, gasoline, flammable liquids or vapours.

IMPORTANT

Should the appliance go out for any reason, turn off all control knobs and the cylinder gas valve. Wait 5 minutes before attempting to relight the appliance.

- If a grease or fat fire should occur, immediately turn off all control knobs and the gas cylinder valve until the fire is out. Remove all food from the appliance.
- A leak test must be carried out prior to using the appliance for the first time and whenever the gas cylinder is refilled or whenever the gas hose and regulator have been disconnected from the gas cylinder or appliance.

GAS CYLINDER SAFETY INFORMATION

Gas cylinders must be stored outdoors, out of reach of children and must not be stored in a building, garage or any other enclosed area.

- This appliance is designed to be used with a gas cylinder not exceeding 9KG (20lbs) capacity.
- The Gas cylinder must be constructed and marked in accordance with specifications for LP Gas Cylinders.
- Ensure gas cylinder is within the expiration date, it is not advised to use or attempt to refill a gas cylinder that is outside of its expiration date.
- The gas cylinder supply valve must be turned off when the appliance is not in use.
- The gas cylinder used must incorporate a safety collar to protect the valve assembly.
- The gas cylinder must always be kept and used in the upright position.



IMPORTANT

When disconnecting and removing the gas cylinder for the purpose of refilling, always observe the following procedure:

- Ensure that all gas control valves on the appliance and the gas cylinder are turned off before disconnecting the gas line from the cylinder.
- Do not smoke or use a naked flame near the appliance or gas cylinder while disconnecting the gas line between the appliance and gas cylinder.
- Remove the gas cylinder from the enclosure before disconnecting the gas line from the appliance.
- Tighten all connections before placing the gas cylinder back in its enclosure.

The Gas Leak Testing Procedure should be conducted every time the gas cylinder is refilled and reconnected to the appliance – before using the appliance.

Regulator Connection

1. Check that all control knobs are in the 'Off' position.
2. Make sure the cylinder valve is off by turning the valve knob all the way clockwise.
3. Remove the protective cap from the cylinder if present.
4. Make connection as described in figures 1 and 2.
5. Leak-test the connection with a soapy water solution. [See Gas Leak Testing Procedure].

Hose and regulator replacement must be a genuine part specified for this appliance and is obtainable from your nearest BeefEater stockist.

FIG 1

Standard POL regulator

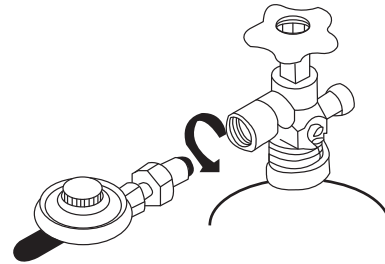
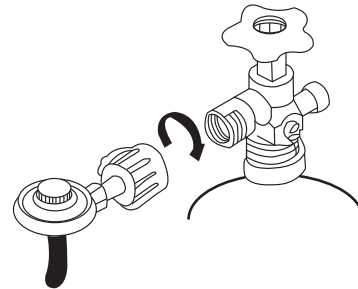

FIG 2

Quick connect regulator



Gas Leak Test Procedure

Use the following procedure to check for gas leaks. Never use a naked flame to check for gas leaks.

1. In a small container, mix up a solution of water and detergent or soap. Mix the solution well.
2. Make sure that the gas supply valve on the gas cylinder is turned on.
3. Make sure that the gas control valves on the appliance are all turned off.
4. Using a brush or spray bottle apply the solution to the gas line and each join in the gas line. See Fig 3.
5. Bubbling of the solution will indicate that there is a leak present.
6. Re-tighten or re-seal any joints that are leaking.
7. If a leak persists then contact your distributor or the manufacturer for assistance.

FIG 3

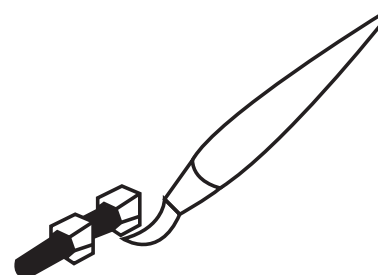

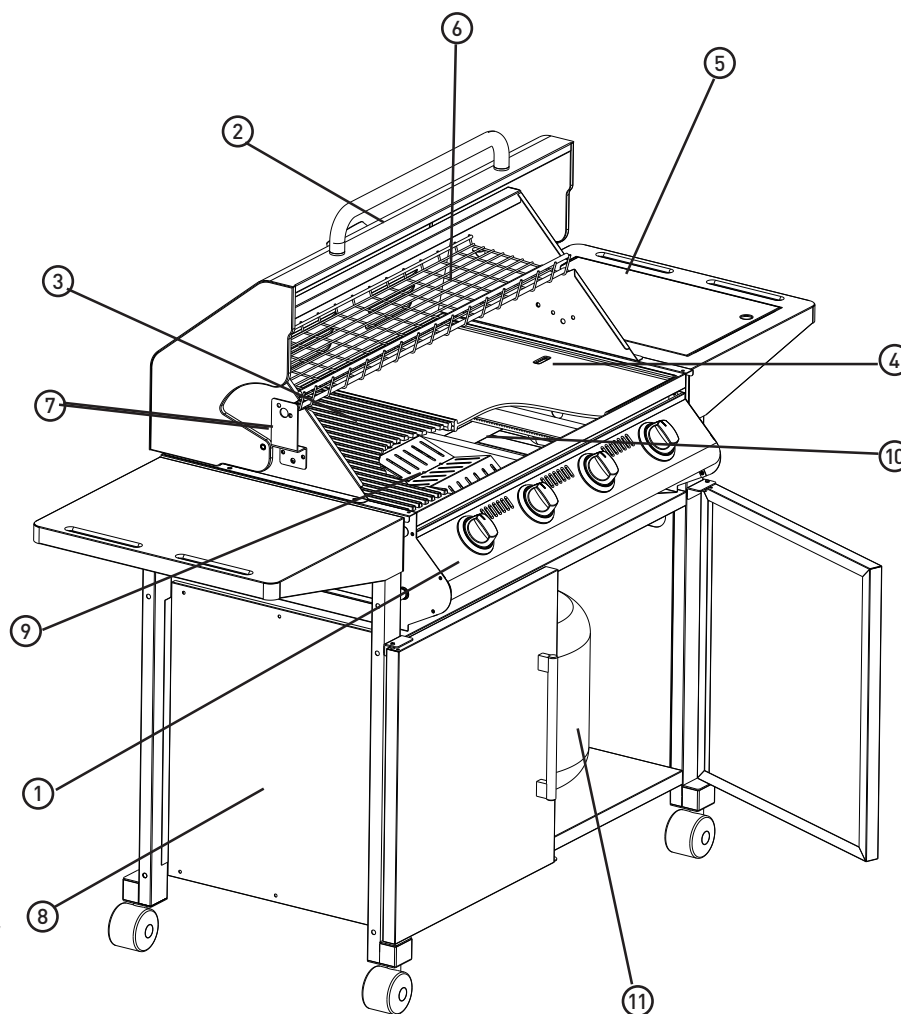

- ① Barbecue Body
- ② Hood
- ③ Cooking Grill
- ④ Cooking Plate
- ⑤ Side Burner
- ⑥ Warming Rack
- ⑦ Rotisserie Bracket**
- ⑧ Cabinet Trolley*
- ⑨ Vaporizers
- ⑩ Burner
- ⑪ Gas Cylinder (sold separately)

* Trolley is packed in a separate carton
 ** Rotisserie is sold separately.

CONTENTS

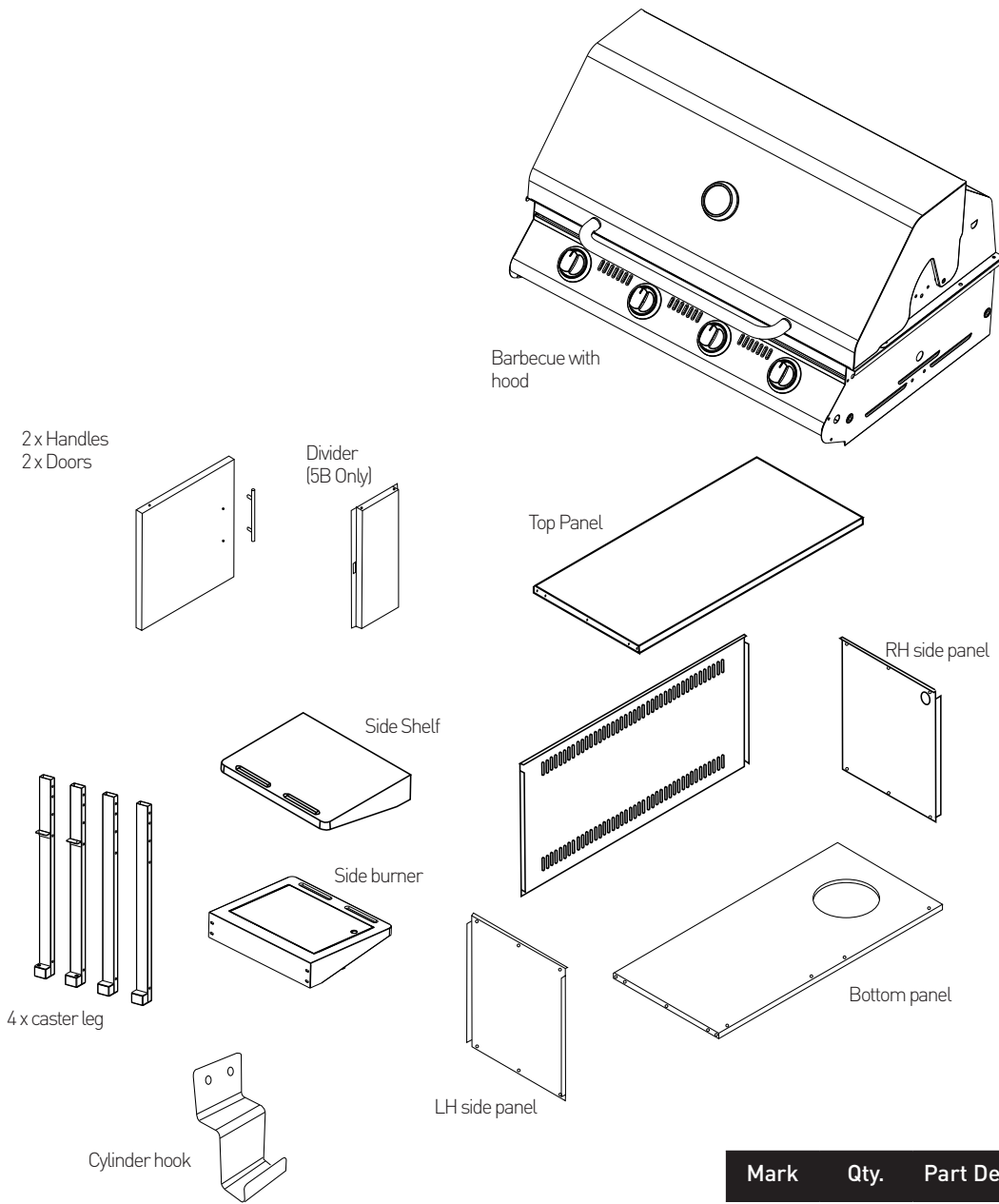

Mark	Qty.	Part Description
A	8	Phenolic Spacers
B	2	Magnets
C	8	M6 x 85mm screw
D	12	M6 x 60mm screw
E	4	M6 x 12mm screw
F	38	M6 Washer
G	14	M6 Nut
H	20	Fat tray M4 x 10mm screw
I	20	M4 Nut
J	40	M4 washer
K	4	Door Handle screws

Tools Required for Assembly:



Phillips Head Screwdriver

Step 1

8 x 'A', 8 x 'C', 4 x 'D', 16 x 'F', 4 x 'G'

Remove all loose parts from inside barbecue, and lay upside down.

Attach 4 legs, shelf and side burner.

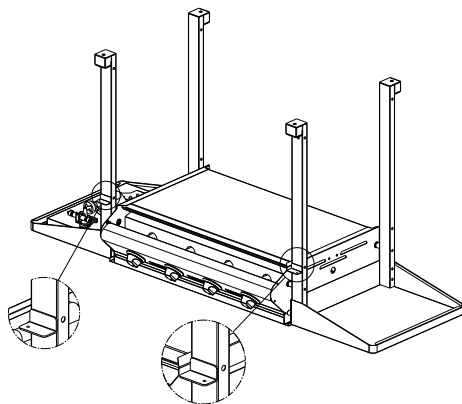

NOTE: Ensure correct placement of leg posts for door hinge.

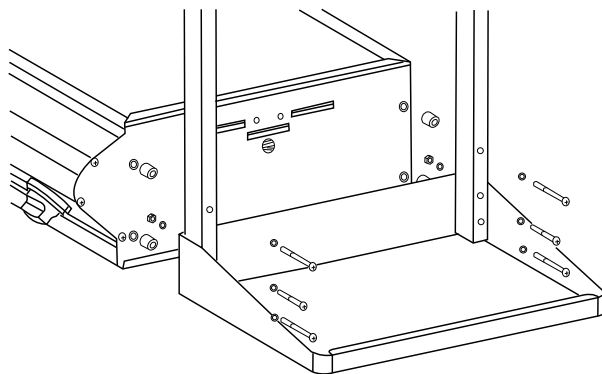

Step 2

4 x 'D', 8 x 'F', 4 x 'G'

Ensure magnet attached to the top panel (except for 5 Burners).

Assemble the panel in between the 4 legs.

Ensure the fold with the magnet is facing up and front.

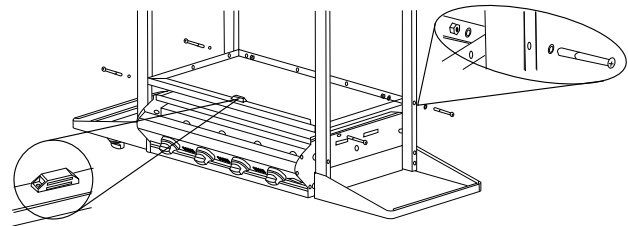

Step 3

6 x 'H', 6 x 'I', 12 x 'J'

Attach the side panels. Ensure the one with the hole for hose is on the right, hole on top (when upright).

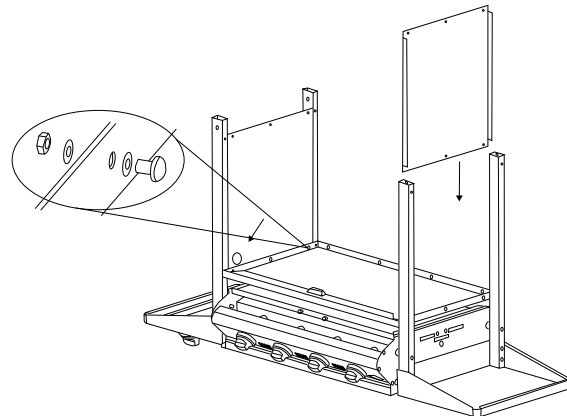

Step 4

6 x 'H', 6 x 'I', 12 x 'J'

Insert the back panel in place and attach to top panel.

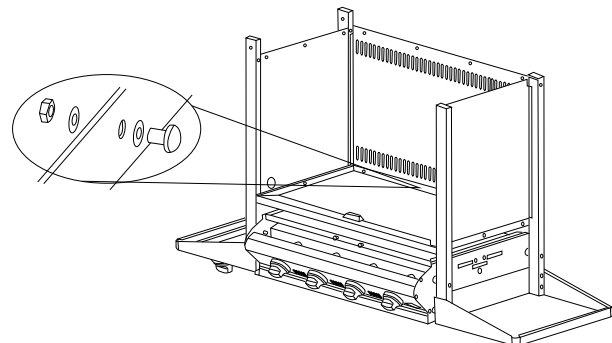

TROLLEY ASSEMBLY

Step 5

4 x 'D', 8 x 'F', 4 x 'G', 10 x 'H', 10 x 'I', 20 x 'J'

Verify magnet is in place (except for 5 Burners), and attach the bottom panel. Ensure the folds are facing up, and the magnet down and to front.

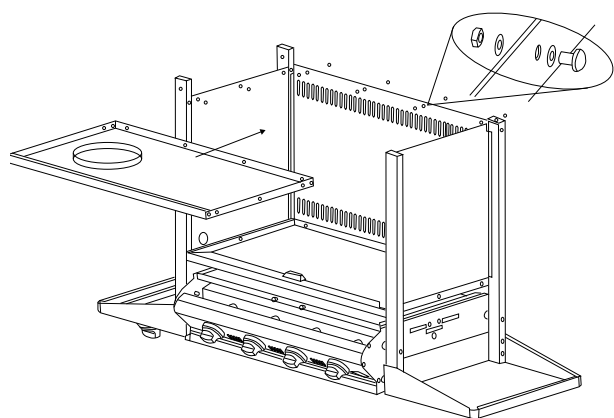

Step 6

Attach Castors to legs

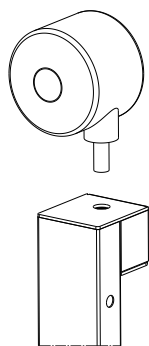

Step 7 (5 Burners Only)

2 x 'E', 2 x 'F'

Fit the 2 magnets into the rectangular slots in the separating panel, and then fit panel in front centre, between the 2 doors.

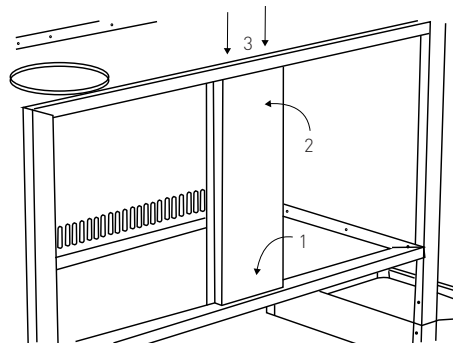

Step 8

4 x 'K'

Turn the assembled barbecue upright, attach handles to doors, insert the hinge rod to the door, and assemble doors to trolley.

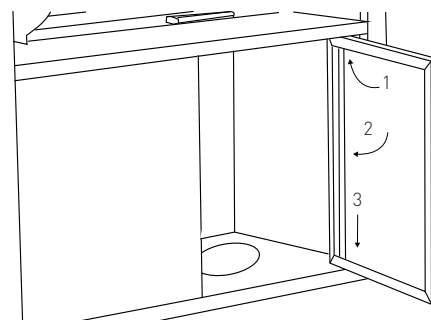

Step 9

2 x 'E', 4 x 'F', 2 x 'G'

Attach the Cylinder-Hook on right hand side of BBQ.

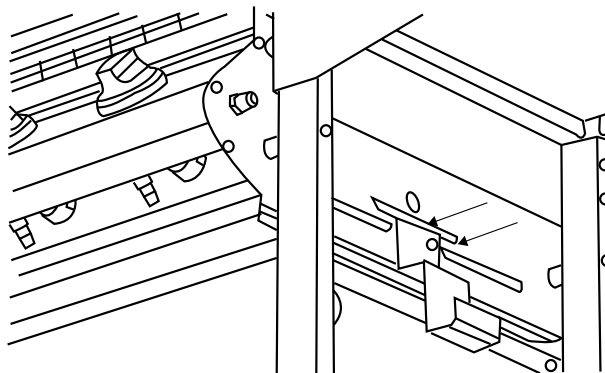

Step 10

Connect barbecue to the cylinder and carry out a leak-test.

Refer to Leak Testing Procedure on page 6.

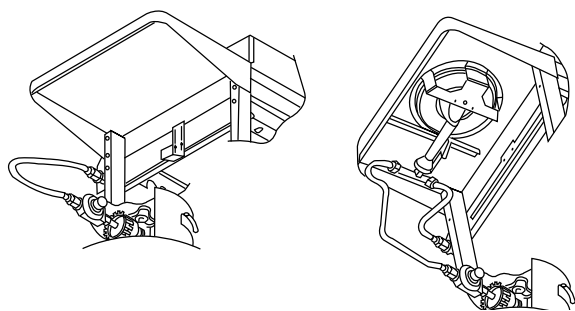

NOTE: When in operation, keep 450mm (18") clearances from combustible materials.

General

This barbecue is to be mounted onto a mobile trolley.

The Trolley is packed in a separate carton. Please refer to the Trolley instruction booklet for assembly of the trolley, and barbecue mounting.

Once the barbecue had been properly installed on the trolley, please check the following:

1. Hood is secured by 4 screws to barbecue's body, and operating correctly.
2. All burners are in place correctly.

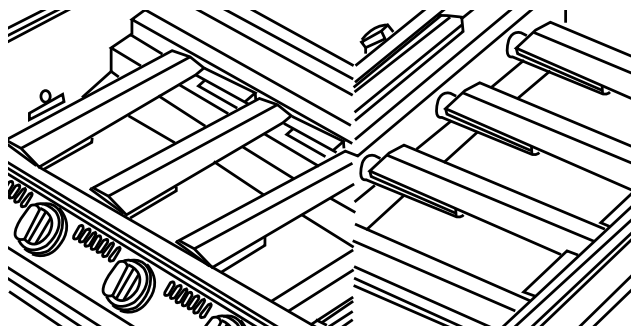

3. Vaporizers are installed above burners, but under the Grill (not required under the Plate).

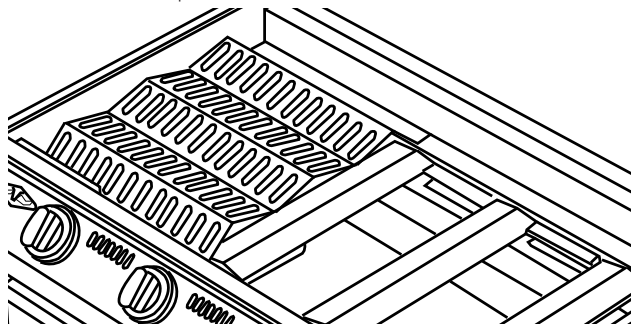

4. Cooking surfaces (Grill and Plate) are clean, and installed over the burners.

NATURAL GAS CONVERSION

Natural gas installation

NOTE: Conversion of this unit to natural gas must be carried out by a qualified licenced person and a Certificate of Compliance must be issued to the owner on completion of the installation conversion.

Converting to natural gas (to the installer)

This barbecue is supplied set up for Universal LPG and is labelled accordingly. A natural gas conversion kit is available as an accessory by contacting Electrolux customer service.

1 x Natural gas hose and regulator assembly with quick connect bayonet fitting.

1 x bag containing:

5 x 45° valve with 1.90mm injectors

1 x 90° valve with 1.80mm injector

1 x Natural gas label

Procedure

1. Remove knobs and for each bezel remove 2 screws retaining the bezel to the valve.

2. At each end of the control panel, remove 3 screws retaining the control panel.

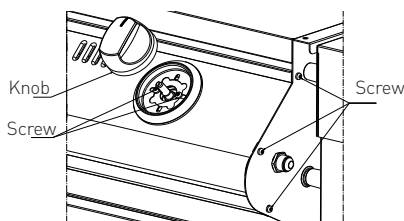

3. Remove control panel to access the valves

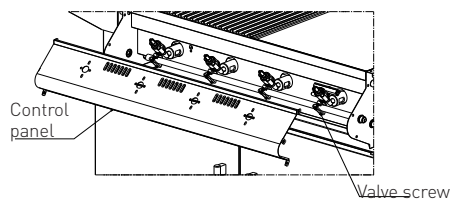

4. Remove each valve and replace with valve provided in the natural gas conversion kit, note the injector size, as shown on page 14.

5. Remove the hose and regulator assembly, and replace the hose and regulator appropriate for the intended gas supply.

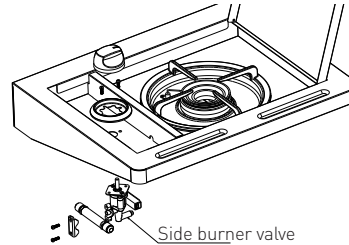

6. Turn on gas & check for leaks at every connection (use soap solution to identify leaks.)

7. Replace the control panel, bezels and the knobs.

8. Check and adjust if necessary the supply pressure is 1.13kPa.

9. The operation of the regulator can be confirmed by connecting a manometer to the test point located on the side of the regulator body. With three burners operating at maximum the outlet pressure should measure 1.0kPa.

Before you light the Barbecue

Perform the following checks:

- Make sure all connections are tight, and leak-tested. Gas regulators fitted with a hand-tightened wheel must be checked to ensure they are secured.
- Check that all control knobs are in the 'Off' position, and that gas supply is turned off.
- Ensure that the Hood on the barbecue, and the Lid on the side-burner are open. If lids are closed there is a risk of gas accumulating inside, and creating a dangerous situation.
- The hose and regulator supplied with this barbecue must be used at all times whilst operating this barbecue. Inspect the hose and regulator regularly for cracks or any sign of damage. If there is excessive abrasion or wear, replace only with a genuine BeefEater regulator.

Grease Tray

Neatly line the grease tray with some aluminium foil sheeting to aid in clean up. Cut the foil to shape, and make sure it sits on the bottom of the tray.

Fill the tray with 6mm (1/4") layer of dry sand or other non-combustible absorbent material to absorb grease. Change the foil and absorbent material regularly to reduce the likelihood of grease tray fire.

Lighting the Barbecue

Ensure the appliance is placed on a flat, level, non-combustible surface.

- Ensure the regulator is connected to the LPG cylinder (See Regulator Connection page 4.), and the hose is not subject to any twisting, and is not close to hot surfaces.
- Verify all joints are spanner tight and check for leaks after turning on gas supply. See correct procedure on page 4.
- Ensure all knobs are in the 'Off' position.
- Ensure cooking plate and grill are in place.
- Open Gas Cylinder valve

NOTE: The barbecue is fitted with a safety feature that prevents the burners from being accidentally turned on. You must push the knob inwards to disengage the lock, and only then start turning it.

Light each burner by following this procedure:

- Read all instructions before lighting.
- Open Hood before lighting.
- Push in and turn Right-Hand-Side knob counter-clockwise to 'High'.
- If ignition does not occur, return to 'Off' and repeat after 5 minutes.

Check for a clear blue flame with just a tip of yellow.

Once the right-hand-side burner is alight, light each successive burner from right to left.

WARNING

Excess yellow tipping means the combustion is not right, if that is observed, turn the Barbecue burners off, and refer to troubleshooting at the end of this manual.

Do not use more than 2 burners on 'High' with the hood closed.

If the burner does not light

Keep the control knob pushed, and return the knob in the clockwise direction to the 'Off' position. Wait 5 minutes, and repeat the lighting procedure steps 1 – 4 above again. If after a few attempts you still can not light the burners, contact your retailer before proceeding.

Manual Lighting

Press and turn the right hand control knob anti-clockwise to the 'High' position, then light the right hand burner immediately through a hole provided in the middle of the right hand barbecue side panel.

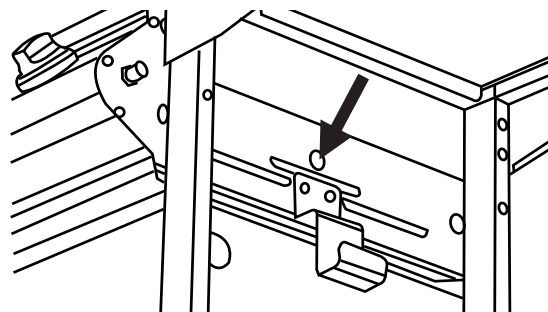

Check for proper burner operation

Following operating instructions light each burner and check for a clear blue flame with just a tip of yellow. Excess yellow tipping can be adjusted using the screw on the side of the burner. If you are unable to achieve correct operation, consult your dealer.

Preparing the Plate and Grill

Your barbecue has heavy duty enamelled Cast Iron plate and grill. Enamel is a hard, non-rusting surface which will ensure the long life of your cooking surface.

The plate and grill are ready to use, but it is recommended to wash them with warm soapy water and a soft cloth, and rinse before use.

To ensure the longevity of the enamel surface on the Cast Iron plate and grill it is strongly advised to avoid impact with other metal parts and sharp utensils.

To turn off a burner

Simply turn the knob (without pushing) clockwise to the 'Off' position.

USING YOUR BARBECUE

After Use

It is a good idea to leave the barbecue on for about 10 minutes after you have finished cooking. This helps to burn away any excess food residues and oil, and makes cleaning easier.

1. Be sure to turn off all control knobs and the gas supply.
2. Allow the barbecue to cool.
3. Clean the drip tray and cooking surfaces. Clean any food spills from the side burner, if one is installed.
4. Lower the hood and side burner lid.

The gas cylinder supply valve must be turned off when the appliance is not in use.

Direct Cooking Method

Commonly used for traditional barbecuing. Place food over the lit grill section. Some flaring may occur, so care must be taken while cooking. Check inside the roasting hood regularly. The direct cooking method is recommended for steaks, chops, sausages, and hamburgers.

Indirect Cooking

Indirect cooking involves little or no heat directly underneath the food. Instead, the food is placed on the grill, the burners below the food are turned off or Low, and burners on either side are used. The hood is closed to trap heat and moisture. With this method, heat circulates around the food, cooking by convection. By trapping the vapour inside your "outdoor oven", the cooking vapour will fall back on the food on all sides, not just from underneath. The food cooks more evenly, and stays moist in the process. Indirect cooking is similar to using a conventional oven and is recommended for rotisserie cooking, roasts, poultry, casseroles, vegetables and whole fish. When cooking a roast, it is a good idea to use a roast holder and baking dish. Always use a baking dish with a depth greater than 35mm. Shallower trays may fill quickly and overflow, which may cause a fat fire.

Controlling the Burners

The control knob can now be turned to the desired heat setting, Low, High or anywhere in between. The control knob does not need to be pushed in while selecting the heat setting.

Operating the side Side Burner

Do not use oversized cookware or place cookware off-centre over the burner as this can cause high temperatures in control knob and surrounding panels. Cookware should not exceed 200mm in diameter, the use of larger cookware may cause damage to the appliance and is not covered under warranty.

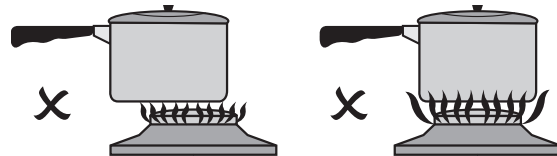

Incorrect - pan not centred.

Incorrect - flame too high

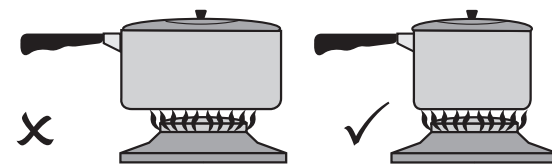

Incorrect - pan too large

Correct

GAS	Injectors MM	BARBECUE		SIDE BURNER		PRESSURE kPa
		Total gas consumption (MJ/h) 4 Burner	5 Burner	Injectors MM	Total gas consumption (MJ/h)	
Universal LPG	1.10	60	75	1.10	16.0	2.75
Natural gas	1.80	60	75	1.80	15.0	1.00

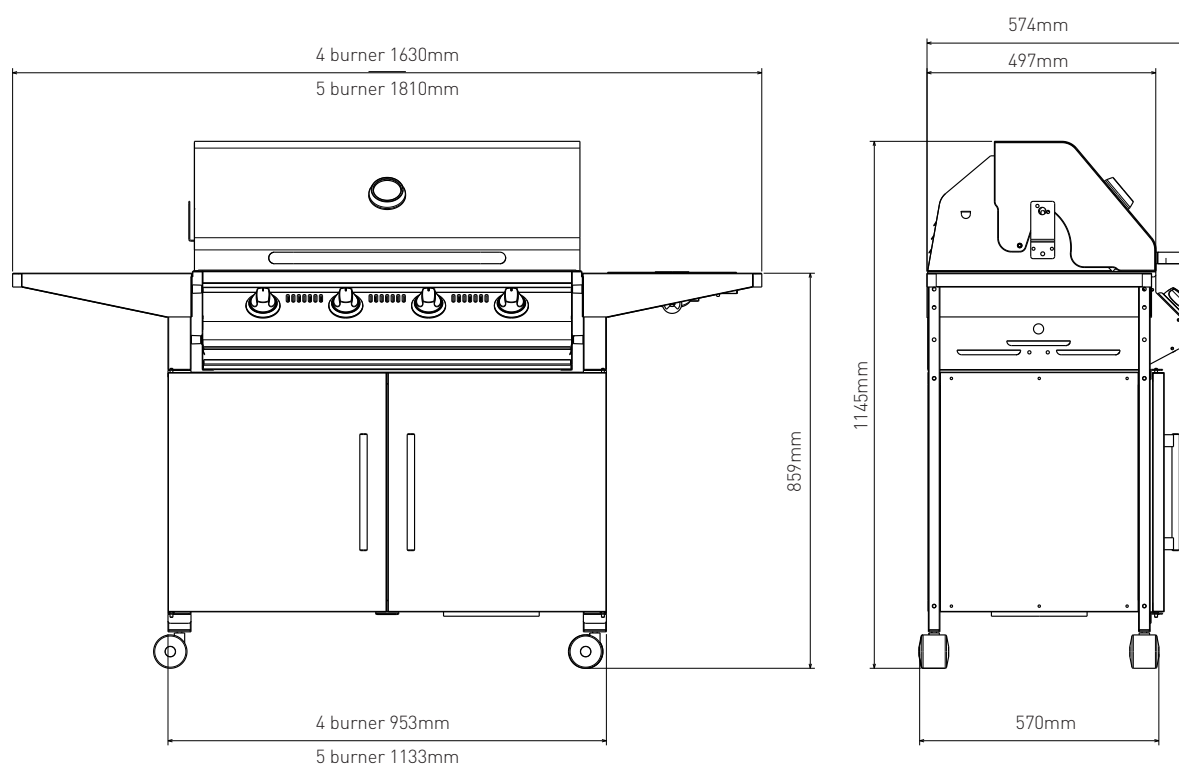

LOCATING YOUR BARBECUE

Most importantly, this is an outdoor appliance. Ensure your barbecue is positioned safely away from anything that can catch fire.

Outdoors Use Only

Under no circumstances is this barbecue to be used indoors. This includes garages or any other enclosed area.

Clearance from Combustibles: Ensure your barbecue remains at a distance of at least 45 cm (18") from any combustible material such as wood, gyprock, paper and plants. Do not store combustible materials, gasoline or flammable liquids or vapours within 45 cm (18") of the barbecue.

Adequate Ventilation

Ensure there is adequate ventilation for both the barbecue and cylinder. This is required not only for proper combustion, but also to prevent gas build up.

20mm ventilation and air-intake gap is to be left at rear of the barbecue in fixed installations.

Firm Level Surface

Use your barbecue only on a firm level surface. This barbecue is not designed for recreational vehicles, and shall not be installed on a boat or any marine craft.

Protection From Weather: Keep the barbecue protected from adverse weather, including rain and high winds.

Polyvinyl covers are available that have been specially designed for this range of barbecues. Allow clear access to the entire gas supply hose and regulator.

Maintenance Access: When your barbecue is installed, you should be able to access the gas supply line including the gas piping or hose, gas regulator, gas cylinder and any shut off valves.

Partial Enclosures: Many backyards have areas that are partially closed off, such as balconies and pergolas. In some cases, it is hard to decide whether these partially enclosed areas should be classified as indoor areas. This manual provides clear definition of such areas in page 10 for your reference.

Connect the Regulator to the gas Cylinder



WARNING

Verify 'Gas Type' label & data plate attached to side of barbecue is correct for the gas you are about to connect to.

The hose and regulator is connected to the barbecue and leak tested at factory. Do not disassemble unnecessarily.

1. Make sure burner valves are in the 'Off' position.
2. Screw regulator side to the cylinder, and hand-tighten. See more details on page 4.

NOTE: Do not modify this appliance. Any deviation from the factory settings could result in a safety hazard.

- If moving the barbecue from one place to another, never drag the cylinder behind. Disconnect the cylinder first, move, and re-connect once reached the new location.
- For storage and cylinder exchange, disconnect hose at the cylinder only, do not disconnect hose from the appliance.
- If you have purchased a trolley with a Side-Burner, please refer to Trolley instruction book for correct connection of the Side-Burner to the gas supply.

INSTALLATION OPTIONS

Partial Enclosures (Australia Only)

This appliance shall only be used in an above ground, open air situation with natural ventilation, without stagnant areas, where gas leakage and products of combustion are rapidly dispersed by wind and natural convection. Any enclosure in which the appliance is used shall comply with one of the following:

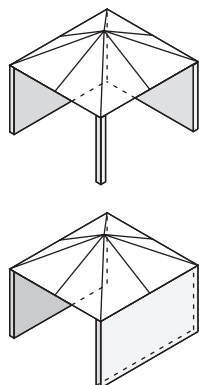

Within a partial enclosure that includes an overhead cover and no more than two walls.

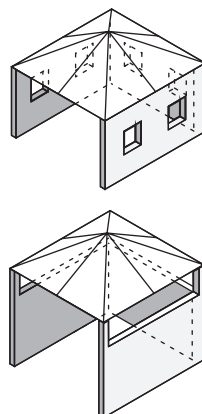

Within a partial enclosure that includes an overhead cover and more than two walls, the following shall apply:

- At least 25% of the total wall area is completely open; and
- at least 30% of the remaining wall area is open and unrestricted.

In the case of balconies, at least 20% of the total of the side, back and front wall areas shall be and remain open and unrestricted.

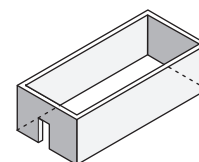

Any enclosure with walls on all sides, but at least one permanent opening at ground level, and no overhead cover.

Before proceeding, you need to establish the gas type which your barbecue will run on, and the style of installation you need.

Natural Gas or LPG/Propane.

Before beginning installation or assembly, check that the gas type which the barbecue is designed for is correct for the gas available to you. In most countries the choices are natural gas or LPG/propane. You will find the gas type label on the side of your barbecue. If your barbecue uses the incorrect gas type, or if you are unsure, consult your dealer before going any further. Using the wrong type of gas for a barbecue is extremely dangerous.

Natural Gas Conversion

Most newly purchased barbecues are made for LPG/propane. A natural gas conversion kit is available to allow your barbecue to run on Natural Gas. This kit includes all hoses required for installation

CLEANING AND STORING YOUR BARBECUE

Cleaning Vitreous Enamel Surfaces and Barbecue Control Panel

Although porcelain enamel will keep its lustrous finish even under adverse conditions, it still needs regular cleaning. After the appliance has been used, wash down the surfaces with hot soapy water. Caustic cleaners should be avoided. For barbecues near the ocean or salt-water environment, more frequent cleaning and servicing should be conducted. Wash regularly, rinse and then dry before covering. (In a salt water or marine environment, more rapid deterioration can be expected which is not covered by warranty).

The cleaning and care instructions are essential for the proper functioning and operation of your appliance over time. Failure to adhere to these care instructions may affect your ability to make a claim under the manufacturer's warranty.

Cleaning Plates and Grills

Many food acids, marinades, juices and sauces contain highly acidic elements that will slowly attack the surface of the plates and grills if not removed after cooking.

- After use, remove all solid material from the cooking surfaces using a brass bristle brush or plastic scourer. Brushes specifically designed for this purpose can be purchased from your BeefEater retailer. Wipe off remaining residue with a paper towel.
- Gently wash the surface of the grills with a soft sponge and a solution of hot water and a mild dishwashing liquid. Do not use highly caustic, harsh or abrasive chemical cleaners to clean the cooking grills. Always check the manufacturer's recommendations for the cleaner prior to use.
- Coat the grills with a layer of cooking oil. This will help protect the surfaces between uses.
- For porcelain enamel coated cooking surfaces, do not use any metal tools to clean the surface. Use only a brass bristle wire brush to remove hard deposits.

Do not clean the cooking surfaces in a dishwashing machine. For hard deposits and heavy grease, do not use steel wool or metal scrapers. Use concentrated detergent or domestic cleaning powders.

Cleaning The Drip Tray

Never remove the grease tray while the barbecue is hot. Always remove and clean the grease tray after the unit has cooled down.

Replace aluminium foil on main drip tray (if used) and clean both waste trays at regular intervals to prevent grease build-up, which could result in a grease fire and void the barbecue warranty.

Cleaning The Burners

- Check main opening, throat and venturi to each burner regularly for insect nests (eg. wasp, ants or spiders). Nests are dangerous and must be cleaned out thoroughly.
- Remove burners periodically and scrub clean with soapy water and a wire brush making sure that the ports are free of obstructions.

Replace burners in the correct position and dry by lighting each one to avoid subsequent corrosion.

A clogged burner can lead to a fire beneath the grill.

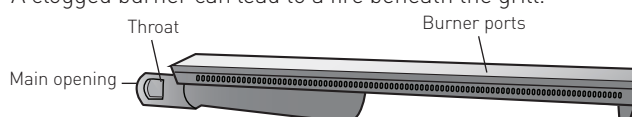

Storing Your Barbecue

When storing barbecue for extended periods, be certain all controls and cylinder valves are turned off. If storing the barbecue indoors remove gas cylinder and store the cylinder in a ventilated area outdoors.

Gas cylinders must be stored outdoors, out of reach of children and must not be stored in a building, garage or any other enclosed area.

The barbecue should be covered when not in use. eg a polyester or vinyl barbecue cover. Frequently check and tighten all nuts and bolts on the barbecue and trolley

The gas cylinder supply valve must be turned off when the appliance is not in use.



WARNING

Note: For storage and cylinder exchange, disconnect hose at the cylinder only, do not disconnect hose from appliance.

Please note that environmental conditions need to be taken into account with regards to the maintenance required on your product. In particular units installed in humid climates or seaside locations will be more susceptible to surface corrosion/discolouration over time. In these conditions Electrolux strongly recommends cleaning and drying your barbecue after every use and covering it when not in use to minimise exposure to the elements.

MAINTENANCE

This appliance should be checked and serviced by an authorised service person every 2 years to ensure the appliance remains in a safe operating condition. (These services are not covered by warranty). Replacement parts are available from your authorised BeefEater Dealer.

Service and Maintenance Schedules	Each Use	6 Monthly	2 Yearly
Check gas supply hose(s) for cracks and leaks	✓		
Check gas regulator for leaks	✓		
Check that all gas fittings are tight	✓		
Inspect and clean ignition module and probe		✓	
Inspect and clean barbecue Burners		✓	
Check gas cylinder expiration date		✓	
Inspect and clean gas injectors			✓
Check gas control valve on cylinder			✓
Inspect gas control valves			✓
Inspect and proof all internal structure barbecue and trolley			✓

TROUBLESHOOTING

Condition	Possible Cause	Solution
Flame goes out while in use	Empty gas cylinder	Replace cylinder
	Air mixed in hoses	Re-ignite and allow operating for a short while, till clears out
	Blockage	Seek professional assistance
Ignition failure	Gas cylinder valve close	Turn off knob button, then open the cylinder valve
	Air mixed in the hoses	Re-ignite and allow operating for a short while, till clears out
	Rubber hose wrapped, deformed Or pinched	Foul smell of gas
	Spark escaping	Ensure the spark probe is in Place, not deformed, clean
	No spark	Seek professional assistance
Foul smell of gas	Damage to hose	Turn cylinder valve off, replace Hose
	Leakage	Leak-test, and tighten where required. If leakage can't be rectified, cease using appliance, and seek professional assistance
	Burner went off	Shut off valves, wait for 5 minutes and reignite
	Incorrect combustion	Seek professional assistance
Flame appear to separate off the Burner or flame burns with noise	Blockage of burner ports	Clean the burner thoroughly. If problem persists, seek Professional assistance
Yellow tipping in flame	Air/gas mixture screw in burner Incorrect	Try to open screw to remove Yellow. If not changing, seek Professional assistance



FOR SALES IN AUSTRALIA AND NEW ZEALAND
 APPLIANCE: BEEFEATER DISCOVERY BARBECUE

This document sets out the terms and conditions of the product warranties for Electrolux Appliances. It is an important document. Please keep it with your proof of purchase documents in a safe place for future reference should there be a manufacturing defect in your Appliance. This warranty is in addition to other rights you may have under the Australian Consumer Law.

1. In this warranty:
 - (a) 'acceptable quality' as referred to in clause 10 of this warranty has the same meaning referred to in the ACL;
 - (b) 'ACL' means Schedule 2 to the Competition and Consumer Act 2010;
 - (c) 'Appliance' means any Electrolux product purchased by you and accompanied by this document;
 - (d) 'ASC' means Electrolux's authorised service centres;
 - (e) 'Electrolux' means Electrolux Home Products Pty Ltd of 163 O'Riordan Street, Mascot, NSW 2020, ABN 51 004 762 341 in respect of Appliances purchased in Australia and Electrolux (NZ) Limited (collectively 'Electrolux') of 3-5 Niall Burgess Road, Mount Wellington, in respect of Appliances purchased in New Zealand;
 - (f) 'major failure' as referred to in clause 10 of this warranty has the same meaning referred to in the ACL;
 - (g) "Warranty Period" means the period of 12 months following the date of original purchase of the Appliance in Australia or New Zealand and in the case of the burner box, an additional 4 years.
2. This warranty only applies to Appliances, purchased and used in Australia or New Zealand in normal domestic applications and is in addition to (and does not exclude, restrict, or modify in any way) any non-excludable statutory guarantees in Australia and New Zealand.
3. During the Warranty Period Electrolux or its ASC will, at no extra charge if your Appliance is readily accessible for service, without special equipment and subject to these terms and conditions, repair or replace any parts which it considers to be defective. Electrolux or its ASC may use remanufactured parts to repair your Appliance. You agree that any replaced Appliances or parts become the property of Electrolux. This warranty does not apply to light globes, batteries, filters or similar perishable parts.
4. Parts and Appliances not supplied by Electrolux are not covered by this warranty.
5. To the extent permitted by law, you will bear the cost of transportation, travel and delivery of the Appliance to and from Electrolux or its ASC. If you reside outside of the service area, you will bear the cost of:
 - (a) travel of an authorised representative;
 - (b) transportation and delivery of the Appliance to and from Electrolux or its ASC. In all instances, unless the Appliance is transported by Electrolux or an Electrolux authorised representative, the Appliance is transported at the owner's cost and risk while in transit to and from Electrolux or its ASC.
6. Proof of purchase is required before you can make a claim under this warranty.
7. You may not make a claim under this warranty unless the defect claimed is due to faulty or defective parts or workmanship. Electrolux is not liable in the following situations (which are not exhaustive):
 - (a) the Appliance is damaged by:
 - (i) accident
 - (ii) misuse or abuse, including failure to properly maintain or service
 - (iii) normal wear and tear
 - (iv) power surges, electrical storm damage or incorrect power supply
 - (v) incomplete or improper installation
 - (vi) incorrect, improper or inappropriate operation
 - (vii) insect or vermin infestation
 - (viii) failure to comply with any additional instructions supplied with the Appliance;
 - (b) the Appliance is modified without authority from Electrolux in writing;
 - (c) the Appliance's serial number or warranty seal has been removed or defaced;
 - (d) the Appliance was serviced or repaired by anyone other than Electrolux, an authorised repairer or ASC.
8. This warranty, the contract to which it relates and the relationship between you and Electrolux are governed by the law applicable where the Appliance was purchased. Where the Appliance was purchased in New Zealand for commercial purposes the Consumer Guarantee Act does not apply.
9. To the extent permitted by law and subject to your non-excludable statutory rights and guarantees, Electrolux excludes all warranties and liabilities (other than as contained in this document) including liability for any loss or damage whether direct or indirect arising from your purchase, use or non-use of the Appliance.
10. For Appliances and services provided by Electrolux in Australia, the Appliances come with guarantees by Electrolux that cannot be excluded under the ACL. You are entitled to a replacement or refund for a major failure and for compensation for any other reasonably foreseeable loss or damage. You are also entitled to have the Appliance repaired or replaced if the Appliance fails to be of acceptable quality and the failure does not amount to a major failure. The benefits to you given by this warranty are in addition to your other rights and remedies under a law in relation to the Appliances or services to which the warranty relates.
11. For Appliances and services provided by Electrolux in New Zealand, the Appliances come with a guarantee by Electrolux pursuant to the provisions of the Consumer Guarantees Act, the Sale of Goods Act and the Fair Trading Act.
12. To enquire about claiming under this warranty, please follow these steps:
 - (a) carefully check the operating instructions, user manual and the terms of this warranty;
 - (b) have the model and serial number of the Appliance available;
 - (c) have the proof of purchase (e.g. an invoice) available;
 - (d) telephone the numbers shown below.
13. You accept that if you make a warranty claim, Electrolux and its ASC may exchange information in relation to you to enable Electrolux to meet its obligations under this warranty.

Important Notice

Before calling for service, please ensure that the steps listed in clause 12 above have been followed.

FOR SERVICE or to find the address of your nearest state service centre in Australia PLEASE CALL 1800 356 660 <small>For the cost of a local call (Australia only)</small>	SERVICE AUSTRALIA ELECTROLUX HOME PRODUCTS beefeaterbbq.com	FOR SPARE PARTS or to find the address of your nearest state spare parts centre in Australia PLEASE CALL 1300 666 019 <small>For the cost of a local call (Australia only)</small>
FOR SERVICE or to find the address of your nearest authorised service centre in New Zealand FREE CALL 0800 10 66 10 <small>(New Zealand only)</small>	SERVICE NEW ZEALAND ELECTROLUX (NZ) Limited beefeaterbbq.com	FOR SPARE PARTS or to find the address of your nearest state spare parts centre in New Zealand FREE CALL 0800 10 66 20 <small>(New Zealand only)</small>

BDB_Warr_May16

For more information on all Beefeater products, or for dimension and installation information, call into your retailer, phone or email our customer care team or visit our website:

AUSTRALIA

phone: 1300 307 939

fax: 1800 356 669

email: customercare@electrolux.com.au

web: beefeaterbbq.com

NEW ZEALAND

phone: 0800 436 245

fax: 0800 225 088

email: customercare@electrolux.co.nz

web: beefeaterbbq.com

Beefeater. We are part of the Electrolux Family.
To add a touch of professional inspiration to
your home, visit electrolux.com.au