

# INDUCTION COOKTOPS

WHI634BB, WHI955BB

# CONGRATULATIONS

Dear customer,

Congratulations on the purchase of your new cooktop.

Before you use the cooktop, we recommend that you read through the whole user manual which provides the description of the cooktop and its functions.

To avoid the risks that are always present when you use an electrical appliance, it is important that the cooktop is installed correctly and that you read the safety instructions carefully to avoid misuse and hazards.

We recommend that you keep this instruction booklet for future reference and pass it on to any future owners.

After unpacking the appliance, please check it is not damaged. If in doubt, do not use the appliance but contact your local Customer Care Centre.

For contact details, refer to the last page of this user manual. This appliance complies with requirements of Australian Standard AS/NZS 60335.2.6

## Conditions of use

This appliance is intended to be used in household and similar applications such as:

- Staff kitchen areas in shops, offices and other working environments
- Farm houses
- By clients in hotels, motels and other residential type environments
- Bed and breakfast type environments

**Please ensure you read the instruction manual fully before you call for service, or a full service fee could be applicable.**

Record model and serial number here:

Model number:.....

Serial number:.....

PNC:.....

# CONTENTS

Important safety instructions.....	3
Installation instructions.....	5
Specifications.....	7
Product description.....	8
Operating instructions.....	11
Helpful hints and tips.....	13
Care and cleaning.....	14
Troubleshooting.....	15
Warranty.....	17
Notes.....	18

Please read the user manual carefully and store in a handy place for later reference.

The symbols you will see in this booklet have these meanings:



## WARNING

This symbol indicates information concerning your personal safety.



## CAUTION

This symbol indicates information on how to avoid damaging the appliance.



## IMPORTANT

This symbol indicates tips and information about use of the appliance.



## ENVIRONMENT

This symbol indicates tips and information about economical and ecological use of the appliance.

# IMPORTANT SAFETY INSTRUCTIONS

## IMPORTANT INFORMATION THAT MAY IMPACT YOUR MANUFACTURER'S WARRANTY

Adherence to the directions for use in this manual is extremely important for health and safety. Failure to strictly adhere to the requirements in this manual may result in personal injury, property damage and affect your ability to make a claim under the Westinghouse manufacturer's warranty provided with your product. Products must be used, installed and operated in accordance with this manual. You may not be able to claim on the Westinghouse manufacturer's warranty in the event that your product fault is due to failure to adhere to this manual.



### IMPORTANT

Check for any damage or marks

If you find the cooktop is damaged or marked, you must report it within 7 days if you wish to claim for damage/marks under the manufacturer's warranty. This does not affect your statutory rights.



### ENVIRONMENT

Information on disposal for users

- All of the packaging materials are recyclable. Please dispose of those materials through your local recycling depot or by placing them in appropriate collection containers.
- If you wish to discard this product, please contact your local authorities and ask for the correct method of disposal.



### WARNING

Risk of suffocation, injury or permanent disability.

- Do not let persons, children included, with reduced physical sensory, reduced mental functions or lack of experience and knowledge use the appliance. They must have supervision or instruction for the operation of the appliance by a person who is responsible for their safety.
- Do not let children play with the appliance.
- Keep all packaging away from children.
- Keep children and pets away from the appliance when it operates or when it cools down. Accessible parts are hot.
- If the appliance has a child safety device, we recommend that you activate it.

## Installation



### WARNING

Only a qualified person must install this appliance.

- Remove all the packaging.
- Do not install or use a damaged appliance.
- Obey the installation instruction supplied with the appliance.
- Keep the minimum distance from the other appliances and units.
- Always be careful when you move the appliance because it is heavy. Always wear safety gloves.
- Seal the cut surfaces with a sealant to prevent moisture to cause swelling.
- Protect the bottom of the appliance from steam and moisture.
- Do not install the appliance adjacent to a door or under a window. This prevents hot cookware to fall from the appliance when the door or the window is opened.
- If the appliance is installed above drawers make sure that the space, between the bottom of the appliance and the upper drawer, is sufficient for air circulation.
- Make sure that the ventilation space of 5 mm, between the worktop and the front of the below unit, is free. The warranty does not cover damages caused by the lack of an adequate ventilation space.
- The bottom of the appliance can get hot. We recommend to install a non-combustible separation panel under the appliance to prevent access to the bottom.

# IMPORTANT SAFETY INSTRUCTIONS

## Electrical connection



### WARNING

Risk of fire and electrical shock.

- All electrical connections must be made by a qualified electrician. Before wiring make sure the mains terminal is not live.
- Make sure the appliance is installed correctly. Loose and incorrect plug and socket connections can make the terminal become too hot.
- The appliance must be installed correctly to ensure anti-shock protection.
- Cables from other electrical appliances must not touch the hot surface of the appliance.
- Other than the connection point in the terminal block, do not let the electrical supply cord touch the appliance or hot cookware. Ensure electrical supply cord is not tangled.
- Use a strain relief clamp on cable.
- Use the correct mains cable.
- Make sure there is no damage to the mains plug and to the mains cable. Contact the Service Centre or an electrician to change a damaged mains cable.
- The electrical installation must have an isolation device which lets you disconnect the appliance from the mains at all poles. The isolation device must have a contact opening width of minimum 3mm.
- Use only correct isolation devices: line protecting cut-outs, fuses (screw type fuses removed from the holder), earth leakage trips and contactors.

## Use



### WARNING

Risk of injury, burns or electric shock.

- Use this appliance in a household environment.
- Do not change the specification of this appliance.
- Do not use an external timer or a separate remote-control system to operate the appliance.
- Do not let the appliance stay unattended during operation.
- Do not operate the appliance with wet hands or when it has contact with water.
- Do not put cutlery or saucepan lids on the cooking zones. They can become hot.
- Set the cooking zone to "off" after each use. Do not rely on the pan detector.
- Do not use the appliance as a work surface or as a storage surface.
- If there is a crack on the surface, disconnect power supply to prevent the electrical shock.

- Users with a pacemaker must keep a distance of minimum 30 cm from the induction cooking zones when the appliance is in operation.



### WARNING

Risk of fire or explosion.

- Fats and oil when heated can release flammable vapours. Keep flames or heated objects away from fats and oils when you cook with them.
- The vapours that very hot oil releases can cause spontaneous combustion.
- Used oil, that can contain food remnants, can cause fire at a lower temperature than oil used for the first time.
- Do not put flammable products or items that are wet with flammable products in, near or on the appliance.
- Do not try to extinguish a fire with water. Disconnect the appliance and cover the flame with a lid or a fire blanket.



### WARNING

Risk of damage to the appliance.

- Do not keep hot cookware on the control panel.
- Do not let cookware to boil dry.
- Be careful not to drop utensils or cookware on the glass, the glass surface can be damaged
- Do not activate the cooking zones with empty cookware or without cookware.
- Do not put aluminium foil on the appliance.
- Cookware made of cast iron, aluminium or with a damaged bottom can cause scratches on the glass ceramic. Always lift these objects up when you have to move them on the cooking surface.

## Care And Cleaning



### WARNING

Risk of damage to the appliance.

- Clean regularly the appliance to prevent the deterioration of the surface material.
- Do not use water spray and steam to clean the appliance.
- Clean the appliance with a moist soft cloth. Only use neutral detergents. Do not use abrasive products, abrasive cleaning pads, solvents or metal objects.

# INSTALLATION INSTRUCTIONS

## Built-in appliances

- Only use the built-in appliances after you assemble the appliance into correct built-in units and work surfaces that align to the standards.

## Connection cable

- Use the correct mains cable of type H05BB-F Tmax 90°C (or higher) for a single phase or two phase connection.
- Replace the damaged mains cable with a special cable (type H05BB-F Tmax 90°C or higher). Speak to your local Service Centre.

## To attach the seal

- Clean the worktop in the area of the cut out section.
- Bond the seal stripe supplied on the lower edge of the appliance along the outer edge of the glass ceramic. Do not extend it. Let stay the cut ends in the middle of one side. When, you cut it to length (add some mm), push the two ends together.

## Assembly

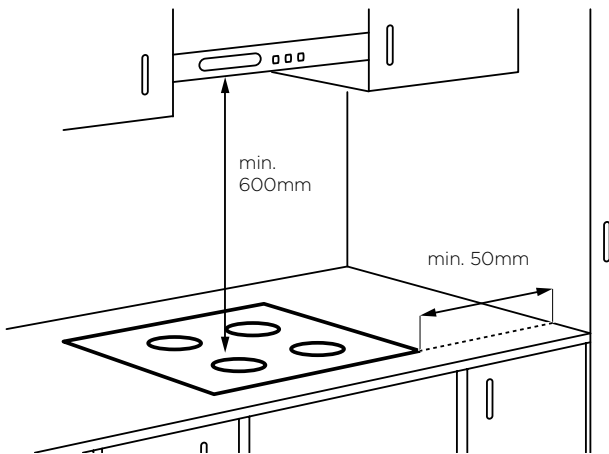

## WARNING

Refer to "Safety information" chapter.



## IMPORTANT

Before the installation, note down the serial number (Ser. Nr.) from the rating plate at the front of this manual. The rating plate of the appliance is on its lower casing.

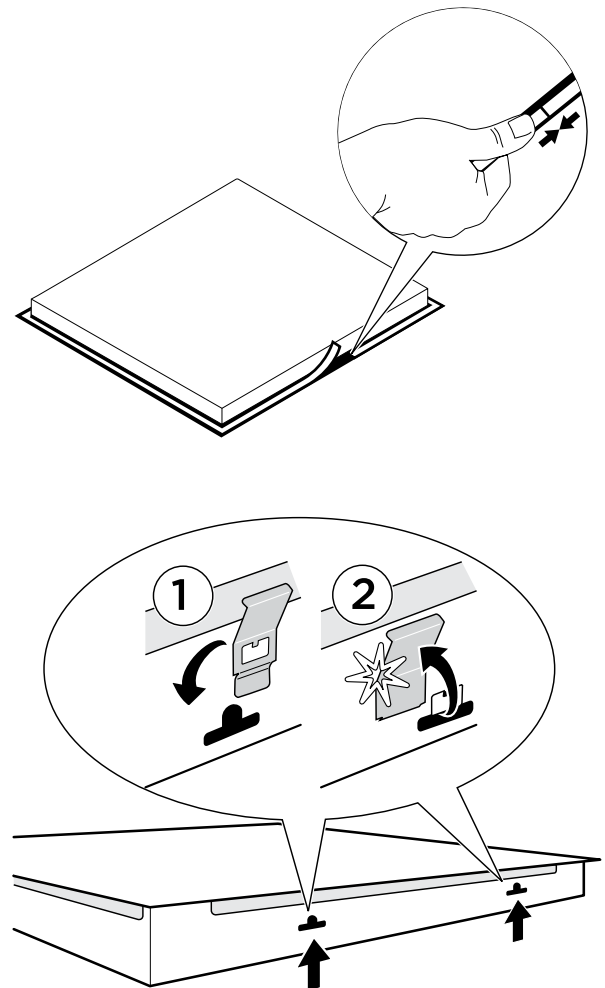

# INSTALLATION INSTRUCTIONS (CONTINUED)

## WHI634BB

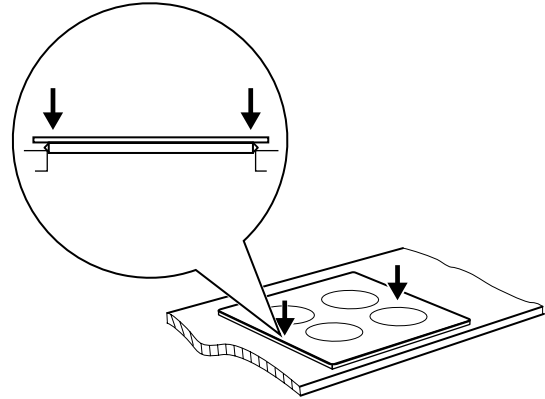
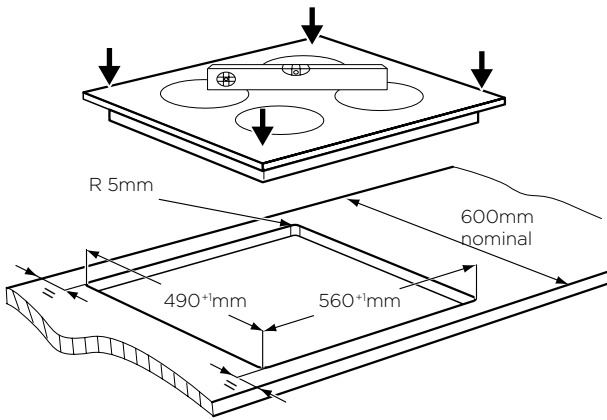

## WHI955BB

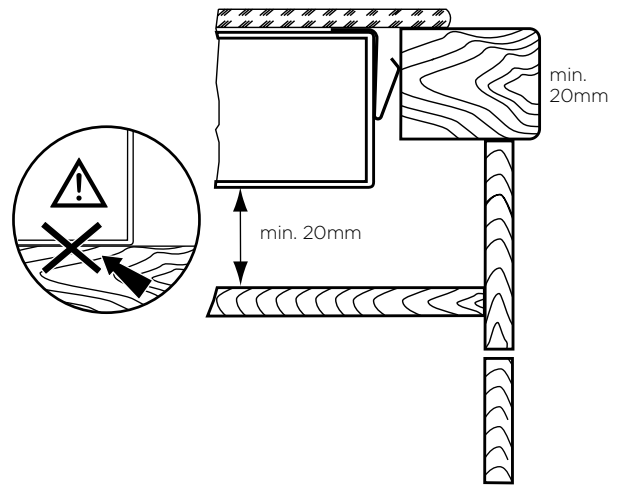
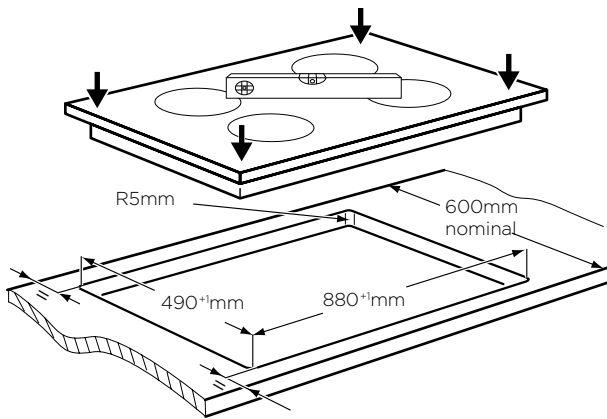

It is recommended to centre the bench cutout with equal distance front and back as shown but the product has also been certified to be installed with no clearance between the rear edge of the cooktop glass and rear wall if required. In doing so installers still need to leave sufficient clearance to take into account that the glass dimensions are larger than the cut out

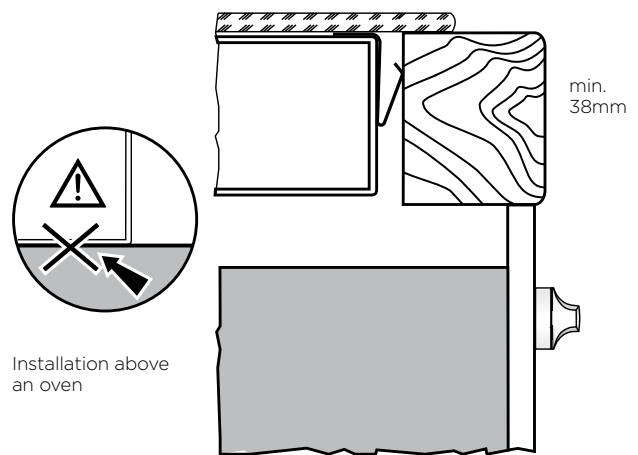

# SPECIFICATIONS

## Technical data

	WHI634BB	WHI955BB
PNC	949 163 388	949 163 389
Product dimensions (wxd) mm	590 x 520	910 x 520
Cut-out dimensions (wxd)mm	560 x 490	880 x 490
Voltage (volts)	220-240	220-240
Cycles (Hz)	50-60	50-60
Total power (Watts)	6500	10600
Elements- Without/ With Boost (Watts)	3	5
Front Left	1400/2500	2300/3200
Rear Left	1800/2800	2300/3200
Front Right	3600/5200	1800/2800
Rear Right	N/A	1400/2500
Centre	N/A	2300/3200

# PRODUCT DESCRIPTION

## WHI634BB

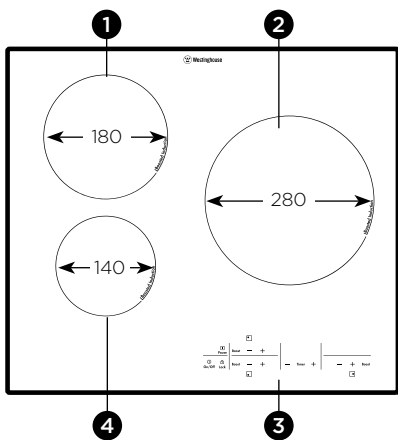

- ❶ Induction cooking zone 1800 W, with Power function 2800 W (minimum cookware diameter =140 mm).
- ❷ Induction cooking zone 3500 W, with Power function 5200 W (minimum cookware diameter =145 mm).
- ❸ Control panel
- ❹ Induction cooking zone 1400 W, with Power function 2500 W (minimum cookware diameter =125 mm).

## WHI954BA

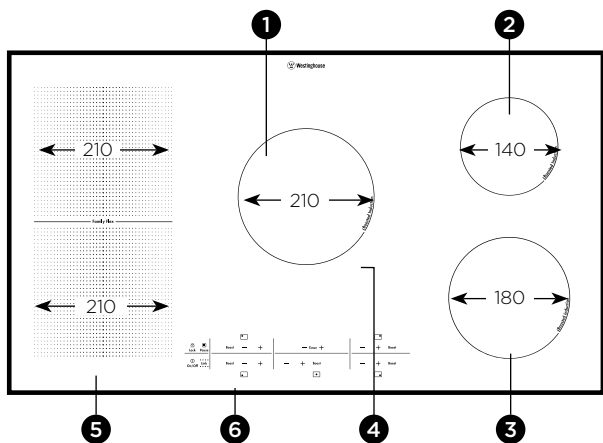

- ❶ Induction cooking zone 2300 W, with Power function 3200 W (minimum cookware diameter =125 mm).
- ❷ Induction cooking zone 1400 W, with Power function 2500 W (minimum cookware diameter =125 mm).
- ❸ Induction cooking zone 1800 W, with Power function 2800 W (minimum cookware diameter =140 mm).
- ❹ Induction cooking zone 2300 W, with Power function 3200 W (minimum cookware diameter =125 mm).
- ❺ Induction cooking zone 2300 W, with Power function 3200 W (minimum cookware diameter =125 mm).
- ❻ Control panel

# PRODUCT DESCRIPTION (CONTINUED)

Control panel layout - WHI634BB

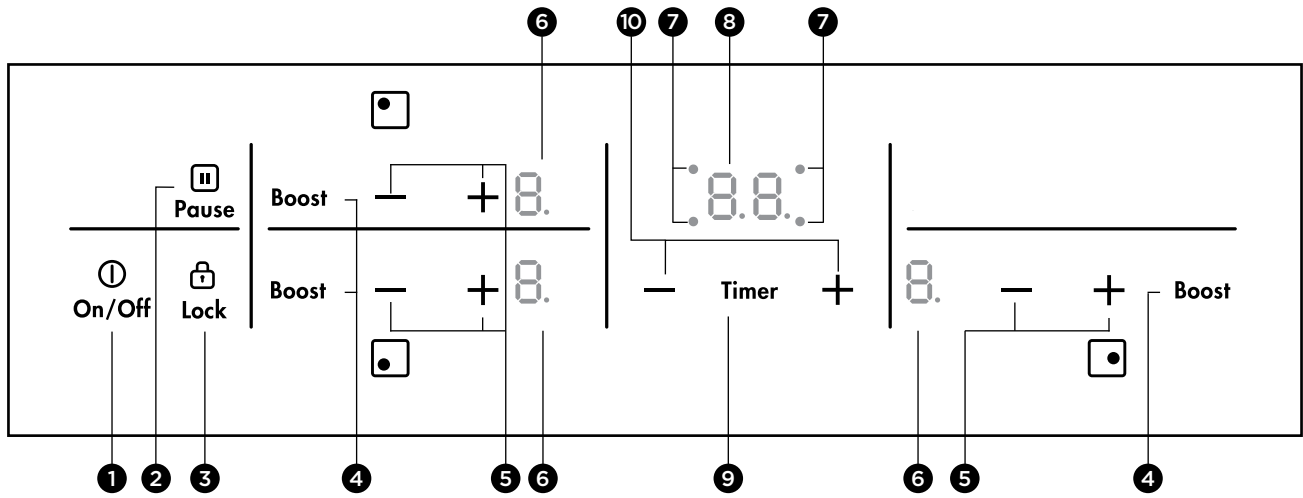

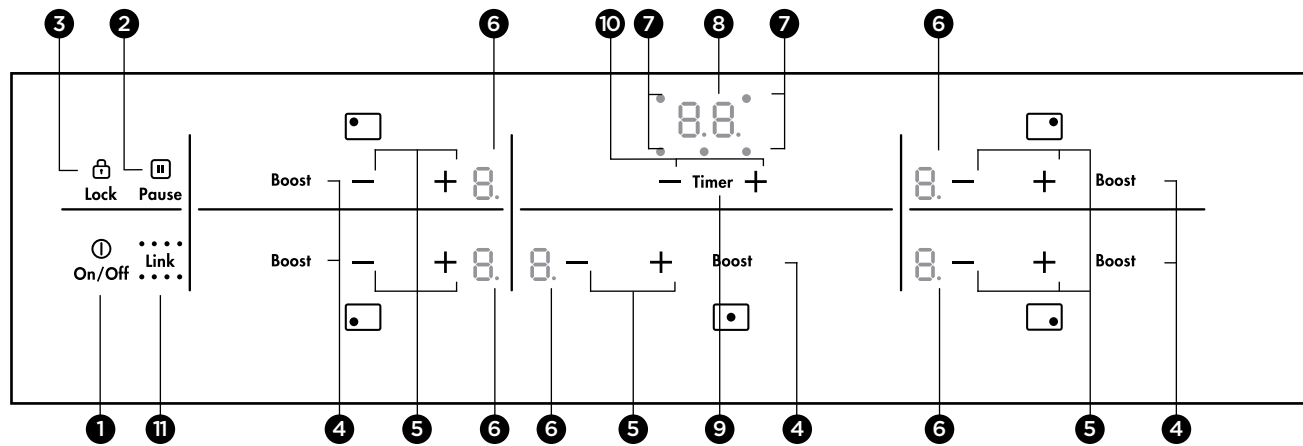

Control panel layout - WHI955BB













## PRODUCT DESCRIPTION (CONTINUED)

Use the sensor fields to operate the appliance. The displays, indicators and sounds tell which functions operate.

	SENSOR FIELD	FUNCTION
1	On/Off	It activates and deactivates the appliance
2	 Pause	Sets all operating zones to a keep warm setting
3	Lock	It locks/unlocks the control panel
4	Boost	It activates the Power function
5	—/+	It increases or decreases the heat setting
6	A heat setting display	It shows the heat setting
7	Cooking zones' indicators of timer	It shows for which zone you set the time
8	The timer display	It shows the time in minutes
9	Timer	It selects the cooking zone
10	—/+	It increases or decreases the time
11	 Link	Connects left hand zones (selected models)

### Heat setting displays

DISPLAY	DESCRIPTION
	The cooking zone is deactivated.
	The Keep Warm function operates.
	The cooking zone operates.
	The Automatic Heat-up function operates.
	The cookware is incorrect or too small, or there is no cookware on the cooking zone.
	There is a malfunction.
	A cooking zone is still hot (residual heat).
	The Lock/Child Safety device operates.
	The Power function operates.
	The Automatic Switch-Off operates.

### Residual heat indicator

The induction cooking zones make the heat necessary for cooking directly in the bottom of the cookware. The glass ceramic is hot from the heat of the cookware.



#### WARNING

 Risk of burns from residual heat!

# OPERATING INSTRUCTIONS

## Activation and deactivation

Touch **On/Off** for 1 second to activate or deactivate the appliance.

## Automatic switch off

The function deactivates the appliance automatically if:

- All cooking zones are deactivated (0).
- You do not set the heat setting after you activate the appliance.
- You spill something or put something on the control panel for more than 10 seconds, (a pan, a cloth, etc). The sound operates some time and the appliance deactivates. Remove the object or clean the control panel.
- The appliance become too hot (e.g. when a saucepan boils dry). Before you use the appliance again, the cooking zone must be cool.
- You use incorrect cookware. The symbol (F) comes on and the cooking zone deactivates automatically after 2 minutes.
- You do not deactivate a cooking zone or change the heat setting. After some time, (□) comes on and the appliance deactivates. See the Heat Setting display table below.

## The times of Automatic Switch Off

HEAT SETTING	COOKING ZONE DEACTIVATES AFTER
0 - 2	6 hours
3 - 4	5 hours
5	4 hours
6 - 9	1.5 hours

## The heat setting

Touch **+** adjacent to the element you want to control to increase the heat setting. Touch **-** adjacent to the element you want to control to decrease the heat setting. The display shows the heat setting. Touch **+** and **-** adjacent to the element you want to control at the same time to deactivate the cooking zone (does not apply to WHI954BA).

## Automatic heat up

You can get a necessary heat setting in a shorter time if you activate the Automatic Heat Up function. This function sets the highest heat setting for some time (see the illustration), and then decreases to the necessary heat setting.

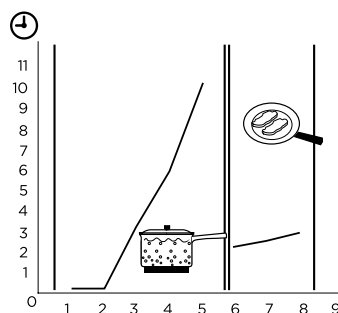

## To start the Automatic Heat Up function for a cooking zone:

1. Touch **Boost**. The symbol (P) comes on in the display.
2. Immediately touch **+** adjacent to the element you want to control. The symbol (H) comes on in the display.
3. Immediately touch **-** adjacent to the element you want to control again and again until the necessary heat setting comes on. After 3 seconds (R) comes on in the display.
4. To stop the function touch **+** adjacent to the element you want to control.

## Power function

The Power function makes more power available to the induction cooking zones. The Power function is activated for 10 minutes at most. After, that the induction cooking zone automatically sets back to highest heat setting. To activate, touch **Boost**, (P) comes on. To deactivate, touch **Boost** or **-** adjacent to the element you want to control.

## Power management

The power management divides the power between two cooking zones in a pair (see the illustration). The power function increases the power to the maximum level for one cooking zone in the pair. It automatically decreases the power in the second cooking zone to a lower level. The display for the reduced zone change between two levels.

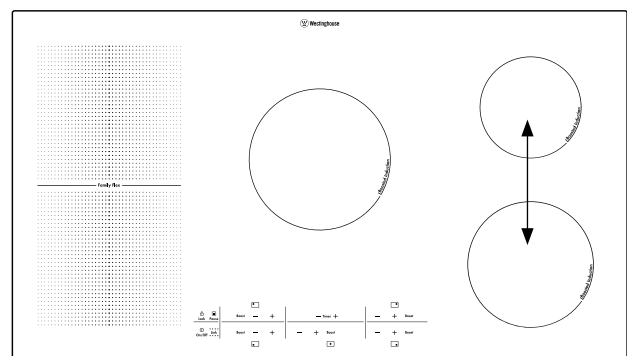
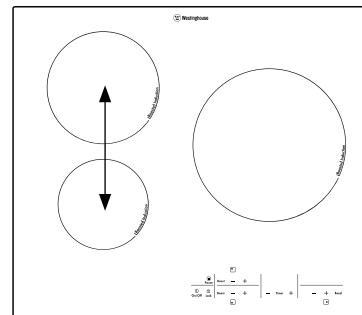

## Timer

Use the Count Down Timer to set how long the cooking zone operates for only this one time. Set the Timer after the selection of the cooking zone.

You can set the heat setting before or after you set the timer.



- To set the cooking zone: touch **Timer** again and again until the indicator of a necessary cooking zone comes on.
- To activate or change the Timer: touch **—** or **+** of the timer to set the time (00 - 99 minutes). When the indicator of the cooking zone starts to flash slow, the time counts down.
- To deactivate the Timer: set the cooking zone with **Timer** and touch **—** to deactivate the Timer. The remaining time counts back to 00. The indicator of the cooking zone goes out.
- To see the remaining time: set the cooking zone with **Timer**. The indicator of the cooking zone starts to flash quickly. The display shows the remaining time. When the time comes to an end, the sound operates and 00 flashes. The cooking zone deactivates.
- To stop the sound: touch **Timer**. You can use the Timer as a minute minder while the cooking zones do not operate. Touch **Timer**. Touch **+** or **—** to set the time. When the time comes to an end, the sound operates and 00 flashes.
- To stop the sound: touch **Timer**.

## Pause

The **Pause** function sets all cooking zones that operate to the lowest heat setting .

When **Pause** operates, you cannot change the heat setting.

The **Pause** function does not stop the timer function.

- To activate this function touch . The  symbol comes on.
- To deactivate this function touch . The heat setting that you set before comes on.

## Link Function (model WHI955BB)

The Link Function can be used with the griddle plate accessory (sold separately).

The **Link** function connects two cooking zones and they operate as one.

First set the heat setting for one of the **Left** hand cooking zones. To start the Link function touch .

To set or change the heat setting touch one of the left hand controls.

To stop the Link function touch . The cooking zones will then operate independently.

## Lock

When the cooking zones operate, you can lock the control panel, but not **On/Off**. It prevents an accidental change of the heat setting.

First set the heat setting. To start this function touch **Lock**. The symbol  comes on for 4 seconds. The Timer stays on.

To stop this function touch **Lock**. The heat setting that you set before comes on. When you stop the appliance, you also stop this function.

## The child safety device

This function prevents an accidental operation of the appliance.

### To activate the child safety device

- Activate the appliance with **On/Off**. Do not set the heat settings.
- Touch **Lock** for 4 seconds. The symbol  comes on.
- Deactivate the appliance with **On/Off**.

### To deactivate the child safety device

- Activate the appliance with **On/Off**. Do not set the heat settings. Touch **Lock** for 4 seconds. The symbol  comes on.
- Deactivate the appliance with **On/Off**.

### To override the child safety device for only one cooking time

- Activate the appliance with **On/Off**. The symbol comes on .
- Touch **Lock** for 4 seconds. Set the heat setting in 10 seconds. You can operate the appliance.
- When you deactivate the appliance with **On/Off**, the child safety device operates again.

## Count down timer

Use the Count Down Timer to set how long the cooking zone operates for one cooking session. Set the Count Down Timer after the selection of the cooking zone. You can set the heat setting before or after you set the timer.

- To set the cooking zone: touch **Timer** again and again until the indicator of the required cooking zone comes on.
- Starting the Count Down Timer: touch **+** of the timer to set the time (00 - 99 minutes). When the indicator of the cooking zone flashes slower, the time counts down.
- Checking the remaining time: select the cooking zone with **Timer**. The indicator of the cooking zone flashes faster. Display shows the remaining time.
- Changing the Count Down Timer: select the cooking zone with **Timer** touch **+** or **—**.
- Stopping the timer: select the cooking zone with **Timer**. Touch **—**. The remaining time counts backwards to 00. The indicator of the cooking zone goes out. To switch off you can also touch **+** and **—** at the same time.
- When the time elapses, the sound operates and 00 flashes. The cooking zone switches off.
- Stopping the sound: touch **Timer**.

## HELPFUL HINTS AND TIPS



### IMPORTANT

Use the induction cooking zones with correct cookware.

#### Cookware for induction cooking zones



### IMPORTANT

For induction cooking zones a strong electromagnetic field creates the heat in the cookware very quickly.

#### Cookware material

- **Correct:** cast iron, steel, enamelled steel, stainless steel, the bottom made of multi-layer (with correct mark from a manufacturer).
- **Not correct:** aluminium, copper, brass, glass, ceramic or porcelain.

#### Cookware is correct for an induction hob if ...

- Some water boils very quickly on a zone set to the highest heat setting.
- A magnet pulls on to the bottom of the cookware.



### IMPORTANT

The bottom of the cookware must be as thick and flat as possible. Cookware dimensions: induction cooking zones adapt to the dimension of the bottom of the cookware automatically to some limit.

#### Examples of cooking applications

The data in the table is for guidance only.

HEAT SETTING	USE TO:	TIME	HINTS
1	Keep warm the food you cooked	as required	Put a lid on a cookware
1-2	Hollandaise sauce, melt: butter, chocolate, gelatine	5-25 min	Mix from time to time
1-2	Solidify: fluffy omelettes, baked eggs	10-40 min	Cook with a lid on
2-3	Simmer rice and milk based dishes, heating up ready-cooked meals	25-50 min	Add the minimum twice as much liquid as rice, mix milk dishes part procedure through
3-4	Steam vegetables, fish, meat	20-45 min	Add some tablespoons of liquid
4-5	Steam potatoes	20-60 min	Use max. 1/4 L water for 750g of potatoes
4-5	Cook larger quantities of food, stews and soups	60-150 min	Up to 3 L liquid plus ingredients
6-7	Gentle fry: escalope, veal cordon bleu, cutlets, rissoles, sausages, liver, roux, eggs, pancakes, doughnuts	as required	Turn halfway through
7-8	Heavy fry, hash browns, loin steaks, steaks	5-15 min	Turn halfway through
9	Boil large quantities of water, cook pasta, sear meat (goulash, pot roast), deep-fry chips		

The Power function is best to heat up large quantities of water.

#### The noises during operation

If you can hear

- **crack noise:** cookware is made of different materials (Sandwich construction).
- **whistle sound:** you use one or more cooking zones with high power levels and the cookware is made of different materials (Sandwich construction).
- **humming:** you use high power levels.
- **clicking:** electric switching occurs.
- **hissing, buzzing:** the fan operates.

#### The noises are normal and do not refer to appliance malfunction.

If unfamiliar with induction units, please first compare the operating sounds of a demonstration model at your retailer before calling service. If a service call is placed and the sounds are normal, you will be charged for the visit.

#### Energy saving



### ENVIRONMENT

- If it is possible, always put the lids on the cookware.
- Put cookware on a cooking zone before you start it.

# CARE AND CLEANING

## Care and cleaning

Clean the appliance after each use. Always use cookware with clean bottom.



### IMPORTANT

Scratches or dark stains on the glass ceramic have no effect on how the appliance operates.

#### To remove the dirt:



1. **Remove immediately:** melted plastic, plastic foil, and food with sugar. If not, the dirt can cause damage to the appliance. Use a special scraper for the glass. Put the scraper on the glass surface at an acute angle and move the blade on the surface.





**Remove after the appliance is sufficiently cool:**

limescale rings, water rings, fat stains, shiny metallic discolorations. Use a special cleaning agent for glass ceramic or stainless steel.

2. Clean the appliance with a moist cloth and some detergent.
3. At the end **rub the appliance dry with a clean cloth.**

# TROUBLESHOOTING

PROBLEM	POSSIBLE CAUSE AND REMEDY	REMEDY
Red rings, limescale or water rings, shiny metallic or other discolouration, scratches/ shadows, bubbles or other miscellaneous marks or stains on ceramic glass cooktop surface.	Cooktop surface has not been cleaned correctly. Cleaning/ maintenance of the cooktop surface is not covered under warranty. If a service call is placed to clean the cooktop you will be charged for the visit.	Use a ceramic glass cleaner such as Cerapol.
Pitting of ceramic glass surface.	Spillovers of liquid with high sugar content.	These types of spills must be removed immediately with a special scraper for the glass. If not, permanent damage to the cooktop glass can occur, which is not covered under warranty.
You cannot activate the appliance or operate it.	<ul style="list-style-type: none"> <li>You touched 2 or more sensor fields at the same time.</li> <li> The <b>Pause</b> function operates.</li> <li>There is water or fat stains on the control panel.</li> </ul>	<ul style="list-style-type: none"> <li>Touch only one sensor field.</li> <li>Refer to the chapter "Operating instructions"</li> <li>Clean the control panel.</li> </ul>
You cannot activate the appliance or operate it.	Activate the appliance again and set the heat setting in 10 seconds. <ul style="list-style-type: none"> <li>You touched 2 or more sensor fields at the same time.</li> <li>The Child Safety Device or the <b>Lock</b> or <b>Pause</b>  operates.</li> <li>There is water or fat stains on the control panel.</li> </ul>	<ul style="list-style-type: none"> <li>Only touch one sensor field.</li> <li>See the chapter "Operating instructions".</li> <li>Clean the control panel.</li> </ul>
A Sound operates and the appliance deactivates. A sound operates when the appliance is deactivated.	You put something on one or more sensor fields.	Remove the object from the sensor fields.
The appliance deactivates.	You put something on the  .	Remove object from the sensor field.

PROBLEM	POSSIBLE CAUSE AND REMEDY	REMEDY
The residual heat indicator does not come on.	The cooking zone is not hot because it operated only for a short time.	If the cooking zone should be hot, speak to the service centre.
The Automatic Heat Up function does not operate.	<ul style="list-style-type: none"> <li>• There is still residual heat on the cooking zone.</li> <li>• The highest heat setting is set.</li> </ul>	<ul style="list-style-type: none"> <li>• Let the cooking zone become sufficiently cool.</li> <li>• The highest heat setting has the same power as the Automatic Heat Up function.</li> </ul>
The heat setting changes between two levels.	The Power management is activated.	See the section Power management.
The sensor fields become hot.	The cookware is too large or you put it too near to the controls.	Put large cookware on the rear cooking zones if it is necessary.
 comes on	The Automatic Switch Off operates.	Deactivate the appliance and activate it again.
 comes on	<ul style="list-style-type: none"> <li>• No cookware on the cooking zone.</li> <li>• Not correct cookware.</li> <li>• The diameter of the bottom of the cookware is too small for the cooking zone.</li> </ul>	<ul style="list-style-type: none"> <li>• Put cookware on the cooking zone.</li> <li>• Use the correct cookware.</li> <li>• Move cookware to a smaller cooking zone.</li> </ul>
 and a number comes on.	There is an error in the appliance.	Disconnect the appliance from the electrical supply for some time. Disconnect the fuse from the electrical system of the house. Connect again. If  comes on again, speak to the service centre.
 comes on	There is an error in the appliance, because either the cookware boils dry or you've used incorrect cookware. Overheating protection for cooking zone operates. The automatic switch-off operates.	Deactivate the appliance. Remove the hot cookware. After approximately 30 seconds, activate the cooking zone again. If the cookware was the problem, the error message goes out of the display, but the residual heat indicator can stay. Let the cookware become sufficiently cool and refer to "Cookware for the induction cooking zone" to see if your cookware is compatible with the appliance.

**This document sets out the terms and conditions of the product warranties for Westinghouse Appliances. It is an important document. Please keep it with your proof of purchase documents in a safe place for future reference should there be a manufacturing defect in your Appliance. This warranty is in addition to other rights you may have under the Australian Consumer Law.**

**1. In this warranty:**

- (a) 'ACL' or 'Australian Consumer Law' means Schedule 2 to the Competition and Consumer Act 2010;
- (b) 'Appliance' means any Electrolux product purchased by you and accompanied by this document;
- (c) 'ASC' means Electrolux's authorised serviced centres;
- (d) 'Westinghouse' is the brand controlled by Electrolux Home Products Pty Ltd of 163 O'Riordan Street, Mascot NSW 2020, ABN 51 004 762 341 in respect of Appliances purchased in Australia and Electrolux (NZ) Limited (collectively "Electrolux") of 3-5 Niall Burgess Road, Mount Wellington, in respect of Appliances purchased in New Zealand;
- (e) 'Warranty Period' means the period specified in clause 3 of this warranty;
- (f) 'you' means the purchaser of the Appliance not having purchased the Appliance for re-sale, and 'your' has a corresponding meaning.

**2. Application:** This warranty only applies to new Appliances, purchased and used in Australia or New Zealand and is in addition to (and does not exclude, restrict, or modify in any way) other rights and remedies under a law to which the Appliances or services relate, including any non-excludable statutory guarantees in Australia and New Zealand.

**3. Warranty Period:** Subject to these terms and conditions, this warranty continues in Australia for a period of 24 months and in New Zealand for a period of 24 months, following the date of original purchase of the Appliance.

**4. Repair or replace warranty:** During the Warranty Period, Electrolux or its ASC will, at no extra charge if your Appliance is readily accessible for service, without special equipment and subject to these terms and conditions, repair or replace any parts which it considers to be defective. Electrolux may, in its absolute discretion, choose whether the remedy offered for a valid warranty claim is repair or replacement. Electrolux or its ASC may use refurbished parts to repair your Appliance. You agree that any replaced Appliances or parts become the property of Electrolux.

**5. Travel and transportation costs:** Subject to clause 7, Electrolux will bear the reasonable cost of transportation, travel and delivery of the Appliance to and from Electrolux or its ASC. Travel and transportation will be arranged by Electrolux as part of any valid warranty claim.

**6. Proof of purchase** is required before you can make a claim under this warranty.

**7. Exclusions:** You may not make a claim under this warranty unless the defect claimed is due to faulty or defective parts or workmanship. This warranty does not cover:

- (a) light globes, batteries, filters or similar perishable parts;
- (b) parts and Appliances not supplied by Electrolux;
- (c) cosmetic damage which does not affect the operation of the Appliance;

- (d) damage to the Appliance caused by:
  - (i) negligence or accident;
  - (ii) misuse or abuse, including failure to properly maintain or service;
  - (iii) improper, negligent or faulty servicing or repair works done by anyone other than an Electrolux authorised repairer or ASC;
  - (iv) normal wear and tear;
  - (v) power surges, electrical storm damage or incorrect power supply;
  - (vi) incomplete or improper installation;
  - (vii) incorrect, improper or inappropriate operation;
  - (viii) insect or vermin infestation;
  - (ix) failure to comply with any additional instructions supplied with the Appliance;

In addition, Electrolux is not liable under this warranty if:

- (a) the Appliance has been, or Electrolux reasonably believes that the Appliance has been, used for purposes other than those for which the Appliance was intended, including where the Appliance has been used for any non-domestic purpose;
- (b) the Appliance is modified without authority from Electrolux in writing;
- (c) the Appliance's serial number or warranty seal has been removed or defaced

**8. How to claim under this warranty:** To enquire about claiming under this warranty, please follow these steps:

- (a) carefully check the operating instructions, user manual and the terms of this warranty;
- (b) have the model and serial number of the Appliance available;
- (c) have the proof of purchase (e.g. an invoice) available;
- (d) telephone the numbers shown below.

**9. Australia:** For Appliances and services provided by Electrolux in Australia: Electrolux goods come with guarantees that cannot be excluded under the Australian Consumer Law. You are entitled to a replacement or refund for a major failure and for compensation for any other reasonably foreseeable loss or damage. You are also entitled to have the Appliance repaired or replaced if the Appliance fails to be of acceptable quality and the failure does not amount to a major failure. 'Acceptable quality' and 'major failure' have the same meaning as referred to in the ACL.

**10. New Zealand:** For Appliances and services provided by Electrolux in New Zealand, the Appliances come with a guarantee by Electrolux pursuant to the provisions of the Consumer Guarantees Act, the Sale of Goods Act and the Fair Trading Act. Where the Appliance was purchased in New Zealand for commercial purposes the Consumer Guarantee Act does not apply.

**11. Confidentiality:** You accept that if you make a warranty claim, Electrolux and its agents including ASC may exchange information in relation to you to enable Electrolux to meet its obligations under this warranty.

**Important Notice**

Before calling for service, please ensure that the steps listed in clause 8 above have been followed.

<p><b>FOR SERVICE</b>            or to find the address of your nearest authorised service centre in Australia  <b>PLEASE CALL 13 13 49</b>  <small>For the cost of a local call (Australia only)</small></p>	<p><b>AUSTRALIA</b>            ELECTROLUX HOME PRODUCTS            163 O'Riordan Street, Mascot NSW 2020            electrolux.com.au</p>	<p><b>FOR SPARE PARTS</b>            or to find the address of your nearest spare parts centre in Australia  <b>PLEASE CALL 13 13 50</b>  <small>For the cost of a local call (Australia only)</small></p>
<p><b>FOR SERVICE</b>            or to find the address of your nearest authorised service centre in New Zealand  <b>PLEASE CALL 0800 10 66 10</b>  <small>(New Zealand only)</small></p>	<p><b>NEW ZEALAND</b>            ELECTROLUX (NZ) Limited            3-5 Niall Burgess Road, Mount Wellington            electrolux.co.nz</p>	<p><b>FOR SPARE PARTS</b>            or to find the address of your nearest spare parts centre in New Zealand  <b>PLEASE CALL 0800 10 66 20</b>  <small>(New Zealand only)</small></p>





**For more information on all Westinghouse appliances, or for dimension and installation information, call into your retailer, phone or email our customer care team or visit our website:**

#### **AUSTRALIA**

phone: 1300 363 640

fax: 1800 350 067

email: [customercare@electrolux.com.au](mailto:customercare@electrolux.com.au)

web: [westinghouse.com.au](http://westinghouse.com.au)

#### **NEW ZEALAND**

phone: 0800 436 245

fax: 0800 225 088

email: [customercare@electrolux.co.nz](mailto:customercare@electrolux.co.nz)

web: [westinghouse.co.nz](http://westinghouse.co.nz)

#### **TOP SERVICE**

Top Service encompasses the after sales service provided by The Electrolux Group to consumers including delivery, home service and spare parts.

 and WESTINGHOUSE are trademarks of Westinghouse Electric Corporation. Used under license. All Rights Reserved.

Part Number: A14095403 Rev.A  
© 2018 Electrolux Home Products Pty Ltd  
ABN 51 004 762 341  
WMAN\_Induction\_Sep18

