

Actual product appearance may differ based on your unique configuration.



This instruction sheet provides important information regarding installation of GraceSense™ Panel-Mount Nodes, CloudGates™ ControlGates™. Please read these instructions in their entirety, and follow all safety instructions before attempting installation.

ATTENTION!

The Panel-Mount Node™ should be installed by technically qualified personnel. Failure to install the

node in accordance with applicable codes and regulations and according to the manufacturer's specified guidelines may result in electrical shock, fire hazard, poor performance or equipment failure, and may also void the product warranty.

WARNING

Warning: Only qualified persons who are familiar with the equipment being serviced and those who have received

proper safety training related to the hazards of the equipment should attempt to install these sensors. The individual must also possess proper tools, training, and be capable of repair or modification of the related equipment and its accessories. Installation should conform to appropriate codes and standards. Failure to follow these instructions may result in serious personal injury, death and/or property damage. Always follow your facility's PPE requirements when performing the installation and maintenance tasks on your equipment.

WARNING

Electrical Hazard Warning: The Panel-Mount Node/CloudGate installation require wired connections inside

your equipment panel. Do not attempt to install these nodes while the equipment is energized. Disconnect, lockout and tagout the input power source to your panel/equipment before installing or servicing these nodes.

OVERVIEW

The GraceSense™ Node/CloudGate is an environmentally rated assembly mounted on the door of an enclosure. This assembly can be used in conjunction with our GraceSense™ Vibration & Temperature Node and Hot Spot Monitor or stand-alone. The Panel-Mount Node™, CloudGate™, and ControlGates™ may consist of several transducer and sensor inputs, radios, power, and integration options based on the preselected configuration. GraceSense™ Panel-Mount™ Nodes are configurable to meet the needs of your application. You may have a Node that takes in hardwired sensor inputs, a CloudGate™ (Node with cloud connection), a ControlGate™ (Node with control integration), or a combination of these capabilities. The specific type you have can be determined by the part number, communication interfaces/ radios, or application interfaces. Reach out to Grace at sales@grace-eng.com for more information on the capabilities of our specific model.

BATTERY ASSEMBLY INSTRUCTIONS

(Applicable only if ordered with a battery)

1. Locate the battery supplied with the node.
2. Position the new battery on the node by aligning the 6-pin connector and mounting screws of the battery to match the corresponding locations on the node.
3. Insert all three battery mounting screws by turning clockwise until threads start to engage.
4. Use a 6-lobe T15 driver to tighten battery screws up to, but not exceeding the torque value of 2.5 in. lbs.
5. To replace battery, refer to the battery replacement instructions shipped with the new battery

Note: Do not attempt to disassemble GraceSense™ Node other than the external mounted battery. There are no user-serviceable components inside the node and battery assembly. Tampering with the product may void the warranty.

INSTALLATION

All installations are intended to be mounted in or on an enclosure. Installation should be performed by a qualified technician and adhere to applicable regulatory codes. These devices are intended to be mounted on the flat surface of enclosures having the same type environmental ratings. **Note:** Each Zigbee radio has a range of 30m radius line-of-sight.

Antenna Positioning

As a general rule, the antenna(s) should be positioned vertically (as shown in the images above). During installation, positioning the Node upright with the antennas oriented vertically will provide the best reception.

Power Source

The GraceSense™ Node requires power via 5V, USB Mini B, 24V DC, or 120V AC with power adapter (sold separately). When used with a battery pack, the node can be self-powered or the battery pack is used as a backup when the primary power is not available. (Continued on back)

Once installed, interface connections will be made from within the panel enclosure.

Note: De-energize the equipment, and follow your facility's Lockout/Tagout procedures before attempting to make connections to the node inside your panel/enclosure.

All installations:

- 1) Cut panel opening and mount housing assembly to enclosure with supplied gasket. (Refer to the below dimensions for panel cut-out details).
- 2) Connect low voltage interface wiring according to documentation provided with the unit.

On units configured for optional AC power:

- 1) Connect outlet device as per code.

Note: It is the responsibility of the installer to ensure adequate separation of high and low voltage circuits in the end-use product.

MECHANICAL SPECIFICATIONS

Housing: Cast aluminum base
Latch: Type 304 Stainless Steel
Cover: Polycarbonate, UV rated, V-O Flame rated
Insert Material: Acrylic UL94HB

QUESTIONS

For questions or technical support, please contact us at 1-800-280-9517.

PANEL CUTOUT

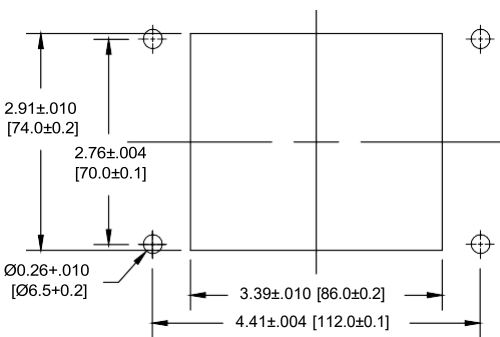

OVERALL DIMENSIONS

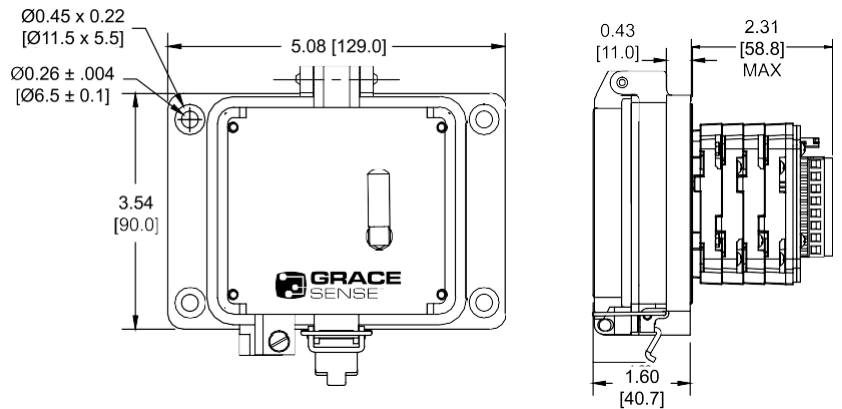

LED INDICATION CHART

Upon installation, please refer to GraceSense™ LED Indication Guide for determining what the LED indications mean.

Once the installation is complete, log into hub.gracesense.com to complete the set up.

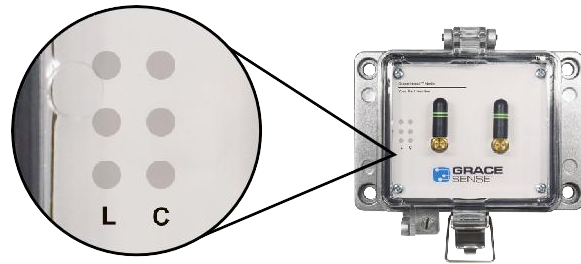

CERTIFICATIONS

Certifications only Apply to ComboGate SKUs:

- G-EIP-W1C1-K3XX
- G-EIP-W1C2-K3XX
- G-EIP-W1C3-K3XX
- G-EIP-W1C4-K3XX
- G-MIP-W1C1-K3XX
- G-MIP-W1C2-K3XX
- G-MIP-W1C3-K3XX
- G-MIP-W1C4-K3XX
- G-EIP-W1W2-K3XX
- G-MIP-W1W2-K3XX

FCC ID: 2BE57GWV1

IC: 32885-GWV1

PMN: ComboGate

HVIN: Z-100-IOT-ZBR

FVIN: GraceSense GatewayOS

This device complies with Part 15 of the FCC Rules and with License-exempt RSS standards of Industry Canada.

Operation is subject to the following two conditions: (1) This device may not cause harmful interference, and (2) This device must accept any interference received, including interference that may cause undesired operation.

Exposure to radio frequency energy. The radiated output power of this device meets the limits of FCC/ISED Canada radio frequency exposure limits. This device should be operated with a minimum separation distance of 20 cm (8 inches) between the equipment and a person's body.

WARNING: Changes or modifications not expressly approved by the party responsible for compliance could void the user's authority to operate the equipment. The term "IC:" before the radio certification number only signifies that Industry Canada technical specifications were met.

This radio transmitter [IC: 32885-GWV1] has been approved by Innovation, Science and Economic Development Canada to operate with the antenna type(s) listed below, with the maximum permissible gain indicated. Antenna types not included in this list that have a gain greater than the maximum gain indicated for any type listed are strictly prohibited for use with this device.

External Antennas:

Taoglas Part: GW26.0112

Gain: 1.8dBi

Impedance: 50Ω

Le présent appareil est conforme aux CNR d'Industrie Canada applicables aux appareils radio exempts de licence. L'exploitation est autorisée aux deux conditions suivantes: (1) l'appareil ne doit pas produire de brouillage, et (2) l'utilisateur de l'appareil doit accepter tout brouillage radioélectrique subi, même si le brouillage est susceptible d'en compromettre le fonctionnement.

L'exposition à l'énergie radiofréquence. La puissance de sortie rayonnée de cet appareil est conforme aux limites de la FCC/ISDE Canada limites d'exposition aux fréquences radio. Cet appareil doit être utilisé avec une distance minimale de séparation de 20 cm entre l'appareil et le corps d'une personne.

AVERTISSEMENT: Tout changement ou modification non expressément approuvé par le responsable de la conformité pourrait annuler le droit de l'utilisateur à utiliser l'équipement. La mention "IC" devant le numéro de certification radio signifie uniquement que les spécifications techniques d'Industrie Canada ont été respectées.

Cet émetteur radio [IC : 32885-GWV1] a été approuvé par Innovation, Sciences et Développement économique Canada pour fonctionner avec les types d'antennes énumérés ci-dessous, avec le gain maximal autorisé indiqué. Les types d'antennes non inclus dans cette liste et dont le gain est supérieur au gain maximal indiqué pour l'un des types énumérés sont strictement interdits avec cet appareil.

Antennes externes:

Taoglas Part: GW26.0112

Gain: 1.8dBi

Impedance: 50Ω