

DRAPER[®]

550mm

PRECISION MITRE SAW

88192

IMPORTANT: PLEASE READ THESE INSTRUCTIONS CAREFULLY TO ENSURE THE SAFE AND EFFECTIVE USE OF THIS PRODUCT.

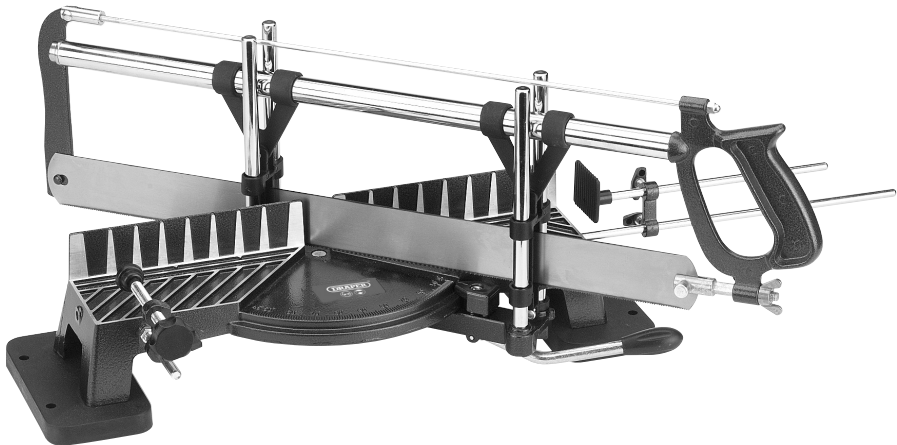

INSTRUCTIONS

These instructions accompanying the product are the original instructions. This document is part of the product, keep it for the life of the product passing it on to any subsequent holder of the product. Read all these instructions before assembling, operating or maintaining this product.

This manual has been compiled by Draper Tools describing the purpose for which the product has been designed, and contains all the necessary information to ensure its correct and safe use. By following all the general safety instructions contained in this manual, it will ensure both product and operator safety, together with longer life of the product itself.

All photographs and drawings in this manual are supplied by Draper Tools to help illustrate the operation of the product.

Whilst every effort has been made to ensure the accuracy of information contained in this manual, the Draper Tools policy of continuous improvement determines the right to make modifications without prior warning.

1. PARTS DRAWING AND COMPONENTS

- ① Vice clamp assembly.
- ② Length stop assembly.
- ③ Cut depth stop.
- ④ Cut depth stop screws.
- ⑤ Base.
- ⑥ Base socket head screws.
- ⑦ Pre-set angle arm.
- ⑧ Pivot pin.
- ⑨ Cursor screw.
- ⑩ Cursor.
- ⑪ Blade tensioning nut.
- ⑫ Pivot screw.
- ⑬ Saw table.
- ⑭ Saw frame handle.
- ⑮ Saw frame guide bar carriers.
- ⑯ Saw blade.
- ⑰ Saw frame carriers.
- ⑱ Saw frame assembly.

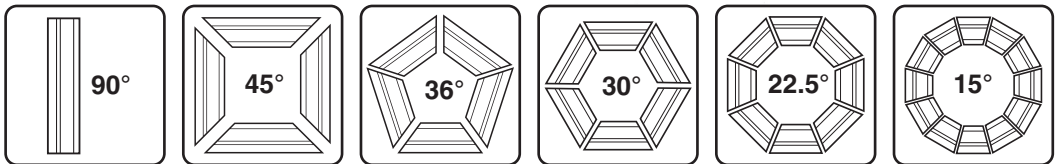
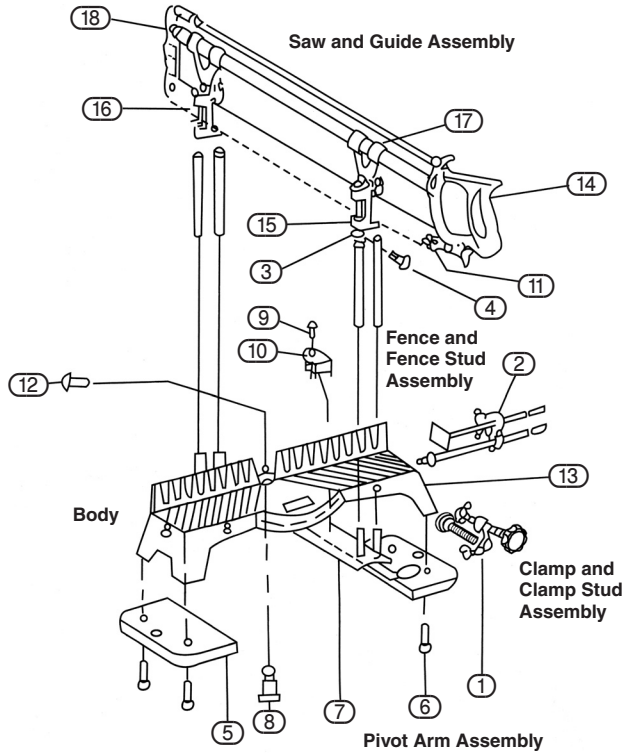

2. IMPORTANT WARNING

- After assembly, test the angles with some scrap timber to ensure the machine is assembled correctly and cutting true.

To get the best use from this mitre saw ensure that:-

- The saw blade is tensioned sufficiently to avoid “whip” which will cause the blade to deviate from a true cut.
- The blade is in line and central to the frame.
- The workpiece is square and true to the base casting.
- Blade tension is released after use.
- You read the instruction leaflet supplied thoroughly before use.

CONTACTS

- **DRAPER TOOLS LIMITED,**
Hursley Road, Chandler's Ford,
Eastleigh, Hampshire. SO53 1YF. U.K.
- **Helpline:** (023) 8049 4344
- **Sales Desk:** (023) 8049 4333
- **Internet:** www.drapertools.com
- **E-mail:** sales@drapertools.com
- **Sales Fax:** (023) 8049 4209
- **General Enquiries:** (023) 8026 6355
- **Service/Warranty Repair Agent**
For aftersales servicing or warranty repairs, please contact the Draper Tools Helpline for details of an agent in your local area.

YOUR DRAPER STOCKIST

SRDH0417

©Published by Draper Tools Limited.

No part of this publication may be reproduced, stored in a retrieval system or transmitted in any form or by any means, electronic, mechanical photocopying, recording or otherwise without prior permission in writing from Draper Tools Ltd.