

DENON

SUPER AUDIO CD PLAYER

DCD-A100

Owner's Manual

Manuel de l'Utilisateur

Manual del usuario

SAFETY PRECAUTIONS



CAUTION
RISK OF ELECTRIC SHOCK
DO NOT OPEN



CAUTION:
TO REDUCE THE RISK OF ELECTRIC SHOCK, DO NOT REMOVE COVER (OR BACK). NO USER-SERVICEABLE PARTS INSIDE. REFER SERVICING TO QUALIFIED SERVICE PERSONNEL.

The lightning flash with arrowhead symbol, within an equilateral triangle, is intended to alert the user to the presence of uninsulated "dangerous voltage" within the product's enclosure that may be of sufficient magnitude to constitute a risk of electric shock to persons.

The exclamation point within an equilateral triangle is intended to alert the user to the presence of important operating and maintenance (servicing) instructions in the literature accompanying the appliance.

WARNING:
TO REDUCE THE RISK OF FIRE OR ELECTRIC SHOCK, DO NOT EXPOSE THIS APPLIANCE TO RAIN OR MOISTURE.

CAUTION:
USE OF CONTROLS OR ADJUSTMENTS OR PERFORMANCE OF PROCEDURES OTHER THAN THOSE SPECIFIED HEREIN MAY RESULT IN HAZARDOUS RADIATION EXPOSURE. THIS PRODUCT SHOULD NOT BE ADJUSTED OR REPAIRED BY ANYONE EXCEPT PROPERLY QUALIFIED SERVICE PERSONNEL.

Lasers Class (IEC 60825-1:2001)

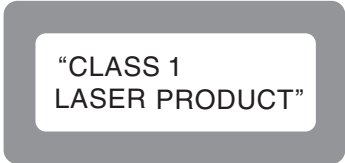

IMPORTANT SAFETY INSTRUCTIONS

1. Read these instructions.
2. Keep these instructions.
3. Heed all warnings.
4. Follow all instructions.
5. Do not use this apparatus near water.
6. Clean only with dry cloth.
7. Do not block any ventilation openings. Install in accordance with the manufacturer's instructions.
8. Do not install near any heat sources such as radiators, heat registers, stoves, or other apparatus (including amplifiers) that produce heat.
9. Do not defeat the safety purpose of the polarized or grounding-type plug. A polarized plug has two blades with one wider than the other. A grounding type plug has two blades and a third grounding prong. The wide blade or the third prong are provided for your safety. If the provided plug does not fit into your outlet, consult an electrician for replacement of the obsolete outlet.
10. Protect the power cord from being walked on or pinched particularly at plugs, convenience receptacles, and the point where they exit from the apparatus.
11. Only use attachments/accessories specified by the manufacturer.
12. Use only with the cart, stand, tripod, bracket, or table specified by the manufacturer, or sold with the apparatus. When a cart is used, use caution when moving the cart/apparatus combination to avoid injury from tip-over.
13. Unplug this apparatus during lightning storms or when unused for long periods of time.
14. Refer all servicing to qualified service personnel. Servicing is required when the apparatus has been damaged in any way, such as power-supply cord or plug is damaged, liquid has been spilled or objects have fallen into the apparatus, the apparatus has been exposed to rain or moisture, does not operate normally, or has been dropped.
15. Batteries shall not be exposed to excessive heat such as sunshine, fire or the like.



CAUTION:

To completely disconnect this product from the mains, disconnect the plug from the wall socket outlet. The mains plug is used to completely interrupt the power supply to the unit and must be within easy access by the user.

PRECAUTION:

Pour déconnecter complètement ce produit du courant secteur, débranchez la prise de la prise murale. La prise secteur est utilisée pour couper complètement l'alimentation de l'appareil et l'utilisateur doit pouvoir y accéder facilement.

PRECAUCIÓN:

Para desconectar completamente este producto de la alimentación eléctrica, desconecte el enchufe del enchufe de la pared. El enchufe de la alimentación eléctrica se utiliza para interrumpir por completo el suministro de alimentación eléctrica a la unidad y debe de encontrarse en un lugar al que el usuario tenga fácil acceso.

FCC INFORMATION
(For US customers)

1. PRODUCT

This product complies with Part 15 of the FCC Rules. Operation is subject to the following two conditions: (1) this product may not cause harmful interference, and (2) this product must accept any interference received, including interference that may cause undesired operation.

2. IMPORTANT NOTICE: DO NOT MODIFY THIS PRODUCT

This product, when installed as indicated in the instructions contained in this manual, meets FCC requirements. Modification not expressly approved by DENON may void your authority, granted by the FCC, to use the product.

3. NOTE

This product has been tested and found to comply with the limits for a Class B digital device, pursuant to Part 15 of the FCC Rules. These limits are designed to provide reasonable protection against harmful interference in a residential installation. This product generates, uses and can radiate radio frequency energy and, if not installed and used in accordance with the instructions, may cause harmful interference to radio communications. However, there is no guarantee that interference will not occur in a particular installation. If this product does cause harmful interference to radio or television reception, which can be determined by turning the product OFF and ON, the user is encouraged to try to correct the interference by one or more of the following measures:

- Reorient or relocate the receiving antenna.
- Increase the separation between the equipment and receiver.
- Connect the product into an outlet on a circuit different from that to which the receiver is connected.
- Consult the local retailer authorized to distribute this type of product or an experienced radio/TV technician for help.

This Class B digital apparatus complies with Canadian ICES-003. Cet appareil numérique de la classe B est conforme à la norme NMB-003 du Canada.



NOTE ON USE / OBSERVATIONS RELATIVES A L'UTILISATION / NOTAS SOBRE EL USO

WARNINGS	AVERTISSEMENTS	ADVERTENCIAS
<ul style="list-style-type: none"> Avoid high temperatures. Allow for sufficient heat dispersion when installed in a rack. Handle the power cord carefully. Hold the plug when unplugging the cord. Keep the unit free from moisture, water, and dust. Unplug the power cord when not using the unit for long periods of time. Do not obstruct the ventilation holes. Do not let foreign objects into the unit. Do not let insecticides, benzene, and thinner come in contact with the unit. Never disassemble or modify the unit in any way. Ventilation should not be impeded by covering the ventilation openings with items, such as newspapers, tablecloths or curtains. Naked flame sources such as lighted candles should not be placed on the unit. Observe and follow local regulations regarding battery disposal. Do not expose the unit to dripping or splashing fluids. Do not place objects filled with liquids, such as vases, on the unit. Do not handle the mains cord with wet hands. When the switch is in the OFF position, the equipment is not completely switched off from MAINS. The equipment shall be installed near the power supply so that the power supply is easily accessible. 	<ul style="list-style-type: none"> Eviter des températures élevées. Tenir compte d'une dispersion de chaleur suffisante lors de l'installation sur une étagère. Manipuler le cordon d'alimentation avec précaution. Tenir la prise lors du débranchement du cordon. Protéger l'appareil contre l'humidité, l'eau et la poussière. Débrancher le cordon d'alimentation lorsque l'appareil n'est pas utilisé pendant de longues périodes. Ne pas obstruer les trous d'aération. Ne pas laisser des objets étrangers dans l'appareil. Ne pas mettre en contact des insecticides, du benzène et un diluant avec l'appareil. Ne jamais démonter ou modifier l'appareil d'une manière ou d'une autre. Ne pas recouvrir les orifices de ventilation avec des objets tels que des journaux, nappes ou rideaux. Cela entraverait la ventilation. Ne jamais placer de flamme nue sur l'appareil, notamment des bougies allumées. Veillez à respecter les lois en vigueur lorsque vous jetez les piles usagées. L'appareil ne doit pas être exposé à l'eau ou à l'humidité. Ne pas poser d'objet contenant du liquide, par exemple un vase, sur l'appareil. Ne pas manipuler le cordon d'alimentation avec les mains mouillées. Lorsque l'interrupteur est sur la position OFF, l'appareil n'est pas complètement déconnecté du SECTEUR (MAINS). L'appareil sera installé près de la source d'alimentation, de sorte que cette dernière soit facilement accessible. 	<ul style="list-style-type: none"> Evite altas temperaturas. Permite la suficiente dispersión del calor cuando está instalado en la consola. Maneje el cordón de energía con cuidado. Sostenga el enchufe cuando desconecte el cordón de energía. Mantenga el equipo libre de humedad, agua y polvo. Desconecte el cordón de energía cuando no utilice el equipo por mucho tiempo. No obstruya los orificios de ventilación. No deje objetos extraños dentro del equipo. No permita el contacto de insecticidas, gasolina y diluyentes con el equipo. Nunca desarme o modifique el equipo de ninguna manera. La ventilación no debe quedar obstruida por haberse cubierto las aperturas con objetos como periódicos, manteles o cortinas. No deberán colocarse sobre el aparato fuentes inflamables sin protección, como velas encendidas. A la hora de deshacerse de las pilas, respete la normativa para el cuidado del medio ambiente. No exponer el aparato al goteo o salpicaduras cuando se utilice. No colocar sobre el aparato objetos llenos de líquido, como jarros. No maneje el cable de alimentación con las manos mojadas. Cuando el interruptor está en la posición OFF, el equipo no está completamente desconectado de la alimentación MAINS. El equipo se instalará cerca de la fuente de alimentación de manera que resulte fácil acceder a ella.

CAUTIONS ON INSTALLATION
PRÉCAUTIONS D'INSTALLATION
EMPLAZAMIENTO DE LA INSTALACIÓN

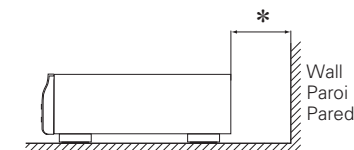
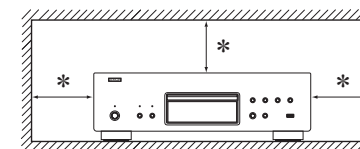

*** For proper heat dispersal, do not install this unit in a confined space, such as a bookcase or similar enclosure.**

- More than 0.1 m is recommended.
- Do not place any other equipment on this unit.

*** Pour permettre la dissipation de chaleur requise, n'installez pas cette unité dans un espace confiné tel qu'une bibliothèque ou un endroit similaire.**

- Une distance de plus de 0,1 m est recommandée.
- Ne placez aucun matériel sur cet appareil.

*** Para la dispersión del calor adecuadamente, no instale este equipo en un lugar confinado tal como una librería o unidad similar.**

- Se recomienda dejar más de 0,1 m alrededor.
- No coloque ningún otro equipo sobre la unidad.

■ Contents

Getting Started	
Main Features	1
Accessories	2
Cautions on Handling	2
Discs	2
Discs Compatible with the DCD-A100	2
Holding Discs	2
Loading Discs	3
Cautions on Loading Discs	3
Cautions on Handling	3
Cautions on Storing Discs	3
Cleaning Discs	3
About the Remote Control	3
Inserting the Batteries	3
Operating Range of the Remote Control	4
Part Names and Functions	4
Front Panel	4
Rear Panel	5
Display	5
Remote Control	6
Connections	
Preparations	6
Connecting Cables	6
Analog Connections	7
Digital Connections	7
USB Port Connections	7
USB Memory device	7
iPod	7
Digital Input Connections	7
Connecting the Power Cord	7
Once Connections are Complete	7
Turning the Power On	7

Playback	
Preparations	8
Setting the top priority playback layer for Super Audio CDs	8
Before Playing a USB or an iPod	8
Operations During Playback	9
Switching the Display's Brightness	9
Switching the Pure Direct Mode	9
CD Playback	9
Playing CDs	9
Displaying text (Super Audio CD only)	9
Playing Repeatedly <Repeat Playback>	9
Playing in Random Order <Random Playback>	9
Playing Tracks in a Specific Order <Program playback>	10
Playback of MP3 and WMA Files	10
Playable MP3 and WMA Formats	10
Playing MP3 and WMA Files	11
iPod® Playback	12
Playing an iPod®	13
Disconnecting an iPod	13
USB Playback	14
Playable USB Memory Formats	14
Playing USB Memory Device	14
Using as a D/A Converter	15
Using the Timer Play Function	15
Troubleshooting	
	16
Specifications	
	17
Index	
	17

Getting Started

Thank you for purchasing this DENON product. To ensure proper operation, please read this owner's manual carefully before using the product. After reading the manual, be sure to keep it for future reference.

Main Features

- 1. Advanced AL32 Processing and High-precision 32bit D/A Converter**
 Equipped with Advanced AL32 Processing, DENON's proprietary analog waveform reproduction technology. We have enhanced the reproducibility of weak signals by expanding 16 bit digital data to 32 bit. The player is also equipped with a high-performance, 32 bit/192 kHz-compatible D/A Converter for analog signal conversion of the digital data expanded with Advanced AL32 Processing.
- 2. Playback of MP3 and WMA files**
 A USB port is mounted on the front panel. MP3/WMA files can be played by connecting a USB Player, USB memory device. Connect your iPod with the USB cable that came with it. Music files in an iPod, USB Player or USB memory device are transmitted via digital signal and can be enjoyed at high audio quality using the DCD-A100's own audio circuitry.
- 3. Advanced S.V.H. Mechanism & Direct Mechanical Ground Construction**
 In the newly-developed Advanced S.V.H. Mechanism, each individual part, including the aluminum die-cast tray, is composed of different metallic materials, each of which was designed for its own specific purpose. This produces outstanding vibration-damping properties, including damping enhancement and diffusion of the resonance point, due to the high mass. The mechanism is designed with a low center of gravity, reducing vibration from the inner area during disc rotation and its structure is also highly resistant to external vibration. The player also utilizes Direct Mechanical Ground Construction, which completely eliminates the impact of internal and external vibration by, for example, locating the power transformer close to the feet. This prevents the transmission of unwanted vibration as well as noise.

Accessories

Check that the following parts come with the product.

- ① Owner's manual 1
- ② Service network list..... 1
- ③ Power cord (Cord length: Approx. 6.2 ft / 1.9 m) 1
- ④ Remote control (RC-1138) 1
- ⑤ R03/AAA battery..... 2
- ⑥ Audio cable (Cord length: Approx. 4.9 ft / 1.5 m)..... 1

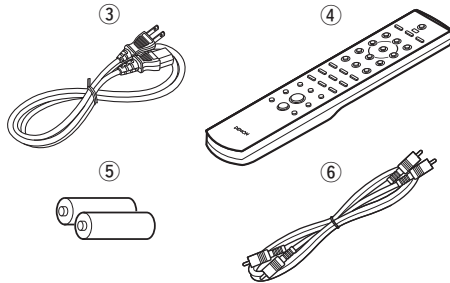

Cautions on Handling

• Before turning the power switch on

Check once again that all connections are correct and that there are no problems with the connection cables.

• When leaving home for long periods of time, be sure to unplug the power cord from the power outlet.

• Proper ventilation

If the unit is left in a room full of the smoke from cigarettes, etc., for long periods of time, the surface of the optical pickup may get dirty, preventing it from receiving the signals properly.

• About condensation

If there is a major difference in temperature between the inside of the unit and its surroundings, condensation may form on parts inside the unit, causing the unit to fail to operate properly.

If this happens, let the unit sit for an hour or two with the power off and wait until there is little difference in temperature before using the unit.

• Cautions on using mobile phones

Using a mobile phone near this unit may result in noise. If that occurs, move the mobile phone away from the unit when it is in use.

• Moving the unit

Turn off the power and unplug the power cord from the power outlet.

Next, disconnect the cables connected to other system units before moving the unit.

• Note that for explanatory purposes the illustrations in these instructions may differ from the actual unit.

Discs

Discs Compatible with the DCD-A100

① Super Audio CDs

Super Audio CDs with the following logos indicated below can be played on this unit.



SUPER AUDIO CD

Stereo Multi-ch

There are three types of Super Audio CDs:

- ① Single layer discs
Single layer Super Audio CD with just an HD layer.
- ② Dual layer discs
Super Audio CD with a double HD layer, offering extended playing time and high sound quality.
- ③ Hybrid discs
Two-layer Super Audio CD with an HD layer and a CD layer.
The signals on the CD layer can be played on a regular CD player.

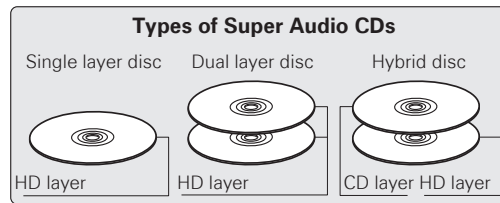

※ What is the HD layer?

The HD layer is a layer of high density signals for Super Audio CDs.

※ What is the CD layer?

The CD layer is the layer of signals that can be read on a regular CD player.

When "Multi-channel" is selected with the **DISC LAYER** button, a downmixed audio is output to the L and R channels.

② Music CDs

Discs marked with the logo at right can be played in this unit.



③ CD-R/CD-RW

NOTE

• Discs in special shapes (heart-shaped discs, octagonal discs, etc.) cannot be played. Do not attempt to play them, as doing so can damage the unit.



• Some discs and some recording formats cannot be played.
• Non-finalized discs cannot be played.

※ What is finalization?

Finalization is the process that makes recorded CD-R/CD-RW discs playable on compatible players.

Holding Discs

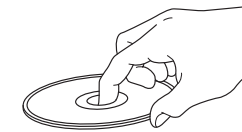

Do not touch the signal surface.

Loading Discs

- Place the disc in the tray, label side up.
- Make sure the disc tray is fully open when inserting the disc.
- Place the discs flat 12 cm discs in the outer tray guide (Figure 1), 8 cm discs in the inner tray guide (Figure 2).

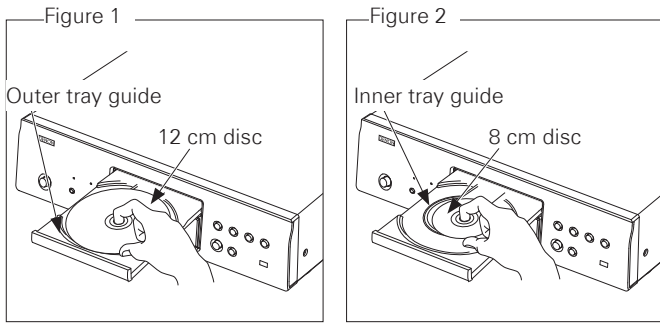

- Place 8 cm discs in the inner tray guide without using an adapter.



- "TRACK0 0m00s" is displayed if a disc that cannot be played is loaded.
- "NO DISC" is displayed if the disc is loaded upside-down or if no disc is loaded.

NOTE

Do not push the disc tray in by hand when the power is turned off. Doing so could damage the set.

Cautions on Loading Discs

- Only load one disc at a time. Loading two or more discs can damage the unit or scratch the discs.
- Do not use cracked or warped discs or discs that have been repaired with adhesive, etc.
- Do not use discs on which the sticky part of cellophane tape or labels is exposed or on which there are traces of where labels have been removed. Such discs can get caught inside the player and damage it.

Cautions on Handling

- Do not get fingerprints, oil or dirt on discs.
- Take special care not to scratch discs when removing them from their cases.
- Do not bend or heat discs.
- Do not enlarge the hole in the center.
- Do not write on the labeled (printed) surface with ball-point pens, pencils, etc., or stick new labels on discs.
- Water droplets may form on discs if they are moved suddenly from a cold place (outdoors for example) to a warm place, but do not try to dry them off using a hairdryer, etc.

Cautions on Storing Discs

- Be sure to remove discs after using them.
- Be sure to store discs in their cases to protect them from dust, scratches, warping, etc.
- Do not store discs in the following places:
 1. Places exposed to direct sunlight for long periods of time
 2. Dusty or humid places
 3. Places exposed to heat from heaters etc.

Cleaning Discs

- If there are fingerprints or dirt on a disc, wipe them off before using the disc. Fingerprints and dirt can impair sound quality and cause interruptions in playback.
- Use a commercially available disc cleaning set or a soft cloth to clean discs.

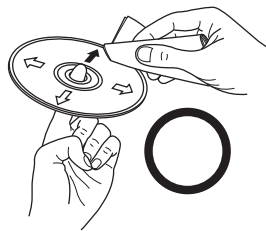

Gently wipe the disc from the inside towards the outside.

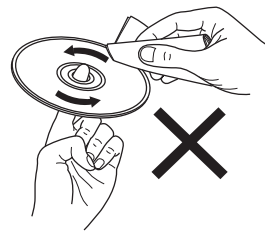

Do not wipe in a circular motion.

NOTE

Do not use record spray, antistatic agents, benzene, thinner or other solvents.

About the Remote Control

Inserting the Batteries

- ① Remove the rear cover of the remote control.
- ② Set two R03/AAA batteries in the battery compartment in the indicated direction.

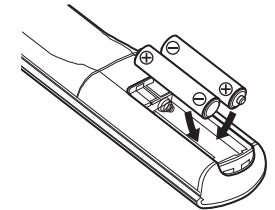
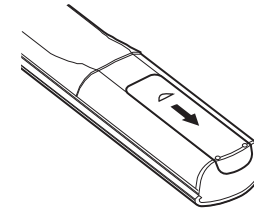

- ③ Put the rear cover back on.

NOTE

- Replace the batteries with new ones if the set does not operate even when the remote control is operated close to the unit.
- The supplied batteries are only for verifying operation.
- Insert the batteries in the proper direction, following the "⊕" and "⊖" marks in the battery compartment.
- To prevent damage or leakage of battery fluid:
 - Do not use a new battery with an old one.
 - Do not use two different types of batteries.
 - Do not attempt to charge dry batteries.
 - Do not short-circuit, disassemble, heat or dispose of batteries in a fire.
- If the battery fluid leaks carefully wipe the fluid off the inside of the battery compartment and insert new batteries.
- Remove the batteries from the remote control if it will not be used for a long time.
- Dispose of batteries in accordance with local regulations on battery disposal.

About the Remote Control

Operating Range of the Remote Control

Operate the remote control while pointing it at the remote sensor.

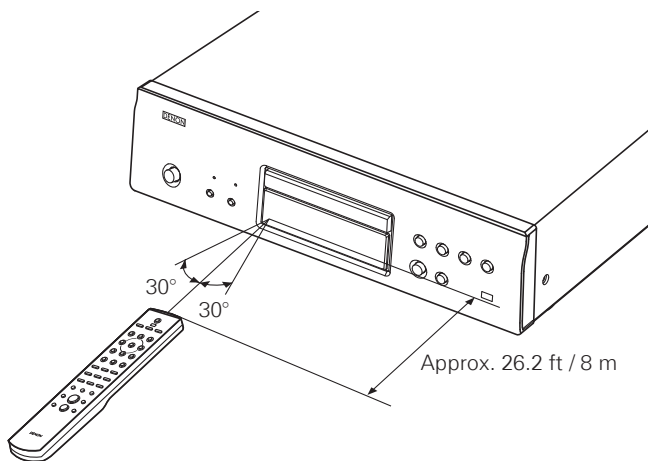

NOTE

The set may function improperly or the remote control may not operate if the remote control sensor is exposed to direct sunlight or strong artificial light from a fluorescent or infrared light.

Part Names and Functions

For buttons not explained here, see the page indicated in parentheses ().

Front Panel

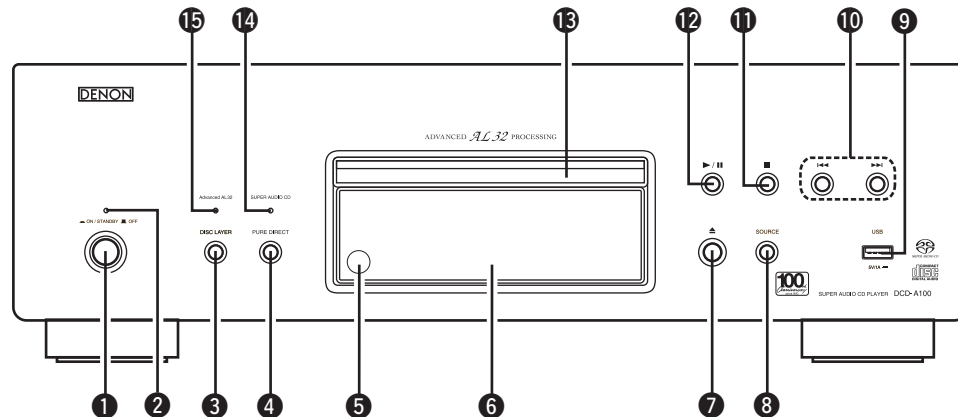

- 1 Power switch (▲ON/STANDBY ■OFF)(8)
- 2 Power indicator(8)
 - Power "ON" Green
 - Standby Red
 - Power "OFF" Off
- 3 DISC LAYER button(8)
- 4 PURE DIRECT button(9)
- 5 Remote control sensor(4)
- 6 Display(5)
- 7 Disc tray open/close button (▲)(3)
- 8 SOURCE button(8)
- 9 USB port (USB)(8)
- 10 Reverse-skip/Forward-skip buttons (|◀◀, ▶▶|)(9)
- 11 Stop button (■)(9)
- 12 Play/Pause button (▶/||)(9)
- 13 Disc tray(3)
- 14 SUPER AUDIO CD indicator

If the unit is one of the following states, this indicator lights.

 - The super audio CD is inserted.
 - The layer mode of the super audio CD is set to "STEREO" or "MULTI."
- 15 Advanced AL32 Processing indicator

If the unit is one of the following states, the Advanced AL32 Processing is enabled and this indicator lights.

 - CD is inserted.
 - The unit is in MP3, WMA, or external input mode.
 - The layer mode of the super audio CD is set to "CD."

Rear Panel

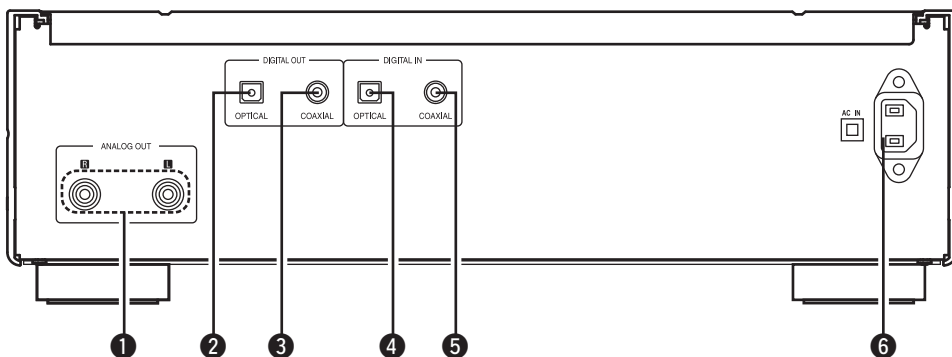

- ① ANALOG OUT connectors (7)
- ② DIGITAL OUT OPTICAL connector (7)
- ③ DIGITAL OUT COAXIAL connector (7)
- ④ DIGITAL IN OPTICAL connector (7)
- ⑤ DIGITAL IN COAXIAL connector (7)
- ⑥ AC inlet (AC IN) (7)

Display

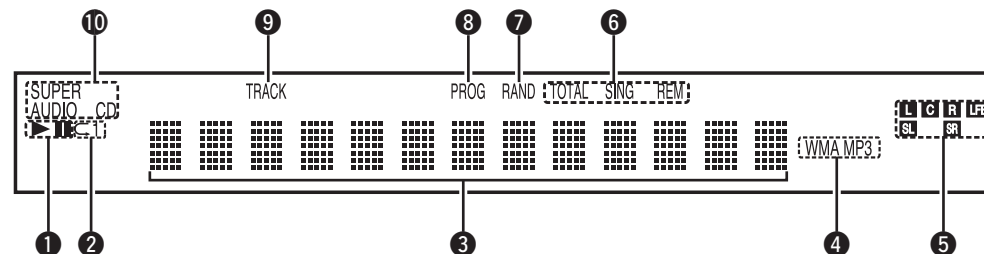

① Playback mode indicators

- ▶ :During Playback
- ⏸ :During pause

② Repeat mode indicators

The display switches as follows each time the **REPEAT** button on the remote control unit is pressed.

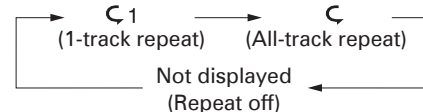

③ Information display

Various information is displayed here, depending on the operation mode.

④ Playback format indicators

NOTE

In FOLDER mode, the "MP3" or "WMA" indicator flashes.

⑤ Playback signal channel indicator

- L : Front left LFE : Subwoofer
- C : Center SL : Surround left
- R : Front right SR : Surround right

⑥ Time display indicator

- SING REM** : Lights up when displaying the remaining time in single-track playback.
- TOTAL REM** : Lights up when displaying the remaining time in all-track playback.

⑦ Random indicator

Lights up during random playback.

⑧ Program indicator

Lights up during program playback.

⑨ Track number indicator

Lights up when displaying the track number.

⑩ Playback media indicator

Part Names and Functions

Remote Control

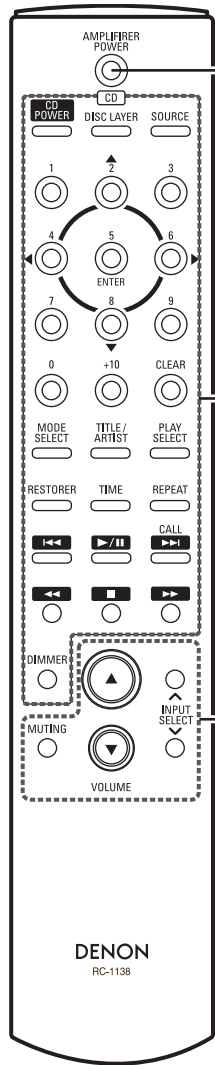

Amplifier operating buttons

The buttons can be used to operate an amplifier supported by the supplied remote control unit (such as the PMA-A100). See the Owner's Manual of the amplifier for information on how to operate it.

CD player operating buttons

CD POWER button(8)
DISC LAYER button(8)
SOURCE button(8)
Number buttons (0 ~ 9, +10)(9)
Cursor buttons (Δ ▽ ◀ ▶)(10)
ENTER button(10)
CLEAR button(10)
MODE SELECT button(10)
TITLE/ARTIST button(10)
PLAY SELECT button(9)
RESTORER button(12)
TIME button(9)
REPEAT button(9)
Reverse-skip button (◀◀)(9)
Play/Pause button (▶/)(8)
Forward-skip (▶▶) / CALL button(9, 10)
Fast-reversing button (◀◀)(9)
Stop button (■)(9)
Fast-forwarding button (▶▶)(9)
DIMMER button(9)

Amplifier operating buttons

The buttons can be used to operate an amplifier supported by the supplied remote control unit (such as the PMA-A100). See the Owner's Manual of the amplifier for information on how to operate it.



- The supplied remote control can operate DENON amplifiers.
- When using it, also refer to the operating instructions of the other devices.
- The remote control may not operate some devices.

Connections

Connections for all compatible audio signal formats are described in this owner's manual. Please select the type of connections corresponding to the equipment you are connecting.

NOTE

- Do not plug in the power cord until all connections have been completed.
- When making connections, also refer to the owner's manual of the other components.
- Be sure to connect the left and right channels properly (left with left, right with right).
- Do not bundle power cords together with connection cables. Doing so can result in humming or noise.

Preparations

Connecting Cables

Select the cables according to the equipment being connected.

Audio cables

Analog connections (stereo)



Audio cable (supplied)

Optical digital connections



Optical cable (sold separately)

Coaxial digital connections



Coaxial digital cable (sold separately)

iPod connections



iPod cable (sold separately)

Analog Connections

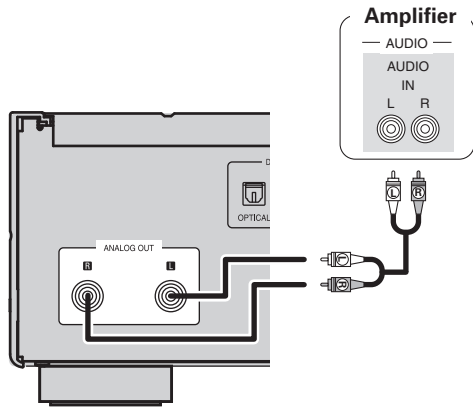

Digital Connections

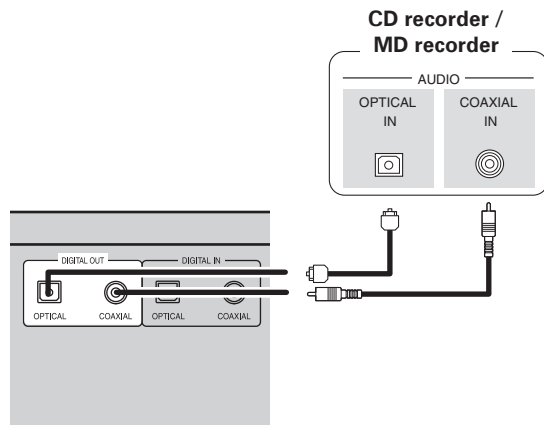

❑ When connecting the optical digital output connector with an optical transmission cable (sold separately)



Remove the protective cap, match the shapes then insert firmly all the way in.

🔧 Store the protective cap in a safe place so as not to lose it, and use it when not using the terminal.

USB Port Connections

USB Memory Device

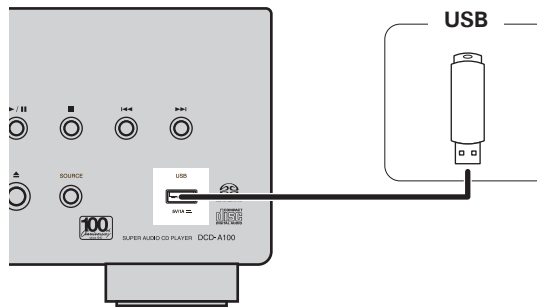

NOTE

- Do not use an extension cable when connecting a USB Memory device.
- A computer may not be connected to and operate the DCD-A100's via its USB port.
- For details about USB memory devices, see "Playable USB Memory Formats" (🔗 page 14).

iPod

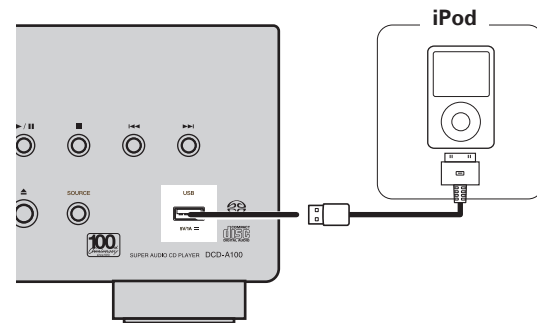

- To connect an iPod to the DCD-A100, use the USB cable supplied with the iPod.
- Players such as the iPod touch, classic and nano sold from generation 5 can be played. For details, check the Web (www.denon.com).

Digital Input Connections

The DCD-A100 can be used as a D/A converter (🔗 page 15).

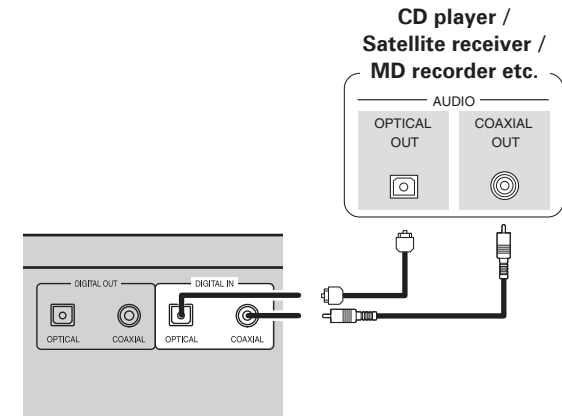

Connecting the Power Cord

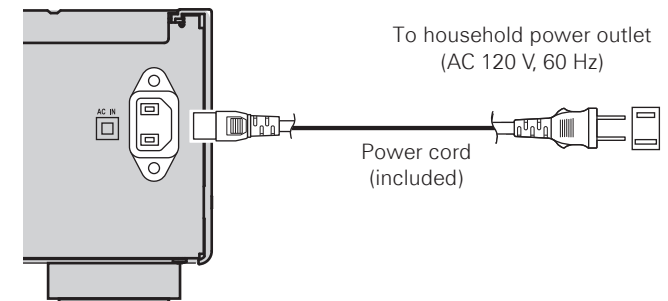

NOTE

- Insert the plugs securely. Loose connections will result in the generation of noise.
- Do not unplug the power cord while the set is operating.

Once Connections are Complete

Turning the Power On (🔗 page 8)



Operations During Playback

Switching the Display's Brightness

Press [DIMMER].

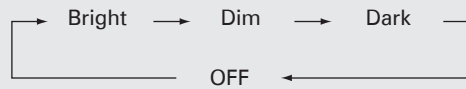

※ The display's brightness switches each time the button is pressed.

Switching the Pure Direct Mode

In the stop mode, press <PURE DIRECT>.

※ In Pure Direct Mode, the DCD-A100 is in the following state:

- Display: OFF
- Digital output: OFF

CD Playback

Playing CDs

1 Playback preparation (☞ page 8 “Setting the top priority playback layer for Super Audio CDs”).

2 Press ►/II.
The “►” indicator lights and playback begins.

❑ Stopping Playback

Press ■.

❑ Pausing

Press ►/II.

The “II” indicator lights.

※ To resume playback, press ►/II.

❑ Fast-Forwarding and Fast-Reversing (searching)

During playback, press and hold in [◀◀, ▶▶].

❑ Moving to the Beginning of Tracks (skipping)

During playback, press I◀◀, ▶▶I.

※ The disc is skipped the number of tracks equal to the number of times the button is pressed.

※ When pressed once in the return direction, playback returns to the beginning of the currently playing track.

❑ Playing a Specific Track

(Remote Control Unit Only)

Press [NUMBER] (0 ~ 9, +10) to select the track.

[Example] : Track 4 : [4]

[Example] : Track 12 : [+10], [2]

[Example] : Track 20 : [+10], [+10], [0]

Displaying Text (Super Audio CD only)

- The player can display the textual information of Super Audio CDs that contain it while either stopped or playing.
- The album title, artist name and track titles can be displayed.
- The player can display capital and small letters, numbers and some symbols.

In the stop mode, press [TITLE/ARTIST].

The album title scrolls on the display ← → The album's artist name scrolls on the display

※ The display switches each time the button is pressed.



Press [TIME] to switch to the display of the recorded time while text information is being displayed.

Playing Repeatedly <Repeat Playback>

Press [REPEAT].

Playback in the respective repeat mode starts.

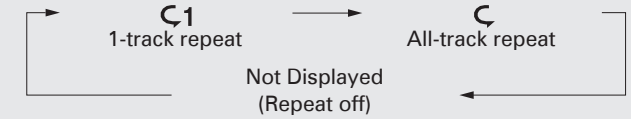

[Selectable items]

C 1 (1-track repeat) : Only 1 track is played repeatedly.

C (All-track repeat) : All tracks are played repeatedly.

Not Displayed (Repeat off) : Normal playback resumes.

Playing in Random Order <Random Playback>

1 In the stop mode, press [PLAY SELECT] until “RAND” lights.

※ Each time [PLAY SELECT] is pressed, the display changes as follows:

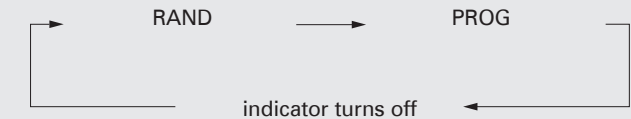

2 Press ►/II.
The tracks start playing in random order.

❑ Stopping Random Playback

While stopped, press [PLAY SELECT] twice.

The “RAND” indicator turns off.

NOTE

Direct searching is not possible during random playback.

Symbols used to indicate buttons in this manual

Button located on both the main unit and the remote control → **BUTTON**
 Button only on the main unit → **<BUTTON>**
 Button only on the remote control → **[BUTTON]**

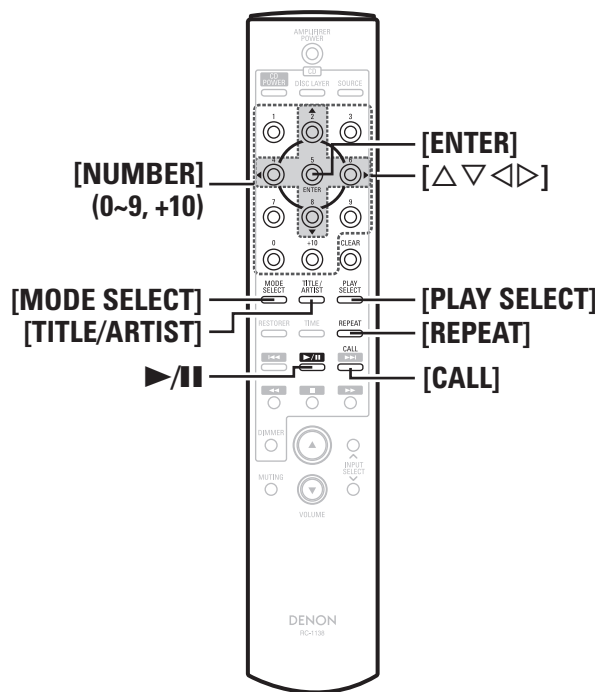

CD Playback

Playing Tracks in a Specific Order
<Program playback>

Up to 20 tracks can be programmed.

1 In the stop mode, press **[PLAY SELECT]** until “PROG” is lights.

※ Each time **[PLAY SELECT]** is pressed, the display changes as follows:

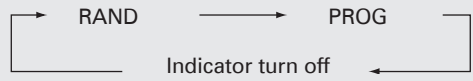

2 Use **[NUMBER]** (0 ~ 9, +10) to select the tracks.
[Example]
 To program tracks 3, 12, 7 to play in that order:
 Press **[3]**, **[+10]**, **[2]**, **[7]**.

3 Press **▶/II**.
 Playback starts in the programmed order.

- Checking the order of the programmed tracks**
 While stopped, press **[CALL]**.
 The track numbers are displayed in the programmed order each time the button is pressed.
- To clear the last track programmed**
 While stopped, press **[CLEAR]**.
 The last track programmed is cleared each time the button is pressed.
- Clearing the all programmed track**
 While stopped, press **[PLAY SELECT]**.

- REPEAT**
 • If **[REPEAT]** is pressed during program playback, the tracks are played repeatedly in the programmed order.
 • Programmed playback is not possible with MP3/WMA discs.

Playback of MP3 and WMA Files

There are many music distribution sites on the Internet allowing you to download music files in MP3 or WMA (Windows Media® Audio) formats. The music (files) downloaded from such sites can be stored on CD-R or CD-RW discs and played on the DCD-A100.

“Windows Media” and “Windows” are registered trademarks or trademarks of Microsoft Corporation in the United States and other countries.

Playable MP3 and WMA Formats

CD-R and CD-RW discs created in the format described below can be played.

Writing software format

- ISO9660 level 1
- ※ When written in other formats, it may not be possible to play the disc properly.

Maximum number of playable files and folders

Total number of folders and files : 1000
 Number of folders : 255

File formats

- MP3 (MPEG-1 Audio Layer-3)
- WMA (Windows Media Audio)



Tag data

ID3-Tags (Ver. 1.x and 2.x)
 META-Tags
 (Compatible with title, artist and album names)

Playable MP3/WMA file			
File format	Sampling frequency	Bit rate	Extension
MP3	32, 44.1, 48 kHz	32 ~ 320 kbps	.mp3
WMA	32, 44.1, 48 kHz	64 ~ 160 kbps	.wma



- Only music files that are not copyright-protected can be played on this set.
- Be sure to give files the extension ".MP3" or ".WMA". Files with any other extensions or with no extensions cannot be played.
- In accordance with copyright laws, recordings you have made should only be used for your personal enjoyment and may not be used in other ways without permission of the copyright holder.

Folder mode and disc mode settings

Press **[MODE SELECT]** to switch the range of files to be played.

• **Folder mode**

The "WMA" or "MP3" indicator flashes.
 The files in the selected folder are played.

• **Disc mode**

The "WMA" or "MP3" indicator lights.
 All the files on the disc are played.

Playing MP3 and WMA Files

1 Load a CD-R or CD-RW disc containing music files in the MP3 or WMA formats into the disc tray (☞ page 3).

2 Press **[MODE SELECT]** to select the folder mode or disc mode.

※ Refer to "Folder mode and disc mode settings" (☞ page 11).

3 Press **▶/II**.
 Playback starts.

Changing the folder to be played

Use **[Δ, ▽]** to select the desired folder, and then press **[ENTER]**.

Changing the file to be played

Use **[<, >]** to select the desired file, and then press **[ENTER]**.



When a folder is selected, playback switches to the first track of the selected folder.

Switching the Display

During playback, press **[TITLE/ARTIST]**.



※ With the DCD-A100, the folder and file names can be displayed like titles. Up to 11 characters consisting of numbers, letters and the underscore can be displayed. Characters that cannot be displayed are replaced with asterisks.

※ The player can display the following characters:

A ~ Z | a ~ z | 0 ~ 9
 ! " # \$ % & : ; < > ? @ \ [] _ ` | { } ~ ^ ' () * + , - . / = (space)

Listening to MP3 or WMA files in random order (Random playback)

1 Press **[MODE SELECT]** to select the disc mode.

※ Refer to "Folder mode and disc mode settings" (☞ page 11).

2 While stopped, press **[PLAY SELECT]**.
 The "RAND" indicator lights.

3 Press **▶/II** or **[ENTER]**.
 Tracks are selected and played automatically in random order.

Canceling random playback

While stopped, press **[PLAY SELECT]**.
 • The "RAND" indicator turns off.

Listening to MP3 or WMA files repeatedly (Repeat folder/disc playback)

1 Press **[MODE SELECT]** to select the folder mode or disc mode.

※ Refer to "Folder mode and disc mode settings" (☞ page 11).

2 Press **[REPEAT]** to select the repeat mode.
 Playback in the respective repeat mode starts.

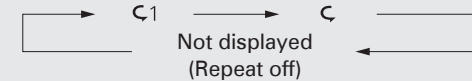

3 Press **▶/II**.
 Either the files in the selected folder or all the files on the disc are played repeatedly.

Canceling repeat folder/disc playback

Press **[REPEAT]** until the "C" indicator turns off.



Playing an iPod®

1 Playback preparation (☞ page 8 “Before Playing USB or an iPod”).

2 Press **[MODE SELECT]** to select the display mode.
The mode switches each time the button is pressed.

Display mode		Browse mode	Remote mode
Display location		Main unit display	iPod display
Playable files	Audio file	○	○
	Video file	×	○
Active buttons	Remote control and Main unit (DCD-A100)	○	○
	iPod	×	○

3 Use **[△▽]** to select the item, then press **[ENTER]** or **[▷]** to select the music file to be played.

4 Press **▶/||**.
Playback starts.

Remote control unit and iPod button relations

Remote control unit buttons	iPod buttons	Operation on the DCD-A100
▶/	▶/	Plays the track ※ Play/Pause in remote mode
◀◀, ▶▶	◀◀, ▶▶	Plays the track from the beginning / Plays the next track
◀◀, ▶▶ (Press and hold) ◀◀, ▶▶	◀◀, ▶▶ (Press and hold)	Fast reverses the track / Fast forwards the track
△, ▽	Click Wheel	Selects an item
ENTER or ▷	Select	Enters the selection or plays the track
MODE SELECT	-	Switches between the browse mode and the remote mode
REPEAT	-	Switches the repeat function
PLAY SELECT	-	Switches the shuffle function
◀	MENU	Displays the menu or return to the previous menu

NOTE

- DENON will accept no responsibility whatsoever for any loss of iPod data.
- Depending on the type of iPod and the software version, some functions may not operate.

To Switch the Display (Browse mode only)

During playback, press **[TITLE/ARTIST]**.
The display switches each time the button is pressed.



Switching the Time Display

Press **[TIME]**.

Playback with the RESTORER function

See page 12 “Playback with the RESTORER function” for Owner’s Manual.

Disconnecting an iPod

1 Press **■**.

2 Disconnect the iPod cable from the USB port.



Symbols used to indicate buttons in this manual

Button located on both the main unit and the remote control → **BUTTON**
 Button only on the main unit → **<BUTTON>**
 Button only on the remote control → **[BUTTON]**

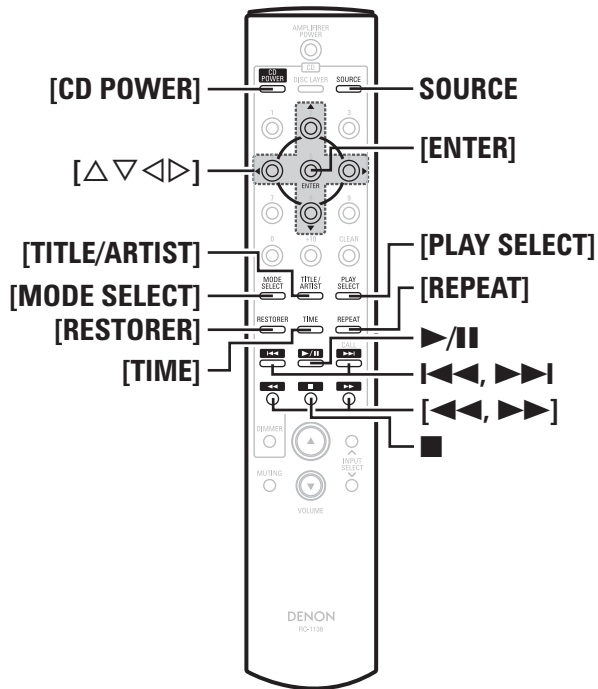
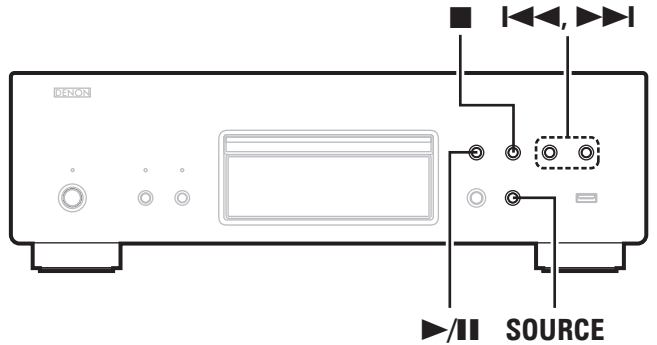

USB Playback

Playable USB Memory Formats

Files created in the following formats and stored on a USB memory device can be played.

USB-Compatible File Systems

"FAT16" or "FAT32"

※ If the USB memory device is divided into multiple partitions, only the top drive can be selected.

Maximum number of playable files and folders

Maximum number of files in a folder: 255

Maximum number of folders: 255

File Format

MP3 (MPEG-1 Audio Layer-3)

WMA (Windows Media Audio)

Tag Data

ID3-Tags (Ver.1.x and 2.x)

META-Tags

(Compatible with title, artist and album names)

Playable MP3/WMA file			
File format	Sampling frequency	Bit rate	Extension
MP3	32, 44.1, 48 kHz	32 ~ 320 kbps	.mp3
WMA	32, 44.1, 48 kHz	64 ~ 192 kbps	.wma



Only music files that are not copyright-protected can be played on this set.

※ Contents downloaded from pay sites on the Internet are copyright protected. Also, files encoded in WMA format when ripped from a CD, etc., on a computer may be copyright protected, depending on the computer's settings.

Playing USB Memory Devices

1 Playback preparation ("Before Playing a USB or an iPod" (page 8)).

2 Press **[MODE SELECT]** to select the folder mode or disc mode.

※ Refer to "Folder mode and disc mode settings" (page 11).

3 Press **▶/||**. Playback starts.

❑ To Switch the Folder or File During Playback

• Folder

Use **[Δ, ▽]** to select the folder, then press **[ENTER]**.

• File

Use **[◀, ▶]** to select the file, then press **[ENTER]**.

Use **◀◀, ▶▶** to select the file.

※ The file numbers are set automatically when the USB memory device is loaded.

❑ Stopping Playback

Press **■**.

❑ Pausing

Press **▶/||**.

The "||" is displayed.

※ To resume playback, press **▶/||**.

❑ Fast-Forwarding and Fast-Reversing (searching)

During playback, press and hold in **◀◀, ▶▶**.

USB Playback

❑ **Playing Repeatedly**

Press [REPEAT].

❑ **Playing in Random Order**

While stopped, press [PLAY SELECT].

❑ **Switching the Display**

During playback, press [TITLE/ARTIST].

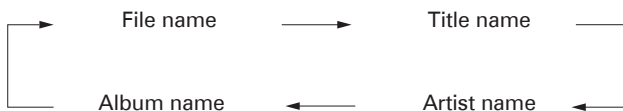

※ The player can display the following characters:

A ~ Z a ~ z 0 ~ 9

! " # \$ % & ; : < > ? @ \ [] _ ` | { } ~ ^ ' () * + , - . / = (space)

❑ **Switching the Time Display**

Press [TIME].

NOTE

- DENON will take no responsibility whatsoever for any loss or damage to data on a USB memory device when using it connected to the DCD-A100.
- USB memory devices will not work via a USB hub.
- DENON does not guarantee that all USB memory devices will operate or be supplied power. When using a USB portable hard disk that can draw power from an AC adapter, we recommend using the AC adapter.

Using as a D/A Converter

Press **SOURCE** to select “EXT IN COAX” or “EXT IN OPT”.

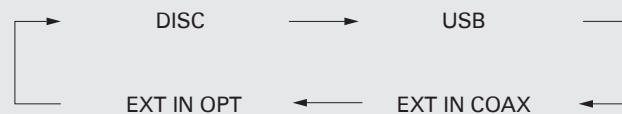

※ “EXT IN ○○ k” is displayed according to the sampling frequency of the external input.

※ If the sampling frequency cannot be detected, the display flashes.

NOTE

- Linear PCM signals with sampling frequencies of 32kHz, 44.1kHz, 48kHz, 64kHz, 88.2kHz, 96kHz, 128kHz, 176.4kHz and 192kHz can be input to the DCD-A100. Do not input non-PCM signals, such as CD-ROM, Dolby Digital, and DTS. This causes noise and could damage the speakers.
- If the sampling frequency switches, such as from A mode to B mode in a CS broadcast, muting may operate for 1-2 seconds, cutting the sound.

Using the Timer Play Function

1 Turn on the power of the connected components.

2 Switch the amplifier's function to input from the connected main unit.

3 Load a disc or connect a USB memory device or iPod.

4 Set the audio timer for the desired times.

※ Refer also to the owner's manual of the audio timer.

5 Turn the timer “ON”.

The power of the components connected to the timer turns off.

※ When the set time is reached, the power of the different components automatically turns on and playback starts.

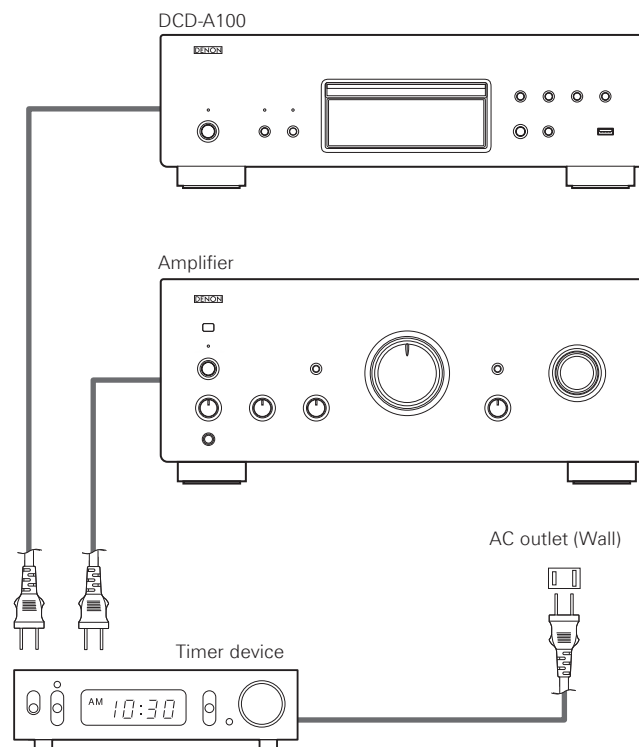

Troubleshooting

If a problem occurs, first check the following:

1. Are the connections correct?
2. Is the set being operated as described in the owner's manual?

If this unit does not operate properly, check the items listed in the table below. If the problem persists there may be a malfunction.

In this case, disconnect the power immediately and contact the retail outlet.

[General]

Symptom	Cause	Countermeasure	Page
Disc tray does not open.	• The power is not on.	• Turn on the power.	8
"NO DISC" is displayed even though a disc is loaded.	• The disc is not properly loaded.	• Reload the disc.	3
"TRACK0 0m00s" is displayed even though a disc is loaded.	• The loaded disc is not a CD.	• Load a CD.	3
Playback does not start even when the ►/ button is pressed.	• The disc is dirty or scratched.	• Wipe the dirt off the disc or replace the disc.	3
No sound is produced or sound is distorted.	• The output cables are not properly connected to the amplifier. • The amplifier's function setting or adjustments are not right.	• Check the connections.	7
		• Check the amplifier's functions and controls and adjust as necessary.	–
A specific section of a disc does not play properly.	• The disc is dirty or scratched.	• Wipe the dirt off the disc or replace the disc.	3
Programmed playback is not possible.	• The tracks have not been programmed properly. • Programmed playback is not possible with MP3 and WMA files.	• Program properly.	10
		• Use a CD.	10
A CD-R or CD-RW disc cannot be played.	• The disc has not been finalized. • The recording conditions and/or the quality of the disc itself are poor.	• Finalize the disc then play it.	2
		• Use a properly recorded disc.	2

Symptom	Cause	Countermeasure	Page
The set does not operate properly when the remote control is operated.	• The batteries are dead.	• Replace the batteries with new ones.	3
	• The remote control unit is too far from the set.	• Move the remote control unit closer to the set.	4
File recorded in MP3 or WMA formats cannot be played.	• You have selected a copyright-protected WMA file or a file that cannot be played normally.	• Use the ◀, ▶ button on the remote control unit to select a different file.	11

[iPod]

Symptom	Cause	Countermeasure	Page
The iPod cannot be played.	• Cable is not properly connected.	• Reconnect.	7

[USB]

Symptom	Cause	Countermeasure	Page
When a USB memory device is connected, "NO DEVICE" is displayed.	• The set cannot recognize a USB memory device.	• Check the connection.	7
	• A USB memory device not conforming to mass storage class or MTP standards is connected.	• Connect a USB memory device conforming to mass storage class or MTP standards.	–
	• A USB memory device that the set cannot recognize is connected.	• This is not a malfunction. DENON does not guarantee that all USB memory devices will operate or receive power.	–
Files on a USB memory device cannot be played.	• The USB memory device is connected via USB hub.	• Connect the USB memory device directly to the USB port.	–
	• The USB memory device is in a format other than FAT16 or FAT32.	• Set the format to FAT16 or FAT32. For details, refer to the USB memory device's operating instructions.	–
Files are stored in a non-compatible format.	• The USB memory device is divided into multiple partitions.	• When divided into multiple partitions, only files stored in the top partition can be played.	–
	• You are attempting to play a file that is copyright protected.	• Record the files in a compatible format.	14
		• Files that are copyright protected cannot be played on this set.	14

Specifications

Audio performance

	[Super Audio CD]	[CD]
• Analog output		
Channels:	2 channels	2 channels
Playable frequency range:	2 Hz ~ 100 kHz	2 Hz ~ 20 kHz
Playable frequency response:	2 Hz ~ 50 kHz (-3 dB)	2 Hz ~ 20 kHz
S/N:	119 dB (Audible range)	119 dB
Dynamic range:	114 dB (Audible range)	100 dB
Harmonic distortion:	0.0008 % (1 kHz, Audible range)	0.0017 % (1 kHz)
Wow & flutter:	Below measurable limits	Below measurable limits
Output level:	2.0 V (10 kΩ/kohms)	2.0 V (10 kΩ/kohms)
Signal type:	1-bit DSD	16-bit linear PCM
Sampling frequency:	2.822 MHz	44.1 kHz
Usable discs:	Super Audio CD	Compact Disc
• Digital output		
Coaxial:	-	0.5 V _{p-p} / 75 Ω/ohms
Optical:	-	-15 ~ -21 dBm
Emission wavelength:	-	660 nm

General

Power supply:	AC 120 V, 60 Hz
Power consumption:	33 W
	Standby: 0.3 W or less
Maximum external dimensions:	17 3/32 (W) x 5 25/64 (H) x 13 15/64 (D) inches (434 (W) x 137 (H) x 336 (D) mm)
Weight:	31 lbs 15.47oz (14.5 kg)

Remote control unit (RC-1138)

Remote control method:	Infrared pulse method
Power supply:	R03/AAA Type (two batteries)
Maximum external dimensions:	1 47/64 (W) x 9 11/64 (H) x 55/64 (D) inches (44 (W) x 233 (H) x 22 (D) mm)
Weight:	5.82oz (165 g) (including batteries)

※ For purposes of improvement, specifications and design are subject to change without notice.

Index

A	O
All-track repeat9	Optical cable6
Analog connections7	Priority playback layer8
Audio cable6	
B	P
Batteries3	Playing CDs9
	Playing in random order9
C	Playing repeatedly9
Connecting cables6	Playing tracks in a specific order10
CD-R/CD-RW2	Power cord7
CD layer2	Program playback10
Coaxial digital cable6	Pure direct mode9
D	R
D/A converter15	Random playback9
Digital connections7	Repeat playback9
Digital input connections7	Remote control unit6
Disc mode11	RESTORER12
Display5	S
Display's brightness9	Searching9
Dual layer disc2	Single-track repeat9
E	Single layer disc2
Extension11	Skipping9
F	Stopping playback9
Fast-forwarding9	Stopping playback temporarily9
Fast-reversing9	Super Audio CD2
File format11	T
Finalization2	Timer play function15
Folder mode11	U
H	USB memory device14
HD layer2	W
Hybrid disc2	WMA11
I	
iPod12	
M	
Moving to the beginning of tracks9	
MP311	
Music CDs2	



DENON

www.denon.com

Denon Brand Company, D&M Holdings Inc.
Printed in Japan 5411 10564 001D

