



DRAPER[®]

360° ROTATING SELF-LEVELLING

LASER LEVEL KIT

88640



These instructions accompanying the product are the original instructions. This document is part of the product, keep it for the life of the product passing it on to any subsequent holder of the product. Read all these instructions before assembling, operating or maintaining this product.

This manual has been compiled by Draper Tools describing the purpose for which the product has been designed, and contains all the necessary information to ensure its correct and safe use. By following all the general safety instructions contained in this manual, it will ensure both product and operator safety, together with longer life of the product itself.

All photographs and drawings in this manual are supplied by Draper Tools to help illustrate the operation of the product.

Whilst every effort has been made to ensure the accuracy of information contained in this manual, the Draper Tools policy of continuous improvement determines the right to make modifications without prior warning.

1. TITLE PAGE

1.1 INTRODUCTION:

USER MANUAL FOR: 360° Rotating Self-Levelling Laser Level Kit

Stock No: 88640

Part No: LLK3

1.2 REVISIONS:

Date first published June 2017

As our user manuals are continually updated, users should make sure that they use the very latest version.

Downloads are available from: <http://drapertools.com/manuals>

Draper Tools Limited
Hursley Road
Chandler's Ford
Eastleigh
Hampshire
SO53 1YF
UK

Website: drapertools.com

Product Helpline: +44 (0) 23 8049 4344

General Fax: +44 (0) 23 8026 0784

1.3 UNDERSTANDING THIS MANUALS SAFETY CONTENT:

WARNING! – Information that draws attention to the risk of injury or death.

CAUTION! – Information that draws attention to the risk of damage to the product or surroundings.

1.4 COPYRIGHT © NOTICE:

Copyright © Draper Tools Limited.

Permission is granted to reproduce this publication for personal and educational use only. Commercial copying, redistribution, hiring or lending is prohibited.

No part of this publication may be stored in a retrieval system or transmitted in any other form or means without written permission from Draper Tools Limited.

In all cases this copyright notice must remain intact.

2. CONTENTS

1. TITLE PAGE	
1.1 INTRODUCTION	2
1.2 REVISION HISTORY	2
1.3 UNDERSTANDING THIS MANUAL	2
1.4 COPYRIGHT NOTICE.....	2
2. CONTENTS	
2.1 CONTENTS	3
3. GUARANTEE	
3.1 GUARANTEE	4
4. INTRODUCTION	
4.1 SCOPE.....	5
4.2 SPECIFICATION	5
4.3 HANDLING AND STORAGE	5
5. HEALTH AND SAFETY INFORMATION	
5.1 GENERAL SAFETY INSTRUCTIONS FOR LASER USE.....	6
6. TECHNICAL DESCRIPTION	
6.1 IDENTIFICATION	7
7. UNPACKING AND CHECKING	
7.1 PACKAGING	8
7.2 WHAT'S IN THE BOX?	8
8. LASER LEVEL BATTERY INSTALL	
8.1 LASER LEVEL BATTERY INSTALLATION	9
9. OPERATION AND USE	
9.1 OPERATION AND USE.....	10
9.2 SELF-LEVELLING LASER LEVEL.....	10
10. EXPLANATION OF SYMBOLS	
10.1 EXPLANATION OF SYMBOLS	11
11. DISPOSAL	
11.1 DISPOSAL.....	11
DECLARATION OF CONFORMITY	ENCLOSED

3. GUARANTEE

3.1 GUARANTEE

Draper tools have been carefully tested and inspected before shipment and are guaranteed to be free from defective materials and workmanship.

Should the tool develop a fault, please return the complete tool to your nearest distributor or contact:

Draper Tools Limited, Chandler's Ford, Eastleigh, Hampshire, SO53 1YF. England.

Telephone Sales Desk: (023) 8049 4333 or:

Product Helpline (023) 8049 4344.

A proof of purchase must be provided.

If upon inspection it is found that the fault occurring is due to defective materials or workmanship, repairs will be carried out free of charge. This guarantee period covering parts/labour is 12 months from the date of purchase except where tools are hired out when the guarantee period is 90 days from the date of purchase. The guarantee is extended to 24 months for parts only. This guarantee does not apply to normal wear and tear, nor does it cover any damage caused by misuse, careless or unsafe handling, alterations, accidents, or repairs attempted or made by any personnel other than the authorised Draper warranty repair agent.

Note: If the tool is found not to be within the terms of warranty, repairs and carriage charges will be quoted and made accordingly.

This guarantee applies in lieu of any other guarantee expressed or implied and variations of its terms are not authorised.

Your Draper guarantee is not effective unless you can produce upon request a dated receipt or invoice to verify your proof of purchase within the guarantee period.

Please note that this guarantee is an additional benefit and does not affect your statutory rights.

Draper Tools Limited.

4. INTRODUCTION

4.1 SCOPE

Designed for use where constant level or repeat level measurements are required. Applications includes alignment of windows, dado rails, kitchen units, stairs and outdoor levelling etc.

4.2 SPECIFICATION

Stock No's	88640
Part No's.....	LLK3
Laser classification	Class II
Output power.....	<1mW
Wavelength.....	650nm
Laser accuracy.....	0.5mm/M
Operating range.....	3-8M†
Self-levelling range	± 6 °
Power source.....	3 x AA
Tripod:	
Minimum height	420mm
Maximum height	1180mm

†Dependent upon lighting conditions etc.

WARNING: LASER RADIATION, DO NOT STARE INTO BEAM. CLASS II LASER PRODUCT.

4.3 HANDLING AND STORAGE

Care must still be taken when handling and lifting. Dropping this laser level will have an effect on the accuracy and may also result in personal injury. This laser level is not a toy and must be respected.

The environment could have a negative result on its operation if you are not careful. If the air is damp, components will rust. If the laser level is unprotected from dust and debris; components will become clogged: And if not cleaned and maintained correctly or regularly, the laser level will not perform at its best.

5. GENERAL SAFETY INSTRUCTIONS

5.1 GENERAL SAFETY INSTRUCTIONS FOR LASER USE

Laser radiation. Do NOT stare into beam. Class II laser product.

Viewing the laser output with certain optical instruments (for example, eye loupes, magnifiers and microscopes) with a distance of 100mm may pose an eye hazard.

Viewing the laser output with optical instruments designed for use at a distance (for example, telescopes and binoculars) may pose an eye hazard.

Do NOT direct the beam towards a person's eye.

Avoid positioning the laser such that it may lead to unintentional eye exposure to any potential passing pedestrians/traffic.

Do NOT direct the beam towards animals.

Do NOT direct the beam towards aircraft or moving vehicles.

Do NOT use in the vicinity of children.

Do NOT direct the beam onto reflective surfaces.

Always switch off when not in use and do not leave unattended. Remove the batteries before storing the laser level away.

Store the level in a dry location, out of reach of children.

Care must be taken to ensure that the laser level is not dropped, knocked or damaged during use or storage.

This laser level product has no serviceable parts. Do not attempt to disassemble or repair.

6. TECHNICAL DESCRIPTION

6.1 IDENTIFICATION

- ① Laser beam aperture.
- ② ON/OFF switch (horizontal beam).
- ③ ON/OFF switch (vertical beam).
- ④ Power light (vertical beam).
- ⑤ Battery compartment.
- ⑥ Power light (horizontal beam).
- ⑦ Angle rotation indicator.
- ⑧ Horizontal vials (x2).
- ⑨ Tripod mount/base.
- ⑩ Horizontal adjustments wheels (x3).
- ⑪ Transportation lock.

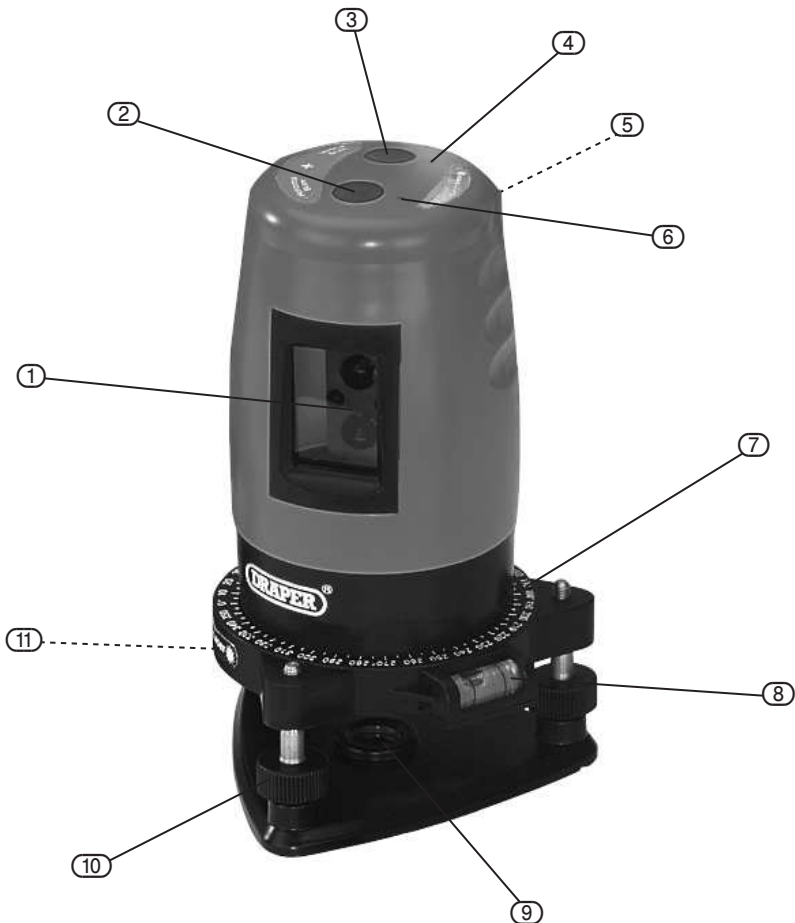

7. UNPACKING AND CHECKING

7.1 PACKAGING

Carefully remove the laser level from the packaging and examine it for any sign of damage that may have happened during shipping. Lay the contents out and check them against the parts shown below. If any part is damaged or missing; please contact the Draper Helpline (the telephone number appears on the Title page) and do not attempt to use the laser level.

The packaging material should be retained at least during the guarantee period: in case the laser level needs to be returned for repair.

Warning! Some of the packaging materials used may be harmful to children. Do not leave any of these materials in the reach of children.

If any of the packaging is to be thrown away, make sure they are disposed of correctly; according to local regulations.

7.2 WHAT'S IN THE BOX?

The packaging contains several additional parts and semi-assembled elements that require final assembly. Lay out the contents and check off the items against those featured below.

- ⑫ 1180mm tripod.
- ⑬ 3 x AA batteries.
- ⑭ Laser enhancing goggles.



7. ASSEMBLY

8.1 LASER LEVEL BATTERY INSTALLATION

Slide the battery compartment cover (5) up slightly before lowering it down to remove it. Insert the 3 x AA batteries, taking note of the polarity indicated inside the compartment. Replace the cover securely.

Note: Ensure the laser beam aperture is covered to avoid accidental beam exposure during battery installation/replacement.

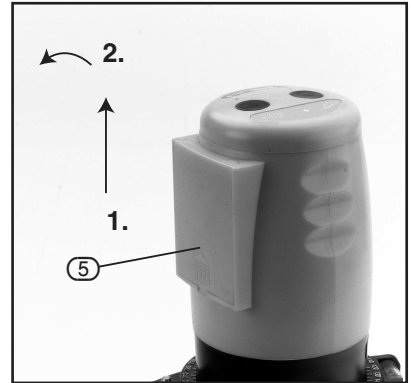

9. OPERATION AND USE

9.1 OPERATION AND USE

Remove the tripod from the case, extend all the legs and place the tripod into position. Ensure the locking screw on the side of the tripod is tight. Adjust the height of each leg individually to align the bubble on the top of the tripod as near as possible to the centre of the circle.

Remove the rotary base and screw onto the tripod taking care not to disturb its position. Using the three adjusters, align the bubble on the rotary base as near to the centre of the circle as possible then align the bubble on the self-levelling laser level as near to centre of both vials.

To fine tune the rotary base, place the level centrally into the clamp and tighten. Rotate the level clockwise until it is directly over one of the three adjusters. Turn the adjuster until the horizontal vial is level. Rotate the level a further 120° clockwise and adjust it to horizontal. Rotate the level a further 120° to complete the final adjustment.

Note: If the location of the height of the tripod is changed these adjustments must be repeated.

9.2 SELF-LEVELLING LASER LEVEL

Note: Loosen the transportation lock (11) prior to use. Select the vertical line with button (3) or the horizontal line with button (6) or both for a cross.

Note: Wearing the goggles supplied will enhance the laser beam. The beam will remain level providing the error margin does not exceed 6°(+/-).



10. EXPLANATION OF SYMBOLS

10.1 EXPLANATION OF SYMBOLS



Do not dispose of WEEE*
unsorted municipal waste.



LASER RADIATION.
DO NOT STARE INTO BEAM.

11. DISPOSAL

11.1 DISPOSAL

- At the end of the machine's working life, or when it can no longer be repaired, ensure that it is disposed of according to national regulations.
- Contact your local authority for details of collection schemes in your area.

In all circumstances:

- Do not dispose of power tools with domestic waste.
- Do not incinerate.
- Do not abandon in the environment.
- Do not dispose of WEEE* as unsorted municipal waste.



* Waste Electrical & Electronic Equipment.

CONTACTS

Draper Tools Limited, Hursley Road,
Chandler's Ford, Eastleigh, Hampshire. SO53 1YF. U.K.

Helpline: (023) 8049 4344

Sales Desk: (023) 8049 4333

Internet: drapertools.com

E-mail: sales@drapertools.com

General Enquiries: (023) 8026 6355

Service/Warranty Repair Agent:

For aftersales servicing or warranty repairs, please contact the Draper Tools Helpline for details of an agent in your local area.

YOUR DRAPER STOCKIST

SRKC0617

©Published by Draper Tools Limited.

No part of this publication may be reproduced, stored in a retrieval system or transmitted in any form or by any means, electronic, mechanical photocopying, recording or otherwise without prior permission in writing from Draper Tools Ltd.